

David A. Madsen | David P. Madsen

fifth  
edition

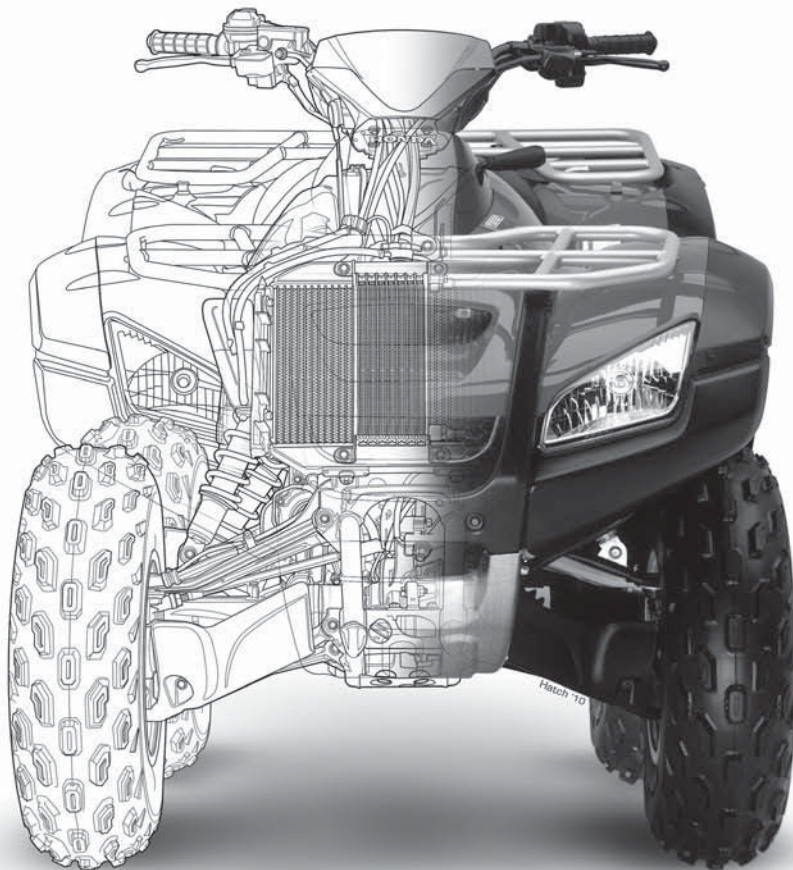
# Engineering Drawing & Design





fifth edition

# Engineering Drawing & Design



## David A. Madsen

President, Madsen Designs Inc., [www.madsendesigns.com](http://www.madsendesigns.com)  
 Faculty Emeritus, Former Department Chairperson, Drafting Technology, Autodesk Premier Training Center  
 Clackamas Community College, Oregon City, Oregon

**Autodesk**  
Authorized Author

Director Emeritus, American Design Drafting Association

## David P. Madsen

President, Engineering Drafting & Design, Inc.  
 Vice President, Madsen Designs Inc.  
 Computer-Aided Design and Drafting Consultant and Educator

**Autodesk**  
Authorized Author

SolidWorks Research Associate  
 American Design Drafting Association Member

**J. Lee Turpin** (author of Student CD Descriptive Geometry Reference Material)  
 Former Drafting Technology Instructor, Department Chair, Vocational Counselor  
 Clackamas Community College, Oregon City, Oregon  
 Former Drafting Technology Instructor, Chemeketa Community College, Salem, Oregon  
 Mount Hood Community College, Gresham, Oregon, Oregon Institute of Technology,  
 Oregon Polytechnic Institute, Portland Community College, Portland, Oregon

 **DELMAR**  
 CENGAGE Learning™

Australia • Brazil • Japan • Korea • Mexico • Singapore • Spain • United Kingdom • United States

Copyright 2011 Cengage Learning. All Rights Reserved. May not be copied, scanned, or duplicated, in whole or in part. Due to electronic rights, some third party content may be suppressed from the eBook and/or eChapter(s). Editorial review has deemed that any suppressed content does not materially affect the overall learning experience. Cengage Learning reserves the right to remove additional content at any time if subsequent rights restrictions require it.

This is an electronic version of the print textbook. Due to electronic rights restrictions, some third party content may be suppressed. Editorial review has deemed that any suppressed content does not materially affect the overall learning experience. The publisher reserves the right to remove content from this title at any time if subsequent rights restrictions require it. For valuable information on pricing, previous editions, changes to current editions, and alternate formats, please visit [www.cengage.com/highered](http://www.cengage.com/highered) to search by ISBN#, author, title, or keyword for materials in your areas of interest.

**Engineering Drawing and Design,  
Fifth Edition**

David A. Madsen, David P. Madsen

Vice President, Editorial: Dave Garza

Director of Learning Solutions: Sandy Clark

Senior Acquisitions Editor: James Devoe

Managing Editor: Larry Main

Senior Product Manager: Sharon Chambliss

Editorial Assistant: Christopher Savino

Vice President, Marketing: Jennifer Baker

Executive Marketing Manager:

Deborah S. Yarnell

Marketing Manager: Kathryn Hall

Production Director: Wendy Troeger

Production Manager: Mark Bernard

Senior Content Project Manager:

Michael Tubbert

Senior Art Director: Casey Kirchmayer

Technology Project Manager:

Christopher Catalina

Production Technology Analyst: Joe Pliss

Cover Illustration: ATV Illustration © Jim  
Hatch, [www.hatchillustration.com](http://www.hatchillustration.com), Client:

Honda, Ad Agency: Vreeke and Associates.

© 2012 Delmar, Cengage Learning

ALL RIGHTS RESERVED. No part of this work covered by the copyright herein may be reproduced, transmitted, stored, or used in any form or by any means graphic, electronic, or mechanical, including but not limited to photocopying, recording, scanning, digitizing, taping, Web distribution, information networks, or information storage and retrieval systems, except as permitted under Section 107 or 108 of the 1976 United States Copyright Act, without the prior written permission of the publisher.

For product information and technology assistance, contact us at  
**Cengage Learning Customer & Sales Support, 1-800-354-9706**

For permission to use material from this text or product,  
submit all requests online at [www.cengage.com/permissions](http://www.cengage.com/permissions).

Further permissions questions can be e-mailed to  
[permissionrequest@cengage.com](mailto:permissionrequest@cengage.com)

Library of Congress Control Number: 2010940076

ISBN-13: 978-1-111-30957-2

ISBN-10: 1-111-30957-4

**Delmar**

5 Maxwell Drive

Clifton Park, NY 12065-2919

USA

Cengage Learning is a leading provider of customized learning solutions with office locations around the globe, including Singapore, the United Kingdom, Australia, Mexico, Brazil, and Japan. Locate your local office at:

**[international.cengage.com/region](http://international.cengage.com/region)**

Cengage Learning products are represented in Canada by Nelson Education, Ltd.

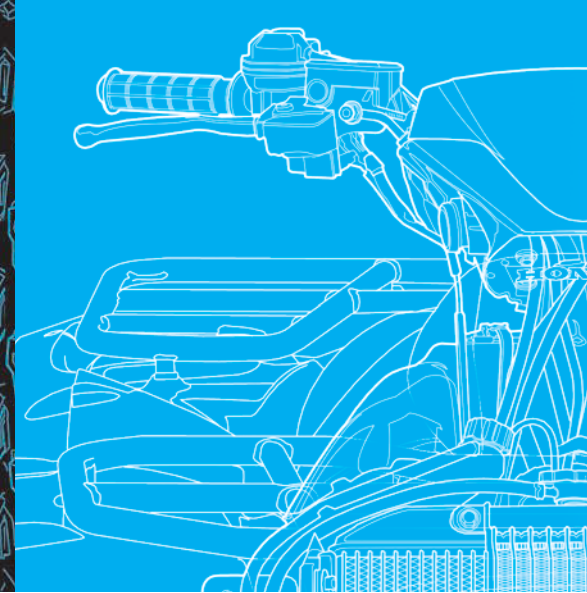
To learn more about Delmar, visit [www.cengage.com/delmar](http://www.cengage.com/delmar)

Purchase any of our products at your local college store or at our preferred online store [www.cengagebrain.com](http://www.cengagebrain.com)

**Notice to the Reader**

Publisher does not warrant or guarantee any of the products described herein or perform any independent analysis in connection with any of the product information contained herein. Publisher does not assume, and expressly disclaims, any obligation to obtain and include information other than that provided to it by the manufacturer. The reader is expressly warned to consider and adopt all safety precautions that might be indicated by the activities described herein and to avoid all potential hazards. By following the instructions contained herein, the reader willingly assumes all risks in connection with such instructions. The publisher makes no representations or warranties of any kind, including but not limited to, the warranties of fitness for particular purpose or merchantability, nor are any such representations implied with respect to the material set forth herein, and the publisher takes no responsibility with respect to such material. The publisher shall not be liable for any special, consequential, or exemplary damages resulting, in whole or part, from the readers' use of, or reliance upon, this material.

# CONTENTS



Preface . . . . . xii  
Acknowledgments . . . . . xxiv

## SECTION 1

### INTRODUCTION TO ENGINEERING DRAWING AND DESIGN 1

#### Chapter 1—Introduction to Engineering Drawing and Design 2

Learning Objectives . . . . . 2  
**The Engineering Design Application . . . . . 2**  
Introduction . . . . . 8  
A History of Engineering Drawing . . . . . 10  
The Drafter . . . . . 14  
Drafting Fields . . . . . 14  
Education and Qualifications . . . . . 22  
Drafting Job Opportunities . . . . . 25  
Searching for a Drafting Position . . . . . 26  
Drafting Salaries and Working Conditions . . . . . 27  
Professional Organization . . . . . 28  
Drafting Standards . . . . . 29  
Workplace Ethics . . . . . 30  
Copyrights . . . . . 31  
Trademarks . . . . . 32  
**CADD Applications . . . . . 33**  
**Professional Perspective . . . . . 34**  
Web Site Research . . . . . 37  
Introduction to Engineering Drawing  
and Design Test . . . . . 38  
Introduction to Engineering Drawing  
and Design Problems . . . . . 38

#### Chapter 2—Drafting Equipment, Media, and Reproduction Methods 39

Learning Objectives . . . . . 39  
**The Engineering Design Application . . . . . 39**

Introduction . . . . . 40  
Manual Drafting Equipment and Supplies . . . . . 41  
Drafting Furniture . . . . . 41  
Drafting Pencils and Leads . . . . . 41  
Technical Pens, Pen Cleaning, and Ink . . . . . 42  
Erasers and Erasing . . . . . 42  
Dividers . . . . . 43  
Parallel Bar . . . . . 43  
Triangles . . . . . 43  
Templates . . . . . 44  
Irregular Curves . . . . . 45  
Drafting Machines . . . . . 45  
Scales . . . . . 46  
Drafting Media . . . . . 50  
Sheet Size and Format . . . . . 53  
Diazo Reproduction . . . . . 62  
Photocopy Reproduction . . . . . 62  
Properly Folding Prints . . . . . 62  
Microfilm . . . . . 62  
**CADD Applications . . . . . 64**  
**Professional Perspective . . . . . 64**  
**Math Applications . . . . . 65**  
Web Site Research . . . . . 65  
Drafting Equipment, Media, and Reproduction  
Methods Test . . . . . 65  
Drafting Equipment, Media, and Reproduction  
Methods Problems . . . . . 66

#### Chapter 3—Computer-Aided Design and Drafting (CADD) 69

Learning Objectives . . . . . 69  
**The Engineering Design Application . . . . . 69**  
Introduction to Computer-Aided Design  
and Drafting (CADD) . . . . . 70  
The CADD Workstation . . . . . 71  
CADD Software Products . . . . . 71  
CADD Formats . . . . . 75  
Industry and CADD . . . . . 79  
**CADD Applications 3-D . . . . . 89**

Virtual Reality . . . . .	89
Basic CADD Techniques . . . . .	93
Surface Modeling Techniques . . . . .	102
Solid Modeling Techniques . . . . .	104
<b>CADD Applications 3-D . . . . .</b>	<b>110</b>
CADD Standards . . . . .	111
Productivity with CADD . . . . .	112
<b>Green Technology Application . . . . .</b>	<b>115</b>
<b>Professional Perspective . . . . .</b>	<b>118</b>
Web Site Research . . . . .	118
Computer-Aided Design and Drafting (CADD) Test . . . . .	119
Computer-Aided Design and Drafting (CADD) Problems . . . . .	119

## Chapter 4—Manufacturing Materials and Processes 121

Learning Objectives . . . . .	121
<b>The Engineering Design Application . . . . .</b>	<b>121</b>
Introduction . . . . .	122
Manufacturing Materials . . . . .	122
<b>Green Technology Application . . . . .</b>	<b>126</b>
Metallurgy . . . . .	126
Plastics and Polymers . . . . .	126
Plastic Resin Identification Codes . . . . .	129
Plastics Material Selection Applications . . . . .	129
<b>Green Technology Application . . . . .</b>	<b>130</b>
Material Selection . . . . .	131
<b>CADD Applications 3-D . . . . .</b>	<b>133</b>
Manufacturing Processes . . . . .	135
Machine Processes . . . . .	140
<b>CADD Applications . . . . .</b>	<b>146</b>
Machined Feature and Drawing Representations . . . . .	147
Manufacturing Plastic Products . . . . .	153
Thermoset Plastic Fabrication Process . . . . .	157
Manufacturing Composites . . . . .	158
Rapid Prototyping (RP) . . . . .	160
Tool Design . . . . .	160
Computer-Integrated Manufacturing (CIM) . . . . .	161
Application Examples . . . . .	162
Integration of Computer-Aided Design and Computer-Aided Manufacturing (CAD/CAM) . . . . .	164
Statistical Process Control (SPC) . . . . .	165
<b>CADD Applications 3-D . . . . .</b>	<b>166</b>
<b>Green Technology Application . . . . .</b>	<b>168</b>
<b>Professional Perspective . . . . .</b>	<b>168</b>
<b>Math Application . . . . .</b>	<b>169</b>
Web Site Research . . . . .	169
Manufacturing Materials and Processes Test . . . . .	170
Manufacturing Materials and Processes Problems . . . . .	170

## SECTION 2 FUNDAMENTAL APPLICATIONS 173

### Chapter 5—Sketching Applications 174

Learning Objectives . . . . .	174
<b>The Engineering Design Application . . . . .</b>	<b>174</b>
Sketching . . . . .	174
Sketching Tools and Materials . . . . .	175
Sketching Straight Lines . . . . .	175
Sketching Circular Lines . . . . .	176
Sketching Arcs . . . . .	179
Sketching Ellipses . . . . .	180
Measurement Lines and Proportions . . . . .	180
Introduction to the Block Technique . . . . .	181
Creating Multiview Sketches . . . . .	183
Creating Isometric Sketches . . . . .	184
<b>CADD Applications 3-D . . . . .</b>	<b>187</b>
<b>Professional Perspective . . . . .</b>	<b>191</b>
Sketching Applications Test . . . . .	191
Sketching Applications Problems . . . . .	192

### Chapter 6 —Lines and Lettering 193

Learning Objectives . . . . .	193
<b>The Engineering Design Application . . . . .</b>	<b>193</b>
Lines . . . . .	193
Types of Lines . . . . .	194
<b>CADD Applications . . . . .</b>	<b>204</b>
Lettering . . . . .	207
Lettering on Engineering Drawings . . . . .	207
Lettering Numbers . . . . .	207
Other Lettering Styles . . . . .	208
Lettering Legibility . . . . .	209
<b>CADD Applications . . . . .</b>	<b>210</b>
<b>CADD Applications 3-D . . . . .</b>	<b>212</b>
<b>Professional Perspective . . . . .</b>	<b>212</b>
<b>Math Applications . . . . .</b>	<b>214</b>
Web Site Research . . . . .	214
Lines and Lettering Test . . . . .	214
Lines and Lettering Problems . . . . .	214

### Chapter 7—Drafting Geometry 218

Learning Objectives . . . . .	218
<b>The Engineering Design Application . . . . .</b>	<b>218</b>
<b>CADD Applications . . . . .</b>	<b>219</b>
Drafting Geometry . . . . .	219
Characteristics of Lines . . . . .	219
Geometric Shapes . . . . .	220
Common Geometric Constructions . . . . .	224
Constructing Polygons . . . . .	230
Constructing Tangencies . . . . .	233

Constructing an Ellipse . . . . .	236
<b>Professional Perspective</b> . . . . .	<b>237</b>
<b>Math Applications</b> . . . . .	<b>238</b>
Web Site Research . . . . .	238
Drafting Geometry Test . . . . .	238
Drafting Geometry Problems . . . . .	239

## SECTION 3

### **DRAFTING VIEWS AND ANNOTATIONS 247**

#### **Chapter 8—Multiviews 248**

Learning Objectives . . . . .	248
<b>The Engineering Design Application</b> . . . . .	<b>248</b>
Multiviews . . . . .	250
Third-Angle Projection . . . . .	252
First-Angle Projection . . . . .	254
View Selection . . . . .	254
Projection of Contours, Circles, and Arcs . . . . .	262
Line Precedence . . . . .	266
Multiview Analysis and Review . . . . .	266
Recommended Review . . . . .	267
Multiview Layout . . . . .	267
<b>CADD Applications 2-D</b> . . . . .	<b>267</b>
<b>CADD Applications 3-D</b> . . . . .	<b>270</b>
<b>CADD Applications</b> . . . . .	<b>275</b>
<b>Professional Perspective</b> . . . . .	<b>275</b>
<b>Math Applications</b> . . . . .	<b>277</b>
Web Site Research . . . . .	277
Multiviews Test . . . . .	277
Multiviews Problems . . . . .	277

#### **Chapter 9—Auxiliary Views 292**

Learning Objectives . . . . .	292
<b>The Engineering Design Application</b> . . . . .	<b>292</b>
Auxiliary Views . . . . .	292
Auxiliary View Visualization . . . . .	295
Drawing Curves in Auxiliary Views . . . . .	297
View Enlargements . . . . .	297
Drawing a Removed Auxiliary View . . . . .	297
Locating Views on Different Sheets . . . . .	298
Drawing a Rotated Auxiliary View . . . . .	298
Secondary Auxiliary Views . . . . .	299
Auxiliary View Analysis and Review . . . . .	300
Descriptive Geometry . . . . .	302
Auxiliary View Layout . . . . .	302
<b>CADD Applications</b> . . . . .	<b>304</b>
<b>CADD Applications 2-D</b> . . . . .	<b>305</b>
<b>CADD Applications 3-D</b> . . . . .	<b>306</b>
<b>Professional Perspective</b> . . . . .	<b>307</b>
<b>Math Applications</b> . . . . .	<b>307</b>

Web Site Research . . . . .	307
Auxiliary Views Test . . . . .	308
Auxiliary Views Problems . . . . .	308

#### **Chapter 10—Dimensioning and Tolerancing 315**

Learning Objectives . . . . .	315
<b>The Engineering Design Application</b> . . . . .	<b>315</b>
Introduction to Dimensioning . . . . .	319
Dimensioning Basics . . . . .	320
Dimensioning Characteristics and Definitions . . . . .	320
Fundamental Dimensioning Rules . . . . .	323
Dimensioning Components . . . . .	324
Dimensioning Symbols . . . . .	325
Dimensioning Systems . . . . .	326
Dimensioning Fundamentals . . . . .	327
Preferred Dimensioning Practices . . . . .	334
Notes for Machined Features . . . . .	338
Placing Location Dimensions . . . . .	342
Specifying Dimension Origin . . . . .	344
Dimensioning Auxiliary Views . . . . .	344
<b>CADD Applications 2-D</b> . . . . .	<b>345</b>
Using General Notes . . . . .	349
Tolerancing Applications . . . . .	351
<b>CADD Applications 3-D</b> . . . . .	<b>360</b>
Dimensions Applied to Platings and Coatings . . . . .	361
Maximum and Minimum Dimensions . . . . .	361
Casting Drawing and Design . . . . .	361
Machining Allowance . . . . .	362
Casting Drawings . . . . .	363
Forging, Design, and Drawing . . . . .	363
Drawings for Plastic Part Manufacturing . . . . .	369
Machined Surfaces . . . . .	370
Design and Drafting of Machined Features . . . . .	373
Tool Design . . . . .	373
<b>CADD Applications</b> . . . . .	<b>378</b>
Introduction to ISO 9000 . . . . .	378
<b>Professional Perspective</b> . . . . .	<b>379</b>
<b>CADD Applications</b> . . . . .	<b>381</b>
Recommended Review . . . . .	382
<b>Math Applications</b> . . . . .	<b>383</b>
Web Site Research . . . . .	383
Dimensioning and Tolerancing Test . . . . .	384
Dimensioning and Tolerancing Problems . . . . .	384

#### **Chapter 11—Fasteners and Springs 392**

Learning Objectives . . . . .	392
<b>The Engineering Design Application</b> . . . . .	<b>392</b>
Screw Thread Fasteners . . . . .	393
Thread-Cutting Tools . . . . .	395
Thread Forms . . . . .	395
Thread Representations . . . . .	397



Drawing Thread Representations . . . . .	398
Drawing Detailed Threads . . . . .	400
Thread Notes . . . . .	403
Measuring Screw Threads . . . . .	406
<b>CADD Applications 2-D . . . . .</b>	<b>406</b>
<b>CADD Applications 3-D . . . . .</b>	<b>407</b>
Threaded Fasteners . . . . .	408
Thread Design Guidelines . . . . .	410
Lag Screws and Wood Screws . . . . .	414
Self-Tapping Screws . . . . .	414
Thread Inserts . . . . .	415
Self-Clinching Fasteners . . . . .	415
How to Draw Various Types of Screw Heads . . . . .	416
Drawing Nuts . . . . .	417
Drawing Washers . . . . .	418
Drawing Dowel Pins . . . . .	418
Taper Pins and Other Pins . . . . .	418
Retaining Rings . . . . .	419
Keys, Keyways, and Keyseats . . . . .	419
Rivets . . . . .	420
Designing and Drawing Springs . . . . .	421
<b>CADD Applications . . . . .</b>	<b>421</b>
Spring Representations and Specifications . . . . .	426
Recommended Review . . . . .	428
<b>CADD Applications 2-D . . . . .</b>	<b>428</b>
<b>CADD Applications 3-D . . . . .</b>	<b>429</b>
<b>Professional Perspective . . . . .</b>	<b>429</b>
<b>Math Applications . . . . .</b>	<b>431</b>
Web Site Research . . . . .	431
Fasteners and Springs Test . . . . .	432
Fasteners and Springs Problems . . . . .	432

## Chapter 12—Sections, Revolutions, and Conventional Breaks 439

Learning Objectives . . . . .	439
<b>The Engineering Design Application . . . . .</b>	<b>439</b>
Introduction to Sectional Views . . . . .	440
Cutting-Plane Lines and Sectional View Identification . . . . .	440
Section Lines . . . . .	442
Full Sections . . . . .	444
Half Sections . . . . .	444
Offset Sections . . . . .	445
Aligned Sections . . . . .	446
Unsectioned Features . . . . .	446
Intersections in Section . . . . .	447
Conventional Revolutions . . . . .	447
Broken-Out Sections . . . . .	448
Auxiliary Sections . . . . .	448
<b>CADD Applications 2-D . . . . .</b>	<b>449</b>
<b>CADD Applications 3-D . . . . .</b>	<b>450</b>
Conventional Breaks . . . . .	452
<b>CADD Applications . . . . .</b>	<b>453</b>

Revolved Sections . . . . .	453
Removed Sections . . . . .	454
Locating Sectional Views on Different Sheets . . . . .	455
Recommended Review . . . . .	457
<b>Professional Perspective . . . . .</b>	<b>457</b>
<b>Math Applications . . . . .</b>	<b>459</b>
Web Site Research . . . . .	459
Sections, Revolutions, and Conventional Breaks Test . . . . .	459
Sections, Revolutions, and Conventional Breaks Problems . . . . .	460

## Chapter 13—Geometric Dimensioning and Tolerancing 475

Learning Objectives . . . . .	475
<b>The Engineering Design Application . . . . .</b>	<b>475</b>
Introduction . . . . .	476
GD&T Symbols . . . . .	477
Datums . . . . .	477
Applying Material Condition and Material Boundary Symbols . . . . .	492
Limits of Size Application . . . . .	494
Perfect Form Boundary . . . . .	494
Applying Regardless of Feature Size and Regardless of Material Boundary . . . . .	494
Applying Maximum Material Condition . . . . .	496
Applying Least Material Condition . . . . .	498
Application of RMB on a Primary Datum Feature . . . . .	499
Application of RMB on a Secondary and Tertiary Datum Feature . . . . .	499
The Effect of Datum Precedence and Material Condition . . . . .	499
Introduction to Geometric Characteristic and Related Symbols . . . . .	501
Form Geometric Tolerances . . . . .	504
Orientation Geometric Tolerances . . . . .	507
Applying Profile Geometric Tolerances . . . . .	532
Runout Geometric Tolerance . . . . .	544
Specifying Independency . . . . .	546
<b>CADD Applications . . . . .</b>	<b>547</b>
<b>CADD Applications 2-D . . . . .</b>	<b>548</b>
<b>Professional Perspective . . . . .</b>	<b>553</b>
<b>Math Applications . . . . .</b>	<b>555</b>
Web Site Research . . . . .	555
Geometric Dimensioning and Tolerancing Test . . . . .	556
Geometric Dimensioning and Tolerancing Problems . . . . .	556

## Chapter 14—Pictorial Drawings and Technical Illustrations 562

Learning Objectives . . . . .	562
<b>The Engineering Design Application . . . . .</b>	<b>562</b>

Introduction to Pictorial Drawing and  
 Technical Illustration Pictorial Drawings . . . . . 563  
 Pictorial Drawings . . . . . 563  
 Isometric Projections and Drawings . . . . . 566  
 Types of Isometric Drawings . . . . . 568  
 Isometric Construction Techniques . . . . . 568  
 Dimetric Pictorial Representation . . . . . 574  
 Trimetric Pictorial Representation . . . . . 574  
 Exploded Pictorial Drawing . . . . . 575  
 Oblique Drawing . . . . . 576  
 Perspective Drawing . . . . . 578  
 Drawing a One-Point Perspective . . . . . 578  
 Drawing a Two-Point Perspective . . . . . 580  
 Drawing a Three-Point Perspective . . . . . 580  
 Drawing Circles and Curves in Perspective . . . . . 582  
 Using Basic Shading Techniques . . . . . 583  
 Pictorial Drawing Layout Techniques . . . . . 584  
**CADD Applications 3-D . . . . . 585**  
**Professional Perspective . . . . . 589**  
**Math Applications . . . . . 590**  
 Web Site Research . . . . . 590  
 Pictorial Drawings and Technical  
 Illustrations Test . . . . . 590  
 Pictorial Drawings and Technical Illustrations  
 Problems . . . . . 591

**SECTION 4**  
**WORKING DRAWINGS 595**

**Chapter 15—Working Drawings 596**

Learning Objectives . . . . . 596  
**The Engineering Design Application . . . . . 596**  
 Introduction to Section Four . . . . . 597  
 Introduction to Working Drawings . . . . . 597  
 Detail Drawings . . . . . 598  
**CADD Applications 2-D . . . . . 601**  
**CADD Applications 3-D . . . . . 601**  
 Assembly Drawings . . . . . 603  
 Types of Assembly Drawings . . . . . 604  
 Identification Numbers . . . . . 607  
 Parts Lists . . . . . 608  
 Purchase Parts . . . . . 612  
 Engineering Changes . . . . . 614  
**CADD Applications 2-D . . . . . 614**  
**CADD Applications 3-D . . . . . 615**  
 Drawing From a Prototype . . . . . 620  
 Analysis of a Set of Working Drawings . . . . . 620  
**CADD Applications 3-D . . . . . 627**  
**Professional Perspective . . . . . 628**  
**Math Application . . . . . 629**  
 Web Site Research . . . . . 629  
 Working Drawings Test . . . . . 629  
 Working Drawings Problems . . . . . 630

**Chapter 16—Mechanisms: Linkages,  
 Cams, Gears, and  
 Bearings 678**

Learning Objectives . . . . . 678  
**The Engineering Design Application . . . . . 678**  
 Mechanism . . . . . 679  
 Linkages . . . . . 679  
 Linkage Symbols . . . . . 679  
 Types of Linkages . . . . . 680  
 Cam Design . . . . . 682  
**CADD Applications . . . . . 683**  
 Cam Displacement Diagrams . . . . . 684  
 Construction of an Inline Follower Plate  
 Cam Profile . . . . . 687  
 Preparing the Formal Plate Cam Drawing . . . . . 688  
 Construction of an Offset Follower Plate  
 Cam Profile . . . . . 688  
 Drum Cam Drawing . . . . . 690  
**CADD Applications . . . . . 691**  
 Introduction to Gears . . . . . 691  
 Gear Structure . . . . . 692  
 Splines . . . . . 692  
 Gear Types . . . . . 693  
 Spur Gear Design . . . . . 696  
 Drawing Specifications and Tolerances . . . . . 696  
 Designing and Drawing Spur Gears . . . . . 696  
 Designing Spur Gear Trains . . . . . 702  
 Designing and Drawing the Rack  
 and Pinion . . . . . 703  
 Designing and Drawing Bevel Gears . . . . . 703  
 Designing and Drawing Worm Gears . . . . . 705  
 Plastic Gears . . . . . 706  
**CADD Applications . . . . . 708**  
 Bearings . . . . . 709  
 Drawing Bearing Symbols . . . . . 710  
 Bearing Codes . . . . . 710  
 Bearing Selection . . . . . 710  
 Gear and Bearing Assemblies . . . . . 715  
**Professional Perspective . . . . . 717**  
**Math Application . . . . . 718**  
 Web Site Research . . . . . 718  
 Mechanisms: Linkages, Cams, Gears, and  
 Bearings Test . . . . . 718  
 Mechanisms: Linkages, Cams, Gears, and  
 Bearings Problems . . . . . 719

**Chapter 17—Belt and Chain Drives 727**

Learning Objectives . . . . . 727  
**The Engineering Design Application . . . . . 727**  
 Introduction . . . . . 728  
 Advantages of Gear Drives . . . . . 728  
 Advantages of Belt Drives . . . . . 728  
 Advantages of Chain Drives . . . . . 728  
 Belts and Belt Drives . . . . . 728

Belt Types . . . . .	728
Typical Belt Drive Design . . . . .	730
Belt Drive Selection . . . . .	730
Chain Drives . . . . .	734
Chain Drive Sprockets . . . . .	734
Chain Classification and Types . . . . .	734
Precision Chains . . . . .	734
<b>CADD Applications . . . . .</b>	<b>735</b>
Nonprecision Chains . . . . .	736
Light-Duty Chain . . . . .	736
Chain Drive Design . . . . .	737
Roller Chain Drive Selection . . . . .	737
<b>Professional Perspective . . . . .</b>	<b>741</b>
<b>Math Applications . . . . .</b>	<b>741</b>
Web Site Research . . . . .	742
Belt and Chain Drives Test . . . . .	742
Belt and Chain Drives Problems . . . . .	742

## Chapter 18—Welding Processes and Representations 745

Learning Objectives . . . . .	745
<b>The Engineering Design Application . . . . .</b>	<b>745</b>
Welding Processes . . . . .	746
Elements of Welding Drawings . . . . .	748
Types of Welds . . . . .	751
Weld Symbol Leader Arrow Related to Weld Location . . . . .	755
Additional Weld Characteristics . . . . .	759
Welding Tests . . . . .	762
Welding Specifications . . . . .	765
Prequalified Welded Joints . . . . .	765
Weld Design . . . . .	765
<b>CADD Applications 2-D . . . . .</b>	<b>766</b>
<b>Professional Perspective . . . . .</b>	<b>768</b>
<b>Math Application . . . . .</b>	<b>768</b>
Web Site Research . . . . .	769
Welding Processes and Representations Test . . . . .	769
Welding Processes and Representations Problems . . . . .	769

## SECTION 5

## SPECIALTY DRAFTING AND DESIGN 775

### Chapter 19—Precision Sheet Metal Drafting 776

Learning Objectives . . . . .	776
<b>The Engineering Design Application . . . . .</b>	<b>776</b>
Introduction to Precision Sheet Metal Drafting . . . . .	776
Precision Sheet Metal Layout Options . . . . .	777
Precision Sheet Metal Material Bending . . . . .	782

<b>CADD Applications 2-D . . . . .</b>	<b>783</b>
Flanges . . . . .	787
Seams and Hems . . . . .	788
Roll Forming . . . . .	788
<b>CADD Applications 3-D . . . . .</b>	<b>789</b>
Material Applications in Sheet Metal Drafting . . . . .	791
Precision Sheet Metal Dimensioning Applications . . . . .	792
Sheet Metal Punch Applications . . . . .	796
<b>Professional Perspective . . . . .</b>	<b>798</b>
<b>Math Applications . . . . .</b>	<b>798</b>
Web Site Research . . . . .	798
Precision Sheet Metal Drafting Test . . . . .	799
Precision Sheet Metal Drafting Problems . . . . .	799

## Chapter 20—Electrical and Electronic Drafting 809

Learning Objectives . . . . .	809
<b>The Engineering Design Application . . . . .</b>	<b>809</b>
Introduction to Electrical and Electronic Drafting . . . . .	810
Fundamentals of Electrical Diagrams . . . . .	811
Generation, Transmission, and Distribution of Electricity . . . . .	814
Electric Power Substation Design Drawings . . . . .	814
Residential and Commercial Electrical Plans . . . . .	819
<b>Green Technology Application . . . . .</b>	<b>825</b>
<b>Professional Perspective . . . . .</b>	<b>827</b>
Electronic Drafting . . . . .	827
Electronic Diagrams . . . . .	827
Printed Circuit Technology . . . . .	838
Pictorial Drawings . . . . .	846
<b>CADD Applications . . . . .</b>	<b>848</b>
<b>Professional Perspective . . . . .</b>	<b>850</b>
<b>Math Applications . . . . .</b>	<b>851</b>
Web Site Research . . . . .	851
Electrical and Electronic Drafting Test . . . . .	852
Electrical and Electronic Drafting Problems . . . . .	852

## Chapter 21—Industrial Process Piping 868

Learning Objectives . . . . .	868
<b>The Engineering Design Application . . . . .</b>	<b>868</b>
Introduction . . . . .	869
Where Industrial Piping Is Used . . . . .	869
Pipe Drafting . . . . .	870
Pipe Drawings . . . . .	872
Types of Pipe . . . . .	876
Pipe Sizes and Wall Thickness . . . . .	878
Pipe Connection Methods . . . . .	879
Pipe Fittings . . . . .	881
Flanges . . . . .	885
Valves . . . . .	887
Pipe Drafting . . . . .	891
<b>CADD Applications 2-D . . . . .</b>	<b>901</b>

Piping Details . . . . . 910  
 Drawing Sheets . . . . . 910  
 Drawing Revisions . . . . . 914  
**CADD Applications 3-D . . . . . 914**  
**CADD Applications 2-D . . . . . 916**  
 Pipe Drafting Layout Techniques . . . . . 916  
**CADD Applications . . . . . 917**  
**Professional Perspective . . . . . 919**  
**Math Applications . . . . . 919**  
 Web Site Research . . . . . 920  
 Industrial Process Piping Test . . . . . 920  
 Industrial Process Piping Problems . . . . . 920

**Chapter 22—Structural Drafting 928**

Learning Objectives . . . . . 928  
**The Engineering Design Application . . . . . 928**  
 Introduction . . . . . 929  
 Structural Engineering . . . . . 930  
 Line Work on Structural Drawings . . . . . 930  
 Lettering on Structural Drawings . . . . . 933  
 Coordination of Working Drawings . . . . . 933  
 Structural Drafting Related to Construction  
     Systems . . . . . 936  
 Concrete Construction . . . . . 936  
 Concrete Block Construction . . . . . 945  
 Wood Construction . . . . . 947  
 Steel Construction . . . . . 960  
 Common Connection Methods . . . . . 966  
**Green Technology Application . . . . . 969**  
 Components in a Set of Structural Drawings . . . . . 972  
 Drawing Revisions . . . . . 979  
**CADD Applications . . . . . 983**  
**CADD Applications 3-D . . . . . 983**  
 General Construction Specifications . . . . . 986  
 Specifications for Commercial Construction . . . . . 986  
**Green Technology Application . . . . . 988**  
 Basic Drawing Layout Steps . . . . . 988  
 Pictorial Drawings . . . . . 991  
**Green Technology Application . . . . . 992**  
**CADD Applications . . . . . 997**  
**Professional Perspective . . . . . 998**  
**Math Applications . . . . . 998**  
 Web Site Research . . . . . 999  
 Structural Drafting Test . . . . . 1000  
 Structural Drafting Problems . . . . . 1000

**Chapter 23—Heating, Ventilating, and  
 Air-Conditioning (HVAC),  
 and Pattern Development 1015**

Learning Objectives . . . . . 1015  
**The Engineering Design Application . . . . . 1015**  
 Introduction . . . . . 1016

Introduction to HVAC Systems . . . . . 1016  
 HVAC Systems and Components . . . . . 1016  
**Green Technology Application . . . . . 1021**  
 HVAC Symbols . . . . . 1022  
 HVAC Drawings . . . . . 1022  
 Drawing Revisions . . . . . 1038  
 Duct Sizing . . . . . 1039  
**CADD Applications . . . . . 1041**  
**CADD Applications 2-D . . . . . 1041**  
**CADD Applications 3-D . . . . . 1044**  
 Sheet Metal Design and Drafting . . . . . 1045  
 Pattern Development . . . . . 1045  
 Establishing Intersections . . . . . 1055  
**CADD Applications 2-D . . . . . 1061**  
**CADD Applications . . . . . 1063**  
**Professional Perspective . . . . . 1064**  
**Math Applications . . . . . 1064**  
 Web Site Research . . . . . 1065  
 Heating, Ventilating, and Air-Conditioning  
     (HVAC), and Pattern Development Test . . . . . 1065  
 Heating, Ventilating, and Air-Conditioning  
     (HVAC), and Pattern Development  
     Problems . . . . . 1066

**Chapter 24—Civil Drafting 1072**

Learning Objectives . . . . . 1072  
**The Engineering Design Application . . . . . 1072**  
 Introduction to Survey: Direction . . . . . 1073  
 Surveying . . . . . 1075  
 Plotting Traverses . . . . . 1077  
 Distance and Elevation . . . . . 1078  
 Property Descriptions in Civil  
     Engineering . . . . . 1082  
 Beginning a Civil Engineering Drafting Project . . . . . 1084  
 Introduction to Site Plans . . . . . 1092  
 Introduction to Grading Plans . . . . . 1095  
 Subdivision Plans . . . . . 1095  
 Metrics in Site Planning . . . . . 1100  
 Introduction to Site Plan Layout . . . . . 1100  
 Site Design Considerations . . . . . 1101  
 Laying Out Property Lines . . . . . 1103  
**CADD Applications 2-D . . . . . 1106**  
 Drawing Contour Lines . . . . . 1107  
 Drawing Site Profiles . . . . . 1109  
 Drawing the Grading Plan . . . . . 1110  
**CADD Applications 2-D . . . . . 1113**  
**CADD Applications 3-D . . . . . 1115**  
**CADD Applications . . . . . 1116**  
**Green Technology Application . . . . . 1117**  
**Professional Perspective . . . . . 1119**  
**Math Applications . . . . . 1120**  
 Web Site Research . . . . . 1120  
 Civil Drafting Test . . . . . 1121  
 Civil Drafting Problems . . . . . 1121

## SECTION 6 ENGINEERING DESIGN 1129

### Chapter 25—The Engineering Design Process 1130

Learning Objectives . . . . .	1130
<b>The Engineering Design Application . . . . .</b>	<b>1130</b>
Introduction . . . . .	1131
Engineering Design and Industry Management Models . . . . .	1131
An Engineering Design Process . . . . .	1134
The Phase Gate Design Process . . . . .	1137
After Full Production . . . . .	1147
Creativity and Innovation in Design . . . . .	1147
Change and the Impact on the Design Process . . . . .	1149
Design Deliverables . . . . .	1150
The Design Process Responds to Changes in Engineering . . . . .	1150
<b>Green Technology Application . . . . .</b>	<b>1151</b>
<b>Professional Perspective . . . . .</b>	<b>1151</b>
Web Site Research . . . . .	1153
The Engineering Design Process Test . . . . .	1153
The Engineering Design Process Problems . . . . .	1153

## SECTION 7 ENGINEERING DRAWING AND DESIGN STUDENT CD 1157

Descriptive Geometry I . . . . .	1158
Descriptive Geometry II . . . . .	1158
Engineering Charts and Graphs . . . . .	1158
Engineering Drawing and Design Math Applications . . . . .	1158
Fluid Power . . . . .	1158

## APPENDICES

<b>Appendix A—Abbreviations . . . . .</b>	<b>1163</b>
<b>Appendix B—Conversion Charts:</b>	
Table 1—Inches to Millimeters . . . . .	1166
Table 2—Millimeters to Inches . . . . .	1166
Table 3—Inch/Metric Equivalents . . . . .	1166
Table 4—Inch/Metric—Conversion—Length, Area, Capacity, Weight . . . . .	1167
<b>Appendix C—Mathematical Rules Related to the Circle . . . . .</b>	<b>1168</b>
<b>Appendix D—General Applications of SAE Steels . . . . .</b>	<b>1169</b>
<b>Appendix E—Surface Roughness Produced by Common Production Methods . . . . .</b>	<b>1170</b>

<b>Appendix F—Wire Gages (Inches) . . . . .</b>	<b>1171</b>
<b>Appendix G—Sheet Metal Gages (Inches) . . . . .</b>	<b>1172</b>
<b>Appendix H—Sheet Metal Thicknesses (Millimeters) . . . . .</b>	<b>1173</b>
<b>Appendix I—Standard Allowances, Tolerances, and Fits . . . . .</b>	<b>1174</b>
Table 5—Allowances and Tolerances	
Preferred Hole Basis Fits . . . . .	1174
Allowances and Tolerances	
Preferred Shaft Basis Fits . . . . .	1174
Allowances and Tolerances	
Description of Preferred Fits . . . . .	1175
Table 6—American National Standard Fits—Running and Sliding Fits . . . . .	1176
American National Standard Fits—Clearance Locational Fits . . . . .	1178
American National Standard Fits—Transition Locational Fits . . . . .	1180
American National Standard Fits—Interference Locational Fits . . . . .	1181
American National Standard Fits—Force and Shrink Fits . . . . .	1182
Table 7—Metric Limits and Fits—Preferred Hole Basis Clearance Fits . . . . .	1184
Metric Limits and Fits—Preferred Shaft Basis Clearance Fits . . . . .	1186
Table 8—Metric Tolerance Zones—Metric Tolerance Zones for Internal (Hole) Dimensions . . . . .	1188
Metric Tolerance Zones—Tolerance Zones for External (Shaft) Dimensions . . . . .	1189
<b>Appendix J—Unified Screw Thread Variations . . . . .</b>	<b>1190</b>
Table 9—Unified Standard Screw Thread Series . . . . .	1191
<b>Appendix K—Metric Screw Thread Variations . . . . .</b>	<b>1192</b>
<b>Appendix L—ASTM and SAE Grade Markings for Steel Bolts and Screws . . . . .</b>	<b>1193</b>
<b>Appendix M—Cap Screw Specifications . . . . .</b>	<b>1194</b>
Table 10—Dimensions of Hex Cap Screws (Finished Hex Bolts) . . . . .	1194
Table 11—Dimensions of Hexagon and Spline Socket Head Cap Screws (1960 Series) . . . . .	1195
Table 12—Dimensions of Hexagon and Spline Socket Flat Countersunk Head Cap Screws . . . . .	1196
Table 13—Dimensions of Slotted Flat Countersunk Head Cap Screws . . . . .	1197
Table 14—Dimensions of Slotted Round Head Cap Screws . . . . .	1198
Table 15—Dimensions of Slotted Fillister Head Cap Screws . . . . .	1198

<b>Appendix N</b> —Machine Screw Specifications. . . . .	1199	<b>Appendix X</b> —Valve Specifications. . . . .	1226
Table 16—Dimensions of Slotted Flat Countersunk Head Machine Screws . . . . .	1199	Table 32—Wrought Steel Pipe and Taper Pipe Threads—American National Standard. . . . .	1229
<b>Appendix O</b> —Set Screw Specifications . . . . .	1200	Table 33—Cast Iron Pipe Screwed Fittings, 125 LB—American National Standard. . . . .	1230
Table 17—Dimensions of Hexagon and Spline Socket Set Screws . . . . .	1200	<b>Appendix Y</b> —PVC Pipe Dimensions in Inches. . . . .	1231
<b>Appendix P</b> —Hex Nut Specifications . . . . .	1202	<b>Appendix Z</b> —Rectangular and Round HVAC Duct Sizes . . . . .	1233
Table 18—Dimensions of Hex Nuts and Hex Jam Nuts . . . . .	1202	<b>Appendix AA</b> —Spur and Helical Gear Data . . . . .	1234
<b>Appendix Q</b> —Key and Keyseat Specifications . . . . .	1203	<b>Appendix BB</b> —CADD Drawing Sheet Sizes, Settings, and Scale Factors . . . . .	1235
Table 19—Woodruff Key Dimensions . . . . .	1203		
Table 20—Woodruff Keyseat Dimensions . . . . .	1205		
Table 21—Key Size Versus Shaft Diameter . . . . .	1207		
Table 22—Key Dimensions and Tolerances . . . . .	1208		
Table 23—Gib Head Nominal Dimensions . . . . .	1208		
Table 24—Class 2 Fit for Parallel and Taper Keys . . . . .	1209		
<b>Appendix R</b> —Tap Drill Sizes. . . . .	1210		
Table 25—Decimal Equivalents and Tap Drill Sizes (Letter and Number Drill Sizes). . . . .	1210		
<b>Appendix S</b> —Concrete Reinforcing Bar (Rebar) Specifications. . . . .	1211		
<b>Appendix T</b> —Common Welded Wire Reinforcement Specifications . . . . .	1212		
Table 26—Wire Size Comparison . . . . .	1212		
Table 27—Common Styles of Metric Welded Wire Reinforcement (WWR) . . . . .	1214		
<b>Appendix U</b> —ASTM A500 Square and Rectangular Structural Tubing Specifications. . . . .	1215		
<b>Appendix V</b> —Structural Metal Shape Designations . . . . .	1216		
Table 28—W, M, S, and HP Shapes— Dimensions . . . . .	1216		
Table 29—Channels American Standard and Miscellaneous—Dimensions . . . . .	1221		
<b>Appendix W</b> —Corrosion-Resistant Pipe Fittings . . . . .	1223		
Table 30—Weldings, Fittings, and Forged Flanges—Dimensions . . . . .	1223		
Table 31—Threaded Fittings and Threaded Couplings, Reducers, and Caps . . . . .	1225		



**CD Appendices:** There is a CD available at the back of Engineering Drawing and Design, 5e. The CD contains a variety of valuable features for you to use as you learn engineering drawing and design. The CD icon, placed throughout this textbook, directs you to features found on the CD.

**CD Appendix A**—American National Standards of Interest to Designers, Architects, and Drafters

**CD Appendix B**—ASME Standard Line Types

**CD Appendix C**—Dimensioning and Tolerancing Symbols and ASME Dimensioning Rules

**CD Appendix D**—Designation of Welding and Allied Processes by Letters

**CD Appendix E**—Symbols for Pipe Fittings and Valves

**CD Appendix F**—Computer Terminology and Hardware

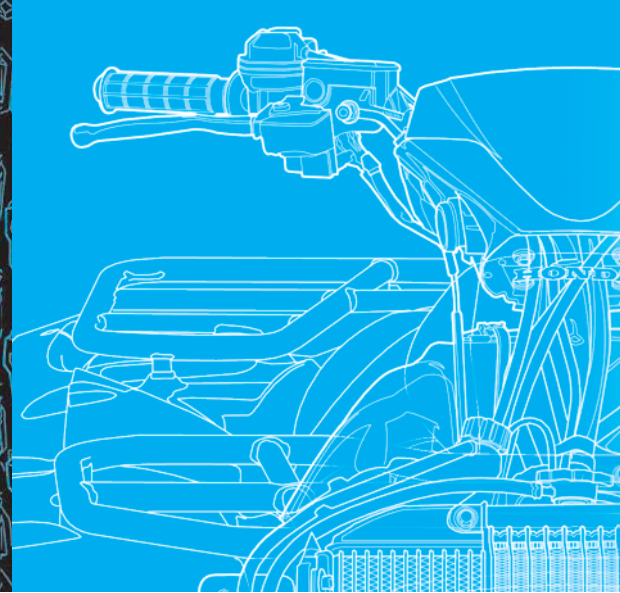
**CD Instructions:** Access the CD to view the CD chapters, appendices, chapter tests, and selected chapter problems:

- Place the CD in your CD drive.
- The CD should open (start) automatically.
- If the CD does not start automatically, pick the Start button in the lower left corner of your screen, and select Run, . . . followed by accessing the CD drive on your computer.
- Pick the desired chapter, appendix, test, or problem application button on the left side of the CD window.

**Glossary . . . . . 1239**

**Index . . . . . 1273**

# PREFACE



For more than 25 years, students have relied on *Engineering Drawing and Design* for its easy-to-read, comprehensive coverage of drafting and design instruction that complies with industry standards. The Fifth Edition continues its tradition of excellence with a multitude of actual quality industry drawings that demonstrate content coverage and the addition of new problems to the hundreds already on-hand for real-world, practical application. The engineering design process featured in this revision contains new material related to production practices that eliminate waste in all phases from design through manufacturing to marketing and distribution. Also described are practices that seek to improve the quality of process outputs by identifying and removing the causes of defects and minimizing manufacturing variables using quality management methods. An actual product design is taken from concept through manufacturing and to marketing. This is the most comprehensive product design analysis found in any discipline-related textbook. More than 1000 drafting and design problems are found throughout for basic to advanced challenging applications or for use individually and as team projects. New and current features of this textbook are described throughout this Preface.

## NEW TO THIS EDITION

- Expanded history of drafting feature.
- A new **Standards** feature box describes the specific standards used as related to chapter content.
- New **Engineering Design Applications** features written by industry professionals.
- Updated ASME and discipline-related standards.
- Updated CADD standards.
- Comprehensive coverage of ASME Y14.5-2009, *Dimensioning and Tolerancing*, including the most comprehensive geometric dimensioning and tolerancing content found in any textbook.
- CADD file templates for standard ASME inch and metric drawings, and architectural and civil inch and metric drawings.
- New material related to production practices that eliminate waste in all phases from design through manufacturing and to marketing and distribution.
- Current practices that seek to improve the quality of process outputs by identifying and removing the causes of defects and minimizing manufacturing variables using quality management methods.
- CADD theory and applications highlighted in an expanded, full-color chapter.
- New CADD applications that demonstrate advances made in this industry.
- Additional drafting and design problems that expand on the hundreds of problems already available throughout the textbook and on the **Student CD**.
- A new **Note** boxed feature provides you with expanded side information relative to specific features and current applications.
- Protecting the environment is one of the most important worldwide issue today. A new flagship feature called **Green Technology Application** is found throughout this textbook, providing current practical and experimental energy-efficient design, construction and manufacturing techniques resulting in a significant reduction in energy consumption and harmful emissions.
- Expanded **Glossary**. Every important term is defined in text and in the complete glossary.
- Improved content based on comprehensive technical reviews. Professional discipline-related technical reviewers were commissioned to evaluate content and provide input about accuracy and expanded coverage.
- Chapter tests are revised to correspond with new and updated content.
- Chapter problems have been evaluated for accuracy and new problems added to reflect changes in drafting standards, and for real-world applications provided by technical reviewers.
- Most manual drafting content is moved to the **Student CD**.
- Expanded material selection criteria, manufacturing processes, and engineering design applications have been added to the *Manufacturing Materials and Processes* chapter and throughout the textbook.
- Updated Web site research options have been added throughout.
- **Professional Perspectives** have been revised with real-world content written by industry professionals.

- The most comprehensive chapter-related PowerPoint® presentation found in any textbook is now available on the Instructor CD.
- Detailed course-specific syllabi on the Instructor CD.
- Chapter-correlated ExamView tests are available for alternate testing opportunities.

*Engineering Drawing and Design*, Fifth Edition, continues the proven success of its previous editions:

- Engineering Design Applications.
- CADD Applications throughout.
- Hundreds of illustrative examples supporting text content.
- Actual industry drawing examples to pull chapter content together.
- Professional Perspectives.
- Math Applications throughout and comprehensive design drafting–related math instruction on the **Student CD**.
- Step-by-step layout methods.
- Engineering layout techniques.
- Practical and useful appendices.
- More than 1000 real-world industry problems throughout.
- Chapter tests for examination or review on the **Student CD**.
- ASME drafting and print reading problems on the **Student CD**.
- Comprehensive Instructor CD.

*Engineering Drawing and Design* presents engineering drafting standards developed by the ASME and accredited by the American National Standards Institute (ANSI). This textbook also references International Organization for Standardization (ISO) engineering drafting standards and discipline-specific standards when appropriate, including American Welding Society (AWS) standards, the American Society for Testing Materials (ASTM), the American Institute for Steel Construction (AISC), the Construction Specifications Institute (CSI), and the United States National CAD Standard (NCS). Also presented, when appropriate, are standards and codes for specific engineering fields. One important foundation to engineering drawing and design, and the implementation of a common approach to graphics nationwide, is the standardization in all levels of drawing and design instruction. Chapter 1, *Introduction to Engineering Drawing and Design*, provides a detailed introduction to drafting standards, and specific content-related standards are described throughout this textbook. When you become a professional, this text will serve as a valuable desk reference.

## AMERICAN DESIGN DRAFTING ASSOCIATION (ADDA)-APPROVED PUBLICATION



tification Standards and the ADDA Certified Drafter Examination

The content of this text is considered a fundamental component of the design drafting profession by the American Design Drafting Association. This publication covers topics and related material as stated in the ADDA Curriculum Cer-

Review Guide. Although this publication is not conclusive with respect to ADDA standards, it should be considered a key reference tool in pursuit of a professional design-drafting career.

## ENGINEERING DRAWING AND DESIGN CURRICULUM OPTIONS

The conversational-style content is easy to read and easy to use. This textbook is comprehensive and can be used in the entire curriculum. The chapters can be used as presented or rearranged to fit any of the following courses:

- Drafting Fundamentals
- Engineering Drafting
- The Engineering Design Process
- Engineering Graphics
- Computer-Aided Design and Drafting (CADD)
- Mechanical Drafting
- Descriptive Geometry
- Manufacturing Materials and Processes
- Welding Processes and Weldment Drawings
- Geometric Dimensioning and Tolerancing (GD&T)
- Tool Design
- Mechanisms: Linkages, Cams, Gears, and Bearings
- Belt and Chain Drives
- Pictorial Drawings and Technical Illustration
- 3-D CAD and Modeling, Animation, and Virtual Reality
- Structural Drafting
- Civil Drafting
- Industrial Pipe Drafting
- Heating, Ventilating, and Air-Conditioning (HVAC)
- Pattern Development
- Precision Sheet Metal Drafting
- Fluid Power
- Engineering Charts and Graphs
- Electrical Drafting
- Electronics Drafting
- Drafting Math

## CHAPTER FORMAT

Each chapter provides realistic examples, illustrations, and related tests and problems. The examples illustrate recommended drafting and design presentation based on ASME standards and other related national standards and codes, with actual industry drawings used for reinforcement. The correlated text explains drawing techniques and provides professional tips for skill development. Step-by-step examples provide a logical approach to setting up and completing the drawing problems. Each chapter has the following special features.

### Engineering Design Application

The Engineering Design Application leads the content of every chapter. This section gives you an early understanding of the



type of engineering project that is found in the specific design and drafting area discussed in the chapter.

THE ENGINEERING DESIGN APPLICATION

You should always approach an engineering drafting problem in a systematic manner. As an entry-level drafter, create sketches and written notes to plan how you propose to solve the problem. You are also often given engineering sketches and notes to interpret. Engineering sketches can be difficult to read. This is typical because engineers normally do not have the time or the skills to prepare a very neat and accurate sketch. Actual engineering sketches can be out of proportion and missing information. Dimensions on engineering sketches often do not comply with ASME or other related standards. Your responsibility is to convert the engineer's communication into a formal drawing that is accurate and drawn to proper standards. Do as much work as you can based on the given sketches and related information, but ask the engineer for help if you discover issues that are difficult to interpret or seem to be inaccurate. Much of the work you do in engineering drafting contains geometry and related geometric characteristics. Many geometric characteristics are basic, such as drawing circles and arcs, but many can be complicated, such as compound curves. Refer to the engineer's sketch shown in Figure 7.1 as you follow these layout steps:

- STEP 1** Do all preliminary layout work using construction lines on a construction layer or line type that will not display when finished. Begin by establishing the centers of the Ø57 and Ø25.5 circles and then draw the circles. The Ø symbol represents a circle's diameter.
- STEP 2** Draw the concentric circles of Ø71.5 and Ø40.
- STEP 3** Locate and draw the 6X R7.5 arcs and then use tangencies to draw the R3 radii arcs with the outside arcs.
- STEP 4** Draw the 2X R7 arcs tangent to the large inside arcs.
- STEP 5** Draw the centerlines for the 6X Ø7 circles and then draw the circles from the established center

**STEP 6** Draw all centerlines on the appropriate layer, such as the CENTERLINE layer. Complete all visible object lines by trimming and extending as needed. Make sure all visible lines are on the appropriate layer, such as the OBJECT layer. Erase unwanted features. Turn off or freeze the construction layer. Figure 7.2 shows the finished drawing.

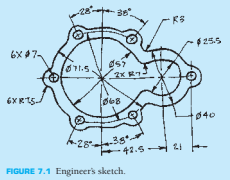


FIGURE 7.1 Engineer's sketch.

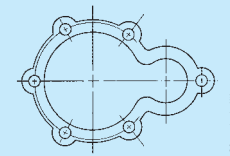


FIGURE 7.2 The complete drawing (without dimensions) for engineer's sketch shown in Figure 7.1.

ENGINEERING DESIGN APPLICATION

Standards

Specific drafting standards are identified throughout the textbook as they relate to chapter content.

STANDARDS

**ASME** The primary standard published by the American Society of Mechanical Engineers (ASME) is ASME Y14.5-2009, which is titled *Dimensioning and Tolerancing*. This standard establishes uniform practices for stating and interpreting dimensioning, tolerancing, and related requirements for use on engineering drawings and related documents. The standard ASME Y14.5.1, *Mathematical Definition of Dimensioning and Tolerancing Principles*, provides a mathematical definition of CD&T for the application of ASME Y14.5. ASME Y14.5.2, *Certification of Geometric Dimensioning and Tolerancing Professionals*, establishes certification requirements for a Geometric Dimensioning and Tolerancing Professional (GDTP). The standard ASME Y14.31, *Undimensioned Drawings*, provides the requirements for undimensioned drawings that graphically define features with true geometry views without the use of dimensions. ASME Y14.43, *Dimensioning and Tolerancing Principles for Gages and Fixtures*, provides practices for dimensioning and tolerancing of gages and fixtures used for the verification of maximum material condition. The standard that controls general dimensional tolerances found in the dimensioning and tolerancing block or in general notes is ASME Y14.1, *Decimal Inch Drawing Sheet Size and Format*, and ASME Y14.1M, *Metric Drawing Sheet Size and Format*.

STANDARDS

CADD Applications

CADD Applications are provided in each chapter to illustrate how the use of CADD is streamlining the design and drafting process. Both 2-D and 3-D CADD Applications demonstrate advances made in discipline-related discussions and examples.

CADD APPLICATIONS

DRAWING ACCURACY

One important aspect of CADD technology is accuracy. Multiview and auxiliary view drawings produced with CADD should be perfect if you use appropriate CADD techniques and follow correct drafting standards throughout the drawing process. The reason for high accuracy involves the capabilities of computer hardware and software and the fact that the computer displays the mathematical counterpart of the true geometry. Drawing views are a representation of the mathematical coordinates of the design problem. Therefore, the accuracy potential of the computer controls drawing accuracy.

Figure 9.25 shows an example of a drawing of a tubular mainframe part. A front view and two partial auxiliary views represent the part completely. CADD offers tools and options that allow you to construct the geometry of the front view quickly and accurately. You can then easily project the auxiliary views from the inclined surfaces using a viewing plane exactly perpendicular to the inclined surfaces. The final step is to add dimensions associated with view objects. The computer stores data about each object. Any changes you make to the drawing update in the associated views and dimensions.

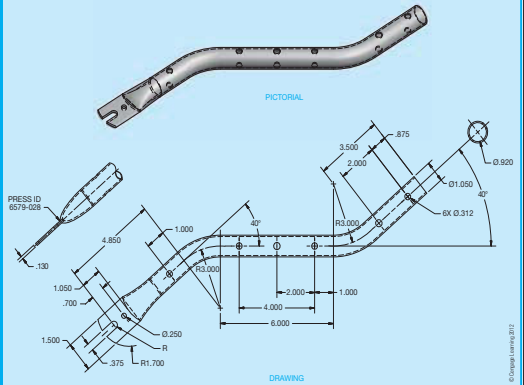


FIGURE 9.25 An example of a part with a front view and two auxiliary views.

CADD APPLICATIONS

Note

A special Note box feature is used where appropriate to provide additional explanation, helpful tips, professional information, or alternate practice.



**NOTE:** Numbered series threads are major thread diameters less than 1/4 in. These threads are specified by the screw number 0 through 12, which is the gage diameter from which the thread is manufactured. Numbered series threads are designated by their number followed by the decimal value of the major diameter in parenthesis. For example, 10 (.190)-32 UNF-2A.

NOTE

Step-by-Step Drafting Procedures and Techniques

Each chapter has step-by-step instructions for applying drafting techniques to the chapter-related content.

- STEP 1** Draw duct runs using thick .03 or .035 in. (0.7 or 0.9 mm) line widths.
- STEP 2** Label duct sizes within the duct when appropriate or use a note with a leader to the duct in other situations.
- STEP 3** Duct sizes can be noted as 22 x 12 (360 x 300 mm) or 22/12, where the first number, 22, is the duct width, and the second numeral, 12, indicates the duct depth.
- STEP 4** Place notes on the drawing to avoid crowding. Aligned dimensioning can be used where horizontal notes read from the bottom of the sheet and vertical notes read from the right side of the sheet. Make notes clear and concise.
- STEP 5** Refer to schedules to get specific drawing information that is not otherwise available on the sketch.
- STEP 6** Label equipment either blocked out or bold to clearly stand out from other information on the drawing.

STEP-BY-STEP DRAFTING PROCEDURES AND TECHNIQUES

Drafting Templates



Standard CADD file template with predefined drafting settings are available on the Student CD. Use the templates to create new designs, as a resource for drawing

and model content, or for inspiration when developing your own templates. The ASME-Inch and ASME-Metric drafting templates follow ASME, ISO, and related mechanical drafting standards. Architectural and civil drafting templates are also available for use with your electrical, piping, HVAC, structural, and civil drawings. Drawing templates include standard sheet sizes and formats and a variety of appropriate drawing settings and content. You can also use a utility such as the AutoCAD DesignCenter to add content from the drawing templates to your own drawings and templates. Consult with your instructor to determine which template drawing and drawing content to use.

**Drafting Templates**

To access CADD template files with predefined drafting settings, go to the Student CD, select **Drafting Templates** and then select the appropriate template file. The ASME-Inch and ASME-Metric drafting templates follow ASME, ISO, and related mechanical drafting standards. Drawing templates include standard sheet sizes and formats and a variety of appropriate drawing settings and content. You can also use a utility such as the AutoCAD DesignCenter to add content from the drawing templates to your own drawings and templates. Consult with your instructor to determine which template drawing and drawing content to use.

DRAFTING TEMPLATES

To access CADD file templates with predefined drafting settings, go to the Student CD, select **Drafting Templates**, and then select the appropriate file template.

## Math Applications

Practical drafting-related math applications and math problems appear in every chapter and are correlated with the chapter content. These elements provide examples and instruction on how math is used in a specific discipline.

MATH APPLICATIONS

**DESIGNING AN OBSERVATION PLATFORM**

**Problem:** Suppose a building code states that the rise between stair treads cannot exceed 8" for a 12" tread. Find the minimum distance for dimension L and a corresponding angle A in Figure 22.101 of an observation platform.

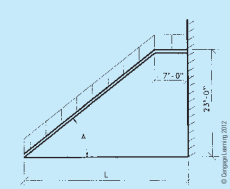
**Solution:** Geometrical figures are similar when they have the same shape. They are congruent when they have the same shape and size. When two triangles are similar, proportional equations can be written. In this design problem, you have similar triangles: the large staircase and the smaller single tread (see Figure 22.102).

Set up a proportion

$$\frac{23}{x} = \frac{8}{12}$$

which gives

$$x = 34.5'$$



**FIGURE 22.101** Observation platform.

**FIGURE 22.102** Two similar triangles. © Cengage Learning 2012

The dimension L is an additional 7':

$$L = 34.5 + 7 = 41.5' \text{ or } 41'-6''$$

Also, because we are dealing with right triangles, angle A can be found by the application of one trig function:

$$A = \text{Inv tan } \frac{8}{12} = 33.7'$$

It is often necessary for the drafter to calculate the weight and cubic yard of concrete for bills of materials, cost estimates, and construction purposes. The following formulas can be used to make these calculations:

(Length × Width × Height) × 150 = Total weight  
 (Length × Width × Height) ÷ 27 = Cubic yard

**Problem:** Given a precast concrete panel with the dimensions 18'-4" long, 1'-4" wide, and 2'-0" high, calculate the weight in pounds and the volume in yards.

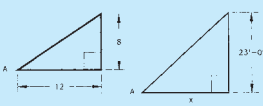
**Solution:**

$$18'-4" \times 1'-4" \times 2'-0" = 48.88889 \text{ cubic feet}$$

$$48.88889 \times 150 = 7333.3333 \text{ lb}$$

$$48.88889 \div 27 = 1.81 \text{ cubic yards}$$

If there are holes or cutouts, then it is necessary to calculate the combined volume and weight of these and subtract them from the total.



MATH APPLICATIONS

## Engineering Drawing and Design Math Applications

This content provides comprehensive math instruction for engineering design and drafting and related fields. The content parallels the math applications and problems in chapters

throughout this textbook. The material is presented with numerous examples in a manner that is easy to use and understand.



For complete information and instructions for *Engineering Drawing and Design Math Applications*, go to the Student CD, select Reference Material and Engineering Drawing and then Design Math Applications.

## Metric Applications

Values presented in the content are in inches and are identified with (in.). Related metric values are given in parentheses using the appropriate equivalencies. Specific metric applications are given throughout this textbook. Metric applications are a very important part of the drafting and design industry. Chapter ending problems are also given for inch and metric applications and are labeled accordingly with (inch) or (metric). Illustrative examples provided throughout the text are displayed using metric values in millimeters, unless otherwise specified.

## Chapter-Related Tests

Related chapter tests appear on the Student CD for examination or review. The tests ask for short answers, sketches, or drawings to confirm your understanding of chapter content.



To access a chapter test, go to the Student CD, select **Chapter Tests and Problems**, and then the chapter. Answer the questions with short complete statements, sketches, or drawings as needed. Confirm the preferred submital process with your instructor.

## Chapter-Related Problems

Each chapter ends with numerous real-world drafting and design problems for you to practice what you have learned. This book contains more than 1000 problems that range from basic to complex. Problems are presented as real-world engineering sketches, pictorial engineering layouts, and actual industry projects. Advanced problems are given for challenging applications or for use as team projects. Problems are so numerous that they cannot all be placed in the textbook. Some problems are placed on the Student CD for access. Most problems require you to use standards sheet sizes, borders, and sheet blocks related to the specific discipline.

**Chapter 9 Auxiliary Views Test**

To access the Chapter 9 test, go to the Student CD, select **Chapter Tests and Problems**, and then **Chapter 9**. Answer the questions with short, complete statements, sketches, or drawings as needed. Confirm the preferred submital process with your instructor.

**Chapter 9 Auxiliary Views Problems**

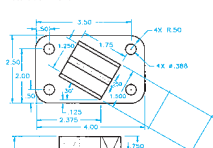
Parts 1, 2, and 3: Problems 9.1 Through 9.14

To access the Chapter 9 problems, go to the Student CD, select **Chapter Tests and Problems** and **Chapter 9**, and then open the problem of your choice or as assigned by your instructor. Solve the problems using the instructions provided on the CD, unless otherwise specified by your instructor.

**PROBLEM 9.15** Primary auxiliary view (in.)  
 Title: Angle V-block  
 Material: SAE 4320

**Part 4: Problem 9.15**

This problem provides you with dimensioned pictorial views and a proposed start for your multiview and auxiliary view layout. Draw the required multiview and auxiliary views. Use the given dimensions to create your final drawing. Set up your drawings with a properly sized sheet, border, and sheet block. Properly complete the information in the title block. Do not draw the pictorial view unless required by your instructor. Do not draw the dimensions.



CHAPTER-RELATED TESTS AND PROBLEMS



To access the chapter problems, go to the **Student CD**, select **Chapter Tests and Problems**, select the chapter, and then open the problem of your choice or as assigned by your instructor. Solve the problems using the instructions provided with this chapter or on the CD, unless otherwise specified by your instructor.

## Professional Perspective

The Professional Perspective is a boxed article at the end of chapters that explains how to apply the skills and knowledge discussed in the chapter to a real-world, job-related setting. Professional perspectives are written by industry professionals and give you an opportunity to hear what actual engineers, designers, and drafters have to say about the design drafting industry and what you can expect as a drafter in the chapter-related discipline.

**PROFESSIONAL PERSPECTIVE**

The field of process piping design and drafting can provide an excellent opportunity for a person to enter engineering. Many consulting engineering companies pay for the education of employees who want to upgrade their skills. This additional education can help as a path toward becoming a designer, technician, or engineer, because you can get valuable job training while working toward an advanced degree.

Piping drafters are often required to work with welders, civil and steel consultants, equipment designers, geological engineers, geophysical engineers, and electrical engineers. Portions of drawings commonly come from different departments, or from different companies or contractors to establish the complete project. Drafters must be able to communicate with all of these people.

A good piping drafter, designer, or engineer is one who is aware of the actual job-site requirements and problems. These field situations are often considerably different from the layout that is designed in the office. Therefore, if you are planning to work in the industrial piping profession, do your best to work on projects in which you can gain field experience. Fieldwork is especially important when adding new equipment and pipe in an existing facility. There are many stories of inexperienced piping designers who have created a design in the office and then gone to the field to find a new 4" pipe routed directly through an existing 12" pipe. Errors like this can happen to anyone, but they happen less often with valuable practical experience.

PROFESSIONAL PERSPECTIVE

## Web Site Research

Web Site Research is a feature that is placed at the end of chapters, providing key Web sites where you can do additional research, find standards, and seek manufacturing information or vendor specifications related to the chapter content. Web sites and links are current but may change after the date of this publication.

**WEB SITE RESEARCH**

Use the following Web sites as a resource to help find more information related to engineering drawing and design and the content of this chapter:

Address	Company, Product, or Service
www.ab.com	Allen-Bradley: industrial electrical controls
www.aise.org	American Institute of Steel Construction
www.allamericanproducts.com	All American Products: tooling components
www.aluminum.org	Aluminum Association
www.americanchemistry.com	American Chemistry Council
www.asme.org	American Society of Mechanical Engineers
www.astm.org	American Society for Testing Materials International: create standards for materials, products
www.azom.com	The A to Z of materials
www.carrlane.com	Carr Lane Manufacturing: tooling components
www.copper.org	Copper Development Association
www.destaco.com	De-Sta-Co Industries: toggle clamps
www.emtec.org	Edison Materials Technology Center: manufacturing materials research
www.ides.com	Plastic materials directory
www.ides.com	IDES Inc.: plastic materials information
www.industrialpress.com	Machinery's Handbook: manufacturing materials, processes, specifications, and data
www.jergensinc.com	Jergens Inc.: tooling components
www.matweb.com	MatWeb: online material property data

(Continued)

WEB SITE RESEARCH

## Green Technology Application

Protecting the environment is one of the most important worldwide issues today. A new flagship feature called **Green Technology Application** is found throughout this textbook, providing

current practical and experimental energy-efficient design, construction and manufacturing techniques resulting in a significant reduction in energy consumption. As industry grows to meet the demands of our increasing population, there is a strong need to take care of the environment and allow for current and future development. As a student, it is very important for you to learn what is available today and to find ways to improve energy efficiency in design and construction into the future in an effort to protect the earth. National and local programs have been established to meet this need. Modern advances are available to designers, builders, manufacturers and owners who want to use green technology and make the most of environmental protection in our industries. A focus is on **Sustainable development** that meets the needs of the present without compromising the ability of future generations to meet their own needs. Sustainability includes projects that can be produced without permanent and unacceptable change in the natural environment on which it and other economic activities depend, over the life of the project.

**GREEN TECHNOLOGY APPLICATION**

**ELECTRICITY GENERATION FROM WIND POWER**


The following information was taken, in part, from the Southwest Windpower Web sites located at [www.windenergy.com](http://www.windenergy.com) and [www.skystreamenergy.com](http://www.skystreamenergy.com). Skystream 3.7<sup>®</sup>, developed by Southwest Windpower in collaboration with the United States Department of Energy National Renewable Energy Laboratory (NREL), is the newest generation of residential wind technology. Skystream is the first all-inclusive wind generator with built-in controls and inverter designed specifically for utility grid-connected residential and commercial use.

**RESIDENTIAL WIND POWER ELECTRICITY GENERATION**

Skystream is a small wind generator that allows home and business owners to harness the free power of the wind and take control of their energy bills like never before. Early adopters have reported a savings of more than 50% on their energy bills. Figure 20.38 shows the Skystream 3.7.

**Specifically for Grid Connectivity**

The Skystream is specifically designed for utility grid-connected homes and businesses. In certain states, consumers can take advantage of net metering, which is the sale of unused energy back to the power grid as shown in Figure 20.39.



Courtesy Southwest Windpower

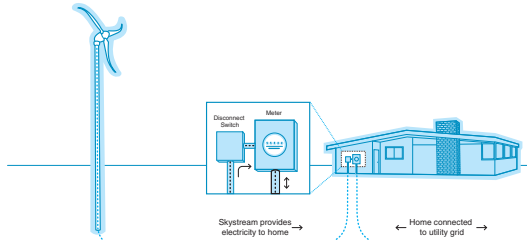


FIGURE 20.39 How the Skystream 3.7 wind power electricity generator works. Courtesy Southwest Windpower

GREEN TECHNOLOGY APPLICATION

## Related Appendices

Each chapter refers to the key appendices for your reference and use in problem solving. The appendices contain the types of charts, tables, and information used daily in the engineering design and drafting environment. Appendices can be copied for use as desk references as needed. These appendices include common fastener types and data, fits and tolerances, metric conversion charts, tap drill charts, and other manufacturing information used on engineering drawings. There is a complete list of abbreviations and a comprehensive glossary. It is also recommended that you learn to use other resources such as the *Machinery's Handbook*, ASME standards, other specific industry standards related to chapter content, and appropriate vendor's catalogues.

## Glossary

The most comprehensive glossary available is at the end of this textbook. Glossary terms are **bold** in chapter content, where they are defined immediately and also placed in the glossary for additional reference. Each term is clearly defined using descriptions that are related to engineering drafting and design applications.


## PULLING IT ALL TOGETHER

Looking at actual industry drawings is an excellent way to pull together what you have learned. Chapters have actual industry drawings placed along with other illustrative examples so you can see how the specific application is accomplished in the real world. Chapters also often end with an example of a fairly complex industry drawing, allowing you to see how previously learned content is applied in industry. These drawings have been selected for their quality and characteristics related to the chapter content and their compliance with national and industry standards. You should spend as much time as possible looking at actual industry drawings in an effort to help you visualize the thought that goes into creating drawings.

## STUDENT CD ACCOMPANYING ENGINEERING DRAWING AND DESIGN

### Material on the Companion Student CD

The Student CD available at the back of *Engineering Drawing and Design*, Fifth Edition, contains a variety of valuable features for you to use as you learn engineering drawing and design.

The Student CD icon , placed throughout this textbook, directs you to features found on the Student CD.

How to use the Student CD instructions are provided in Section 7 on pages 1157 through 1160.

### Student CD Contents

- Additional Appendices
- ASME Print Reading or Drawing Exercises
- Chapter Tests and Problems
- Drafting Templates
- Reference Material
  - Descriptive Geometry I
  - Descriptive Geometry II
  - Engineering Charts and Graphs
  - Engineering Drawing and Design Math Applications
  - Fluid Power
- Supplemental Material

## INDUSTRY APPROACH TO PROBLEM SOLVING

Your responsibility as a drafter is to convert engineering sketches or instructions to formal drawings. This text explains how to prepare drawings from engineering sketches by providing you with the basic guides for layout and arrangement in a knowledge-building format. One concept is presented before

the next is introduced. Problem assignments are presented in order of difficulty within each chapter and throughout the text. The concepts and skills learned in one chapter are built on and used in following chapters; by the end of the textbook, you have the ability to solve problems using a multitude of previously learned discussions, examples, applications, and activities. The problems are presented as pictorial or actual industrial layouts in a manner that is consistent with the engineering environment. Early problems provide suggested layout sketches. It is not enough for you to duplicate drawings from given assignments: You must be able to think through the process of drafting development. The goals and objectives of each problem assignment are consistent with recommended evaluation criteria and based on the progression of learning activities.

## COMPUTER-AIDED DESIGN AND DRAFTING

Computer-aided design and drafting (CADD) is presented throughout this textbook. CADD topics include:

- CADD terminology and hardware supplement found on the Student CD.
- CADD software used in drafting and design.
- CADD standards.
- CADD practices for specific engineering drafting applications.
- 2-D and 3-D CADD techniques and applications used in industry.
- Increased productivity with CADD.
- The CADD environment in industry.

## DESIGN PROJECTS

Chapters contain projects that let you practice your design knowledge and skills. These advanced problems require you to systematically determine a desired solution. There are challenges in manufacturing knowledge, tolerances, accuracy, and other issues related to the specific discipline. Advanced problems may have errors intentionally introduced as a challenge for you to find and correct.

## TEAM PROJECTS

Some projects are designed to be solved in a team approach. Groups of students can develop their own team organization and establish the best course of action to assign team member responsibilities and create the desired solutions.

## COURSE PLAN

### Section 1: Introduction to Engineering Drawing and Design

#### Introduction to Engineering Drawing and Design

Chapter 1 provides a detailed look at drafting as a profession and includes a brief history, occupations, professional organizations, occupational levels, opportunities, career requirements,

seeking employment, CADD issues, workplace ethics, copyrights, patents, trademarks, and a **Professional Perspective** from a leading person in the drafting and design industry.

### Drafting Equipment, Media, and Reproduction Methods

Chapter 2 covers drafting equipment, materials, and reproduction methods for drafting, with specific instruction on how to use tools and equipment provided in the Supplemental Material for Chapter 2 on the Student CD. The major emphasis of this chapter is the discussion, description, and professional use of ASME-recommended drawing sheet sizes, border lines, and sheet blocks.

### Computer-Aided Design and Drafting (CADD)

Chapter 3 introduces computer-aided design and drafting (CADD) and related technology. This chapter provides CADD software manufactures and products, explains and compares CADD formats, and identifies disciplines and industry concepts related to CADD. The use of prototyping, animation, and virtual reality in the design process is covered. This chapter demonstrates the variety of CADD techniques found in industry, including 2-D drafting, surface modeling, and solid modeling. Content also includes information about CADD standards, productivity with CADD, and sustainable design and CAD practices. For computer terminology and hardware information, go to the Supplemental Material for Chapter 3 on the Student CD.

### Manufacturing Materials and Processes

Chapter 4 gives you the most complete coverage of manufacturing materials and processes found in any textbook of this type. The chapter includes product development, manufacturing materials, material selection, sustainable materials, material numbering systems, hardness and testing, casting and forging methods, metal stamping, manufacturing and design of plastics, design and drafting related to manufacturing processes, complete machining processes, computer numerical control, computer-integrated manufacturing, machine features and drawing representations, surface texture, design of machine features, and statistical process control. A solid understanding of materials and processes will prove to be a valuable asset as you continue your education in drafting and design using this textbook.

## Section 2: Fundamental Applications

### Sketching, Lines, Lettering, and Drafting Geometry

Chapters 5, 6, and 7 explain and detail sketching, lines, lettering, and drafting geometry extensively. These chapters show you how to properly draw lines and lettering in accordance with ASME standards. The sketching techniques you learn in Chapter 5 will continue to be used throughout your drafting and design education and into the profession. Sketching skills are important in preparation for creating drawings and for

communication with others in the industry. Lines and lettering make up the foundation of engineering drawings. Proper application of lines and lettering based on correct national standards is important for you to learn now and use throughout your career. Drafting geometry is the basis of all geometric shapes and drafting applications. These fundamentals will be used throughout your drafting and design education and into the profession.

## Section 3: Drafting Views and Annotations

### Multiviews and Auxiliary Views

Chapters 8 and 9 provide a complete study of multiviews and auxiliary views, in accordance with ASME standards, with accurate and detailed instruction on topics such as view selection and placement, first- and third-angle projection, and viewing techniques. These chapters provide step-by-step examples that describe how to lay out multiview and auxiliary view drawings.

### Dimensioning and Tolerancing

Chapter 10 is developed in accordance with ASME Y14.5-2009 and provides complete coverage on dimensioning systems, rules, specific and general notes, tolerances, symbols, inch and metric limits and fits, drawing specifications, dimensioning castings, forgings, plastic drawings, and dimensioning for computer-aided design (CAD) and computer-aided manufacturing (CAM). You are provided with a step-by-step example showing how to lay out a fully dimensioned multiview drawing. Additional coverage includes the basics of tool design and drafting applications.

### Fasteners and Springs

Chapter 11 presents fastener and spring terminology. The complete range of fastening devices is covered, including screw threads, thread cutting, thread forms, thread representations and notes, washers, dowels, pins, rings, keys and keyseats, and rivets. Types of springs, spring ends, and spring applications are included. Fasteners and springs are covered after dimensioning practices so you can apply dimensions to your spring drawings, and then sectioning techniques follow so you can apply fastening systems to future drawings.

### Sections, Revolutions, and Conventional Breaks

Chapter 12 explains every type of sectioning practice available to the mechanical engineering drafter. This chapter also includes proper representation of sectioned features that should remain unsectioned in a sectional view, conventional revolutions, and conventional breaks. Section views can be used as needed in drafting problems throughout the rest of this textbook.

### Geometric Dimensioning and Tolerancing

Chapter 13 provides the most comprehensive coverage found in any textbook, including geometric tolerancing symbols,

terms, and applications presented in accordance with ASME Y14.5-2009. This chapter features datums, feature control, basic dimensions, geometric tolerances, material condition, position tolerance, virtual condition, geometric tolerancing applications, and CADD usage. Geometric dimensioning and tolerancing education follows dimensioning and sectioning so you can apply these concepts as needed throughout your continued drafting and design education.

## Pictorial Drawings and Technical Illustrations

Chapter 14 provides a complete review of three-dimensional drafting techniques used in drafting. The chapter includes extensive discussion of isometric, diametric, trimetric, perspective, exploded drawings, and shading methods. Current technical illustration practices are described and illustrated. The content of this chapter can be introduced here or earlier in your education, depending on course objectives.

## Section 4: Working Drawings

### Working Drawings

Working drawings, introduced in Chapter 15, pull together everything you have learned, including multiviews, auxiliary views, sectioning practices, dimensioning techniques, and fasteners, allowing you to draw a complete product with all of its individual parts, an assembly of the product, and a parts list that includes all of the parts listed, identified, and correlated with the detail and assembly drawings. Working drawings include details, assemblies, and parts lists, along with the most extensive discussion on engineering changes available.

Also provided is a complete analysis of how to prepare a set of working drawings from concept to final product and how to implement an engineering change. This is the most comprehensive engineering change content found in any textbook. A large variety of problem projects are based on actual products found in a variety of applications in the real world. The working drawing section continues with assemblies created with linkages, cams, gears, bearings, and weldments.

### Mechanisms: Linkages, Cams, Gears, Bearings, Belt and Chain Drives

Chapters 16 and 17 provide you with extensive coverage of linkage mechanisms, cams, gears, bearings, and belt and chain drives. The content includes how to design and draw these features as details and in assembly. Special attention is given to design calculations for gears and cams. Detailed information is given on the selection of bearings and lubricants. The use of vendors' catalog information is stressed in the design of belt and chain drive systems. Actual mechanical engineering design problems are provided for gear train and cam plate design.

### Welding Processes and Representations

Welding coverage in Chapter 18 provides an in-depth introduction to processes, welding drawings and symbols, weld types, symbol usage, weld characteristics, weld testing, welding specifications, and prequalified welded joints.

## Section 5: Specialty Drafting and Design

### Engineering Drafting and Design Fields of Study

Chapters 19 through 24 provide you with instruction in specific engineering drawing and design fields. These chapters can be used individually for complete courses or combined with previous chapters as needed to fit your curriculum objectives. These chapters contain comprehensive instruction, problems, and tests. These fields include:

**Precision Sheet Metal Drafting**—Chapter 19 provides complete coverage of the different formats used to create precision sheet metal drawing in industry. Coverage continues with bend allowances calculations, and characteristics found in precision sheet metal drawings.

**Electrical and Electronics Drafting**—Chapter 20 provides the only coverage of its type in electrical power transmission. The content is specific to electrical drafting of wiring diagrams, cable assemblies, one-line and elementary diagrams, electrical power system symbols, plot plans, bus layouts, ground layouts, conduit layouts, electrical floor plan symbols, power-supply plans, and schematics. Chapter 20 also offers detailed content related to the electronics industry. Topics include block diagrams, electronic components and symbols, engineer's sketches, component numbering, operational amplifier schematics, integrated circuit systems, logic diagrams, large-scale integration schematics, surface-mount technology, printed circuit technology, electronics artwork, layers, marking, drilling, assembly drawings, photo drafting, and pictorial diagrams.

**Industrial Process Pipe Drafting**—Chapter 21 provides explanations and detailed examples of pipe and fittings, piping symbols, valves and instrumentation, pumps, tanks and equipment, flow diagrams, piping plans and elevations, piping isometrics, and piping spools. Process flow diagrams (PFD) and a subset of PFD is the process and instrumentation diagram (P&ID) are described and illustrated with more details about the instrumentation schematics used in the plant.

**Structural Drafting**—Chapter 22 covers reinforced and precast concrete, truss and panelized framing, timbers, laminated beams, steel joists and studs, prefabricated systems, structural steel, structural welding, and structural details. You have the option of completing one of several sets of complete structural drawings for light commercial buildings.

**Heating, Ventilating, and Air-Conditioning (HVAC)**—Chapter 23 provides complete coverage of HVAC systems, heat exchangers, HVAC symbols, single- and double-line ducted systems, and working from an engineer's sketch to create HVAC plans, sections and details, and cutsheets. The chapter continues with common sheet metal pattern developments and sheet metal intersections using step-by-step layout procedures.

**Civil Drafting**—Chapter 24 discusses and describes the complete discipline of mapping, including legal descriptions, survey terminology, and drawing site plans. Civil

drafting includes road layout, cuts and fills, and plan and profile drawings. You will go through the step-by-step process for drafting a road layout, road cuts and fills, plan and profile drawings, site plan, topography contours, and a site grading plan.

## Section 6: Engineering Design

### The Engineering Design Process

The engineering design process chapter is placed at the end of the textbook specifically to allow you an opportunity to learn a vast amount about drafting and design theory and skills before proceeding with your own designs or the designs of your school or company.

Chapter 25 provides an introduction to several engineering design systems, including lean manufacturing and Six Sigma. Detailed coverage continues with step-by-step use of the phase gate design process. You will see how all aspects of the design process fit together. You will take the design of a product from engineering sketches through production, implementing CAD/CAM, parametric design, rapid prototyping, computer-aided engineering (CAE), concurrent engineering, collaborative engineering, reverse engineering, team projects, and other innovative topics. Creativity, collaboration, and the design process are emphasized in this chapter.

Much of the discussion derives from information obtained from Milwaukee Electric Tool Corporation. Paralleling the general design process information is the tracking of an actual new product design from concept through full-production manufacturing. The product used for this design sequence example is the Milwaukee Electric Tool Corporation's V28 Lithium-Ion Sawzall® reciprocating saw. An additional green technology product is taken from idea through design and drafting and into manufacturing and marketing.



## Section 7: Engineering Drawing and Design Student CD

### Reference Material: Comprehensive Resources

**Descriptive Geometry I**—Descriptive geometry is a drafting method used to study 3-D geometry with 2-D drafting applications where planes of projections analyze and describe the true geometric characteristics. Descriptive geometry principles are valuable for determining true shapes of planes, angles between two lines, two planes, or a line and a plane, and for locating the intersection between two planes, a cone and a plane, or two cylinders. Problems are solved graphically by projecting points onto selected adjacent projection planes in an imaginary projection system.

**Descriptive Geometry II**—This reference content continues from Descriptive Geometry I, allowing you to solve many engineering problems where the direction of lines and planes must be determined. The direction of lines and planes is identified in space by a variety of ways, depending on their uses.

**Engineering Charts and Graphs**—This reference content provides you with the most comprehensive coverage available on the design and drafting of engineering charts and graphs.

**Engineering Drawing and Design Math Applications**—This reference content provides you with comprehensive math instruction for engineering design and drafting and related fields. The content parallels the math applications and problems in chapters throughout this textbook. This supplemental material is presented with numerous examples in a manner that is easy to use and understand.

**Fluid Power**—This reference content provides you with complete coverage of fluid power drafting and design applications, including hydraulic, fluid power, and pneumatic terminology, rules, symbols, systems, and diagrams.

## CHAPTER LENGTH

Chapters are presented in individual learning segments that begin with basic concepts and build until each chapter provides complete coverage of each topic. The content of each chapter generally should be divided into logical teaching segments, providing you with an opportunity to create basic drawing as you progress into problems that are more complex.

## Applications


This text contains CADD discussion and examples, engineering layout techniques, working from engineer's sketches, professional practices, and actual industry examples. The problem assignments are based on actual real-world products and designs. Special emphasis has been placed on providing realistic problems. Problems are presented as 3-D drawings, engineering sketches, and layouts in a manner that is consistent with industry practices. Many of the problems have been supplied by industry. Each problem solution is based on the step-by-step layout procedures provided in the chapter discussions. Problems are given in order of complexity so you gain exposure to a variety of engineering experiences. Early problems recommend the layout to help you save time. Advanced problems require you to go through the same thought process that a professional faces daily, including drawing scale, sheet size and sheet block selection, view selection and layout, dimension placement, sectioning placement, and many other applications. All problems should be solved in accordance with recommended ASME or other discipline-related industry practices and standards.

## A Special Notice About Problems

You should always approach a problem with critical analysis based on view selection and layout and dimension placement when dimensions are used. Do not assume that problem information is presented exactly as the intended solution. Problems can be deliberately presented in a less-than-optimal arrangement. Beginning problems provide given layout examples, allowing you to solidify your knowledge before advancing on your own. Advanced problems often require you to evaluate the accuracy of provided information. Never

take the given information or accuracy of the engineering sketch for granted. This is also true as you progress into industry.




Problems are found in the textbook following each chapter, and additional chapter problems are located on the **Student CD** accompanying this textbook. A wide range of problems are available in both locations. In some cases, basic problems are placed on the **Student CD**, allowing you to copy the problems for drawing solution. In other cases, advanced problems are found on the **Student CD** if you want an extra challenge and if instructors want to provide a variety of practical opportunities for students. Chapter problems conclude with content-related math problems that are based on the Math Application found at the end of each chapter. Watch for the  identifying problems found on the **Student CD**. Instructions, such as the following, direct you to the **Student CD** problems:

## Chapter Problems



To access the Chapter problems, go to the **Student CD** and select **Chapter Tests and Problems**, then **Chapter**, and then open the problem of your choice or as assigned by your instructor. Solve the problems using the instructions provided with this chapter or on the CD, unless otherwise specified by your instructor.

## Using Chapter Tests

Chapter tests provide complete coverage of each chapter and can be used for instructional evaluation, as study questions, or for review. The chapter tests are located on the **Student CD** accompanying this textbook. Watch for the . Instructions, such as the following, direct you to the CD test:

### Chapter Test



To access the Chapter test, go to the **Student CD**, select **Chapter Tests and Problems**, and then select **Chapter**. Answer the questions with short, complete statements, sketches, or drawings as needed. Confirm the preferred submittal process with your instructor.

## APPENDICES

The appendices contain the types of charts and information used daily in the engineering design and drafting environment. In addition to using the appendices found in this book, it is recommended that you learn to use other resources, such as the *Machinery's Handbook*, ASME standards, other specific industry standards related to chapter content, and appropriate vendors' catalogues. The textbook appendices include:

- Abbreviations
- Conversion Charts
- Mathematical Rules Related to the Circle
- General Applications of SAE Steels

- Surface Roughness Produced by Common Production Methods
- Wire Gages (Inches)
- Sheet Metal Gages (Inch)
- Sheet Metal Thicknesses (Millimeters)
- Standard Allowances, Tolerances, and Fits
- Unified Screw Thread Variations
- Metric Screw Thread Variations
- ASTM and SAE Grade Markings for Steel Bolts and Screws
- Cap Screw Specifications
- Machine Screw Specifications
- Set Screw Specifications
- Hex Nut Specifications
- Key and Keyseat Specifications
- Tap Drill Sizes
- Concrete Reinforcing Bar (Rebar) Specifications
- Common Welded Wire Reinforcement Specifications
- ASTM A500 Square and Rectangular Structural Tubing Specifications
- Structural Metal Shape Designations
- Corrosion-Resistant Pipe Fittings
- Valve Specifications
- PVC Pipe Dimensions in Inches
- Rectangular and Round HVAC Duct Sizes
- Spur and Helical Gear Data
- Metric Coordinate to Positional Tolerance Conversion
- Inch Coordinate to Positional Tolerance Conversion
- CADD Drawing Sheet Sizes, Settings, and Scale Factors

### Student CD Appendices



For appendices found on the **Student CD**, go to the **Student CD**, select **Appendices**, and select the desired appendix.

Access the **Student CD** accompanying *Engineering Drawing and Design*, Fifth Edition, for the following appendices:

- American National Standards of Interest to Designers, Architects, and Drafters
- ASME Standard Line Types
- Dimensioning and Tolerancing Symbols and ASME Dimensioning Rules
- Designation of Welding and Allied Processes by Letters
- Symbols for Pipe Fittings and Valves

### ASME Print Reading or Drawing Exercises



The ASME Print Reading or Drawing Exercises found on the **Student CD** are actual industry drawing files containing **intentional ASME errors**. You can correct the drawing files using CADD or redline prints to conform to accepted



ASME standards. This provides a valuable supplement for learning ASME standards. Searching actual industry drawings in an effort to find errors helps you form a keen eye for correct drafting presentation and compliance with national standards. This activity is the function of a **drafting checker** in industry. A drafting checker is the person who takes a completed drawing from the drafter and evaluates the drawing for proper standards, technical details, and accuracy for product design and dimensioning applications. After checking, the drawing goes back to the drafter for final completion before going to the design engineer for approval and on to manufacturing. The checker often uses red lines to mark drawing errors and required edits on a print or on the CADD file. The drafter then systematically checks off each item as corrections are made to ensure that every item is correctly edited. Possessing this skill allows you to become more familiar with proper ASME standards, correct drawing layout, and proper dimension placement when creating your own drawings and when correcting drawings created by others.

## TO THE STUDENT

*Engineering Drawing and Design* is designed for you. The development and presentation format have been tested in conventional and individualized classroom instruction. The information presented is based on engineering drafting practices and standards, drafting room practice, and trends in the design and drafting industry. This textbook is the only engineering drafting and design reference that you will need. Use the text as a learning tool while in school, and take it along as a desk reference when you enter the profession. The amount of written text is comprehensive but kept as concise as possible. Examples and illustrations are used extensively. Drafting is a graphic language, and most drafting students learn best by observing examples. The following are a few helpful hints to use as you learn engineering drawing and design using this textbook:

1. **Read the text.** The text content is intentionally designed for easy reading. Sure, it does not read the same as an exciting short story, but it does give the facts in a few easy-to-understand words. Do not pass up the reading, because the content helps you understand theory and how to create proper drawings.
2. **Look carefully at the examples.** The figure examples are presented in a manner that is consistent with drafting standards. Look at the examples carefully in an attempt to understand the intent of specific applications. If you are able to understand why something is done a certain way, it is easier for you to apply the concepts to the drawing problems in school and on the job. Drafting is a precise technology based on rules and guidelines. The goal of a drafter is to prepare drawings that are easy to interpret. There are situations when rules must be altered to handle a unique situation. You will have to rely on judgment based on your knowledge of accepted standards. Drafting is often like a puzzle, and there may be more than one way to solve a problem.
3. **Use the text as a reference.** Few drafters know everything about drafting standards, techniques, and concepts, so always be ready to use the reference if you need to verify how a specific application is handled. Become familiar with the definitions and use of technical terms. It is difficult to

memorize everything in this textbook, but after considerable use of the concepts, engineering drafting applications should become second nature.

4. **Learn each concept and skill before you continue to the next.** The text is presented in a logical learning sequence. Each chapter is designed for learning development, and chapters are sequenced so that drafting knowledge grows from one chapter to the next. Problem assignments are presented in the same learning sequence as the chapter content and also reflect progressive levels of difficulty.
5. **Practice.** Development of good drafting skills depends to a large extent on practice. Some individuals have an inherent talent for computer use, and others need more time to master the computer and applications. Most CADD software programs have features that range from easy to use to very complex. It can take several months of continuous use and training to become proficient with the system and function. Additional time and practice is needed to become familiar with company practices and standards when you become employed in the drafting industry.
6. **Use sketches or preliminary drawings.** When you are drawing manually or with a computer, the proper use of a sketch or preliminary drawing can save time in the long run. Prepare a layout sketch or preliminary layout for each problem. This gives you a chance to organize thoughts about drawing scale, view selection, dimension and note placement, and sheet size. After you become a drafting veteran, you may be able to design a sheet layout in your head, but until then use sketches to help you get started.
7. **Use professional equipment and materials.** For the best possible learning results and skill development, use professional equipment and CADD software. Most drafting technology programs in schools have quality professional computers, peripherals, and software. Compare programs and evaluate the facilities and use of current software before starting. CADD software manufacturers revise their software as often as annually. The school program should be using a fairly recent software release to keep pace with industry. In many cases, the technology used in schools exceeds what is used in some companies.

The magnitude of information found in this textbook is enormous. The content is the most comprehensive, innovative, well organized, and accurate found in any discipline-related textbook. More than 1000 drafting problems offer you variety from basics through advanced applications. The authors, general reviewers, technical reviewers, and editors have worked hard to minimize errors, but some errors may still exist. In an effort to help us make this textbook perfect, consider submitting errors that you find. Feel free to also let us know if you have suggestions for improving the next edition. You can submit feedback to:

Delmar Cengage Learning  
 Care of author of Engineering Drawing and Design  
 Executive Woods  
 5 Maxwell Drive

## SUPPLEMENTS

### For Instructors

#### Instructor Resources CD

This educational resource creates a truly electronic classroom. It contains tools and instructional resources that enrich the classroom experience and make preparation time shorter. The elements of the Instructor Resources CD link directly to the text and tie together to provide a unified instructional system. With the Instructor Resources, you can spend time teaching, not time preparing to teach.

Features include the following:

- Syllabus

Syllabi templates created for use in the development of specific courses. You can modify the syllabi templates to match your course format, length, and teaching style.

- Chapter Hints

Objectives and teaching hints provide you with ideas for activities to use when teaching each chapter of this textbook in your courses.

- PowerPoint Presentations

The *Engineering Drawing and Design*, Fifth Edition, PowerPoint presentations are the most comprehensive set available in this discipline. A presentation is available for and corresponds exactly to the content of each chapter in the textbook. The PowerPoint slides provide the basis for a lecture outline that helps the instructor present concepts and material in an effective and visually motivating manner. The presentations are excellent teaching tools that allow the instructor to highlight key points and concepts graphically. Slides aid student retention of textbook material, enhance lecture presentation, help maintain student attention, and support note taking and classroom discussions. The *Engineering Drawing and Design*, Fifth Edition, PowerPoint presentations include:

- Slides that address all major topics in the chapter.
- Concise format that parallels and compliments chapter content.
- Visually pleasing and inspiring slide design and layout.
- Considerable number of illustrations.
- Key terms hyperlinked to glossary slides.

The presentations are offered in PowerPoint 97–2003 presentation format. View the presentations using Microsoft Office PowerPoint Viewer, available as a free download from the Microsoft Download Center. View and edit the presentations using Microsoft Office PowerPoint software. Many key terms throughout each presentation are hyperlinked to glossary slides at the end of the presentation. During a slide show, pick the hyperlinked term to view the corresponding glossary slide. Then pick anywhere on the glossary slide to return to the previous slide. Glossary slides are hidden so they do not appear at the end of the slide show. Some slides include hyperlinks to previous slides within the presentation. Pick the hyperlinked reference to view the corresponding slide. Pick anywhere on the reference slide to return to the previous slide.

- ExamView Computerized Test Bank

More than 800 questions of varying levels of difficulty are provided in true–false, multiple-choice formats, and matching so instructors can assess student comprehension.

- ASME Print Reading or Drawing Exercises

The same ASME Print Reading or Drawing Exercises found on the **Student CD** are also located on the Instructor Resource CD with accompanying solution drawings.

- Animation Resources

These AVI files graphically show the execution of key concepts and commands in drafting, design, and AutoCAD and let instructors bring multimedia presentations into the classroom.

- Image Library

A database of all the images from the text that can be used for enhancing lecture presentations.

### Solutions Manual

A solutions manual is available with answers to end-of-chapter test questions and solutions to end-of-chapter problems. Solutions are also provided for the workbook problems.

### CourseMate

CourseMate for *Engineering Drawing and Design*, Fifth Edition, offers students and instructors access to important tools and resources, all in an online environment. The CourseMate includes an Interactive eBook for *Engineering Drawing and Design*, Fifth Edition, video clips, interactive quizzes, flashcards, and interactive glossary, and an Engagement Tracker tool for monitoring student's progress in the CourseMate product.

### WebTutor Advantage

Newly available for *Engineering Drawing and Design* is Web Tutor Advantage for the Blackboard online course-management system. The WebTutor includes chapter presentations in PowerPoint, end-of-chapter review questions, tests, discussion springboard topics, and more, all designed to enhance the classroom experience.

### For the Student

#### Workbook

Although hundreds of problems are found throughout the core textbook, a workbook (ISBN 1-1113-0958-2) is developed to correlate with *Engineering Drawing and Design*, Fifth Edition. This workbook follows the main text and contains “survival information” related to the topics covered. The problem assignments take you from the basics of line and lettering techniques to drawing projects. Problems can be done on CADD or manually.

# ACKNOWLEDGMENTS

The following is dedicated to all professionals and companies that participated in making the Fifth Edition of *Engineering Drawing and Design* the best textbook available in this discipline.

## Cover

ATV Illustration © courtesy Jim Hatch, [www.hatchillustration.com](http://www.hatchillustration.com), Client: Honda, Ad Agency: Vreeke and Associates.

Jim Hatch graduated from Otis/Parsons School of Design in Los Angeles with a bachelor of fine arts degree and immediately began an intense apprenticeship and job with his mentor and leading technical illustrator, Kevin Hulsey. Jim then joined the team that conceptualized and built the Petersen Automotive Museum in Los Angeles, California. He held the position of Founding Exhibit Designer and Art Director for more than six years. Jim then moved to Santa Barbara, California, and opened the Hatch Illustration Studio, which caters to clients who require high-quality renderings of mechanical and technological subject matter. Jim created technical illustrations for a wide array of companies from Infiniti to Orbital Rocket launch systems with a focus on the motorcycle industry, including Honda, Cycle World, Yamaha, Buell, Dunlop, and ICON riding gear. He has also created posters for the famous Monterey Historic Races, commemorative art for the In-N-Out hamburger chain, and the Petersen Automotive Museum.

The ATV Illustration cover image was created for client Vreeke and Associates ad agency for the Honda publication *Red Rider*. The line work was created using Paths in Photoshop and stroking with a rough paintbrush setting to emulate a hand-inked experience.

From the Author: The ATV Illustration © cover image demonstrates the content of *Engineering Drawing and Design* by representing the concept of taking a product evolution from idea through design and drafting, into manufacturing and to the final product. *David A. Madsen*

## General Reviews

The following people provided general reviews and comments for the improvement of this textbook:

Jack Johnson, Elizabethtown Community College  
Marguerite Newton, Niagara County Community College

Margaret Robertson, Lane Community College  
Dennis Schwartz, Wright Medical Technology, Inc.  
Wayne T. Welander, ITT Technical Institute  
Tony Whitus, Tennessee Technology Center

## Comprehensive Technical Reviews and Significant Contribution

A special acknowledgement is given to the following professionals who provided comprehensive technical reviews of chapters throughout this textbook and extensive support with content, applications, drawings, photographs, and illustrations. The list is in alphabetical order. Technical reviews involve:

- Editing outdated content with revised and new current technology, including new and better drawing and illustrative figures.
- Writing new content for the Engineering Design Applications based on actual industry experience.
- Developing and illustrating new CADD Applications.
- Creating new Professional Perspectives based on real-world experience, advice, words of wisdom, and specific content about the discipline.
- Providing new actual industry problems.
- Creating new Green Technology Applications features.

### Brad Dotson, B&D Consulting ([www.sheetmetaldetailing.com](http://www.sheetmetaldetailing.com))

Brad Dotson provided extensive review and support for the revision of this HVAC and pattern development. Brad is the owner of B&D Consulting, in Dietrich, Idaho. B&D Consulting specializes in 3-D imaging and detailing of shop drawings and production drawings for the HVAC sheet metal industry. Brad has more than 32 years experience in drafting, detailing, estimating, project management, and general management in the HVAC industry, with more than 20 years experience in 3-D CAD/CAM applications. Brad is an owner-member in the Sheet Metal Worker's International Association.

**Cristofer Morley and Tom Hawley,  
O'Neil & Associates, Inc.  
(www.oneil.com)**

Initiated by Tom Hawley, Cristofer Morley provided an extensive review and many new figures for the pictorial drawing and technical illustration chapter. Cristofer is manager of graphics technology at O'Neil & Associates, Inc. He has 25 years experience in the aerospace and special equipment industry supplying illustrated parts and installation manuals for corporate aircraft and consumer robotic equipment as well as working closely with the Federal Aviation Administration for custom avionics system install manuals. He is a licensed aircraft mechanic that specialized in custom avionics and airframe installations and modifications. He headed up the special machinery installation manual division at a major PET bottle manufacturing company. As manager of graphics technology at O'Neils, Cristofer also heads up the e-Learning, 3-D, animation group, which creates online learning courses for commercial and military markets.

Tom Hawley coordinates sales activities and advertising and marketing for O'Neil & Associates. Tom has 35 years experience supporting heavy industrial, aerospace, and automotive products, with the bulk of his career focused on military programs. His career path has ranged from an entry-level illustrator to the marketing, sale, and management of multimillion dollar electronic and Web-based publishing and training systems. He has worked in agencies and in publications departments within Fortune 500 companies. Tom taught technical illustration and architectural rendering for six years at Sinclair College in Dayton, Ohio.

O'Neil & Associates, Inc., founded in 1947, is a global leader in the development of product support documentation. Serving clients in the defense, aerospace, automotive, heavy equipment, and appliance industries, O'Neil manages and distributes product support information via the Internet, CD-ROM, paper, and e-learning environments. Producing clear, concise, and cost-effective technical graphics has always been a priority for O'Neil, and the company continuously pursues the latest illustration tools and techniques. O'Neil has more than 380 employees, with 275 at the company's Dayton, Ohio, headquarters, and the rest around the country near key customer locations.

**David Cvengros, Synerject North  
America (www.synerject.com)**

David E. Cvengros provided extensive technical support for the revision of this textbook using the guidelines of design and drafting principles established by ASME. David is the supervisor of the engineering design services department at Synerject North America headquartered in Newport News, Virginia. He reports directly to the engineering manager, James A. Kimmel. Synerject is a global provider of engine management solutions for the scooter and recreational vehicle market worldwide and has locations on three continents with more than 200 employees.

David is responsible for the quality and integrity of all drawings, CAD models, and data management within the Newport News headquarters. David also manages design engineering principles throughout the Synerject global engineering base.

David has more than 29 years of experience in metal fabrication, welding and brazing, mechanical design, and the skilled trade of drafting. He has worked for Ford Motor Company, Eaton Corporation, and, most notably, Synerject. David is an

American Design Drafting Certified Mechanical Drafter and a member of the American Design Drafting Association (ADDA) board of directors. David is a member of the Thomas Nelson Community College (Newport News, Virginia) CAD board of advisors. David is retired from the U.S. Navy for which he honorably served on both active and reserve duty. Additional thanks to John Walters, BSME Synerject Principal Engineer, Synerject North America, Newport News, Virginia, for a CADD application based on assigning different material to a solid part model to explore design performance under load. A special thanks is also given to the following for their insight into rapid prototyping:

Dave Kilgore, vice president and general manager,  
Synerject Global

Jamie Kimmel, engineering manager, Synerject  
North America

Todd Answine, manager, Business Development and Fuel  
Components Architecture, Synerject North America

**Dennis Alan Schwartz, Wright Medical  
Technology, Inc. (www.wmt.com)**

Dennis Alan Schwartz provided extensive review and support for the revision of this textbook using the ASME Y14.5-2009 standard and the technical review of many chapters in this textbook. Dennis is the director of engineering services at Wright Medical Technology, Inc., in Arlington, Tennessee. Wright is a global manufacturer and distributor of orthopedic products. Dennis is responsible for all U.S. engineering drawings and CAD models and manages engineering changes required on drawings. Dennis has more than 35 years of mechanical design and drafting experience. Dennis is an ADDA-certified drafter and an American Society of Mechanical Engineers (ASME) certified senior level GD&T professional. He is a member of the ADDA board of directors.

**Olen K. Parker, Executive Director  
and Corporate Operations Officer,  
ADDA International (www.adda.org)**

Olen worked for one of the top 500 engineering and construction firms in the United States for 23 years, starting as a tracer duplicating details and sections to drawings. Olen was a professional drafter, detailer, chief drafter, and graphic arts director. He was appointed to the ADDA board of directors, appointed chair of several committees, and was elected secretary, vice president, and president. Olen is the executive director and corporate operations officer for the ADDA and ADDA International. The ADDA staff, board of directors, and governors assist thousands of students and professionals reach new goals in their career every year. Olen's vision is simple: If he can make one person have a better life by helping his or her career or designing a better product or home, then he has succeeded.

**Pau Guarro, Francesc Civit, and  
Marc Fernández, Solid Enginyeria  
(www.solid-enginyeria.com)**

Paralleling the general design process information in Chapter 25 is the examination of a case study on a new product

design from concept through production. The product used for this design sequence example is the Solid Enginyeria's PT-005 Roof Solar Tracker®. Solid Enginyeria Ltd. is dedicated to designing, prototyping, and testing positioning and power transmission mechanisms. Created in 1999 and based in Barcelona, Spain, Solid Enginyeria's main objective is to provide integral engineering services to a wide range of industries.

The product used for this design sequence example is Solid Enginyeria's Roof Solar Tracker. Special thanks is given here to Francesc Civit, senior design engineer; Marc Fernández, design engineer; and Pau Guarro, mechanical engineer with Solid Enginyeria; and their colleagues who supported this content.

### **PROCAD Software ([www.procad.com](http://www.procad.com))**

A PROCAD senior technical representative performed an extensive review and support for the revision of industrial pipe drafting content. PROCAD Software is located in Calgary, Alberta Canada. It has been offering process piping CAD applications since 1992. With 2D and 3D versions, PROCAD allows companies of all sizes and different industries to save time and money with their product offering. PROCAD's products include 2D DESIGNER and 3DSMART, which work as add-ons to AutoCAD software. PapriCAD, PROCAD's latest software offering for piping and electrical design is a complete solution by including its own CAD engine making it suitable for companies that do not have AutoCAD.

### **Terry Schultz, Chairman of the ADDA Executive Committee ([www.adda.org](http://www.adda.org))**

Terry Schultz provided an extensive review and support for the revision of the HVAC and structural chapters in this textbook. Terry is the chairman of the ADDA executive committee as well as past president of the ADDA. The ADDA is the only international, not-for-profit, professional membership and educational association that supports drafters and designers of all disciplines, technical illustrators, and graphic illustrators. Terry is responsible for directing the executive committee in the daily overview of the operation of the association. Terry has more than 20 years experience working with all disciplines, but his emphasis has been in the mechanical, electrical, and plumbing (MEP) and structural, usually in conjunction with architectural and commercial projects. Terry is an ADDA-certified mechanical drafter.

### **Zane Pucylowski and Shane Saunders, Phoenix Engineering and Consulting, Inc. ([www.phoenixengineering.com](http://www.phoenixengineering.com))**

Initiated by Zane Pucylowski, president of Phoenix Engineering and Consulting, Inc., Shane Saunders, engineering technician, participated in the technical review, providing information, creating copy, and preparing drawings for several chapters throughout this textbook. Phoenix provides professional engineering, general consulting, design, analysis, and evaluation services to solve a wide range of problems.

## **Contributors**

The quality of this text is enhanced by the support and contributions from industry. The list of contributors is extensive, and acknowledgment is given at each figure illustration. The

following individuals and their companies gave an extraordinary amount of support toward the development of new content and illustrations for this edition.

### **Aerohydro, Inc. ([www.aerohydro.com](http://www.aerohydro.com))**

Robert Page, application engineer, provided a surface model image courtesy of Werner Yacht Design and a surface model image courtesy of Reinhard Siegel used in the CADD chapter.

### **AntWorks Engineering Pty. Ltd. ([www.antworks.com.au](http://www.antworks.com.au))**

Anthony Murphy provided content information, a stress analysis animation for the CADD chapter, and a 3-D model for the piping chapter.

### **Autodesk, Inc. ([www.autodesk.com](http://www.autodesk.com))**

Special thanks is given to the following professionals from Autodesk, Inc., who provided technical support and figures for the new edition.

Adam Menter, sustainable design program, provided information and illustrations and coordinated the Green Technology Application in the CADD chapter.

Ed Martin, senior industry manager for Automotive & Transportation industries provided CADD consultation and helped secure images from Autodesk. Ed also provided content for a CADD Application.

Jun Shim, senior product marketing manager for Autodesk Seek, provided content and information for CADD Applications.

Catherine Palmer, marketing manager, AEC Initiatives, provided content and information for a CADD Application.

Phil Dollan, Autodesk Inventor learning expert, provided illustrations for the Green Technology Application in the CADD chapter.

Sarah Hodges coordinated the original discussion and helped coordinate contact with the Autodesk team of participants.

### **Alan Mascord Design Associates, Inc. ([www.mascord.com](http://www.mascord.com))**

Jon Epley for professional support in providing content, photographs, drawings, and illustrations.

### **Kubotek USA ([www.kubotekusa.com](http://www.kubotekusa.com))**

John Reis, product manager, provided images used in the CADD chapter.

### **Proto Labs, Inc. ([www.protolabs.com](http://www.protolabs.com))**

Special thanks to Bradley A. Cleveland, president and CEO, and Stacy Sullivan, media manager, for prototyping content and graphics related to rapid injection molding and subtractive rapid prototyping.

### **Parametric Technology Corporation ([www.ptc.com](http://www.ptc.com))**

Michael M. Campbell, senior vice president, product development, Arbortext Business Unit, provided images and animations

for use in several chapters. François Lamy, vice president, product management, Windchill Products Group, provided CAD and CAM/CAM images.

### Southwest Windpower ([www.windenergy.com](http://www.windenergy.com))

Thanks to Michael French, graphics coordinator for Southwest Windpower, who provided the content, photographs, and illustrations for a Green Technology Application feature.

### 3-D.DZYN

Special thanks to Ron Palma, 3-D.DZYN, for his friendship and for providing loyal feedback related to professional CADD applications.

### TriMech™ ([www.trimech.com](http://www.trimech.com))

Kelly Judson, engineering manager, for support with rapid prototyping content.

### 2-Kool, Inc. Runabout ([www.runabouts.net](http://www.runabouts.net))

Roger M. Berg, manager, provided drawings and models and content for an animation from a product.

### Utility Scale Solar, Inc. ([www.utilityscalesolar.com](http://www.utilityscalesolar.com))

Jonathan Blitz, CTO, provided images and content review for the product described used in the Green Technology Application in the CADD chapter.

### Water Pik, Inc. ([www.waterpik.com](http://www.waterpik.com))

Tim Hanson, model shop supervisor, helped update and provided new images for a CADD Application in the CADD chapter.

## Architectural Drafting and Design

Many figures appearing in Chapters 22 and 23 were reprinted from Jefferis, and Madsen, *Architectural Drafting and Design*, fifth and sixth editions, published by Cengage Delmar Learning.

## From the Author

Professionally speaking, design drafting is my life! I was forever hooked after my first high school drafting experience. My education includes a bachelor of science degree and master of education degree from Oregon State University with a focus on anything related to drafting. I have many years of practical experience in industry as a design drafter in a wide variety of technical disciplines. I have also owned my own architectural design and construction business.

My academic career started with my first teaching job at Centennial High School in Gresham, Oregon. After three years, and with the help of my great friend and mentor, Lee Turpin, I seized the opportunity to join Clackamas Community College.

I retired as department chair in 2001 after more than 30 years of teaching. During my tenure, I was proud to be a member of the ADDA and its board of directors. The special honor of director emeritus was granted to me by the ADDA in 2005. My first publishing experience came in 1976 with *Geometric Dimensioning and Tolerancing*. Titles authored in architectural, civil engineering, and an AutoCAD series followed. I am proud that my son, David P., has also chosen to be a drafting designer, educator and textbook author. I love my farm, fishing, hunting, Oregon, and Hawaii. I give special thanks to my wife, Judy, for her patience and support during the intense revision of this textbook.

To students and educators using *Engineering Drawing and Design*, Fifth Edition:

I have tried very hard to make this edition the best ever and for it to be the best book available for teaching and learning drafting and design. The communication style is intended to help make learning engineering drawing and design as interesting as possible. Numerous illustrations are included in an effort to keep reading to a minimum and to accurately demonstrate proper standards. Actual industry applications are a key element so you can relate the learning content with real-world use. Although every effort has been made to comply with national standards, and eliminate errors, some may have been missed due to the magnitude of content found in this textbook. In an effort to make future improvements, please notify the publisher of any errors or missing content.

Sincerely,

David A. Madsen

## ABOUT THE AUTHORS

### David A. Madsen



**MADSEN DESIGNS INC.**

David A. Madsen is the president of Madsen Designs Inc. ([www.madsendesigns.com](http://www.madsendesigns.com)).

David is Faculty Emeritus of Drafting Technology and the Autodesk Premier Training Center at Clackamas Community College in Oregon City, Oregon. David was an instructor and department Chairperson at Clackamas Community College for nearly 30 years. In addition to community college experience, David was a Drafting Technology instructor at Centennial High School in Gresham, Oregon. David is a former member of the American Design and Drafting Association (ADDA) Board of Directors, and was honored by the ADDA with Director Emeritus status at the annual conference in 2005. David is an Autodesk Authorized Author. David has extensive experience in mechanical drafting, architectural design and drafting, and building construction. David holds a Master of Education degree in Vocational Administration and a Bachelor of Science degree in Industrial Education. David is the author of *Engineering Drawing and Design*, *Geometric Dimensioning and Tolerancing*, *Print Reading for Engineering and Manufacturing Technology*, and coauthor of *Architectural AutoCAD*, *Architectural Desktop*

and its Applications, Architectural Drafting and Design, Architectural Drafting Using AutoCAD, AutoCAD and Its Applications: Basics, Advanced, and Comprehensive, AutoCAD Architecture and Its Applications, AutoCAD Essentials, Civil Drafting Technology, and Print Reading for Architecture and Construction Technology.

## David P. Madsen

---

### ENGINEERING DRAFTING & DESIGN, INC.

*Drafting, design, and training for all disciplines.*

*Integrity - Quality - Style*

David P. Madsen is the president of Engineering Drafting & Design, Inc. and the vice president of Madsen Designs Inc. ([www.madsendesigns.com](http://www.madsendesigns.com)). Dave provides drafting and design consultation and training for all disciplines. Dave is an Autodesk Authorized Author, and a SolidWorks Research Associate. Dave has been a professional design drafter since 1996, and has extensive experience in a variety of drafting, design, and engineering disciplines. Dave has provided drafting and computer-aided design and drafting instruction to secondary and postsecondary learners since 1999, and has considerable curriculum, and program coordination and development experience. Dave holds a

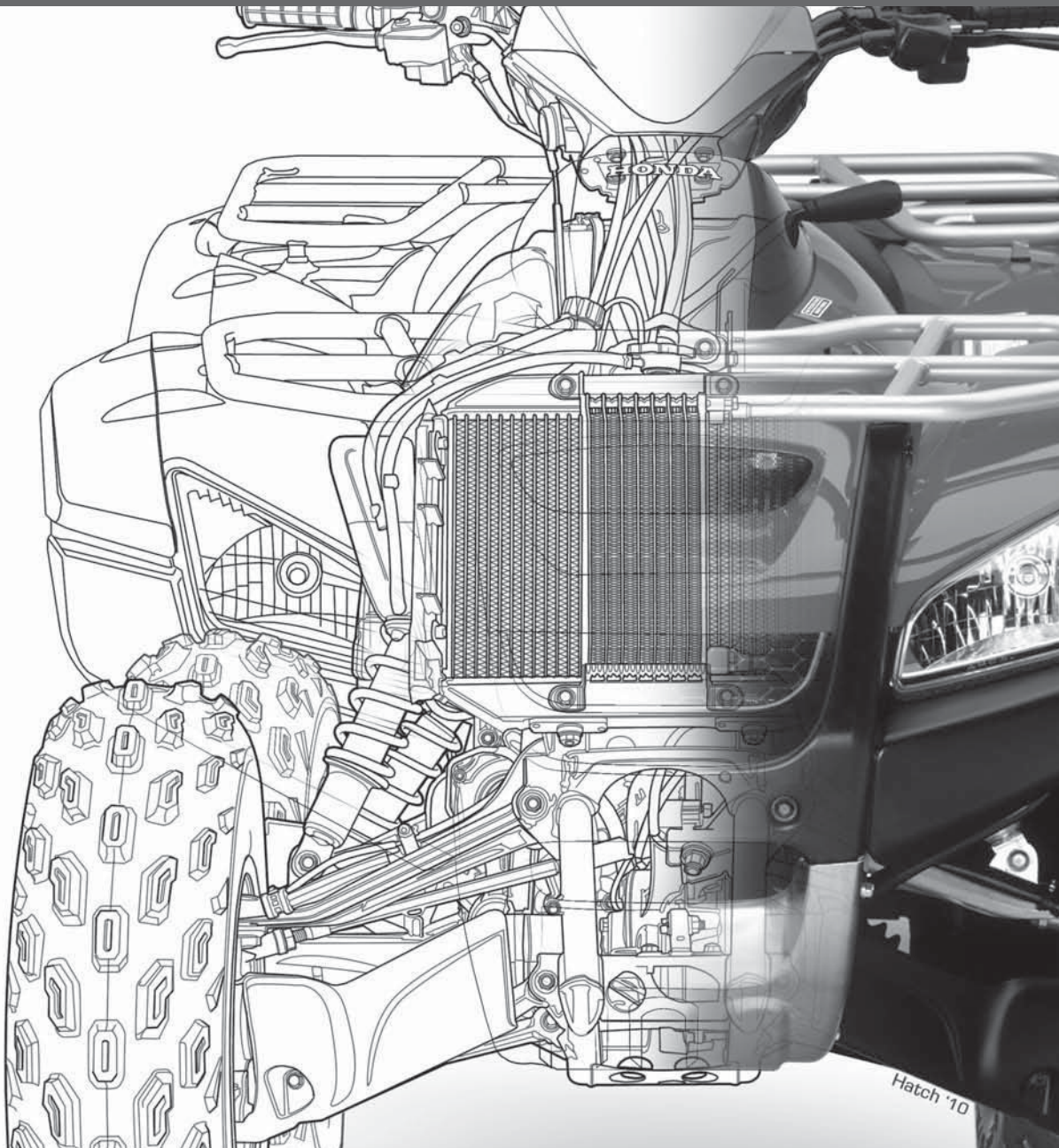
Master of Science degree in Educational Policy, Foundations, and Administrative Studies with a specialization in Postsecondary, Adult, and Continuing Education; a Bachelor of Science degree in Technology Education; and an Associate of Science degree in General Studies and Drafting Technology. Dave is the author of *Inventor and its Applications*, and coauthor of *Architectural Drafting and Design*, *Architectural Drafting Using AutoCAD*, *AutoCAD and Its Applications: Basics and Comprehensive*, *Civil Drafting Technology*, *Engineering Drawing and Design*, *Geometric Dimensioning and Tolerancing*, *Print Reading for Architecture and Construction Technology*, and *Print Reading for Engineering and Manufacturing Technology*.

## J. Lee Turpin (author of Student CD Descriptive Geometry Reference Material)

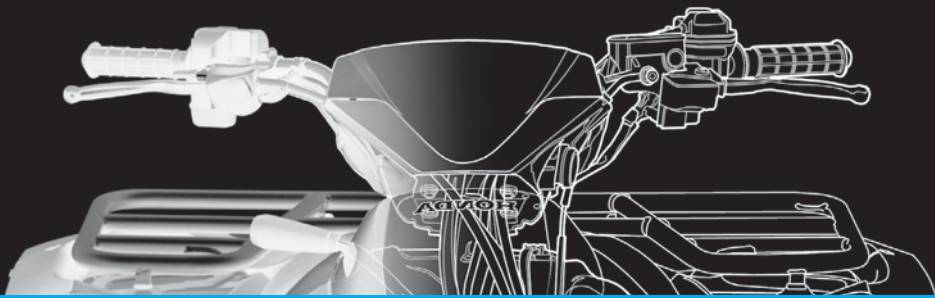
---

J. Lee Turpin is a former Drafting Technology Instructor, Department Chair, and Vocational Counselor at Clackamas Community College in Oregon City, Oregon. Lee worked in industry as a drafter for several years. He has also provided drafting instruction to secondary and posts secondary learners, and in private industry since 1966. Lee holds a Bachelor of Science degree in Industrial Arts and a Master of Science degree in Counseling and Industrial Education.

# Introduction to Engineering Drawing and Design







# CHAPTER

# 1

## Introduction to Engineering Drawing and Design

### LEARNING OBJECTIVES

After completing this chapter, you will:

- Explain topics related to the history of engineering drafting.
- Define drafter and other related terminology.
- Identify categories and disciplines related to drafting.
- Describe the requirements for becoming a drafter.
- List and explain points to consider when seeking employment.
- Identify the professional organization that is dedicated to the advancement of design and drafting.
- Explain workplace ethics and related issues.
- Identify topics related to copyrights, patents, and trademarks.

## THE ENGINEERING DESIGN APPLICATION

Engineering drawing and design is a broad subject that includes a wide range of theory and practice. Many different forms of drawing exist. Drawing occurs while at the lunch table as a basic sketch of a new product idea drawn on a napkin. Drawing also occurs in the form of a series of very complex models for a new automotive design and as hundreds of formal drawings needed for the construction of a skyscraper. You will learn the purpose and requirements to create meaningful engineering drawings as you use this textbook to study engineering drawing and design.

Each chapter in this textbook begins with a special feature titled *The Engineering Design Application*. Each engineering design application provides an introductory topic or study relating the engineering drawing and design process to chapter content. Engineering design applications offer early explanation and systematic problem-solving techniques applied to specific engineering projects or general design and drafting concepts. The engineering design application in this chapter guides you through a basic example of an engineering design process, beginning with an idea and a basic sketch and ending with the manufacture of an actual product.

### From an Idea to a Product

Design ideas and engineering projects often establish or occur in informal settings. For instance, the engineer of a hand-tool manufacturing company was using a typical adjustable wrench to complete a common home-repair task. While using the wrench, the engineer discovered that it was difficult to access a confined location to remove a nut on a piece of equipment. The engineer imagined how the company could design, manufacture, and market a new wrench with features that help make the tool usable in cramped locations. The next day, the engineer and a colleague from the drafting department met for coffee. The engineer sketched the idea for the new wrench on a napkin to communicate the design to the drafter. The sketch in Figure 1.1 shows the idea of taking the existing tool design and creating a new handle with an *ogee*, or S-shaped curve design.

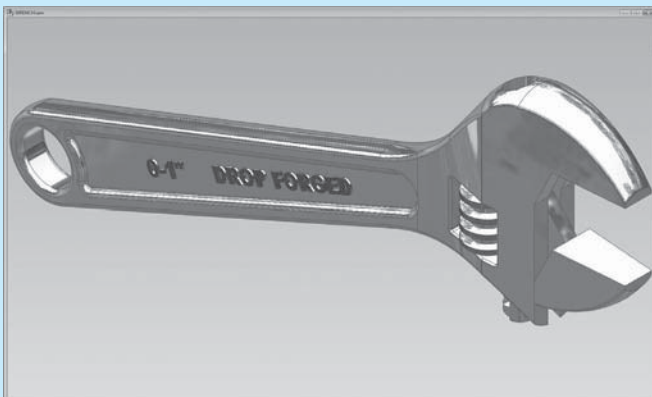
Later the same day, the drafter opens the three-dimensional (3-D) solid model files of the existing wrench design on the computer-aided design and drafting (CADD) system (see Figure 1.2a). The drafter copies and then revises the existing design according to the



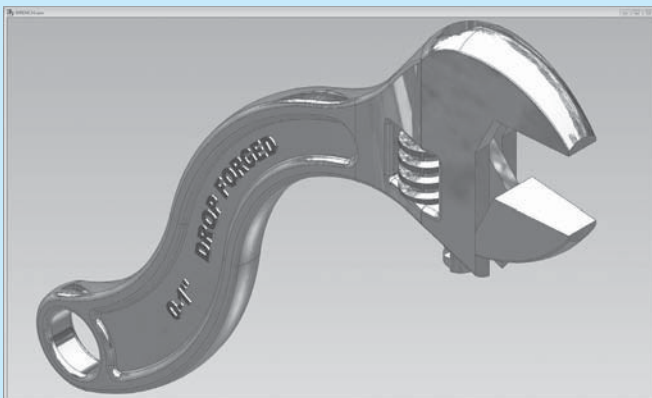
**FIGURE 1.1** An engineer sketching a design idea on a napkin. The sketch communicates the idea of taking an existing tool and creating a new handle with an *ogee*, or S-shaped curve design. © Cengage Learning 2012



**FIGURE 1.3** A rapid prototype of the new product design. © Cengage Learning 2012



(a)



(b)

**FIGURE 1.2** (a) The drafter opens the three-dimensional (3-D) solid model files of the existing wrench design on the computer-aided design and drafting (CADD) system. (b) The drafter revises the existing tool design according to the engineer's sketch shown in Figure 1.1. © Cengage Learning 2012

engineer's sketch (see Figure 1.2b). The drafter presents the new model to the engineer, who is pleased with the results and requests a rapid prototype. **Rapid prototyping (RP)** is the process of creating a physical and functional model from a computer-generated 3-D model, using a RP machine, also known as a **3-D printer**. RP machines are available that build prototypes from various materials such as paper and liquid polymer. The hand-tool company does not have a RP machine, so the drafter sends files of the design to a company that specializes in RP. The drafter and engineer receive a prototype two days later. Figure 1.3 shows the prototype of the new wrench design. The design team tests the prototype in an application similar to what the engineer experienced at home. The prototype worked as expected.

By the next afternoon, the drafter completes the set of working drawings shown in Figure 1.4 and sends the drawings to the manufacturing department to manufacture and assemble the new product. The manufacturing department needs **lead time** to design and make the **forging** dies required to reproduce the parts. Lead time is the time interval between the initiation and the completion of a production process. Forging is the process of shaping malleable metals by hammering or pressing between dies that duplicate the desired shape. The hand-tool company is small, so the drafter is also responsible for creating catalog art and copy for marketing the product (see Figure 1.5). Less than two months after the engineer had the initial idea, the first production run of new wrenches is ready to sell. Figure 1.6 shows the finished product.

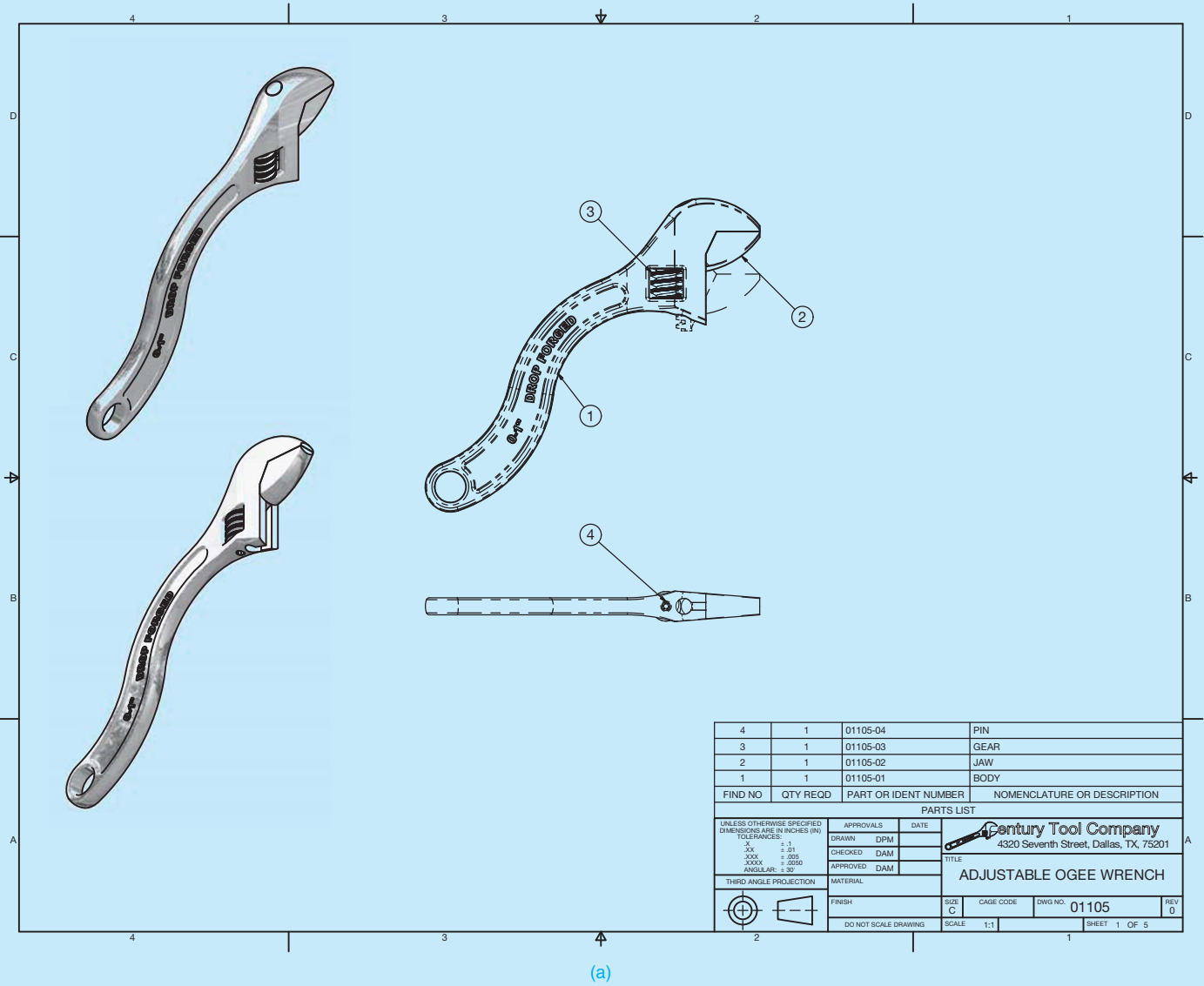


FIGURE 1.4 A set of working drawings for the new wrench design. (a) Assembly drawing and parts list. (b) Detail drawing of the new wrench BODY part. (c) Detail drawing of the new wrench JAW part. (d) Detail drawing of the new wrench GEAR part. (e) Detail drawing of the new wrench PIN part.

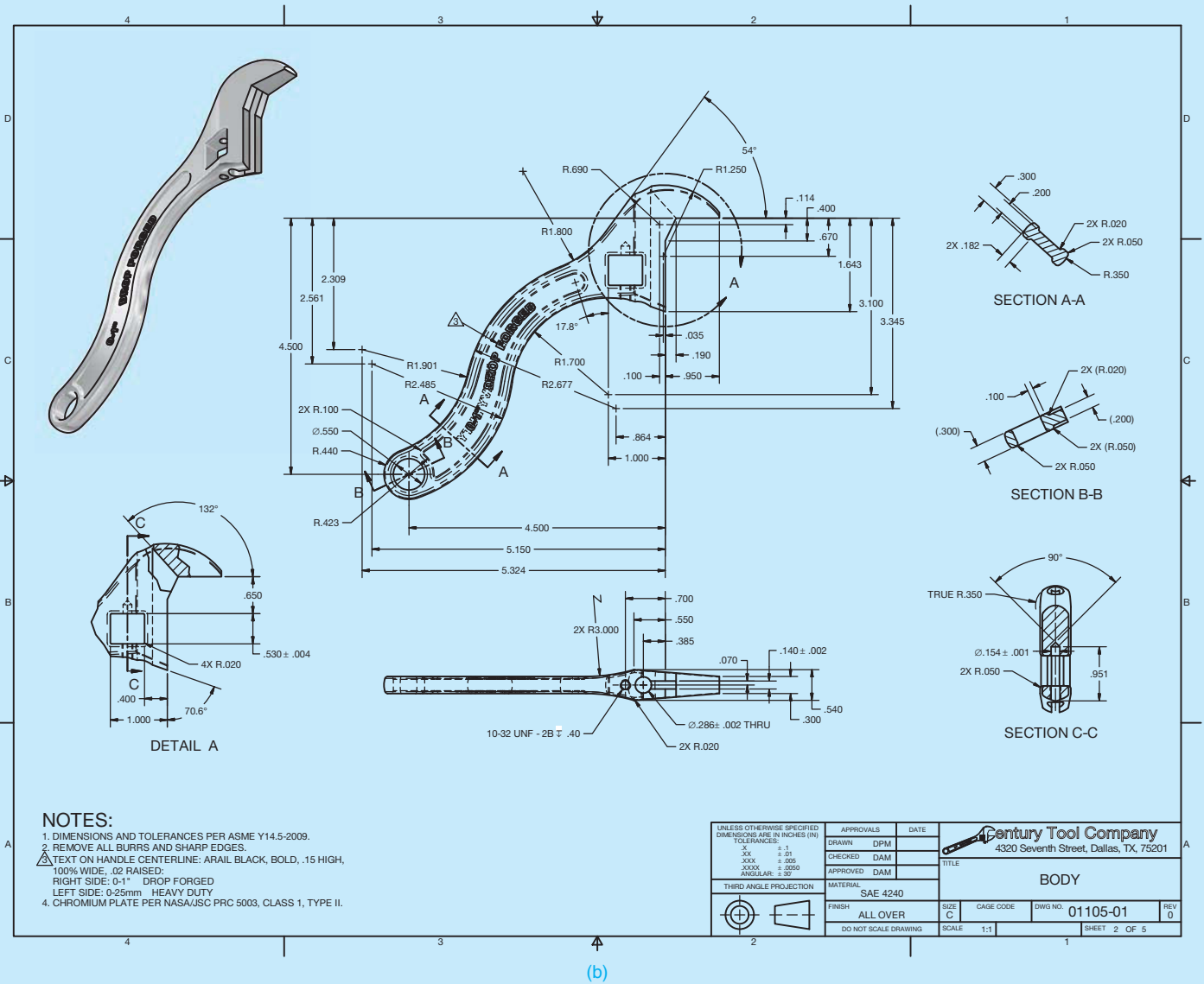


FIGURE 1.4 (Continued)

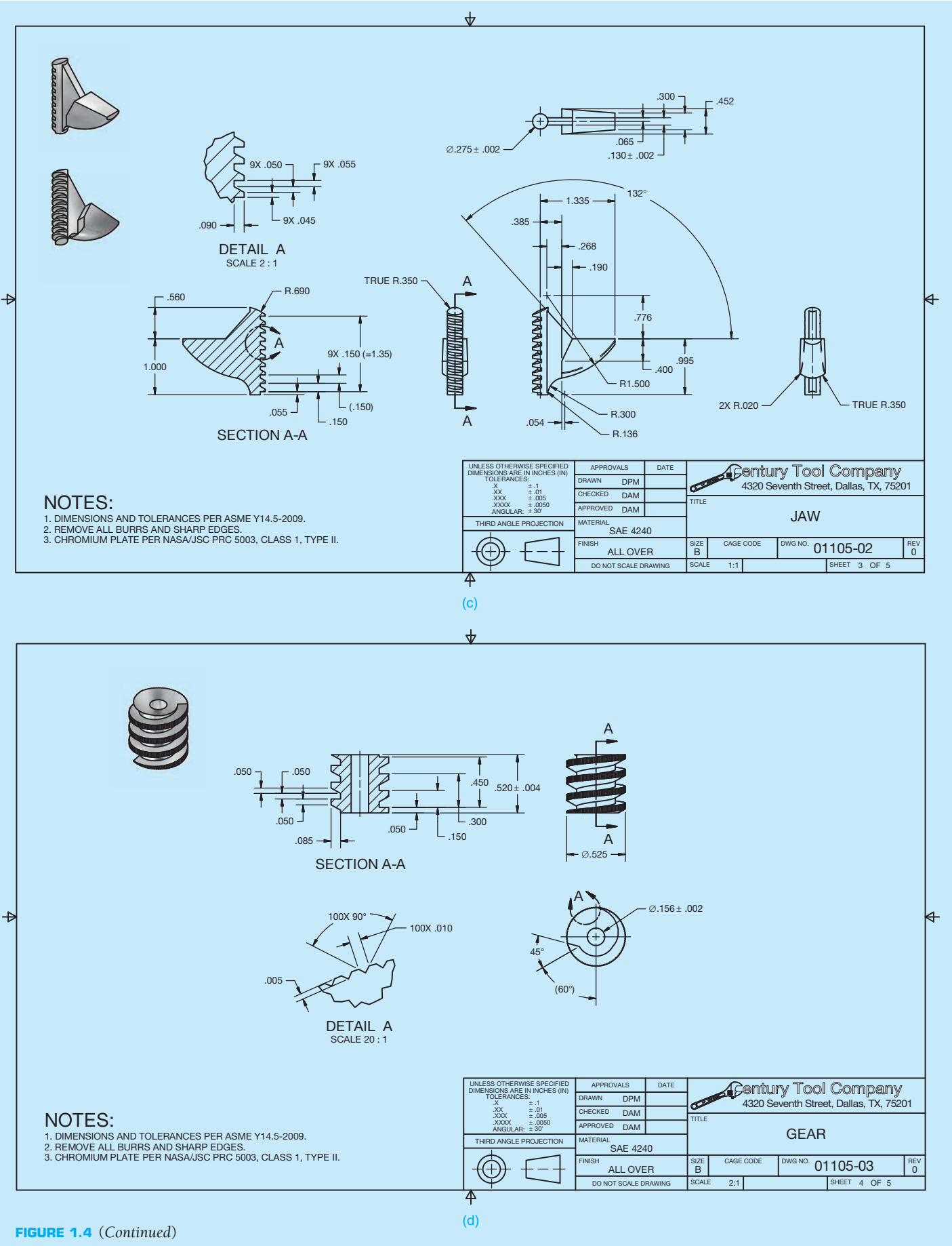
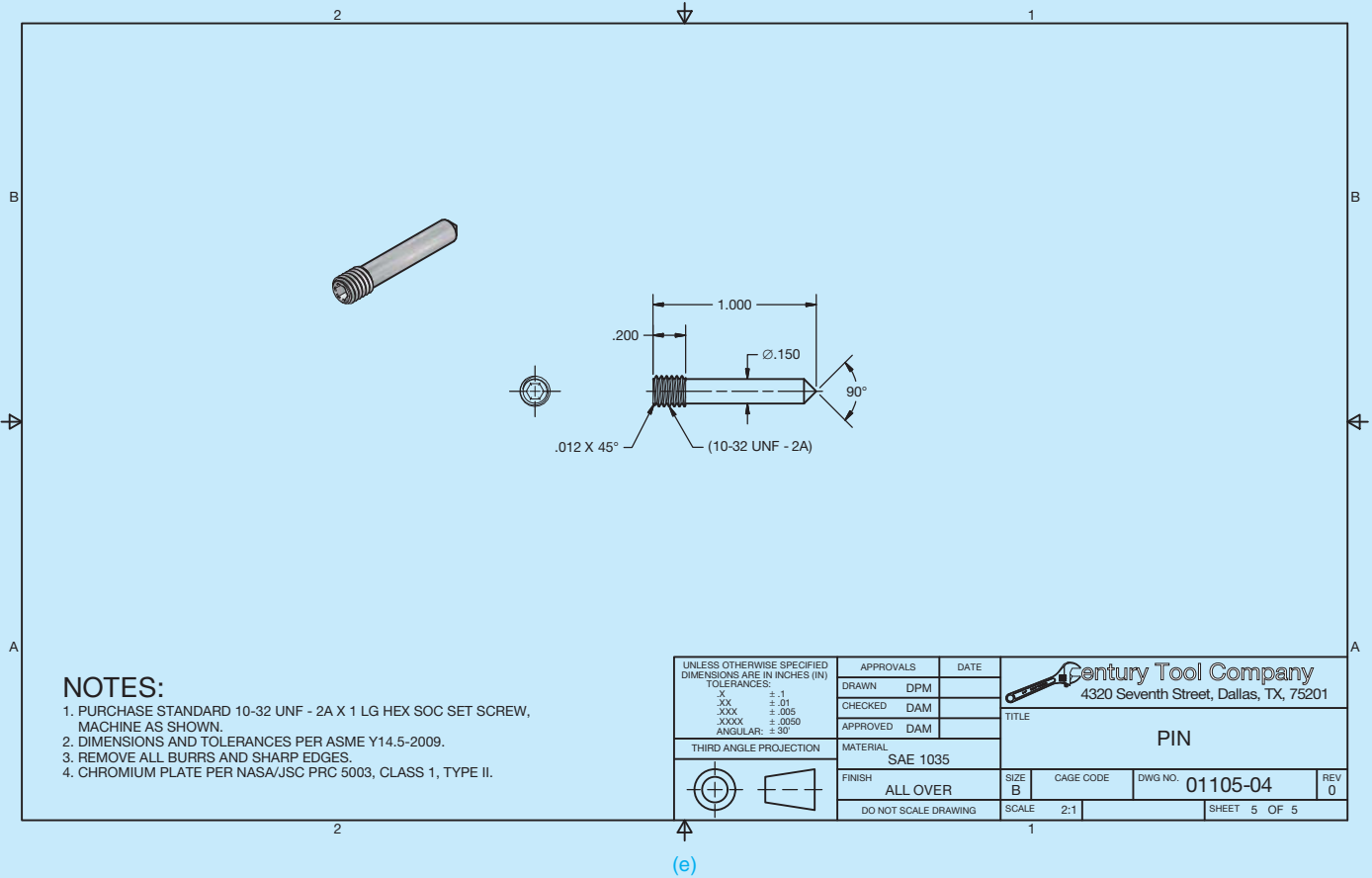


FIGURE 1.4 (Continued)



© Century Tool Company

FIGURE 1.4 (Concluded)

**NEW! ADJUSTABLE WRENCH**

New from Century Tool Company!  
Adjustable wrench with ergonomic S-shaped handle. Access tight places. Reduce fatigue. Get the job done. Quality DROP FORGED steel construction and CHROME finish for generations of use.

Adjustment: 0-1" (0-25mm)  
Catalogue number: 01105  
Price: \$19.95

HEAVY DUTY  
DROP FORGED  
CHROME FINISH

Century Tool Company  
4320 Seventh Street, Dallas, TX, 75201



© Cengage Learning 2012

FIGURE 1.5 The drafter in this small company is responsible for creating catalog art and copy for marketing the new product. © Century Tool Company

FIGURE 1.6 The new wrench design in a finished product, ready to sell.

## INTRODUCTION

**Engineering drawing** is the common language of engineering and describes the process of creating drawings for any engineering or architectural application. Engineering drawings, produced according to accepted standards and format, provide an effective and efficient way to communicate specific information about design intent. Engineering drawings are typically not open to interpretation like other drawings, such as decorative drawings and artistic paintings. A successful engineering drawing describes a specific item in a way that the viewer of the drawing understands completely and without misinterpretation.

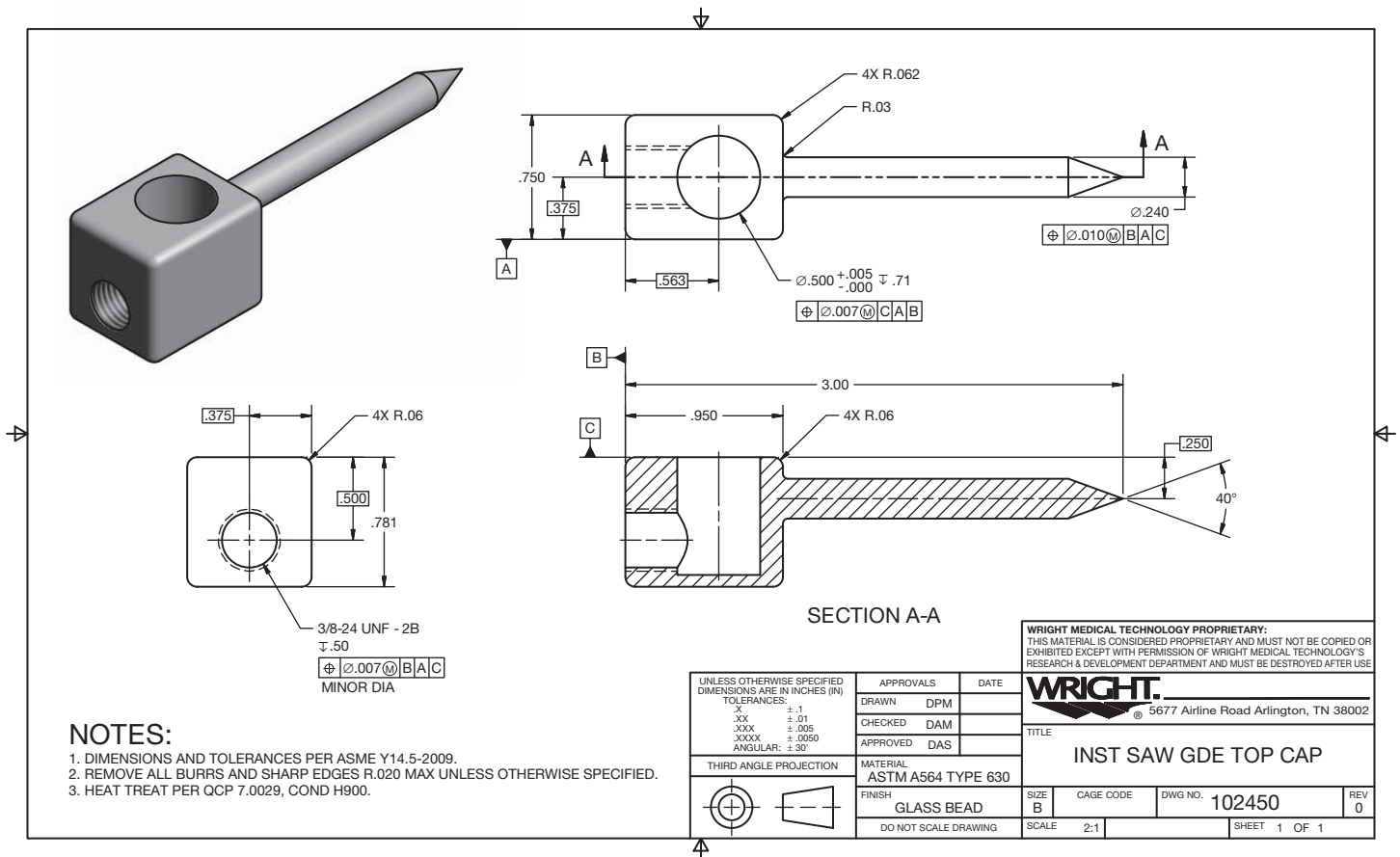
The term *engineering drawing* is also known as **drafting**, **engineering drafting**, **mechanical drawing**, **mechanical drafting**, **technical drawing**, and **technical drafting**. **Drafting** is a graphic language using lines, symbols, and notes to describe objects for manufacture or construction. Most technical disciplines use drafting, including architecture, civil and electrical engineering, electronics, piping, manufacturing, and structural engineering. The term **mechanical drafting** has alternate meanings. The manufacturing industry uses *mechanical drafting*, with its name derived from mechanisms. The construction industry also uses *mechanical drafting*, but the term refers to drafting heating, ventilating, and air-conditioning (HVAC) systems, which is the mechanical portion of an architectural

project. You will learn about drafting common to other disciplines later in this chapter. **Manual drafting** is a term that describes traditional drafting practice using pencil or ink on a medium such as paper or polyester film, with the support of drafting instruments and equipment. **Computer-aided drafting (CAD)** has taken the place of manual drafting. CAD uses computers for drafting. CAD also refers to **computer-aided design** when computers are used to design.

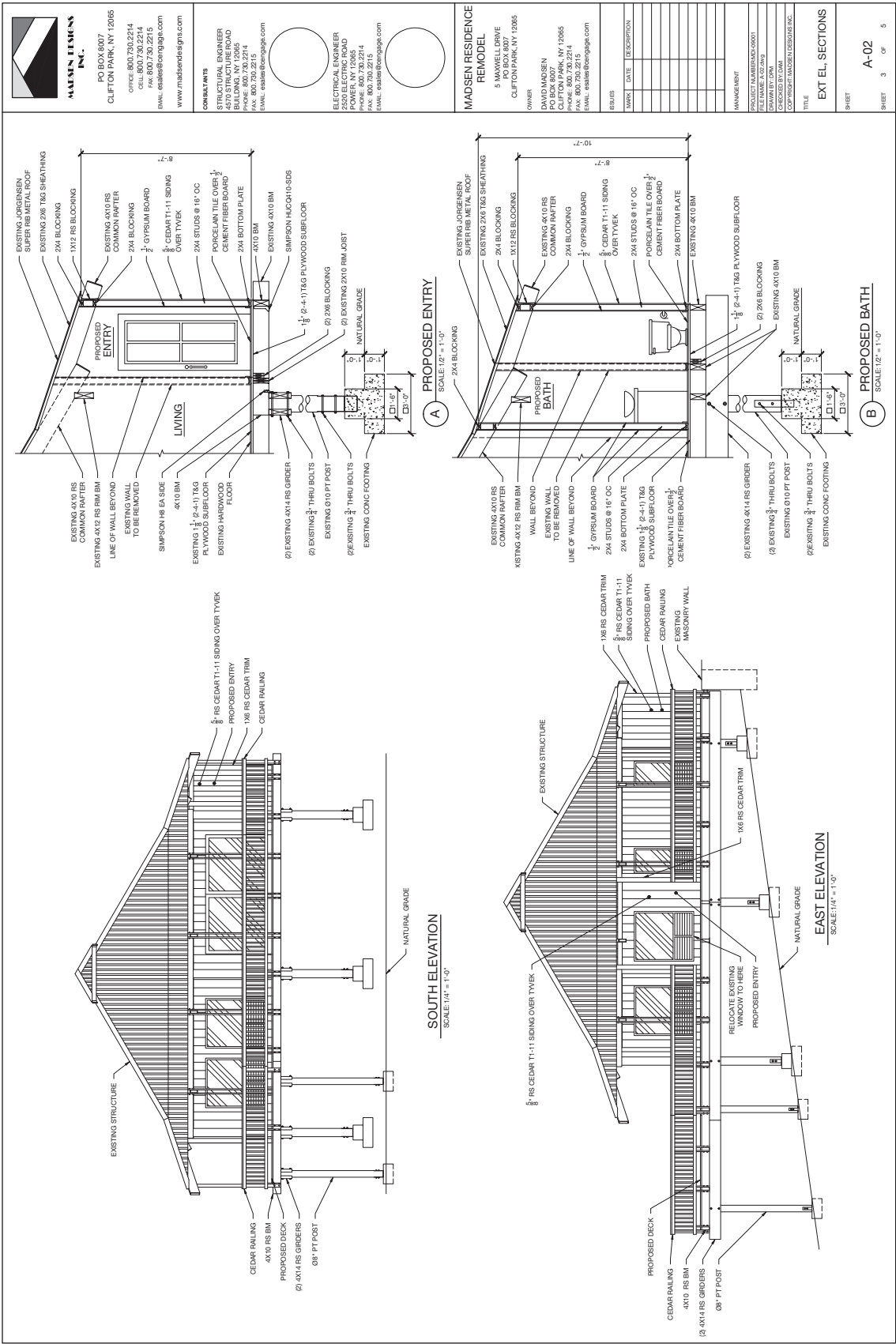
Engineering drawings communicate a variety of concepts, such as engineering requirements, instructions, and proposals, to a variety of people, such as the many different individuals often involved with a project. An engineering drawing or a complete set of engineering drawings provides all of the data required to manufacture or construct an item or product, such as a machine part, consumer product, or structure.

Study the drawing of the medical instrument part in Figure 1.7. The drawing completely and unmistakably describes the size and location of all geometric features, and it identifies other characteristics of the part, such as material and manufacturing precision and processes. The medical instrument company uses the drawing to share and document design intent and to manufacture the part. Consider how difficult it would be to explain the part without the engineering drawing.

Figure 1.8 shows another example of an engineering drawing, an architectural drawing for a home-remodeling project.



**FIGURE 1.7** This drawing of a medical instrument part completely and unmistakably describes the size and location of all geometric features, and it identifies other characteristics of the part. *Courtesy Wright Medical Technology, Inc.*



Madsen Designs Inc.

<p><b>MADSEN DESIGNS INC.</b> PO BOX 8007 CLIFTON PARK, NY 12085 OFFICE: 800.730.2214 CELL: 800.730.2214 FAX: 800.730.2215 EMAIL: esales@fordmga.com WWW.MADSENDIGNS.COM</p>	<p><b>CONTRACTS</b> STRUCTURAL ENGINEER 4870 STRUCTURE ROAD BUILDING, NY 12085 PHONE: 800.730.2214 FAX: 800.730.2215 EMAIL: esales@fordmga.com</p>	<p><b>ELECTRICAL CONTRACTOR</b> POWER, NY 12085 2320 ELECTRIC ROAD CLIFTON PARK, NY 12085 PHONE: 800.730.2214 FAX: 800.730.2215 EMAIL: esales@fordmga.com</p>	<p><b>MADSEN RESIDENCE REMODEL</b> 5 MAXWELL DRIVE PO BOX 8007 CLIFTON PARK, NY 12085</p>	
	<p>OWNER DAVID MADSEN PO BOX 8007 CLIFTON PARK, NY 12085 PHONE: 800.730.2214 FAX: 800.730.2215 EMAIL: david@fordmga.com</p>	<p>DATE: _____ MARKET: _____ DESCRIPTION: _____</p>	<p>MANAGEMENT PROJECT MANAGER: _____ FILE NAME: A-02 DRAWN BY: DMM CHECKED BY: DMM DATE: _____</p>	<p>TITLE EXT. ELEVATIONS</p>
	<p>NO. OF SHEETS: _____ SHEET: 3 OF 5</p>	<p>NO. OF SHEETS: _____ SHEET: A-02</p>	<p>NO. OF SHEETS: _____ SHEET: _____</p>	<p>NO. OF SHEETS: _____ SHEET: _____</p>

**FIGURE 1.8** This engineering drawing is an architectural drawing for a home-remodeling project. The drawing is one sheet in a set of drawings that communicates architectural style, the size and location of building features, and construction methods and materials.



The drawing is one sheet in a set of drawings that communicates architectural style, the size and location of building features, and construction methods and materials. The set of drawings is also required to obtain a loan to pay for construction, to acquire building permits to legally begin construction, and to establish accurate building cost estimates. Usually it is legally impossible and certainly impractical to begin construction without engineering drawings.

## Computers in Design and Drafting

The use of computers has revolutionized business and industry process, including design and drafting practices. **Computer-aided design and drafting (CADD)** is the process of using a computer with CADD **software** for design and drafting applications. Software is the program or instructions that enable a computer to perform specific functions to accomplish a task. **CAD** is the acronym for computer-aided design, but CAD is also a common reference to computer-aided drafting. Computer-aided design and computer-aided drafting refer to specific aspects of the CADD process. The use of CADD has made the design and drafting process more accurate and faster. Several industries and most disciplines related to engineering and architecture use CADD. Most engineering firms and educational institutions that previously used manual drafting practices have evolved to CADD.

CADD allows designers and drafters to produce accurate drawings that are very neat and legible and matched to industry standards. CADD can even produce architectural drawings, which have always had an artistic flair with lettering and line styles, to match the appearance of the finest handwork available. In addition, CADD drawings are consistent from one person or company to the next. CADD enhances the ability for designers and drafters to be creative by providing many new tools such as solid modeling, animation, and virtual reality. This textbook provides comprehensive CADD information throughout. Chapters 3 and 4 in this textbook cover CADD concepts and applications in detail.

## A HISTORY OF ENGINEERING DRAWING

Individuals with talent, wisdom, vision, and innovative ideas have influenced the history of engineering drawing. Major changes in agriculture, manufacturing, mining, and transport also greatly influenced the evolution of engineering drawing and had an overpowering effect on **socioeconomic** and **cultural** conditions between the eighteenth and nineteenth centuries. Recently and more rapidly, computers have become a driving force in the way people create engineering drawings.

### Early Drawing Practices

Prehistoric humans created images on cave walls and rocks as a form of communication for hunting and gathering societies, to provide ritual or spiritual meaning, and for decoration.



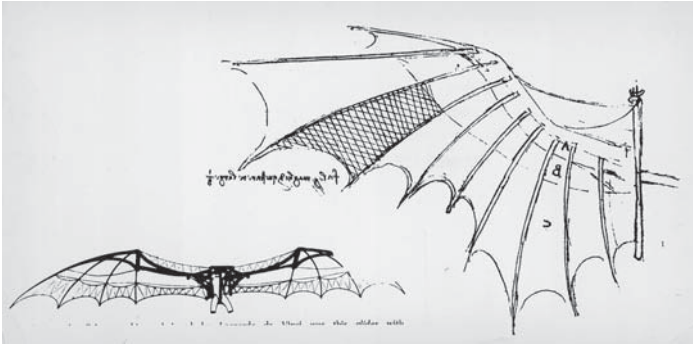
**FIGURE 1.9** Pictograms and petroglyphs are not engineering drawings, but they do represent early graphic forms of communication. Ancient bushmen rock engravings (petroglyphs) of animals and symbols at Twyfelfountain in Damaraland in Namibia. *Steve Allen/Photodisc/Getty Images*

Prehistoric drawings and paintings, known as **pictograms**, and carvings, known as **petroglyphs**, show a variety of animals and human shapes (see Figure 1.9). Pictograms and petroglyphs are not engineering drawings, but they do represent early graphic forms of communication. For thousands of years, designers of ancient structures and machines used sketches, drawings, and documents to represent inventions and architecture and help design and distribute information to workers. However, activities such as farming, craft making, and toolmaking, and construction generally followed established standards of the time without the use of formal drawings as a guide. Production was more like a form of art than engineering, and each item was unique.

Early engineering drawings representing machines and buildings appear in the fourteenth and fifteenth centuries. These drawings were generally in the form of pictorial sketches with written descriptions that helped workers understand the intent of the drawings for fabrication or building. Early engineering drawings served as a reference for craft workers to construct a building or manufacture a product. Craft workers viewed the drawings and written descriptions and made interpretations based on their own experience and knowledge of current standard practices. Specific dimensions were not necessary, because each building or machine was different. Early engineering drawings were also an art form used during presentations to the persons who requested the designs.

## Engineering Drawing Pioneers

Most early creators of engineering drawings were artists and inventors. Some of the best-known early engineering drawings are the work of Italian Leonardo da Vinci. Leonardo is well known for his art, such as *The Last Supper* in 1498 and the *Mona Lisa* in 1507. He was also an inventor who designed machines such as the glider shown in Figure 1.10 and military equipment such



**FIGURE 1.10** Leonardo da Vinci's design of the glider. *Frederic Lewis/Getty Images*

Image not available due to copyright restrictions

Text not available due to copyright restrictions

as the giant crossbow in Figure 1.11. Leonardo's drawings were those of an artist and were not in the form of engineering drawings. Leonardo's drawings were pictorial and generally without dimensions. No multiview drawings of Leonardo's designs are known to exist. Multiview drawings are 2-D drawings of objects organized in views. Chapter 9 of this textbook describes multiviews in detail.

Skilled tradespeople worked from the pictorial sketches and representations to construct models of many of Leonardo's designs. Each machine or device was unique, and parts were not interchangeable. Leonardo was also an early mapmaker. In 1502, Leonardo created a map containing the town plan of Imola, Italy. Authorities commissioned Leonardo as the chief military engineer and architect because of this mapmaking. Arguably, this early work was more artistic than the beginning of engineering drawing, but this work holds a special place in history.

Approximately the same time as Leonardo da Vinci created his drawings, awareness developed that drawings require

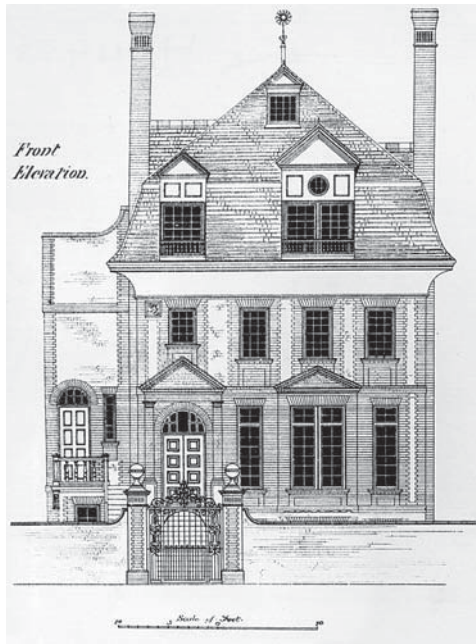
greater accuracy and dimensions. An early author of architecture and engineering was an Italian man, Leon Battista Alberti. Leon's writing covered a wide range of subjects, from architecture to town planning and from engineering to the philosophy of beauty. In 1435 and 1436, Leon also wrote two works that explored the need to incorporate more geometry in drawings. Leon also proposed drawings with multiple views rather than the commonly used pictorial drawings.

The importance of using multiview two-dimension drawings was also influenced by the development of descriptive geometry in the work of French philosopher and mathematician René Descartes (1596–1650) and the work of Frenchman Gaspard Monge (1746–1818). René was the inventor of the **Cartesian coordinate system**, and he founded **analytic geometry**, the link between algebra and geometry. The Cartesian coordinate system uses numerical coordinates to locate points in space according to distances measured in the same unit of length from three intersecting axes. The Cartesian coordinate system is the basis for establishing points when using CADD today.

Gaspard Monge created a large-scale plan of a town using his own methods of observation and instruments that he designed. As a result, authorities commissioned Gaspard as a drafter and pupil in the practical school of the military institution. Given a project to design a proposed fortress, Gaspard used his geometrical method to create the design quickly. Continuing his research, Gaspard arrived at a graphic method of the application of geometry to construction, now called **descriptive geometry**. Descriptive geometry is the system of graphic geometry that uses plane projections to describe and analyze their properties for engineering drafting applications.

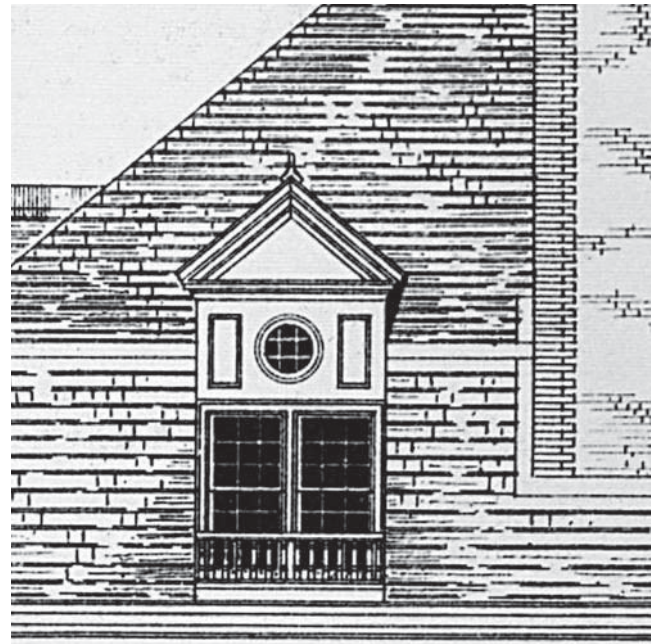
Many early drafters had degrees in engineering and began to realize the importance of creating accurate and detailed engineering drawings. However, much of the drafting was in the form of line drawings, with watercolor paints used to highlight the drawings as shown in the architectural elevation of a home in Figure 1.12. Drawing continued to be basic line drawings with little dimensioning practice. An example is the early architectural floor plans shown in Figure 1.13 used to construct a home. Craft workers also followed architectural details such as the gable design shown in Figure 1.14. There were few if any dimensions and standards, so each building was similar but different. This practice lasted until the early part of the twentieth century.

Into the late 1800s and early 1900s, inventors, engineers, and builders worked on each product on a one-of-a-kind basis. Manufactures produced parts from hand sketches or hand drawings on blackboards. American engineer and inventor Coleman Sellers, in the manufacture of fire engines, had blackboards with full-size drawings of parts. Blacksmiths formed parts and compared them to the shapes on the blackboards. Coleman Sellers son, George Sellers, recalls lying on his belly using his arms as a radius for curves as his father stood over him directing changes in the sketches until the drawings were satisfactory. Most designs used through the 1800s began as a hand sketches of the objects to be built. Workers then converted the sketches



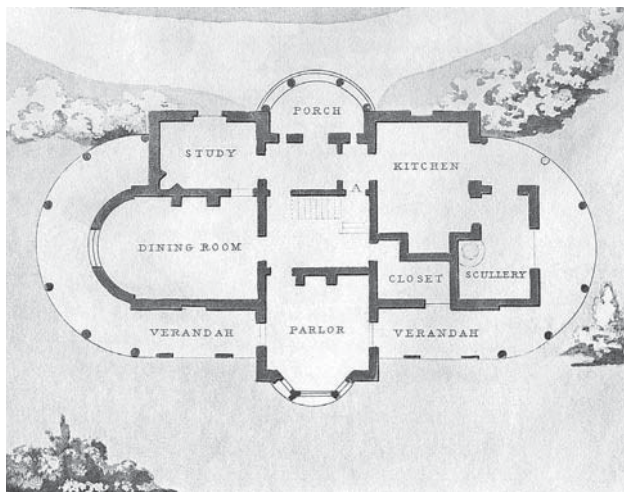
Hulton Archive/Getty Images

**FIGURE 1.12** Early drafting was often in the form of line drawings, with watercolor paints used to highlight the drawings as shown in this architectural elevation of a home.



Hulton Archive/Getty Images

**FIGURE 1.14** Craft workers also followed architectural details such as this gable design.



Buyenlarge/Getty Images

**FIGURE 1.13** An example of early architectural floor plans used to construct a home.

into wooden models from which patterns were constructed. Some companies followed this practice well into the twentieth century. An example is Henry Ford and his famous blackboards. What was new, though, was that the blackboards were also the Henry Ford drafting tables. Henry would sketch cars and parts three dimensionally and have pattern makers construct full-size wooden models.

## The Influence of Interchangeability

The Industrial Revolution was a period from the eighteenth to nineteenth centuries when major changes took place in agriculture, manufacturing, mining, and transport. The need for **interchangeability** in manufactured products became important during the Industrial Revolution. *Interchangeability* refers to parts manufactured identically within given tolerances. Interchangeable parts are produced to specifications that make sure they are so nearly identical that they fit into any product for which they are designed. One part can replace another of the same part without custom fitting. Interchangeability allows easy assembly of new products and easier repair of existing products, while minimizing the time and skill required for assembly and repair.

The application of interchangeability started with the firearms industry. Before the eighteenth century, gunsmiths made guns one at a time, and each gun was unique. If one component of a firearm needed to be replaced, the entire weapon was sent back to the gunsmith for custom repairs or the firearm was discarded. The idea of replacing these methods with a system of interchangeable manufacture gradually developed during the eighteenth century. Interchangeability was not realized except in special examples until the development of the micrometer in the late 1800s; even then, interchangeability was not easy to achieve. Without the concept of interchangeability, accurate drawings were not necessary. After these advances, engineering drawing began to evolve more rapidly in the nineteenth century.

## Drafting Practices and Equipment

Early engineering drawings were often works of art and commonly made with ink. Drafters initially drew using a pencil, T-square, triangles, scales, irregular (French) curves, and drawing instruments such as compasses and dividers. Drafting textbooks as late as the fourth edition of this textbook spent pages describing how to sharpen, hold, and properly use pencils to draw quality uniform lines. Drafters often traced original pencil drawings onto cloth using pen and ink. Drafters always paid skilled attention to lettering quality on drawings. Engineering drafters would use a specific lettering style referred to as *vertical uppercase Gothic*. Architectural drafters used a more artistic style of lettering that defined their drawings as uniquely related to their discipline. Over the years, various templates and other devices were introduced that allowed drafters to produce consistent quality lettering, although most professional drafters preferred to make quality freehand lettering.

Drafters initially created drawings by hand on a drafting table referred to as a *board*. An advance in drafting occurred with the introduction of the **drafting machine**, which replaced the T-square, triangles, scales and protractor for creating drawings. The drafting machine mounts to the table or board and has scales attached to an adjustable head that rotates for drawing angles. When locked in a zero position, the scales allow drawing horizontal and vertical lines and perpendicular lines at any angle orientation. There are **arm** and **track** drafting machines. The arm machine has arms attached to a mounting bracket at the top of the table. The arms control the movement of the head. The track machine has a traversing track that mounts to the table and a vertical track that moves along the horizontal track. The machine head traverses vertically on the track as shown in Figure 1.15.

Many architectural drafters used a device called a **parallel bar**, is a long horizontal drafting edge attached to each side of

the table that moves up and down on the table. The parallel bar allows the drafter to draw horizontal lines, and triangles are used on the bar to draw angled lines. During the decades after the World War II, drafting equipment suppliers introduced a variety of materials to improve the productivity of the drafting process.

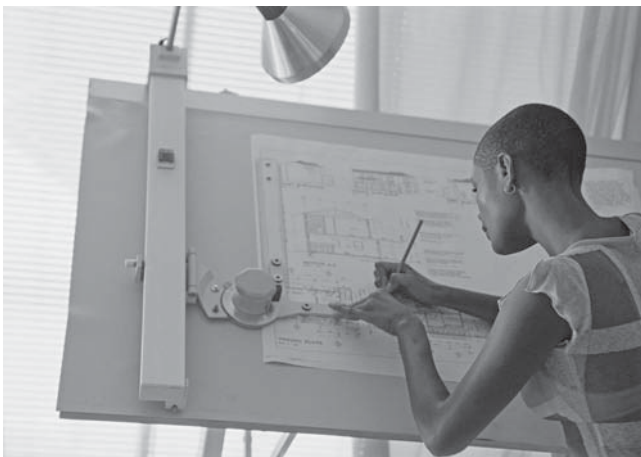
## Drawing Reproduction

About the same time as interchangeability became important and engineering drawings were evolving, preserving, and duplicating original drawings became important. There was a need to reproduce drawings easily for distribution to manufacturers or builders, so the **blueprint** process developed. A blueprint is a contact chemical-printing process of a drawing or other image copied on paper with white lines on a blue background. As drawing reproduction evolved, a diazo process that created blue line copies with a white background replaced the blueprint process. Until recently, all drawing reproductions were commonly referred to as blueprints. Today, offices use printers, plotters, and engineering copiers that use xerography to reproduce CADD drawings. The generic term **print** has replaced the term *blueprint*.

## Computer-Aided Design and Drafting

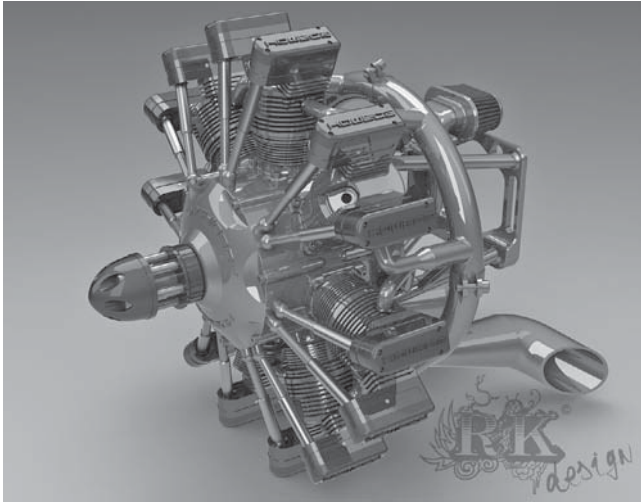
During the 1980s and 1990s, CADD rapidly became a technology to take seriously. Companies began considering the power of CADD as computer systems and CADD software developed capabilities and features that made them useful in producing professional drawings. Drafters who had used manual drafting for their entire careers had to face the challenge of converting their artistic skill into drawings created using a computer. This was a difficult challenge for many drafters. Soon schools began teaching drafting technology using CADD. This gave the traditional manual drafters an opportunity to learn the new technology and for new trainees to develop CADD knowledge and skills at the entry level.

In the 1980s, schools started teaching CADD in their curricula by adding a few computers into the traditional manual drafting program. Eventually, half of the typical classroom was equipped with traditional drafting tables and the other half was CADD workstations, or the school would open a separate CADD lab to teach courses. This plan closely paralleled what was happening in industry for those companies that were taking CADD seriously. By the 1990s, many schools and companies were starting to make the complete transition to CADD by replacing manual drafting tables with CADD workstations. Today, CADD accounts for almost all design and drafting. Figure 1.16 shows a 3-D model of an airplane engine, which demonstrates the power of CADD for designing products. Chapters 3 and 4 of this textbook describe CADD in detail. You will also learn specific CADD applications and disciplines throughout this textbook.



© Corbis Flirt / Alamy

**FIGURE 1.15** A drafter using a track drafting machine.



Courtesy of Solid Works Corporation

**FIGURE 1.16** This 3-D model of an airplane engine demonstrates the power of CADD for designing products.

## THE DRAFTER

The term **drafter** commonly refers to a man or woman who is employed in the drafting profession. Other general-purpose titles include **draftsperson**, **design drafter**, **drafting technician**, **engineering drafter**, **CADD operator**, and **CADD technician**. A job title can also be discipline or task specific. For example, a drafter who works for a civil engineering firm is a **civil drafter**, **civil engineering drafter**, **construction drafter**, or **civil CADD technician**. Several industries and most engineering and architectural related fields require drafters. According to the United States Department of Labor ([www.dol.gov](http://www.dol.gov)), most drafters work in the following industries:

- Professional, scientific, and technical services.
- Manufacturing.
- Construction.
- Administrative and support services.

## Occupational Outlook Handbook Definition

The *Occupational Outlook Handbook*, published by the United States Department of Labor, Bureau of Labor Statistics ([www.bls.gov/oco](http://www.bls.gov/oco)), uses the following to describe the nature of work performed by drafters:

Drafters prepare technical drawings and plans used by production and construction workers to build everything from microchips to skyscrapers. Drafters' drawings provide visual guidelines and show how to construct a product or structure. Drawings include technical details and specify dimensions, materials, and procedures. Drafters fill in technical details using drawings, rough sketches, specifications, and calculations made by engineers, surveyors, architects, or scientists. For example, many drafters use their knowledge of standardized building techniques to draw the details of structures.

Some use their understanding of engineering and manufacturing theory and standards to draw the parts of a machine; they determine design elements, such as the numbers and kinds of fasteners needed to assemble the machine. Drafters use technical handbooks, tables, calculators, and computers to complete their work.

Most drafters use CADD systems to prepare drawings. Accordingly, some drafters may be referred to as **CADD operators**. With CADD systems, drafters can create and store drawings electronically so that they can be viewed, printed, or programmed directly into automated manufacturing systems. CADD systems also permit drafters to prepare variations of a design quickly. Although drafters use CADD extensively, they still need knowledge of traditional drafting techniques in order to fully understand and explain concepts.

## DRAFTING FIELDS

Drafting is a broad occupation. There are many drafting fields and several drafting or related occupations within each field. The most common drafting fields include architecture, civil and electrical engineering, electronics, mechanical engineering, and industrial process-pipe drafting. Drafting in general has one basic description, but specific drafting areas have unique conceptual and skill characteristics. Drafters perform general duties described under the title of drafter in all drafting disciplines. Most drafters rely on knowledge of engineering or architectural principles, mathematical formulas, physical laws, and manufacturing or construction processes and limitations. Drafters typically work from analyzes, standards, specifications, sketches, engineering drawings, models, prototypes, verbal instructions, ideas, and related design data. Drafters then perform discipline and project specific tasks that require certain knowledge and skill. For example, an automotive design drafter requires knowledge of automotive vehicle design and manufacturing.

Drafters often create a variety of drawings even though they may be employed in a certain field or focus on a specific product. For example, an architectural drafter may be involved in preparing structural, electrical, plumbing, and civil drawings. A mechanical drafter may participate in simulation and analysis studies and create electronic drawings and technical illustrations. Drafters often work with a team, individuals of the same discipline, and others related to a specific project. For example, architectural drafters typically work with architects, architectural designers, and related architecture, engineering, and construction professionals.

The following information explores several specific drafting areas. The descriptions are taken, in part, from the Occupational Information Network (O\*NET), developed under the sponsorship of the U.S. Department of Labor, Employment and Training Administration ([online.onetcenter.org](http://online.onetcenter.org)), and including the *Standard Occupational Classification* published by the U.S. Department of Labor, Bureau of Labor Statistics ([www.bls.gov/soc](http://www.bls.gov/soc)). You will learn more about specific drafting fields and design and drafting applications throughout this textbook.

## Aeronautical Drafter

Aeronautical drafting is a specialization of mechanical drafting. Aeronautical drafters may create CADD models and drawings of airplanes, missiles, spacecraft, and components and related equipment, such as launch mechanisms.

## Architectural Drafter

Architectural drafters prepare CADD models and drawings of the architectural and structural features of a building. Figure 1.17 is an example of an architectural elevation. Figure 1.18 shows examples of architectural details. Architectural drafters rely on knowledge of building materials, codes, construction methods, and engineering practices. Architectural drafters work from specifications, sketches, and rough drafts. Architectural drafters may specialize in a type of building, such as residential or commercial, or a construction material, such as reinforced concrete, masonry, steel, or timber. Refer to the textbook titled *Architectural Drafting and Design* (sixth edition), published by Delmar, Cengage Learning, for more information on architectural drafting and design.

## Automotive Design Drafter

Automotive design drafting is a specialization of mechanical drafting. Automotive design drafters develop working layouts and master drawings of automotive vehicle components, assemblies, and systems.

## Cartographic Drafter

A cartographic drafter, also known as **cartographer**, draws maps of geographical areas to show natural and constructed features, political boundaries, and other features. Cartographers collect,

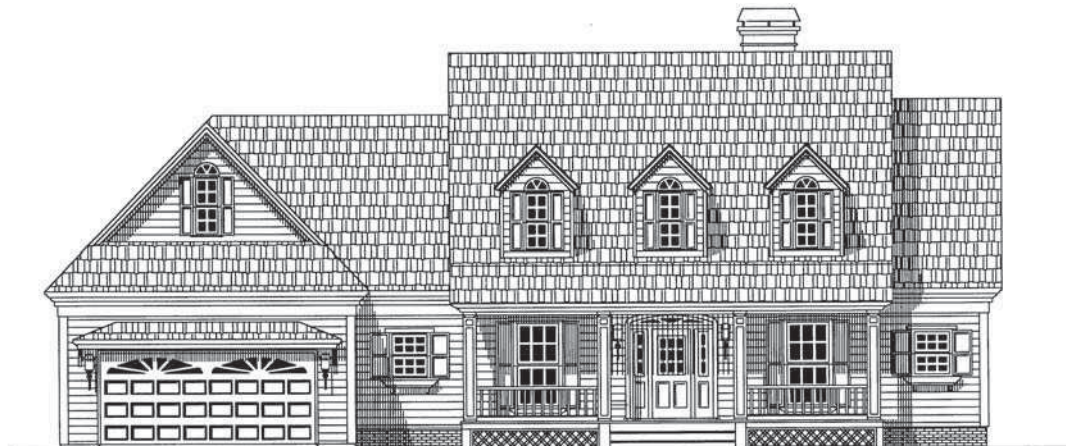
analyze, and interpret geographic information provided by geodetic surveys, aerial photographs, and satellite data. Cartographers research, study, and prepare maps and other spatial data in digital or graphic form for legal, social, political, educational, and design purposes. Cartographers may also work with and develop a geographic information system (GIS).

## Casting, Forging, and Mold Drafter

Casting, forging, and mold drafting is a specialization of mechanical drafting. Casting, forging, and mold drafters create CADD models and drawings for castings, forgings, and modeled parts. Castings, forgings, and molded parts require special knowledge and attention to die and mold design, shrinkage allowances, and various other factors such as corner radii.

## Civil Drafter

Civil drafters prepare CADD models and drawings used in construction or civil engineering projects, such as highways, bridges, pipelines, flood-control projects, and water and sewage systems. Figure 1.19 shows an example of a civil subdivision plat. Civil drafters create topographical and relief maps, and plot maps and charts showing profiles and cross sections, indicating relation of topographical contours and elevations to buildings, retaining walls, tunnels, overhead power lines, and other structures. Civil drafters prepare detailed drawings of structures and installations, such as roads, culverts, fresh-water supplies, sewage-disposal systems, dikes, wharfs, and breakwaters. Civil drafters also compute the volume of tonnage of excavations and fills and prepare graphs and hauling diagrams used in earthmoving operations. Civil drafters may accompany survey crew in field to locate grading markers or to



Courtesy Computer Aided Designs, Inc.

**FIGURE 1.17** Architectural elevations show the exterior shapes and finishes of a building and vertical relationships of the building levels.

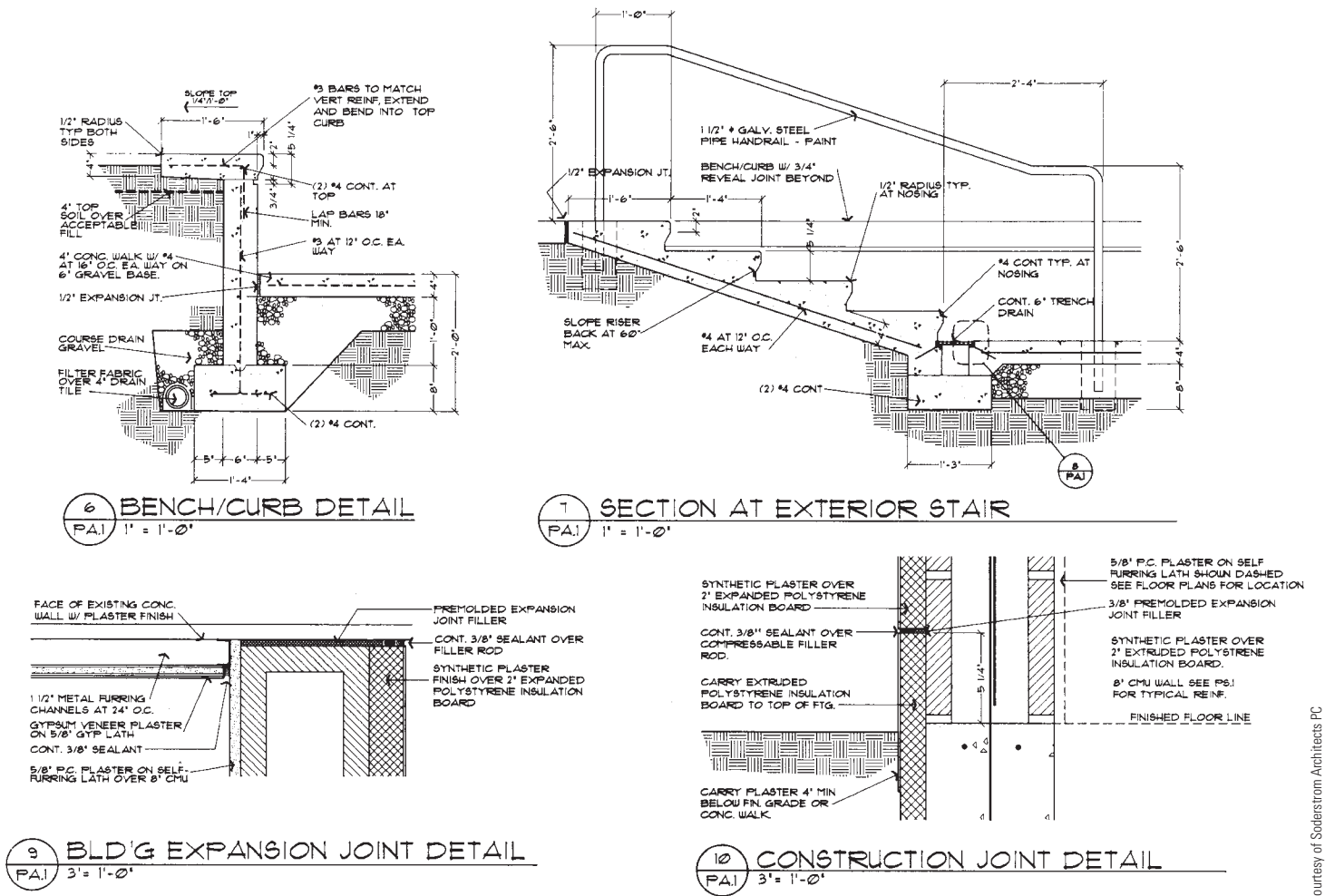


FIGURE 1.18 Architectural details describe construction materials and techniques.

collect data required for revision of construction drawings. A **topographical drafter** is a civil drafter who specializes in drafting and modifying topographical maps from surveying notes and aerial photographs.

### Commercial Drafter

Commercial drafting is a specialization of architectural drafting. A commercial drafter, also known as a **facilities drafter**, is responsible for laying out the location of buildings, planning the arrangements of offices, large rooms, store buildings, and factories, and drawing charts, forms, and records. A commercial drafter may also create 3-D rendered models.

### Directional Survey Drafter

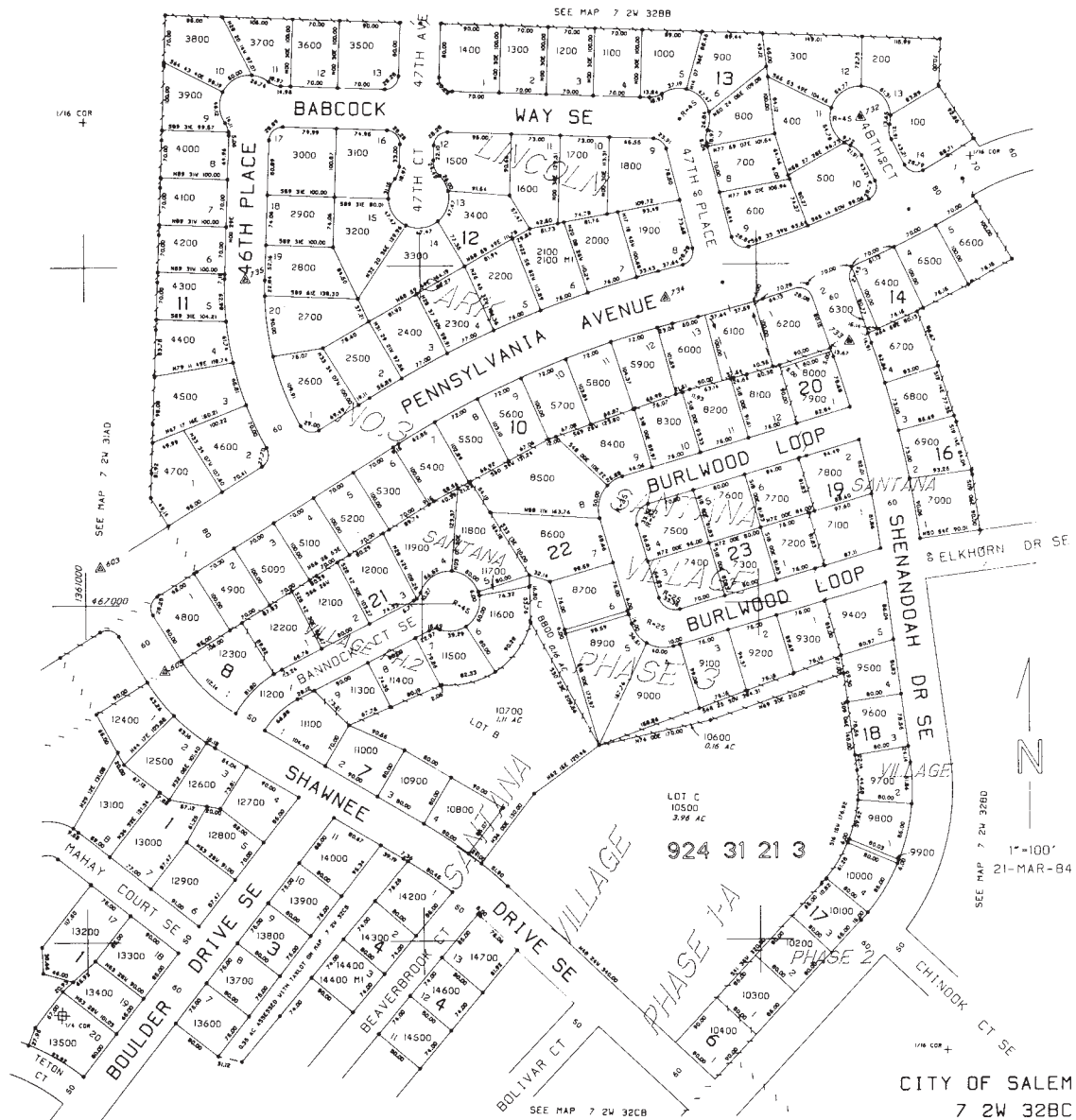
Direction survey drafting is a specialization of civil drafting. Directional survey drafters plot oil- or gas-well boreholes

from photographic subsurface survey recordings and other data. Directional survey drafters compute and represent diameter, depth, degree, and direction of inclination, location of equipment, and other dimensions and characteristics of boreholes.

### Electrical Drafter

Electrical drafters generate CADD models and drawings of electrical equipment, wiring diagrams, circuit-board assembly diagrams, and layout drawings used by construction crews and repairers who erect, install, and repair electrical equipment and wiring in communications centers, power plants, industrial establishments, commercial and domestic buildings, and electrical distribution systems (see Figure 1.20). An **electric-cable diagrammer** is an electrical drafter who specializes in preparing detail cable layout and diagrams for cable installation.

Courtesy of Soderstrom Architects PC



**FIGURE 1.19** A civil drafting subdivision plat required for the development of a residential housing subdivision.

Courtesy Glad's Project

## Electronic Drafter

Electronic drafters produce CADD models and drawings, such as wiring diagrams, layout drawings, mechanical detail drawings, and drawings of intermediate and final assemblies that are used in manufacturing, assembling, installing, and repairing electronic devices and components, printed circuit boards, and equipment (see Figure 1.21). Electronic drafters examine electronic schematics and supporting documents received from design engineering departments to develop, compute, and verify specifications in drafting data, such as configuration of parts, dimensions, and tolerances.

## Geological Drafter

Geological drafters draw maps, diagrams, profiles, cross sections, directional surveys, and subsurface formations to represent geological or geophysical stratigraphy and locations of gas and oil deposits. Geological drafters correlate and interpret data obtained from topographical surveys, well logs, and geophysical prospecting reports and use special symbols to denote geological and geophysical formations or oil field installations.



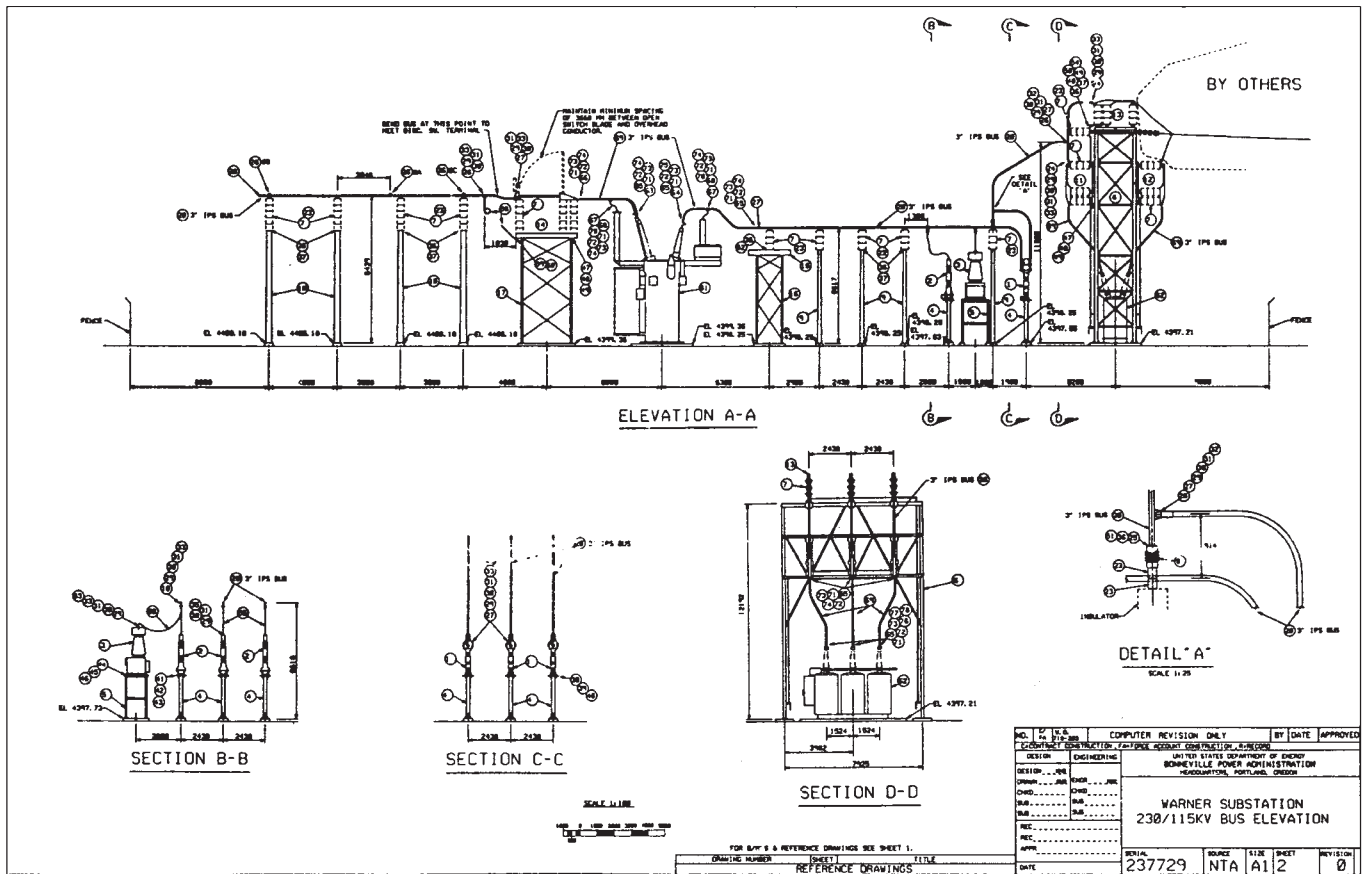


FIGURE 1.20 Electrical drafting substation elevation, sections, and detail.

## Geophysical Drafter

Geophysical drafters draw subsurface contours in rock formations from data obtained by geophysical prospecting. Geophysical drafters plot maps and diagrams from computations based on recordings of seismographs, gravity meters, magnetometers, and other petroleum-prospecting instruments and from prospecting and surveying field notes. Geophysical drafters sometimes receive a title such as seismograph drafter, according to a specific method of prospecting.

## Heating, Ventilating, and Air-Conditioning Drafter

Heating, ventilating, and air-conditioning drafters generally work for an HVAC engineering firm developing contract documents from engineering schematics (see Figure 1.22a). HVAC drafting may involve light design work in sizing and routing systems to conform to the allotted space with the building structure, as well as calculating heat loss and heat gain for buildings for use in determining equipment specifications. HVAC drafting may also involve trade-to-trade coordination on an elemental level. A refrigeration drafter specializes in drawing plans

for installation of refrigeration equipment. A detail drafter, or detailer, works for an HVAC contractor developing 3-D models, detailed shop and installation drawings, performing trade-to-trade coordination to a finished degree and developing fabrication cutsheets (see Figure 1.22b). Detailers can also be involved in download to or input into a sheet metal fabrication software program.

## Industrial Process-Pipe Drafter

An industrial process-pipe drafter—also known as an industrial pipe drafter, a piping drafter, and a pipeline drafter—prepares CADD models and drawings used in the layout, construction, and operation of oil and gas fields, refineries, chemical plants, and process-piping systems (see Figure 1.23). Industrial process-pipe drafters develop detail drawings for construction of equipment and structures, such as drilling derricks, compressor stations, and gasoline plants; frame, steel, and masonry buildings; piping manifolds and pipeline systems; and for the manufacture, fabrication, and assembly of machines and machine parts. Industrial process-pipe drafters prepare maps to represent geological stratigraphy, pipeline systems, and oil and gas locations, using field survey notes, geological and geophysical

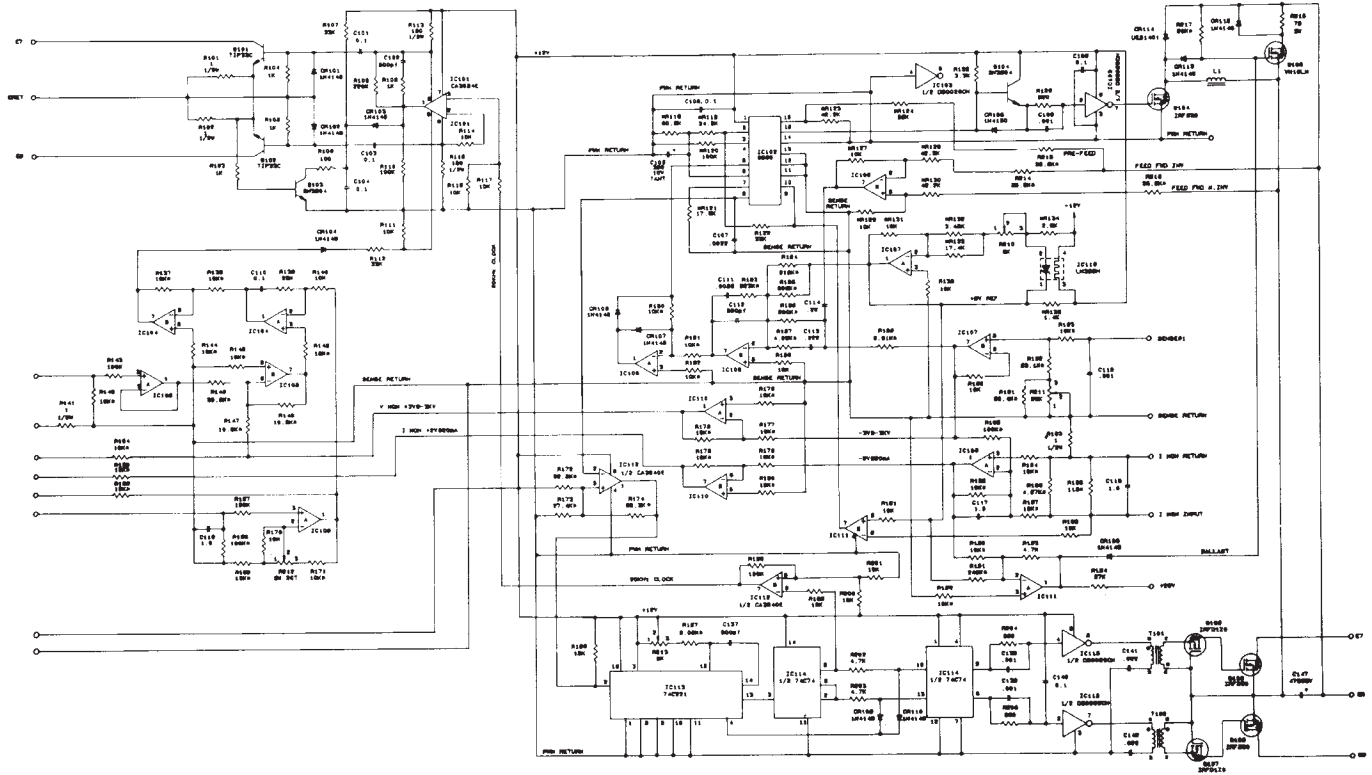


FIGURE 1.21 Electronics schematic.

Courtesy of Archway Systems, Inc.

prospecting data, and aerial photographs. An **oil and gas drafter** is an industrial process-pipe drafter who specializes in oil and gas industrial pipe drafting.

## Landscape Drafter

Landscape drafters prepare CADD models and drawings from rough sketches or other data provided by landscape architects. Landscape drafters may prepare separate detailed site plans, grading and drainage plans, lighting plans, paving plans, irrigation plans, planting plans, and drawings and details of garden structures (see Figure 1.24). Landscape drafters may build models of proposed landscape construction and prepare colored drawings for presentation to clients.

## Mechanical Drafter

The manufacturing industry uses **mechanical drafting**, its name derived from *mechanisms*. The construction industry also uses mechanical drafting, but the term refers to drafting HVAC systems, which is the mechanical portion of an architectural project. In general, mechanical drafting is the core of the **engineering drafting** industry. The terms *engineering drawing* and *engineering drafting* used throughout this textbook refer

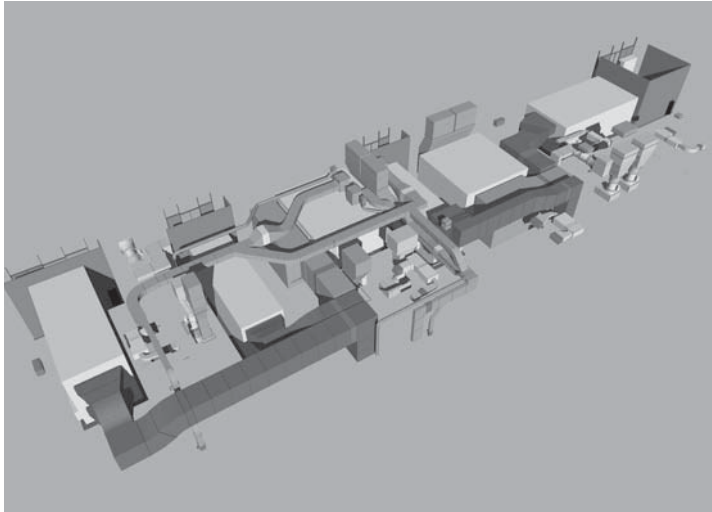
to all drafting disciplines. A mechanical drafter, also known as an **engineering drafter**, is a drafter associated with mechanical drafting for the manufacturing industry. Mechanical drafters create CADD models and drawings of machinery and mechanical devices, indicating dimensions and tolerances, fastening and joining methods, and other engineering data and requirements. Mechanical drafters draw multiple-view part, assembly, subassembly, and layout drawings as required for manufacture and repair of machines and equipment. Figure 1.25 shows an example of a part drawing.

## Marine Drafter

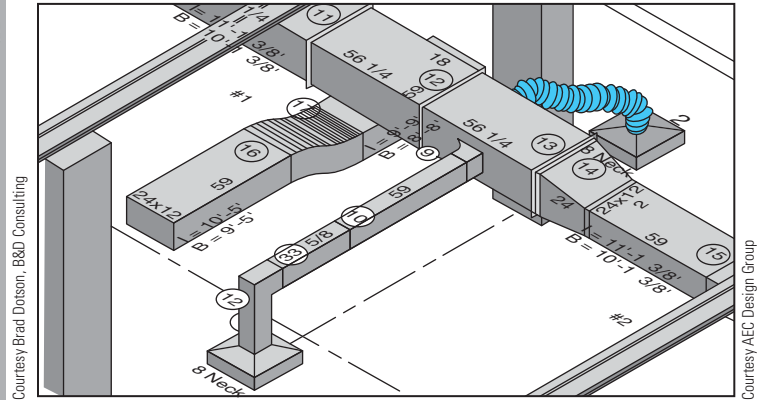
Marine drafting is a specialization of mechanical and structural drafting. Marine drafters develop CADD models and drawings of structural and mechanical features of ships, docks, and other marine structures and equipment.

## Patent Drafter

Patent drafters prepare clear and accurate drawings of varied sorts of mechanical devices for use of patent lawyer in obtaining patent rights. The “Patents” section toward the end of this chapter provides additional information on patents and patent drawings.



(a)



(b)

FIGURE 1.22 (a) A CADD model of an HVAC system. (b) A portion of a 3-D HVAC drawing created using CADPIPE HVAC software.

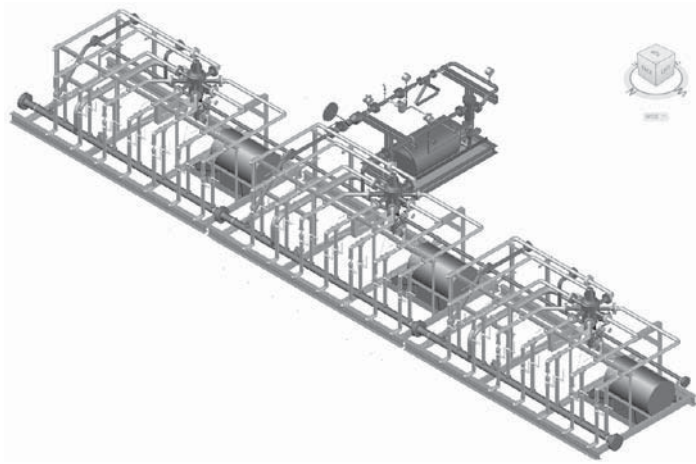


FIGURE 1.23 A 3-D CADD model of an industrial process-piping system. Courtesy PROCAD Software

## Photogrammetrist

Photogrammetrists analyze source data and prepare mosaic prints, contour-map profile sheets, and related cartographic materials that require technical mastery of photogrammetric techniques and principles. Photogrammetrists prepare original maps, charts, and drawings from aerial photographs and survey data and apply standard mathematical formulas and photogrammetric techniques to identify, scale, and orient geodetic points, estimations, and other planimetric or topographic features and cartographic detail. Photogrammetrists graphically represent aerial photographic detail, such as contour points, hydrography, topography, and cultural features, using precision stereoplotting apparatus or drafting instruments.

Photogrammetrists revise existing maps and charts and correct maps in various states of compilation. Photogrammetrists also prepare rubber, plastic, or plaster 3-D relief models.

## Plumbing Drafter

A plumbing drafter, also known as a **pipe drafter**, specializes in CADD models and drawings for installing plumbing and piping equipment in residential, commercial, and industrial settings (see Figure 1.26). Commercial and industrial piping relate closely to industrial process-pipe drafting.

## Structural Drafter

Structural drafters create CADD models and drawings for structures that use reinforcing steel, concrete, masonry, wood, and other structural materials. Structural drafters produce plans and details of foundations, building frame, floor and roof framing, and other structural elements (see Figure 1.27). A **detail drafter**, or detailer, works for a structural contractor developing 3-D models, detailed shop drawings, and installation drawings, performing trade-to-trade coordination to a finished degree, and developing fabrication drawings. Detailers may also be involved in downloading to or inputting into a structural component fabrication software.

## Technical Illustrator

Technical illustrators lay out and draw illustrations for reproduction in reference works, brochures, and technical manuals dealing with assembly, installation, operation, maintenance, and repair of machines, tools, and equipment. Technical illustrators prepare drawings from blueprints, designs mockups,



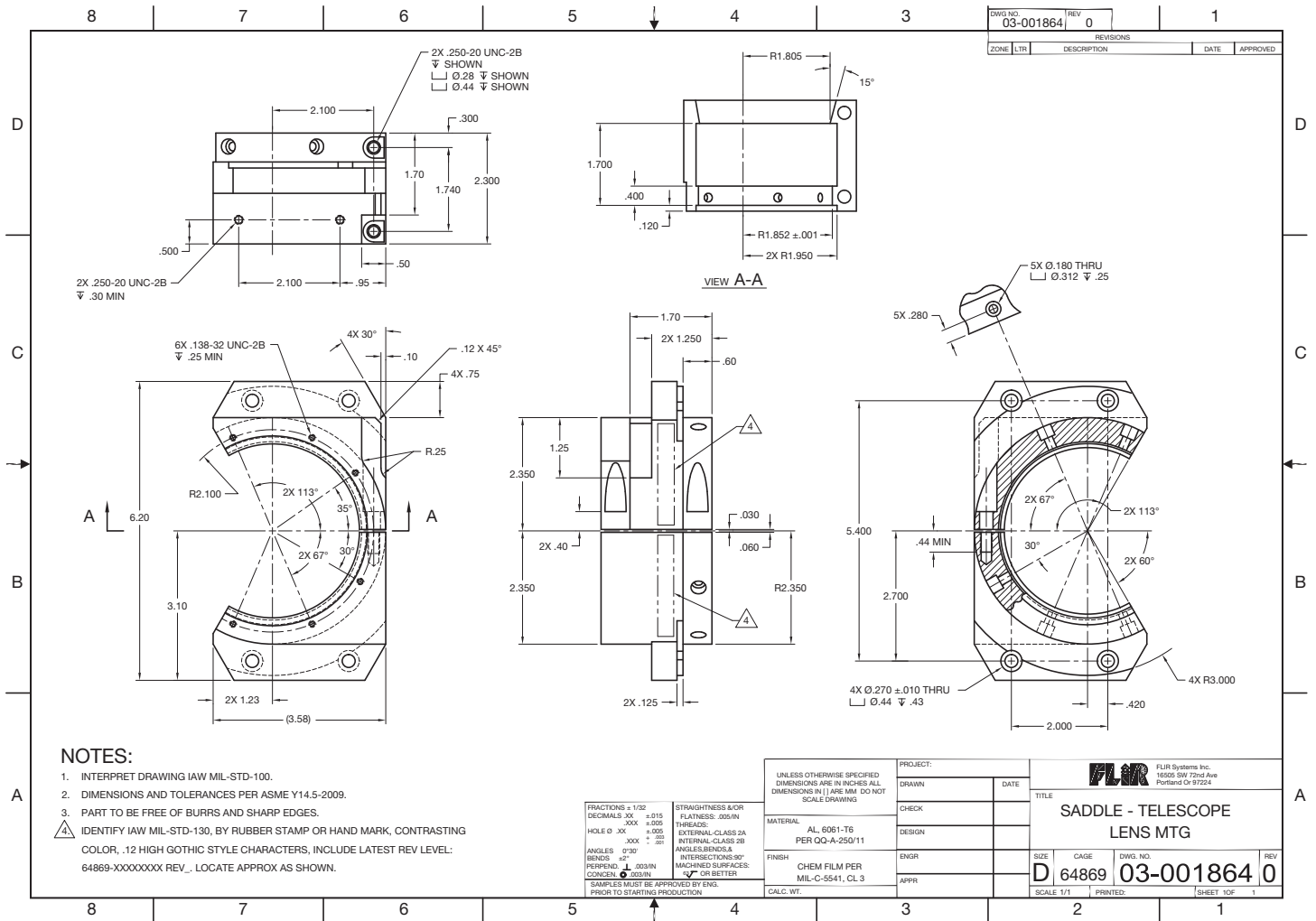


FIGURE 1.25 A mechanical drawing of a part for a thermal camera assembly. Courtesy FLIR Systems, Inc.

and photographs by methods and techniques suited to specified reproduction process or final use, photo-offset, and projection transparencies, using drafting and optical equipment. Technical illustrators create schematic, perspective, axonometric, orthographic, and oblique-angle views to depict functions, relationships, and assembly sequences of parts and assemblies such as gears, engines, and instruments. Technical illustrators also create rendered drawings and 3-D models, and they may draw cartoons and caricatures to illustrate operation, maintenance, and safety manuals and posters (see Figure 1.28).

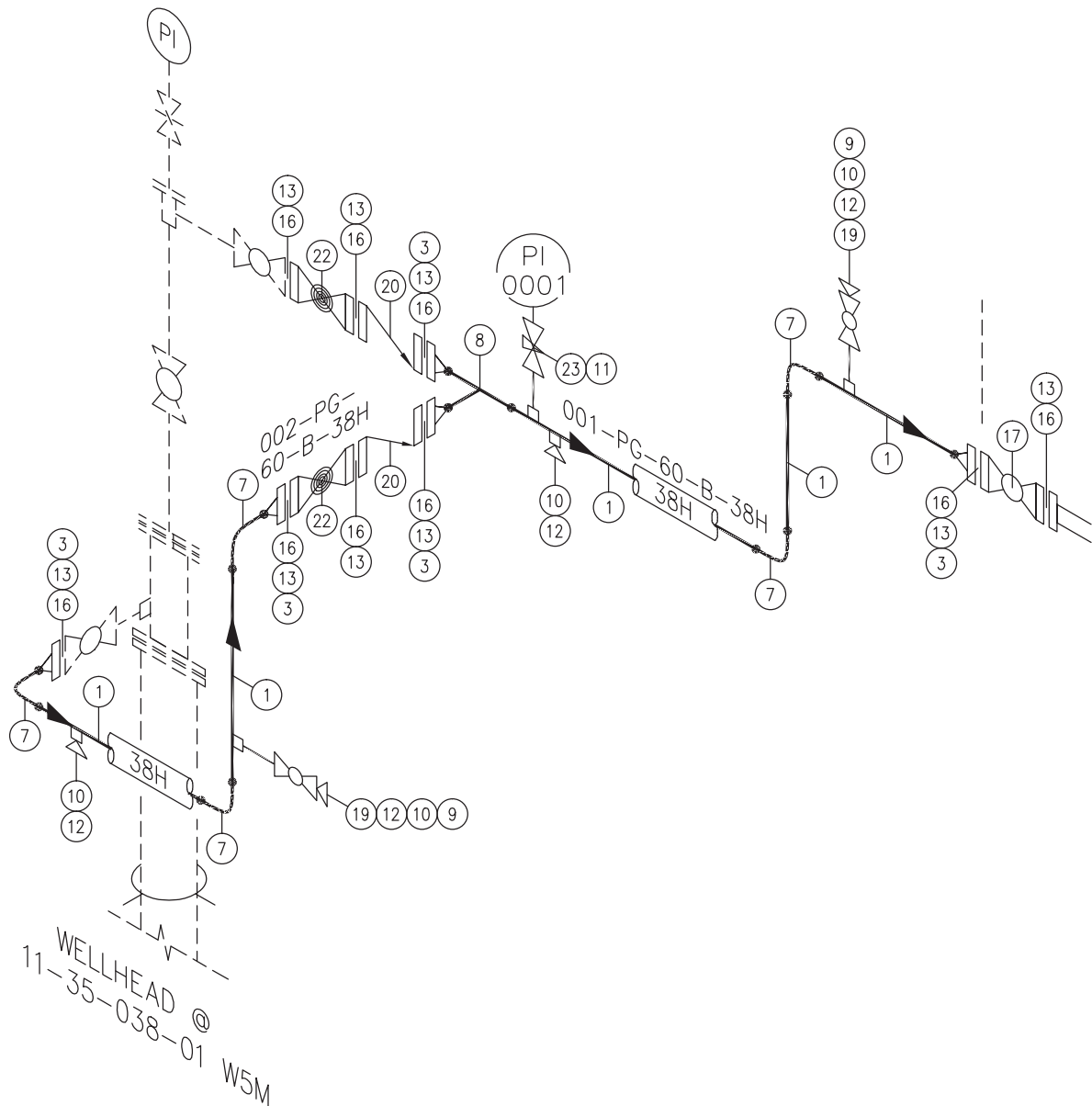
### Tool-and-Die Design Drafter

Tool-and-die design drafting is a specialization of mechanical drafting. Tool-and-die design drafters prepare CADD models and detailed drawing plans for manufacturing tools, usually following designs and specifications indicated by tool designers.

## EDUCATION AND QUALIFICATIONS

The design and drafting profession can provide a rewarding career for people who enjoy detailed work and have a mechanical aptitude and ability to visualize. Math and communication skills are also important. The following information describes education and qualification requirements for an entry-level drafting position. The information is taken partly from the *Occupational Outlook Handbook* published by the U.S. Department of Labor, Bureau of Labor Statistics ([www.bls.gov/oco](http://www.bls.gov/oco)).

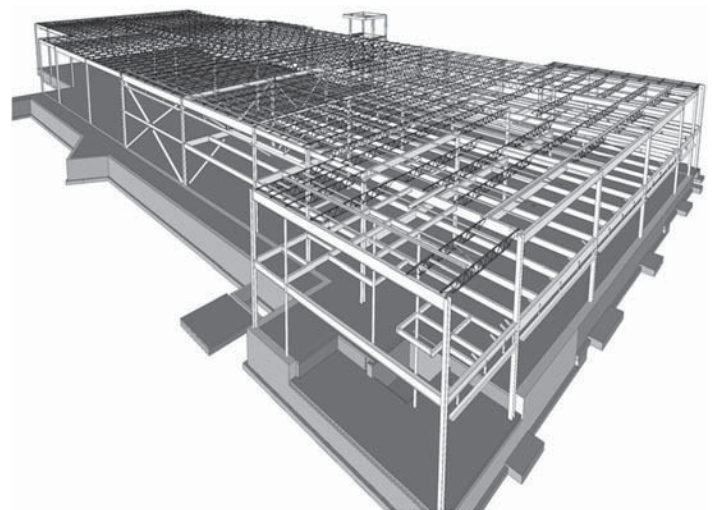
High school courses in mathematics, science, computer technology, design, computer graphics, and drafting are useful for people considering a drafting career. However, employers in the drafting industry prefer applicants who have at least two years of postsecondary training in a drafting program that provides strong technical skills and considerable experience with CADD systems. Employers are most interested in applicants with a strong background in fundamental drafting principles;



**FIGURE 1.26** Isometric piping layout. Courtesy PROCAD Software

well-developed drafting skills; knowledge of drafting standards, mathematics, science, and engineering technology; a solid background in CADD techniques; and the ability to apply their knowledge to a broader range of responsibilities. Future students should contact prospective employers to ask which schools they prefer and contact schools to ask for information about the kinds of jobs their graduates have, the type and condition of instructional facilities and equipment available, and teacher qualifications.

Many technical institutes, community colleges, and some four-year colleges and universities offer drafting programs. Technical institutes offer intensive technical training, but they provide a less general education than do community colleges.



**FIGURE 1.27** Structural CADD model. Courtesy Pinnacle Infotech

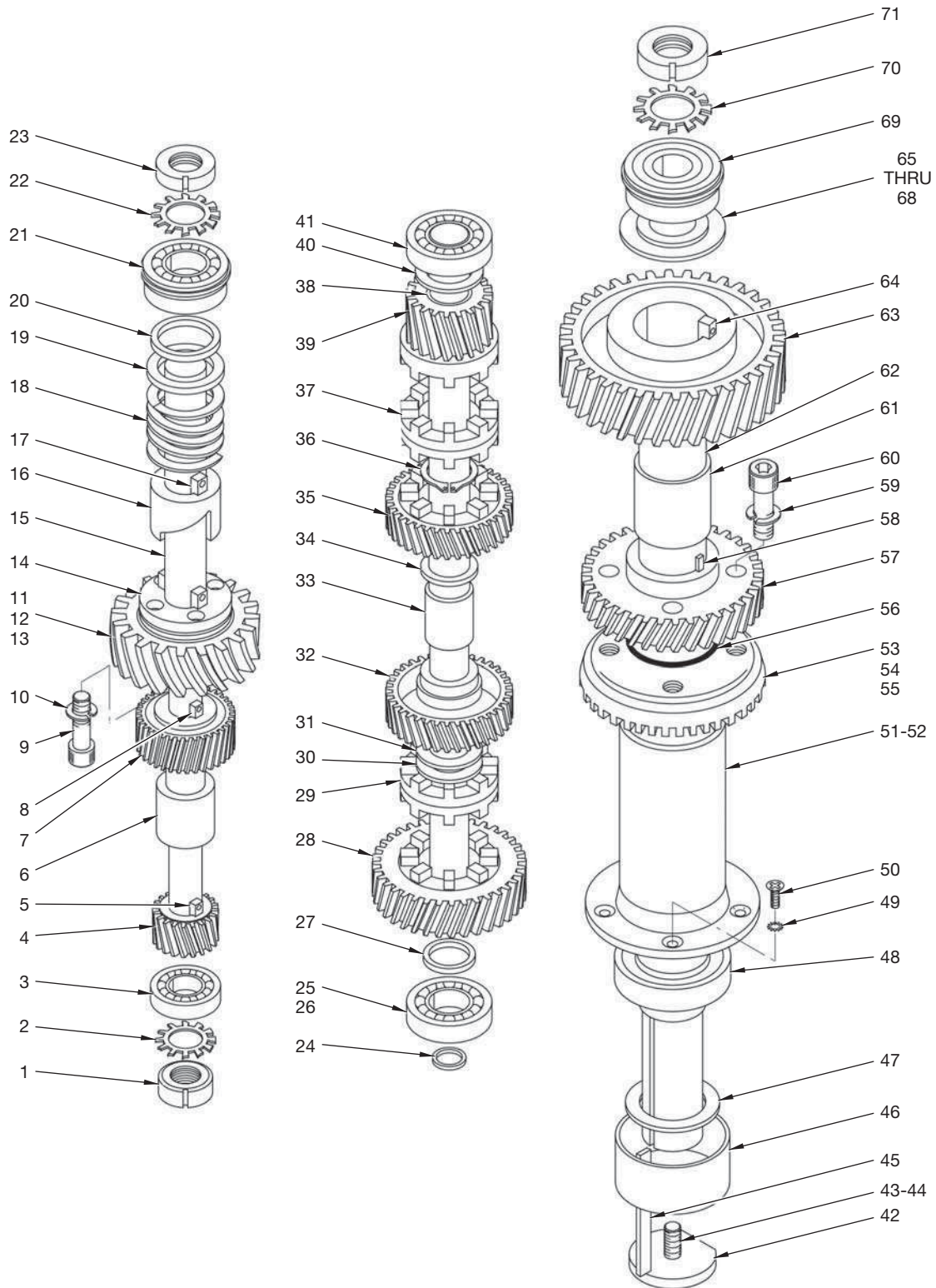


FIGURE 1.28 Technical illustration, exploded isometric assembly.

Courtesy O'Neil & Associates, Inc.

Technical institutes may award either certificates or diplomas, and programs can vary considerably in length and in the types of courses offered. Many technical institutes offer two-year associate degree programs. Community colleges offer programs similar to those in technical institutes but include more classes in drafting theory and also often require general education classes. After completing a two-year associate degree program, graduates may obtain jobs as drafters or continue their education in a related field at a four-year college. Most four-year colleges do not offer training in drafting, but they do offer classes in engineering, architecture, and mathematics that are useful for obtaining a job as a drafter. Technical training obtained in the armed forces can also apply in civilian drafting jobs. Some additional training may be necessary, depending on the technical area or military specialty.

Mechanical drafting—the type of drafting done for the manufacturing industry—offers the fundamental standards involved in the design and drafting profession. However, there are a variety of design and drafting discipline categories. Training differs somewhat within the drafting specialties, although the basics, such as mathematics, are similar. In an electronics drafting program, for example, students learn how to show electronic components and circuits in drawings. In architectural drafting, students learn the technical specifications of buildings. Some educational programs provide training in specific disciplines, whereas others provide diversified training in several areas. The opportunity to experience more than one discipline allows you to find an industry that you prefer.

## General Qualifications and Certification

Mechanical ability and visual aptitude are important for drafters. Prospective drafters should be able to perform detailed work accurately. Artistic ability is helpful in some specialized fields, as is knowledge of manufacturing and construction methods. In addition, future drafters should have good interpersonal skills because they work closely with engineers, surveyors, architects, and other professionals and sometimes with customers.

Although employers usually do not require drafters to be certified, certification demonstrates knowledge and an understanding of nationally recognized practices. The ADDA International, a design and drafting industry organization fully described later in this chapter, has established a certification program for drafters. Individuals who wish to become ADDA certified must pass the ADDA Drafter Certification Test, administered periodically at ADDA-authorized sites.

## Advancement

Opportunities for advancement for drafters are excellent, although dependent on the advancement possibilities of a specific employer. Advancement also depends on your skill, initiative, ability, product knowledge, attitude, ability to communicate, continued education, and enthusiasm. Entry-level

or junior drafters usually do routine work under close supervision. After gaining experience, drafters may become intermediate drafters and progress to more difficult work with less supervision. At the intermediate level, drafters may need to exercise more judgment and perform calculations when preparing and modifying drawings. Drafters may eventually advance to senior drafter, designer, or supervisor.

An entry-level drafting position may not be in your chosen field, but you should be able to find employment in your desired area with experience and an open job market. Opportunities are available that allow people to expand career potential into related areas such as tool design and cartography. Many people who enter the drafting industry begin to move up quickly into design, checking, purchasing, estimating, and management. Many employers pay for continuing education. Additional education for advancement usually includes increased levels of mathematics, pre-engineering, engineering, software, and advanced drafting. Appropriate college degrees may allow drafters to go on to become engineering technicians, engineers, or architects. Drafting has traditionally been an excellent way into designing, engineering, and management.

## DRAFTING JOB OPPORTUNITIES

Drafting job opportunities, which include all possible drafting employers, fluctuate with national and local economies. Employment as a drafter remains tied to industries that are sensitive to cyclical changes in the economy, primarily construction and manufacturing. A slowdown or speedup in construction and manufacturing nationally affects the number of drafting jobs available. The economic effect on drafting job opportunities also occurs at the local level or with specific industries. For example, construction may be strong in one part of the country and slow in another, so the demand for drafters in those localities is strong or slow accordingly. Fewer drafters are required when large manufacturers, such as automobiles, experience poor sales. More drafters are required when industries such as high-tech expand. In addition, a growing number of drafters should continue to find employment on a temporary or contract basis as more companies turn to the employment services industry to meet their changing needs.

Local demands also generally control the types of drafting jobs available. Each local area usually has a need for more of one type of drafting skill than another. In general, metropolitan areas where manufacturing is strong offer more mechanical drafting jobs than rural areas, which typically offer more civil or structural drafting jobs than other disciplines. Drafting curriculums in different geographical areas usually specialize in the fields of drafting that help fill local employment needs. A broader range of opportunities exists in many local areas because of the flexibility of electronic data transfer, making it possible to complete tasks worldwide. Some drafting programs offer a broad-based education so graduates can have versatile employment opportunities. When selecting a school, research



curriculum, placement potential, and local demand. Talk to representatives of local industries for an evaluation of the drafting curriculum.

## SEARCHING FOR A DRAFTING POSITION

Entry-level drafting positions require you to be prepared to meet the needs and demands of industry. Entry into the drafting career marketplace depends on your training and ability and on the market demand. Your training, skills, and personal presentation are especially important in a poor economic environment, and these can make the difference in finding an employment opportunity.

A two-year, postsecondary degree in drafting can also provide a big advantage when seeking a position in the drafting industry. Programs of this type normally have a quality cross section of training in design and drafting, math, and communication skills. Two-year, postsecondary drafting programs often have job-preparation and placement services to aid their graduates. Many of these schools have direct industry contacts that help promote hiring opportunities. Training programs also often have cooperative work experience (CWE) or internships in which their students work in industry for a designated period while completing degree requirements. These positions allow a company to determine if the student is a possible candidate for full-time employment and provide the student with valuable on-the-job experience to include on a résumé. Even if you do not go to work for the company where you do CWE or an internship, you can get a letter of recommendation for your portfolio.

When the local economy is doing well and drafting job opportunities are plentiful, it may be possible to find a job with less than a two-year college degree. If you want to find entry-level employment in a job market of this type, you can take intensive training in CADD practices. The actual amount of training required depends on how well you do and whether you can match an employer who is willing to hire with your level of training. Many people have entered the industry in this manner, although you would be well advised to continue schooling toward a degree while you are working.

## Job-Seeking Strategy

The following are some points to consider when you are ready to seek employment:

- Get your résumé in order. Take a résumé-preparation course or get some help from your instructors or a career counselor. Your résumé must be a quality and professional representation of you. When an employer has many résumés, the best stands out.
- Write an application or cover letter. You can receive help with an application or cover letter from the same people who help with your résumé. Write a professional and clear application letter that is short, to the point, and lists the reasons why you would be an asset to the company.
- Prepare a portfolio. Your portfolio should contain examples of school and industry drawings that you have completed. Neatly organize the drawings and select examples that help you target the specific industry discipline that you are seeking. For example, include mechanical models and drawings if you are interviewing with a company in the manufacturing industry. Display architectural models and drawings if you are interviewing with an architect or building designer. Include letters of recommendation from employers and instructors with your portfolio.
- Register with the department, school, and state employment service. Watch the employment ads in local newspapers and check out Internet employment sites, as described later in this chapter.
- Make a realistic decision about the type of place where you want to work and the salary and benefits you realistically think you should get. Base these decisions on sound judgment. Your instructors should have this information for the local job market. Do not make salary your first issue when seeking a career position. The starting salary is often just the beginning at many companies. Consider advancement potential. A drafting technology position often is a stepping-stone to many opportunities, such as design, engineering, and management.
- Research prospective companies to learn about their business or products. The Internet is a good place to seek information, because most companies have a Web site. This type of research can help you during an interview.
- Be prepared when you get an interview. First impressions are critical. You must look your best and present yourself well. Figure 1.29 shows a job candidate making the first introduction for a possible employment opportunity. Always be on time or early. Relax as much as you can. Answer questions clearly and to the point, but with enough detail to demonstrate that you know what you are talking about. It is often unwise to talk too much. Show off your portfolio. Be prepared to take a CADD test or demonstrate your skills.
- Ask intelligent questions about the company during an interview because you need to decide if you want to work there. For example, you may not want to work for a company that has no standards, poor working conditions, and pirated software. You might prefer to work for a company that has professional standards and CADD systems, a pleasant work environment, and advancement possibilities.
- Respond quickly to job leads. The employment marketplace is often very competitive. You need to be prepared and move quickly. Follow whatever instructions an employer gives for you to apply. Sometimes employers want you to go in person to fill out an application, and sometimes they want you to e-mail, fax, or mail a résumé. Either way, you can include your application letter and résumé. Sometimes employers want you to call for a preinterview screening.



**FIGURE 1.29** A candidate for an employment opportunity making the first introduction. You must present yourself well. First impressions are very important. © Cengage Learning 2012

- In an active economy, it is common to get more than one offer. If you get an offer from a company, take it if you have no doubts. However, if you are uncertain, ask for 24 or 48 hours to make a decision. If you get more than one offer, weigh the options carefully. There are advantages and disadvantages with every possibility. Make a list of the advantages and disadvantages with each company for careful consideration.
- Once you make a decision, you need to feel good about it and move on with enthusiasm. Figure 1.30 shows a new employee working at a CADD position.
- Send a professionally written thank-you letter to the companies where you interviewed. Phone the companies and send follow-up letters where you had offers. This is an important step because you never know when you might need to apply at these companies in the future.

## Employment Opportunities on the Internet

The Internet is a valuable place to seek employments. There are hundreds of Web sites available to help you prepare for and find a job. Many Web sites allow you to apply for jobs and post your resume for possible employers. Some employers screen applicants over the Internet. Figure 1.31 shows a person looking for a job opportunity on the Internet. The only caution is that any Internet-displayed personal information is



**FIGURE 1.30** A new employee, working at a CADD position. © Lloyd Sutton/Alamy



**FIGURE 1.31** A person looking for a job opportunity on the Internet. © Cengage Learning 2012

available for anyone to read. However, some Web sites such as [www.monster.com](http://www.monster.com) provide a safe place to post your résumé for only employers to review. You should always confirm that the terms of agreement provide you with a safe place to search for employment.

## DRAFTING SALARIES AND WORKING CONDITIONS

Salaries in drafting professions are comparable to salaries of other professions with equal educational requirements. Employment benefits vary according to each employer.

However, most employers offer vacation and health insurance coverage, and some include dental, life, and disability insurance.

## PROFESSIONAL ORGANIZATION

ADDA is the acronym for the American Design Drafting Association and the American Digital Design Association ([www.adda.org](http://www.adda.org)). The ADDA International is a professional industry organization dedicated to the advancement of design and drafting and the graphics professions across all industries. The ADDA sponsors the following programs and activities for the design drafting profession:

- Leadership Opportunities.
- Drafter, Designer, and Technician Certification Program.
- Certified Curriculum Program—Approving curriculum that meets or exceeds industry standards.
- Councils—Local Professional Organizations.
- Chapters—Student Organizations.
- Annual Design Drafting Week.
- Annual Poster Contest.
- Annual Design Drafting Contest.
- Product Approval—Verification of a product's quality, durability, usability, and value.
- Publication Approval—Verification of the publications content relative to the industry.
- Publications such as the *Drafting Examination Review Guides*.
- Employment Center.
- Annual Technical and Educational Conference.
- Additional Member Resources, including publication and product discounts, networking, and a members only forum.

## A Short History of the ADDA

The ADDA was born in Bartlesville, Oklahoma, in 1948 by a dedicated and enthusiastic group of oil and gas piping drafters who were involved in various phases of design drafting. This group consisted of highly specialized industry drafters, educators, piping designers, and engineering personnel. For more information about the ADDA, including a detailed history of the organization, go to the ADDA International Web site ([www.adda.org](http://www.adda.org)) and pick the About ADDA link on the left, then Read more . . . under ADDA History.

## Professional Certification Program

The ADDA professional certification examinations are international certification programs that allow apprentice drafters, drafters, designers, design drafters, design technicians, engineering and architectural technicians, digital imaging technicians, and other graphic professionals to indicate

their knowledge in professional concepts and internationally recognized standards and practices. The ADDA developed these examinations to elevate an individual's comprehension of the professional standards related to design drafting and the graphics profession.

Certification allows drafters to demonstrate professional capabilities and helps employers identify quality employees. The tests do not cover specific CADD software or graphic production. The ADDA Drafter Certification Examination is open to all individuals, regardless of experience and formal education. An ADDA membership is not required to take the test or to become certified. Becoming a Certified Drafter reflects your proven knowledge of drafting. Certification enhances your credibility as a professional, improves your opportunities for promotion and pay increases, and gives you a competitive edge in a highly technical job market.

When employers hire an ADDA Certified Drafter, they know that the new employee meets certification criteria and has demonstrated initiative and pride in the profession by becoming certified. Thus, certification can serve as one criterion for differentiating among candidates in the selection process. Certification serves educators as a supplementary measurement of a student's performance on a recognized national level.



### ADDA Professional Certification Competencies

To view the **ADDA Professional Certification Examination Series, Competencies by Level & Discipline** document, go to the Student CD, select **Supplemental Material, Chapter 1**, and then **ADDA Professional Certification Competencies**.

## Student Chapters

ADDA student organizations are called *chapters*. Chapter members are student members of ADDA and work together as a miniversion of ADDA. Each chapter elects its own officers and has its own advisory committee and a chapter adviser, who is usually an instructor.



### ADDA Student Chapter Information

To view the **ADDA Student Chapter Program Information & Requirements** document, go to the Student CD, select **Supplemental Material, Chapter 1**, and then **ADDA Student Chapter Information**.

## ADDA Employment Center

The ADDA Employment Center is available to help connect ADDA members with new employment opportunities. Post your résumé online if you are seeking work. Access the newest jobs available by employers to professionals seeking employment. Use the following links to the **ADDA Employment Center**: Go to the **ADDA International** Web site ([www.adda.org](http://www.adda.org)) and pick the **Employment Center** link on the left, followed by the desired **ADDA—Employment Center** resources.

## DRAFTING STANDARDS

Most industries, schools, and companies establish **standards**, which are guidelines that specify drawing requirements, appearance, and techniques, operating procedures, and record-keeping methods. The American Society of Mechanical Engineers (ASME) ([www.asme.org](http://www.asme.org)) defines the term *standard* as a set of technical definitions and guidelines, how-to instructions for designers, manufacturers, and users. Standards promote safety, reliability, productivity, and efficiency in almost every industry that relies on engineered components or equipment. Standards can be as short as a few paragraphs or hundreds of pages long, but they are written by experts with knowledge and expertise in a particular field who sit on many committees. The ASME defines the term *code* as a standard that one or more governmental bodies adopts and has the force of law. Standards are considered voluntary because they serve as guidelines. Standards become mandatory when a business contract or regulations incorporate them.

Standards are important for engineering communication, because they serve as a common language, defining quality and establishing safety criteria. Costs are lower and training is simplified when procedures are standardized. Interchangeability is another reason for standardization, so a part manufactured in one location fits with a mating part manufactured in another location.

Drawing standards apply to most settings and procedures, including:

- CADD file storage, naming, and backup.
- **File templates**, which are files that contain standard file settings and objects for use in new files.
- Units of measurement.
- Layout characteristics.
- Borders and title blocks.
- Symbols.
- Layers, and text, table, dimension, and other drafting styles.
- Plot styles and plotting.

Company or school drawing standards should follow appropriate national industry standards. Though standards vary in content, the most important aspect is that standards exist and are understood and used by all design and drafting personnel. When you follow drawing standards, drawings are consistent,

you become more productive, and the classroom or office functions more efficiently.

This textbook presents engineering drafting standards developed by the ASME and accredited by the American National Standards Institute (ANSI). This textbook also references International Organization for Standardization (ISO) engineering drafting standards, and discipline-specific standards when appropriate, including American Welding Society (AWS) standards and the United States National CAD Standard (NCS).

## ASME Drafting Standards

The ASME is a professional engineering organization for mechanical engineering. The ASME publishes standards documents, sponsors technical conferences and educational programs, and conducts professional development courses. The ASME is an accredited standards developing organization that meets requirements of ANSI. Codes and standards developed under an accredited program can be designated as American National Standards. ANSI is a privately funded federation of business and industry, standards developers, trade associations, labor unions, professional societies, consumers, academia, and government agencies. ANSI does not write standards.

The ASME publishes standards for numerous disciplines. Most ASME standards that focus on specific areas of engineering drawing and related practices receive the Y14 designation. For example, ASME Y14.3, *Multiview and Sectional View Drawings*, focuses on multiview and sectional view drafting techniques. ASME Y14.5, *Dimensioning and Tolerancing*, describes approved dimensioning and tolerancing practices. For more information or to order standards, go to the ASME Web site at [www.asme.org](http://www.asme.org).



### ASME Drafting Standards List

For a partial list of ASME drafting standards and related documents, go to the Student CD, select **Supplemental Material, Chapter 1**, and then **ASME Drafting Standards List**.

## ISO Drafting Standards

The ISO is an international organization that currently includes members from 163 countries. The United States is a member, represented by the ANSI. The ISO provides an extensive list of drafting standards and related documents. The ISO 2768 standard, *General Tolerances*, details specific ISO dimensioning and tolerancing practices. This standard is particularly important when preparing a metric drawing according to ASME/ANSI standards, because the ISO normally controls metric tolerancing. A general note that states the ISO 2768 class for general

tolerances, such as ISO 2768-m, shall be placed on the drawing. For more information or to order standards, go to the ISO Web site at [www.iso.org](http://www.iso.org).

## CADD Skill Standards

The United States Department of Labor ([www.dol.gov](http://www.dol.gov)) published Occupational Skill Standards Projects in 1996. The Computer-Aided Drafting and Design (CADD) skill standards, developed in cooperation with the National Coalition for Advanced Manufacturing (NACFAM) ([www.nacfam.org](http://www.nacfam.org)), summarizes CADD occupation skills generic to all CADD disciplines, software, and entry level.



### CADD Skill Standards

For more information on the national CADD skill standards project, go to the Student CD, select **Supplemental Material, Chapter 1**, and then **CADD Skill Standards**.

## AWS Drafting Standards

The AWS publishes drafting standards related to welding technology and related joining disciplines. The AWS A2.4:2007 standard, *Standard Symbols for Welding Brazing and Non-destructive Examination*, provides detailed information about welding, brazing, and nondestructive examination symbol specifications, meaning, and application. For more information or to order standards, go to the AWS Web site at [www.aws.org](http://www.aws.org).

## United States National CAD Standard

A group of agencies, including the CADD/GIS Technology Center (CGTC), the American Institute of Architects (AIA), the Construction Specifications Institute (CSI), the U.S. Coast Guard, the Sheet Metal and Air Conditioning Contractors National Association (SMACNA), and the National Institute of Building Sciences (NIBS), developed the U.S. National CAD Standard (NCS) in 1997. The NCS primarily applies to architectural and construction-related disciplines and includes the following three documents:

- The American Institute of Architects (AIA) CAD Layer Guidelines.
- The Construction Specifications Institute (CSI) Uniform Drawing System, Modules 1–8.
- The CSI Plotting Guidelines.

For more information or to order the NCS, go to the U.S. National CAD Standard Web site at [www.buildingsmartalliance.org/ncs/](http://www.buildingsmartalliance.org/ncs/).



### United States National CAD Standard

For a comprehensive introduction to the NCS, go to the Student CD, select **Supplemental Material, Chapter 1**, and then **United States National CAD Standard**.

## WORKPLACE ETHICS

**Ethics** are rules and principles that define right and wrong conduct. A **code of ethics** is a formal document that states an organization's values and the rules and principles that employees are expected to follow. In general, a code of ethics contains the following main elements: be dependable, obey the laws, and be good to customers. An example of a company with a corporate code of ethics is the Lockheed Martin Corporation, recipient of the American Business Ethics Award. According to Lockheed Martin ([www.lockheedmartin.com](http://www.lockheedmartin.com)), the company aims to set the standard for ethical business conduct through six virtues:

1. *Honesty*: to be truthful in all our endeavors; to be honest and forthright with one another and with our customers, communities, suppliers, and shareholders.
2. *Integrity*: to say what we mean, to deliver what we promise, and to stand for what is right.
3. *Respect*: to treat one another with dignity and fairness, appreciating the diversity of our workforce and the uniqueness of each employee.
4. *Trust*: to build confidence through teamwork and open, candid communication.
5. *Responsibility*: to speak up, without fear of retribution, and report concerns in the workplace, including violations of laws, regulations, and company policies, and seek clarification and guidance whenever there is doubt.
6. *Citizenship*: to obey all the laws of the United States and the other countries in which we do business and to do our part to make the communities in which we live better.

## Intellectual Property Rights

The success of a company often relies on the integrity of its employees. Products are normally the result of years of research, engineering, and development. This is referred to as the **intellectual property** of the company. Protection of intellectual property can be critical to the success of the company in a competitive industrial economy. This is why it is very important for employees to help protect design ideas and trade secrets. Many companies manufacture their products in a strict, secure, and secret environments. You will often find

proprietary notes on drawings that inform employees and communicate to the outside world that the information contained in the drawing is the property of the company and is not for use by others.

## Software Piracy

**Software piracy** is the unauthorized copying of software. Most software licenses support use at one computer site or by one user at any time. When you buy software, you become a licensed user. You do not own the software. You are allowed to make copies of the program for backup purposes, but it is against the law to give copies to colleagues and friends. Software companies spend a lot of money creating software programs for your professional and personal applications. Each new release normally provides you with improved features and more efficient use. When you use software illegally, you hurt everyone by forcing software companies to charge more for their products. Ethically and professionally, use software legally and report illegal use when observed.

## COPYRIGHTS

A **copyright** is the legal rights given to authors of **original works of authorship**. The United States Constitution, Article 1, Section 8, establishes copyright and patent law and empowers the United States Congress to **promote the progress of science and useful arts, by securing for limited times to authors and inventors the exclusive right to their respective writings and discoveries**. Copyrights control exclusively the reproduction and distribution of the work by others. In the United States, published or unpublished works that are typically copyrightable include:

- Literary works, including computer programs and compilations.
- Musical works, including any accompanying words.
- Dramatic works, including any accompanying music.
- Pantomimes and choreographic works.
- Pictorial, graphic, and sculptural works.
- Motion pictures and other audiovisual works.
- Sound recordings.
- Architectural works and certain other intellectual works.

Copyright protection exists from the time the work is created in fixed form. Fixed form may not be directly observable; it can be communicated with the aid of a machine or device. The copyright in the work of authorship immediately becomes the property of the author who created the work. Copyright is secured automatically when the work is created, and the work is created when it is fixed in a copy or phonorecorded for the first time. **Copies** are material objects from which the work can be read or visually perceived directly or with the aid of a machine or device. A copyright notice can

be placed on visually perceptible copies. The copyright notice should have the word *Copyright*, the abbreviation *Copr.*, or the symbol © (or ® for phonorecords of sound recordings); the year of first publication; and the name of the owner of the copyright.

Copyright registration is a legal formality intended to make a public record, but it is not a condition of copyright protection. Register a copyright claim by sending a copy of unpublished work or two copies of the work as published, with a registration application and fee, to the Library of Congress, United States Copyright Office, Washington D.C. ([www.copyright.gov](http://www.copyright.gov)). Online registration is available, or you can submit a paper application form. Confirm specific copyright details and requirements with the United States Copyright Office.

## Patents

A **patent** for an invention is the grant of a property right to the inventor, issued by the United States Department of Commerce, United States Patent and Trademark Office (USPTO) ([www.uspto.gov](http://www.uspto.gov)). The term of a new patent is 20 years from the date on which the application for the patent was filed in the United States or, in special cases, from the date an earlier related application was filed, subject to the payment of maintenance fees. United States patent grants are effective only within the United States, United States territories, and United States possessions. The patent law states, in part, that any person who “invents or discovers any new and useful process, machine, manufacture, or composition of matter, or any new and useful improvement thereof, may obtain a patent,” subject to the conditions and requirements of the law.

The patent law specifies that the subject matter must be “useful.” The term *useful* refers to the condition that the subject matter has a useful purpose and must operate. You cannot patent laws of nature, physical phenomena, and abstract ideas. A complete description of the actual machine or other subject matter is required to obtain a patent.

## Application for a Patent

The USPTO offers nonprovisional and provisional patent applications. A nonprovisional patent application is for the full patent, which lasts 20 years. The provisional patent application is for a temporary patent that lasts for one year.

### Nonprovisional Application for a Patent

According to the USPTO, a nonprovisional application for a patent is made to the assistant commissioner for patents and includes:

1. a written document that has a specification and an oath or declaration,

2. a drawing in those cases in which a drawing is necessary, and
3. the filing fee.

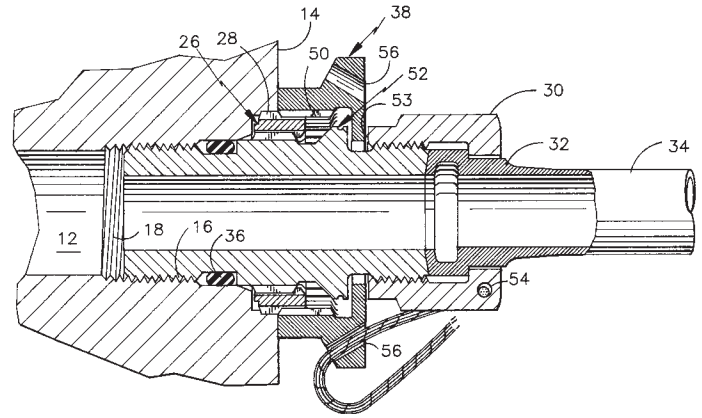
All application papers must be in the English language, or a translation into the English language is required. All application papers must be legibly written on only one side by either a typewriter or mechanical printer in permanent dark ink or its equivalent in portrait orientation on flexible, strong, smooth, nonshiny, durable, white paper. Present the papers in a form having sufficient clarity and contrast between the paper and the writing to permit electronic reproduction. The application papers must all be the same size, either 21.0 cm by 29.7 cm (DIN size A4) or 21.6 cm by 27.9 cm (8½ × 11 in.). Application documents must have a top margin of at least 2.0 cm (¾ in.), a left-side margin of at least 2.5 cm (1 in.), a right-side margin of at least 2.0 cm (¾ in.), and a bottom margin of at least 2.0 cm (¾ in.), with no holes made in the submitted papers. It is also required that the spacing on all papers be 1½ or double spaced, and the application papers must be numbered consecutively, centrally located above or below the text, starting with page 1. All required parts of the application must be complete before sending the application, and it is best to send all of the elements together. The USPTO numbers all applications received in serial order, and the applicant will be informed of the application serial number and filing date by a filing receipt.

### Provisional Application for a Patent

Since June 8, 1995, the USPTO has offered inventors the option of filing a provisional application for patent that was designed to provide a lower-cost first patent filing in the United States and to give United States applicants equality with foreign applicants. A provisional application does not require claims and oath or declaration. Provisional application provides the means to establish an early effective filing date in a patent application and permits applying the term “Patent Pending” in connection with the invention. Provisional applications may not be filed for design inventions. The filing date of a provisional application is the date on which a written description of the invention, drawings if necessary, and the name of the inventor(s) are received in the USPTO.

### Patent Drawings

According to the *Guide for the Preparation of Patent Drawings*, published by the USPTO, drawings form an integral part of a patent application. The drawing must show every feature of the invention specified. Figure 1.32 shows a proper patent drawing from the USPTO publication. There are specific requirements for the size of the sheet on which the drawing is made, the type of paper, the margins, and other details relating to creating the drawing. The reason for specifying the standards in detail is that the drawings are printed and published in a uniform style when



**FIGURE 1.32** A proper patent drawing shown as an example in the United States Patent and Trademark Office publication, *Guide for the Preparation of Patent Drawings*. © Cengage Learning 2012

persons using the patent descriptions also must understand the patent issues and the drawings.

Drawings must be created using solid black ink lines on white media. Color drawings or photographs are accepted on rare occasions, but there is an additional petition and other specific requirements for submitting a color drawing or photograph. Chapter 25 of this textbook provides additional information about patents. Confirm specific patent details and requirements with the USPTO.

### TRADEMARKS

According to the USPTO publication *Basic Facts about Registering a Trademark*, a **trademark** is a word, phrase, symbol or design, or combination of words, phrases, symbols, or designs that identifies and distinguishes the source of the goods or services of one party from those of others. A **service mark** is the same as a trademark except that it identifies and distinguishes the source of a service rather than a product. Normally, a mark for goods appears on the product or on its packaging, whereas a service mark appears in advertising for services. A trademark is different from a copyright or a patent. As previously explained, a copyright protects an original artistic or literary work, and a patent protects an invention.

Trademark rights start from the actual use of the mark or the filing of a proper application to register a mark in the USPTO stating that the applicant has a genuine intention to use the mark in commerce regulated by the U.S. Congress. Federal registration is not required to establish rights in a mark, nor is it required to begin use of a mark. However, federal registration can secure benefits beyond the rights acquired by just using a mark. For example, the owner of a federal registration is presumed to be the owner of the mark for the goods and services specified in the registration and to be entitled to use the mark

nationwide. Generally, the first party who either uses a mark in commerce or files an application in the USPTO has the ultimate right to register that mark. The authority of the USPTO is limited to determining the right to register. The right to use a mark can be more complicated to determine, particularly when two parties have begun use of the same or similar marks without knowledge of one another and neither has a federal registration. Only a court can make a decision about the right to use. A federal registration can provide significant advantages to a party involved in a court proceeding. The USPTO cannot pro-

vide advice concerning rights in a mark. Only a private attorney can provide such advice.

Trademark rights can last indefinitely if the owner continues to use the mark to identify its goods or services. The term of a federal trademark registration is ten years, with ten-year renewal terms. However, between the fifth and sixth year after the date of initial registration, the registrant must file an official paper giving certain information to keep the registration alive. The registration is canceled if this is not done. Confirm specific trademark details and requirements with the USPTO.

### ONCE IS ALWAYS ENOUGH WITH CADD

by Karen Miller, Graphic Specialist, Tektronix, Inc.

Reusability is one of the important advantages of CADD. With CADD, it is never necessary to draw anything more than once. Developing a CADD symbols library further enhances the ability to reuse content. Building a parts library for reusability has increased productivity, decreased development costs, and set the highest standards for quality at the Test and Measurement Documentation Group at Tektronix, Inc. The parts library began by reusing 3-D isometric parts created by the CADD illustrator and saved

as symbols in a parts library directory. By pathing the named symbols back to this library directory, each symbol becomes accessible to any directory and drawing file. This allows the CADD illustrator to insert library symbols into any drawing by selecting named symbols from the directory.

The illustrator adds new parts to the library as a product is disassembled and illustrated. Each part is given the next available number as its symbol name in the library as shown in Figure 1.33.

Originally, the CADD drawings were combined with text (written using Microsoft Word) in desktop-publishing software to create technical publications. Now, the CADD

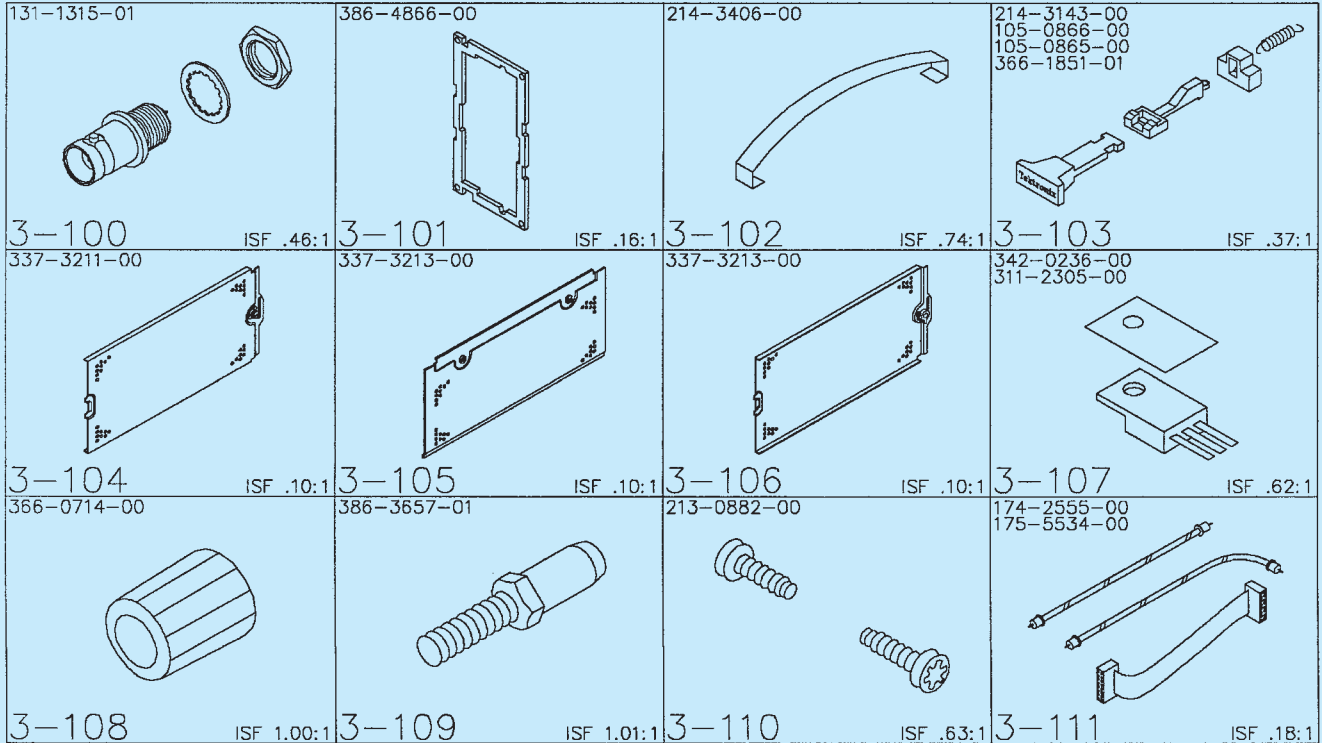


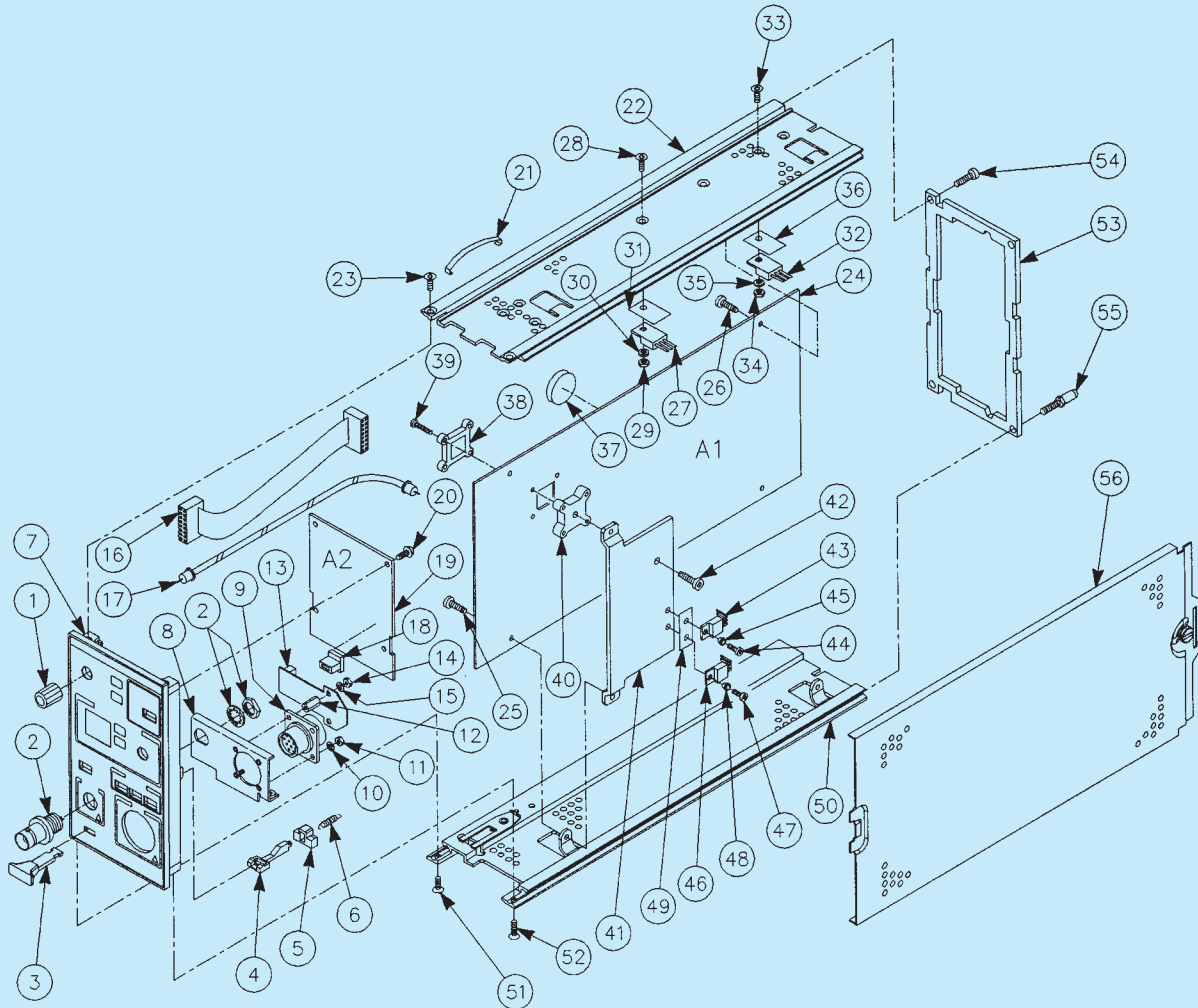
FIGURE 1.33 CADD parts library. Courtesy Karen Miller, Graphics Specialist, Tektronix, Inc.

(Continued)



drawings are added to document files in specialized technical-publishing software. The entire parts library is available to both CADD and technical-publication software users (see Figure 1.34).

From the point of view of cost management, the parts library has saved hundreds of hours of work. From the illustrator's view, the parts library helps improve productivity and frees time for new or complex projects.



**FIGURE 1.34** Integrating the parts from the library for a complete exploded assembly drawing. Tektronix current probe amplifier. Courtesy Karen Miller, Graphics Specialist, Tektronix, Inc.

## PROFESSIONAL PERSPECTIVE

### 15 FACTS OF THE PROFESSION

*By Olen K. Parker, Executive Director and Corporate Operations Officer, ADDA International*

There is a great difference between an individual trained in the theories, principles, standards, and requirements of the career field and a true professional. Being a professional is more than

holding a credential. A certificate or diploma is only an indication of knowledge in the area you have chosen to study. Many recently educated people search for a large salary, but they generally have only a moderate understanding of their career field and little or no training as a true professional.

The facts are simple. When employed, you typically sign an agreement indicating job requirements, work times, vacations, sick days, insurance provisions, and employer expectations.

Many employers have a dress code, a code of ethics, and other provisions you must follow. As an employee, you are an adult who is being paid to make things happen. You are a part in a working machine, but you are not the main wheel that makes it turn. Do your job, do it well, and keep the wheels turning, which is your primary function in an entry-level position.

In becoming a true professional, you need to keep in mind that with the availability of the Internet and other media, that your potential employer can check up on you and in many cases find out more than you want them to know. Facebook, MySpace, blogs, and other social networking areas on the Internet can be very damaging to your career if used improperly. As with your professional attitude, you need to keep some things private.

You do need a professional network, and there are many of them such as LinkedIn or Plaxo that can help you network on a professional level. Now is the time to exhibit responsibilities to yourself and your employer.

In my current role, I am in constant contact with the leaders of industry, representing some of the most prestigious manufacturing, engineering, architectural, and industrial firms in the world. When discussing employment of future drafters and designers, I often request information on the reasons one individual is chosen over another when they are equally qualified. The answer is consistent; they employ those who reflect professionalism in all aspects of their individuality and areas of training. The following are 15 facts that make you a professional:

1. You must understand that your education begins after you have achieved your training. Your credentials only expose you to the knowledge and skills needed to perform the job. Real education comes from day-to-day experience over many years.
2. Consider the interview process, the interviewer, and the type of company when seeking employment. Investigate the company and determine what they do, their geographic area, and who owns the company. The company mission and employee expectations should match your goals and objectives.
3. If you are seeking a career, do not take a job just to be employed. Dissatisfaction may show in your work and performance, and it may result in you seeking new employment or being terminated. Employment changes can make it difficult to becoming reemployed. You should always keep a position for two or more years.
4. Leave your attitude at home. You should show gratitude for your employment. Be proud that this company thinks you have the potential to be a part of its working family. Keep in mind that you are not the owner.
5. Keep your opinion to yourself, focus on your job, and shape your performance. This will bring you more attention and give you greater opportunities. Share improvement ideas with your supervisor. Ask if your work is acceptable and if there is anything that you can do better. Accept criticism with modesty.
6. Many co-workers will do anything to advance, which is an unethical fact of survival in the workplace. This activity can lead to discontent. Remember, you work for your supervisor, your job is to improve the product, produce a product, and increase company profits. Negative actions toward you by co-workers reflect their own inability to carry out their duties.
7. Acting professional is a big part of your new position. You hold credentials, and with them come a code of ethics that professionals follow. Here are some guidelines:
  - Be at your workstation, computer turned on, chair adjusted, and ready to work a few minutes before work time.
  - Take your breaks at the designated time. This is when you typically go to the restroom, get a coffee refill, or eat a snack. Work time is for production.
  - Your scheduled lunchtime includes travel. You may find it more convenient to eat at work and have time to relax or do personal things.
  - Quitting time can be exciting, but do not stop early just to be out the door at 5 P.M. sharp. Complete a project and then deliver it to your supervisor if it takes a few minutes longer. You will have a head start on tomorrow and your career.
8. Dress well for your interview and on the job, providing a professional appearance. Men should wear a shirt and tie, jacket, dress pants, and polished leather shoes with laces. Women should wear professional style clothing, fitting to the employment atmosphere. Women should avoid wearing dresses for the interview. Women should wear dress pants or a skirt, blouse, and matching jacket, or a pants suit, and avoid necklines more than four fingers below the high point of your sternum. Patent leather or athletic shoes should not be worn by either sex. Shoes should coordinate with your clothing and should be flats or low heels. Avoid noisy shoes. Wear professional color such as navy, black, or gray. Do not wear a white, yellow, or chartreuse jacket. Your shirt or blouse should be white, light blue, or a pastel color. Men should wear a tie that coordinates with the jacket and pants and wear a belt that matches shoe color.

In today's liberal work force, unisex clothing is readily available, and some of it looks sharp. However, in the interview process, make sure your clothing is cut to fit your body style. Accessories should be moderate, with no visible necklaces or dangling earrings. Cologne and perfume should be very subdued. For men and women, exposed body piercings in your nose, lips, and tongues and multiple sets of earrings should not be worn at the interview.

Personal choices should be used on personal time or when found to be acceptable. Otherwise, you could jeopardize your employment opportunity. Keep in mind you are applying for a job, and you do not know the preference of the company or the interviewer. The company makes the rules. Do not try to change policy if you want to keep your place. Observe the company dress code, so you know how to dress when you are employed.

As a new hire, you should dress conservatively even if you see others are wearing jeans and polo shirts. If everyone wears shirts and ties, you do the same and make sure you have a jacket. Having a jacket or sport coat is good in case you need to attend a meeting. If the job requires you to go to manufacturing or to the field, you should have an appropriate change of clothes or cover up. Finally, regardless of the dress code, keep a change of clothes in your car and be ready for an emergency dress up or dress down in a few minutes.

9. Self-improvement is a good investment on the job. Research on work, processes, clients, and other project-related issues while on your own time. This can improve your production, broaden your mind, discover new project ideas, find software solutions and production methods, or network with other professionals.
10. Most employment communication is proprietary and should not be discussed with anyone other than your supervisor or involved co-workers. Do not take information from work to home, unless approved by your supervisor.
11. Write personal e-mails and make personal phone calls after work or on your personal cell phone outside the office during break or at lunch. Using company equipment and company time is only for company business.
12. After employment, you need to start preparing for your next move up the career ladder. Your employer may offer educational benefits. If you have access to the Internet at home, you can do webinars and take online training and technical training or expand your formal education. Your new knowledge, ability to speak on technical subjects, and performance at work indicate your improvement without bragging. Provide information about your expanded learning during your annual reviews.
13. Completion of your education is only one step in the overall progression of your career track. You should seek industry certification with a professional organization. Certification is based on industry standards and required knowledge at a specific level in the profession, and it is offered by industry organizations who are experts in the field. Certification competencies provide minimum performance and knowledge levels to your employer. Certifications can be related to software, codes, standards, technical writing, and other subjects. Additional training reinforces your abilities and your employability.
14. Keep a work journal as an organizational tool and to improve your growth as a professional. Include specific assignment information, assignment performance, individuals involved, specific times and places related to the assignment, when you go to lunch, change projects, talk to a co-worker about a previous project, or attend a meeting about a new project. Entries made by time and date will stand firm in a challenge. The more you document the better.
15. While in school and after, you should be a member of any professional organization that relates to your profession. ADDA and Skills USA offer student memberships for the drafting profession. By being involved in professional associations, you will find a network of professionals who can assist you in every phase of your career path and offer opportunities, advice, and guidance you cannot receive anywhere else. As you leave your school and enter the workforce, you should retain your membership in the professional organization and become as active as possible.
 

Most organizations provide you with professionally rewarding volunteer opportunities on committees and groups to assist the profession. As you gain experience, you will see yourself working on projects with little assistance, moving up the corporate steps, being given more responsibility and increased compensation, and having opportunities you hoped for when you were first employed.

As you read this, you may wonder how this person can give advice. These steps are part of my career path. I was fortunate to work for one of the top 500 engineering and construction firms in the United States for 23 years. I started as a **tracer**, duplicating details and sections to drawings. The combination of my education and my mentor were two factors that made me a professional. While working for this firm, I was encouraged to become involved in professional organizations and continue my education in every area related to my position. The items you just read were a portion of what allowed me to move up the corporate ladder, becoming a professional drafter, detailer, chief drafter, and graphic arts director. I became involved in a professional organization, was appointed to the board of directors, appointed chair of several committees, was elected secretary, vice president, and president. These accomplishments gave me great pleasure, allowing me to guide future professionals who would take my place. You should take advantage of opportunities and create your own path to reach goals in your career. My name is Olen Parker, Executive Director and Corporate Operations Officer for the American Design Drafting Association and the American Digital Design Association (ADDA International). I have the greatest and most satisfying job in the world. The ADDA staff, board of directors, and governors assist thousands of students and professionals reach new goals in their careers every year. My vision

is simple: If I can make one person have a better life, by helping in his or her career or by designing a better product or home, then I have succeeded.

Take the advice of mature professionals and always seek to improve who you are and what you do. Your name and reputation will be handed to your children and your children's children. You have a career opportunity to leave a legacy by designing a building, an improved product, or an innovation that can change the world. We are the drafters and designers, the backbone of the engineering and architectural process. We make ideas become reality. We can draw and make any idea buildable.

The following summarizes our profession: **Drafting** is the foundation and stepping-stone of any aspiring architect and engineer. It is a tedious profession, with days filled with non-stop drawing and making models of designs. It is through this process that one is able to learn to develop new skills and be introduced to styles that can be used as inspiration for personal design preferences in the future. Drafting molds the builders and designers of the future. Drafting is the profession of the hardworking and the persevering, the patient and the creative, the ambitious and the proud.

SOURCE: Student Exchange of Spain and Abroad.

## WEB SITE RESEARCH

Use the following Web sites as a resource to help find more information related to engineering drawing and design and the content of this chapter.

Address	Company, Product, or Service
online.onetcenter.org	Occupational Information Network (O*NET), United States Department of Labor, Employment and Training Administration
www.adda.org	American Design Drafting Association and American Digital Design Association (ADDA International)
www.aia.org	American Institute of Architects (AIA)
www.amazon.com	Search for employment preparation books such as <i>Resumes for Dummies</i> , <i>Cover Letters for Dummies</i> , and <i>Job Interviews for Dummies</i> .
www.asme.org	American Society of Mechanical Engineers (ASME)
www.aws.org	American Welding Society (AWS)
www.bestjobsusa.com	Best Jobs USA
www.bls.gov/oco	<i>Occupational Outlook Handbook</i> , United States Department of Labor, Bureau of Labor Statistics
www.bls.gov/soc	<i>Standard Occupational Classification</i> , United States Department of Labor, Bureau of Labor Statistics
www.buildingsmartalliance.org/ncs/	United States National CAD Standard (NCS)
www.careerbuilder.com	Career Builder
www.careermag.com	CAREER magazine
www.careermosaic.com	Career Mosaic
www.careerpath.com	Career Path
www.careers.org	Careers
www.copyright.gov	Library of Congress, United States Copyright Office
www.dbm.com	The Riley Guide: Employment Opportunities and Job Resources on the Internet
www.dol.gov	United States Department of Labor
www.espan.net	E-Span Interactive Employment Network
www.iso.org	International Standards Organization (ISO)
www.jobbankinfo.org	America's Job Bank
www.jobweb.com	Jobweb
www.monster.com	Find jobs, post a résumé, network, and get advice
www.nacfam.org	National Coalition for Advanced Manufacturing (NACFAM)
www.usjobnet.com	United States Job Net
www.uspto.gov	United States Department of Commerce, United States Patent and Trademark Office (USPTO)

## Chapter 1 Introduction to Engineering Drawing and Design Test



To access the Chapter 1 test, go to the Student CD, select **Chapter Tests and Problems**, and then **Chapter 1**. Answer the questions

with short, complete statements, sketches, or drawings as needed. Confirm the preferred submittal process with your instructor.

## Chapter 1 Introduction to Engineering Drawing and Design Problems

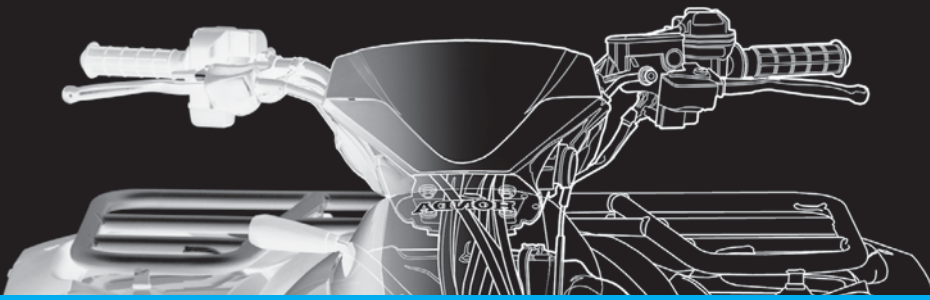
### INSTRUCTIONS

Select one or more of the following problem topic areas as determined by your instructor or course guidelines and write a 300- to 500-word report on the selected topic or topics. Prepare each report using a word processor. Use double spacing, proper grammar and spelling, and illustrative examples where appropriate. Use, but do not copy, the information found in this chapter and additional research information.

#### Problems 1.1 Through 1.20

- PROBLEM 1.1** Importance of engineering drawing and design for manufacturing and construction.
- PROBLEM 1.2** History of drafting.
- PROBLEM 1.3** Computers in design and drafting.
- PROBLEM 1.4** One or more drafting fields of your choice.
- PROBLEM 1.5** Requirements for becoming a drafter.
- PROBLEM 1.6** Searching for a drafting position.
- PROBLEM 1.7** Employment opportunities on the Internet.

- PROBLEM 1.8** American Design Drafting Association and American Digital Design Association (ADDA).
- PROBLEM 1.9** ASME drafting standards.
- PROBLEM 1.10** ISO drafting standards.
- PROBLEM 1.11** United States National CAD Standard.
- PROBLEM 1.12** Workplace ethics.
- PROBLEM 1.13** Intellectual property rights.
- PROBLEM 1.14** Software piracy.
- PROBLEM 1.15** Copyrights.
- PROBLEM 1.16** Patents.
- PROBLEM 1.17** Trademarks.
- PROBLEM 1.18** It is never necessary to draw anything more than once with CADD.
- PROBLEM 1.19** Professional perspective.
- PROBLEM 1.20** Your own selected topic that relates to the content of this chapter.



# CHAPTER 2

## Drafting Equipment, Media, and Reproduction Methods

### LEARNING OBJECTIVES

After completing this chapter, you will:

- Describe and demonstrate the use of manual drafting equipment and supplies.
- Explain the concept of drawing scale, and identify common inch and metric scales.
- Read metric, civil engineer, architect, and mechanical scales.
- Describe and use drafting media, sheet sizes, and sheet blocks and symbols.
- Explain common drawing-reproduction methods.

## THE ENGINEERING DESIGN APPLICATION

The overall success of any project begins with the layout and planning stage. Proper and thorough planning is a key to ensuring the project runs efficiently and produces drawings, designs, and products that are accurate, consistent, and well made. Therefore, it is vital that you are familiar with the **drawing planning process** so you can apply it to any type of drawing or project in any drawing and design discipline. Avoid the temptation to begin working on a new design, drawing, or model without having a plan. Instead, take time to plan the drawing process sufficiently using the outline given here. The project-planning process is an important aspect of solving any problem or working on any type of project.

### The Problem-Solving Process

A three-step process allows you to organize your thoughts, ideas, and knowledge about a project immediately. Prior to beginning the three-step process, carefully read all instructions available for the project. The project-planning process requires you or the workgroup to answer the following three questions about the project:

1. What do you know about the subject?
2. What do you need to know about the subject?
3. Where can you find the information you need?

The best way to answer these questions is to use **brainstorming**. Brainstorming is a problem-solving method that allows individuals to voice their thoughts and ideas regarding the specific topic, problem, or project at

hand. Here are a few suggestions for working in a brainstorming session.

- One person records all statements.
- Place a reasonable time limit on the session, or agree to let the session run until all ideas are exhausted.
- Every statement, idea, or suggestion is a good one.
- Do not discuss, criticize, or evaluate any statement or suggestion.

Return to the brainstorming list later to evaluate the items. Throw out items that the group agrees are not valid. Rank the remaining ideas in order of importance or validity. Now you are ready to conduct research and gather information required to begin and complete the project.

### Research Techniques

Use any available techniques to research the requirements for a project. The Internet is an inviting and effective method of conducting research, but it can also be time consuming and nonproductive if you do not use it in a logical manner. You should still know how to use traditional resources such as libraries, print media, and professional experts in the area of your study. Conduct any research using a simple process to find information efficiently.

- Define and list your topic, project, or problem.
- Identify keywords related to the topic.

- Identify all resources with which you are familiar that can provide information.
- Use the Internet to conduct quick keyword searches on the topic.
- Check with libraries for lists of professional indexes, periodicals and journals, specialized trade journals, and reference books related to specialized topics.
- Contact schools, companies, and organizations in your local area to find persons who are knowledgeable in the field of your research.
- Create a list of all potential resources.
- Prioritize the list and focus first on the most likely resource to provide the information you need.
- Begin your detailed study of the prioritized list.
- Ask questions.

### Preparing a Drawing

After planning the drawing project as previously outlined, establish a method for starting and completing the actual drawing. Always begin any drawing or design project with freehand sketches. Use the following basic procedure:

- Create a freehand sketch of the intended drawing layout showing all views, sections, details, and pictorials. Apply all required dimensions and notes. Use numbered items or colored pencils to label or list the components in the order they are to be drawn.
- Try to determine if special views are required.

- Note the geometric shapes that you must draw from scratch.
- Determine if you can edit existing shapes to create new features.
- Find existing objects that you can insert or reference in the drawing.
- Determine the locations and required type of dimensions.
- Locate all local notes, general notes, and view titles.
- Try to decide if using object values such as size, location, and areas can assist you in drawing additional features or can provide useful information required for the project.
- Determine the types of prints and plots or electronic images that are required for the project.
- Begin work on the project.

It may seem to the beginning drafter that these project-planning procedures are an unnecessary amount of work just to plan a drawing or project. However, keep in mind that if you do not take the time at the beginning to plan and gather the information you need, then you will have to do so at some time during the project. It is better to begin a project from a solid foundation of plans and information than to interrupt your work at any stage of the project to find the information you need. If you make the project-planning process a regular part of your work habits, then any type of engineering design process you encounter is easier.

## INTRODUCTION

This chapter explains and demonstrates the type of equipment and supplies used for manual drafting. **Manual drafting**, also known as **hand drafting**, describes traditional drafting practice using pencil or ink on a medium such as paper or polyester film, with the support of drafting instruments and equipment. This chapter also explains drawing scale, sheet size, and sheet format.

Computer-aided design and drafting (CADD) has replaced manual drafting in most of the drafting industry. As a result, some of the information in this chapter primarily serves as a historical reference. Chapters 3 and 4 of this textbook describe CADD in detail and explore the reasons for the evolution of drafting from manual drafting to CADD. However, both manual drafting and CADD require that you understand the basics of drafting. Concepts such as scale, sheet size, and sheet format are critical and universal to manual drafting and CADD. In addition, some companies use CADD but have manual drafting equipment available that you should be able to recognize and operate at a basic level (see Figure 2.1).



**FIGURE 2.1** An engineering office with computer workstations and a manual drafting table in use. © Caro/Alamy

## MANUAL DRAFTING EQUIPMENT AND SUPPLIES

Professional manual drafting requires appropriate drafting equipment and supplies. If you work in a modern CADD environment, manual drafting tools such as compasses, dividers, triangles, templates, and scales have less importance but are still valuable for sketching, taking measurements, and other related activities. You can purchase drafting supplies and equipment in a kit or buy items individually. Manual drafting equipment is available from many local and on-line vendors. Search the Internet or a phone book for keywords or headings such as *drafting equipment and supplies*, *blue printing*, *architect supplies*, and *artist supplies*. Always purchase quality instruments for the best results. The following is a list of items normally needed for typical manual drafting:

- Drafting furniture.
- One 0.3 mm automatic drafting pencil with 4H, 2H, and H leads.
- One 0.5 mm automatic drafting pencil with 4H, 2H, H, and F leads.
- One 0.7 mm automatic drafting pencil with 2H, H, and F leads.
- One 0.9 mm automatic drafting pencil with H, F, and HB leads.
- Sandpaper sharpening pad.
- Erasers recommended for drafting with pencil on paper.
- Erasing shield.
- Dusting brush.
- 6 in. bow compass.
- Dividers.
- 8 in. 30°–60° triangle.
- 8 in. 45° triangle.
- Circle template with small circles.
- Circle template with large circles.
- Irregular curve.
- Scales:
  - Triangular architect's scale.
  - Triangular civil engineer's scale.
  - Triangular metric scale.
- Drafting tape.
- Lettering guide (optional).
- Arrowhead template (optional).



**NOTE:** Cleaning drafting equipment each day helps keep your drawing clean and free of smudges. Use a mild soap and water or a soft rag or tissue to clean drafting equipment. Avoid using harsh

cleansers or products that are not recommended for use on plastic. It is also a good practice to clean your hands periodically to remove graphite and oil. Also, keep your hands dry.

## DRAFTING FURNITURE



### Drafting Furniture

For information about special tables and chairs required for manual drafting, go to the Student CD, select **Supplemental Material, Chapter 2**, and then **Drafting Furniture**.

## DRAFTING PENCILS AND LEADS

Automatic pencils are common for manual drafting, sketching, and other office uses. The term **automatic pencil** refers to a pencil with a lead chamber that advances the lead from the chamber to the writing tip by the push of a button or tab when a new piece of lead is needed (see Figure 2.2). Automatic pencils hold leads of one width so you do not need to sharpen the lead. The pencils are available in several different lead sizes. Drafters typically have several automatic pencils. Each pencil has a different grade of lead hardness and is appropriate for a specific technique. This reduces the need to change leads constantly. Some drafters use a light blue lead for layout work. If your primary work is CADD, a combination of 0.5-, 0.7-, and 0.9 mm pencils and leads is good for sketching and related activities.

### Lead Grades

Lead grades of 2H and H are good in your automatic pencil for typical daily office use. The leads you select for line work and lettering depend on the amount of pressure you apply and other technique factors. Experiment until you identify the leads that give the best line quality. Leads commonly used for thick lines range from 2H to F, whereas leads for thin lines range from 4H to H, depending on individual preference. Construction lines for layout and guidelines are very lightly drawn with a 6H or 4H lead. Figure 2.3 shows the different lead grades.



**FIGURE 2.2** An automatic pencil. Lead widths are 0.3, 0.5, 0.7, and 0.9 mm. Courtesy Koh-I-Noor, Inc.



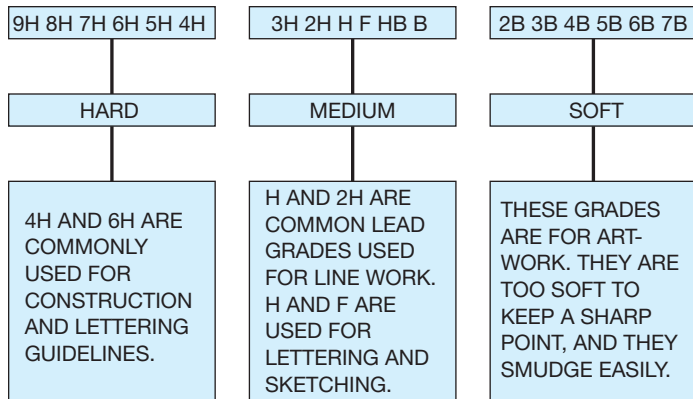


FIGURE 2.3 The range of lead grades. © Cengage Learning 2012

### Other Pencils and Pencil Techniques

**Other Pencils and Pencil Techniques**

For information about mechanical pencils, polyester and specialty leads, and pencil techniques and sharpening for manual drafting, go to the Student CD, select **Supplemental Material, Chapter 2**, and then **Other Pencils and Pencil Techniques**.

### TECHNICAL PENS, PEN CLEANING, AND INK

**Technical Pens, Pen Cleaning, and Ink**

For information about inked line equipment for manual drafting, go to the Student CD, select **Supplemental Material, Chapter 2**, and then **Technical Pens, Pen Cleaning, and Ink**.

### ERASERS AND ERASING

**Erasers and Erasing**

For information about erasers and using erasers for manual drafting, go to the Student CD, select **Supplemental Material, Chapter 2**, and then **Erasers and Erasing**.

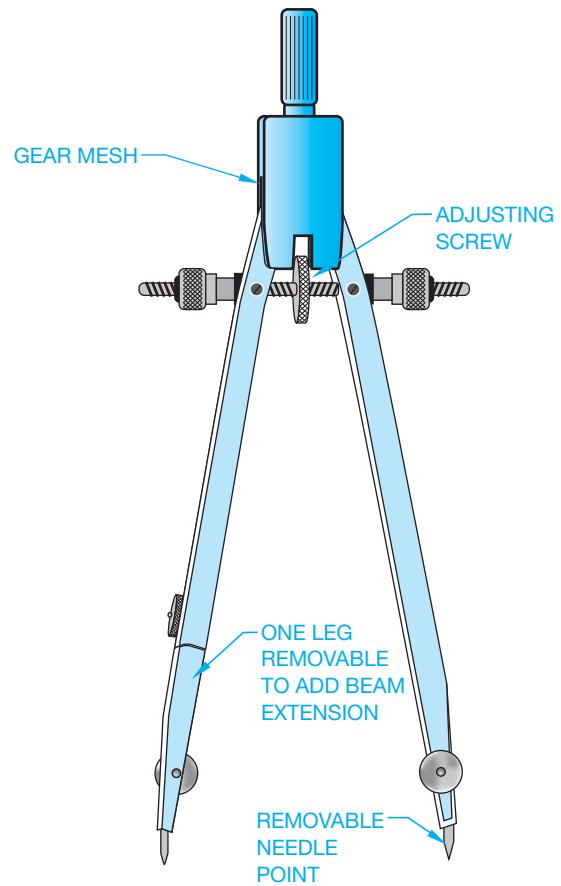


FIGURE 2.4 Bow compass.

© Cengage Learning 2012

### Compasses

A **compass** is an instrument used to draw circles and arcs. A compass is especially useful for large circles, but using one can be time consuming. Use a template, whenever possible, to make circles or arcs more quickly.

There are several basic types of compasses. A **bow compass**, shown in Figure 2.4, is used for most drawing applications. A **beam compass** consists of a bar with an adjustable needle, and a pencil or pen attachment for swinging large arcs or circles. Also available is a beam that is adaptable to the bow compass. This adapter works only on a bow compass that has a removable leg.

**Using a Compass**

For information about properly using a compass for manual drafting, go to the Student CD, select **Supplemental Material, Chapter 2**, and then **Using a Compass**.

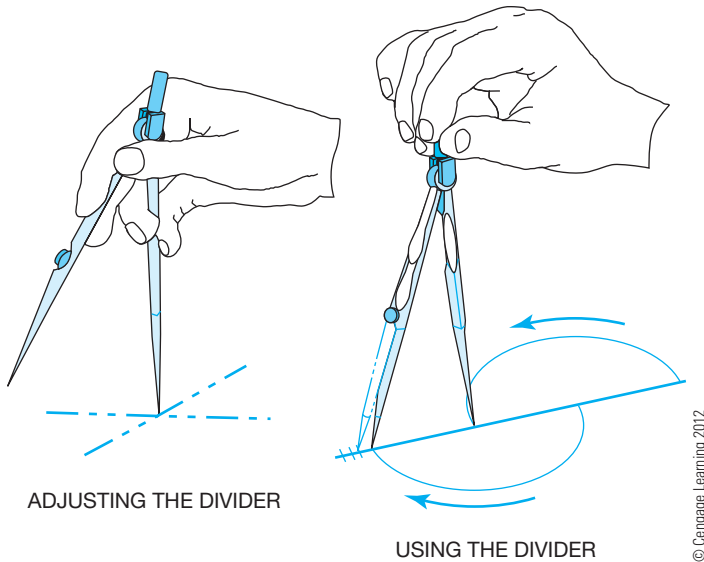


FIGURE 2.5 Using a divider.

### DIVIDERS

**Dividers** are used to transfer dimensions or to divide a distance into a number of equal parts. Dividers are also used in navigation to measure distance in nautical miles. Some drafters prefer to use **bow dividers** because the center wheel provides the ability to make fine adjustments easily. In addition, the setting remains more stable than with standard friction dividers.

A good divider should not be too loose or tight. It should be easy to adjust with one hand. You should always control a divider with one hand as you lay out equal increments or transfer dimensions from one feature to another. Do not try to use a divider as a compass. Figure 2.5 shows how to handle the divider when used.

### Proportional Dividers

**Proportional dividers** are used to reduce or enlarge an object without having to make mathematical calculations or scale manipulations. The center point of the divider is set at the correct point for the proportion you want. Then you measure the original size line with one side of the proportional divider; the other side automatically determines the new reduced or enlarged size.

### PARALLEL BAR

The **parallel bar** slides up and down a drafting board to allow you to draw horizontal lines. (See Figure 2.6.) Use triangles with the parallel bar to draw vertical lines and angles. The parallel bar was common for architectural drafting because architectural drawings are frequently very large. Architects using manual drafting often need to draw straight lines the full length of their boards, and the parallel bar is ideal for such lines.

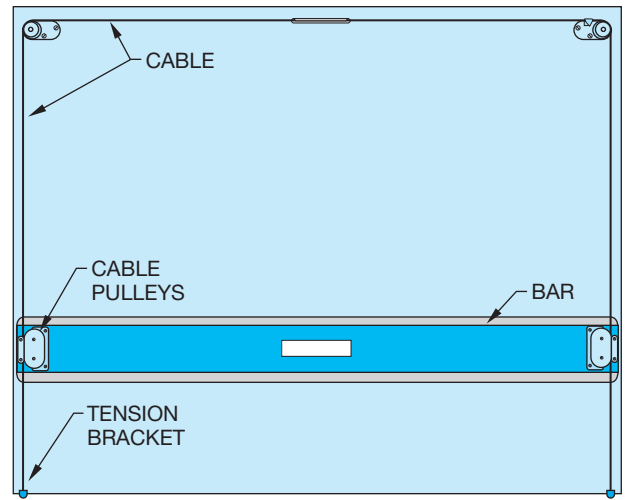


FIGURE 2.6 Parallel bar.

### TRIANGLES

There are two standard triangles. The 30°–60° triangle has angles of 30°–60°–90°. The 45° triangle has angles of 45°–45°–90° (see Figure 2.7). Some drafters prefer to use triangles in place of a vertical drafting machine scale as shown in Figure 2.8. Use the machine protractor or the triangle to make angled lines. Using parallel bars, drafters utilize triangles to make vertical and angled lines.

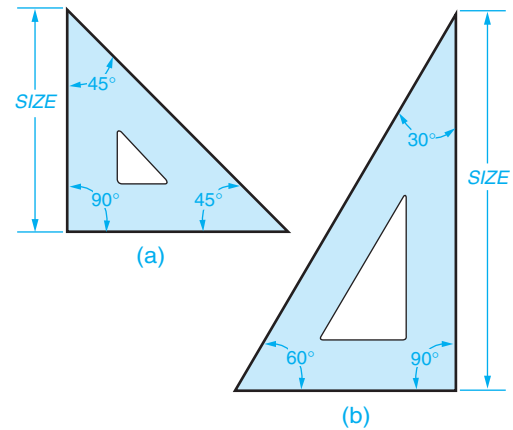


FIGURE 2.7 (a) 45° triangle. (b) 30°–60° triangle.

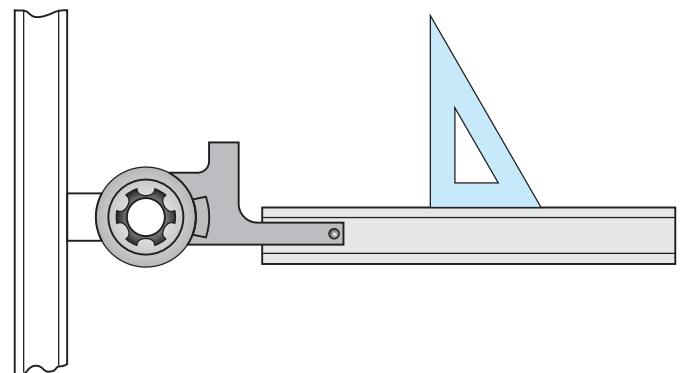


FIGURE 2.8 Using a triangle with a drafting machine.  
© Cengage Learning 2012

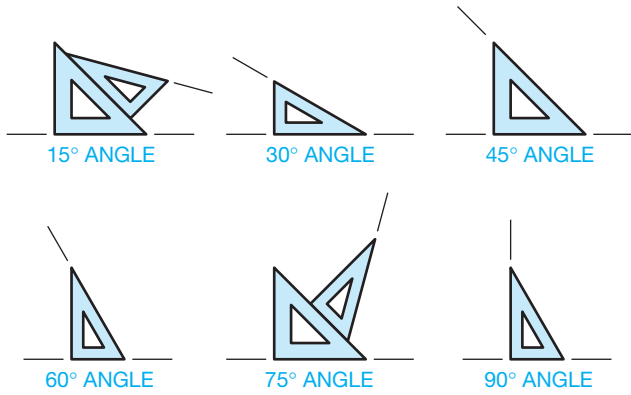


FIGURE 2.9 Angles that may be made with the 30°–60° and 45° triangles individually or in combination.

Triangles can also be used as straightedges to connect points for drawing lines without the aid of a parallel bar or machine scale. Use triangles individually or in combination to draw angled lines in 15° increments (see Figure 2.9). Also available are adjustable triangles with built-in protractors that are used to make angles of any degree up to a 45° angle.

### TEMPLATES

Manual drafting templates are plastic sheets with accurate shapes cut out for use as stencils to draw specific shapes. The most common manual drafting templates are circle templates for drawing circles and arcs. Templates for drawing other shapes, such as ellipses, and for letters are also common. Templates are also available for specific requirements and drafting disciplines. For example, use architectural templates to draw floor plan and other symbols to scale. Electronic drafting templates have schematic symbols for electronic schematic drawings.

#### Circle Templates

Circle templates are available with circles in a range of sizes beginning with 1/16 in. (1.5 mm). The circles on the template are marked with their diameters and are available in fractions, decimals, or millimeters. Figure 2.10 shows the parts of a circle. Figure 2.11 shows examples of circle templates. A popular template is one that has circles, hexagons, squares, and triangles.

Always use a circle template rather than a compass. Circle templates save time and are very accurate. For best results when

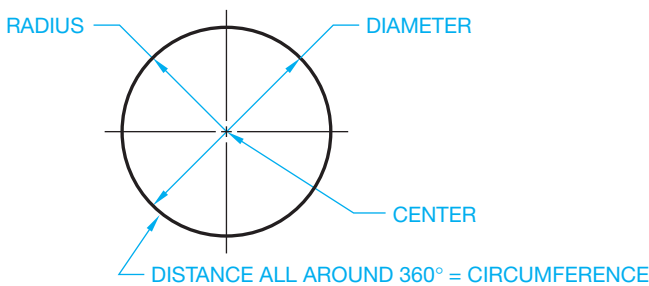


FIGURE 2.10 Parts of a circle.

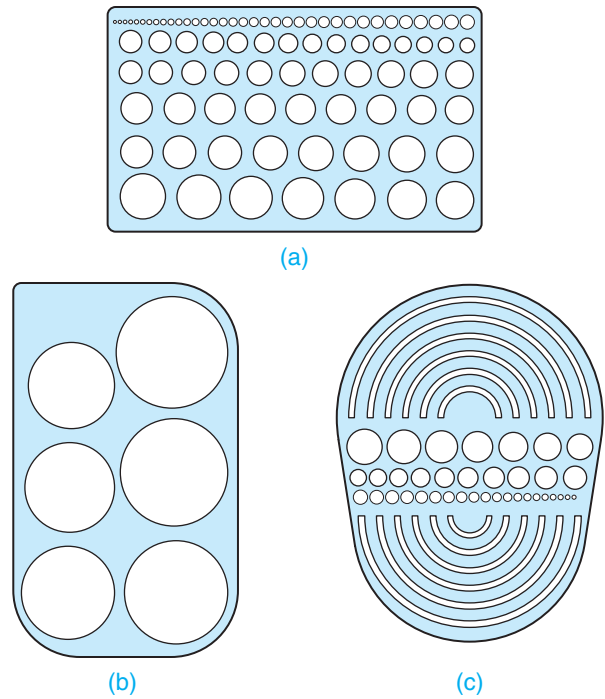


FIGURE 2.11 Circle templates. (a) Small circles. (b) Large, full circles. (c) Large half circles.

making circles, keep your pencil or pen perpendicular to the paper. To obtain proper width lines with a pencil, use a 0.9 mm automatic pencil.

#### Ellipse Templates

An ellipse is a circle seen at an angle. Figure 2.12 shows the parts of an ellipse. The type of pictorial drawing known as isometric projects the sides of objects at a 30° angle in each direction away from the horizontal. Isometric circles are ellipses aligned with the horizontal right or left planes of an isometric box as shown in Figure 2.13. Isometric ellipse templates

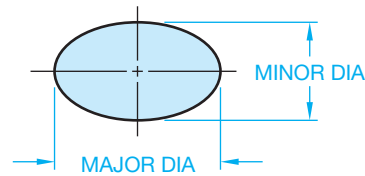


FIGURE 2.12 Parts of an ellipse.

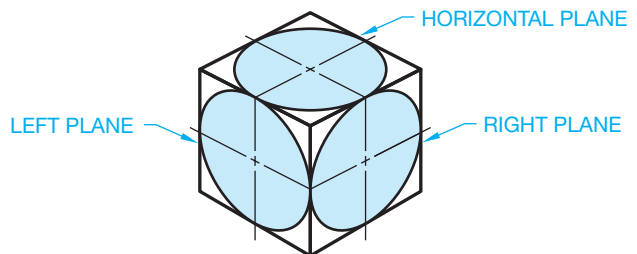
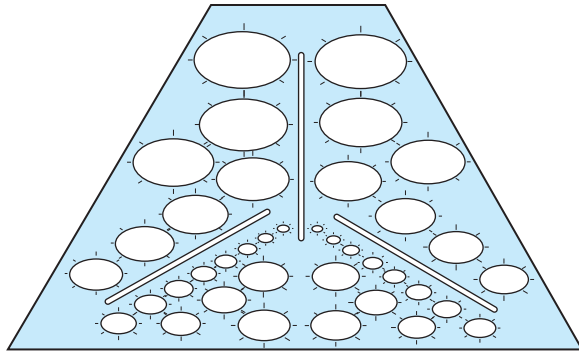


FIGURE 2.13 Ellipses in isometric planes.



© Cengage Learning 2012

**FIGURE 2.14** Isometric ellipse template.

automatically position the ellipse at the proper angle of  $35^{\circ} 16'$  (see Figure 2.14). Chapter 5 of this textbook covers isometric sketching, and Chapter 15 explains isometric drawing in detail.

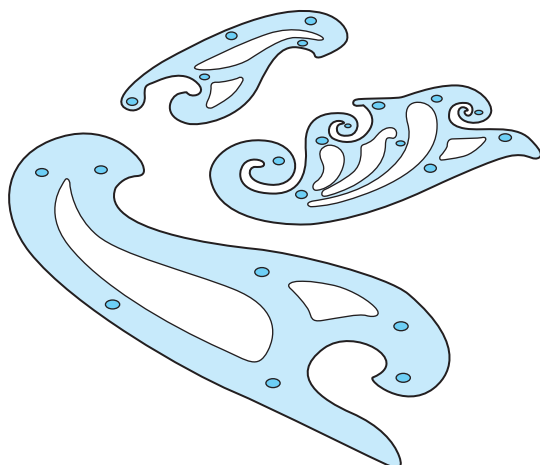


### Using Templates

For information about properly using manual drafting templates, go to the Student CD, select **Supplemental Material, Chapter 2**, and then **Using Templates**.

## IRREGULAR CURVES

**Irregular curves**, commonly called **French curves**, are curves that have no constant radii. Figure 2.15 shows common irregular curves. A radius curve is composed of a radius and a tangent. The radius on these curves is constant and ranges from 3 ft to 200 ft. (900–60,000 mm). Irregular curves are commonly used in highway drafting. Ship's curves are also available for layout and development of ships hulls. The curves in a set of ship's curves become progressively larger and, like French curves, have no constant radii. Flexible curves are also available that allow you to adjust to a desired curve.



Courtesy the C-Thru® Ruler Company

**FIGURE 2.15** Irregular curves also called *French curves*.



### Using Irregular Curves

For information about properly using irregular curves for manual drafting, go to the Student CD, select **Supplemental Material, Chapter 2**, and then **Using Irregular Curves**.

## DRAFTING MACHINES

A manual **drafting machine** is a machine that mounts to the table or board and has scales attached to an adjustable head that rotates for drawing angles. When locked in a zero position, the scales allow drawing horizontal and vertical lines and perpendicular lines at any angle orientation. The drafting machine vernier head allows you to measure angles accurately to 5' (minutes). Drafting machines, for the most part, take the place of triangles and parallel bars. The drafting machine maintains a horizontal and vertical relationship between scales, which also serve as straightedges. A protractor allows the scales to be set quickly at any angle.

There are two types of drafting machines: arm and track. The track machine generally replaced the arm machine in the history of manual drafting. A major advantage of the track machine is that it allows the drafter to work with a board in the vertical position. A vertical drafting surface position is generally more comfortable to use than a horizontal table. When ordering a drafting machine, the specifications should relate to the size of the drafting board on which it is mounted. For example, a  $37\frac{1}{2} \times 60$  in. (950–1500 mm) machine properly fits a table of the same size.

### Arm Drafting Machine

The arm drafting machine is compact and less expensive than a track machine. The arm machine clamps to a table and through an elbowlike arrangement of supports allows you to position the protractor head and scales anywhere on the board. Figure 2.16 shows an arm drafting machine.



**FIGURE 2.16** Arm drafting machine. *Vemco Drafting Prod Corp.*

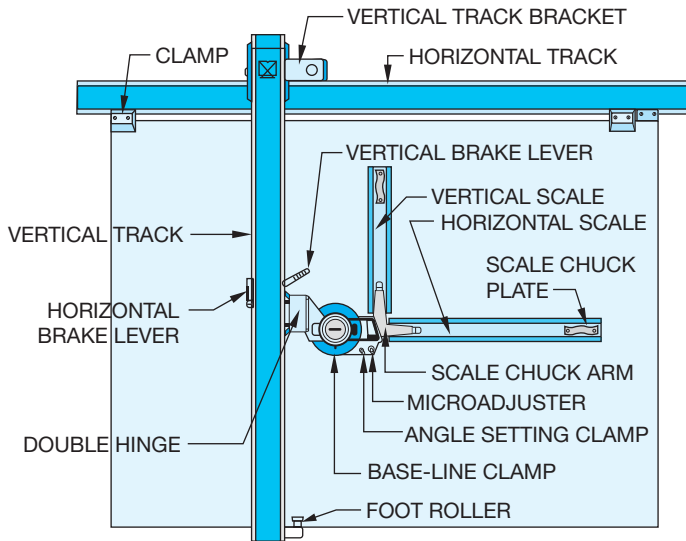


FIGURE 2.17 Track drafting machine and its parts. Courtesy Mutoh America, Inc.

## Track Drafting Machine

A track drafting machine has a traversing arm that moves left and right across the table and a head unit that moves up and down the traversing arm. There is a locking device for both the head and the traversing arm. The shape and placement of the controls of a track machine vary with the manufacturer, although most brands have the same operating features and procedures. Figure 2.17 shows the components of a track drafting machine.



### Drafting Machine Controls and Operation

For information about properly using drafting machines for manual drafting, go to the Student CD, select **Supplemental Material, Chapter 2**, and then **Drafting Machine Controls and Operation**.

## SCALES

A **scale** is an instrument with a system of ordered marks at fixed intervals used as a reference standard in measurement. A scale establishes a proportion used in determining the dimensional relationship of an actual object to the representation of the same object on a drawing. Use specific scales for mechanical, architectural, civil, and metric drawings.

Manual drafters use scales as measurement instruments to help create scaled drawings. In a CADD work environment, a scale is useful for sketching and taking measurements, as well as for related tasks. Scale is a universal and critical design and drafting concept. This chapter introduces the concept of scale and explains how to use scales and measurement instruments. You will learn more about scale and preparing scaled drawings throughout this textbook.

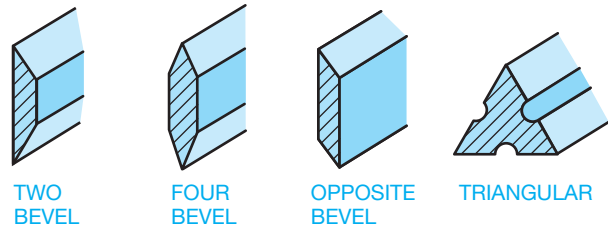


FIGURE 2.18 Scale shapes.

## Scale Shapes

There are four basic scale shapes, as shown in Figure 2.18. The two-bevel scale is also available with chuck plates for use with standard arm or track drafting machines. Drafting machine scales have typical calibrations, and some have no scale reading for use as a straightedge. Drafting machine scales are purchased by designating the length needed—12, 18, or 24 in.—and the scale calibration such as metric, engineer's full scale in tenths and half-scale in twentieths, or architect's scale  $1/4" = 1'-0"$ . Many other scales are available. The triangular scale is commonly used in drafting and has different scale calibrations on each corner of the triangle. Common triangular scales are the architectural scale calibrated in feet and inches, mechanical scale calibrated in decimal inches, civil scale calibrated in feet and tenths of a foot, and the metric scale calibrated in millimeters and centimeters.

## Drawing Scale

Drawings are scaled so that the objects represented can be illustrated clearly on standard sizes of paper. It would be difficult, for example, to make a full-size drawing of a house. You must decrease the displayed size, or scale, of the house to fit properly on a sheet. Another example is a very small machine part that requires you to increase the drawing scale to show necessary detail. Machine parts are often drawn full size or even two, four, or ten times larger than full size, depending on the actual size of the part.

The selected scale depends on:

- The actual size of the objects drawn.
- The amount of detail to show.
- The media size.
- The amount of dimensioning and notes required.

In addition, you should always select a standard scale that is appropriate for the drawing and drafting discipline. Avoid scales that are not identified in this chapter and throughout this textbook. The drawing title block usually indicates the scale at which most views are drawn or the predominant scale of a drawing. If the scale of a view differs from that given in the title block, the unique scale typically appears as a note below the corresponding view.

The following scales and their notations are common to mechanical drawings:

#### INCH SCALES

Full scale	= FULL or 1:1
Half scale	= HALF or 1:2
Quarter scale	= QUARTER or 1:4
Twice scale	= DOUBLE or 2:1
Four times scale	= 4:1
Ten times scale	= 10:1

#### METRIC SCALES

Full scale	= 1:1
Half scale	= 1:2
One fifth scale	= 1:5
One twenty-fifth scale	= 1:25
One thirty-three and one-third scale	= 1:33⅓
One seventy-fifth scale	= 1:75

The following scales are common to architectural drafting:

1/8" = 1'-0"	1" = 1'-0"
1/4" = 1'-0"	1 1/2" = 1'-0"
1/2" = 1'-0"	3" = 1'-0"

The following scales are common to civil drafting:

1" = 10'	1" = 50'
1" = 20'	1" = 60'
1" = 30'	1" = 100'

## Metric Scale

### STANDARDS

**ASME** According to the American Society of Mechanical Engineers (ASME) document ASME Y14.5-2009, *Dimensioning and Tolerancing*, the commonly used International System of Units (SI) linear unit used on engineering drawings is the millimeter (mm). The commonly used U.S. customary linear unit used on engineering drawings is the decimal inch (IN). For drawings in which all dimensions are in either inches or millimeters, individual identification of units is not required. All engineering drawings shall have a general note stating: UNLESS OTHERWISE SPECIFIED DIMENSIONS ARE IN INCHES (or MILLIMETERS as applicable). When some millimeters are shown on an inch-dimensioned drawing, the millimeter value should be followed by the abbreviation mm. Where some inches are shown on a millimeter-dimensioned drawing, the inch value should be followed by the abbreviation IN.

Metric symbols are as follows:

Millimeter	= mm
Centimeter	= cm
Decimeter	= dm
Meter	= m
Dekameter	= dam
Hectometer	= hm
Kilometer	= km

The following provides some metric-to-metric equivalents:

10 millimeters	= 1 centimeter
10 centimeters	= 1 decimeter
10 decimeters	= 1 meter
10 meters	= 1 dekameter
10 hectometers	= 1 kilometer

The following lists some metric-to-U.S.-customary equivalents:

1 millimeter	= .03937 inch
1 centimeter	= 3.937 inches
1 meter	= 9.37 inches
1 kilometer	= .6214 mile

The following lists some U.S.-customary-to-metric equivalents:

1 mile	= 1.6093 kilometers	= 1609.3 meters
1 yard	= 914.4 millimeters	= 0.9144 meter
1 foot	= 304.8 millimeters	= 0.3048 meter
1 inch	= 25.4 millimeters	= 0.254 meter



**NOTE:** To convert inches to millimeters, multiply inches by 25.4.

Figure 2.19 shows the common scale calibrations found on the triangular metric scale. One advantage of the metric scales is that any scale is a multiple of ten; therefore, any reductions or enlargements are easy to perform. No mathematical calculations should be required when using a metric scale. Always select a direct reading sale. To avoid error, do not multiply or divide metric scales by anything but multiples of ten.

## Civil Engineer's Scale

The triangular civil engineer's scale contains six scales, two on each of its sides. The civil engineer's scales are calibrated in multiples of ten. The scale margin displays the scale represented on a particular edge. The following table shows some of the many scale options available when using the civil engineer's scale. Keep in mind that *any* multiple of ten is available with the civil engineer's scale.

Civil Engineer's Scale					
Divisions	Ratio	Scales Used with This Division			
10	1:1	1" = 1"	1" = 1'	1" = 10'	1" = 100'
20	1:2	1" = 2"	1" = 2'	1" = 20'	1" = 200'
30	1:3	1" = 3"	1" = 3'	1" = 30'	1" = 300'
40	1:4	1" = 4"	1" = 4'	1" = 40'	1" = 400'
50	1:5	1" = 5"	1" = 5'	1" = 50'	1" = 500'
60	1:6	1" = 6"	1" = 6'	1" = 60'	1" = 600'

The 10 scale is often used in mechanical drafting as a full, decimal-inch scale (see Figure 2.20). Increments of 1/10 (.1) in. can easily be read on the 10 scale. Readings of less than .1 in. require you to approximate the desired amount, as shown in Figure 2.19. Scales are available that refine the increments to 1/50th of an inch

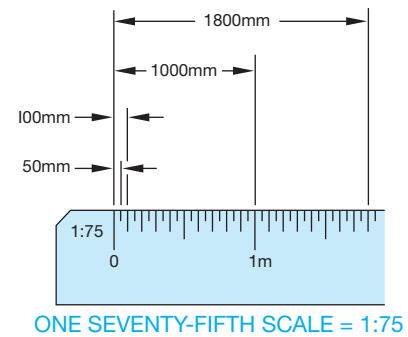
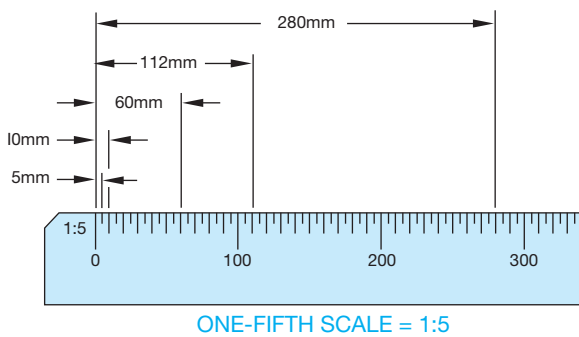
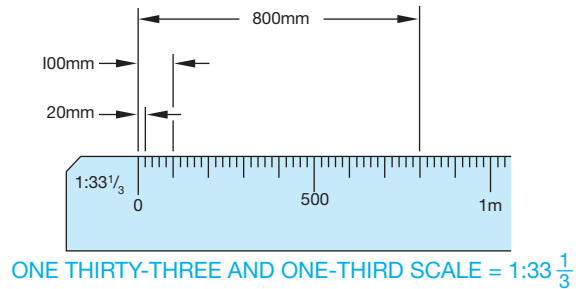
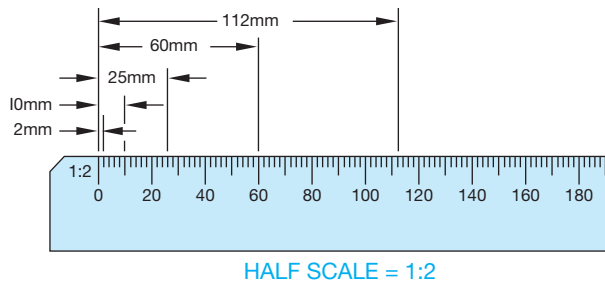
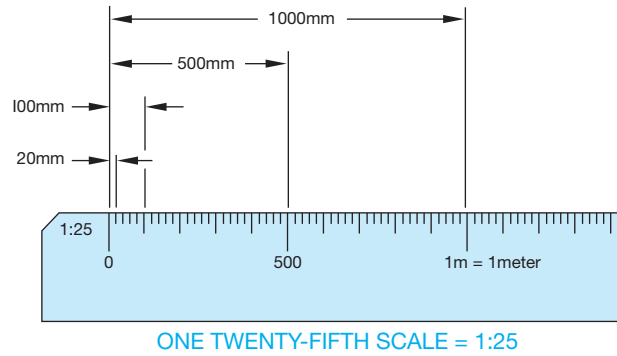
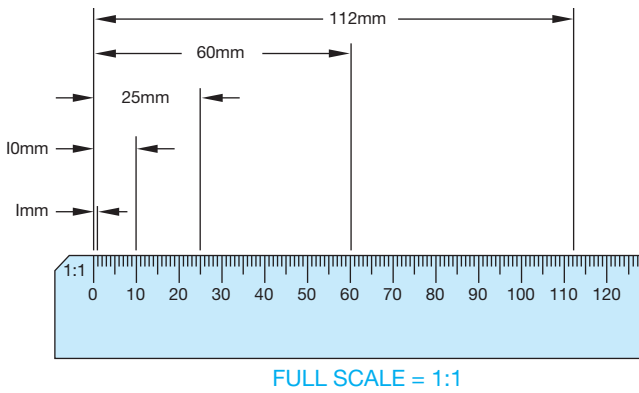
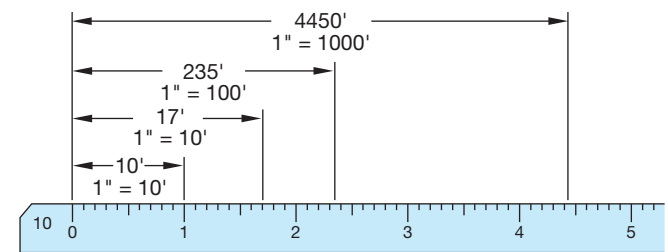
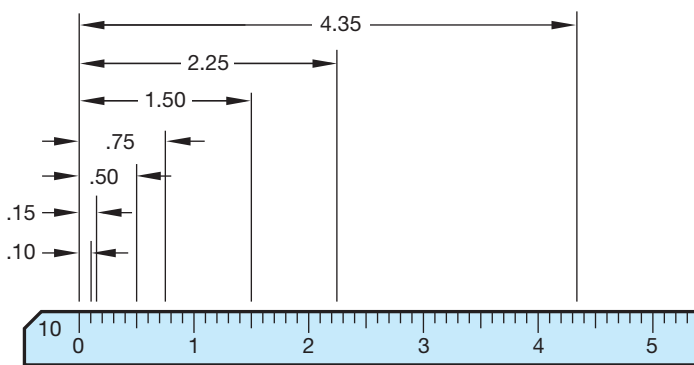
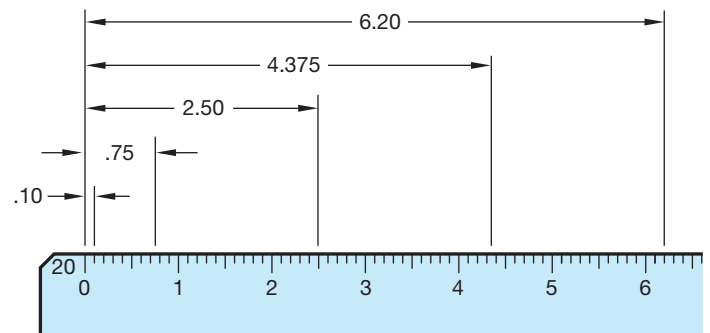


FIGURE 2.19 Metric scale calibrations. © Cengage Learning 2012



for accurate reading. The 10 scale is also used in civil drafting for scales of 1" = 10', 1" = 100', and so on (see Figure 2.21).

The 20 scale is commonly used in mechanical drawing to represent dimensions on a drawing at half-scale (1:2). Figure 2.22 shows examples of half-scale decimal dimensions. The 20 scale



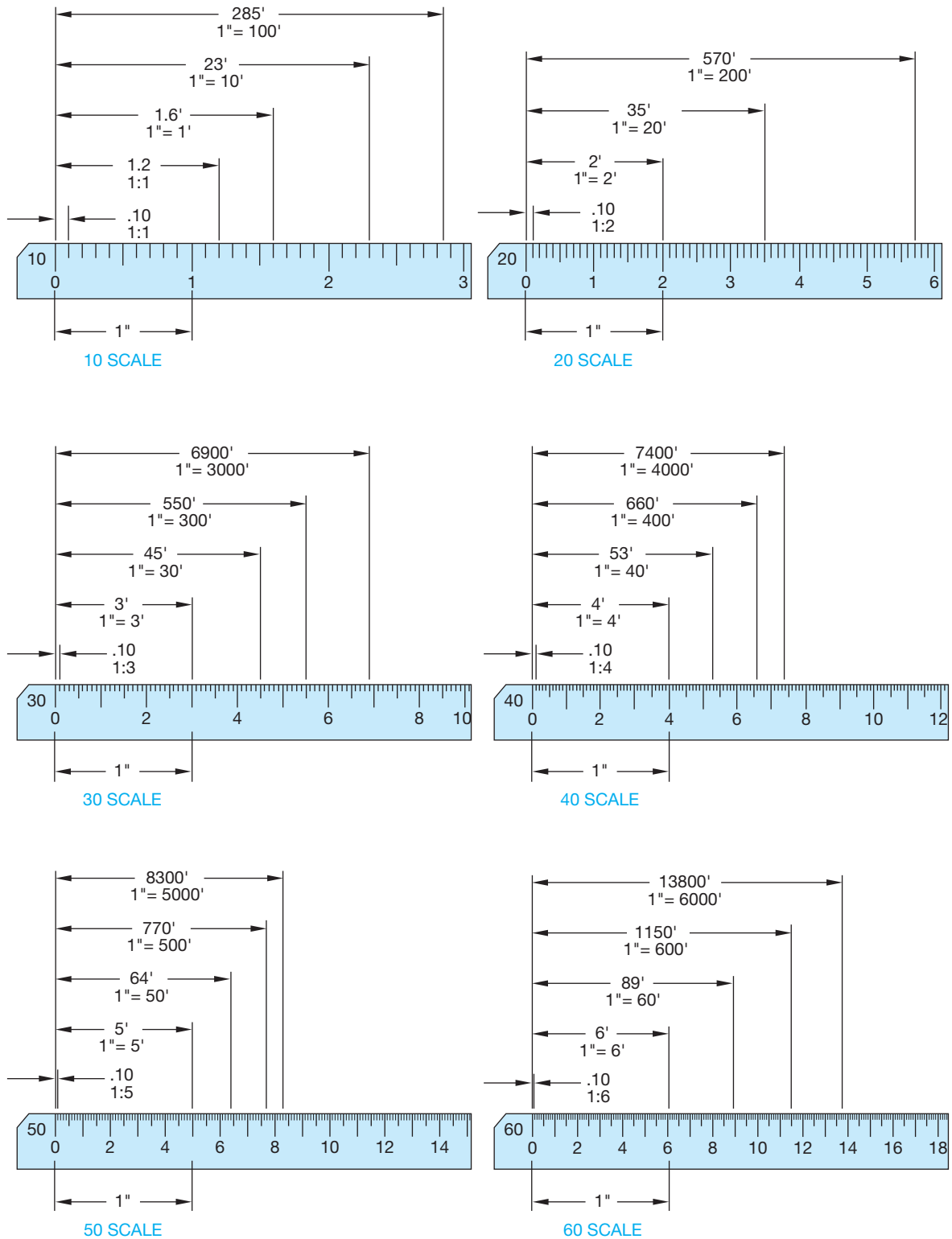


FIGURE 2.23 Civil engineer's scales.

is also used for scales of 1" = 2', 1" = 20', and 1" = 200', as shown in Figure 2.23.

The remaining scales on the civil engineer's scale can be used in a similar fashion—for example, 1" = 5', 1" = 50', and so on. Figure 2.23 shows dimensions on each of the civil engineer's scales. The 50 scale is popular in civil drafting for drawing plats of subdivisions, plot plans, and site plans.

### Architect's Scale

The triangular architect's scale contains 11 different scales. On ten of the scales, each inch represents a specific increment of feet. Each of the feet is subdivided into multiples of 12 parts to represent inches and fractions of an inch. The degree of precision depends on the specific scale. The eleventh scale is the full



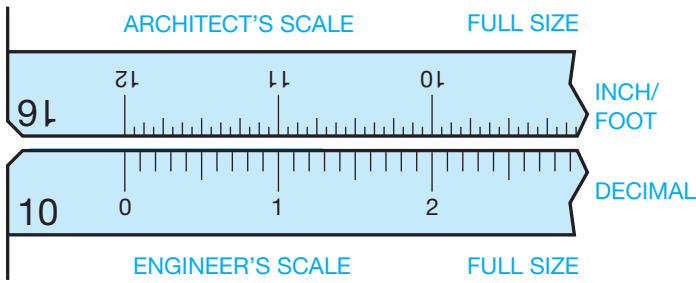


FIGURE 2.24 Comparison of full engineer's scale (10) and architect's scale (16). © Cengage Learning 2012

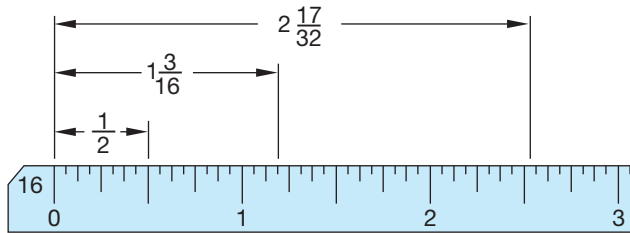


FIGURE 2.25 Full (1:1), or 12" = 1'0", architect's scale.

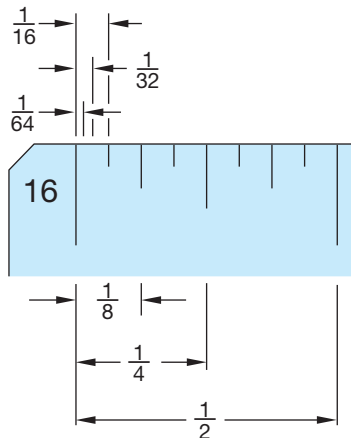


FIGURE 2.26 Enlarged view of architect's (16) scale.

scale with a 16 in the margin. The 16 means that each inch is divided into 16 parts, and each part is equal to 1/16 of an inch. Look at Figure 2.24 for a comparison between the 10 civil engineer's scale and the 16 architect's scale. Figure 2.25 shows an example of the full architect's scale, and Figure 2.26 shows the fraction calibrations that can be estimated in 1/16 of an inch on the full architect's scale.

Look at the architect's scale examples in Figure 2.27. Notice the form in which a drawing expresses the scales. The scale notation can take the form of a word (*full*, *half*, *double*), or a ratio (1:1, 1:2, 2:1) or an equation of the drawing size in inches or fractions of an inch to one foot ( $1" = 1' - 0"$ ,  $3" = 1' - 0"$ ,

$1/4" = 1' - 0"$ ). The architect's scale commonly has scales running in both directions along an edge. Be careful when reading a scale from left to right. Do not confuse the left-to-right calibrations with the scale that reads from right to left. Read full feet values from zero toward the middle of the scale and read inch values at the calibrations provided between zero and the margin of each scale.

## Mechanical Engineer's Scale

The mechanical engineer's scale is commonly used for mechanical drafting when drawings are in fractional or decimal inches. The mechanical engineer's scale typically has full-scale divisions that are divided into 1/16, 10, and 50. The 1/16 divisions are the same as the 16 architect's scale where there are 12 in. and each inch is divided into 1/16 in. increments (or sometimes 1/32 in. divisions). The 10 scale is the same as the 10 civil engineer's scale, where each inch is divided into ten parts, with each division being .10 in. The 50 scale is for scaling dimensions that require additional accuracy, because each inch has 50 divisions. This makes each increment 1/50 in. or .02 in. ( $1 \div 50 = .02$ ). Figure 2.27 shows a comparison between the mechanical engineer's scales. The mechanical engineer's scale also has half-size 1:2 ( $1/2" = 1"$ ), quarter-size 1:4 ( $1/4" = 1"$ ), and eighth-size 1:8 ( $1/8" = 1"$ ) options for reducing the drawing scale (see Figure 2.28). Figure 2.29 on page 53 shows a drawing that is represented at full scale (1:1), half-scale (1:2), and quarter-scale (1:4) for comparison.

## DRAFTING MEDIA

The term **media**, as applied here, refers to the material on which you create drawings, such as paper or polyester film. The two main types of media used for manual drafting are vellum and polyester film, with vellum being the most commonly used. Several factors other than cost also influence the purchase and use of drafting media, including durability, smoothness, erasability, dimensional stability, and transparency.

Durability is a consideration if the original drawing will be extensively used. Originals can tear or wrinkle, and the images can become difficult to see if the drawings are used often. Smoothness relates to how the medium accepts line work and lettering. The material should be easy to draw on so that the image is dark and sharp without a great deal of effort on your part.

Erasability is important because errors need to be corrected, and changes are frequently made. When images are erased, ghosting—the residue that remains when lines are difficult to remove—should be kept to a minimum. Unpleasant ghost images reproduce in a print. Materials that have good erasability are easy to clean. Dimensional stability is the quality of the media to remain unchanged in size because of the effects of atmospheric conditions such as heat, cold, and humidity. Some materials are more dimensionally stable than others.

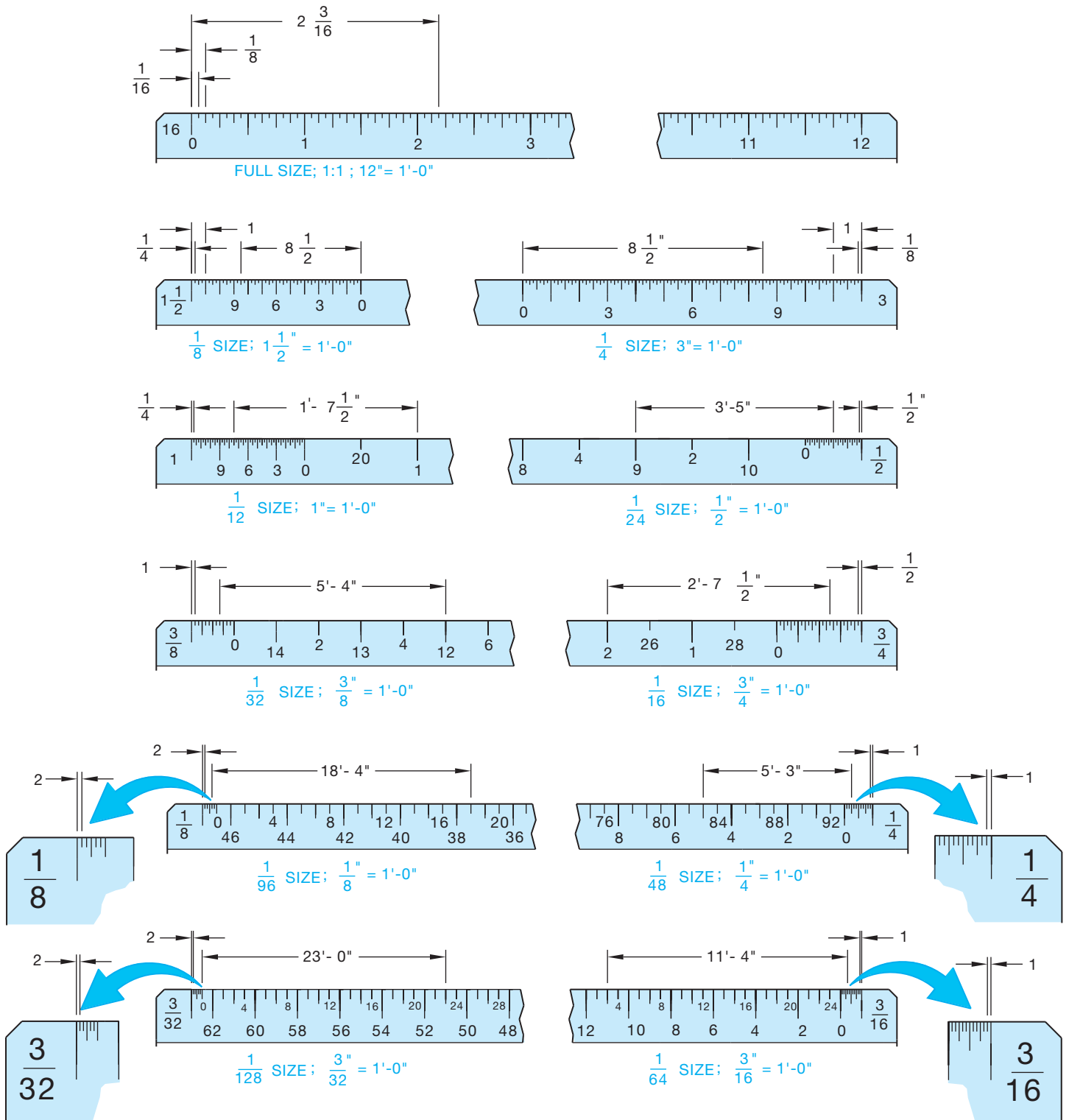


FIGURE 2.27 Architect's scale examples. Values are in inches or feet and inches. © Cengage Learning 2012

Transparency is one of the most important characteristics of drawing media when reproducing the drawing using the diazo print process. The method requires that light pass through the material. This process, explained later in this chapter, has become obsolete because of photocopy reproduction and CADD

printing and plotting. The final goal of a drawing is good reproduction, so the more transparent the material, the better the reproduction, assuming that the image drawn is of professional quality. Transparency is not important when using the photocopy process.

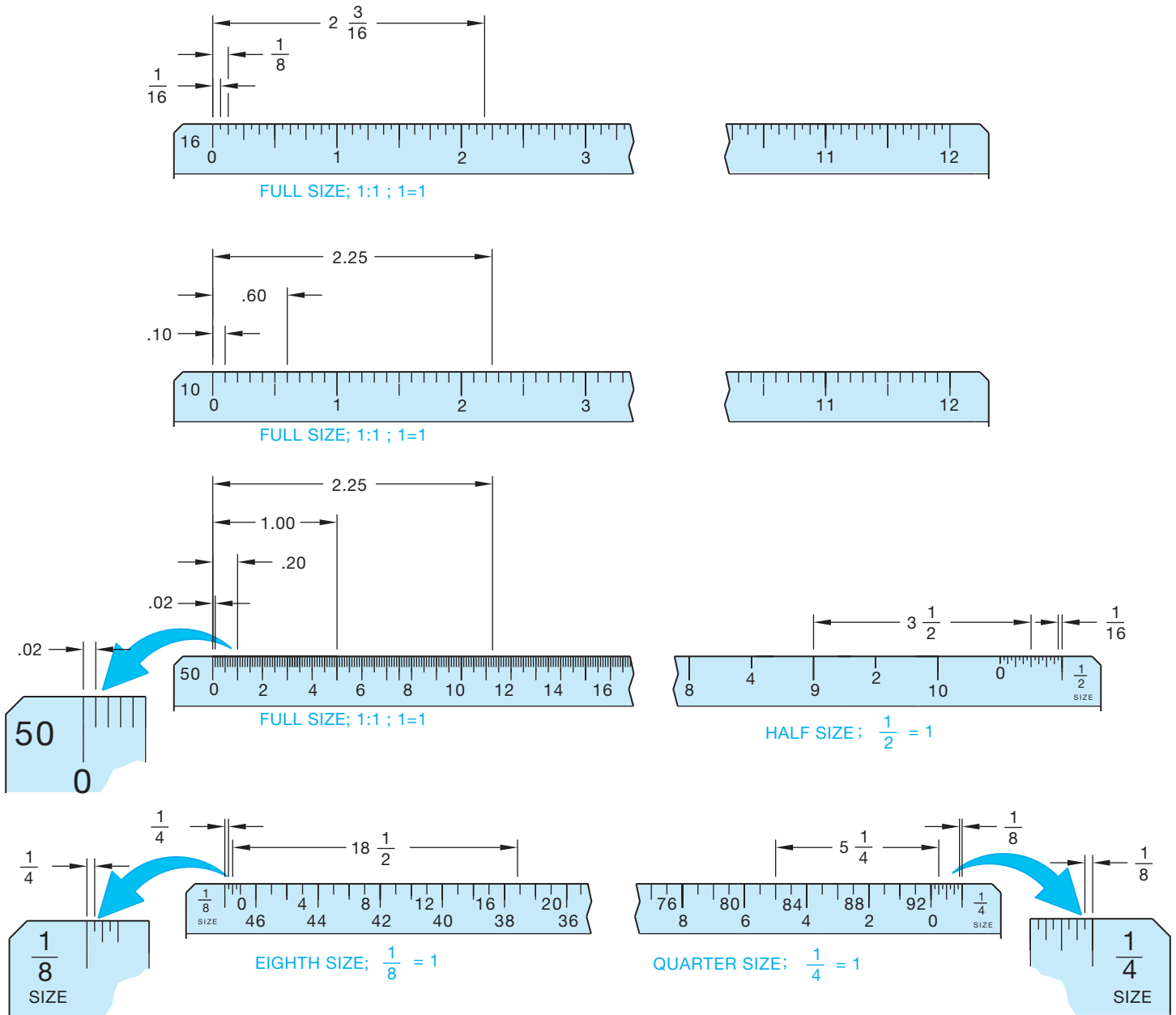


FIGURE 2.28 A comparison of three types of scales. Values are in inches. © Cengage Learning 2012

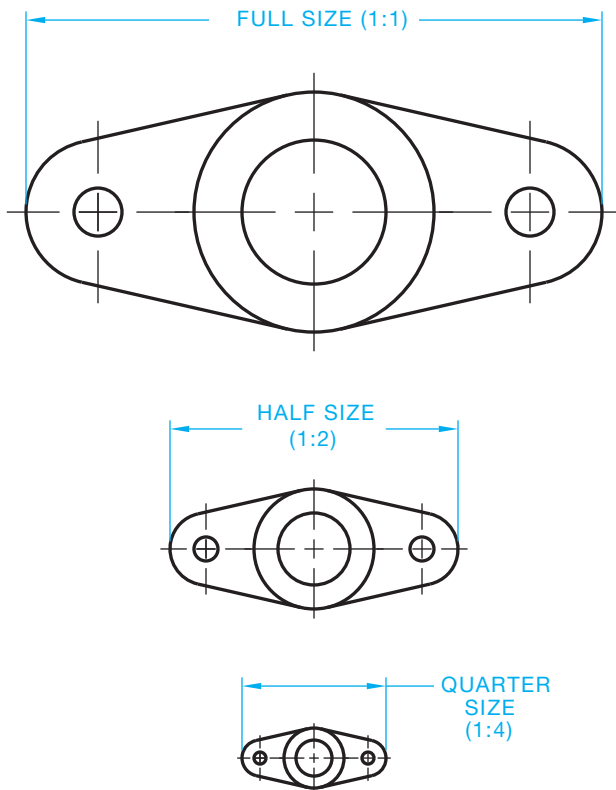
## Vellum

**Vellum** is drafting paper with translucent properties that is specially designed to accept pencil or ink. Graphite on vellum is the most common combination used for manual drafting. Many vendors manufacture quality vellum for drafting purposes. Each claims to have specific qualities that you should consider in the selection. Vellum is the least expensive material that has good smoothness and transparency. Use vellum originals with care. Drawings made on vellum that are extensively used could deteriorate because vellum is not as durable as other materials.

Some brands have better erasability than others. Vellum is generally more affected by humidity and other atmospheric conditions and is less dimensionally stable than other materials.

## Polyester Film

**Polyester film**, also known by its brand name, Mylar®, is a plastic material offering excellent dimensional stability, erasability, transparency, and durability. Drawing on Mylar is best accomplished using ink or special polyester leads. Do not use regular graphite leads because they smear easily.



© Cengage Learning 2012

**FIGURE 2.29** A sample drawing represented at full scale, half-scale, and quarter-scale.



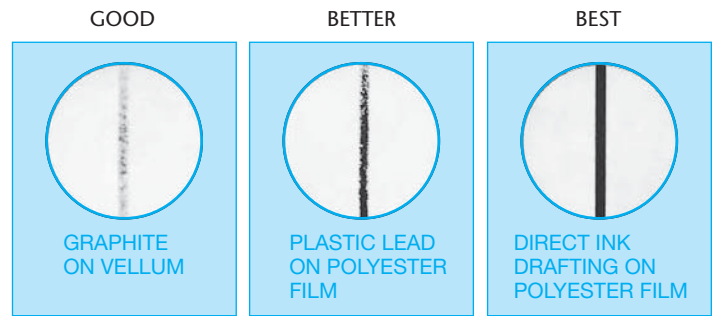
### Using Polyester Film

For more information about polyester film, and using polyester film for manual drafting, go to the Student CD, select **Supplemental Material, Chapter 2**, and then **Using Polyester Film**.

## Reproduction

One thing most designers, engineers, architects, and drafters have in common is that their finished drawings are intended for reproduction. The goal of every professional is to produce drawings of the highest quality that give the best possible prints when reproduced. Many of the factors that influence the selection of media for drafting have been described; however, the most important factor is reproduction. The primary combination that achieves the best reproduction is the blackest and most opaque lines or images on the most transparent base or material.

Vellum and polyester film make good prints if the drawing is well done. If the only concern is the quality of the reproduction, ink on polyester film is the best choice. However, some products have better characteristics than others. Some individuals prefer certain products. It is up to individuals and companies to determine the combinations that work best for their needs and budgets. Look at Figure 2.30 for a magnified view of graphite on vellum, plastic lead on polyester film, and ink on polyester film. As you



**FIGURE 2.30** A magnified comparison of graphite on vellum, plastic lead on polyester film, and ink on polyester film. Courtesy Koh-I-Noor, Inc.

can see from the figure, the best reproduction is achieved with a crisp, opaque image on transparent material. If your original drawing is not good quality, it does not get better when reproduced.



### Taping Down a Drawing

For information about properly taping down your drawing on a drafting board, go to the Student CD, select **Supplemental Material, Chapter 2**, and then **Taping Down a Drawing**.

## SHEET SIZE AND FORMAT

### STANDARDS

**ASME** The ASME documents ASME Y14.1, *Decimal Inch Drawing Sheet Size and Format*, and ASME Y14.1M, *Metric Drawing Sheet Size and Format*, specify standard sheet sizes and format.

Most professional drawings follow specific standards for sheet size and format. The ASME Y14.1 and ASME Y14.1M standards specify the exact sheet size and format for engineering drawings created for the manufacturing industry. Other disciplines can follow ASME standards. However, architectural, civil, and structural drawings used in the construction industry generally have a different sheet format and may use unique sheet sizes, such as architectural sheet sizes. You will learn about sheet sizes and formats for other disciplines in chapters where specific disciplines are covered. Follow sheet size and format standards to improve readability, handling, filing, and reproduction; this will also help ensure that all necessary information appears on the sheet.

When selecting a sheet size, consider the size of objects drawn; the drawing scale; the amount of additional content on the sheet, such as a border, title block, and notes; and drafting standards. In general, choose a sheet size that is large enough to show all elements of the drawing using an appropriate scale and without crowding. For example, the dimensioned views of a machine part that occupies a total area of 15 in. × 6 in. (381 mm × 153 mm), can typically fit on a 17 in. × 11 in. (B size) or 420 mm × 297 mm (A3 size) sheet. A larger sheet

will likely display too much blank area and is an unnecessary use of material. A smaller sheet will not support the dimensioned views and the remaining elements of the drawing, such as the title block. The 11 in. × 8.5 in. (A size) and 297 mm × 210 mm (A4 size) sheets are generally reserved for drawings of small objects with little detail. Often specific project requirements control sheet size. For example, a company may use a specific sheet size for all drawings given to workers in a machine shop, or a manufacture or government agency might require drawings submitted on a certain sheet size.

A sheet usually displays elements such as a border and title block. The ASME Y14.1 and ASME Y14.1M documents dictate the exact size, location, appearance, and content of items on a sheet. When using CADD, save sheet elements in a drawing template file for repeated use. Manual drafting sheets are available with preprinted borders and title blocks to reduce drafting time and cost. A standard sheet format helps to ensure that all necessary information appears in the title block and on the surrounding sheet next to the border so the drawing is easy to read and file. The following is a list of standard and optional items found on common sheet sizes, as described in detail in this chapter, according to ASME standards:

- Border.
- Zoning.
- Title block.
- Angle of projection block.
- Dimensioning and tolerancing block.
- Revision history block.
- Revision status of sheets block.
- Revision status notation.
- Margin drawing number block.
- Application block.
- Microfilm alignment arrows.

Companies often modify or add content to a sheet not directly specified by ASME standards. Common examples include blocks for additional CADD file information, copyright and propriety statements, and engineering stamps.

## Sheet Size

ASME Y14.1, *Decimal Inch Drawing Sheet Size and Format*, specifies the following common inch drawing sheet sizes.

Size Designation	Size in Inches	
	Vertical	Horizontal
A	8½	11 (horizontal format)
	11	8½ (vertical format)
B	11	17
C	17	22
D	22	34
E	34	44
F	28	40

Figure 2.31 shows standard inch sheet sizes and format. The additional sheet sizes G, H, J, and K apply to specific roll sizes. Roll sizes offer variable horizontal measurements. For example, a G-size sheet is 11 in. vertical and between 22.5 in. and 90 in. horizontal, depending on the requirement. Roll sizes are uncommon in the drafting industry and typically used for very long full-scale or enlarged scale machine components. Roll sizes require additional margin, zone, and microfilm format considerations as specified by ASME standards.

ASME Y14.1M, *Metric Drawing Sheet Size and Format*, specifies the following common metric drawing sheet sizes. The M in the title of the document Y14.1M means all specifications are given in metric.

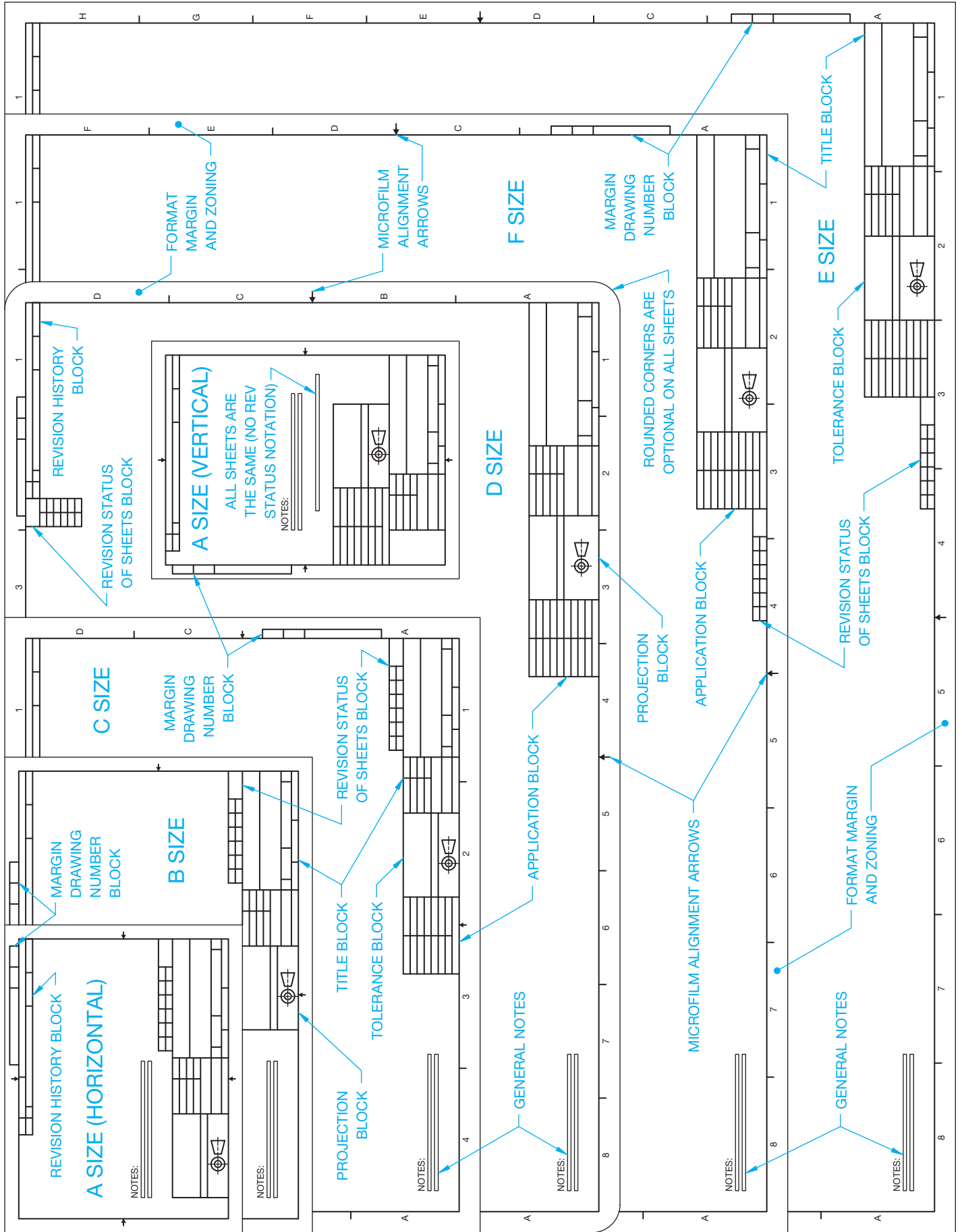
Size Designation	Size in Millimeters	
	Vertical	Horizontal
A0	841	1189
A1	594	841
A2	420	594
A3	297	420
A4	210	297

Figure 2.32 shows standard metric sheet sizes. The additional sheet sizes A1.0, A2.1, A2.0, A3.2, A3.1, and A3.0 apply to specific elongated sizes. Elongated sizes are horizontally longer than standard sheets. For example, an A2.0-size sheet is 420 mm vertically, the same vertical measurement as an A2, but 1189 mm horizontally. Elongated sizes are uncommon in the drafting industry and typically used for very long full-scale or enlarged scale machine components. Elongated sizes require additional margin, zone, and microfilm format considerations as specified by ASME standards.

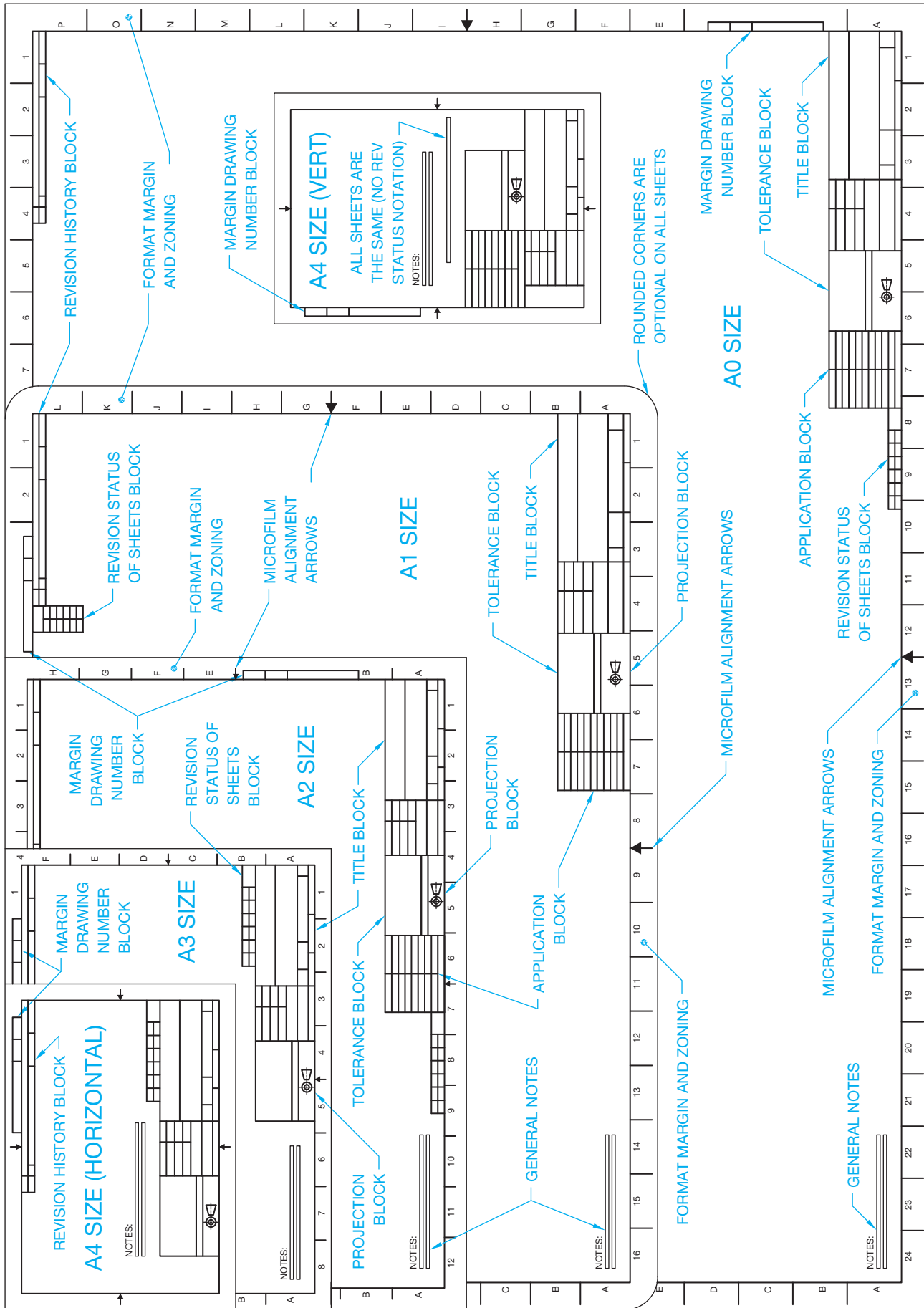
Certain CADD plotters and printers may require you to use a larger-than-standard sheet size because of the plotter or printer margin requirements. You must then trim plotted sheets to adhere to ASME standards. Some plotters offer the ability to use a roll of media to plot specific sheet sizes. For example, use a 34 in. roll to plot D-size and E-size sheets. Do not confuse G, H, J, K, and elongated roll sizes with standard size sheets cut from a roll of media.

## Line and Lettering Format

The ASME Y14.2M, *Line Conventions and Lettering*, standard specifies exact line and lettering format for all items on a drawing, as fully described in Chapter 7 of this textbook. Use thick lines of 0.6 mm (.02 in.) for borders, the outline of principal blocks, and main divisions of blocks. Use thin lines of 0.3 mm (.01 in.) for dividing parts lists and revision history blocks, and for minor subdivisions of the title block and supplementary blocks. When using CADD, you do not have to follow the exact ASME line width standards for sheet items, such as borders and blocks. For example, the precision of CADD and plotters allows you to use thick lines for minor subdivisions of the title block, if desired.



**FIGURE 2.31** Standard inch drawing sheet sizes and format. Notice that an F-size sheet is smaller than an E-size sheet. © Cengage Learning 2012



**FIGURE 2.32** Standard metric drawing sheet sizes and format. © Cengage Learning 2012

The lettering style on engineering drawings, including sheet elements, should be vertical, uppercase Gothic as specified by the instructor, or company standards. CADD uses vertical uppercase letters of an Arial, Roman, or similar font, unless otherwise specified. You will learn more about CADD text later in this textbook. The following chart shows recommended minimum letter heights used for sheet elements. All lettering should be from .10 in. to .24 in. (2.5 mm to 6 mm) high as indicated.

Sheet Elements	Minimum Letter Heights INCH	Drawing Sizes INCH	Letter Heights METRIC (mm)	Drawing Sizes METRIC
Drawing title, sheet size, CAGE code, drawing number, revision letter in the title block	.24	D, E, F, H, J, K	6	A0, A1
Drawing title, sheet size, CAGE code, drawing number, revision letter in the title block	.12	A, B, C, G	3	A2, A3, A4
Zone letters and numbers in borders	.24	All sizes	6	All sizes
Drawing block headings	.10	All sizes	2.5	All sizes
All other characters	.12	All sizes	3	All sizes

### Border

The border is the format margin of a sheet, usually between the edges of the sheet to borderlines. The borderlines form a rectangle to establish the border. Distinct from the blank margins common on documents, a drawing border for standard size sheets can include zoning, a margin drawing number block, and microfilm alignment arrows. The ASME minimum distance from the edges of the sheet to borderlines, which forms the format margins, is .5 in. for all inch drawing sheet sizes; 20 mm for A0- and A1-size sheets; and 10 mm for A2-, A3-, and A4-size sheets.

The ASME minimum format margins do not include added protective margins for roll and elongated sheet sizes, binding margins for binding a set of sheets in a book form, or adjustments for CADD plotter or printer margin requirements. Larger format margins are necessary for these applications, especially when plotting a CADD drawing to a device with a reduced printable area and when using zoning. Increase margins as needed to between .75 in. and 1 in. for inch drawings and between 30 mm and 40 mm for metric drawings. Horizontal and vertical margins can vary if desired. For example, add an additional

.75 in. (20 mm) to the left margin to create room for binding or choose different horizontal and vertical margins according to a specific plot device.

### Zoning

Zoning is a system of numbers along the top and bottom margins and letters along the left and right margins. ASME standards recommend zoning for all sheets but as an option for A, B, and A4 sizes. Zoning allows a drawing to read like a road map. For example, you can refer to the location of a specific item as D4, which means that the item can be found at or near the intersection of D across and 4 up or down. Zone spacing for inch sheets should be equal with no zone less than 1 in. long or greater than 5.50 in. long (see Figure 2.31). Metric sheet zones should be equally spaced except that the upper and left zones can be an odd size to contain the remaining sheet size (see Figure 2.32).

### Title Block

A title block provides a variety of information about a drawing, such as the title of the drawing, sheet size, and predominant scale, as described later in this chapter. ASME standards recommend placing the title block in the lower right corner of sheet borderlines as shown in Figure 2.31 and Figure 2.32. ASME standards provide specific dimensions and content requirements for title blocks. However, some companies prefer to use a slightly different title block design, as shown by the example in Figure 2.33. Other sheet blocks often group with the title block. The most common examples are dimensioning and tolerancing and the angle of projection blocks (see Figure 2.34).

The ASME-recommended title block format has features that can vary, depending on the drawing requirements, company preference, and applications. Figure 2.35 shows the general ASME-recommended format for title blocks. The numbers shown on Figure 2.35 refer to the following blocks found within the title block. You will learn more about each item when applicable throughout this textbook.

1. **Company or Design Activity:** Normally displays the name, address, and contact information of the company, or it can provide original design activity content.


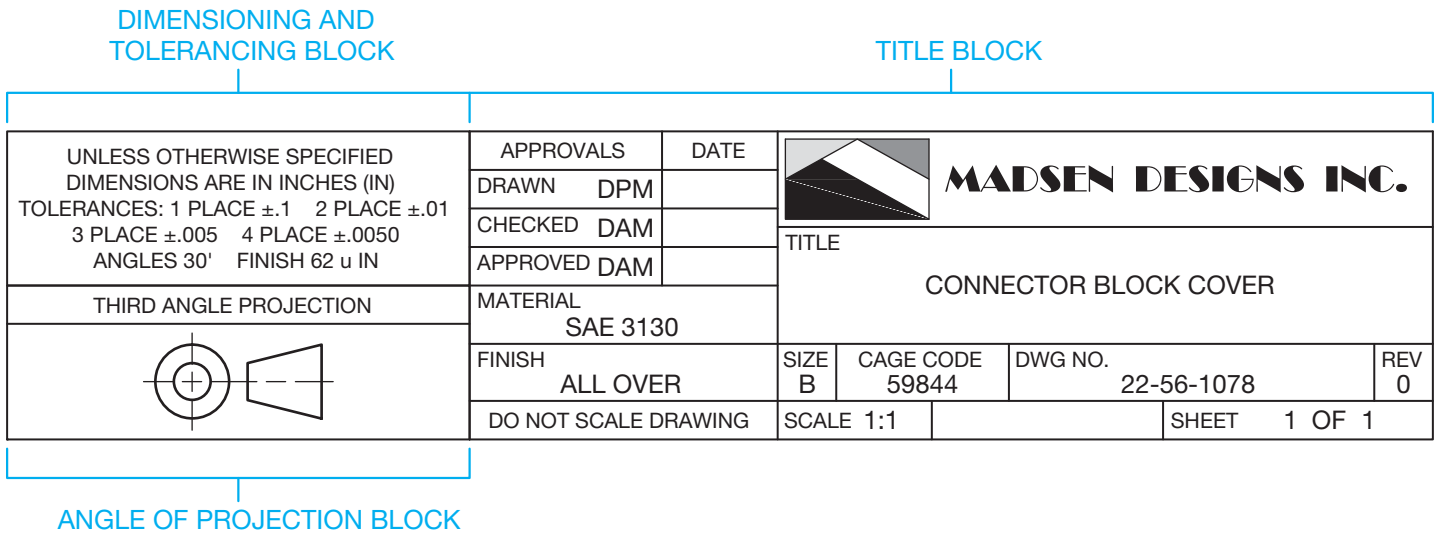
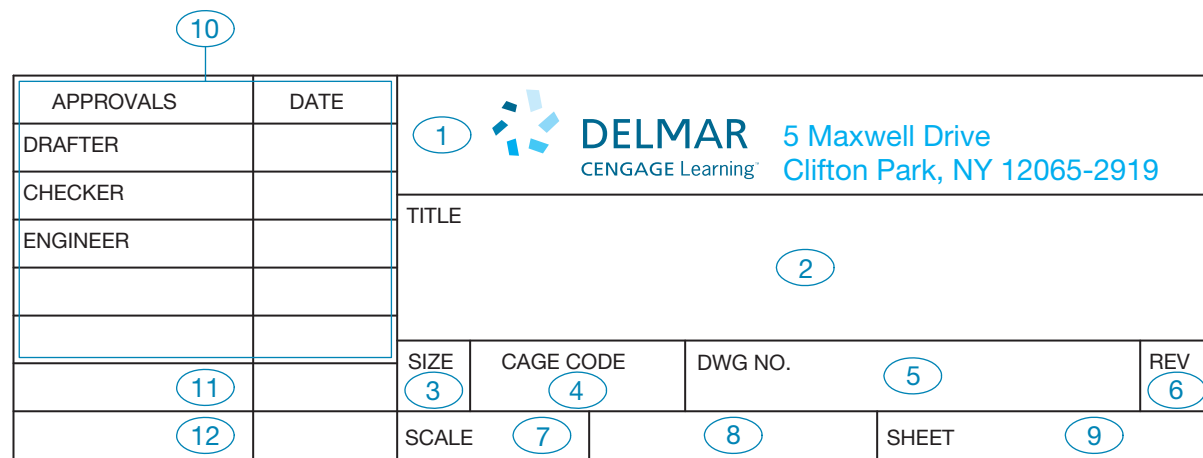
		HUNTER FAN COMPANY 2500 FRISCO AVE., MEMPHIS, TENN. 38114	
THIS DOCUMENT AND THE INFORMATION IT DISCLOSES IS THE EXCLUSIVE PROPERTY OF HUNTER FAN COMPANY. ANY REPRODUCTION OR USE OF THIS DRAWING, IN PART OR IN WHOLE, WITHOUT THE EXPRESS CONSENT OF THE PROPRIETOR ARE PROHIBITED.			
TOLERANCES: (UNLESS OTHERWISE SPECIFIED) DECIMAL: .XX = ± _____ .XXX = ± _____ FRACTIONAL: ± _____ ANGULAR: ± _____	DATE: 5/21/96	DRAWN BY: DICK PEARCE	DEPARTMENTAL APPROVALS
	SCALE: FULL	CHK'D BY:	R&D: Q.A.:
	FIRST USE: AIR FORCE FAN	ENG:	MFG:
	REFERENCE:	MRKTG:	I.D.:
PART NAME BLADE RING		PART NO. 92678	

FIGURE 2.33 Sample title block slightly different than specified by ASME standards. Courtesy Hunter Fan Company, Memphis, TN.





**FIGURE 2.34** Other sheet data blocks, such as the dimensioning and tolerancing, and angle of projection blocks often group with the title block. Courtesy Madsen Designs Inc.



**FIGURE 2.35** Title block elements according to ASME standards.

- Title:** Displays the title of the drawing, which is typically the product assembly name or the specific part or sub-assembly name.
- Sheet Size:** Identifies the sheet size designation such as A, B, A4, or A3.
- CAGE Code:** A five-number code assigned by the United States Defense Logistic Service Center (DLSC) to all Department of Defense contractors. CAGE stands for Commercial And Government Entity. The **CAGE code** must appear on all drawings of products designed for the U.S. government. CAGE was previously known as FSCM, which stands for Federal Supply Code for Manufacturers.
- Drawing Number:** Some companies specify the part or related number as the drawing number. Most companies have their own drawing- or part-numbering systems. Although numbering systems differ, they often provide keys to categories such as the nature of the drawing (for example, casting, machining, or assembly), materials used, related department within the company, the project, or numerical classification of the product.
- Revision:** Specifies the current revision of the part or drawing. A new or original drawing is—(dash) or 0 (zero). The first time a drawing is revised, the— or 0 changes to an A; for the second drawing change, a B is placed here; and so on. The letters I, O, Q, S, X, and Z are not used because they might be confused with numbers. When all of the available letters A through Y have been used, double letters are used such as AA and AB, BA and BB. Some companies use revision numbers rather than letters. Some companies do not use this compartment when the revision history block is on the same sheet.
- Scale:** Specifies the principal drawing scale, such as FULL or 1:1, HALF or 1:2, DBL or 2:1, and QTR or 1:4. Enter NONE when there is no scale.
- Weight:** Indicates the actual or estimated weight of the part or assembly. Some companies may use this block for other purposes, such as to identify material.

9. **Sheet:** Identifies the sheet relative to a group of sheets or set of sheets. When multiple sheets are required to display a single drawing, the sheet block organizes the multiple-sheet drawing. For example, if there are two sheets needed to show a drawing, the first sheet is 1/1 or 1 OF 1, and the second sheet is 2/2 or 2 OF 2. The first sheet has the complete title block and other sheet blocks, such as the angle of projection block and dimensioning and tolerance block. Additional sheets can have the same set of blocks, or they can have a **continuation sheet title block**. The continuation sheet title block uses a minimum of the drawing number, scale, sheet size, CAGE code, and sheet number. When the sheet is a member of a set of different drawings, the sheet block organizes the set as described in Chapter 15, *Working Drawings*.
10. **Approvals 1:** The entire area above items 11 and 12 in Figure 2.35 typically allows for approval names or signatures, as well as dates by people directly involved with preparing and approving the drawing, such as the drafter, checker, and engineer. For example, if you are the drafter, identify yourself in the DRAFTER block by using all your initials such as DAM, DPM, or JLT. Fill in the date block in order by day, month, and year such as 18 NOV 10 or numerically with month, day, and year such as 11/18/10. Confirm the preferred name and date format with your school or company standards. When a drawing is complete, it usually goes to a **checker** for inspection. A checker is a person who is responsible for checking drawings for content and accuracy. Each company or project follows specific approval guidelines. Figure 2.35 shows an example of using APPROVALS and DATES columns to divide approval blocks. Drawings that do not require extensive approvals often use a portion of this area for other information such as material and finish specifications.
11. **Approval 2:** Allows for approval by an individual, design activity, or organization not directly related with preparing or approving the drawing, such as a subcontractor hired to manufacture the product. This block may be required when producing drawings for the United States government. If no outside approvals are necessary, this block is used for inside approvals, other information, or is left blank.
12. **Approval 3:** Allows for approval by an individual, design activity, or organization not specified in the other approval blocks. This block can be required when producing drawings for the United States government. If no outside

approvals are necessary, this block is used for inside approvals, other information, or is left blank.

### Angle of Projection Block

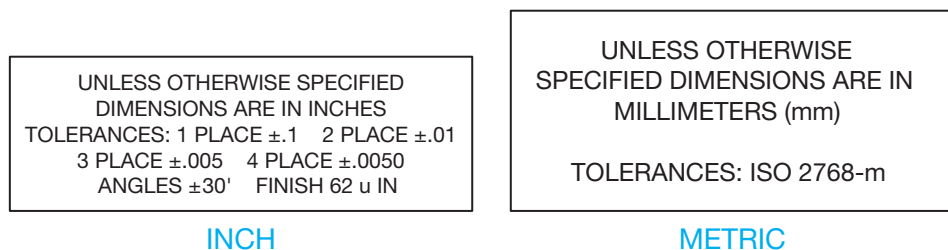
The **angle of projection block**, shown in Figure 2.34, specifies how to interpret a drawing according to the method of view projection. The THIRD ANGLE PROJECTION notation and related symbol means that the views on the drawing are created using the third-angle projection system. The other option is FIRST ANGLE PROJECTION. Most drawings in this textbook use third-angle projection unless otherwise specified. Chapter 9 offers a complete description of view projection.

### Dimensioning and Tolerancing Block

The **dimensioning and tolerancing block** is used to specify the general dimensioning and tolerancing specifications found on the drawing. Figure 2.36 shows inch and metric dimensioning and tolerancing blocks. Typically, the upper portion of the dimensioning and tolerancing block provides a note indicating that all dimensions are in millimeters (mm) or inches (IN), unless otherwise specified, such as UNLESS OTHERWISE SPECIFIED DIMENSIONS ARE IN INCHES (IN). The compartment continues with information about **unspecified tolerances**. Chapter 10, *Dimensioning and Tolerancing*, explains tolerances in detail, although it is important to know that a tolerance is a given amount of acceptable variation in a size or location dimension. Every dimension has a tolerance. **Unspecified tolerances** refer to any dimension on the drawing that does not have a tolerance specified. This is when the dimensional tolerance required is the same as the general tolerance shown in the dimensioning and tolerancing block.

Tolerancing applications depend on company practice and manufacturing applications. Unspecified tolerances for inch dimensions typically establish one, two, three, and four place decimals in a manner similar to the inch unit example shown in Figure 2.36. Angular tolerances for unspecified angular dimensions are typically  $\pm 30'$ . The unspecified surface finish can also be given for surfaces that are identified for finishing without a specific callout. Chapters 4, *Manufacturing Materials and Processes*, and 10, *Dimensioning and Tolerancing*, explain surface finish.

The International Organization for Standardization (ISO) standard ISO 2768, *General Tolerances*, generally controls



**FIGURE 2.36** An example of an inch and a metric dimensioning and tolerancing block.

unspecified tolerances for metric dimensions. ISO 2768 tolerancing is based on the size of features. Small sizes have closer tolerances, and larger sizes have larger tolerances. The four classes of size tolerances are fine (f), medium (m), coarse (c), and very coarse (v). Each class is represented by its abbreviation in parentheses. A company can select the class that best meets its dimensioning requirements. For example, a company that manufactures precision parts and equipment might select the medium class for general metric tolerances. A general note that states the ISO 2768 class for general tolerances, such as ISO 2768-m, is placed on the drawing (see Figure 2.36). Chapter 10 describes metric dimensioning and tolerancing in detail.

### Revision History Block

The **revision history block**, also called the **revision block**, is used to record changes to the drawing and is located in the upper right corner of sheet borderlines as shown in Figures 2.31 and 2.32, though some companies use other placements. You must reserve room in the right portion of the sheet, below the revision block, to add drawing revision information when necessary. When the revision content exceeds the space available, add a supplemental revision history block to the left of the original revision block. Drafting revisions occur in chronological order by adding horizontal columns and extending the vertical column lines.

Figure 2.37 shows the general ASME-recommended format for revision history blocks. The circled numbers in Figure 2.37 refer to the following blocks found within the revision history block:

1. **Zone:** Only used if the drawing includes zoning and specifies the location of the revision. For example, enter D4 in

the ZONE column if the location of the change is at or near the intersection of D up or down and 4 across.

2. **Revision:** Enter the revision letter or number, such as A, B, C, or D. Succeeding letters are to be used for each engineering change. You must change the value in REV block of the title block, previously described, to agree with the last REV letter in the revision block. **Revisions** happen when parts are redesigned or revised for any reason and the drawing changes. All drawing changes are commonly documented and filed for future reference. When this happens, the documentation should be referenced on the drawing so users can identify that a change has been made. Before any revision can be made, the drawing must be released for manufacturing. Chapter 15, *Working Drawings*, describes the drawing revision process in detail.
3. **Description:** Gives a short description of the change.
4. **Date:** Fill in the day, month, and year on which the engineering change is ready for release to production, such as 6 APR11, or use month, day, and year numbers such as 4/6/11. Confirm the proper format with your school or company standards.
5. **Approval:** Add the initials of the person approving the change and the optional date.

### Revision Status of Sheets Block

A **revision status of sheets block**, shown in Figure 2.38, appears on the first sheet of multiple-sheet drawings and records the revision status of each drawing. This block is not required

REVISION HISTORY				
ZONE	REV	DESCRIPTION	DATE	APPROVED
①	②	③	④	⑤

FIGURE 2.37 Revision block elements according to ASME standards.

HORIZONTAL					
0	0	C	A	C	REV
5	4	3	2	1	SH

VERTICAL	
REV	SH
C	1
A	2
C	3
0	4
0	5

FIGURE 2.38 Examples of vertical and horizontal revision status of sheets blocks.

on single-sheet drawings. The revision status of sheets block can be horizontal or vertical, and can be located by the title block or in the area of the revision history block as shown in Figure 2.31 and Figure 2.32.

### Revision Status Notation

The revision status notation, ALL SHEETS ARE THE SAME REVISION STATUS, is optional and can be used next to the title block when the revision status of all sheets is the same. Figure 2.31 shows the location of the revision status notation on the vertical A-size sheet, and Figure 2.32 shows the location on the vertical A4-size sheet.

### Additional Sheet Blocks and Symbols

A sheet can include several additional blocks and symbols, depending on project requirements and company practice. Figure 2.39 shows examples of a margin drawing number block, application block, and microfilm alignment arrows. Refer to Figure 2.31 and Figure 2.32 for the position of sheet elements according to sheet size.

#### Margin Drawing Number Block

A margin drawing number block, shown in Figure 2.39a, is optional and is used to identify the drawing number and sheet number, as well as optional revision, when reading the margin information on the drawing. The margin drawing number can be horizontal or vertical and appear in the locations shown in Figures 2.31 and 2.32.

### Application Block

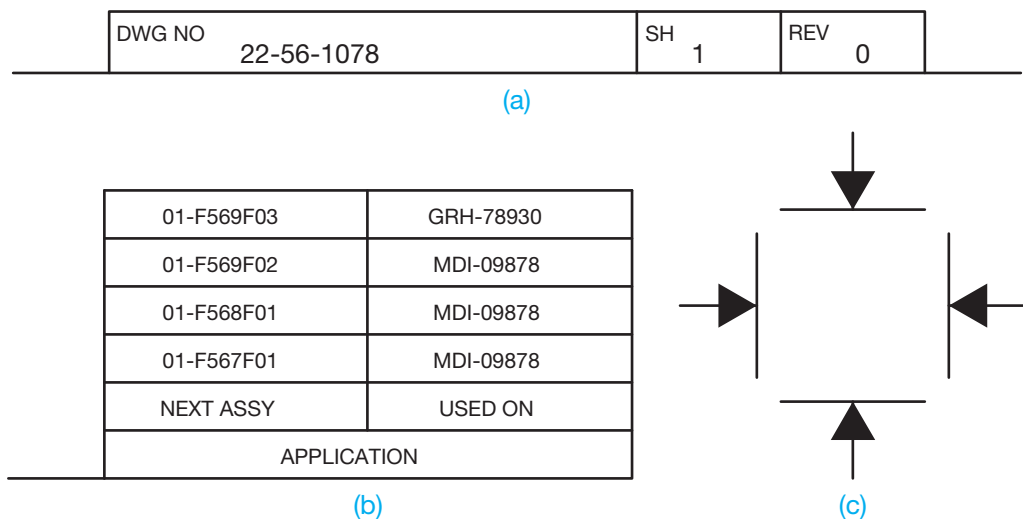
An **application block**, shown in Figure 2.39b, is optional and includes information such as next assembly and where used for drawings of a detail part or assembly of a component of a larger assembly. The NEXT ASSEMBLY (ASSY), NEXT HIGHER ASSEMBLY (NHA), or similar column refers to the next assembly where the part represented in the drawing is used. The USED ON, USED WITH, MODEL NO, or similar column typically refers to the main assembly, system, or product that uses the next assembly. The application block usually appears next to the title block when used.

### Microfilm Alignment Arrows

Microfilm alignment, or centering, arrows, shown in Figure 2.39c, are placed in the margin of drawings for use in **microfilm** alignment. Microfilm is a film on which drawings or other printed materials are photographed at greatly reduced size for ease of storage. You will learn more about microfilm later in this chapter.

**Dimensions of Sheet Items**

For more of the ASME-recommended dimensions of title blocks, angle of projection blocks, dimensioning and tolerancing blocks, revision history blocks, margin drawing number blocks, revision status of sheet blocks, application blocks, and microfilm alignment arrows and identification blocks, go to the Student CD, select **Supplemental Material, Chapter 2**, and then **Dimensions of Sheet Items**.



**FIGURE 2.39** Additional sheet blocks and symbols. (a) Margin drawing number block. (b) Application block. (c) Microfilm alignment, or centering, arrows.



## Drafting Templates

To access CADD template files with predefined drafting settings, go to the Student CD, select **Drafting Templates** and then the appropriate template file. Use the templates to create new designs, as a resource for drawing and model content, or for inspiration when developing your own templates. The ASME-Inch and ASME-Metric drafting templates follow ASME, ISO, and related mechanical drafting standards. Drawing templates include standard sheet sizes and formats, in addition to a variety of appropriate drawing settings and content. You can also use a utility such as the AutoCAD DesignCenter to add content from the drawing templates to your own drawings and templates. Consult with your instructor to determine which template drawing and drawing content to use.

## DIAZO REPRODUCTION

**Diazo prints** are also known as *ozalid dry prints* and *blue-line prints*. The diazo reproduction process has been mostly replaced by photocopy reproduction and the use of CADD files for printing and plotting. Diazo printing uses a process that involves an ultraviolet light passing through a translucent original drawing to expose a chemically coated paper or print material underneath. The light does not go through the dense, black lines on the original drawing, so the chemical coating on the paper beneath the lines remains. The print material is then exposed to ammonia vapor, which activates the remaining chemical coating to produce blue, black, or brown lines on a white or colorless background. The print that results is a diazo, or blue-line print, not a blueprint. The term **blueprint** is a generic term used to refer to diazo prints even though they are not true blueprints. Originally, the blueprint process created a print with white lines on a dark blue background.



## Making a Diazo Print

For more information about making diazo prints and safety precautions required when using the diazo process, go to the Student CD, select **Supplemental Material, Chapter 2**, and then **Making a Diazo Print**.

## PHOTOCOPY REPRODUCTION

**Photocopy printers** are also known as **engineering copiers** when used in an engineering or architectural environment. A photocopy printer is a machine for photographically reproducing

material, especially by xerography. **Xerography** is a dry photographic or photocopying process in which a negative image formed by a resinous powder on an electrically charged plate is electrically transferred to and fixed as a positive image on a paper or other copying surface. Prints can be made on bond paper, vellum, polyester film, colored paper, or other translucent materials. The reproduction capabilities also include instant print sizes ranging from 45 percent to 141 percent of the original size.

Larger or smaller sizes are possible by enlarging or reducing in two or more steps. Almost any large original can be converted into a smaller-sized reproducible print, and then the secondary original can be used to generate additional photocopy prints for distribution, inclusion in manuals, or for more convenient handling. In addition, a random collection of mixed-scale drawings can be enlarged or reduced and converted to one standard scale and format. Reproduction clarity is so good that halftone illustrations (photographs) and solid or fine line work have excellent resolution and density.

The photocopy process and CADD printing and plotting have mostly replaced the diazo process. Photocopying has many advantages over diazo printing, including quality reproduction in many sizes, use of most common materials, and no hazardous ammonia. A CADD system allows you to produce a quality **hard copy** print quickly. A hard copy is a physical drawing produced by a printer or plotter. The hard copy can be printed on vellum for further reproduction using the diazo or photocopy process. Chapters 3 and 4 of this textbook provide detailed information on CADD printing and plotting.

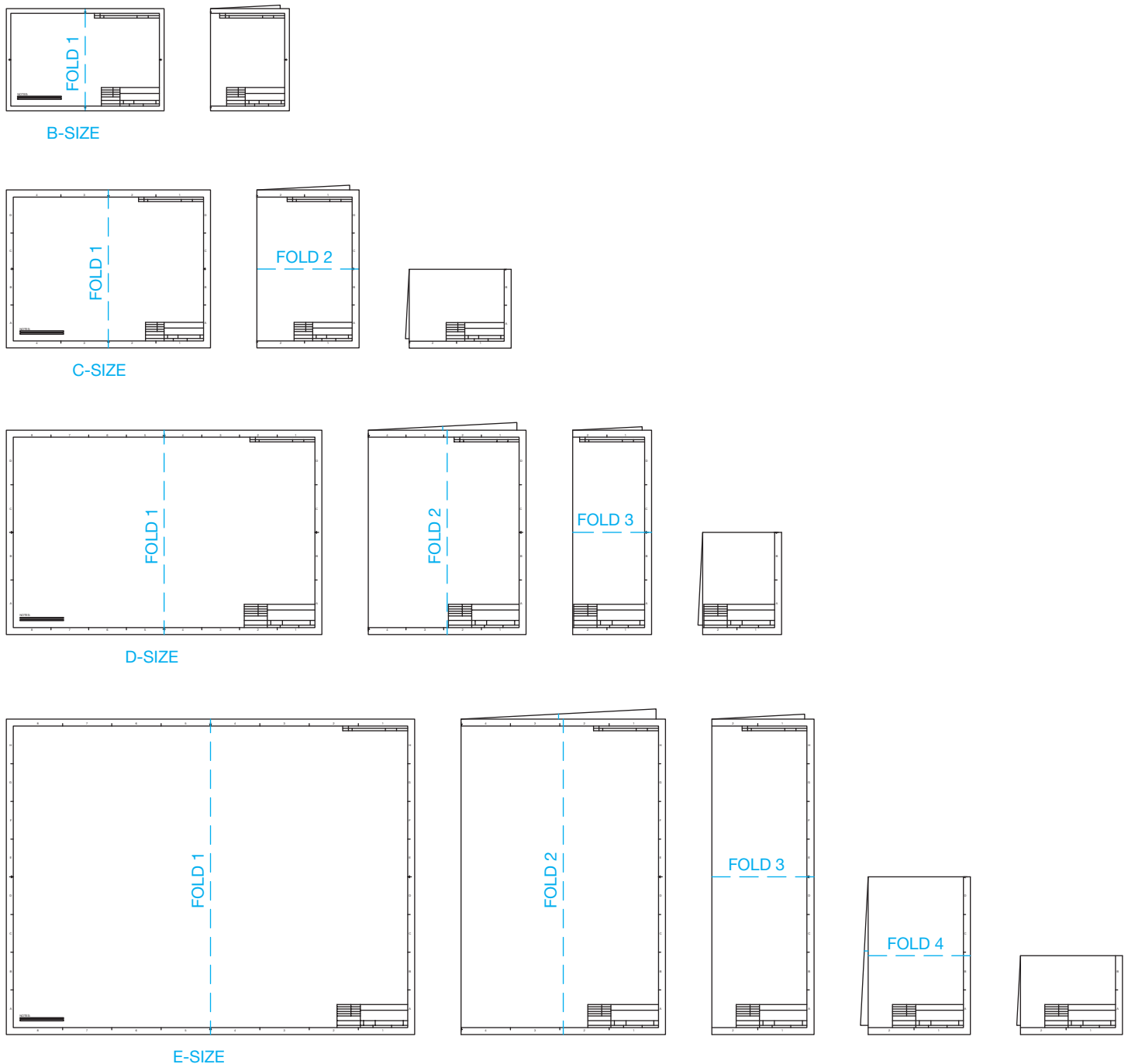
## PROPERLY FOLDING PRINTS

Prints come in a variety of sizes ranging from small,  $8\frac{1}{2} \times 11$  in., to  $34 \times 44$  in. or larger. It is easy to file the  $8\frac{1}{2} \times 11$  in. size prints because standard file cabinets are designed to hold this size. There are file cabinets available called flat files that can be used to store full-size unfolded prints. However, many companies use standard file cabinets. Larger prints must be properly folded before they can be filed in a standard file cabinet. It is also important to fold a print properly if it is to be mailed.

Folding large prints is much like folding a road map. Folding is done in a pattern of bends that results in the title block and sheet identification ending up on the front. This is desirable for easy identification in the file cabinet. The proper method used to fold prints also aids in unfolding or refolding prints. Figure 2.40 illustrates how to fold B, C, D, and E prints properly. You can apply similar techniques to metric and other sheet sizes.

## MICROFILM

**Microfilm** is photographic reproduction on film of a drawing or other document that is highly reduced for ease in storage and sending from one place to another. When needed, equipment is available for enlargement of the microfilm to a printed



**FIGURE 2.40** How to fold B-size, C-size, D-size, and E-size prints properly. © Cengage Learning 2012

copy. Special care must be taken to make an original drawing of the best possible quality. The reason for this is that during each generation, the lines and text become narrower in width and less opaque than the original. The term *generation* refers to the number of times a copy of an original drawing is reproduced and used to make other copies. For example, if an original drawing is reproduced on microfilm and the microfilm is used to make other copies, this is a *second generation* or *secondary* original. When this process has been done four times, the drawing is called a *fourth generation*. A true test of the original

drawing's quality is the ability to maintain good reproductions through the fourth generation of reproduction.

In many companies, original drawings are filed in drawers by drawing number. When a drawing is needed, the drafter finds the original, removes it, and makes a copy. This process works well, although drawing storage often becomes a problem, depending on the company's size or the number of drawings generated. Sometimes an entire room is needed for drawing storage cabinets. Another problem occurs when originals are used repeatedly. They often become worn and damaged, and

old vellum becomes yellowed and brittle. In addition, in case of a fire or other kind of destruction, originals can be lost and endless hours of drafting vanish. For these and other reasons, microfilm has been used for storage and reproduction of original drawings. ASME Y14.1 and ASME Y14.1M provide recommended microfilm reduction factors for different sheet sizes. These guidelines help ensure standardization.

Although microfilm storage of old drawings still exists in some companies, CADD files have replaced the use of microfilm for most modern applications.



## Digitizing and Scanning Existing Drawings

For information about digitizing and optically scanning existing drawings, go to the Student CD, select **Supplemental Material, Chapter 2**, and then **Digitizing and Scanning Existing Drawings**.

### CADD VERSUS MICROFILM

Microfilm was once an industry standard for storing and accessing drawings. Large international companies especially relied on the microfilm network to ensure that all worldwide subcontractors, vendors, clients, and others involved with a project were able to reproduce needed drawings and related documents. One advantage of microfilm was the ability to **archive** drawings—that is, store something permanently for safekeeping.

The use of CADD in the engineering and construction industries has made it possible to create and store drawings electronically on a computer, optical disk, or other media. This makes it possible to retrieve stored drawings easily and quickly. A big advantage of CADD file storage involves using CADD drawings. When you retrieve CADD-generated drawings, they are of the same quality as when they were originally drawn. You can use CADD drawings to make multiple copies or to redesign a product efficiently. In addition to the maintained original quality of the stored CADD drawing, the drawing file can be sent anywhere in the world over the **Internet** or within a company's **intranet**. The Internet is a worldwide network of communication between computers,

and an intranet links computers within a company or an organization.

### CAD/CAM

The optimum efficiency of design and manufacturing methods is achieved without producing a single paper copy of a drawing of a part. Computer networks can directly link engineering and manufacturing departments by integrating computer-aided design (CAD) and computer-aided manufacturing or machining (CAM) software. This integration is referred to as **CAD/CAM**. The drafter or designer creates a 3-D model or 2-D engineering drawing of a part using CADD software. CAM software is then used to convert the geometry to *computer numerical control* (CNC) data that is read by the numerically controlled machine tools. Often, the CAD/CAM system is electronically connected to the machine tool. This electronic connection is called *networking*. This direct link is referred to as *direct numerical control* (DNC), and it requires no additional media such as paper, disks, CDs, or tape to transfer information from engineering to manufacturing. You will learn more about CAD/CAM later in this textbook.

## PROFESSIONAL PERSPECTIVE

As you learn engineering drafting, take any opportunity you have to visit local companies and ask about the processes and standards they use to create drawings. Also ask to look at the drawings they create. The more real-world drawings you look at, the better you can understand what it takes to create a quality drawing. You can compare what is done in industry with what is described in this textbook. This textbook makes every effort to provide you with information, descriptions, and instructions needed to develop quality drawings based on industry standards. For example, this chapter provides

detailed information and examples related to sheet sizes, sheet blocks, and symbols. This content correlates the best interpretation of the ASME standards possible. When you look at actual industry drawing that follows standards and uses professional practices, you will notice the difference in drawings that are less than professionally prepared: There may be incomplete sheet blocks, drawings that are crowded and difficult to read, and other indications that the drawings probably do not follow proper standards. Take pride in your work when you become a professional drafter.

## ANGLE MEASUREMENT IN RADIANs

Although drafting machines, surveying instruments, and many modern machine tools work with units of degrees and minutes, many computer and calculator applications require angles to be measured in decimal fractions of a degree. It is important to be able to apply math to convert from one type of angle measurement to another because not all machines and computers do this automatically.

To convert from minutes of a degree to decimal degrees, divide the number of minutes by 60. For example,  $7^{\circ} 40'$  is the same as  $7.666666^{\circ}$ , or rounding,  $7.67^{\circ}$ , because  $40 \div 60 = .666666$ . To convert from decimal degrees to minutes, multiply the decimal portion of the angle by 60. For example,  $18.75^{\circ}$  is the same as  $18^{\circ} 45'$  because  $.75 \times 60 = 45$ .



For complete information and instructions for engineering drawing and design math applications, go to the Student CD, select **Reference Material** and **Engineering Drawing and Design Math Applications**.

## WEB SITE RESEARCH

Use the following Web sites as a resource to help find more information related to engineering drawing and design and the content of this chapter.

Address	Company, Product, or Service
<a href="http://www.asme.org">www.asme.org</a>	American Society of Mechanical Engineers (ASME)
<a href="http://www.chartpak.com">www.chartpak.com</a>	Chartpak manual drafting supplies and media
<a href="http://www.dlis.dla.mil">www.dlis.dla.mil</a>	United States Defense Logistic Service Center (DLSC)
<a href="http://www.govsupport.com">www.govsupport.com</a>	A source for CAGE code listed supplier parts and inventory

## Chapter 2

## Chapter 2 Drafting Equipment, Media, and Reproduction Methods Test



To access the Chapter 2 test, go to the Student CD, select **Chapter Tests and Problems**, and then **Chapter 2**. Answer the questions

with short, complete statements, sketches, or drawings as needed. Confirm the preferred submittal process with your instructor.



# Chapter 2 Drafting Equipment, Media, and Reproduction Methods Problems

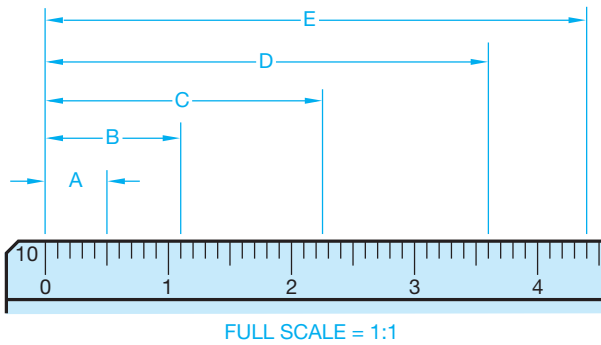
## Reading Scales and Drafting Machine Verniers

### Part 1: Problems 2.1 Through 2.9

Follow the instructions provided with each problem. Use a word processor to type your answers by giving the problem number, such as PROBLEM 2.1, with your answers for the following problems. Print and submit the answers to your instructor, unless otherwise specified by your instructor.

#### PROBLEM 2.1

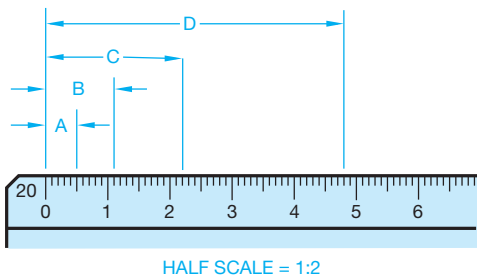
Given the following civil engineer's scale, determine the readings at A, B, C, D, and E.



© Cengage Learning 2012

#### PROBLEM 2.2

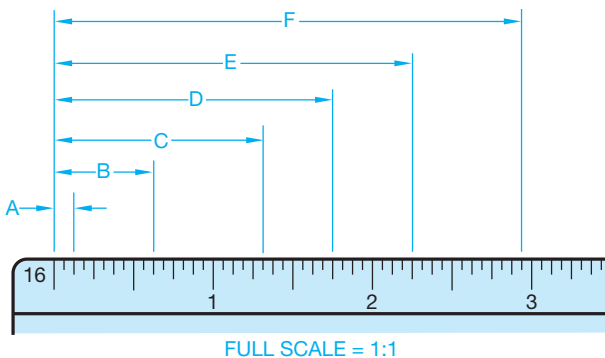
Given the following civil engineer's scale, determine the readings at A, B, C, and D.



© Cengage Learning 2012

#### PROBLEM 2.3

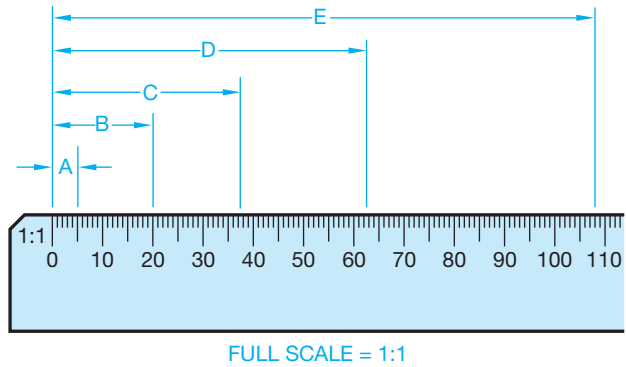
Given the following architect's scale, determine the readings at A, B, C, D, E, and F.



© Cengage Learning 2012

#### PROBLEM 2.4

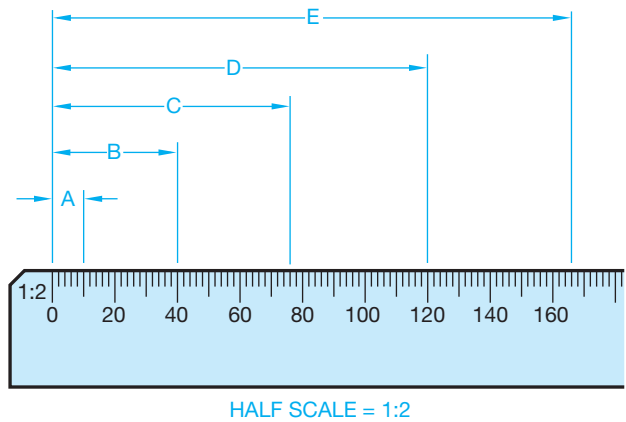
Given the following metric scale, determine the readings at A, B, C, D, and E.



© Cengage Learning 2012

#### PROBLEM 2.5

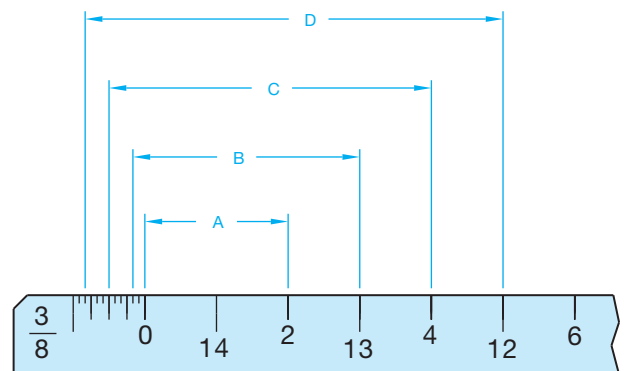
Given the following metric scale, determine the readings at A, B, C, D, and E.



© Cengage Learning 2012

#### PROBLEM 2.6

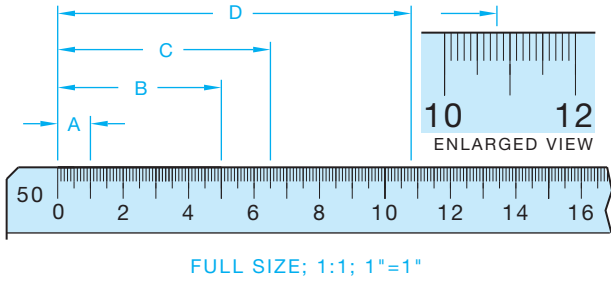
Given the following architect's scale, determine the readings at A, B, C, and D.



© Cengage Learning 2012

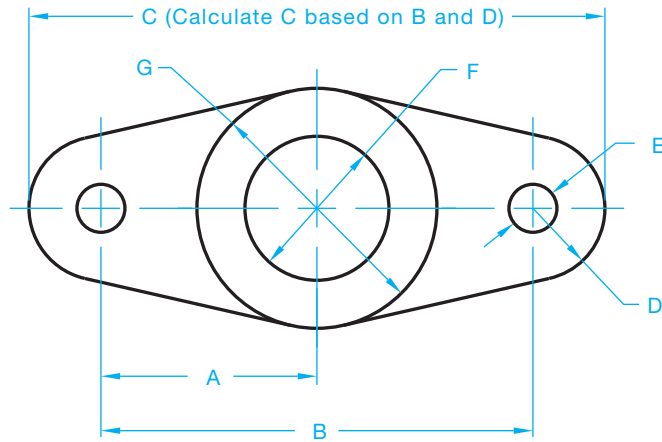
**PROBLEM 2.7**

Given the following mechanical engineer's scale, determine the readings at A, B, C, and D.



**PROBLEM 2.8**

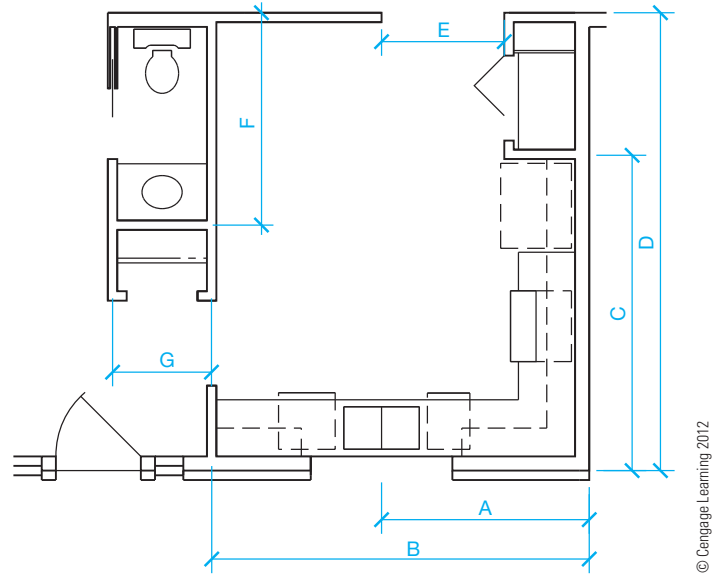
Given the following mechanical drawing, use the civil engineer's or mechanical engineer's 1:1 (10) scale to determine the dimensions at A, B, C (to be calculated as shown), D, E, F, and G.



**PROBLEM 2.9**

Given the following partial floor plan, use the architect's 1/4" = 1'-0" scale to determine the dimensions at A, B, C, D, E, F, and G.

**PROBLEM 2.9 (Continued)**



**Reading Sheet Blocks**

**Part 2: Problems 2.10 Through 2.26**

Given the following sheet blocks, with characteristics labeled A through Q, name and completely identify each characteristic. Use a word processor to type your answers by giving the problem number, such as PROBLEM 2.10, with your answers for the following problems. Print and submit the answers to your instructor, unless otherwise specified by your instructor.

- PROBLEM 2.10 (A)
- PROBLEM 2.11 (B)
- PROBLEM 2.12 (C)
- PROBLEM 2.13 (D)
- PROBLEM 2.14 (E)
- PROBLEM 2.15 (F)
- PROBLEM 2.16 (G)
- PROBLEM 2.17 (H)
- PROBLEM 2.18 (I)
- PROBLEM 2.19 (J)
- PROBLEM 2.20 (K)
- PROBLEM 2.21 (L)
- PROBLEM 2.22 (M)
- PROBLEM 2.23 (N)
- PROBLEM 2.24 (O)
- PROBLEM 2.25 (P)
- PROBLEM 2.26 (Q)

(C)	(M)	(A)
(P) UNLESS OTHERWISE SPECIFIED DIMENSIONS ARE IN INCHES (IN) (Q) TOLERANCES: 1 PLACE ±.1 2 PLACE ±.01 3 PLACE ±.005 4 PLACE ±.0050 ANGLES 30° FINISH 62 u IN	APPROVALS      DATE DRAFTER CHECKER ENGINEER	(D) <b>DELMAR</b> 5 Maxwell Drive CENGAGE Learning Clifton Park, NY 12065-2919 TITLE (E)
	THIRD ANGLE PROJECTION 	
(B)	(N) (O)	SCALE (J)      (K)      SHEET (L)

### Reading a Revision History Block

#### Part 3: Problems 2.27 Through 2.31

Given the following revision history block, with characteristics labeled 1 through 5, name and completely identify each characteristic. Use a word processor to type your answers by giving the problem number, such as PROBLEM 2.27, with your answers for the following problem. Print and submit the answers to your instructor, unless otherwise specified by your instructor.

PROBLEM 2.27 ①

PROBLEM 2.28 ②

PROBLEM 2.29 ③

PROBLEM 2.30 ④

PROBLEM 2.31 ⑤

### Math Problems

#### Part 4: Problems 2.32 Through 2.41

Convert the following angle measurements to decimal degrees.

PROBLEM 2.32 15'

PROBLEM 2.33 7°30'

PROBLEM 2.34 18°5'

PROBLEM 2.35 200°18'

PROBLEM 2.36 -13°42'

Convert the following angle measurements to degrees and minutes.

PROBLEM 2.37 60.4°

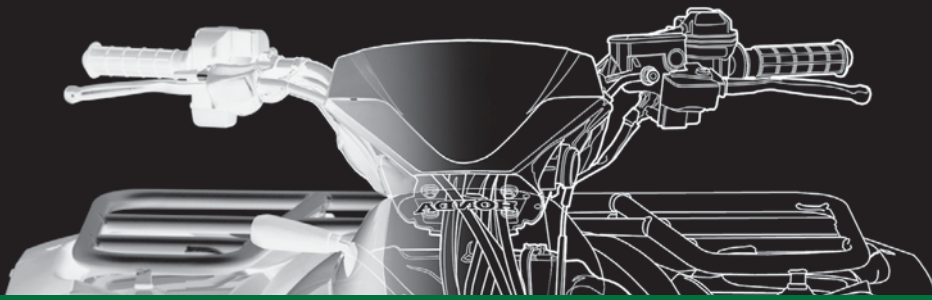
PROBLEM 2.38 9.5°

PROBLEM 2.39 .27°

PROBLEM 2.40 177.8°

PROBLEM 2.41 -45.1°

REVISION HISTORY				
ZONE	REV	DESCRIPTION	DATE	APPROVED
①	②	③	④	⑤



# CHAPTER 3

## Computer-Aided Design and Drafting (CADD)

### LEARNING OBJECTIVES

After completing this chapter, you will:

- Define CADD and CAD.
- Describe the CADD workstation and peripheral equipment.
- Identify common CADD software manufacturers and products.
- Describe and compare CADD formats.
- Identify disciplines and industry concepts related to CADD.
- Explain the use of animation and virtual reality in the design process.
- Demonstrate an understanding of basic CADD techniques, including drawing and editing, line standards and layers, reusing content, plotting, file templates, and storing and managing files.
- Explain basic surface and solid modeling techniques.
- Demonstrate an understanding of parametric solid modeling.
- Identify, describe, and use national CADD standards.
- Discuss issues related to productivity with CADD.
- Describe sustainable design and CAD practices.

## THE ENGINEERING DESIGN APPLICATION

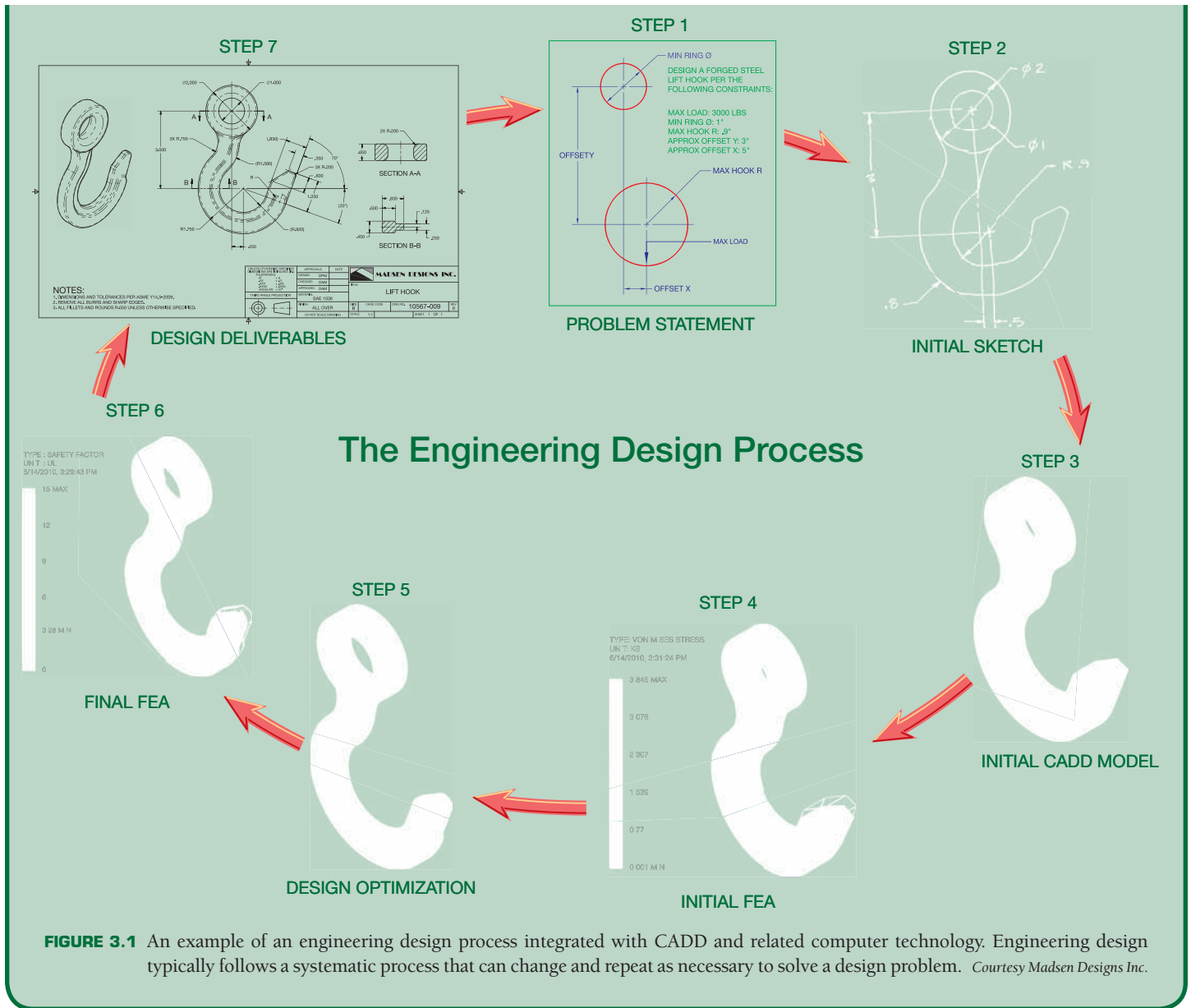
Computer-aided design and drafting (CADD) and related computer-aided technologies offer revolutionary tools for engineers and drafters to use during the engineering design process. CADD enhances design creativity, efficiency, and effectiveness when appropriately applied to product development. There are many different forms of accepted engineering design processes and integration of CADD within the engineering design process. Figure 3.1 shows a simplified sample of an engineering design process for a lift hook. The lift hook example and following information is an introduction to CADD in the engineering design process. You will learn more about CADD and related technology throughout this textbook.

Step 1 is to identify the problem and design **constraints**. A constraint is a condition, such as a specific size, shape, or requirement, that defines and restricts a design and must be satisfied in order to achieve a successful design. The problem statement in Figure 3.1, Step 1 describes the requirements and constraints for a forged-steel lift hook able to support a 3000-pound load. Step 2 is to sketch an initial design according to a possible solution to the problem. The sketch in Figure 3.1, Step 2, is hand drawn. You can use CADD as a sketching tool, and some CADD systems require you to create a digital sketch as an element

of the CADD process. However, hand-drawn sketches are common practice, especially during early design.

Step 3 is to generate the initial three-dimensional (3-D) computer-aided design (CAD) solid model according to the hand-drawn sketch. You can now study the model using **finite element analysis (FEA)** software. FEA applies the **finite element method (FEM)** to solve mathematical equations related to engineering design problems, such as structural and thermal problems. Figure 3.1, Step 4 shows a structural stress analysis applied to the lift hook to simulate a real-world lift.

Step 5 is to optimize the design to reduce material and improve shape while maintaining an acceptable working strength. You can perform design optimization using manual calculations and tests, repeated FEA simulation, or design-optimization software. Figure 3.1, Step 5 shows the optimized lift hook CAD solid model. Step 6 is to re-analyze the model to confirm a solution to the design problem. The final step is to use the CAD solid model to prepare two-dimensional (2-D) detail drawings and a digital format of the model supported by computer-aided manufacturing (CAM) software. The manufacturer uses the supplied data to create the forging equipment necessary to produce the lift hook.



## INTRODUCTION TO COMPUTER-AIDED DESIGN AND DRAFTING (CADD)

Computer-aided design and drafting (CADD) is the process of using a computer with CADD software for design and drafting applications. Software is the program or instructions that enable a computer to perform specific functions to accomplish a task. CADD refers to the entire range of design and drafting with the aid of a computer, from drawing basic 2-D objects to preparing complex 3-D models and animations. CAD is the acronym for computer-aided design and a common reference to computer-aided drafting. Computer-aided design and computer-aided drafting refer to specific aspects of the CADD process.

CADD offers solutions to most engineering drawing and design problems, and it allows for increasingly complex projects. Several industries and most disciplines related to engineering and architecture use CADD. Most engineering firms and educational institutions that previously used manual drafting practices have evolved to CADD. Professionals have come to rely on the power and convenience of CADD in all aspects of design and drafting. CADD systems include tools to accomplish any drawing and design requirement, such as preparing the 2-D drawing of a machine part shown in Figure 3.2 and the 3-D model of a home shown in Figure 3.3.

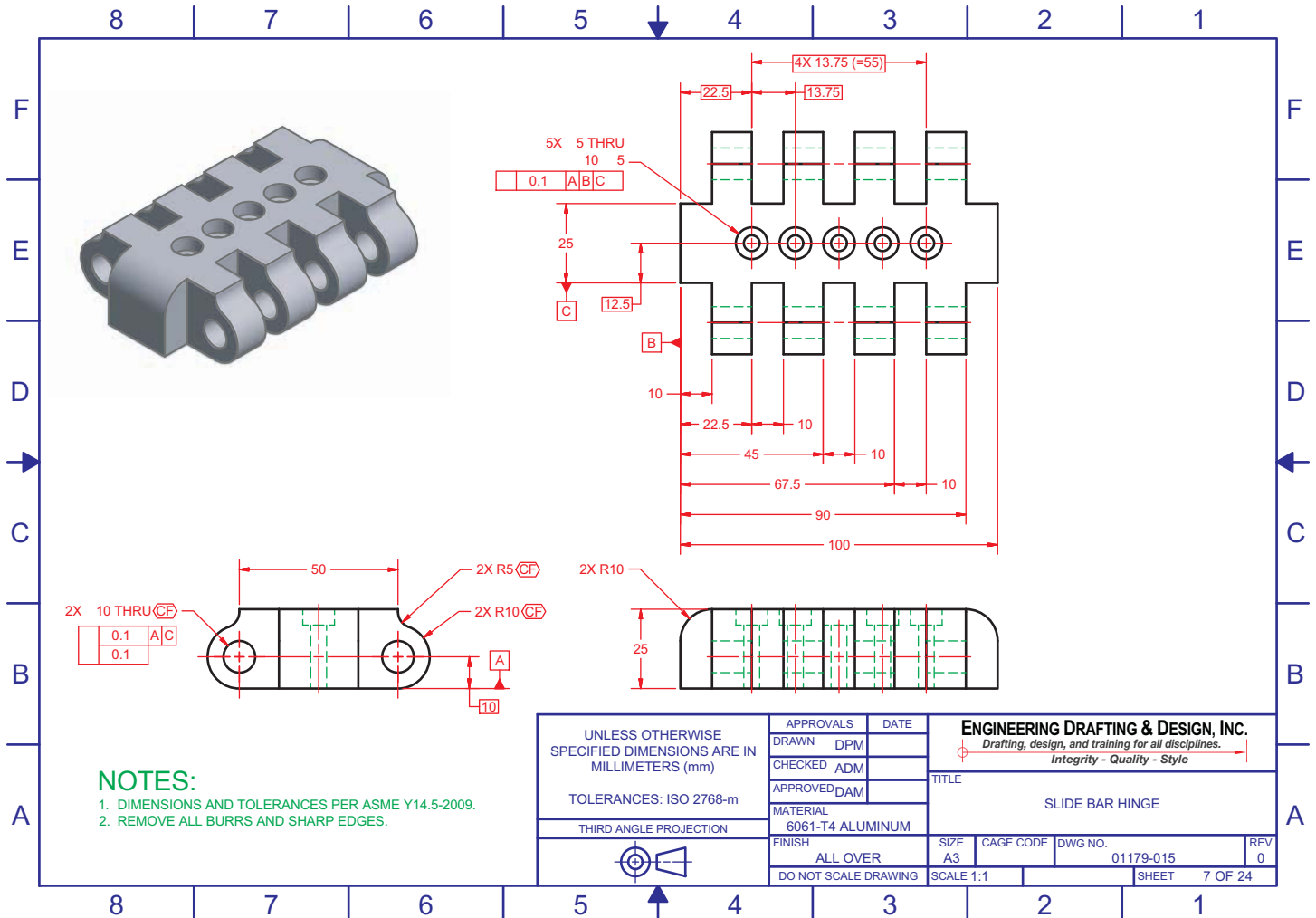


FIGURE 3.2 A 2-D detail drawing of a machine part drawn using CADD software. The drawing includes an isometric view with realistic surface color and shading. Courtesy Engineering Drafting & Design, Inc.

### THE CADD WORKSTATION

The CADD workstation consists of a variety of computer hardware. Hardware includes the physical components of a computer system, such as the computer, monitor, keyboard, mouse, and printer. Figure 3.4 shows a modern CADD workstation. A CADD workstation relies on a computer for data processing, calculations, and communication with peripheral equipment. A peripheral is an external computer hardware device that uses the computer to perform functions that the computer cannot handle.

Peripherals provide input, output, and storage functions and services. *Input* means to put information into the computer that the computer acts on in some way. Input comes from devices such as the keyboard, a mouse or similar input device, or a digitizer. *Output* refers to information that the computer sends to a receiving device such as a monitor, a plotter, or a printer. *Storage* refers to disks and drives that allow the operator to store programs, files, symbols, and data.

**CADD Hardware**

For more information about the CADD workstation and computer equipment, go to the **Student CD**, select **Supplemental Material, Chapter 3**, and then **CADD Hardware**.

### CADD SOFTWARE PRODUCTS

The modern CADD workstation is powerful, inexpensive, and supports sophisticated CADD software. Many CADD software manufacturers exist, and numerous products are available to meet industry needs. Some CADD software is general purpose and can apply to any discipline. For example, Autodesk, Inc. produces AutoCAD for 2-D and 3-D design and drafting. Other products focus on a specific CADD



Courtesy Alan Mascond Design Associates, Inc.

**FIGURE 3.3** A 3-D model of a home created using specialized architectural CADD software.



Pixtal Images/Photolibrary

**FIGURE 3.4** This CADD workstation has a computer, keyboard, mouse, and flat-panel monitor.

technology, industry, or discipline, such as drawings or models of mechanical parts and assemblies or those for architectural, civil, or structural engineering projects. For example, Dassault Systèmes SolidWorks Corp. offers SolidWorks for 3-D solid modeling and 2-D drafting that is common in the

manufacturing industry. Software specifically designed for CADD in the manufacturing industry is sometimes referred to as **mechanical computer-aided design (MCAD)** software. Some CADD programs support expanded, third-party, or add-on utilities intended to increase system usefulness for specific applications.

The CADD software industry changes constantly. Software manufacturers frequently update existing products or combine, change program names, or eliminate programs to adapt to the rapidly evolving CADD market. Software updates typically include additional and refined tools, increased software stability, and **graphical user interface (GUI)** enhancements. **Interface** describes the items that allow you to input data to and receive outputs from a computer system. The GUI provides the on-screen features that allow you to interact with a software program. New products regularly emerge to respond to innovative technology and project requirements. Larger software manufacturers, such as Autodesk Inc., Dassault Systèmes, Parametric Technology Corporation, and Siemens PLM Solutions hold the greatest number of CADD users, and they traditionally have the ability to expand their products and acquire smaller software companies or existing software.

Some software manufacturers offer products intended to support various aspects of product development. For example, some software companies combine CADD and CAM tools for design, drafting, and manufacturing. A few software companies offer specific applications or software packages to help manage all aspects of a project, known as product life cycle management (PLM). PLM systems include tools for CADD, product data management (PDM) to organize and monitor project data, computer-aided engineering (CAE) for simulation and analysis, CAM, and presentation. You will learn more about PLM and related technology throughout this textbook.



**NOTE:** The following is an alphabetical introduction to common CADD software manufacturers that describes selected software at the time of publication of this textbook. There are many other CADD software manufacturers and numerous other CADD software products. For more information, refer to the related Web sites at the end of this chapter, and search the Internet using keywords such as CAD, CADD, or CAD software. The following information and software content throughout this textbook are not intended to promote or endorse any software manufacturer or product.

### Alibre, Inc.

---

Alibre ([www.alibre.com](http://www.alibre.com)) provides software generally for CADD in the manufacturing industry. Alibre Design is a 3-D solid modeling and 2-D drafting program. The Professional version of Alibre Design includes tools for sheet metal design and rendering. The Expert version of Alibre Design provides additional functions such as simulation and FEA, PDM, CAM, and extended **translation** tools. Translation occurs when converting data from the file system of one CADD system to another, and it is often necessary when sharing CADD data with others, such as consultants, manufacturers, and vendors. Most CADD software includes tools for some level of file translation. Separate translation software is available when necessary. Alibre also offers Alibre Personal Edition, which is a 3-D modeling and 2-D drawing software marketed to hobbyists.

### Ashlar-Vellum

---

Ashlar-Vellum ([www.ashlar.com](http://www.ashlar.com)) offers basic 2-D and 3-D CADD software. Graphite provides 2-D and 3-D wireframe drawing and modeling capabilities. Argon is basic 3-D modeling software for conceptual design, visualization, and translation. Xenon and Cobalt, which include additional functions, are 3-D modeling programs with 2-D drafting capabilities.

### Autodesk, Inc.

---

Autodesk ([www.autodesk.com](http://www.autodesk.com)) offers a wide variety of software. AutoCAD is general-purpose 2-D and 3-D CADD software, and is the core Autodesk product. Autodesk provides

variations of AutoCAD for unique markets, such as AutoCAD LT for 2-D drafting, AutoCAD Electrical for electrical control system design, and AutoCAD Civil 3-D for civil engineering project design. Additional Autodesk products focus on specific CADD technology and industries, such as manufacturing, architecture, construction, infrastructure, media, and entertainment.

Autodesk® Inventor® is a 3-D solid modeling and 2-D drafting program generally for CADD in the manufacturing industry. Autodesk Inventor provides a comprehensive and flexible set of software for 3-D mechanical design, simulation, design visualization and communication, tooling creation, and 2-D documentation. Autodesk offers Autodesk Inventor Suites that combine Autodesk Inventor, AutoCAD Mechanical, and tools for specific applications, such as mold, tube and pipe, and cable and harness design. Some Autodesk Inventor Suites also include simulation and analysis functions. Autodesk Revit is a 3-D building design program with 2-D drafting and documentation capabilities. Versions of Autodesk Revit focus on design for architecture, mechanical, electrical, and plumbing (MEP), or building information modeling (BIM) for structural engineering. Autodesk manufactures numerous other software products, including Autodesk Algor Simulation for solid model simulation and FEA, Autodesk Vault for PDM, 3ds Max for 3-D modeling, animation, and rendering, and software to support sustainable and environmentally friendly design and development.

### Bentley Systems, Inc.

---

Bentley Systems ([www.bentley.com](http://www.bentley.com)) focuses on software for engineering and construction **infrastructure** design, documentation, and operation. Infrastructure is the structures, facilities, and services required for an economy to function, such as buildings, roads and bridges, water-supply and sewer systems, and power-supply and telecommunication systems. MicroStation is a general-purpose 2-D and 3-D CADD software and is the primary Bentley Systems product. MicroStation also acts as a platform for other Bentley Systems software. For example, GEOPACK Civil Engineering Suite includes tools for civil engineering and transportation project design. MicroStation PowerDraft is a version of MicroStation mainly for 2-D drafting. Bentley Systems manufactures other software, including ProjectWise for PDM, and ProConcrete for 3-D modeling, detailing, and scheduling of reinforced concrete structures.

### Dassault Systèmes

---

Dassault Systèmes ([www.3ds.com](http://www.3ds.com)) brands offer several software products generally focused on CAD and related technology for the manufacturing industry. CATIA is a project development system and is the main Dassault Systèmes brand



product. CATIA provides tools for 3-D solid modeling and 2-D drafting and tools for specific applications, such as mold, tube and pipe, cable and harness, and electronic design. CATIA also offers simulation and analysis, CAM, and PDM functions. The additional Dassault Systèmes brand software focuses on specific aspects of PLM.

SolidWorks is a 3-D solid modeling and 2-D drafting program and is the core Dassault Systèmes SolidWorks ([www.solidworks.com](http://www.solidworks.com)) brand product. Dassault Systèmes SolidWorks offers a standard version of SolidWorks and suites that incorporate SolidWorks with simulation, analysis, and PDM tools. SolidWorks Simulation includes tools for solid model simulation and FEA. SolidWorks Flow provides fluid-flow simulation and thermal analysis. Dassault Systèmes SolidWorks also manufactures software to support sustainable and environmentally friendly design and manufacturing.

## Google Inc.

---

Google SketchUp ([sketchup.google.com](http://sketchup.google.com)) is software intended to have an easy to use interface for creating, sharing, and presenting 3-D models. Common applications for Google SketchUp include sketching and modeling for visualization during the conceptual design phase of a project and creating presentation drawings that look hand sketched or photo realistic. Google SketchUp also links to Google Earth for sketching relative to a physical location, such as modeling a building on an actual lot.

## GRAPHISOFT

---

GRAPHISOFT ([www.graphisoft.com](http://www.graphisoft.com)) focuses on software for the architecture, engineering, and construction (AEC) industry. ArchiCAD is a 3-D building design program with 2-D drafting and documentation capabilities; it is the main GRAPHISOFT product. MEP Modeler adds 3-D and 2-D MEP functions to ArchiCAD. Virtual Building is a 3-D digital database that tracks all elements that make up a building, allowing the designer to use items such as surface area and volume, thermal properties, room descriptions, costs, product information, and window, door, and finish schedules. *Virtual* refers to something that appears to have the properties of a real or actual object or experience. GRAPHISOFT also manufactures photo-realistic rendering software and software to support sustainable and environmentally friendly architectural design and construction.

## IMSI/Design, LLC

---

IMSI/Design ([imsidesign.com](http://imsidesign.com)) offers basic CADD software for general-purpose and project-specific applications. TurboCAD is the core IMSI/Design product. IMSI/Design provides variations of TurboCAD for unique markets, such as TurboCAD Designer for 2-D drafting, TurboCAD Deluxe for 2-D drafting

and 3-D modeling, and TurboCAD Pro with additional 2-D and 3-D CADD functions. Additional IMSI/Design products focus on specific CADD technology and industries, such as Home & Landscape and Instant Architect for basic 2-D and 3-D home design.

## Intergraph

---

Intergraph ([www.intergraph.com](http://www.intergraph.com)) manufactures software for specific industries and projects, including the design, construction, and operation of plants, ships, offshore facilities, and transportation and utility systems. For example, SmartMarine 3-D is a specialized software for 3-D modeling, design, and documentation of marine structures, such as commercial ships. Intergraph also offers SmartSketch for 2-D drafting.

## IronCAD

---

IronCAD ([www.ironcad.com](http://www.ironcad.com)) provides software generally for CADD in the manufacturing industry. IRONCAD is a 3-D solid modeling and 2-D drafting program with PDM functions. A third-party application offers simulation and FEA tools compatible with IRONCAD. INOVATE is a version of IRONCAD with fewer 3-D modeling functions and no 2-D drafting capabilities.

## Kubotek Corporation

---

Kubotek ([www.kubotekusa.com](http://www.kubotekusa.com)) manufactures CADD and CAM software. KeyCreator is a 3-D solid modeling and 2-D drafting program generally for CADD in the manufacturing industry; it is the chief Kubotek product. Kubotek Validation Tool confirms design accuracy during or after a specific activity, such as a design revision or data translation. Kubotek also manufactures KeyMachinest for CAM and maintains CADKEY for 3-D wireframe modeling.

## Parametric Technology Corporation

---

Parametric Technology Corporation, or PTC ([www.ptc.com](http://www.ptc.com)), offers several software products generally focused on CADD in the manufacturing industry. Pro/ENGINEER is a 3-D solid modeling and 2-D drafting program and is the core PTC software. PTC provides various additions to the Pro/ENGINEER platform, including tools for CAE, CAM, and PDM: for example, Pro/ENGINEER Mechanica for simulation and FEA, Pro/ENGINEER Piping and Cabling Extension for pipe and cable design, and Pro/ENGINEER Reverse Engineering for automating **reverse engineering**. *Reverse engineering* is the process of converting an existing physical product into drawings or digital models, and it involves discovering the technological principles of a device, object, or system by analyzing its structure, function, and operation.

PTC manufactures other software, including Windchill for PDM, CoCreate for CAD, CAE, and PDM, and MathCAD for engineering calculations.

### Siemens Corporation

Siemens Corporation offers a wide variety of products and services. The Siemens PLM Solutions ([www.plm.automation.siemens.com](http://www.plm.automation.siemens.com)) brand manufactures PLM software. NX addresses each area of product development, and it is the primary Siemens PLM Solutions software. NX provides tools for 3-D solid modeling, 2-D drafting, and specific applications such as tool and fixture, routed system, and sheet metal product design. NX also offers simulation, FEA, CAM, and PDM functions. In addition to NX, Siemens PLM Solutions produces SolidEdge for 3-D solid modeling and 2-D drafting, generally for CADD in the manufacturing industry. The additional Siemens PLM Solutions brand software focuses on specific aspects of PLM.

### CADD FORMATS

There are several different CADD formats. The most recognized CADD formats include 2-D drawings and 3-D wireframe, surface, and solid models. In general, 2-D drawings and 3-D solid models are the most common CADD formats currently used in the industry. Three-dimensional surface models are also widely used, but often for specific applications. Three-dimensional wireframe models are rare in the current industry. Software specifies the CADD format, which usually focuses on a certain process such as 2-D drawing or 3-D solid modeling.

However, some systems offer tools for working in a variety of formats or the ability to use drawing or model content created in a different format. For example, you can often develop a 2-D drawing from 3-D model geometry or build a 3-D solid model from 3-D surface model geometry. A software add-on or separate application is sometimes required to work with multiple CADD formats.

### Choosing a CADD Format

Several factors influence CADD software and format selection. Design and drafting practices and specific project requirements are primary considerations. Two-dimensional drawings are often required because they are the standard format in manufacturing and construction. Figure 3.5 shows a 2-D structural detail required for the construction of a building. In addition, 2-D drawing is effective for a project that is quick to design, does not require extensive revision, and does not require advanced visualization, simulation, and analysis. Three-dimensional solid modeling is a better solution when a complex project will require extensive revision and when advanced visualization, simulation, and analysis are required. A 3-D representation of a design can help overcome visualization problems and produce a realistic, testable product model. Figure 3.6 shows a multidiscipline 3-D model of a building providing structural, electrical, HVAC, and piping layouts. When applied correctly, a combination of CADD formats and software may prove most effective for a project. Bringing the advantages of each CADD format together maximizes product design flexibility and effectiveness.

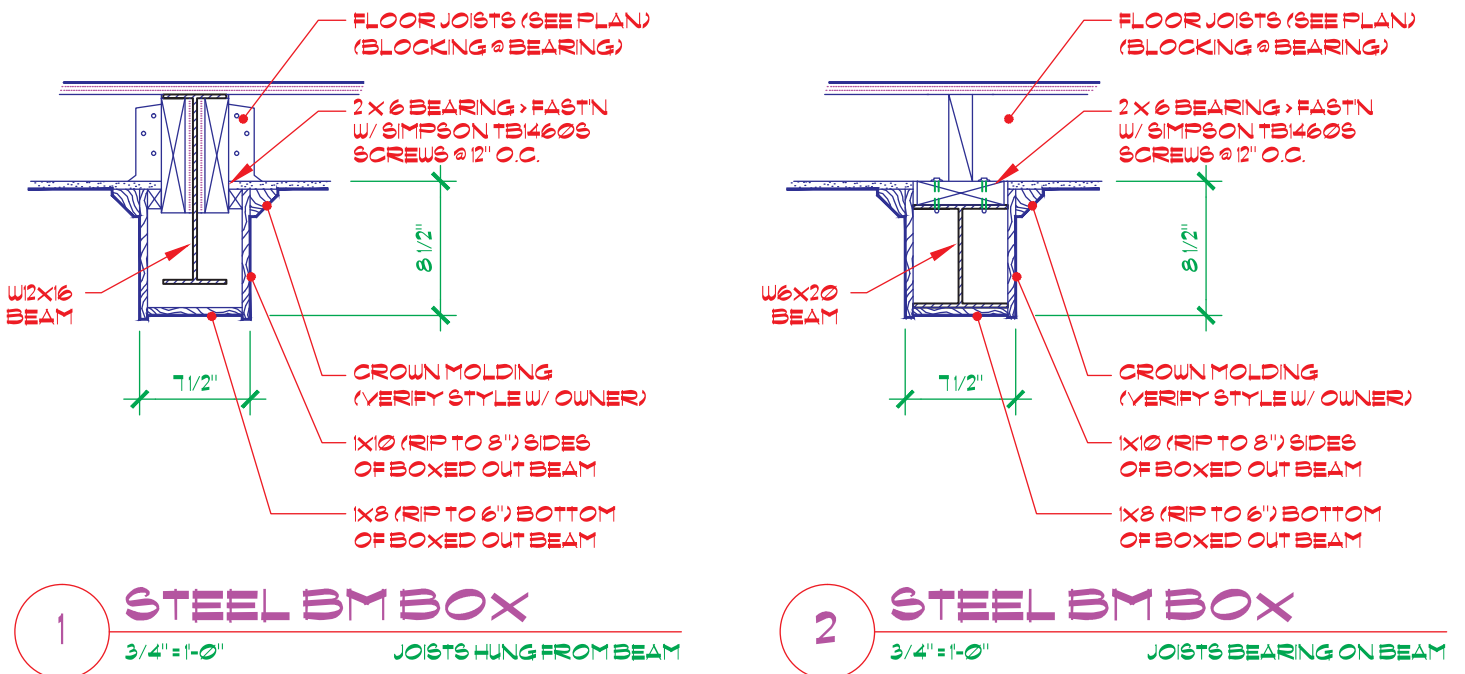
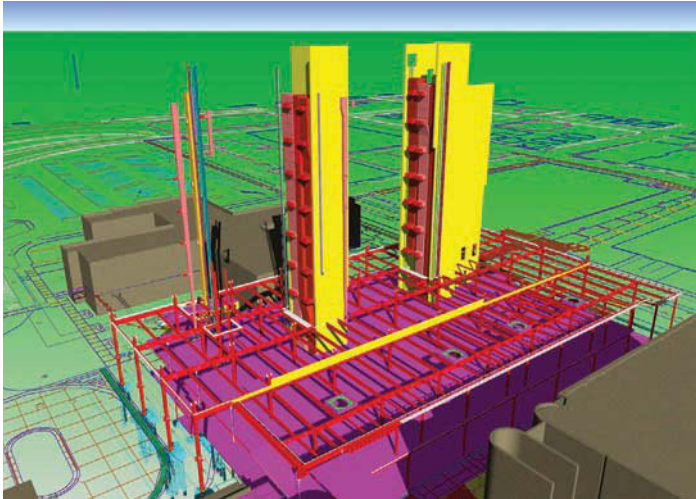


FIGURE 3.5 A 2-D structural detail required for the construction of a building. Courtesy Alan Mascord Design Associates, Inc.

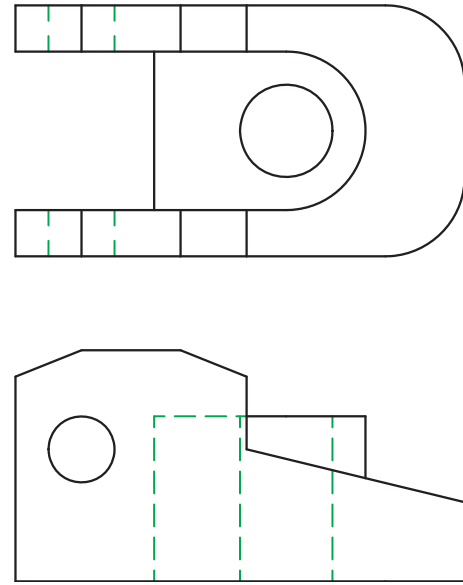


**FIGURE 3.6** A multidiscipline 3-D model of a building providing structural, electrical, HVAC, and piping layouts. *Courtesy Brad Dotson, B&D Consulting*

Collaboration and communication during a project also influence CADD software and format selection. Everyone involved in a project must be able to use a common CADD format or be able to easily convert data to a usable format. Costs are another important factor to consider when choosing a CADD software and format. For example, advanced 3-D solid modeling software is generally more expensive than 2-D drafting software. Operating a new or different CADD system also requires training and time to learn. Training is an expense and takes time from projects that produce income. A more capable CAD format, such as 3-D solid modeling, is extremely cost effective for some users, especially over time, but others will never benefit from the initial costs of the software and training. Several additional factors also influence selecting CADD software and format, including choosing a product and a format that is a known industry standard for project requirements, software stability and usability, the availability and effectiveness of support and training, and personal preference.

## Two-Dimensional Drawings

The abbreviation for **two-dimensional** drawing is 2-D, and it describes a view having only width and height, width and length, or height and length dimensions. Two-dimensional drawings are the established design and drafting format and are common in all engineering and architectural industries and related disciplines. Figure 3.7 shows a drawing with two 2-D views representing the geometry of an aircraft part. The two views together provide width, height, and length dimensions. Views appear in flat form and are normally rotated 90° from each other. A complete 2-D drawing typically includes dimensions, notes, and text that describes view features and details (see Figure 3.8).



**FIGURE 3.7** A 2-D view displays length and width, or width and height, dimensions. Multiple 2-D views may be necessary to describe an object.

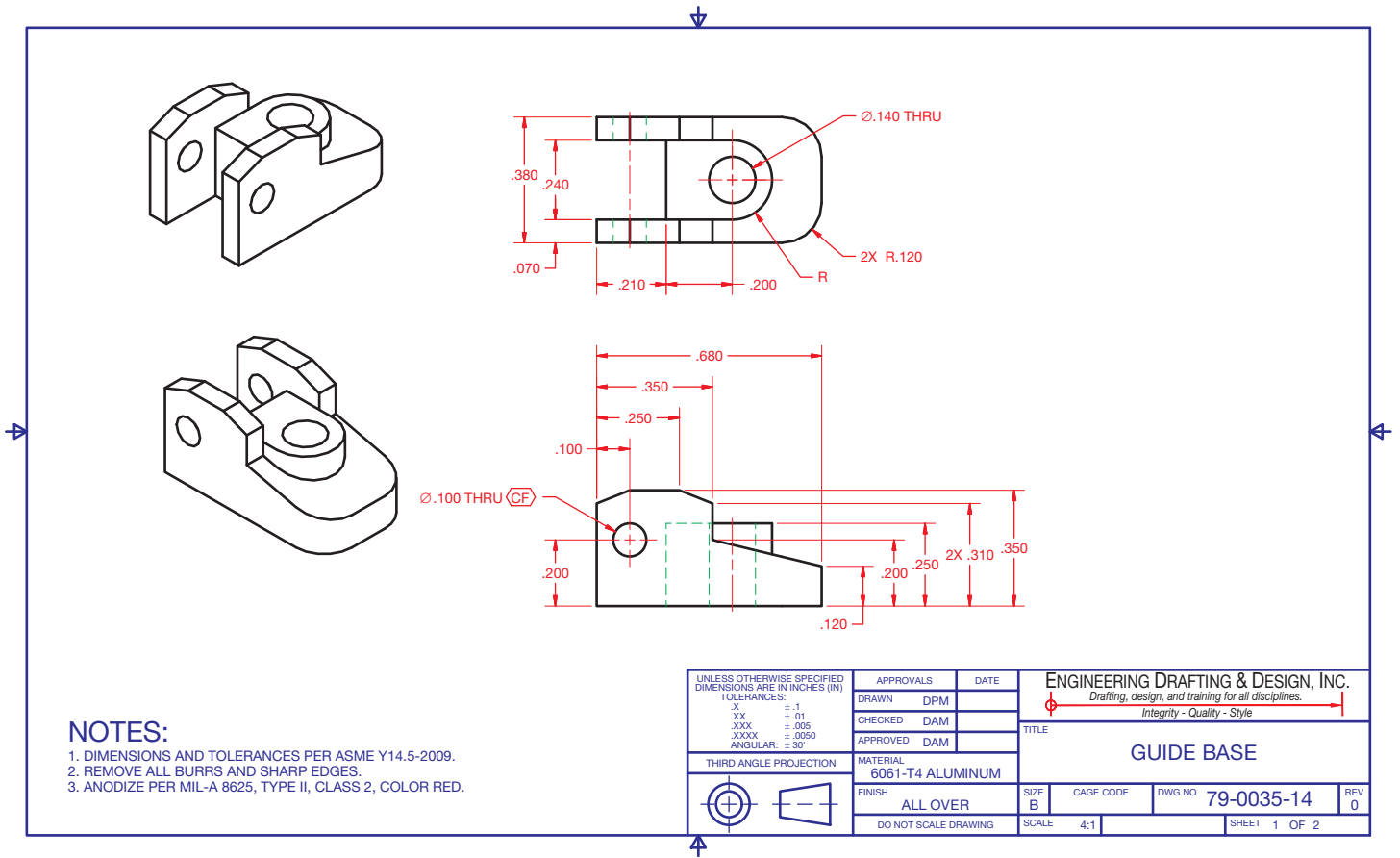
Courtesy Engineering Drafting & Design, Inc.

Two-dimensional drawings are the conventional and often required method of communicating a project. An effective 2-D drawing accurately describes design intent and product requirements, including the size, shape, and characteristics of all features, and materials, finishes, and manufacturing or construction methods. A 2-D drawing also typically documents additional project information, such as the individuals and companies involved with the project, relevant dates, approvals, and design revision history. Two-dimensional drawings can also provide computer numerical control (CNC) machine code. However, compared to 3-D surface and solid models, 2-D drawings offer fewer options for presenting and visualizing ideas and limited ability to analyze and test product design. In addition, 2-D drawings can sometimes be difficult to understand, especially if the reader is unfamiliar with interpreting 2-D drawings.

## Three-Dimensional Wireframe Models

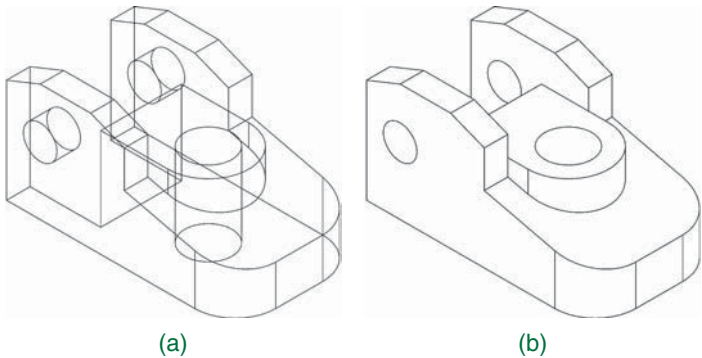
The abbreviation for **three-dimensional** is 3-D, and it describes an object having width, height, and depth dimensions. A **wireframe model** is the most basic 3-D CAD model, and it contains only information about object edges and vertices. The word *vertices* is plural for **vertex**, which is the point where edges intersect. The term *wireframe* describes the appearance of the model as if constructed from wires (see Figure 3.9a).

Three-dimensional surface and solid modeling has replaced wireframe modeling in the CAD industry. Wireframe models have limited use as models because they lack surfaces and mass. Without surfaces, wireframe models are difficult to visualize, create uncertainty about design intent, do not provide a true representation of a product, and lack volume. Some software offers the ability



**FIGURE 3.8** This is a complete 2-D drawing of an aircraft part with views, dimensions, notes, and text. This drawing includes 3-D representation, or pictorial, views that aid in visualization but that are still 2-D. *Courtesy Engineering Drafting & Design, Inc.*

to hide or change the format of the lines that fall behind object features to improve visualization and as a way to create a 3-D representation, or pictorial, view for a 2-D drawing (see Figure 3.9b). However, the display can still cause confusion, especially when viewing complex objects. Without volume or mass, wireframe models offer limited ability to analyze and test products.



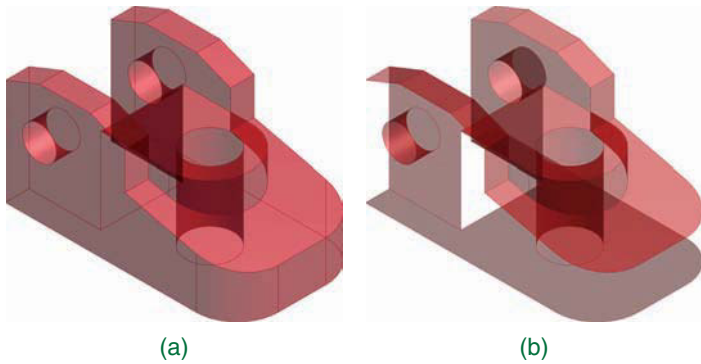
**FIGURE 3.9** (a) A wireframe model displays object edges and intersections of edges, or vertices. This is a wireframe model of the same part shown in 2-D views in Figures 3.7 and 3.8. (b) Hiding the lines that fall behind object features can improve visualization and create a 3-D representation for a 2-D drawing. *Courtesy Engineering Drafting & Design, Inc.*

A wireframe model does offer small file size and fast display regeneration, because the file only stores edge and vertex data. Wireframe models can also serve as a basis for constructing 3-D surface and solid models, and they can provide geometry for 2-D drawings. By rotating and repurposing a wireframe model, it is possible to produce the 2-D views shown in Figure 3.8. Wireframe models can also provide 3-D CNC machine code.

### Three-Dimensional Surface Models

A **surface model** contains information about object edges, vertices, and surfaces (see Figure 3.10). A **surface** is an outer boundary of an object that connects to edges and vertices. Surfaces can display color, shading, reflection, and texture that significantly improves visualization. Surfaces reduce uncertainty about design intent and provide a true representation of a product. Surface modeling also offers the ability to create complex curves and forms. Figure 3.11 shows an example of a surface model with photorealistic surfaces and complex forms.

Three-dimensional surface modeling is common in the CAD industry, particularly for industrial and conceptual design and to construct certain shapes. A surface model has zero thickness, lacks mass, and may not enclose a volume. Surface models allow for basic calculations such as surface area and volume, but



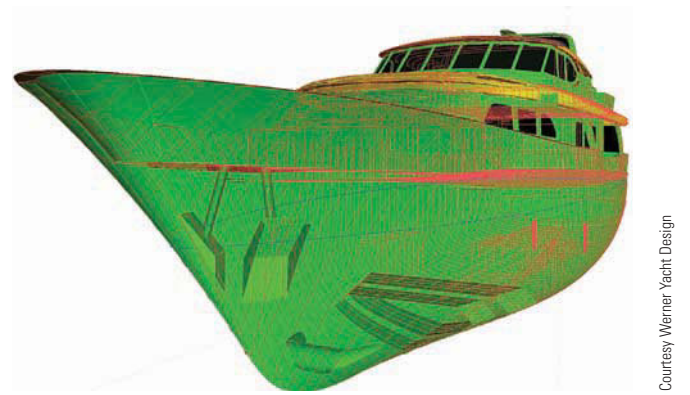
**FIGURE 3.10** (a) A surface model displays object surfaces. This is a surface model of the same part created as a wireframe model in Figure 3.9. (b) Removing or hiding surfaces illustrate the zero thickness of a surface model. *Courtesy Engineering Drafting & Design, Inc.*



**FIGURE 3.11** This surface model of a deep fryer includes complex forms and shapes and a realistic appearance. *Courtesy Unigraphics Solutions, Inc.*

without mass they offer limited ability to analyze and test physical and inertial properties. As a result, the most common users of surface models are designers who are primarily concerned with the external shape and appearance of a product. Boat and ship hull design is a common application for surface modeling (see Figure 3.12). An automobile body panel is another example of a product that requires accurate surfaces. Animations, video games, virtual reality programs, and programs with similar requirements often use surface models because of the ability to form complex surfaces, especially when solids are unnecessary and file size is generally smaller than solid model files.

Surface models can serve as a basis for constructing 3-D solid models, and they can provide geometry for 2-D drawings. By rotating and repurposing a surface model, it



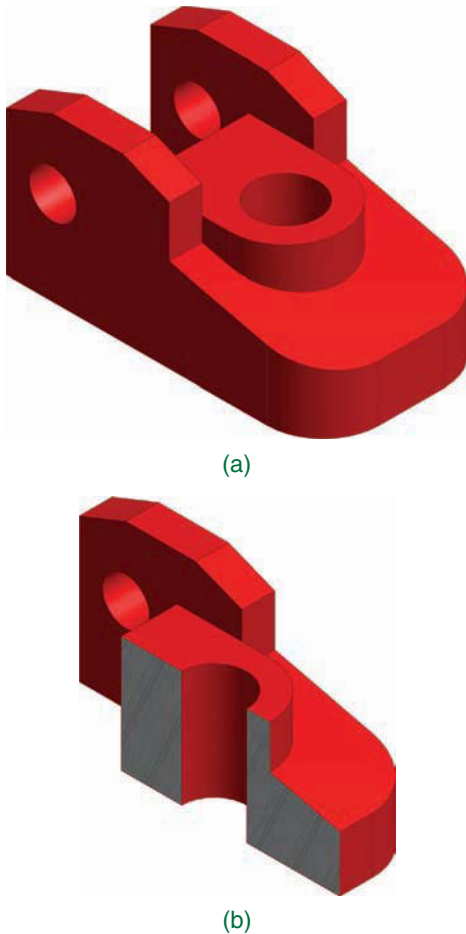
**FIGURE 3.12** Boat and ship hull design is a common application for surface modeling. The hull and additional structure of this yacht were designed using AeroHydro, Inc., MultiSurf surface modeling software. *Courtesy Werner Yacht Design*

is possible to produce the 2-D views shown in Figure 3.8 and display realistic surfaces on the 3-D representation, or pictorial, views. Surface models can also provide 3-D CNC machine code.

### Three-Dimensional Solid Models

A **solid model** is the most complex CAD format, and it contains information about object edges, vertices, surfaces, and mass (see Figure 3.13). An accurate solid model is an exact digital representation of a product. Like surface models, solid models can display surface color, shading, reflection, and texture for presentation and visualization. Figure 3.14 shows an example of a photorealistic solid model. Solid models also offer the ability to create intricate curves and forms. However, some designs require surface modeling in order to produce the desired form for a solid model. Some solid modeling software includes surface modeling tools to help model complex shapes that only surface modeling can produce or create efficiently.

Solid models are the most common 3-D CAD format used in the current CAD industry. A solid model encloses a volume and has mass, which allows designers and engineers to analyze exterior and interior object characteristics and perform interference and collision checks, mass calculations, and simulations. In contrast to a 2-D drawing that includes a note that specifies the material assigned to a product, and a 3-D surface model that displays a representation of material on surfaces, a 3-D solid model can be assigned a material that closely replicates the material used to manufacture the product. Assigning a material to a solid model allows for analyzing and testing physical and inertial properties. The result is a solid model that acts as a digital prototype of a product. You will learn more about assigning material to and analyzing a solid model throughout this textbook.



**FIGURE 3.13** (a) A solid model displays object surfaces and includes mass. This is a solid model of the same part created as a surface model in Figure 3.10. (b) Cutting through a solid model illustrates the solid interior.

Courtesy Engineering Drafting & Design, Inc.

Solid models can provide geometry for 2-D drawings. By rotating and repurposing a solid model, it is possible to produce the 2-D views shown in Figure 3.8 and display realistic surfaces on the 3-D representation or pictorial views. Solid models can also provide data for rapid prototyping and 3-D CNC machine code.

## INDUSTRY AND CADD

Drafting and graphic communication is just one CADD capability. Advanced CADD software allows you to develop and store many forms of data, such as engineering analyses, cost calculations, and material lists. In addition, CADD provides direct support to most areas of product development and production, including manufacturing, marketing, sales, service, and maintenance. Often all members of a product development team, from industrial designers to service technicians, create, use, or reference CADD data. Figure 3.15 shows an example of how CADD supports several elements of product design and manufacturing. The following information explores the concepts shown in Figure 3.15, and other elements related to industry and CADD.

## Product Life Cycle Management (PLM)

CADD is integral to stages of **product life cycle management (PLM)**. PLM is the method of managing the entire life cycle of a product from the initial concept through development and manufacture to discontinuing or replacing the product. Designers, engineers, and manufacturers use CADD for product design and manufacturing. Salespeople and marketers reference CADD data for product visualization and presentation. Service technicians use CADD data for product maintenance and disassembly. PLM helps coordinate these and all other areas of the product life cycle.

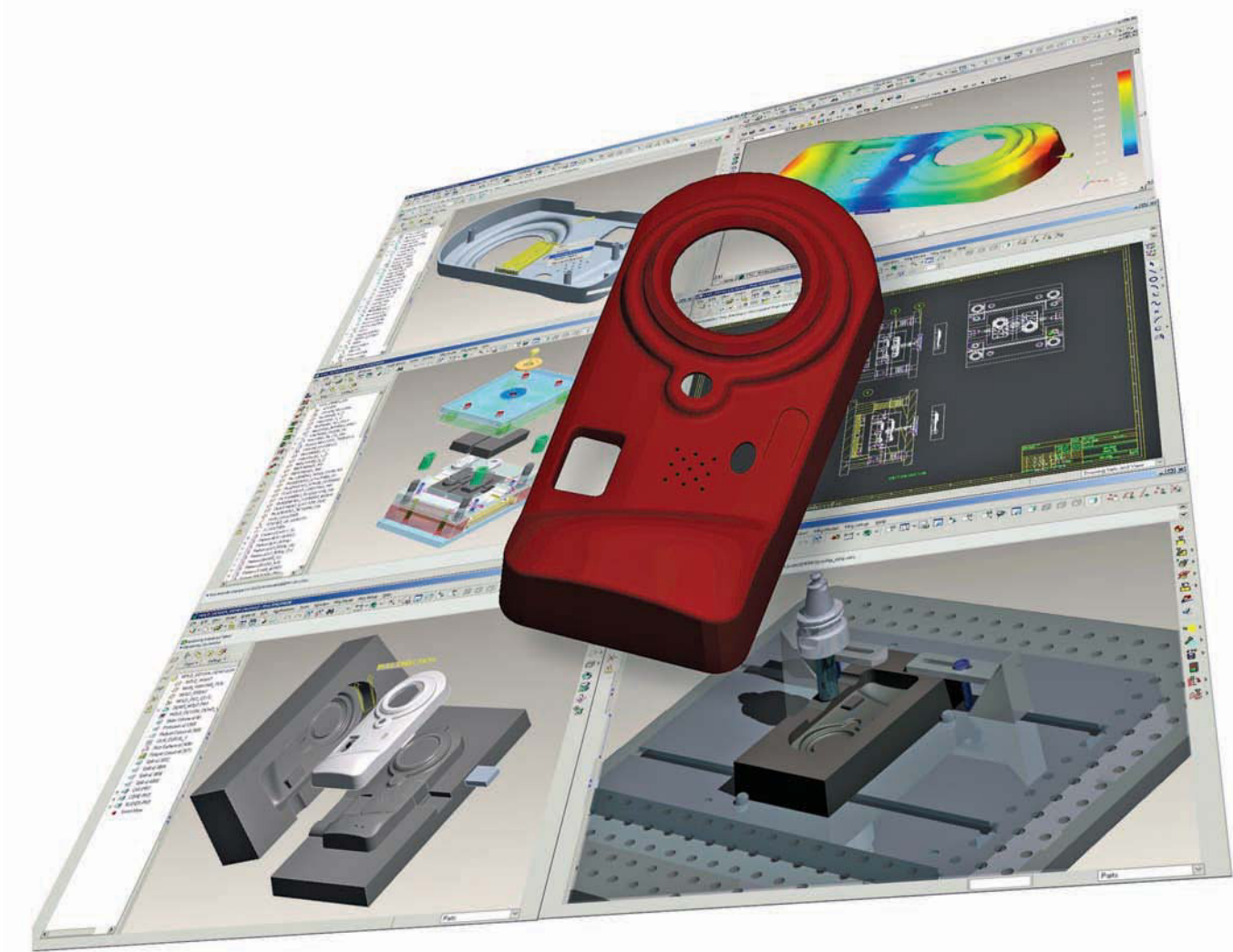
Some software companies offer PLM systems that include tools for CADD, product data management, computer-aided engineering (CAE), CAM, and presentation. **Product data management (PDM)** is the process of organizing and monitoring data related to a product, such as drawings, models, specifications, and other associated documents. Chapter 25, *The Engineering Design Process*, provides additional information about PLM.

## Web-Based Collaboration

Design and drafting is a cooperative process involving multiple disciplines. One of the most time-consuming and risky aspects of design and drafting is document management. The design process can require hundreds of drawings and documents. All of these documents can be in various states of completion. The coordination of this information is a big task. Web-based coordination uses the power of sophisticated PDM systems in conjunction with the Internet to simplify and streamline



**FIGURE 3.14** This solid model of a gas powered drill is an exact digital representation of the actual product. *Courtesy PTC*



Courtesy PTC

**FIGURE 3.15** A plastic part and corresponding injection mold designed using CADD. Advanced CADD software supports all elements of product development, including design, testing and analysis, tooling, documentation, presentation and visualization, and manufacturing.

document management and team communications. Database management products allow designers, drafters, product suppliers, manufacturers, contractors, and owners to communicate and coordinate throughout the entire project, regardless of the location of each participant.

Database management technology has implications for the production of design projects. Web-based coordination allows for the increased use of **outsourcing**, or sending elements of a project to subcontractors for completion. Outsourcing to multiple resources requires consistency in procedure and similarity in tools. Collaboration tools available today give designers a higher level of communication and control over the production process. E-mail allows tracking throughout the project. The new outsourcing model is based on defined tasks rather than hours worked. These discrete tasks are based on interrelated logical steps rather than drawing sheets. Drawings move forward according to their relationship to other drawings and the available information. The development of drawings and documents is treated

as stepped tasks or slices of time. Outsource personnel are independent professional subcontractors found all over the world, and connected through the World Wide Web (www). Through this huge network of potential workers, it is possible to find professionals who produce high-quality drawings on schedule and economically.

Web-based collaboration also affects the relationship of the designer and the client. The owner can view the progress of a project at any time because the work product is visible on the Internet. Progress on the documents is obvious, and the owner can involve more people in reviewing the work. This model of practice enhances the involvement of the owner in the process and improves the sense of overall teamwork.

## Prototyping

A **prototype** is a functional part model of a design; it is used as the basis for continuing the production of the final part or assembly. The terms prototype and **model** are often used

interchangeably. Prototypes are used to determine if a new design works as intended. A prototype is commonly used as part of the product design process to enable engineers and designers to explore design alternatives, determine unknown characteristics in the design, finalize part tolerances, confirm customer interest in the design, verify design performance, coordinate with marketing and sales, and test theories before starting full production of a new product.

A variety of processes can be used to create a prototype. The processes range from creating a digital model to developing a solid physical model of a part directly from a 3-D CAD model data and to fabricating a model using standard manufacturing processes. A company generally contracts with another company that specializes in developing prototypes quickly and accurately. Some companies have their own prototype development departments. A prototype is generally different from the final production part, because special processes and materials are used to quickly create a part that can be used to simulate the actual part.

The development phase of the design process is when a fully functioning prototype model is made that operates at the desired quality level. A physical prototype can be machined, molded, or created using rapid prototyping processes. Parts are assembled into the desired product and then tested to determine if the design meets specific product requirements such as weight and performance. The design might have to return to the concept phase for reevaluation if some aspects of the design do not perform as intended or manufacturing process appears to be too costly. After the functioning prototype has been built and tested, drawings are created for continuing to full production of the product.

## Digital Prototyping

A **digital prototype** is a computer-generated model or original design that has not been released for production. The most common and useful digital prototype is a 3-D solid model. A solid model digital prototype functions much like a physical prototype, is often just as or even more accurate, and can be subjected to real-world analysis and simulation. **Digital prototyping** is the method of using CAD to help solve engineering design problems and provide digital models for project requirements. Successful digital prototyping offers several benefits to the engineering design process. It provides companies with a deeper understanding of product function, enables the simulation of product performance as part of a complete system, offers interactive and automatic design optimization based on requirements, and assists other areas of product development and coordination.

Digital prototyping can support all members of a product-development team and help communication. Designers, engineers, and manufacturers use digital prototyping to explore ideas and optimize and validate designs quickly. Salespeople and marketers use digital prototyping to demonstrate and describe products. Depending on product requirements and



**FIGURE 3.16** Using digital prototyping to model, analyze, simulate, and visualize the operation of packaging equipment within a virtual packaging facility. *Courtesy Autodesk, Inc.*

company practices, digital prototyping can reduce or eliminate the need for physical prototypes, which are often expensive and time consuming to create and test. Figure 3.16 shows an example of digital prototyping to model, analyze, simulate, and visualize products in a virtual environment.

## Rapid Prototyping (RP)

**Rapid prototyping** is a manufacturing process by which a solid physical model of a part is made directly from 3-D CAD model data without any special tooling. An **RP model** is a physical 3-D model that can be created far more quickly than by using standard manufacturing processes. Examples of RP are **stereolithography (SLA)** and **fused deposition modeling (FDM)**, or **3-D printing**.

Three-dimensional CAD software such as AutoCAD, Autodesk Inventor, NX, Pro/Engineer, and SolidWorks allows you to export an RP file from a solid model in the form of an .stl file. A computer using postprocessing software slices the 3-D CAD data into .005–.013 in. thick cross-sectional planes. Each slice or **layer** is composed of closely spaced lines resembling a honeycomb. The slice is shaped like the cross section of the part. The cross sections are sent from the computer to the rapid prototyping machine, which builds the part one layer at a time.

The SLA and FDM processes are similar, using a machine with a vat that contains a photosensitive liquid epoxy plastic and a flat platform or starting base resting just below the surface of the liquid as shown in Figure 3.17. A laser controlled with bi-directional motors is positioned above the vat and perpendicular to the surface of the polymer. The first layer is bonded to the platform by the heat of a thin laser beam that traces the lines of the layer onto the surface of the liquid polymer. When the first layer is completed, the platform is lowered the thickness of one layer. Additional layers are bonded on top of the first in the same manner, according to the shape of their respective cross sections. This process is repeated until the prototype part is complete.

Another type of rapid prototyping called solid object 3-D printing uses an approach similar to inkjet printing. During the build process, a print head with a model and support print tip create the model by dispensing a thermoplastic material in layers.





Courtesy Stratagis, Inc.

**FIGURE 3.17** Following a tool path defined by the CAD file, the fused deposition modeling (FDM) system builds the model layer by layer. The build head extrudes molten thermoplastic in layers of .005–.010 in. with tolerances of up to .003 in.

The printer can be networked to any CAD workstation and operates with the push of a few buttons as shown in Figure 3.18.

Rapid prototyping has revolutionized product design and manufacture. The development of physical models can be accomplished in significantly less time when compared to traditional machining processes. Changes to a part can be made on the 3-D CAD model and then sent to the RP equipment for quick

reproduction. Engineers can use these models for design verification, sales presentations, investment casting, tooling, and other manufacturing functions. In addition, medical imaging, CAD, and RP have made it possible to quickly develop medical models such as replacement teeth and for medical research.

### Prototyping by Rapid Injection Molding

**Rapid injection molding** is an automated process of designing and manufacturing molds based on customer-supplied 3-D CAD part models. Because of this automation, lead time for the initial parts is cut to one-third of conventional methods. Cost saving varies with the number of parts being produced, but rapid injection molding can also have a substantial cost advantage in runs of up to thousands of parts. Rapid injection molding produces quality molds using advanced aluminum alloys and precise, high-speed CNC machining. Parts can be molded in almost any engineering grade resin. Figure 3.19 shows the 3-D CAD part model, the injection molded part in the mold, and the resulting rapid injection molded part.

### Subtractive Rapid Prototyping

CNC machining of parts has been around for decades, but the use has typically not been applied to short lead time prototype development. **Subtractive rapid prototyping** uses proprietary software running on large-scale computers to translate a 3-D CAD design into instructions for high-speed CNC milling equipment. The result is the manufacturing of small quantities of functional parts very fast, typically within one to three business days. A variety of materials, including plastics and metal, can be used with subtractive rapid prototyping. Figure 3.20 shows the 3-D CAD part model, the CNC machining process, and the machined part.



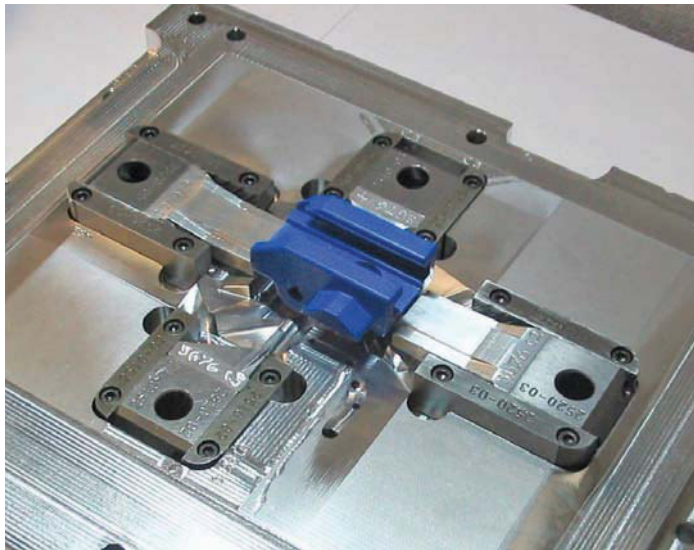
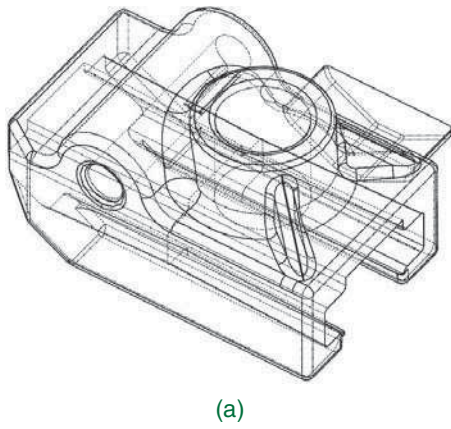
(a)



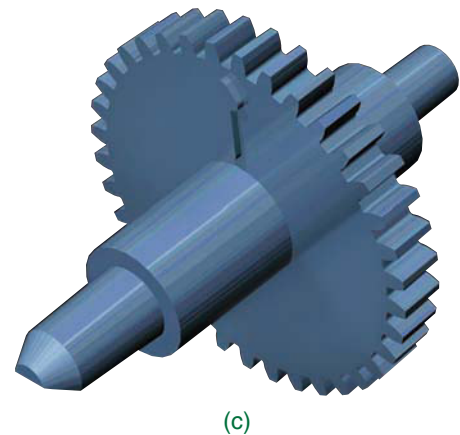
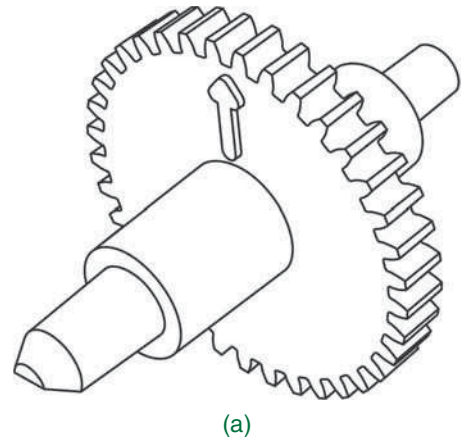
(b)

Courtesy 3-D Systems

**FIGURE 3.18** The 3-D printer uses a print head with a model and support print tip to create the model by dispensing a thermoplastic material in layers. (a) A designer holds a mobile phone cover printed on the ProJet line of professional 3-D printers. (b) The mobile back cover has been painted.



**FIGURE 3.19** (a) The 3-D CAD wireframe part model. (b) The injection molded part in the mold. (c) The resulting rapid injection molded part. *Courtesy Proto Labs, Inc.*



**FIGURE 3.20** (a) The 3-D CAD part model. (b) The CNC machining process. (c) The machined part. *Courtesy Proto Labs, Inc.*

## Prototyping by Conventional Machining

Some companies have a machine shop combined with the research-and-development (R&D) department. The purpose of the machine shop is to create prototypes for the engineering designs. Drafters generally work with engineers and highly skilled machinists to create design drawings that are provided to the machine shop for the prototype machining. This practice generally takes longer than the previously described practices, but the resulting parts can be used to assemble a working prototype of the product for testing.

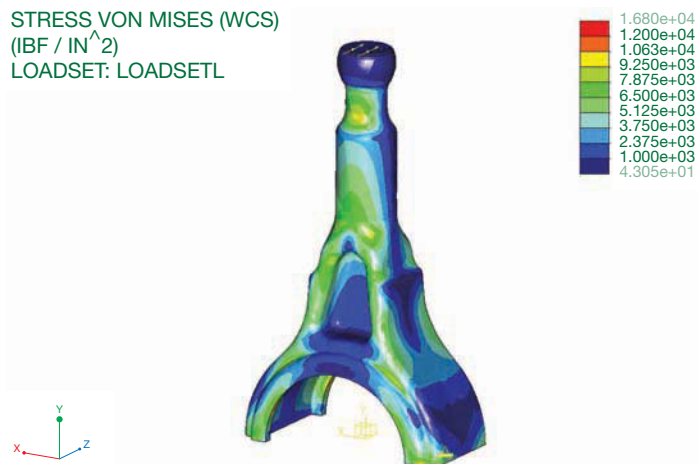
## Computer-Aided Engineering (CAE)

**Computer-aided engineering (CAE)** is the method of using computers in design, analysis, and manufacturing of a product, process, or project. CAE relates to most elements of CADD in industry. CAE is often recognized as the umbrella discipline that involves several computer-aided technologies including, but not limited to, CAD, computer-aided industrial design (CAID), CAD/CAM, CNC, CIM, and PDM, plus the Internet and other technologies to collaborate on projects.

CAE often focuses on mechanical design and product development automation. Some of the most familiar elements of CAE are surface and solid modeling and the simulation, analysis, testing, and optimization of mechanical structures and systems using digital prototypes. FEA is a process often associated with CAE. Figure 3.21 shows a 3-D solid model being subjected to simulated tests and stress analysis. The Engineering Design Application at the beginning of the chapter, and the Green Technology Application later in this chapter provide additional examples of CAE applications.

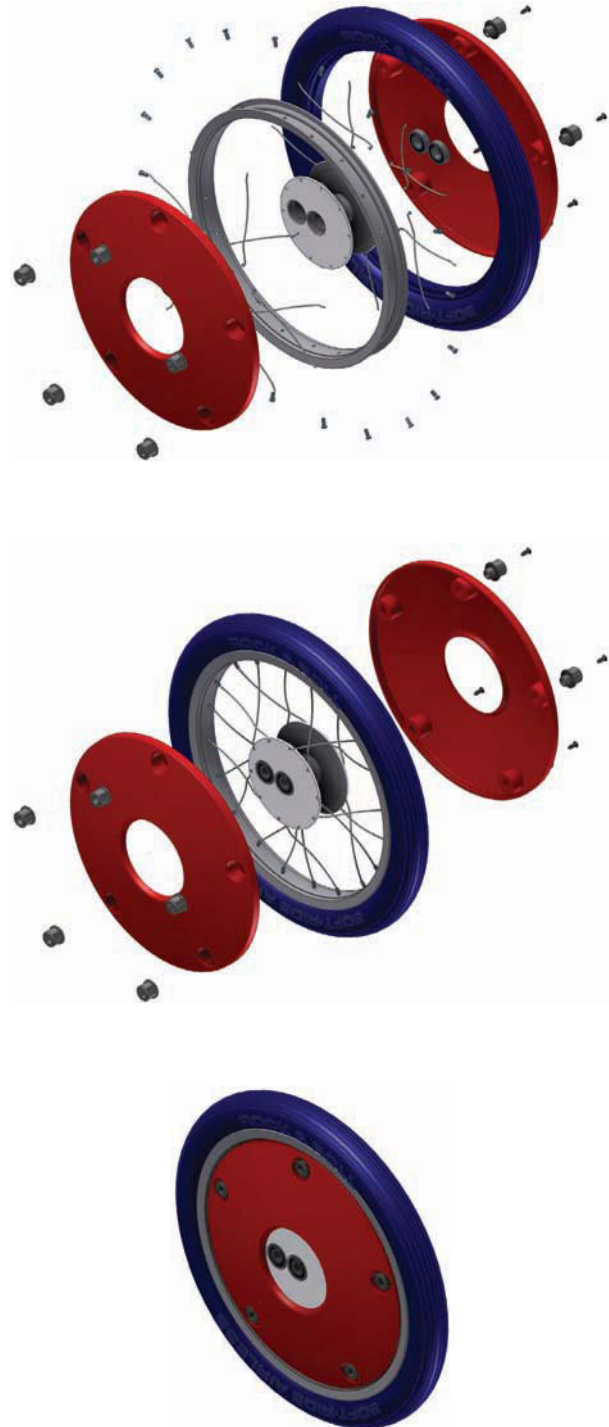
## Animation

**Animation** is the process of making drawings or models move and change according to a sequence of predefined images.



**FIGURE 3.21** CAE technology allows designers and engineers to subject a virtual prototype, such as this 3-D solid model of a part, to simulated tests and stress analysis. *Courtesy Milwaukee Electric Tool Corporation*

Computer animations are made by defining, or recording, a series of still images in various positions of incremental movement; when played back, the series no longer appears as static images but as an unbroken motion. Figure 3.22 provides an example of three images taken from an animation of a solid model assembly process. Based on the still images shown, try to imagine what the complete animation looks



**FIGURE 3.22** Three images taken from an animation of an assembly process. *Courtesy 2-Kool, Inc.*

like as the components come together to build the assembly. Animation is a broad topic with a variety of applications for different requirements, including engineering, education, and entertainment.



### Three-Dimensional Animation

To view the animation of the solid model assembly process shown in Figure 3.22, go to the Student CD, select **Supplemental Material, Chapter 3**, and then **Solid Model Assembly Process**.  
*Courtesy 2-Kool Inc.*

### Engineering Animations

Animations are a basic element of product design and analysis, and they are often useful for other stages of the engineering design process. Animations help explain and show designs in ways that 2-D drawings and motionless 3-D models cannot. Companies often use animations to analyze product function, explore alternative designs and concepts, and effectively communicate design ideas to customers. For example, moving, dragging, or **driving** solid model parts and subassemblies is an effective way to explore the motion and relationship of assembly components. Figure 3.23 shows still images from an animation of an engine crankshaft and pistons. The animation helps designers understand how components move and function, and it is used for analysis and simulation, such as to detect interference between components and evaluate stresses.

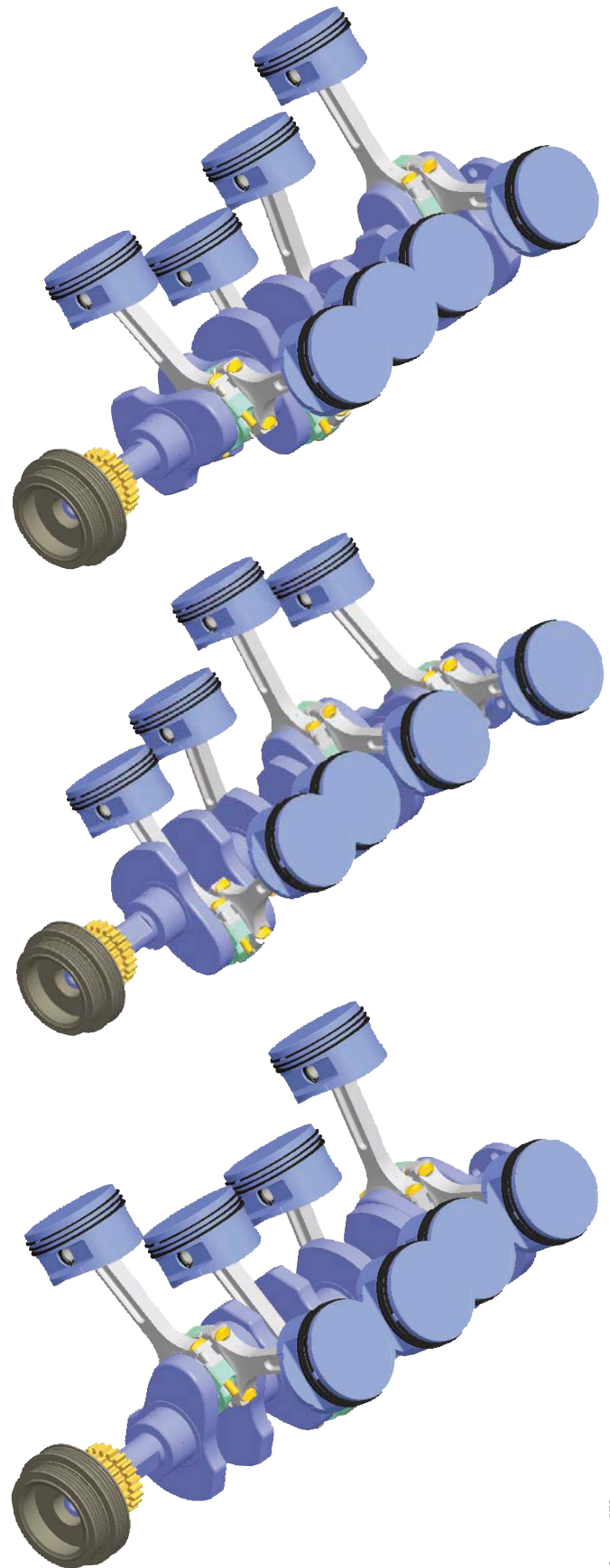


### Three-Dimensional Animation

To view an animation of a solid model stress analysis, go to the Student CD, select **Supplemental Material, Chapter 3**, and then **Solid Model Stress Analysis**.  
*Courtesy AntWorks Engineering Pty. Ltd. (antworks.com.au).*

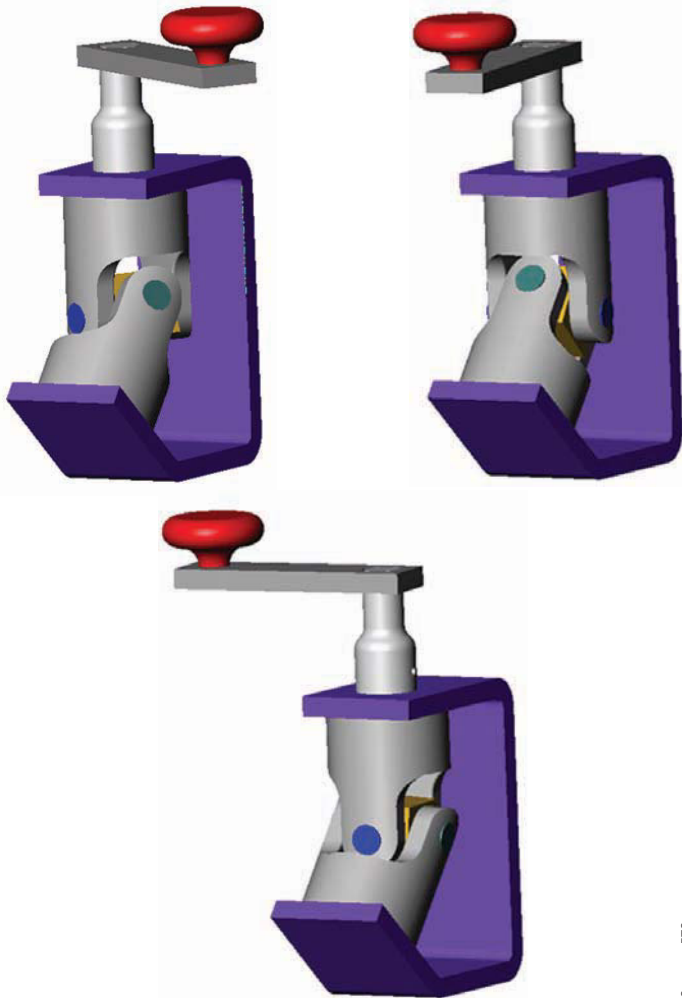
**Inverse kinematics (IK)** is a method used to control how solid objects move in an assembly. IK joins solid objects together using natural links or joints such as that illustrated in the sequence of frames of the universal joint shown in Figure 3.24. For example, IK relationships can lock the rotation of an object around one particular axis. Adding this type of information allows the solid assembly to move as the finished product would move. IK is used extensively to animate human and mechanical joint movements. Building and simulating an IK model involves a number of steps, including:

- Building a solid model of each jointed component.
- Linking the solid model together by defining the joints.



**FIGURE 3.23** Three images taken from an animation showing the dynamic movement of a crankshaft and pistons.

Courtesy PTC



Courtesy PTC

**FIGURE 3.24** An example of inverse kinematics (IK) used to animate a universal joint constrained around its axis. When the crank handle is turned, the constrained assembly rotates appropriately.

- Defining the joint behavior at each point, such as direction of rotation.
- Animating the IK assembly using an animation sequence.

## E-Learning Animations

Computer animations are a great tool for educators. Teachers and trainers create e-learning animations that can be used as an additional learning tool in the classroom or as an online or distance-learning presentation. Many companies and agencies use animations and simulations as an important part of their training routines. Examples of e-learning animations include corporate and military training activities, repair procedures, and complex simulations. For example, Figure 3.22 shows still images taken from a full-length video of the assembly and disassembly of a product, which is an impressive tool for training assembly workers.

## Entertainment

Entertainment is a well-known application for computer animations. The movie and television industries use computer animations heavily to add visual effects. In fact, some animated movies and television programs are created entirely using computer animation technology. Animations also provide the foundation for developing computer and video games. The increasing complexity of computer animation is resulting in video games that are more realistic and more exciting than ever before.

## Animation Techniques

Animations can range from the simple movement of solid model components in an assembly to large-scale videos or presentations with dialogue, music, and a variety of graphics. Many CADD programs, especially parametric solid modeling software, contain tools and options that allow you to generate basic animations. Other systems, such as Autodesk 3ds Max and VIZ, contain advanced animation tools that let you render solid models into very realistic 3-D motion simulations. Designated animation programs like Autodesk Maya and Maxon Cinema 4D are typically used for e-learning projects, films, and games. These programs are specifically designed for realistic animations, renders, character creation, and rigging. Animators commonly import CADD models into animation software, sometimes removing unnecessary engineering data to allow for practical and smooth animation. However, it is often more efficient to re-create models in the animation software for a better animation or render.

It is always a good idea to do some preproduction work before you record an animation. **Storyboarding** is a process by which you sketch out the key events of the animation. These sketches help ensure that key scenes are included to complete the story or demonstration. Video producers use storyboarding to preplan their production to help reduce costly studio editing time. Advanced rendering can take days to complete even on a high-speed computer. If scenes are left out of the animation, then the animation has to be redone, costing significant time and money. Renderings, like video productions, are different from live-action film productions where improvising takes place. Improvising does not occur during animation rendering, and therefore it must be precisely planned.

When storyboarding an animation, keep the focus on your audience. This focus should include the overall length of the animation, key points that must be demonstrated, and how these key points are to be best illustrated. Storyboarding is a simple process that can be done on note cards or plain paper. Include sketches of the key scenes that show how these events should be illustrated and the time allotted for each.

Most rendering software allows you to preview the animation sequences before rendering is executed. This feature is a good way to verify that an animation meets your expectations. When finished, select a rendering output file format and instruct the software to render your animation to a file. Animation software renders to a number of different file formats that allow for convenient playback. Common files formats are AVI, MPEG, QuickTime, and WAV.



## Three-Dimensional Animation

To view the following animations, go to the Student CD, select **Supplemental Material, Chapter 3**, and then:

- Automotive.
- BMX Engine.
- Chute Billie.
- Medical (*all courtesy PTC*).

## Computer-Aided Manufacturing (CAM)

**Computer-aided manufacturing (CAM)** uses computers to assist in the creation or modification of manufacturing control data, plans, or operations and to operate machine tools. Computers are integral to the manufacturing process. Computerized tools such as welding machines, machining centers, punch press machines, and laser-cutting machines are commonplace. Many firms are engaged in **computer-aided design/computer-aided manufacturing (CAD/CAM)**. In a CAD/CAM system, a part is designed on the computer and transmitted directly to computer-driven machine tools that manufacture the part. Within the CAD/CAM process, there are other computerized steps along the way, including the following:

- STEP 1** The CAD program is used to create the product geometry. The geometry can be in the form of 2-D multi-view drawings or 3-D models.
- STEP 2** The drawing geometry is used in the CAM program to generate instructions for the CNC machine tools. This step is commonly referred to as *CAD/CAM integration*.

**STEP 3** The CAM program uses a series of commands to instruct CNC machine tools by setting up tool paths. The tool path includes the selection of specific tools to accomplish the desired operation.

**STEP 4** The CAM programmer establishes the desired tool and tool path. Running the **postprocessor** generates the final CNC program. A postprocessor is an integral piece of software that converts a generic, CAM system tool path into usable CNC machine code (G-code). The **CNC program** is a sequential list of machining operations in the form of a code that is used to machine the part as needed.

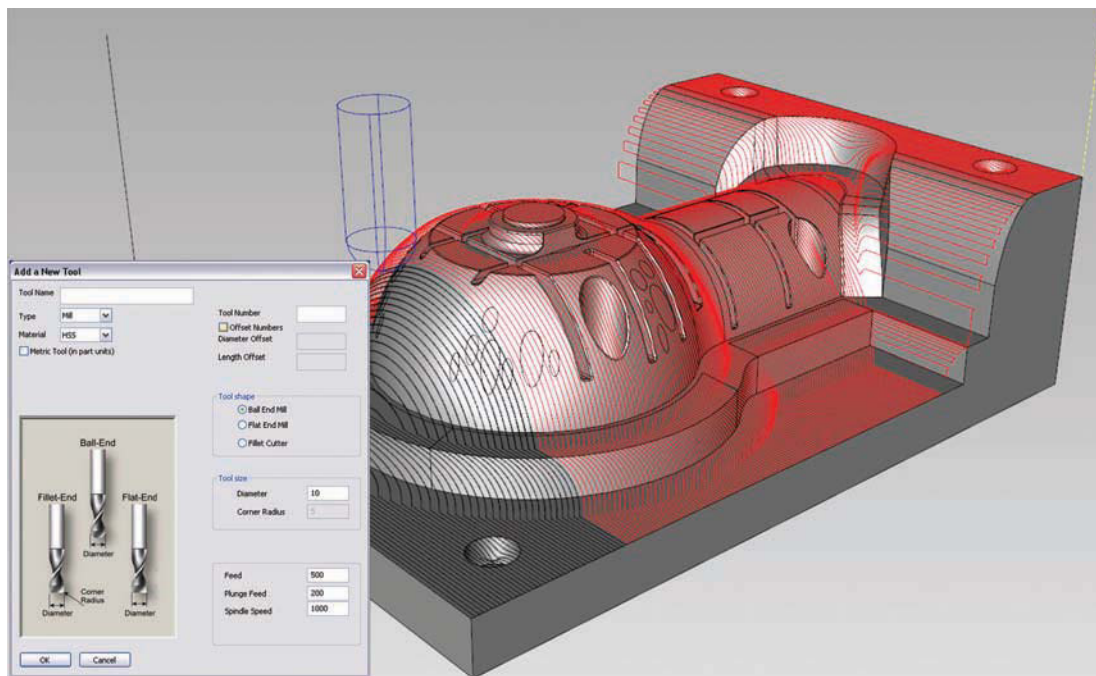
**STEP 5** The CAM software simulator verifies the CNC program (see Figure 3.25).

**STEP 6** The CNC code is created. Figure 3.26 illustrates the CADD 3-D model, the tool and tool holder, the tool path, and the G-code for machining a part.

**STEP 7** The program is run on the CNC machine tool to manufacture the desired number of parts.

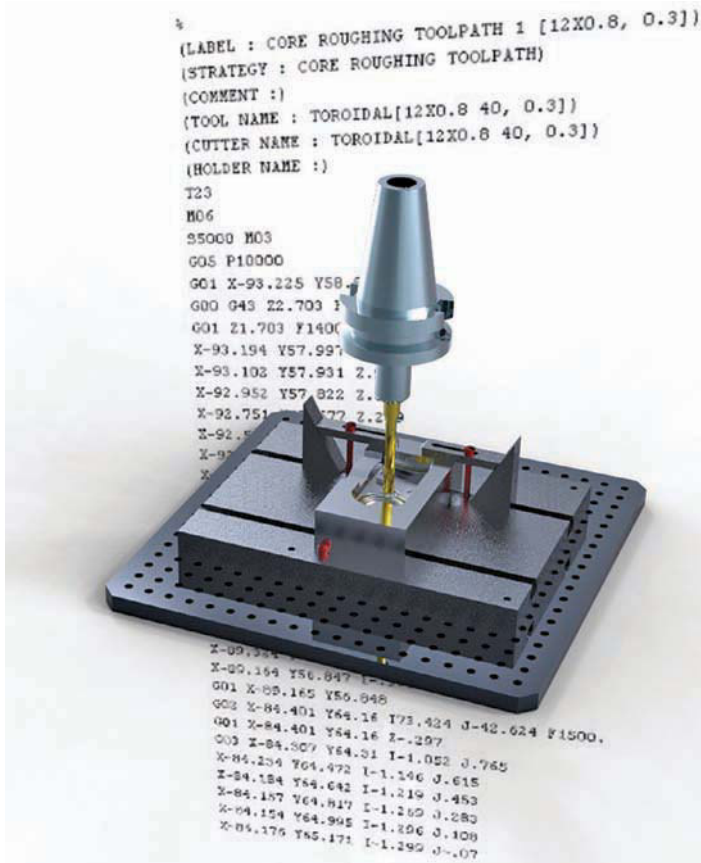
## Computer Numerical Control

**Computer numerical control**, also known as **numerical control (NC)**, is the control of a process or machine by encoded commands that are commonly prepared by a computer. CNC is a critical aspect of CAM in which a computerized controller uses motors to drive each axis of a machine such as a mill to manufacture parts in a production environment. The motors of the machine rotate based on the direction, speed, and length of time that is specified in the CNC program file. This file is created by a programmer and contains programming language used to establish



**FIGURE 3.25** This screen display illustrates using a CAM software simulator to verify the CNC program.

Courtesy Kubotek, USA



**FIGURE 3.26** A CADD 3-D model, the tool and tool holder, the tool path, and the G-code for machining a part. *Courtesy PTC*

the operation performed on the machine tool. Examples of CNC programming language include **G-codes**, which are primary functions such as tool moves, and **M-codes**, which are miscellaneous functions such as tool changes and coolant settings.

CNC is a major innovation in manufacturing. CNC has led to increased productivity because the consistency of the process has lowered manufacturing costs, increased product quality, and led to the development of new techniques. Persons possessing skills in CADD and CNC can find a variety of opportunities in manufacturing industries.

## Computer-Integrated Manufacturing (CIM)

**Computer-integrated manufacturing (CIM)** brings together all the technologies in a management system, coordinating CADD, CAM, CNC, robotics, and material handling from the beginning of the design process through the packaging and shipment of the product. The computer system is used to control and monitor all the elements of the manufacturing system. Figure 3.27 illustrates an example of CAD within a CIM process. The field of CIM incorporates the disciplines of CAD, CAM, robotics, electronics, hydraulics, pneumatics, computer programming, and process control. Computer-integrated manufacturing enables all persons within a company to access and use the same database that designers and engineers would normally use.



**FIGURE 3.27** A representation of CADD data used within a CIM process of automobile assembly and inspection. *Courtesy Autodesk, Inc.*



**FIGURE 3.28** A technical illustration used for marketing applications. *Courtesy O'Neil & Associates, Inc.*

Within CIM, the computer and its software controls most, if not all, portions of manufacturing. A basic CIM system can include transporting the stock material from a holding area to the machining center that performs several machining functions. From there, the part can be moved automatically to another station where additional pieces are attached, then on to an inspection station, and from there to shipping or packaging.

## Additional Applications

In addition design and manufacturing, CADD provides usable data for and supports many other areas of the engineering design process. Most sales and marketing materials, technical publications, and training documents reference some form of CADD data. Often existing drawings and models provide the majority of critical content required for items such as product brochures and installation and service manuals. Chapter 14, *Pictorial Drawings and Technical Illustrations*, provides detailed coverage of **technical illustration**, a common application of CADD in industry. Technical illustration involves the use of a variety of artistic and graphic arts skills and a wide range of media in addition to pictorial drawing techniques. Figure 3.28 shows an example of a technical illustration partly created by directly reusing existing CADD data from the design process.

## THE COMPETITIVE EDGE

In today's highly competitive and tightly timed global market, manufacturers are constantly looking for ways to maintain a competitive edge. Modern technology and engineering practices have increased the need for basic CAD software extensions such as tolerance analysis and data management tools. In addition, many companies have experienced a greater need to put products or sample products into the hands of the customer during development. Customers now often expect to study sample products during design. However, creating sample parts during development can cost thousands of dollars. The solution to this problem is simple and inexpensive.

The last 20 years have produced many innovations in product development resources. Rapid prototyping is one innovation in particular that has produced significant value for Synerject LLC, a manufacturer of marine, motorcycle, and recreational engine components. According to David Cvengros, Supervisor of the Engineering Design Services Department at Synerject North America in Newport News, Virginia, "Synerject purchased its first RP machine in October 2007, and we have not had any regrets since. We have seen an increase in product interest since being able to provide our customers with developmental models that they can handle and mount on their vehicles."

According to Todd Answine, Manager, Business Development and Fuel Components Architecture, Synerject North America, "From the business development perspective, rapid prototyping provides Synerject with a competitive advantage early in the acquisition phase of a project. We can go into a meeting to discuss our initial proposal with a customer, and instead of just talking to slides on a screen, we can put a concept part into the customer's hands. This makes it easier to communicate our ideas and also builds customer's confidence in Synerject's knowledge and abilities."

Three-dimensional RP capability has enabled Synerject's Engineering Design Services Department to develop products at a much more rapid pace than ever before. Though 3-D CAD models are extremely valuable, some design concepts can only be captured in a real 3-D model. RP resource gives Synerject this capability. Designers and drafters at Synerject are sometimes able to build small sections of a product within a half-hour to validate fit and form. This allows the designers and drafters to adjust the design with almost immediate design evaluation or validation. RP reduces design

errors and has dramatically reduced the number of revisions required after production release. Synerject has moved into creating sections of production tooling to validate fit, form, and function before the tooling is machined. This low-cost evaluation process has proven useful in identifying minor concerns that would have cost time and resources to modify after initial manufacture. Simple orientation and form gages for the production line have also been incorporated into the RP machines' support capabilities.

According to Jamie Kimmel, Engineering Manager, Synerject North America, "Our rapid prototype capability has greatly improved the quality and speed of our product development. The ability to work with 'real' parts creates better communication with our customers and between the design and manufacturing functions within our organization. Rapid prototyping has allowed us to optimize our product and tooling designs in the early stages of the project, avoiding multiple design repetition and potential mistakes that can add significant cost and delays to our project timing. Rapid prototyping has become an essential part of our design process."

It is no longer enough for some corporations to only model and create working drawings. In order to be a strong competitor, a corporation must be able to move very quickly with an ability to be proactive and reactive, while at the same time accepting nothing less than zero tolerance for quality defect. RP helps to meet these goals. According to David Cvengros, "The inclusion of the rapid prototype machine within Synerject has proven to be one of the best investment decisions that we have made. It is very difficult to place a return on investment that this machine has produced for Synerject. Since having this machine to support our design process for the past three years, I am not sure how we would manage without it moving forward. Rapid prototyping is the competitive edge."

According to Dave Kilgore, Vice President and General Manager, Synerject Global, "Rapid prototyping has significantly improved our capabilities and performance in our business development and engineering efforts. It makes a significant difference when you can show your customer a low cost and fast lead time prototype during the quotation phases of a new program. It has also made a difference in our early design efforts. The cross-functional teams working on the projects get a much better understanding of the project scope when they can touch and feel a part versus only looking at CAD models."

## VIRTUAL REALITY

**Virtual reality (VR)** refers to a world that appears to be real and with many of the properties of an actual world. As a term, *virtual reality* describes a system that allows one or more people to move about and react in a computer-simulated environment. In this environment, virtual objects are manipulated using various types of devices as though they were real objects. This

simulated world gives a feeling of being immersed in a real world, such as the inside and outside of a product or building; the simulation includes sound and touch.

A **walk-through** can be characterized as a camera in a computer program that creates a first-person view of walking through a building, around a product or building, or through a landscape. A **fly-through** is similar to a walk-through, but the first-person camera view is like a helicopter flying through



the area. Fly-through is generally not used to describe a tour through a building. Walk-through or fly-through is the effect of a computer-generated movie in which the computer images represent the real architecture or the VR presentation in which the computer images turn or move as you turn your head in the desired direction. Realistic renderings, animations, and VR are excellent tools to show the client how the building will look inside and out or how a product will operate. Design ideas can be created and easily changed at this stage.

VR requires special interface devices that transmit the sights, sounds, and sensations of the simulated world. In return, these devices record speech and movement and transmit them back to the simulation software program. Virtual reality technology is a logical step in the design process. A VR system provides the capability of interacting with a model of any size from molecular to astronomical. Surgeons can learn on virtual patients and practice real operations on a virtual body constructed from scanned images of the human patient. Home designers can walk around inside a house, stretching, moving, and copying shapes in order to create a finished product. Buildings can be designed and placed on virtual building sites. Clients can take walk-through tours of a building before it is built and make changes as they walk through. Scientists can conduct experiments on a molecular level by placing themselves inside a model of chemical compounds. Using *telerobotics*, a person can *see* through the eyes of a robot while in a safe virtual environment in order to guide a robot into a hazardous situation.

## Passive VR

**Through-the-window VR**, also referred to as **passive VR**, is a common basic VR application. Passive VR is the manipulation of a 3-D model with input from a mouse, trackball, or 3-D motion control device. This allows more than one person to see and experience the 3-D world. A variation on this is a flat-panel display with handles for movement. The window VR unit in Figure 3.29 is designed to allow natural interaction with the virtual environment. Museum and showroom visitors can walk up, grab the handles, and instantly begin interacting. Observers can follow the action by moving beside the primary user. A variety of handle-mounted buttons imitate keyboard keystrokes, joystick buttons, or 3-D motion control device buttons.

Another type of through-the-window VR consists of a special stereoscopic monitor and sensing devices. The viewer wears lightweight, passive, polarized eyewear. The monitor sends the images directly on the screen to generate 3-D images by users wearing the special glasses. This technology also allows several persons to view the same image on the screen (see Figure 3.30).

## Head Mounted Display (HMD)

To interact visually with the simulated world, you wear a head mounted display (HMD), which directs computer images at each eye (see Figure 3.31). The HMD tracks your head movements, including the direction in which you are looking. Using this movement information, the HMD receives updated images from the computer system, which is continually recalculating the virtual



**FIGURE 3.29** This unit is designed to allow natural interaction with the virtual environment. Museum and showroom visitors can walk up, grab the handles, and instantly begin interacting. Observers can follow the action by moving beside the primary user. *Courtesy Virtual Research Systems, Inc.*



**FIGURE 3.30** This lightweight eyewear, a special monitor, and sensing devices generate alternating images, allowing you to see in 3-D. *Courtesy StereoGraphics Corporation*

world based on your head motions. The computer generates new views at a fast rate, which prevents the view from appearing halting and jerky and from lagging behind your movements. The HMD can also deliver sounds to your earphones. The tracking feature of the HMD also can be used to update the audio signal to simulate surround sound effects. The three most important HMD attributes are **field of view (FOV)**, **resolution**, and **weight**.



**FIGURE 3.31** This head-mounted display incorporates both stereo viewing with two small monitors and stereo sound using the attached earphones; it is the principal component of immersive VR. *Courtesy Virtual Research Systems, Inc.*

### Field of View (FOV)

The human visual field is approximately 200° wide for both eyes, about 150° for each eye, and 90° vertically. The portion of the visual field that is visible to both eyes is called the **binocular overlap** and is about 100°. Greater binocular overlap allows a stronger sense of depth. The necessary vertical field of view depends on the application. For example, driving simulators typically require only a narrow vertical field of view because the out-of-window view in most cars is limited in the vertical direction. In addition, scientific research into motion and balance often requires taller vertical fields of view so that test subjects can see below and above them.

### Resolution

Higher resolution throughout the visual field brings out fine detail in a scene (such as the ability to read text on a car's dashboard), makes images look more realistic, and increases the amount of information that can be displayed. The characteristics of a computer monitor are often specified as a size measure (such as 21 in.) and as input resolution (such as 1920 × 1200 pixels). Input resolution is useful in determining compatibility with a particular image generator, and **pixel density** is at least as important in determining visual quality. A reasonable estimate of the visual sharpness for a person with 20/20 vision is 60 pixels/degree. This means that to match human visual quality, an HMD with a field of view of 40° × 30° (H × V) would need to present 2400 × 1800 pixels.

### Weight

A lightweight and balanced HMD helps users feel comfortable. It also allows greater freedom of movement. Professional HMDs can be as light as 350 g (12 oz) or as heavy as 2 kg (4.5 lbs). A way to assist HMD weight is to install a boom mechanism that suspends the HMD from the top, although this typically restricts movement and makes the system more cumbersome. There is a dramatic range in the weights of offered HMDs.

### Other HMD Selection Factors

Other important characteristics of professional HMDs include brightness, contrast, and minimal **motion blur**. Motion blur is related to the response time of the display, the amount of time a pixel takes to go from black to white and back to black again. Motion blur becomes especially important in rapidly changing images such as an action movie or when there are rapid head movements. The HMD should also display a larger **color gamut**, which means the ability to reproduce a scene more accurately.

### Binocular Omni-Orientation Monitor (BOOM)

The Binocular Omni-Orientation Monitor (BOOM) developed by Fakespace, Inc., is a head-coupled stereoscopic display device (see Figure 3.32). The display is attached to a multilink arm system that is counterbalanced. The person can guide the counterbalanced display while looking into it like binoculars. The system is guided with tracking that is attached to the counterbalanced arms.

### Cave Automatic Virtual Environment (CAVE)

The Cave Automatic Virtual Environment (CAVE) projects stereo images on the walls and floor of a room as shown in Figure 3.33. CAVE was developed at the University of Illinois at Chicago to allow users to wear lightweight stereo glasses and to walk around freely inside the virtual environment. Several persons can participate within the CAVE environment as the tracking system follows the lead viewer's position and movements.

### Haptic Interface

The most challenging physical sensation to simulate in a virtual world is the sense of touch. A **haptic interface** is a device that relays the sense of touch and other physical sensations. In this environment, your hand and finger movements can be tracked, allowing you to reach into the virtual world and handle objects. Haptic interfaces of this type hold great potential for design engineers, allowing various team members to manipulate a product design in a virtual environment in a natural way. Although you can handle an object, it is difficult to generate sensations associated with human touch—for example, the sensations that are felt when a person touches a soft surface, picks up a heavy object, or runs a finger across a bumpy surface. To simulate these sensations, very accurate and fast computer-controlled motors generate force by pushing against the user.

Haptic devices are synchronized with HMD sight and sound, and the motors must be small enough to be worn without interfering with natural movement. A simple haptic device is the desktop stylus shown in Figure 3.34. This device can apply a small force, through a mechanical linkage, to a stylus held in the user's hand. When the stylus encounters a virtual object, the user is provided feedback that simulates the interaction. In addition, if the stylus is dragged across a textured surface, it responds with the proper vibration.

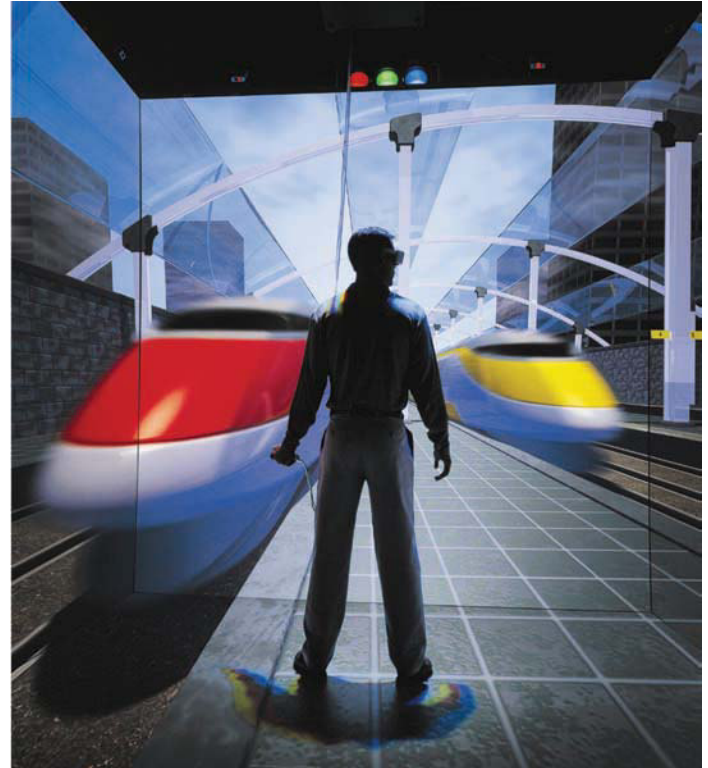


(a)



(b)

**FIGURE 3.32** (a) Binocular Omni-Orientation Monitor (BOOM) allows viewers to view 3-D images without wearing a head-mounted display. (b) This suspended display system is designed for applications such as vehicle simulation and cockpit modeling. The operator can stand or sit, with both hands free to manipulate real or virtual controls and input devices. *Mechdyne Corporation*



**FIGURE 3.33** Cave Automatic Virtual Environment (CAVE) allows viewers to view 3-D images projected on the walls of a room. *Mechdyne Corporation*



Courtesy SensAble Technologies

**FIGURE 3.34** Phantom haptic device provides haptic feedback to the user.

## Web-Enabled Virtual Reality Modeling Language (VRML)

An emerging area in the world of virtual reality is Web-enabled virtual reality modeling language (VRML). VRML is a formatting language that is used to publish virtual 3-D settings called worlds on the World Wide Web (www). Once the developer has placed the world on the Internet, the user can view it using a Web-browser

In the future, engineers may use VR to increase productivity in a variety of areas, including virtual mock-up, assembly, and design reviews. These applications may include the realistic simulation of human factors, such as snap-fits, key component function, and the experiencing of virtual forms. Virtual assemblies may include fit evaluation, maintenance path planning, manufacturability analysis, and assembly training.

**plug-in.** This plug-in contains controls that allow the user to move around in the virtual world as the user would like to experience it. Currently, VRML is a standard authoring language that provides authoring tools for the creation of 3-D worlds with integrated hyperlinks. The current version of VRML is viewed using a basic computer monitor and therefore is not fully immersive. However, the future of VRML should incorporate the use of HMDs and haptic devices, making for more truly immersive environments.

## VR Opportunities

A field of opportunity is available in the creation of virtual worlds. These worlds are detailed 3-D models of a wide variety of subjects. Virtual worlds need to be constructed for many different applications. Persons who can construct realistic 3-D models can be in great demand. The fields of VR geographic information systems (GIS) are combined to create **intelligent** worlds from which data can be obtained while occupying the virtual world. In the future, many cities will have virtual models on their Web sites.

## BASIC CADD TECHNIQUES

The process of preparing a 2-D drawing varies, depending on the CADD software and preferred design techniques. Software centered on 2-D drafting typically requires you to construct geometry such as lines, circles, and arcs, and add dimensions and text. In contrast, to prepare a 2-D drawing when using software or a design process that focuses on building a 3-D model, you typically extract 2-D views from the 3-D model. Two-dimensional drawing concepts and theories are the same regardless of the technique used to produce the drawing. You will learn more about 2-D drawing methods and procedures throughout this textbook.

Designing and drafting effectively with a computer requires a skilled CADD operator. To be a proficient CADD user, you must have detailed knowledge of software tools and processes and know when each tool and process is best suited for a specific task. Learn the format, appearance, and proper use of your software's graphical user interface and customize the GUI according to common tasks and specific applications to increase proficiency. You must also understand and be able to apply design and drafting systems and conventions, plus develop effective methods for managing your work.



**NOTE:** The following information describes general categories of basic CADD functions to provide you with a framework for working efficiently on any project. Specific CADD applications are provided throughout this textbook. Consult your software textbook or HELP files for detailed information on commands, tools, and functions.

## Drawing and Editing

CADD software includes commands for creating and modifying all elements of a drawing for any design requirement. Study the CADD drawing in Figure 3.35 as you explore drawing and

editing with a computer. This drawing of a medical instrument part includes straight lines, circles, arcs, text, dimensions, and numerous symbols created accurately and efficiently using a variety of drawing and editing commands. The CADD applications throughout this textbook provide specific information about drawing and editing with CADD.

## Line Standards and Layers

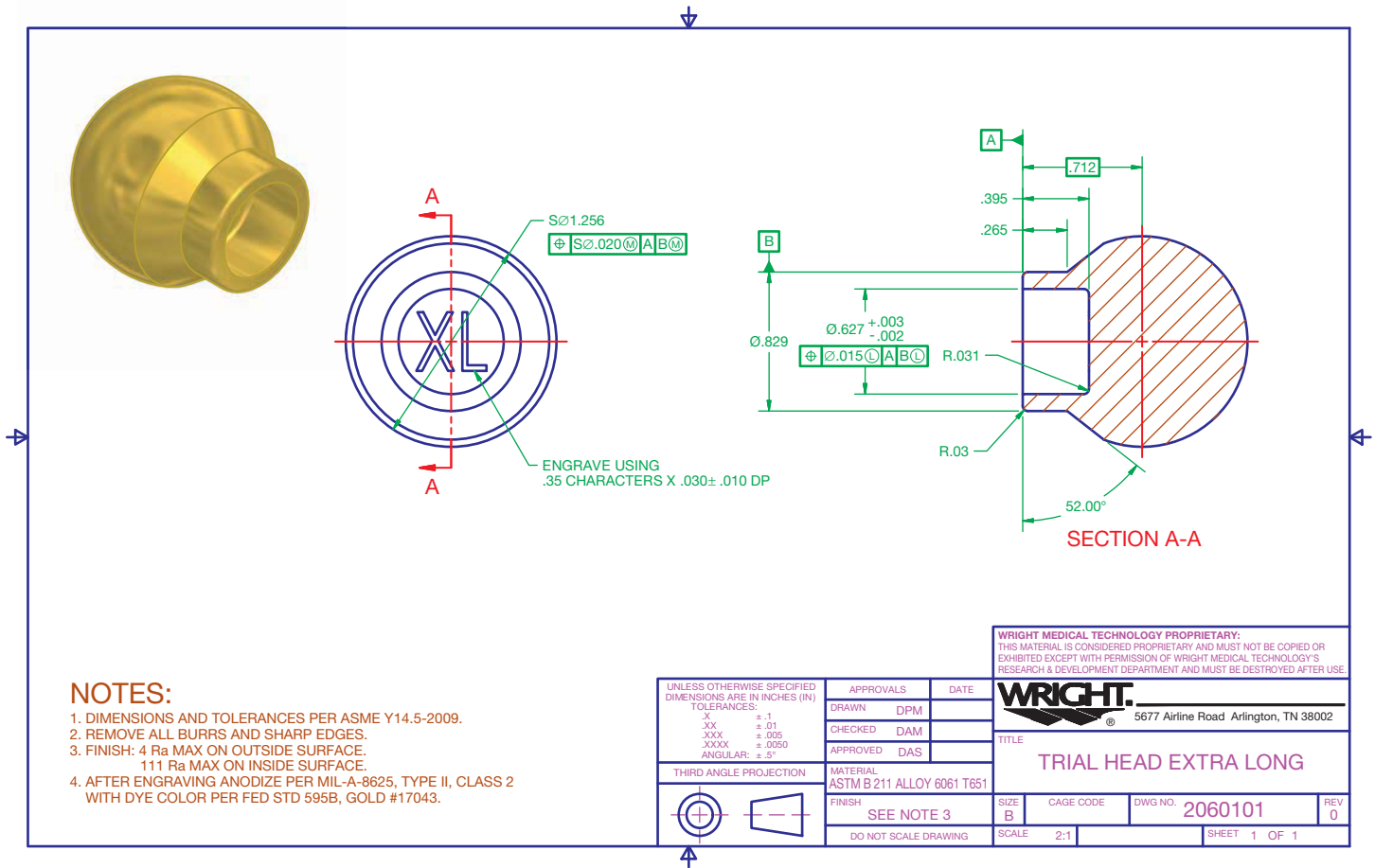
CADD programs often include a **layer** or similar system to organize and assign certain properties to objects. In CADD terminology, layers are elements of the drawing that allow you to separate objects into logical groups for formatting and display purposes. For example, a multiview mechanical drawing can have layers for each unique line type, including object lines, hidden lines, dimensions, and section lines (see Figure 3.36). You can display all layers to show the complete drawing or hide specific layers to focus on certain items. Chapter 6, *Lines and Lettering*, provides detailed information on types of lines. Some CADD systems automatically or semiautomatically set drawing elements on separate layers, and others require that you create your own layering system.

Layers allow you to conform to drawing standards and conventions and help create unique displays, views, and sheets. The following is a list of ways you can use layers to increase productivity and add value to a drawing:

- Assign each layer a unique color, line type, and line weight to correspond to line conventions and to help improve clarity.
- Make changes to layer properties that immediately update all objects drawn on the layer.
- Turn off or freeze selected layers to decrease the amount of information displayed on screen or to speed screen regeneration.
- Plot each layer in a different color, line type, or line weight, or set a layer not to plot.
- Use separate layers to group specific information. For example, draw a floor plan using floor plan layers, an electrical plan using electrical layers, and a plumbing plan using plumbing layers.
- Create several sheets from the same drawing file by controlling layer visibility to separate or combine drawing information. For example, use layers to display a floor plan and electrical plan together to send to an electrical contractor, or display a floor plan and plumbing plan together to send to a plumbing contractor.

## Layers Used in Industry

The drawing typically determines the function of each layer. You can create layers for any type of drawing. Draw each object on a layer specific to the object. In mechanical drafting, you usually assign a specific layer to each different type of line



**FIGURE 3.35** CADD software offers a variety of drawing and editing commands and options that allow you to create drawings for any application accurately and efficiently, such as the drawing of this medical instrument part. Courtesy Wright Medical Technology, Inc.

or object. The following is an example list of common layers and basic properties assigned to each layer for mechanical drafting applications.

Layer Name	Line Type	Line Weight	Color
Object	Solid (continuous)	.02 in. (0.6 mm)	Black
Hidden	Hidden (dashed)	.01 in. (0.3 mm)	Blue
Center	Center	.01 in. (0.3 mm)	Green
Dimension	Solid (continuous)	.01 in. (0.3 mm)	Red
Construction	Solid (continuous)	.01 in. (0.3 mm)	Yellow
Border	Solid (continuous)	.02 in. (0.6 mm)	Black
Phantom	Phantom	.01 in. (0.3 mm)	Magenta
Section	Solid (continuous)	.01 in. (0.3 mm)	Brown

Architectural and civil drawings, for example, can require hundreds of layers, each used to draw a specific item. For example, create full-height floor plan walls on a black A-WALL-FULL layer that uses a .02 in. (0.5 mm) solid (continuous) line

type. Add plumbing fixtures to a floor plan on a blue P-FLOR-FIXT layer that uses a .014 in. (0.35 mm) solid (continuous) line type. Draw roadway centerlines on a site plan or map using a green C-ROAD-CNTR layer that uses a .014 in. (0.35 mm) centerline type.

Layer names are usually set according to specific industry or company standards. However, simple or generic drawings may use a more basic naming system. For example, the name *Continuous-White* indicates a layer assigned a continuous line type and white color. The name *Object-Red* identifies a layer for drawing object lines that is assigned the color red. Layer names that are more complex are appropriate for some applications, and these include items such as drawing number, color code, and layer content. For example, the name *Dwg101-3Dim* refers to drawing DWG101, color 3, for use when adding dimensions. The *CAD Layer Guidelines* from the American Institute of Architects (AIA), associated with the NCS, specifies a layer naming system for architectural and related drawings. The system uses a highly detailed layer naming process.



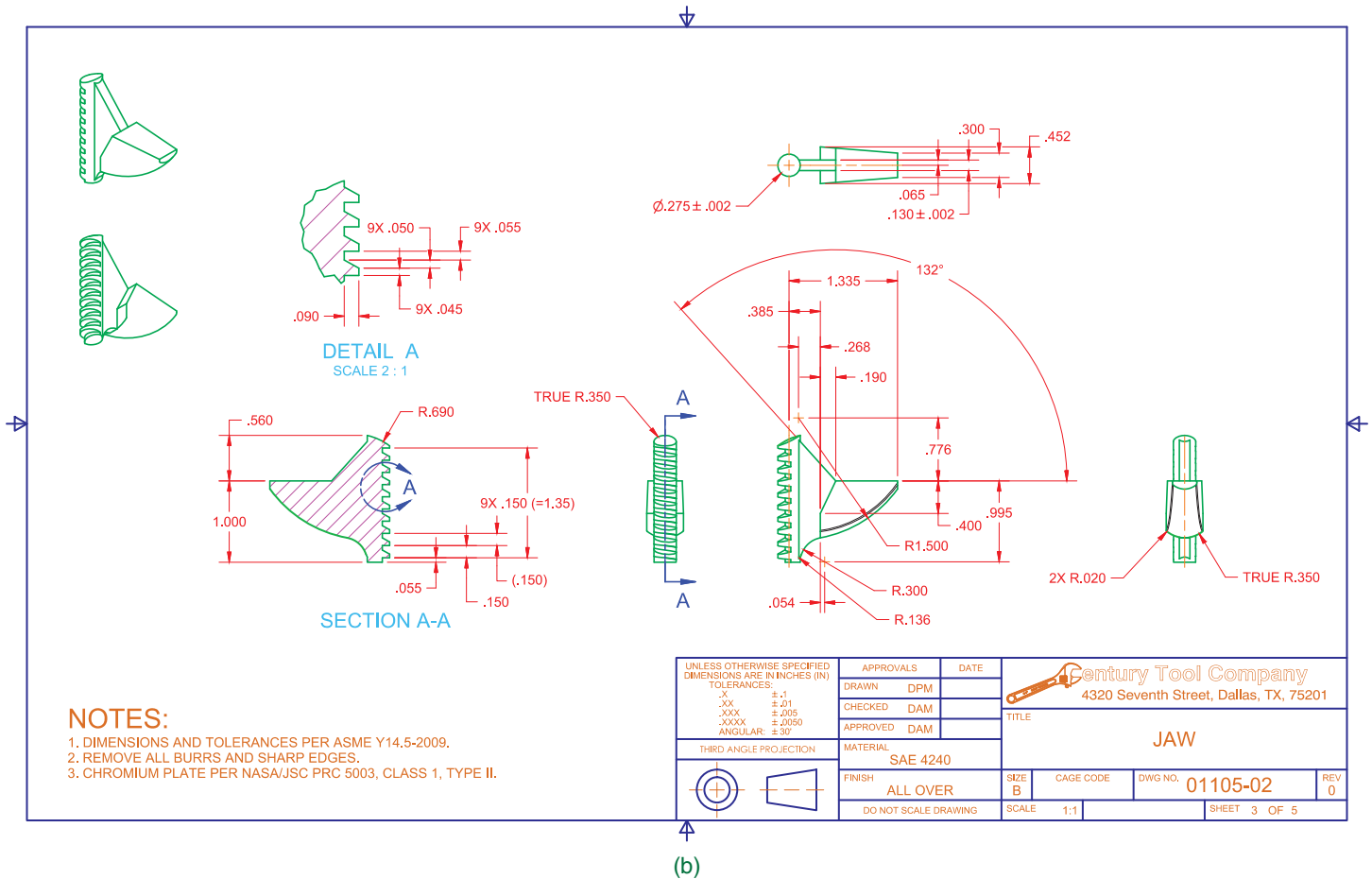


FIGURE 3.36 (Concluded) Courtesy Century Tool Company

**United States National CAD Standard**

For information on the AIA's *CAD Layer Guidelines*, go to the Student CD, select **Supplemental Material, Chapter 3**, and then **United States National CAD Standard**.

### Reusing Content

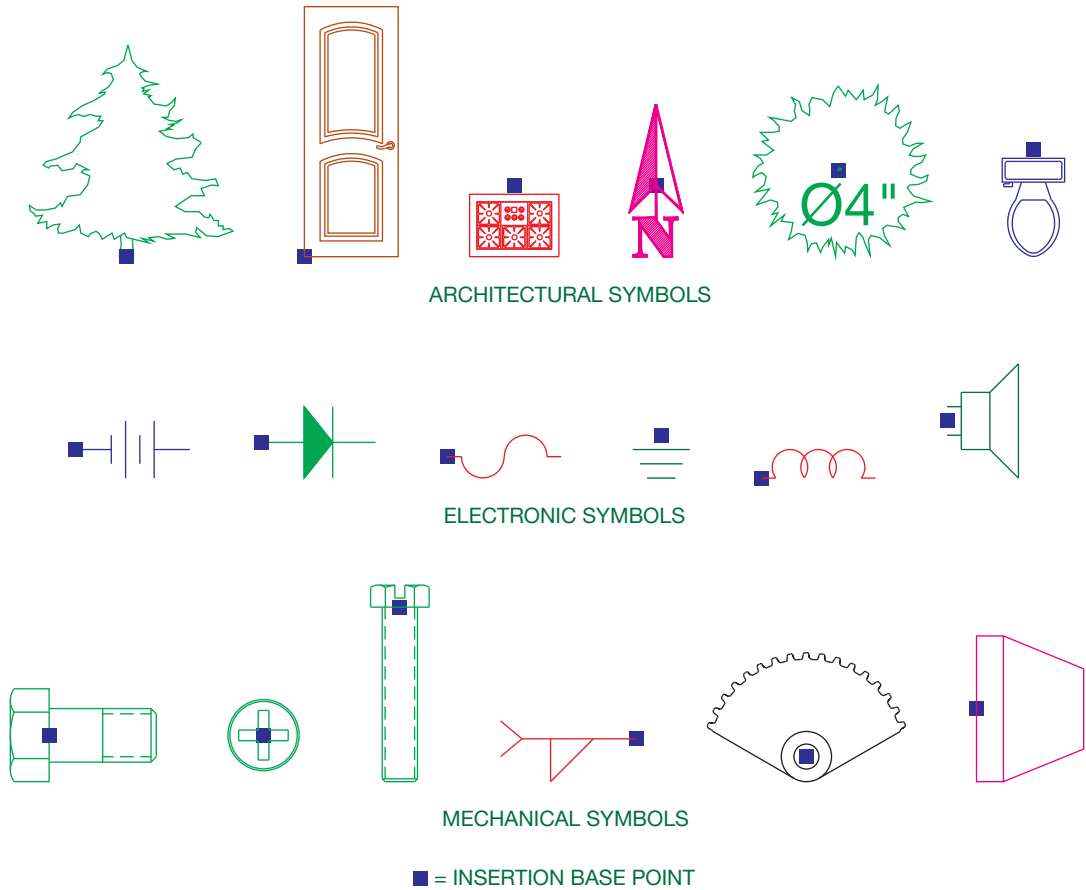
One of the most productive features of CADD is the ability to reuse **drawing content**—that is, all of the objects, settings, and other elements that make up a drawing. Drawing contents such as objects and object properties, text and dimension settings, drafting symbols, sheets, and typical drawing details are often duplicated in many different drawings. The most basic method of reusing content is to apply commands such as MOVE, COPY, and ROTATE; these allow you to modify or reuse existing objects instead of re-creating or developing new objects.

File templates, described later in this chapter, are another way to reuse drawing content. Customized templates provide

an effective way to start each new file using standard settings. Another method to reuse drawing content is to seek out data from existing files. This is a common requirement when developing related drawings for a specific project or working on similar projects. Sharing drawing content is also common when revising drawings and when duplicating standards used by a consultant, vendor, or client. Most CADD programs provide several other options that automate the process of sharing drawing content, including reusing predrawn symbols and entire drawings. Specific CADD applications throughout this textbook provide additional information about reusing content with CADD.

### CADD Symbols

The ability to create and store symbols in a drawing for future use is a major benefit to drawing with CADD. Saved reusable symbols are known by names such as *symbols*, *blocks*, *cells*, and *reference files*, depending on the CADD software. You can insert symbols as often as needed and share symbols between drawings. You also often have the option to scale, rotate, and adjust symbols to meet specific drawing requirements. Using symbols saves time in drawing creation and increases productivity.



© Cengage Learning 2012

**FIGURE 3.37** Examples of common drafting symbols with practical insertion base points for insertion on drawings.

Draw the elements of a symbol as you would any other geometry. A symbol can usually consist of any object or group of objects, including annotation, or it can be an entire drawing. Review each drawing and project to identify items you can use more than once. Screws, punches, subassemblies, plumbing fixtures, and appliances are examples of items to consider converting to reusable symbols. The process of converting objects to symbols varies with each CADD software. The common requirements are to select the objects to define as the symbol, specify an insertion base point that determines where the symbol is positioned during insertion, and save the symbol using a unique descriptive name. Figure 3.37 shows some common drafting symbols. Once you create a symbol, the symbol is ready to insert in the current file or be added to other files as needed. As you define symbols, prepare a **symbols library** in which each symbol is available for reference. A symbol library is a collection of symbols that can be used on any drawing.

### File Referencing

CADD software usually provides additional ways to reuse content, such as a system for referencing existing files. For

example, AutoCAD provides an **external reference**, or **xref**, system to automate and manage file referencing. File-referencing tools provide an effective way to use and relate existing base drawings, complex symbols, images, and details to other drawings. File referencing also helps multiple users share content. Whether you have the option to reference a variety of files depends on the CADD software. For example, AutoCAD allows you to reference a drawing (DWG), design web format (DWF and DWFx), raster image, digital negative (DNG), or portable document format (PDF) file.

Referencing a file is similar to inserting an entire drawing or a portion of a drawing as a symbol. However, unlike a symbol, which usually stores in the file in which you insert the symbol, reference file information does not add to the host drawing. File data appears on-screen for reference only. The result is usable information but with a much smaller host file size than if you inserted a symbol or copied and pasted objects. Another benefit of file referencing is the link between reference and host files. Any changes you make to reference files update in host drawings to display the most recent reference content. This allows you or a design drafting team to work on a multifile project with the assurance that any revisions to reference files display in host drawings.



## Plotting

A drawing created in CADD initially exists as a **soft copy**. A soft copy is the electronic data file of a drawing or model. A **hard copy** is a physical drawing created on paper or some other media by a printer or plotter. Hard copies are often a required element of the engineering or construction process, and they are more useful on the shop floor or at a construction site than soft copies. A design team can check and redline a hard copy without a computer or CADD software. CADD is the standard throughout the world for generating drawings, and electronic data exchange is becoming increasingly popular. However, hard-copy drawings are still a vital tool for communicating a design.

Each CADD system uses a specific method to plot, though the theory used in each is similar. In general, you must specify the following settings in order to plot:

- Printer, plotter, or alternative plotting system to which the drawing is sent, which is called the *plot device*.
- Plot device properties.
- Sheet size and orientation.
- Area to plot.
- Scale.
- Number of copies.
- Software and drawing specific settings.

The drawing scale, described in Chapter 2, *Drafting Equipment, Media, and Reproduction Methods*, is an important consideration when plotting. Some CADD applications such as Autodesk Inventor, Pro/Engineer, NX, and SolidWorks highly automate plotting, especially the process of scaling a drawing for plotting. Other systems such as AutoCAD and MicroStation require you to follow specific procedures to scale a plot correctly. AutoCAD, for example, uses a **model space** and **paper space** system. Model space is the environment in which you create drawings and designs at full scale. Paper space, or **layout**, is the environment in which you prepare the final drawing for plotting to scale. The layout often includes items such as viewports to display content from model space, a border, sheet blocks, general notes, associated lists, sheet annotation, and sheet setup information (see Figure 3.38).

### Scale Factor

**Scale factor** is the reciprocal of the drawing scale, and it is used in the proper scaling of various objects such as text, dimensions, and graphic patterns. Most modern CADD software automates the process of scaling a drawing, allowing you to focus on choosing a scale rather than calculating the scale factor. However, scale factor is a general concept with which you should be familiar, and it remains an important consideration when working with some CADD applications.

When drawing with CADD, always draw objects at their actual size, or full scale, regardless of the size of the objects. For

example, if you draw a small machine part and the length of a line in the drawing is .05 in. (1.27 mm), draw the line .05 in. (1.27 mm) long. If you draw an aircraft with a wingspan of 200' (60,960 mm), draw the wingspan 200'. These examples describe drawing objects that are too small or too large for layout and printing purposes. Scale the objects to fit properly on a sheet, according to a specific drawing scale.

When you scale a drawing, you increase or decrease the displayed size of objects. AutoCAD, for example, uses model space and paper space for this process. Scaling a drawing greatly affects the display of items added to full-scale objects such as annotations, because these items should be the same size on a plotted sheet, regardless of the displayed size, or scale, of the rest of the drawing.

Traditional manual scaling of annotations, graphic patterns, and other objects requires determining the scale factor of the drawing scale and then multiplying the scale factor by the plotted size of the objects. Text is a convenient object to describe application of scale factor. For example, to plot text that is .12 in. (3 mm) high on a mechanical drawing plotted at a scale of 1:4, or quarter-scale, multiply the scale factor by .12 in. (3 mm). The scale factor is the reciprocal of the drawing scale. A 1:4 scale drawing has a scale factor of 4 ( $4 \div 1 = 4$ ). Multiply the scale factor of 4 by the text height of .12 in. (3 mm) to find the .48 in. (12 mm) scaled text height. The proper height of .12 in. (3 mm) text in an environment such as model space at a 1:4 scale is .48 in. (12 mm).

Another example is plotting 1/8 in. high text on a structural drawing plotted at a scale of 1/4" = 1' 0". A 1/4" = 1' 0" scale drawing has a scale factor of 48 ( $1' 0" \div 1/4" = 48$ ). Multiply the scale factor of 48 by the text height of 1/8 in. to find the 6 in. scaled text height. The proper height of 1/8 in. text in an environment such as model space at a 1/4" = 1' 0" scale is 6 in.

### Electronic Plots

**Exporting** is the process of transferring electronic data from a database, such as a drawing file, to a different format used by another program. Exporting a drawing is an effective way to display and share a drawing for some applications. One way to export a drawing is to plot a layout to a different file type. Electronic plotting uses the same general process as hard-copy plotting, but the plot exists electronically instead of on an actual sheet of paper.

A common electronic plotting method is to plot to a portable document format (PDF) file. For example, send a PDF file of a layout to a manufacturer, vendor, contractor, agency, or plotting service. The recipient uses common Adobe software to view the plot electronically and plot the drawing to scale without having CADD software, thus avoiding inconsistencies that sometimes occur when sharing CADD files. Another example is plotting an AutoCAD file to a design web format (DWF or DWFx) file. The recipient of a DWF file uses a viewer such as Autodesk Design Review software to view and mark up the plot.

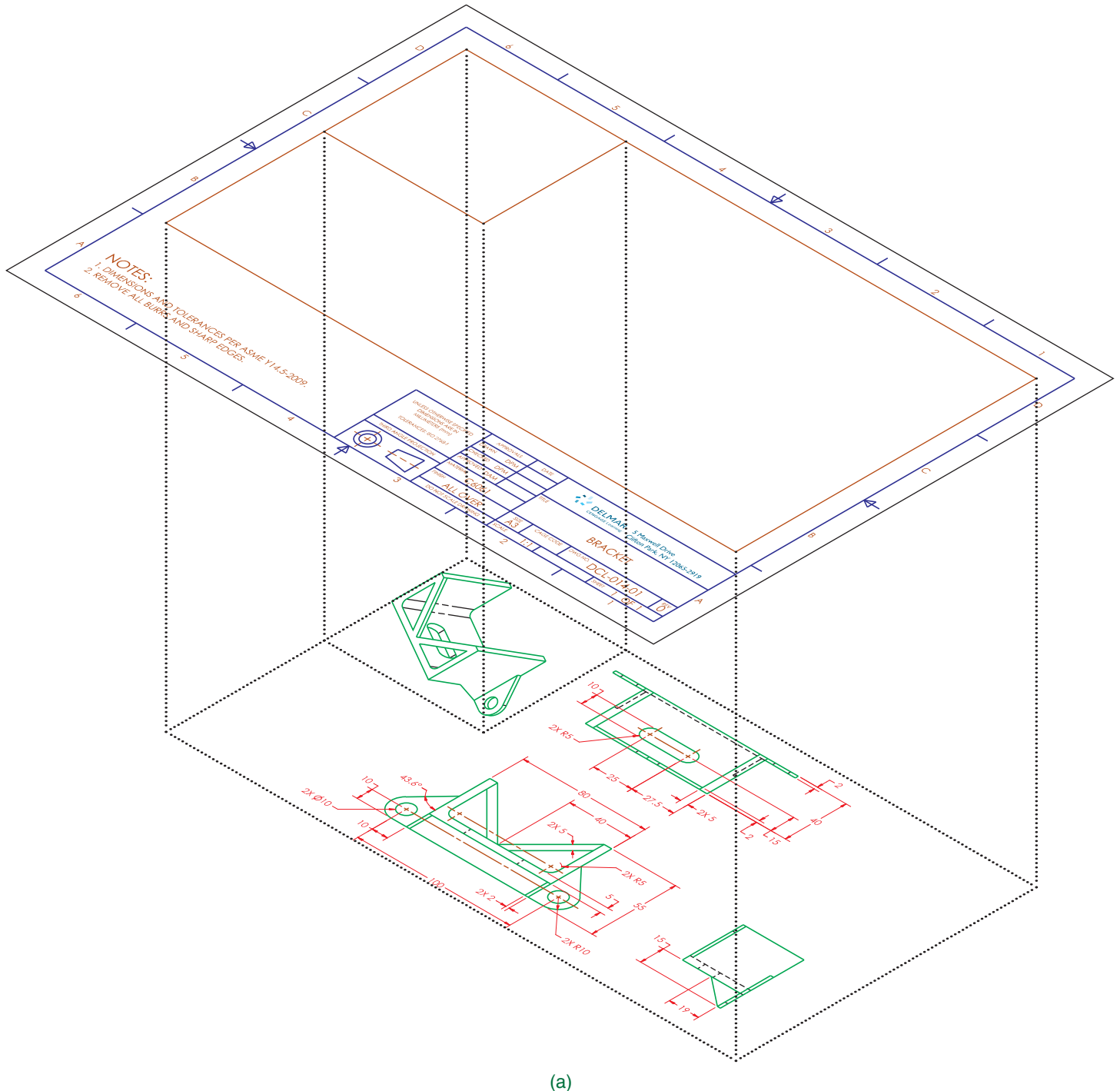
## File Templates

A **file template**, or **template**, is a file that stores standard file settings and objects for use in a new file. All settings and content of a template file are included in a new file.

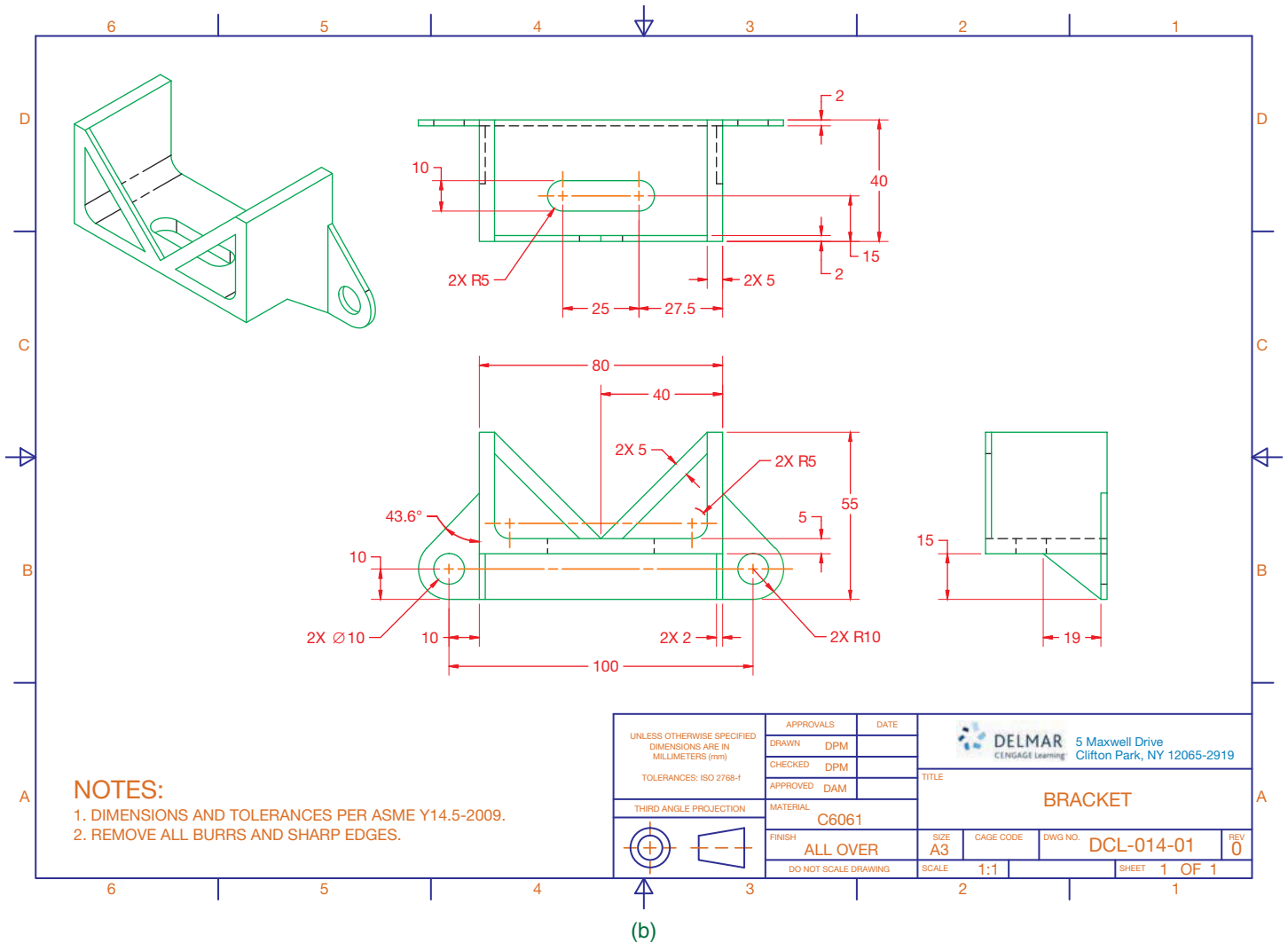
File templates save time and help produce a certain amount of consistency in the drawing and design process. Templates help you create new designs by referencing a base file, such as a

drawing file, that contains many of the standard items required for multiple projects. A drawing-file template is often known as a **drawing template**. File templates function and are used differently depending on the CADD program.

Most CADD software provides tools and options for working with and managing templates. For example, AutoCAD makes use of drawing template (DWT) files that allow you to use the NEW command to begin a new drawing (DWG) file by referencing a



**FIGURE 3.38** (a) The concept of using model space to prepare dimensioned drawing views and paper space to scale the model space drawing and add sheet content for plotting. (b) Model space combined with paper space to create the final drawing with viewport boundaries hidden.



(b)

FIGURE 3.38 (Concluded) © Cengage Learning 2012

saved DWT file. A new drawing file appears, with all the template file settings and contents. Other CADD programs have different but similar applications. This automates the traditional method of opening a file template and then saving a copy of the file template using the name of the new file. You can usually specify or reference any existing appropriate file to use as a template, or you can begin a new drawing using a default template.

Template options and specifications vary, depending on the file type, project, and design and drafting standards. For example, you might use a template for designing parts and another for assemblies, or a template for metric drawings and another for U.S. customary (in.) drawings. A template includes settings for specific applications that are preset each time you begin a new design. Templates may include the following, depending on the CADD format and software, and set according to the design requirement:

- Units settings.
- Drawing and design settings and aids.

- Layers with specific line standards.
- Color, material, and lighting standards.
- Text, dimension, table, and other specialized annotation standards.
- Common symbols.
- Display settings.
- Sheets and sheet items, such as borders, title blocks, and general notes.
- Plot settings.

Create and maintain a variety of file templates with settings for different drawing and design disciplines and project requirements. Store your templates in a common location that is easily accessible, such as the local hard disk or the network server. Keep backup copies of templates in a secure location. As you work, you may discover additional items that should be included in your templates. Update templates as needed and according to modified settings or new standard

practices. When using AutoCAD, for example, use the OPEN command to open a DWT file. Then add content to the file as needed. Once you resave the file, the modified template is ready to use. Remember to replace all old template copies with updated versions.



### Drafting Templates

To access CADD template files with predefined drafting settings, go to the Student CD, select **Drafting Templates**, and then select the appropriate template file. Use the templates to create new designs, as a resource for drawing and model content, or for inspiration when developing your own templates. The ASME-Inch and ASME-Metric drafting templates follow ASME, ISO, and related mechanical drafting standards. Drawing templates include standard sheet sizes and formats and a variety of appropriate drawing settings and content. You can also use a utility such as the AutoCAD DesignCenter to add content from the drawing templates to your own drawings and templates. Consult with your instructor to determine which template drawing and drawing content to use.

## Storing and Managing Files

Store drawings on your computer or a network drive according to school or company practice. Save files immediately after you begin work and then save at least every 10–15 minutes while working to avoid losing work due to software error, hardware malfunction, power failure, or accident. It is better to lose 10 minutes of work rather than the work you have done all day. Most CADD software offers automatic save and file-backup functions, but you should also frequently save your work manually. Back up files to a removable storage device or other system to help ensure information is not permanently lost during a system failure.

Develop an organized structure of file folders. An example of a mechanical drafting project is a main folder titled “ACME.4001” based on the company name ACME, Inc. and project and assembly number 4001. An example of a structural drafting project is a main folder titled “SMITH0110” to identify the first Smith Building project of 2010. Use subfolders as needed to help organize each project.

The name you assign to a file is one of several file properties. File naming is typically based on a specific system associated with the product and approved drawing standards. A file name should be concise and allow you to determine the content of a file. File name characteristics vary greatly, depending on the product, specific drawing requirements, and drawing standard interpretation and options. For example, the name

“MDI-101052-015” given to a drawing of a bracket identifies the file as manufactured by Madsen Designs, Inc. (MDI), the project or assembly number 101052, and bracket part number 015. The U.S. National CAD Standard (NCS) includes a comprehensive file-naming structure for architectural and construction-related drawings. You can adapt the system for other disciplines.

**File management** refers to the methods and processes of creating a management system and then storing, retrieving, and maintaining the files within the guidelines of the computer system. A wide range of file management systems are used in industry, including advanced PLM and PDM software. Become familiar with the system used in your school or company. One of your goals should be to handle your work in the most efficient and productive manner possible. Effective file management procedures can help you reach this goal regardless of the project. Proper file management should include the following:

- Save all working files on a regular basis. Save files to at least two different media, such as the local hard disk and a removable storage device. In addition, establish automatic safeguards for saving your work on a regular basis. Most CADD programs have an automatic save function to save your drawing periodically.
- Create storage media directories and folders for all files.
- Never save data files such as CADD drawings, text documents, and spreadsheets to folders that contain application programs.
- Create separate folders for each project and subfolders for different types of files in the project.
- Store template file originals in a protected location that allows only selected individuals to edit and save these important files.
- Separate drawing files from other types of files such as text documents, spreadsheets, and database files.
- Maintain off-site locations for file storage and archiving for safekeeping.
- Establish a regular schedule for deleting all backup, temporary, and unnecessary files from your storage media.
- Install only licensed software on your computer system. Always report any unlicensed software to your systems manager.
- Never install software without approval from your instructor, supervisor, or systems manager.



### CADD Hardware

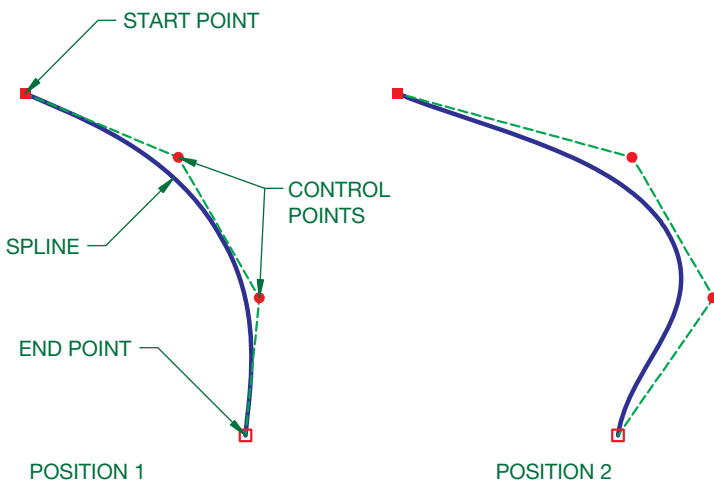
For information about network systems, go to the Student CD, select **Supplemental Material, Chapter 3**, and then **CADD Hardware**.

## SURFACE MODELING TECHNIQUES

Each surface modeling software offers unique methods for creating and working with surface models, depending on the application, such as engineering, illustration, or animation. **Polygonal modeling** is the basic form of surface modeling that produces lower-quality surfaces without precise curvature control. Polygonal modeling creates surfaces that are quick and easy to modify, and this is common for applications such as character design for games. Most CAD systems use **non-uniform rational basis spline (NURBS)** or **non-uniform rational B-spline (NURBS)** mathematics to produce accurate curves and surfaces for surface modeling.

Curves and surfaces are the principal elements of surface models created using NURBS technology. Curves provide the basic form and geometry necessary for constructing surfaces. A NURB curve is a complex mathematical **spline** representation that includes **control points**. A spline is a curve that uses a series of control points and other mathematical principles to define the location and form of the curve. The term *spline* comes from the flexible spline devices used by shipbuilders and drafters to draw smooth shapes. Spline control points typically lie some distance from the curve and are used to define the curve shape and change the curve design (see Figure 3.39). Typically, adding control points to a spline increases the complexity of the curve. Surface modeling uses splines because of their ease and accuracy of construction and evaluation, in addition to their ability to approximate complex shapes through curve design.

A surface model usually includes multiple NURB surfaces known as **patches**. Patches fit together using different levels of mathematical formulas to create what is known as **geometric continuity**. In the simplest terms, geometric continuity is the combining of features into a smooth curve. In actual practice, geometric continuity is a complex mathematical analysis of the shapes used to create the smooth curve. Figure 3.40 shows NURBS used to design a surface. NURB



**FIGURE 3.39** A spline and the control points used to define the curve. Notice how changing control points alters the curve design. © Cengage Learning 2012



NURB CURVE CONSTRUCTION

NURB SURFACE DESIGN

© Cengage Learning 2012

**FIGURE 3.40** Using NURBS mathematics to construct a surface.



**FIGURE 3.41** A sailboat modeled using AeroHydro, Inc., MultiSurf surface modeling software. Courtesy Reinhard Siegel

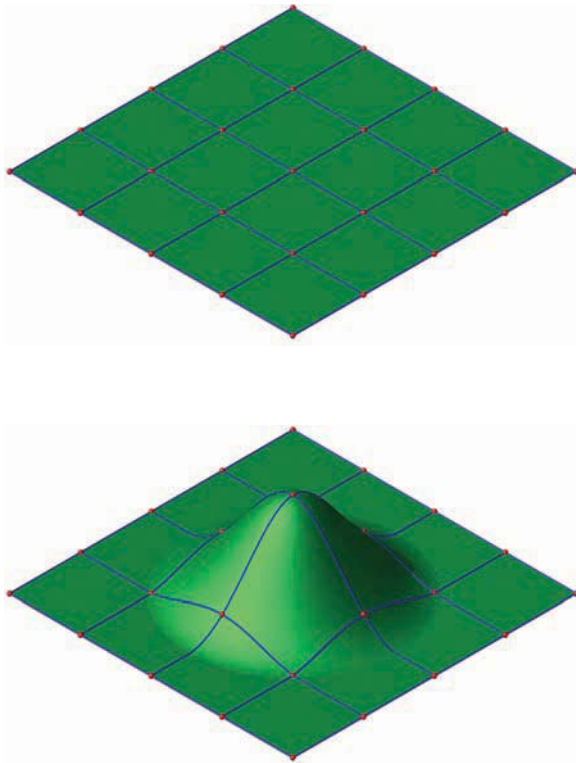
geometry offers the ability to represent any necessary shape from lines to planes to complex free-form surfaces. Examples of applications for freeform shapes include automobile and ship design and ergonomic consumer products. Figure 3.41 shows a surface model of a sailboat with standard and free-form geometric shapes.



**NOTE:** The following information is a brief introduction to surface modeling. Consult your software textbook or HELP files for additional theory and detailed information on commands, tools, and functions.

## Creating Surfaces

Common methods for creating surfaces include direct and procedural modeling and surface editing. You can often apply different surface modeling techniques to achieve the same objective. Usually, a combination of methods is required to develop a complete surface model. Surface modeling, like other



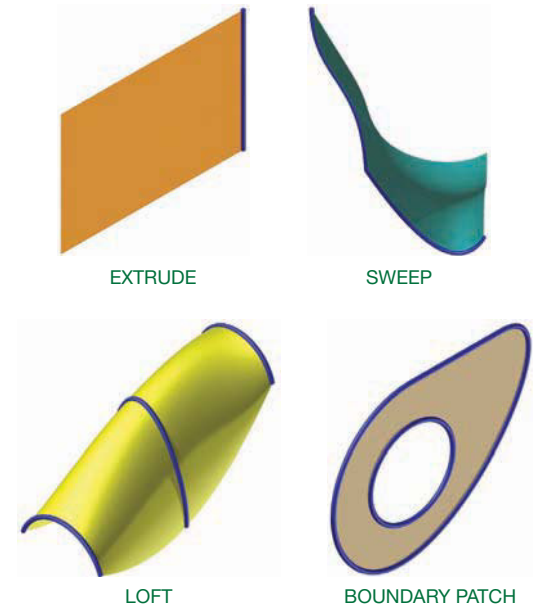
© Cengage Learning 2012

FIGURE 3.42 A basic example of direct surface modeling.

forms of CADD, requires that you have detailed knowledge of software tools and processes and know when each tool and process is best suited for a specific task.

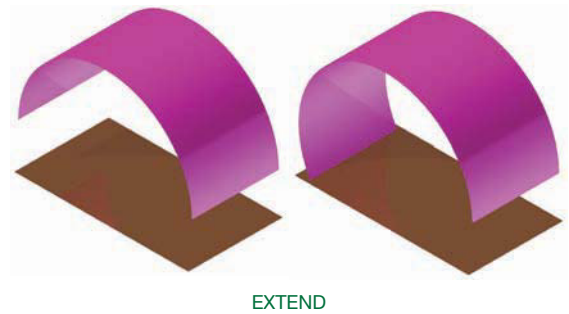
Surface modeling typically involves creating a series of curves that form the spans for defining a surface. Transition surfaces are added as needed to fill gaps within the model. **Direct surface modeling** is a basic method for developing existing surfaces created using multiple curves by adjusting the position of surface control point or poles (see Figure 3.42). Another approach to surface construction is the use of procedural modeling tools to create surfaces from curves. Common options include extruding a curve, sweeping a profile curve along a path curve, lofting through multiple curves, and using curves to define a boundary (see Figure 3.43).

Most surface modeling software provides tools that allow you to construct additional surfaces from initial surface geometry. Examples of these techniques are offsetting, extending, and blending surfaces. Tools are also available for trimming intersecting surfaces. Figure 3.44 shows basic examples of constructing additional surfaces from initial surface shapes. Many other advanced surface modeling tools are also available. Some surface modeling packages provide the ability to manage the structure of surface objects and maintain a modeling history. For high-quality surfaces, analytical tools such as comb curves and zebra analysis are used to check the continuity of curvature so that reflections and highlights can be managed for the best aesthetic quality.

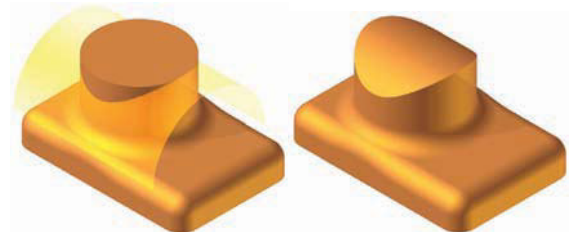


© Cengage Learning 2012

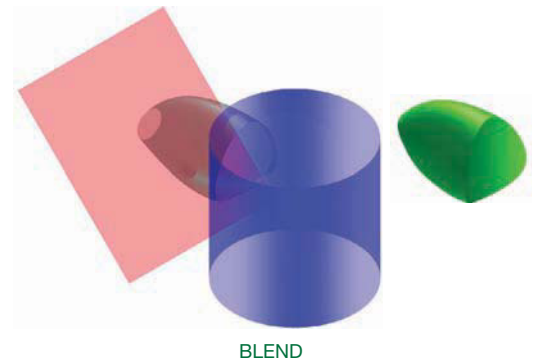
FIGURE 3.43 Using procedural modeling tools to create surfaces from curves.



EXTEND



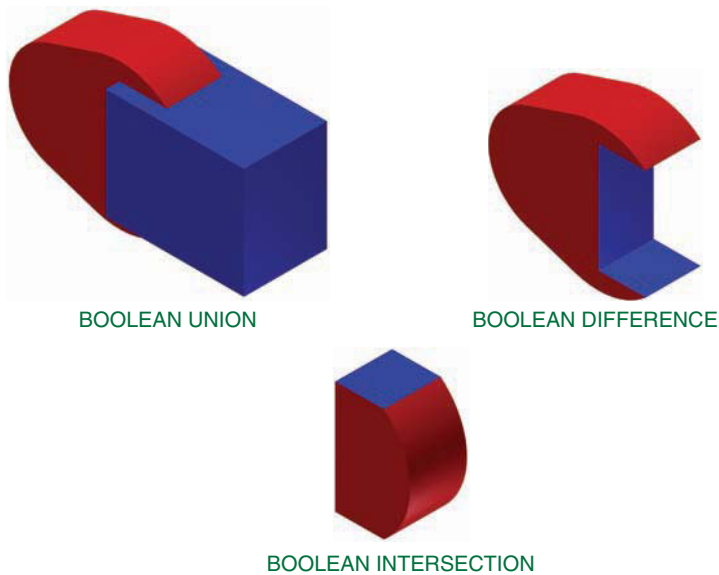
TRIM



BLEND

© Cengage Learning 2012

FIGURE 3.44 Common options for constructing additional surfaces from initial surface shapes.



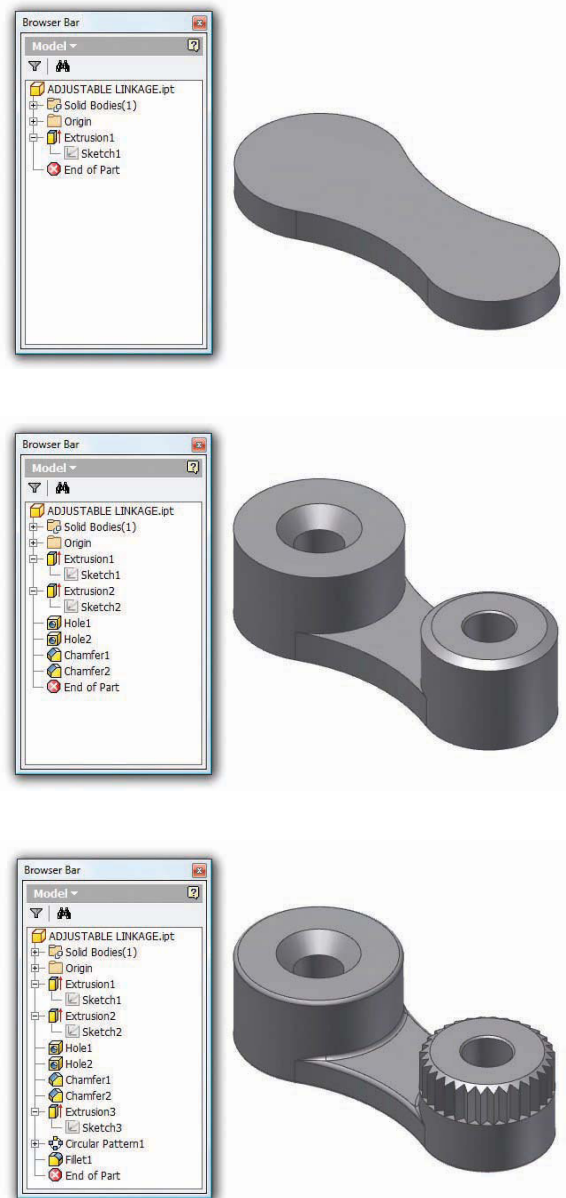
**FIGURE 3.45** A Boolean union joins solids together, a Boolean difference subtracts a solid, and a Boolean intersection retains the intersecting portion of solids. © Cengage Learning 2012

## SOLID MODELING TECHNIQUES

Each solid modeling software offers unique methods for creating and working with solid models. Simple solid modeling programs allow you to build models using **solid primitives**, which are objects such as boxes, cones, spheres, and cylinders that you combine, subtract, and edit to produce a final model. The process of adding and subtracting primitive shapes is known as a **Boolean operation** in geometry (see Figure 3.45). Boolean operations also apply to more complex solid models defined by features and surfaces.

In contrast to modeling with solid primitives, **feature-based solid modeling** programs allow you to construct solid models using more intuitive feature tools. A feature often begins with a 2-D sketch, followed by a sketched feature such as an extrusion or revolution created from the sketch. Additional features add or subtract solid material to generate a final model. Many feature-based solid modeling programs are highly sophisticated and include many advanced tools and functions that significantly automate the design and documentation process. **Parametric** solid models are the most common models created using feature-based solid modeling software. *Parametric* refers to the method of using parameters and constraints to drive object size and location to produce designs with features that adapt to changes made to other features. You will learn more about parametric solid modeling later in this chapter. Some solid modeling programs generate nonparametric solids known as **basic solids** or **dumb solids**.

Feature-based solid modeling programs often maintain a history of the modeling process, which typically appears in a **feature tree** or **history tree** (see Figure 3.46). History-based solid modeling is most often associated with parametric solid



**FIGURE 3.46** History-based solid modeling software saves all information associated with the construction of the model and displays the data in a history tree.

modeling. The software stores and manages all model data including calculations, sketches, features, dimensions, geometric parameters, the sequence in which each piece of the model was created, and all other model history and properties.

Parametric and history-based solid models offer the ability to capture design intent effectively and to maintain design constraints. Parametric modeling is especially useful for designing multiple similar products by changing specific values. However, maintaining detailed design history can add difficulty to the design process, especially when significant changes are required early in the model history and when sharing a model with other members of a design team who do not understand the design history or who use different software.

Dumb solid models and those that do not maintain a design history, often known as **history-free** solid models, can overcome the disadvantages of parametric and history-based solid modeling but are typically not as appropriate for capturing design intent or for designing multiple similar products. Like parametric solids, dumb solids can also add difficulty to the design process. For example, if you cut a hole through a dumb solid model using a difference operation and then realize the hole is no longer needed, you must eliminate the hole using a repair or join operation. Some programs offer a solution to this issue with the ability to recognize features, which allows you to delete and repair the hole easily. **Explicit modeling** is a term that typically refers to direct, history-free modeling. Direct solid modeling describes the process of using more interactive methods, such as pushing or pulling on an edge or face, to create and modify geometry.



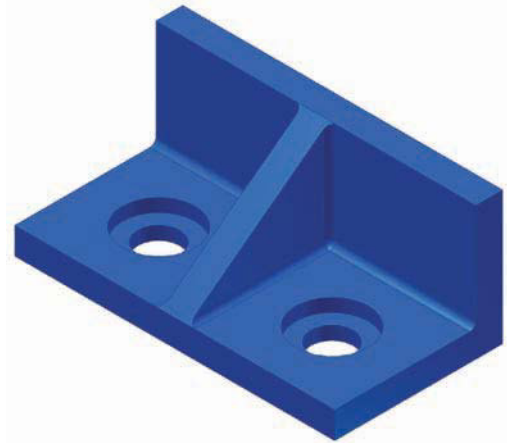
**NOTE:** The following information is a brief introduction to parametric solid modeling. Specific solid modeling CADD applications are provided throughout this textbook. Consult your software textbook or HELP files for additional theory and detailed information on commands, tools, and functions.

## Parametric Solid Modeling

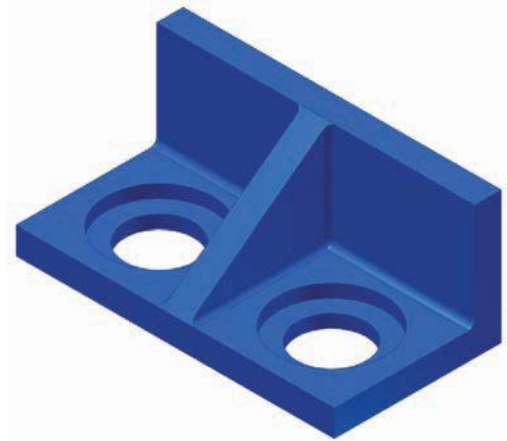
One of the most common 3-D solid modeling techniques is feature-based, parametric solid modeling. Autodesk Inventor, Pro/Engineer, NX, and SolidWorks are examples of feature-based, parametric solid modeling. Many parametric solid modeling programs are surprisingly similar in the way they function. In fact, once you learn the basic process of creating a model using specific software, you can usually transition to different parametric solid modeling software.

Parametric design tools allow you to assign **parameters**, or **constraints**, to objects. Parameters are geometric characteristics and dimensions that control the size, shape, and position of model geometry. A database stores and allows you to manage all parameters. Parametric design is also possible with some 2-D CADD programs. The parametric concept, also known as **intelligence**, provides a way to associate objects and limit design changes. You cannot change a constraint so that it conflicts with other parametric geometry. Parameters aid the design and revision process, place limits on geometry to preserve design intent, maintain relationships between objects, and help form geometric constructions.

Parameters are added by using **geometric constraints** and **dimensional constraints**. Geometric constraints, also known as **relations**, are characteristics applied to restrict the size or location of geometry. Dimensional constraints are measurements that numerically control the size or location of geometry. Well-defined constraints allow you to incorporate and preserve specific design intentions and increase revision efficiency. For example, if the two holes through the bracket shown in Figure 3.47 must always be the same size, then use geometric constraints to make the holes equal and use dimensional constraints



ORIGINAL DESIGN



MODIFIED DESIGN

**FIGURE 3.47** A solid model of a bracket with parametric relationships that control the size and location of holes.

to size one of the holes. The size of both holes changes when you modify the dimensional constraint values.

Parametric modeling systems aid the design process by identifying constraint levels and **modeling failures**. Figure 3.48 shows an example of constraint levels, including **underconstrained**, **fully constrained**, and **overconstrained**. An underconstrained design includes constraints, but they are not enough to size and locate all geometry. A fully constrained design is one in which objects have no freedom of movement. An overconstrained design contains too many constraints, which is not possible within a parametric model. As you progress through the design process, you will often fully or near fully constrain the model to ensure that the design is accurate. However, an error message appears if you attempt to overconstrain the drawing. A modeling failure is the result of constraints, operations, or geometric controls that are impossible to apply to the model.

## Model Work Environments

Parametric solid modeling software often includes several work environments and unique file types for different applications.



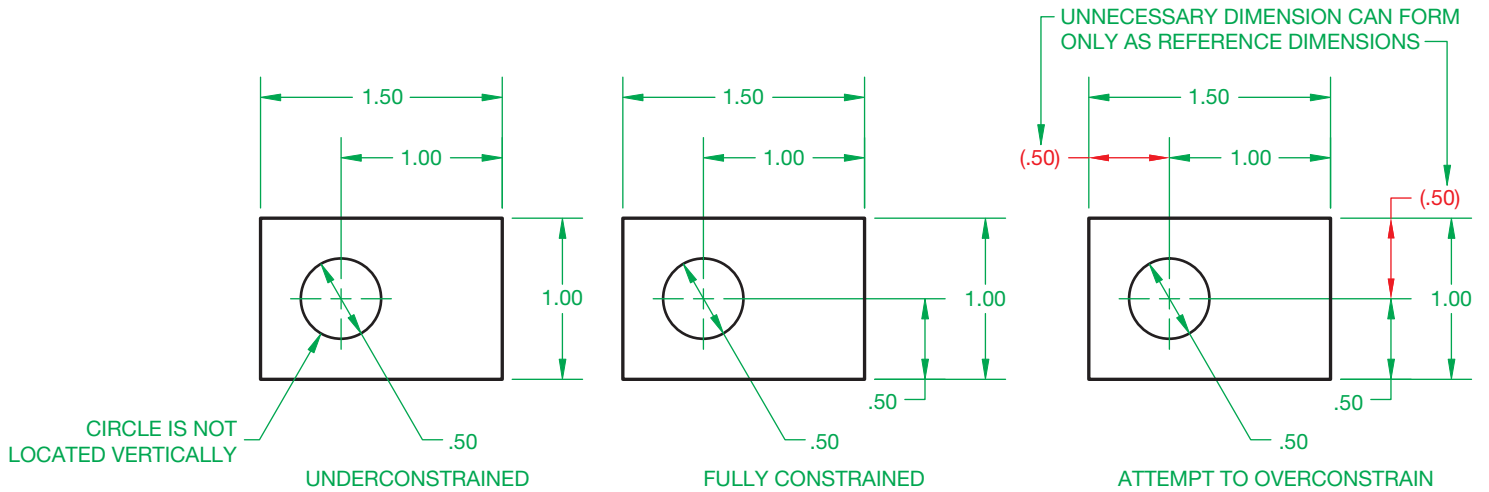


FIGURE 3.48 Levels of parametric constraints. © Cengage Learning 2012

A **part** file allows you to create a part model, such as the engine block shown in Figure 3.49. A part is an item or product or an element of an assembly. Some systems include separate files or work environments for specialized part modeling and related applications, such as sheet metal part design, surface modeling, analysis and simulation, and rendering.

An **assembly** file allows you to reference **component** files to build an assembly model. Components are the parts and **subassemblies** used to create an assembly. A subassembly is an assembly that is added to another assembly. Figure 3.50 shows an engine subassembly that references the engine block part shown in Figure 3.49. The riding lawnmower assembly shown in Figure 3.51 references the engine subassembly and many other components. Some systems include separate files

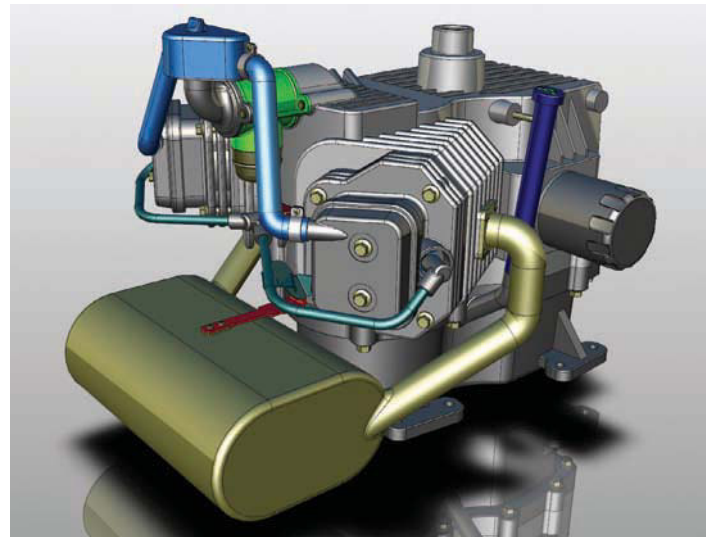


FIGURE 3.50 Engine subassembly model for the riding lawnmower assembly shown in Figure 3.51. Courtesy Kubotek USA

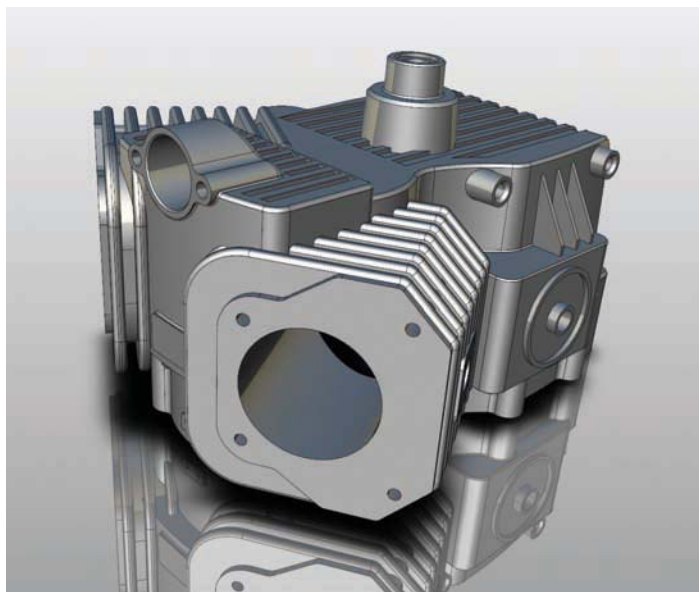


FIGURE 3.49 Engine block part model for the engine subassembly shown in Figure 3.50. Courtesy Kubotek USA



FIGURE 3.51 A lawnmower assembly model that references multiple part and subassembly models. Courtesy Kubotek USA

or work environments for specialized assembly modeling, such as welded product design, exploded assemblies, analysis and simulation, and animation.

**Part Model Elements**

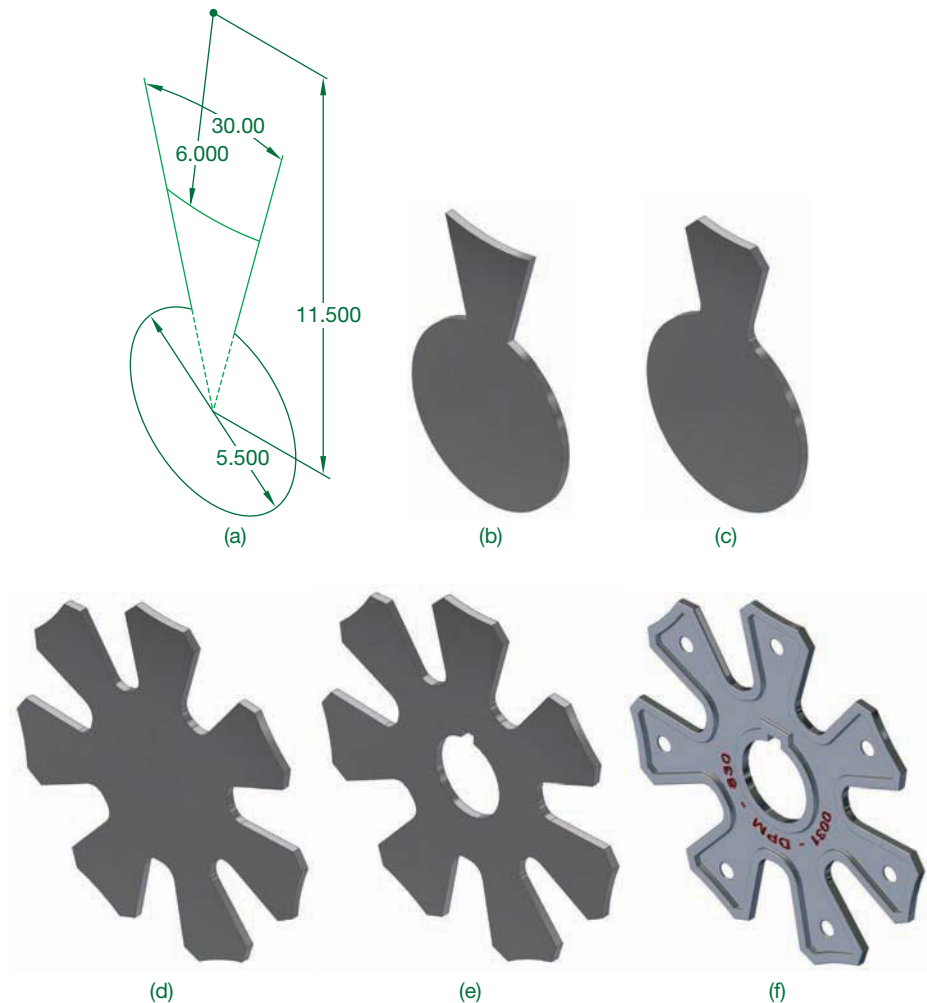
Part models allow you to design parts, build assembly models, and prepare part drawings. A part model begins as a sketch or group of sketches used to construct a feature. Add features as necessary to create the final part model. Primary part model features include sketched, placed, work, catalog, and patterned features. Develop additional model elements, such as surfaces, as needed to build a part model.

Every part model usually contains at least one **sketch** and at least one **sketched feature**. A sketch is 2-D or 3-D geometry that provides the profile or guide for developing sketched features (see Figure 3.52a). A parametric sketch includes geometric constraints that define common geometric constructions such as two perpendicular lines, concentric circles,

equal-sized objects, or a line tangent to a circle. Dimensional constraints specify the size and location of sketch objects. Examples of sketched features built from a sketch include extrusions, revolutions, sweeps, and lofts. Normally, the initial feature on which all other features are built, known as the **base feature**, is a sketched feature, such as the extrusion shown in Figure 3.52b.

Adding **placed features** requires specifying size dimensions and characteristics and selecting a location, such as a point or edge. No sketch is necessary. You typically use a dialog box or other on-screen tool to describe size data. Figure 3.52c shows two of the most common placed features: chamfers and fillets. Placed features are also known as **built-in**, **added**, or **automated features**. Shells, threads, and face drafts are other examples of placed features.

Once you create features, you have the option of developing a **feature pattern**. A feature pattern is an arrangement of copies of existing features, generating occurrences of the features. Figure 3.52d shows an example of a **circular pattern** of sketched



**FIGURE 3.52** (a) A base feature sketch fully defined using geometric and dimensional constraints. (b) Extruding a sketched base feature. (c) Adding chamfers and fillets, common placed features. (d) Applying a circular feature pattern. (e) Adding a catalog feature. (f) The finished model with additional features and rendered.

Courtesy Engineering Drafting & Design, Inc.

and placed features. **Rectangular patterns**, also known as **linear patterns**, and **mirrored features** are other common patterning options. Patterning features often save considerable time while maintaining and forming parametric relationships.

**Reference features**, also known as **work features** or **reference geometry**, are construction points, lines, and surfaces that create reference elements anywhere in space to help position and generate additional features. Often reference features are necessary to build a model when needed geometry is unavailable or to form specific parametric relationships. Common examples of reference features include points, axes, and planes.

A **catalog feature**, also known as a **library feature**, is an existing feature or set of features you create and store in a catalog to use in other models. Catalog features function similar to placed features but are often more complex and represent a specific element such as a certain boss, slot, or stock item. Figure 3.52e shows an example of a placed feature that cuts a hole and keyway through the model. Some software allows you to create **derived components**, which are catalog features that can contain a complete model consisting of several features or even multiple parts. Derived components are often used as a base feature.

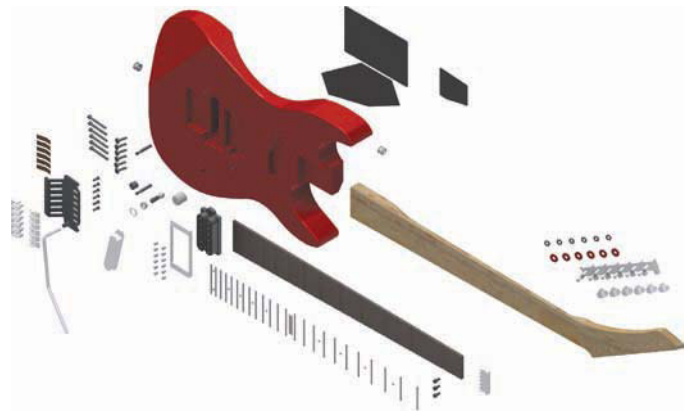
## Assembly Modeling

One option for developing an assembly is to insert existing components into an assembly file and then assemble the components with constraints or mates. This is an example of a process that some designers refer to as **bottom-up design**, and it is appropriate if all or most components already exist. Depending on your approach and the complexity of the assembly, you can insert all components before applying constraints as shown in Figure 3.53. A common alternative is to insert and constrain one or two components at a time.

Another option is to create new components within an assembly file, or **in-place**. This is an example of a process that some designers refer to as **top-down design**. Both assembly techniques are effective, and a combination of methods is common. However, for some applications it is faster, easier, and more productive to develop components in-place. Developing components in an assembly file usually creates an assembly and a separate part or assembly file for each component.

Once you insert or create assembly components, the typical next step is to add **assembly constraints**, also known as **mates**. Assembly constraints establish geometric relationships and positions between components, define the desired movement between components, and identify relationships between the transitioning path of a fixed component and a component moving along the path. There are multiple types of assembly constraints, such as a mate or similar constraint that mates two, or a combination of, component faces, planes, axes, edges, or points. Component geometry and design requirements determine the required constraints.

Constraining an assembly replicates the process of assembling a product. Each constraint removes a certain amount of movement freedom. You can **drive** remaining freedom of



ASSEMBLY COMPONENTS



CONSTRAINED ASSEMBLY

**FIGURE 3.53** Guitar components, including parts and subassemblies, brought together and constrained to form an assembly model.

Courtesy Ethan Collins

movement to examine design concepts. Some constraints automatically occur when you create components in place, which is an advantage to in-place development. However, even components built in-place may require additional constraints or constraint adjustments.

## Editing Parametric Solid Models

The parametric nature of parametric solid modeling software allows you to edit model parameters anytime during the design process. You can manipulate parameters assigned to sketch and feature geometry, parts, and assemblies to explore alternative design options or to adjust a model according to new or different information. The model stores all of the data used to build the model. Often modifying a single parameter is all that is required to revise a model. Other times, a completely different product design is built by editing several existing model parameters. The example in Figure 3.54 shows how changing a few model parameters can significantly alter a product design. In most cases, the tools and options used to edit models are similar or identical to the tools used to create the model originally.

Parametric geometry allows you to make any necessary changes to the design of a model, allowing you to assess design



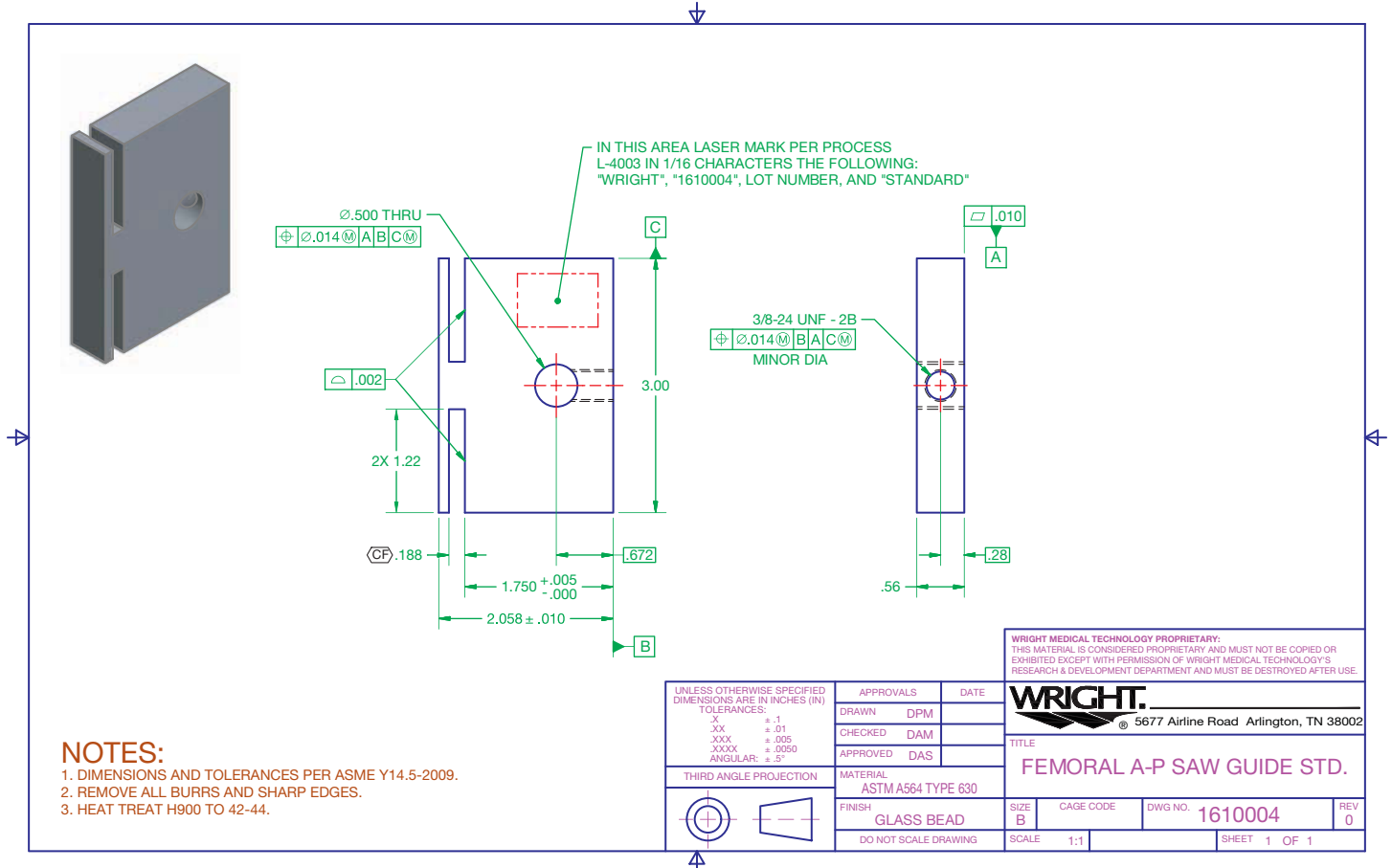
**FIGURE 3.54** Significantly modifying a design by quickly editing a few model parameters.

alternatives almost immediately by changing, adding, or deleting sketches, features, dimensions, and geometric controls. **Parameter-driven assemblies** allow changes made to individual parts to reproduce automatically as changes in the assembly and assembly drawing. **Adaptive parts** in assemblies are effective when you may not know the exact dimensions of a part or you may not fully understand the relationship between assembly components. Adaptive parts modify automatically if another part changes. Parametric geometry also allows you to develop equations that drive your models, allowing a few dimensions to define the entire model or even create a family of related parts.

### Extracting Drawing Content

Some parametric solid modeling CADD systems, such as Autodesk Inventor, Pro/Engineer, NX, and SolidWorks, combine 3-D solid modeling with 2-D drawing capabilities. You can create any type of part, assembly, or weldment drawing from existing models. Figure 3.55 shows an example of a part drawing extracted from a part model. When you edit a model, the corresponding drawing adjusts to reflect the new design. You can also edit a model by modifying parametric model dimensions inside a drawing. Specific CADD applications throughout this textbook provide additional information on extracting drawing content from models.

© Cengage Learning 2012



**FIGURE 3.55** A 2-D part drawing created by referencing a 3-D solid part model. Courtesy Wright Medical Technology, Inc.

## SOLID MODELING PRODUCT DESIGN

Solid modeling has significantly changed the product development process at Water Pik, Inc. ([www.waterpik.com](http://www.waterpik.com)), a manufacturer of oral and sinus health products and shower heads. Water Pik currently uses SolidWorks to help develop products. SolidWorks has allowed the product development team to reduce the product life cycle, including the time it takes a product to get to the market, which has allowed Water Pik to remain competitive in today's highly competitive marketplace.

The number and diversity of products Water Pik has introduced has changed significantly since the company began using solid modeling software 20 years ago. Many more new products are now introduced annually than in the past. Furthermore, new products are being developed using a smaller number of employees than in previous years. Simply stated, a smaller number of people have been able to produce a significantly larger number of products. The advent of CAD solid modeling and in-house rapid prototyping (RP) have made these gains in product development possible.

Solid models provide Water Pik an important tool for improving communications, and they are used to demonstrate future products. Before solid models, industrial engineers relied on basic multiview drawings or hand-made models. Multiview 2-D drawings are difficult for the untrained person to read and interpret, so a communication gap existed between those who had difficulty

reading the drawings such as marketing and salespeople and those who could read the 2-D drawings such as engineering and manufacturing personnel. Solid models have given marketing, sales, and engineering a way to visualize the design before creating physical models. This improved communication has shortened the time needed to make a product and has improved the products' designs.

Maybe even more significant is the impact that solid modeling has had on the appearance of the products at Water Pik. According to Tim Hanson, model shop supervisor, "Solid modeling has significantly changed the complexity of our products. Before we had to design things that were easy to machine. This meant products with straight lines or minimal curves. Today our products do not have a straight line on them." These changes are seen by comparing Water Pik designs from before and after the introduction of solid modeling. The oral irrigator shown in Figure 3.56 was produced in 1987, before solid modeling.

The modern oral irrigators shown in Figure 3.57 were produced using solid modeling. These products have very few simple forms and are comprised of a number of complex surfaces. Another example is the shower head



Courtesy Waterpik Technologies, Inc.

**FIGURE 3.56** Oral irrigator designs before the introduction of 3-D solid modeling.



Courtesy Waterpik Technologies, Inc.

**FIGURE 3.57** Oral irrigator designs created using 3-D solid modeling.

(Continued)

in Figure 3.58, which has an extremely complex form that incorporates a variety of shapes and complex curves. These complex shapes and forms were not possible before solid modeling.

All of these advances in speed, communication, and product design occurred at Water Pik, Inc., because of solid modeling. “Without the solid modeling tool, we would not be able to produce the number of high-quality products that we produce today,” according to Tim Hanson.



Courtesy Waterpik Technologies, Inc.

**FIGURE 3.58** A showerhead design with complex shapes.

## CADD STANDARDS

Most industries, schools, and companies establish CADD standards that specify design and drafting requirements, appearance, and techniques, operating procedures, and record-keeping methods. CADD standards apply to most settings and procedures, including:

- File storage, naming, and backup.
- File templates.
- Units of measurement.
- Layout characteristics.
- Borders and title blocks.
- Symbols.
- Layers, and text, table, and dimension styles.
- Plot styles and plotting.

Company or school CADD standards should follow appropriate national industry standards whenever possible. Chapter 1, *Introduction to Engineering Drawing and Design*, introduces ASME, ISO, AWS, CADD skills standards and NCS drafting standards. CADD software offers the flexibility to adhere to these and other standards. Most drafting standards are universal to any method of design and drafting, including CADD. Some standards such as ASME Y14.41, *Digital Product Definition Data Practices*, CADD skills standards, and NCS focus specifically on standards for CADD applications.

### ASME Y14.41

ASME publication Y14.41, *Digital Product Definition Data Practices*, establishes requirements for the creation and revision of **digital product definition datasets**. Digital product definition datasets are computer files that completely define a product.

The physical and functional requirements of the product are defined in the computer files by graphical or textual presentations or a combination of both. The dataset includes all information required to define the product fully. Information included in the dataset can be a 3-D CAD model, its annotations, and any other supporting documentation believed necessary. The standard supports two methods of defining the product: model only and model and drawing. Existing ASME standards should be used for drawing creation. However, ASME Y14.41 defines exceptions to existing standards and additional requirements for use on datasets and digital drawings.

If a company decides to define the product using only a CAD model, the standard provides guidance for the application of GD&T, size dimensions, and tolerances directly to the model. A company might also decide to use a combination of a CAD model and a 2-D drawing to define the product completely. In this case, the standard provides requirements for the relationship between the model and the drawing. For example, the information on the drawing and in the model shall match. The drawing shall reference all models defined by the drawing. The drawing border and sheet block information is created per ASME Y14.1 or ASME Y14.1M. If the drawing does not contain complete product definition and the model must be queried for complete definition, then it must be noted on the drawing.

### CADD Skill Standards

The U.S. Department of Labor ([www.dol.gov](http://www.dol.gov)) published Occupational Skill Standards Projects in 1996. The CADD skill standards, developed in cooperation with the National Coalition for Advanced Manufacturing (NACFAM) ([www.nacfam.org](http://www.nacfam.org)), summarizes CADD occupation skills generic to all CADD disciplines, software, and entry levels.



## CADD Skill Standards

For more information on the national CADD skill standards project, go to the Student CD, select **Supplemental Material, Chapter 3**, and then **CADD Skill Standards**.

## United States National CAD Standard

A group of agencies, including the CADD/GIS Technology Center (CGTC), the American Institute of Architects (AIA), the Construction Specifications Institute (CSI), the U.S. Coast Guard, the Sheet Metal and Air Conditioning Contractors National Association (SMACNA), and the National Institute of Building Sciences (NIBS), developed the United States National CAD Standard (NCS) in 1997. The NCS primarily applies to architectural and construction-related disciplines and includes the following three documents:

- The American Institute of Architects (AIA) CAD Layer Guidelines.
- The Construction Specifications Institute (CSI) Uniform Drawing System, Modules 1–8.
- The CSI Plotting Guidelines.

For more information or to order the NCS go to the United States National CAD Standard Web site at [www.buildingsmartalliance.org/ncs/](http://www.buildingsmartalliance.org/ncs/).



## United States National CAD Standard

For a comprehensive introduction to the NCS, go to the Student CD, select **Supplemental Material, Chapter 3**, and then **United States National CAD Standard**.

## PRODUCTIVITY WITH CADD

CADD software continues to improve in a variety of ways. CADD programs are easier to use than ever before and contain multiple tools and options, allowing you to produce better-quality and more-accurate drawings in less time. For many duties, CADD multiplies productivity several times, especially for multiple and time-consuming tasks. A great advantage of CADD is that it increases the time available to designers and drafters for creativity by reducing the time they spend on the actual preparation of drawings.

As CADD applications improve, the traditional requirements of a drafter often become less important, while the ability to use new CADD software and application specific tools increases. Productivity gains realized by the use of CADD tools are directly related to the proper use of those tools. In the constantly changing CADD world, you must be prepared to learn new drafting tools and techniques and be open to attending classes, seminars, and workshops on a regular basis.

## Design Planning

Some of the most important and productive time you can spend working on any project or drawing is the time you use to plan. Always plan your work carefully before you begin to use the tools required to create the drawing. A design plan involves thinking about the entire process or project in which you are involved, and it determines how you approach a project. A design plan focuses on the content you want to present, the objects and symbols you intend to create, and the appropriate use of standards. You may want processes to happen immediately or to be automatic, but if you hurry and do little or no planning, then you may become frustrated and waste time while designing and drafting. Take as much time as needed to develop design and project goals so that you can proceed with confidence.

During your early stages of CADD training, consider creating a planning sheet, especially for your first few assignments. A planning sheet should document all aspects of a design and the drawing session. A sketch of the design is also a valuable element of the planning process. A design plan and sketch helps you establish:

- The drawing drafting layout: area, number of views, and required free space.
- Drafting settings: units, drawing aids, layers, and styles.
- How and when to perform specific tasks.
- What objects and symbols to create.
- The best use of CADD and equipment.
- An even workload.

## Ergonomics

**Ergonomics** is the science of adapting the work environment to suit the needs of the worker. There is concern about the effects of the CADD working environment on the individual worker. Some studies have found that people should not work at a computer workstation for longer than about four hours without a break. Physical problems, ranging from injury to eyestrain, can develop when someone is working at a poorly designed CADD workstation. The most common injuries are repetitive motion disorders, also known as **repetitive strain injury (RSI)**, **repetitive movement injury (RMI)**, **cumulative trauma disorder (CTD)**, and **occupational overuse syndrome (OOS)**. Carpal tunnel syndrome is a common repetitive motion

disorder. Most computer-related injuries result from the sedentary nature of working at a computer and the fast, repetitive hand and finger motions typical while using keyboards and pointing devices. Proper workstation ergonomics, good posture, and frequent exercise helps to prevent most computer-related injuries.

### Ergonomic Workstations

Figure 3.59 shows an ergonomically designed workstation. In general, a workstation should be designed so you sit with your feet flat on the floor, your calves perpendicular to the floor and your thighs parallel to the floor. Your back should be straight, your forearms should be parallel to the floor, and your wrists should be straight. For some people, the keyboard should be either adjustable or separate from the computer to provide more flexibility. The keyboard should be positioned, and arm or wrist supports can be used, to reduce elbow and wrist tension. In addition, when the keys are depressed, a slight sound should be heard to ensure the key has made contact. Ergonomically designed keyboards are available.

The monitor should be 18"–28", or approximately one arm's length, away from your head. The screen should be adjusted to 15°–30° below your horizontal line of sight. Eyestrain and headache can be a problem with extended use. If the position of the monitor is adjustable, you can tilt or turn the screen to reduce glare from overhead or adjacent lighting. Some users have found that a small amount of background light is helpful. Monitor manufacturers offer large, flat, nonglare screens that help reduce eyestrain. Some CADD users have suggested

changing screen background and text colors weekly to give variety and reduce eyestrain.

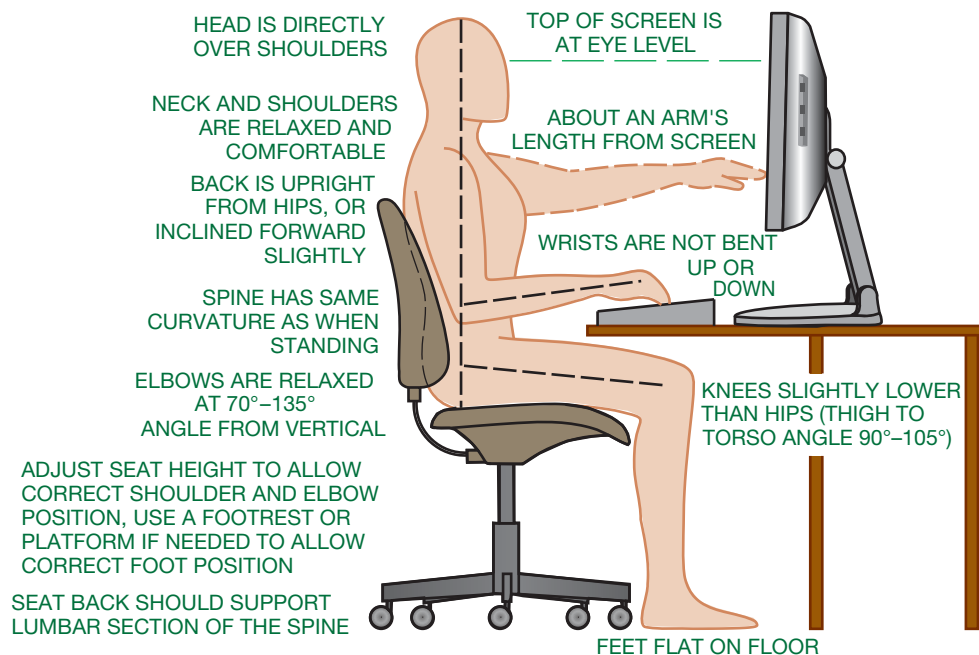
The chair should be designed for easy adjustments to give you optimum comfort. It should be comfortably padded. Your back should be straight or up to 10° back, your feet should be flat on the floor, and your elbow-to-hand movement should be horizontal when you are using the keyboard, mouse, or digitizer. The mouse or digitizer puck should be close to the monitor so movement is not strained and equipment use is flexible. You should not have to move a great deal to look directly over the cursor to activate commands.

### Positive Work Habits

In addition to an ergonomically designed workstation, your own personal work habits can contribute to a healthy environment. Try to concentrate on good posture until it becomes second nature. Keeping your feet flat on the floor helps improve posture. Try to keep your stress level low, because increased stress can contribute to tension, which can aggravate physical problems. Take breaks periodically to help reduce muscle fatigue and tension. You should consult with your doctor for further advice and recommendations.

### Exercise

If you feel pain and discomfort that can be associated with computer use, then some stretching exercises can help. Figure 3.60 shows exercises that can help reduce workstation-related problems. Some people have also had success with yoga, biofeedback,



© Cengage Learning 2012

**FIGURE 3.59** An ergonomically designed workstation.



SITTING AT A COMPUTER WORKSTATION FOR SEVERAL HOURS IN A DAY CAN PRODUCE A GREAT DEAL OF MUSCLE TENSION AND PHYSICAL DISCOMFORT. YOU SHOULD DO THESE STRETCHES THROUGHOUT THE DAY, WHENEVER YOU ARE FEELING TENSION (MENTAL OR PHYSICAL).

AS YOU STRETCH, YOU SHOULD BREATHE EASILY—INHALE THROUGH YOUR NOSE, EXHALE THROUGH YOUR MOUTH. DO NOT FORCE ANY STRETCH, DO NOT BOUNCE, AND STOP IF THE STRETCH BECOMES PAINFUL. THE MOST BENEFIT IS REALIZED IF YOU RELAX, STRETCH SLOWLY, AND FEEL THE STRETCH. THE STRETCHES SHOWN HERE TAKE ABOUT 2½ MINUTES TO COMPLETE.

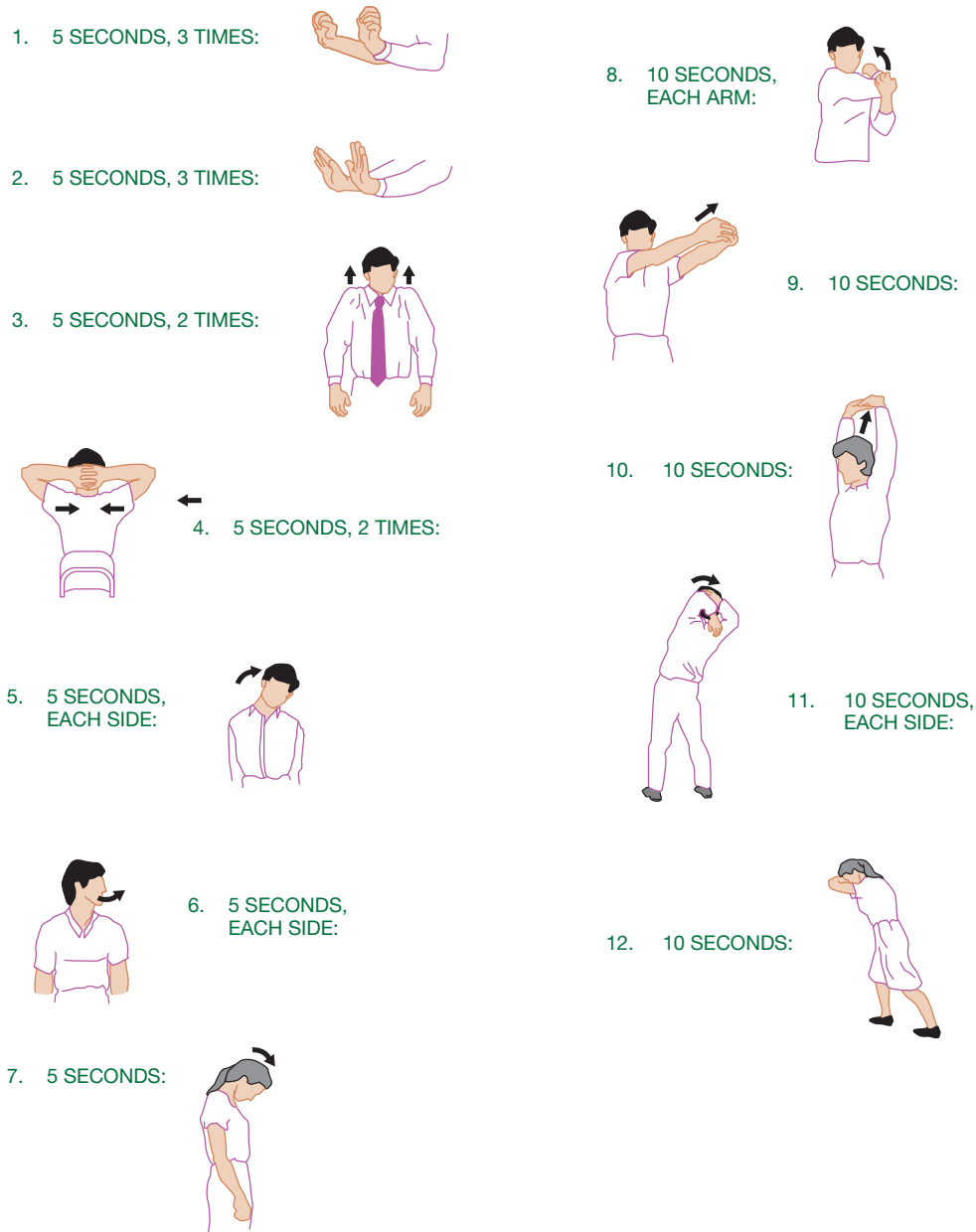


FIGURE 3.60 Stretches that can be used at a computer workstation to help avoid repetitive injury.

© Cengage Learning 2012

and massage. Consult with your doctor for advice and recommendations before starting an exercise program.

**Other Factors**

A plotter makes some noise and is best located in a separate room next to the workstation. Some companies put plotters in

a central room, with small office workstations around them. Others prefer to have plotters near the individual workstations, which can be surrounded by acoustical partition walls or partial walls. Air-conditioning and ventilation systems should be designed to accommodate the computers and equipment. Carpets should be antistatic. Noise should be kept to a minimum.

## GREEN TECHNOLOGY APPLICATION

### SUSTAINABLE DESIGN

**Sustainable design** is the concept of developing products, structures, and services that are environmentally and socially responsible but economically practical. Sustainable design is a broad topic also known by terms such as **green design**, **environmental design**, and **environmentally sustainable design**. **Sustainability** refers to something that can last or is able to be maintained for long periods without damaging the environment or depleting a resource. An environmentally responsible design causes minimal harm to, or even benefits, the environment. A socially responsible design benefits everyone involved in the life cycle of the design, including production, use, and reuse or disposal. An economically practical design is viable in the marketplace.

Sustainable design is often identified with easily recognizable green technology applications, such as clean energy wind and solar power generators, fuel-efficient automobiles, energy-efficient appliances, and recyclable or biodegradable materials. However, any product design, including these well-known green or clean technologies, can use sustainable design and manufacturing practices. The most thorough method of conducting complete sustainability analysis is by using **Life Cycle Assessment (LCA)** tools, such as the PE INTERNATIONAL software GaBi ([www.gabi-software.com](http://www.gabi-software.com)) and the PPE Consultants software SimaPro ([www.pre.nl](http://www.pre.nl)). LCA software helps recognize and measure sustainable design opportunities throughout the life cycle of a product, from raw materials extraction to use and disposal or recycling. This technology highlights the greatest sustainable impacts and can help prioritize where to focus design effort. A manufacturer has several opportunities at the design phase of the product life cycle to reduce environmental impact, increase or maintain social responsibility, and remain economically productive. Often small design changes can have a significant effect on the sustainability of a product.

Material selection is a critical element of sustainable design. Sustainable materials are those that require less energy, resources, and effect on the environment to process and handle; are recyclable or renewable; and are less hazardous and toxic. Steel, aluminum, glass, and some plastics are recyclable. Wood and some plastics are renewable. Often a company can manufacture a product using a recyclable material that is equivalent or superior in performance and cost to a comparable nonrecyclable material. The choice of material can also affect several other factors. A lighter-weight material requires less energy to handle and transport, which can save money. A higher-performance material may accomplish the same task using less material. Chapter 4, *Manufacturing Materials and Processes*, provides additional information on manufacturing material characteristics and selection.

Using the least material possible to meet design requirements is another important element of sustainable design.

A common example is reducing material in vehicle design to decrease weight, which results in better operating economy. Another example is a product such as a bicycle, for which the major environmental impact comes from the raw materials used to manufacture the product and which has very little environmental impact to operate. A primary objective when minimizing material is to design, or **optimize**, a product using efficient geometry, simple features and components, and the least mass possible while maintaining an acceptable working strength and operation. The case study later in this Green Technology Application follows a manufacturer of products for the solar power industry as it optimizes the design of a component to reduce weight and improve function.

Another common example of optimizing material usage is incorporating upgradable components so that when new technology is available, the entire product does not have to be discarded. Standardized parts, batteries, power adaptors, chassis, and similar components can be used in multiple generations of products as other elements of the product evolve. Optimized product design also uses features that accomplish several tasks, such as aesthetic considerations that add structural support. Another option is using the same standardized battery or adaptor for power, which can help improve interoperability and reduce obsolescence.

There are many other examples of sustainable-design considerations for specific product function. For instance, a durable product that lasts longer does not require frequent replacement. Disassembly, repair, reusability, and recyclability are other critical elements of sustainable design. The design of a product that requires a combination of materials such as metals, plastics, and composites must take into consideration the disassembly of each material for recycling; otherwise, the entire product must be discarded. Instead of using adhesives, custom fasteners, or welding to create an inseparable assembly that can only be discarded as a whole, companies can design products that disassemble for service and recycling of specific components. Painting and adding other finishes to materials often limits their recyclability. Consideration should be given to the tools required to most easily service and recycle the design. Ideally, products should disassemble using the same tool, common fasteners, the fewest number of possible fasteners, or clearly accessible and durable snap-fit connections that require no tools.

Manufacturing practices are other important considerations for sustainable design. An example of sustainable manufacturing is minimizing energy consumption by investing in production systems and equipment that are more efficient and using clean energy technologies. Additional examples of sustainable manufacturing include designing products to reduce processing and handling, and choosing manufacturing processes and materials that do not create hazardous waste.

## SUSTAINABLE CAD

CAD offers tools that significantly improve the ability to apply sustainable-design practices. Software is available that assists all elements of sustainable design from manufacturing material selection and usage to product life cycle assessment. A powerful example of sustainable design with CAD is developing a digital prototype of a product as a 3-D solid model. Digital prototyping was described in the Prototyping section earlier in this chapter. Digital prototyping can support sustainable design by leading to lower costs, reduced material consumption, and optimized use of energy. CAD allows the design process to occur in significantly less time, using fewer engineers and technicians, and reducing physical prototypes, which are expensive and time consuming to create and test. The following information describes how Utility Scale Solar, Inc. (USS; <http://www.utilityscalesolar.com>) uses CAD technology to optimize the cost and material use in solar energy production.

USS manufactures **solar tracking** equipment for large-scale solar power plants (see Figure 3.61). Solar tracking equipment, such as the USS Megahelion™ MH144 heliostat,



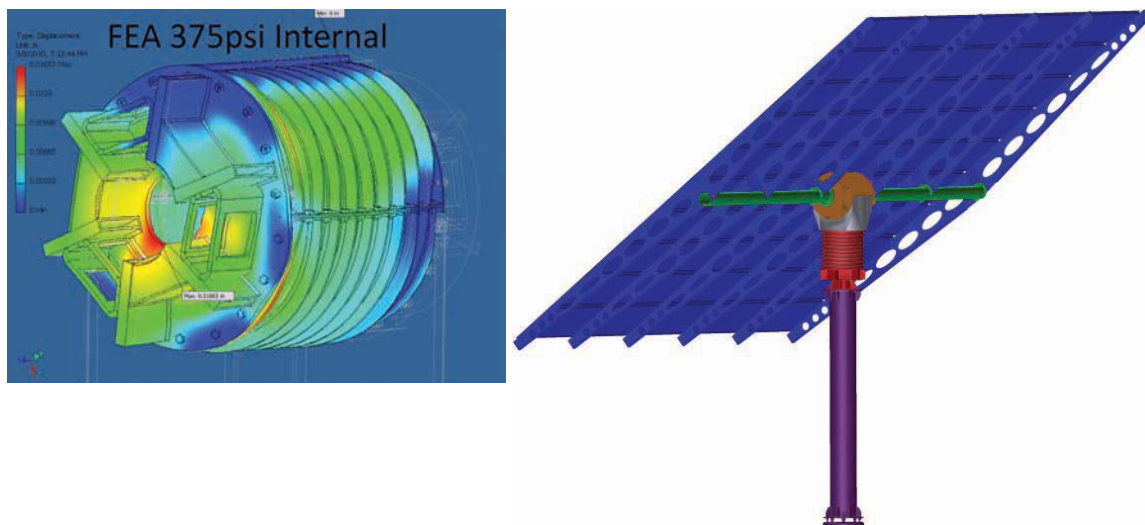
**FIGURE 3.61** An example of a solar energy collection unit for a large-scale solar power plant. *Image copyright 2010 Utility Scale Solar, Inc. U.S. and International Patents Pending*

accurately follows the sun as it moves across the sky to position solar reflecting surfaces, or solar panel arrays, for the best collection of solar energy. Solar collection units are very large, about three stories tall, and each solar power plant includes thousands of units. Therefore, reducing the weight and increasing the efficiency of solar tracking equipment can provide significant material and energy savings.

The patent-pending Megahelion drive and heliostat product is resistant to wind, dust, weight, and weather, which are common issues affecting the performance of solar tracking machinery. The Megahelion uses fewer moving parts, stronger components, and a system that distributes forces over a larger surface area than conventional drives, resulting in a fluid motion with fewer breakdowns and much lower ownership and operating costs. Unlike traditional drives that use gears or conventional hydraulics, the Megahelion™ drive uses flexible hydraulic cells to position the drive shaft.

USS relies heavily on modern CAD technology for digital prototyping. USS uses Autodesk Inventor and Algor® software for design, dynamic simulation, and finite element analysis (FEA). USS also uses Autodesk Vault Manufacturing software to manage CAD data and Autodesk Showcase® software to prepare images and 3-D visualizations for sales and marketing. According to Jonathan Blitz, USS's chief technical officer, “The software has significantly streamlined what we are doing and made it much easier to visualize and communicate our designs. The ability to then subject these designs to realistic forces and loads has given us the confidence to remove mass and streamline the components without sacrificing structural integrity.”

An example of CAD optimization at USS is the redesign of an endcap for the Megahelion solar tracker. Figure 3.62 shows the 3-D solid model and FEA analysis of the original endcap design. The original component weighs 650 pounds, is overdesigned, and uses a cylindrical drum with a flat endcap. The objective was to redesign the part to distribute loads more effectively, enabling a reduction in material use and mass.



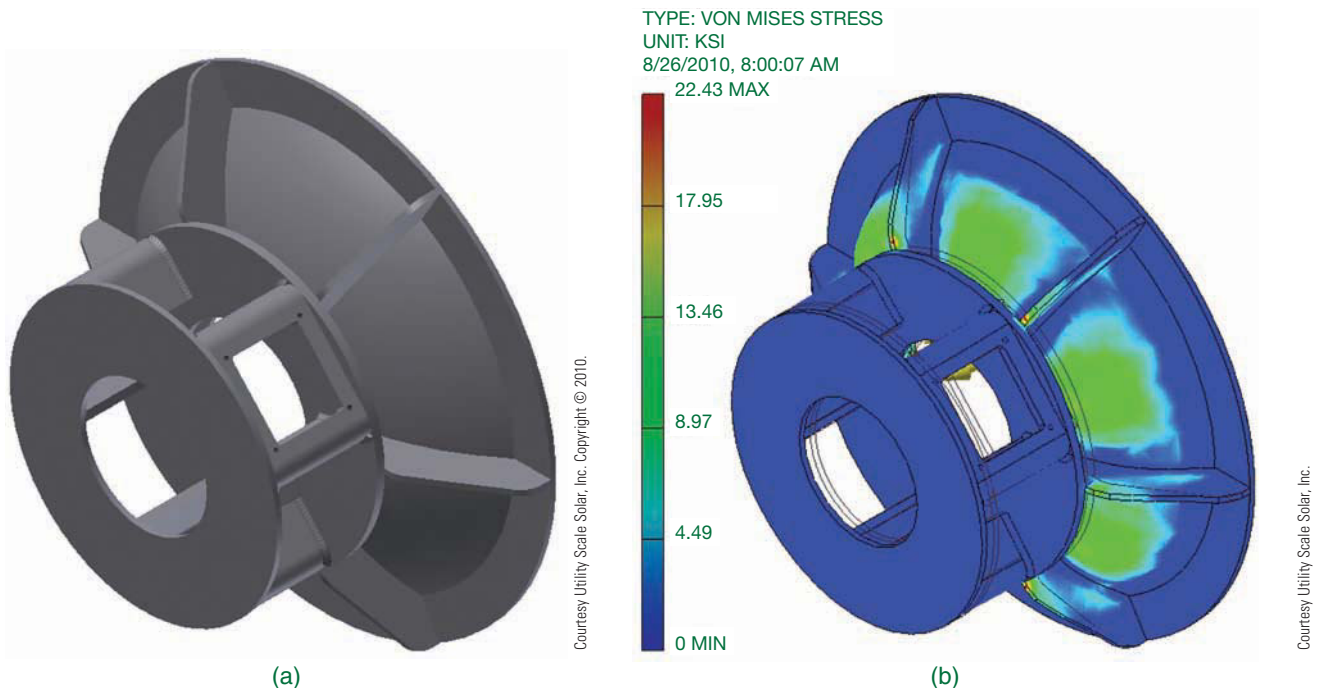
**FIGURE 3.62** A component to be redesigned to use less material and improve performance. *Courtesy Utility Scale Solar, Inc.*



**FIGURE 3.63** (a) The design of the initial digital prototype of the endcap. (b) A simulation of the resulting design under the loads from internal pressure.

The focus of the endcap redesign was changing to a hemispherical shape that would bear weight and wind loads more efficiently and naturally than a flat end plate. Figure 3.63 shows a digital prototype of an early, non-optimized redesign. USS used Autodesk Inventor 3-D solid modeling and stress analysis tools to simulate and test design options, including varying the depth of the hemisphere, the thickness of the shell, and the number of reinforcing ribs. Autodesk Inventor parametric optimization capabilities allowed USS engineers to optimize the design for reduced mass and automatically validate the design against project requirements.

After analysis, USS determined a more optimal design with a wall thickness of .5 in., an endcap depth of 6 in., and six ribs (see Figure 3.64a). The simulation results show that stress and safety factors are within the specifications set by the design team. Compared to the original endcap design in Figure 3.62, the redesigned endcap uses less material in low-stress areas, shows less dramatic stress concentrations, and distributes the load more evenly and efficiently. The mass of the new design is 481 pounds, making it 26% lighter than the original part. USS now has an accurate concept of a product that should perform better, require less material and energy to produce and handle, and cost less to manufacture and transport.



**FIGURE 3.64** (a) The design of the final digital prototype of the endcap optimized for weight and function. (b) A simulation of the resulting design under the loads from internal pressure.

## PROFESSIONAL PERSPECTIVE

A wide variety of jobs are available for qualified CADD professionals. Keep in mind that the kinds of tasks may not always be traditional drafting functions. In addition to creating drawings, you can be responsible for working in some of the following areas:

- Preparing freehand sketches on the shop floor or at a job site and then converting the sketch to a finished CADD drawing.
- Digital image creation and editing.
- Text documents such as reports, proposals, and studies.
- Incorporation of CADD drawings and images into text documents.
- Conducting research for job proposals, feasibility studies, or purchasing specifications.
- Evaluating and testing new software.
- Training staff members in the use of new software or procedures.
- Collecting vendor product information for new projects.
- Speaking on the phone and dealing personally with vendors, clients, contractors, and engineers.
- Checking drawings and designs created by others for accuracy.
- Researching computer equipment and preparing bid specifications for purchase.

Human-resource directors who most often hire employees agree that persons who possess a set of good general skills usually become good employees. The best jobs are found by those students who have developed a good working understanding of the project-planning process and can apply it to

any situation. The foundation on which this process is based rests on the person's ability to communicate well orally, apply solid math skills (through trigonometry), write clearly, exhibit good problem-solving skills, and know how to use resources to conduct research and find information.

These general qualifications also serve as the foundation for the more specific skills of your area of study. These include a good working knowledge of drawing layout and construction techniques based on applicable standards, and a good grasp of CADD software used to create drawings and models. In addition, those students who possess the skills needed to customize the CADD software to suit their specific needs may be in demand.

What is most important for the prospective drafter to remember is the difference between content and process. This was discussed previously in this chapter but deserves a quick review. **Content** applies to the details of an object, procedure, or situation. Given enough time, you can find all of the pieces of information needed to complete a task, such as creating a drawing or designing a model. **Process** refers to a method of doing something, usually involving a number of steps. By learning a useful process, you will find it easier to complete any task and find all of the information (content) you need. It is beneficial to learn a good process for problem solving and project planning that can be used in any situation. By using the process for any task, it becomes easier to determine what content is needed.

For these reasons, it is strongly recommended that you focus your efforts on learning and establishing good problem-solving and project-planning habits. These skills make the task of locating the content you need for any project easier and contribute to making all aspects of your life more efficient, productive, and relaxing.

## WEB SITE RESEARCH

Use the following Web sites as a resource to help find more information related to engineering drawing and design and the content of this chapter.

Address	Company, Product, or Service
imsidesign.com	IMSI/Design CADD software
sketchup.google.com	Google SketchUp 3-D modeling software
www.3ds.com	Dassault Systèmes CADD software
www.adda.org	American Design Drafting Association and American Digital Design Association (ADDA International)
www.aia.org	American Institute of Architects (AIA)
www.alibre.com	Alibre, Inc. CADD software
www.amazon.com	Search author, Madsen, for the following CADD textbook titles
www.ansi.org	American National Standards Institute (ANSI)
www.ashlar.com	Ashlar-Vellum CADD software
www.asme.org	American Society of Mechanical Engineers (ASME)

(Continued)

www.autodesk.com	Autodesk, Inc. CADD software
www.bentley.com	Bentley Systems, Inc. CADD software
www.cad-forum.com	CAD Forum
www.mechdyne.com/	Mechdyne Corporation virtual reality products
www.graphisoft.com	GRAPHISOFT CADD software
www.g-w.com	Publisher of CADD textbooks by David A. Madsen and David P. Madsen
www.intergraph.com	Intergraph CADD software
www.ironcad.com	IronCAD CADD software
www.kubotekusa.com	Kubotek Corporation CADD software
www.nacfam.org	National Coalition for Advanced Manufacturing (NACFAM)
www.nationalcadstandard.org	United States National CAD Standard (NCS)
www.plm.automation.siemens.com	Siemens PLM Solutions software
www.ptc.com	Parametric Technology Corporation CADD software
www.sensable.com	SensAble Technologies
www.solidworks.com	Dassault Systèmes SolidWorks CADD software
www.virtualresearch.com	Virtual Research Systems

## Chapter 3

### Chapter 3 Computer-Aided Design and Drafting (CADD) Test



To access the Chapter 3 test, go to the Student CD, select **Chapter Tests and Problems**, and then **Chapter 3**. Answer the questions

with short, complete statements, sketches, or drawings as needed. Confirm the preferred submittal process with your instructor.

### Chapter 3 Computer-Aided Design and Drafting (CADD) Problems

#### INSTRUCTIONS

Select one or more of the following problem topic areas as determined by your instructor or course guidelines and write a 300- to 500-word report on the selected topic or topics. Prepare each report using a word processor. Use double spacing, proper grammar and spelling, and illustrative examples where appropriate. Use, but do not copy, the information found in this chapter and additional research information.

#### Part 1: Problems 3.1 Through 3.25

- PROBLEM 3.1** Use of CADD in the engineering design process.
- PROBLEM 3.2** CADD workstation and computer equipment.
- PROBLEM 3.3** Specific CADD software product.
- PROBLEM 3.4** Two-dimensional CADD applications.

- PROBLEM 3.5** Three-dimensional surface model applications.
- PROBLEM 3.6** Three-dimensional solid model applications.
- PROBLEM 3.7** Product life cycle management (PLM) software.
- PROBLEM 3.8** Web-based design and drafting collaboration.
- PROBLEM 3.9** Digital prototyping of a specific product or as used by a specific company.
- PROBLEM 3.10** Rapid prototyping (RP) applications.
- PROBLEM 3.11** Rapid injection modeling of a specific product or as used by a specific company.

- PROBLEM 3.12 Subtractive rapid prototyping of a specific product or as used by a specific company.
- PROBLEM 3.13 Computer-aided engineering (CAE) applications.
- PROBLEM 3.14 Animation used in the design of a specific product or as used by a specific engineering company.
- PROBLEM 3.15 Computer-aided manufacturing (CAM) applications.
- PROBLEM 3.16 Computer-integrated manufacturing (CIM) of a specific product or as used by a specific engineering company.
- PROBLEM 3.17 CADD related to technical illustration.
- PROBLEM 3.18 Virtual reality (VR) in engineering drawing and design.
- PROBLEM 3.19 Operation and techniques associated with a specific CADD software.
- PROBLEM 3.20 Surface modeling of a specific product or as used by a specific engineering company.
- PROBLEM 3.21 Solid modeling of a specific product or as used by a specific engineering company.
- PROBLEM 3.22 ASME Y14.41 CADD standard.
- PROBLEM 3.23 United States National CAD Standard (NCS).
- PROBLEM 3.24 Productivity with CADD.
- PROBLEM 3.25 CADD workstation ergonomics.

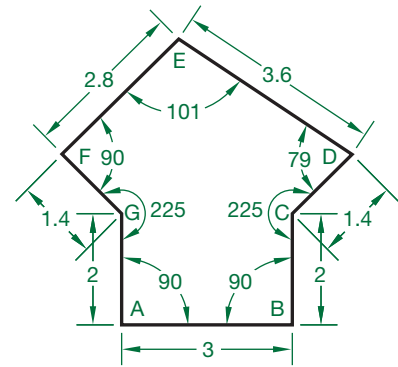
**Math Problems**

**Part 2: Problems 3.26 and 3.27**

PROBLEM 3.26 Draw the following sheet metal part using CADD software. Use the entry method of your choice. Space is provided in which you can write the

coordinate values needed to draw a line to each point—or use a separate sheet.

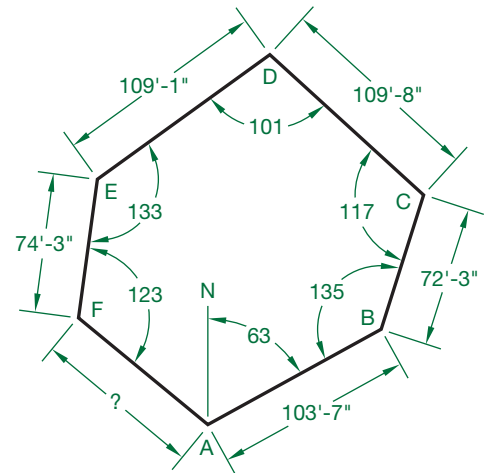
- A to B \_\_\_\_\_
- B to C \_\_\_\_\_
- C to D \_\_\_\_\_
- D to E \_\_\_\_\_
- E to F \_\_\_\_\_
- F to G \_\_\_\_\_
- G to A \_\_\_\_\_



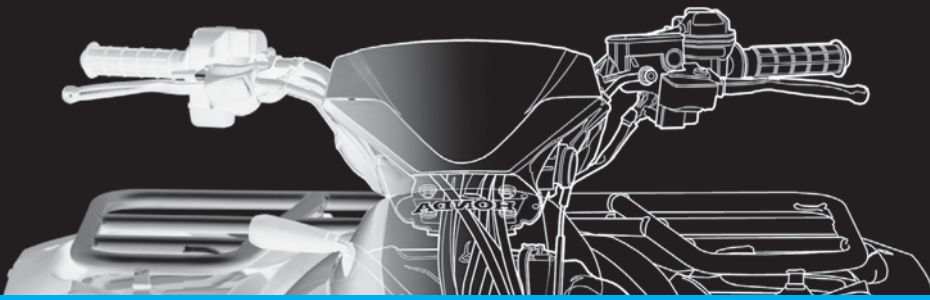
© Cengage Learning 2012

PROBLEM 3.27 The following property plat has been given to you in the form of a sketch with included angles. You are to draw the property plat full size using the dimensions given. Do not use decimal values for angles or distances. Space is provided in which you can write the coordinate values needed to draw a line to each point. Write your answers using a polar coordinate notation. For example, a line 87'-3" long, at an angle of 65° is written @ 87'3" < 65.

- A to B \_\_\_\_\_
- B to C \_\_\_\_\_
- C to D \_\_\_\_\_
- D to E \_\_\_\_\_
- E to F \_\_\_\_\_
- F to A \_\_\_\_\_



© Cengage Learning 2012



# CHAPTER 4

## Manufacturing Materials and Processes

### LEARNING OBJECTIVES

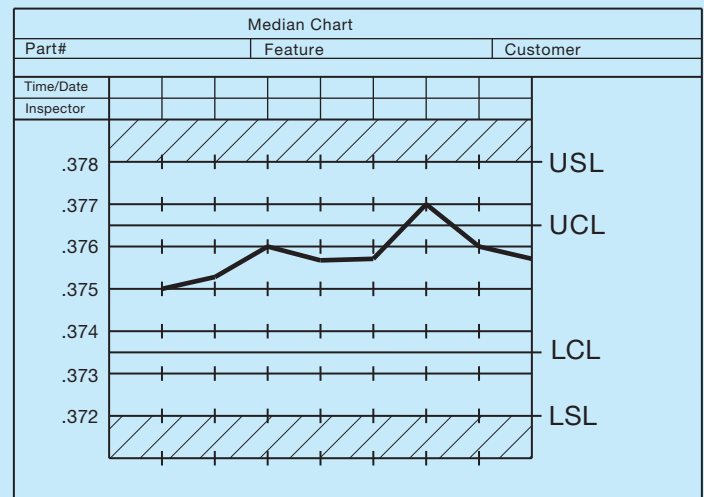
After completing this chapter, you will:

- Define and describe given manufacturing materials, material terminology, numbering systems, and material treatment.
- Describe steel and aluminum material selection characteristics.
- Explain sustainability applications for steel and aluminum processing and manufacturing.
- Identify a variety of manufacturing processes used to create plastic products.
- Explain sustainability applications for plastics processing and manufacturing.
- Discuss casting processes and terminology.
- Explain the forging process and terminology.
- Describe manufacturing processes.
- Define and draw the representation of various machined features.
- Explain tool design and drafting practices.
- Draw a basic machine tool.
- Discuss the statistical process quality control assurance system.
- Evaluate the results of an engineering and manufacturing problem.
- Explain the use of computer-aided manufacturing (CAM) in industry.
- Discuss robotics in industry.

## THE ENGINEERING DESIGN APPLICATION

Your company produces die cast aluminum parts. A customer has explained that any delay in parts shipment requires them to shut down a production line. It is very costly. It is critical to your customer that certain features on its castings fall within specification limits, and the engineering department has decided to develop an early warning system in an attempt to prevent production delays.

You are asked to develop new quality control charts with two levels of control. The maximum allowable deviation is indicated by the upper and lower specification limits as specified by the dimensional tolerances on the part drawing. A mean value is established between the nominal dimension and dimensional limits, and these are set up as upper and lower control limits. The chart instructs the inspector to notify the supervisor immediately if the feature falls outside of control limits and to halt production if it is outside of specification limits. This provides a means of addressing problems before they can interfere with production, shifting the emphasis from revision to prevention. Figure 4.1 shows a sample chart with two levels of control.



**FIGURE 4.1** Sample quality control chart with both control and specifications limits. © Cengage Learning 2012



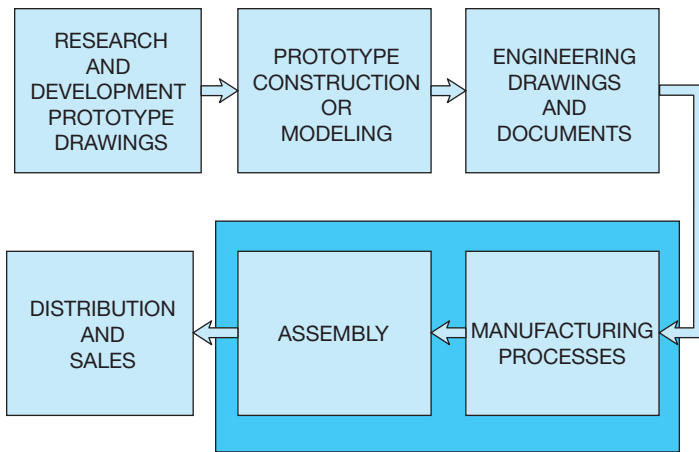


FIGURE 4.2 Sequence of product development. © Cengage Learning 2012

## INTRODUCTION

A number of factors influence product manufacturing. Beginning with **research and development (R&D)**, a product should be designed to meet a market demand, have good quality, and be economically produced. R&D is the first phase used to determine the feasibility of new products or the evolution of existing products using creativity, market research, product research, and prototype development. The sequence of product development begins with an idea and results in a marketable commodity as shown in Figure 4.2.

## MANUFACTURING MATERIALS

A wide variety of materials available for product manufacturing fall into three general categories: metal, plastic, and inorganic materials. Metals are classified as ferrous, nonferrous, and alloys. **Ferrous metals** contain iron in some form such as cast iron and steel. **Nonferrous metals** do not have iron content; for example, copper and aluminum. **Alloys** are mixtures of two or more metals.

**Plastics** or **polymers** have two types of structure: thermoplastic and thermoset. **Thermoplastic** material can be heated and formed by pressure and the shape can be changed on reheating. **Thermoset** plastics are formed into a permanent shape by heat and pressure and cannot be altered by heating after curing. Plastics are molded into shape and only require machining for tight tolerance situations or when holes or other features are required, features that would be impractical to produce in a mold. It is common practice to machine some plastics for parts, such as gears and pinions.

**Inorganic materials** include carbon, ceramics, and composites. Carbon and graphite are classified together and have properties that allow molding by pressure. These materials have low **tensile strength** (the ability to be stretched) and high compressive strength, with increasing strength at increased temperatures. Ceramics are clay, glass, refractory, and inorganic cements. Ceramics are very hard, brittle materials that are resistant to heat, chemicals, and corrosion. Clay and glass materials have an amorphous structure, whereas **refractories** must be bonded together by applying temperatures. A refractory is a nonmetallic material

that retains its strength under high temperatures. Because of their great heat resistance, refractories are used for high-temperature applications such as furnace liners. **Composites** are two or more materials that are bonded together by **adhesion**, a force that holds together the molecules of unlike substances when the surfaces come in contact. These materials generally require carbide cutting tools or special methods for machining.

## Ferrous Metals

The two main types of ferrous metals are cast iron and steel. These metals contain iron. There are many classes of cast iron and steel that are created for specific types of application based on their composition.

### Cast Iron

There are several classes of **cast iron**, including gray, white, chilled, alloy, malleable, and nodular. Cast iron is primarily an alloy of iron and 1.7% to 4.5% of carbon, with varying amounts of silicon, manganese, phosphorus, and sulfur.

#### Gray Cast Iron

**Gray iron** is a popular casting material for automotive cylinder blocks, machine tools, agricultural implements, and cast iron pipe. Gray cast iron is easily cast and machined. It contains 1.7% to 4.5% carbon and 1% to 3% silicon.

#### STANDARDS

**ASTM** The American Society for Testing Materials (ASTM) specifications A48–76 group gray cast iron into two classes: (1) easy to manufacture (20A, 20B, 20C, 25A, 25B, 25C, 30A, 30B, 30C, 35A, 35B, 35C) and (2) more difficult to manufacture (40B, 40C, 45B, 45C, 50B, 50C, 60B, 60C). The prefix number denotes the minimum tensile strength in thousand of pounds per square inch. For more information or to order standards, go to the ASTM Web site at [www.astm.org](http://www.astm.org).

#### White Cast Iron

**White cast iron** is extremely hard and brittle, and it has almost no ductility. **Ductility** is the ability to be stretched, drawn, or hammered thin without breaking. Caution should be exercised when using this material because thin sections and sharp corners may be weak, and the material is less resistant to impact uses. This cast iron is suited for products with more compressive strength requirements than gray cast iron [compare more than 200,000 pounds per square inch (psi) with 65,000 to 160,000 psi]. White cast iron is used where high wear resistance is required.

#### Chilled Cast Iron

An outer surface of white cast iron results when gray iron castings are chilled rapidly. This chilled cast iron material has the internal characteristics of gray cast iron and the surface advantage of white cast iron.

## Alloy Cast Iron

Elements such as nickel, chromium, molybdenum, copper, or manganese can be alloyed with cast iron to increase the properties of strength, wear resistance, corrosion resistance, or heat resistance. Alloy iron castings are commonly used for such items as pistons, crankcases, brake drums, and crushing machinery.

## Malleable Cast Iron

The term **malleable** means the ability to be hammered or pressed into shape without breaking. Malleable cast iron is produced by heat-treating white cast iron. The result is a stronger, more ductile, and shock-resistant cast iron that is easily machinable.

### STANDARDS

**ASTM** The ASTM standard, ASTM A47-77 provides specifications for malleable cast iron.

## Nodular Cast Iron

**Nodular cast iron** is created with special processing procedures, along with the addition of magnesium- or cerium-bearing alloys, that result in a cast iron with spherical-shaped graphite rather than flakes, as in gray cast iron. The results are iron castings with greater strength and ductility. Nodular cast iron can be chilled to form a wear-resistant surface ideal for use in crankshafts, anvils, wrenches, or heavy-use levers.

## Steel

**Steel** is an alloy of iron containing 0.8% to 1.5% carbon. Steel is a readily available material that can be worked in either a heated or a cooled state. The properties of steel can be changed by altering the carbon content and heat-treating. **Mild steel (MS)** is low in carbon (less than 0.3%) and commonly used for forged and machined parts, but it cannot be hardened. **Medium-carbon steel** (0.3% to 0.6% carbon) is harder than mild steel, yet remains easy to forge and machine. **High-carbon steel** (0.6% to 1.50% carbon) can be hardened by heat-treating, but it is difficult to forge, machine, or weld.

**Hot-rolled steel (HRS)** characterizes steel that is formed into shape by pressure between rollers or by forging when in a red-hot state. When in this hot condition, the steel is easier to form than when it is cold. An added advantage of hot forming is a consistency in the grain structure of the steel, which results in a stronger, more ductile metal. The surface of hot-rolled steel is rough, with a blue-black oxide buildup. The term **cold-rolled steel (CRS)** implies the additional forming of steel after initial hot rolling. The cold-rolling process is used to clean up hot-formed steel, provide a smooth and clean surface, ensure dimensional accuracy, and increase the tensile strength of the finished product.

**Steel alloys** are used to increase such properties as hardness, strength, corrosion resistance, heat resistance, and wear resistance. **Chromium steel** is the basis for stainless steel and is used where corrosion and wear resistance is required.

Manganese alloyed with steel is a purifying element that adds strength for parts that must be shock and wear resistant. Molybdenum is added to steel when the product must retain strength and wear resistance at high temperatures. When tungsten is added to steel, the result is a material that is very hard and ideal for use in cutting tools. Tool steels are high in carbon, alloy content, or both so that the steel will hold an edge when cutting other materials. When the cutting tool requires deep cutting at high speed, then the alloy and hardness characteristics are improved for a classification known as **high-speed steel**. Vanadium alloy is used when a tough, strong, nonbrittle material is required.

**Steel castings** are used for machine parts where the use requires heavy loads and the ability to withstand shock. These castings are generally stronger and tougher than cast iron. Steel castings have uses as turbine wheels, forging presses, gears, machinery parts, and railroad car frames.

## Stainless Steel

**Stainless steels** are high-alloy chromium steels that have excellent corrosion resistance. In general, stainless steels contain at least 10.5% chromium, with some classifications of stainless steel having between 4% and 30% chromium. In addition to corrosion resistance properties, stainless steel can have oxidation and heat resistance and can have very high strength. Stainless steel is commonly used for restaurant and hospital equipment and for architectural and marine applications. The high strength-to-weight ratio also makes stainless steel a good material for some aircraft applications.

Stainless steel is known for its natural luster and shine, which make it look like chrome. It is also possible to add color to stainless steel, which is used for architectural products such as roofing, hardware, furniture, kitchen, and bathroom fixtures.

The American Iron and Steel Institute (AISI) ([www.steel.org](http://www.steel.org)) identifies stainless steels with a system of 200, 300, or 400 series numbers. The 200 series stainless steels contain chromium, nickel, and manganese; the 300 series steels have chromium and nickel; and the 400 series steels are straight-chromium stainless steels.

## Steel Numbering Systems

### STANDARDS

**AISI/SAE** The American Iron and Steel Institute (AISI) and the Society of Automotive Engineers (SAE) provide similar steel numbering systems. Steels are identified by four numbers, except for some chromium steels, which have five numbers. For a steel identified as SAE 1020, the first two numbers (10) identify the type of steel, and the last two numbers (20) specify the approximate amount of carbon in hundredths of a percent (0.20% carbon). The letter L or B can be placed between the first and second pair of numbers. L means that lead is added to improve machinability, and B identifies a boron steel. The prefix E means that the steel is made using the

electric-furnace method. The prefix H indicates that the steel is produced to hardenability limits. Steel that is de-gassed and deoxidized before solidification is referred to as **killed steel** and is used for forging, heat-treating, and difficult stampings. Steel that is cast with little or no de-gasification is known as **rimmed steel** and has applications where sheets, strips, rods, and wires with excellent surface finish or drawing requirements are needed.

## Examples of SAE Steel Numbering Applications

The following is a small sample of general steel material selection applications based on use and related to the SAE numbering system.

Application	SAE Number
Agricultural steel	1070, 1080
Axle shafts	1045, 2340, 3140, 4340
Bolts and screws	1035
Bolts, heavy duty	4815, 4820
Coil springs	4063
Cold-rolled steel	1070
Crankshafts	1045, 1145, 3140
Forgings, carbon steel	1040, 1045
Forgings, heat-treated	3240, 5140, 6150
Gears	1320, 2317, 3120, 4125, 4620
Nuts	3130
Propeller shafts	2340, 2345
Transmission shafts	4140
Washers, lock	1060
Wire, music	1085

General applications of SAE steels are shown in Appendix D. For a more in-depth analysis of steel and other metals, refer to the *Machinery's Handbook*.<sup>\*</sup> Additional information about numbering systems is provided later in this chapter. For more information about AISI or to order standards, go to the AISI Web site at [www.aisi.org](http://www.aisi.org). For more information about SAE or to order standards, go to the SAE Web site at [www.sae.org](http://www.sae.org).

## Hardening of Steel

The properties of steel can be altered by **heat-treating**. Heat-treating is a process of heating and cooling steel using specific controlled conditions and techniques. Steel is fairly soft when initially formed and allowed to cool naturally. **Normalizing** is a process of heating the steel to a specified temperature and then allowing the material to cool slowly by air, which brings the steel to a normal state. To harden the steel, the metal is first heated to a specified temperature, which varies with different steels. Next, the steel is **quenched**, which means it is cooled

suddenly by plunging it into water, oil, or other liquid. Steel can also be **case-hardened** using a process known as **carburization**. *Case replace hyphen by space hardening* refers to the hardening of the surface layer of the metal. Carburization is a process in which carbon is introduced into the metal by heating to a specified temperature range while in contact with a solid, liquid, or gas material consisting of carbon. This process is often followed by quenching to enhance the hardening process. **Tempering** is a process of reheating normalized or hardened steel through a controlled process of heating the metal to a specified temperature, followed by cooling at a predetermined rate to achieve certain hardening characteristics. For example, the tip of a tool may be hardened while the rest of the tool remains unchanged.

Under certain heating and cooling conditions and techniques, steel can also be softened using a process known as **annealing**.

## Hardness Testing

There are several methods of checking material hardness. The techniques have common characteristics based on the depth of penetration of a measuring device or other mechanical systems that evaluate hardness. The Brinell and Rockwell hardness tests are popular. The **Brinell test** is performed by placing a known load, using a ball of a specified diameter, in contact with the material surface. The diameter of the resulting impression in the material is measured and the Brinell hardness number (BHN) is then calculated. The **Rockwell hardness test** is performed using a machine that measures hardness by determining the depth of penetration of a spherically shaped device under controlled conditions. There are several Rockwell hardness scales, depending on the type of material, the type of penetrator, and the load applied to the device. A general or specific note on a drawing that requires a hardness specification may read: CASE HARDEN 58 PER ROCKWELL "C" SCALE. For additional information, refer to the *Machinery's Handbook*.

## Nonferrous Metals

Nonferrous metals do not contain iron and have properties that are better suited for certain applications where steel may not be appropriate.

### Aluminum

**Aluminum** is corrosion resistant, lightweight, easily cast, conductive of heat and electricity, and very malleable, and it can be easily **extruded**. Extruding is shaping the metal by forcing it through a die. Pure aluminum is seldom used, but alloying it with other elements provides materials that have an extensive variety of applications. Some aluminum alloys lose strength at temperatures generally above 250°F (121°C) but gain strength at cold temperatures. There are a variety of aluminum alloy numerical designations used. A two- or three-digit number is used, and the first digit indicates the alloy type, as follows: 1 = 99% pure, 2 = copper, 3 = manganese, 4 = silicon, 5 = magnesium, 6 = magnesium and silicon, 7 = zinc, and 8 = other. For designations above 99%, the last

<sup>\*</sup>Erick Oberg, Franklin D. Jones, and Holbrook L. Horton, *Machinery's Handbook*, 28th ed. (New York: Industrial Press, Inc.).

two digits of the code are the amount over 99%. For example, 1030 means 99.30% aluminum. The second digit is any number between 0 and 9 where 0 means no control of specific impurities and numbers 1 through 9 identify control of individual impurities.

### Copper Alloys

**Copper** is easily rolled and drawn into wire, has excellent corrosion resistance, is a great electrical conductor, and has better ductility than any metal except for silver and gold. Copper is alloyed with many different metals for specific advantages, which include improved hardness, casting ability, machinability, corrosion resistance, elastic properties, and lower cost.

### Brass

**Brass** is a widely used alloy of copper and zinc. Its properties include corrosion resistance, strength, and ductility. For most commercial applications, brass has about a 90% copper and 10% zinc content. Brass can be manufactured by any number of processes, including casting, forging, stamping, or drawing. Its uses include valves, plumbing pipe and fittings, and radiator cores. Brass with greater zinc content can be used for applications requiring greater ductility, such as cartridge cases, sheet metal, and tubing.

### Bronze

**Bronze** is an alloy of copper and tin. Tin in small quantities adds hardness and increases wear resistance. Tin content in coins and medallions, for example, ranges from 4% to 8%. Increasing amounts of tin also improves the hardness and wear resistance of the material but causes brittleness. Phosphorus added to bronze (phosphor bronze) increases its casting ability and aids in the production of more solid castings, which is important for thin shapes. Other materials such as lead, aluminum, iron, and nickel can be added to copper for specific applications.

## Precious and Other Specialty Metals

**Precious metals** include gold, silver, and platinum. These metals are valuable because they are rare, costly to produce, and have specific properties that influence use in certain applications.

### Gold

Gold for coins and jewelry is commonly hardened by adding copper. Gold coins, for example, are 90% gold and 10% copper. The term *carat* refers to the purity of gold, where 1/24 gold is one carat. Therefore,  $24 \times 1/24$  or 24 carats is pure gold. Fourteen-carat gold, for example, is 14/24 gold. Gold is extremely malleable, corrosion resistant, and the best conductor of electricity. In addition to use in jewelry and coins, gold is used as a conductor in some electronic circuitry applications. Gold is also used in applications where resistance to chemical corrosion is required.

### Silver

**Silver** is alloyed with 8% to 10% copper for use in jewelry and coins. Sterling silver for use in such items as eating utensils and other household items is 925/1000 silver. Silver is easy to shape, cast, or form, and the finished product can be polished to a high-luster finish. Silver has uses similar to gold because of its corrosion resistance and ability to conduct electricity.

### Platinum

**Platinum** is rarer and more expensive than gold. Industrial uses include applications where corrosion resistance and a high melting point are required. Platinum is used in catalytic converters because it has the unique ability to react with and reduce carbon monoxide and other harmful exhaust emissions in automobiles. The high melting point of platinum makes it desirable in certain aerospace applications.

### Columbium

**Columbium** is used in nuclear reactors because it has a very high melting point—4380°F (2403°C)—and is resistant to radiation.

### Titanium

**Titanium** has many uses in the aerospace and jet aircraft industries because it has the strength of steel and the approximate weight of aluminum, and it is resistant to corrosion and temperatures up to 800°F (427°C).

### Tungsten

**Tungsten** has been used extensively as the filament in light-bulbs because of its ability to be drawn into very fine wire and its high melting point. Tungsten, carbon, and cobalt are formed together under heat and pressure to create tungsten carbide, the hardest human-made material. **Tungsten carbide** is used to make cutting tools for any type of manufacturing application. Tungsten carbide saw-blade inserts are used in saws for carpentry so the cutting edge will last longer. Such blades make a finer and faster cut than plain steel saw blades.

## A Unified Numbering System for Metals and Alloys

Many numbering systems have been developed to identify metals. The organizations that developed these numbering systems include the American Iron and Steel Institute (AISI), Society of Automotive Engineers (SAE), American Society for Testing Materials (ASTM), American National Standards Institute (ANSI), Steel Founders Society of America (SFSA), American Society of Mechanical Engineers (ASME), American Welding Society (AWS), Aluminum Association, and Copper Development Association (CDA), as well as military specifications by the United States Department of Defense and federal specifications by the Government Accountability Office.

A combined numbering system created by the ASTM and the SAE was established in an effort to coordinate all the different numbering systems into one system. This system avoids the possibility that the same number might be used for two different metals. This combined system is the **Unified Numbering System (UNS)**. The UNS is an identification numbering system for commercial metals and alloys. It does not provide metal and alloy specifications.

The UNS system is divided into the following categories.

UNS SERIES METAL	
UNS Series	Metal
<b>Nonferrous Metals and Alloys</b>	
A00001 to A99999	Aluminum and aluminum alloys
C00001 to C99999	Copper and copper alloys
E00001 to E99999	Rare-earth and rare-earth-like metals and alloys
L00001 to L99999	Low-melting metals and alloys
M00001 to M99999	Miscellaneous metals and alloys
P00001 to P99999	Precious metals and alloys
R00001 to R99999	Reactive and refractory metals and alloys
Z00001 to Z99999	Zinc and zinc alloys
<b>Ferrous Metals and Alloys</b>	
D00001 to D99999	Specified mechanical properties steels
F00001 to F99999	Cast irons
G00001 to G99999	AISI and SAE carbon and alloy steels, excluding tool steels
H00001 to H99999	AISI H-classification steels
J00001 to J99999	Cast steels, excluding tool steels
K00001 to K99999	Miscellaneous steels and ferrous alloys
S00001 to S99999	Stainless steels
T00001 to T99999	Tool steels

The prefix letters of the UNS system often match the type of metal being identified—for example, A for aluminum, C for copper, and T for tool steels. Elements of the UNS numbers typically match numbers provided by other systems—for example, SAE1030 is G10300 in the UNS system.

## METALLURGY

**Metallurgy** is the part of **materials science** that studies the physical and chemical behavior of metals and alloys. Metallurgy is also applied to the practical use of metals. Metallurgy is commonly used in the craft of metalworking. Materials science deals with fundamental properties and characteristics of materials and material applications. The person performing metallurgy applications is a **metallurgist**.

Common engineering metals were described and their common uses identified in the previous sections. Manufacturing materials are often used as alloys where characteristics are

needed such as resistance to corrosion, strength, lightweight, and high-temperature applications. Metallurgy also involves the production of metal components for use in products. This involves alloy development, material shaping, heat treatment, and the surface treatment of materials to be used in products. The metallurgist actively seeks a balance between material properties such as weight, strength, toughness, hardness, corrosion and fatigue resistance, and performance in temperature extremes, along with cost considerations. To achieve this goal, the operating environment must be carefully considered. Operating environments that can cause especially difficult metallurgy requirements include saltwater where ferrous metals and some aluminum alloys corrode quickly; extreme cold or conditions where metals can become brittle and crack more easily; continuous cyclic loading, which can cause metal fatigue; and constant stress at elevated temperatures, which can cause permanent deformation.

## PLASTICS AND POLYMERS

A **plastic** is generally defined as any complex, organic, polymerized compound capable of being formed into a desired shape by molding, casting, or spinning. Plastic retains its shape under ordinary conditions of temperature. **Polymerization** is a process of joining two or more molecules to form a more complex molecule with physical properties that are different from the original molecules. The terms *plastic* and *polymer* are often used to mean the same thing. Plastics can exist in any state from liquid to solid. The main elements of plastic are generally common petroleum products, crude oil, and natural gas.

## GREEN TECHNOLOGY APPLICATION

The following is taken in part from *Aluminum for Future Generations*, published by the International Aluminum Institute (IAI) ([www.world-aluminum.org](http://www.world-aluminum.org)).



### Aluminum for Future Generations

For more information about the Green Technology Application Aluminum for Future Generations, go to the Student CD, select **Supplemental Material, Chapter 4**, and then **Green Technology Application Aluminum for Future Generations**.

**Rubber** is an elastic hydrocarbon polymer that occurs as a milky emulsion known as **latex**, which is naturally found in the sap of a number of plants but can also be produced synthetically. More than half of the rubber used today is synthetic, but several million tons of natural rubber are produced annually and is necessary, for example, for the automotive industry and the military. Additional discussion about rubber is provided where used for specific applications.

Many types of plastics are available for use in the design and manufacture of a product. These plastics generally fall into two main categories: thermoplastics and thermosets. Thermoplastics can be heated and formed by pressure, and their shapes can change when reheated. Thermosets are formed into shape by heat and pressure and cannot be reheated and changed into a different shape after curing. Most plastic products are made with thermoplastics because they are easy to make into shapes by heating, forming, and cooling. Thermoset plastics are the choice when the product is used in an application where heat exists, such as the distributor cap and other plastic parts found on or near the engine of your car. **Elastomers** are polymer-based materials that have elastic qualities not found in thermoplastics and thermosets. Elastomers are generally able to be stretched at least equal to their original length and return to their original length after stretching.

## Thermoplastics

Although there are thousands of different thermoplastic combinations, the following are some of the more commonly used alternatives. You may recognize some of them by their acronyms, such as PVC.

**Acetal:** Acetal is a rigid thermoplastic that has good corrosion resistance and machinability. Although it will burn, it is good in applications where friction, fatigue, toughness, and tensile strength are factors. Some applications include gears, bushings, bearings, and products that are exposed to chemicals or petroleum.

**Acrylic:** Acrylics are used when a transparent plastic is needed in for colorless or colored applications. Acrylics are commonly used in products that you see through or through which light passes because, in addition to transparency, they are scratch and abrasion resistant and hold up well in most weather conditions. Examples of use include windows, light fixtures, and lenses.

**Acrylic-styrene-acrylonitrile (ASA):** ASA has very good weatherability for use as siding, pools and spas, exterior car and marine parts, outdoor furniture, and garden equipment.

**Acrylonitrile-butadiene-styrene (ABS):** ABS is one of the most commonly used plastics because of its excellent impact strength, reasonable cost, and ease of processing. ABS also has good dimensional stability, temperature resistance above 212°F (100°C), and chemical and electrical resistance. ABS is commonly used in products that you see

daily, such as electronics enclosures, knobs, handles, and appliance parts.

**Cellulose:** There are five versions of cellulose: nitrate, acetate, butyrate, propionate, and ethyl cellulose.

- Nitrate is tough but very flammable, explosive, and difficult to process. It is commonly used to make products such as photo film, combs, brushes, and buttons.
- Acetate is not explosive but slightly flammable, not solvent resistant, and brittle with age. Acetate has the advantage of being transparent, can be made in bright colors, is tough, and is easy to process. It is often used for transparency film, magnetic tape, knobs, and sunglass frames.
- Butyrate is similar to acetate but is used in applications where moisture resistance is needed. Butyrate is used for exterior light fixtures, handles, film, and outside products.
- Propionate has good resistance to weathering, is tough and impact resistant, and has reduced brittleness with age. Propionate is used for flashlights, automotive parts, small electronics cases, and pens.
- Ethyl cellulose has very high shock resistance and durability at low temperatures but has poor weatherability.

**Fluoroplastics:** There are four types of fluoroplastics that have similar characteristics. These plastics are very resistant to chemicals, friction, and moisture. They have excellent dimensional stability for use as wire coating and insulation, nonstick surfaces, chemical containers, O-rings, and tubing.

**Ionomers:** Ionomers are very tough; resistant to abrasion, stress, cold, and electricity; and very transparent. They are commonly used for cold food containers, other packaging, and film.

**Liquid crystal polymers:** This plastic can be made very thin and has excellent temperature, chemical, and electrical resistance. Uses include cookware and electrical products.

**Methyl pentenes:** Methyl pentenes have excellent heat and electrical resistance and are very transparent. These plastics are used for items such as medical containers and products, cooking and cosmetic containers that require transparency, and pipe and tubing.

**Polyallomers:** This plastic is rigid with very high impact and stress fracture resistance at temperatures between -40° to 210°F (-40° to 99°C). Polyallomers are used when constant bending is required in the function of the material design.

**Polyamide (nylon):** Commonly called *nylon*, this plastic is tough, strong, and abrasion, heat, and friction resistant. Nylon is corrosion resistant to most chemicals but not as dimensionally stable as other plastics. Nylon is used for combs, brushes, tubing, gears, cams, and stocks.

**Polyarylate:** This material is impact, weather, electrical, and extremely fire resistant. Typical uses include electrical insulators, cookware, and other options where heat is an issue.

**Polycarbonates:** Excellent heat resistance, impact strength, dimensional stability, and transparency are positive characteristics of this plastic. In addition, this material does not stain or corrode but has moderate chemical resistance. Common uses include food containers, power tool housings, outside light fixtures, and appliance and cooking parts.

**Polyetheretherketone (PEEK):** PEEK has excellent qualities of heat, fire, abrasion, and fatigue resistance. Typical uses include high electrical components, aircraft parts, engine parts, and medical products.

**Polyethylene:** This plastic has excellent chemical resistance and has properties that make it good to use for slippery or nonstick surfaces. Polyethylene is a common plastic that is used for chemical, petroleum, and food containers; plastic bags; pipe fittings; and wire insulation.

**Polyimides:** This plastic has excellent impact strength, wear resistance, and very high heat resistance, but it is difficult to produce. Products made from this plastic include bearings, bushings, gears, piston rings, and valves.

**Polyphenylene oxide (PPO):** PPO has an extensive range of temperature use from 275° to 375°F (170° to 191°C), and it is fire retardant and chemical resistant. Applications include containers that require superheated steam, pipe and fittings, and electrical insulators.

**Polyphenylene sulfide (PPS):** PPS has the same characteristics as PPO but is easier to manufacture.

**Polypropylene:** This is an inexpensive plastic to produce and has many desirable properties, including heat, chemical, scratch, and moisture resistance. It is also resistant to continuous bending applications. Products include appliance parts, hinges, cabinets, and storage containers.

**Polystyrene:** This plastic is inexpensive and easy to manufacture, has excellent transparency, and is very rigid. However, it can be brittle and has poor impact, weather, and chemical resistance. Products include model kits, plastic glass, lenses, eating utensils, and containers.

**Polysulfones:** This material resists electricity and some chemicals, but it can be damaged by certain hydrocarbons. Although somewhat difficult to manufacture, it does have good structural applications at high temperatures and can be made in several colors. Common applications are hot-water products, pump impellers, and engine parts.

**Polyvinylchloride (PVC):** PVC is one of the most common products found for use as plastic pipes and vinyl house siding because of its ability to resist chemicals and weather.

**Thermoplastic polyesters:** There are two types of this plastic that exhibit strength and good electrical, stress, and chemical resistance. Common uses include electrical insulators, packaging, automobile parts, and cooking and chemical use products.

**Thermoplastic rubbers (TPR):** This resilient material has uses where tough, chemical-resistant plastic is needed. Uses include tires, toys, gaskets, and sports products.

## Thermosets

Thermoset plastics make up only about 15% of the plastics used because they are more expensive to produce, generally more brittle than thermoplastics, and cannot be remelted once they are molded into shape. However, their use is important in products that require a rigid and harder plastic than thermoplastic materials and in applications where heat could melt thermoplastics. The following list provides information about common thermoset plastics.

**Alkyds:** These plastics can be used in molding processes, but they are generally used as paint bases.

**Melamine formaldehyde:** This is a rigid thermoset plastic that is easily molded, economical, nontoxic, tough, and abrasion and temperature resistant. Common uses include electrical devices, surface laminates, plastic dishes, cookware, and containers.

**Phenolics:** The use of this material dates back to the late 1800s. This plastic is hard and rigid, has good compression strength, is tough, and does not absorb moisture—but it is brittle. Phenolic plastics are commonly used for the manufacture of electrical switches and insulators, electronics circuit boards, distributor caps, and binding material and adhesive.

**Unsaturated polyesters:** It is common to use this plastic for reinforced composites, also known as reinforced thermoset plastics (RTP). Typical uses are for boat and recreational vehicle construction, automobiles, fishing rods, tanks, and other structural products.

**Urea formaldehyde:** These plastics are used for many of the same applications as the previously described plastics, but they do not hold up to sunlight exposure. Common uses are for construction adhesives.

## Elastomers

Elastomers are types of polymers that are elastic, much like rubber. Elastomers are also referred to as *synthetic rubbers*. Synthetic rubbers produce almost twice as many products as natural rubber. **Natural rubber** is a material that starts as the sap from some trees. Natural rubber and many synthetic rubbers are processed by combining with adhesives and using a process called **vulcanization**, which is the heating of the material in a steel mold to form a desired shape. The following provides you with information about the most commonly used elastomers.

**Butyl rubber:** This material has a low air-penetration ability and very good resistance to ozone and aging but has poor petroleum resistance. Common uses include tire tubes and puncture-proof tire liners.

**Chloroprene rubber (Neoprene):** The trade-named product Neoprene was the first commercial synthetic rubber. This material has better weather, sunlight, and petroleum resistance than natural rubber. It is also very flame resistant but

does not resist electricity. Common uses include automotive hoses and other products where heat is found, gaskets, seals, and conveyor belts.

**Chlorosulfonated polyethylene (CSM):** CSM has excellent chemical, weather, heat, electrical, and abrasion resistance. It is typically used in chemical tank liners and electrical resistors.

**Epichlorohydrin rubber (ECO):** This material has great petroleum resistance at very low temperatures. For this reason, it is used in cold-weather applications such as snow-handling equipment and vehicles.

**Ethylene propylene rubber (EPM) and ethylene propylene diene monomer (EPDM):** This family of materials has excellent weather, electrical, aging, and good heat resistance. These materials are used for weather stripping, wire insulation, conveyor belts, and many outdoor products.

**Fluoroelastomers (FPM):** FPM materials have excellent chemical and solvent resistance up to 400°F (204°C). FPM is expensive to produce, so it is used only when its positive characteristics are needed.

**Nitrile rubber:** This material resists swelling when immersed in petroleum. Nitrile rubber is used for any application involving fuels and hydraulic fluid, such as hoses, gaskets, O-rings, and shoe soles.

**Polyacrylic rubber (ABR):** This material is able to resist hot oils and solvents. ABR is commonly used in situations such as transmission seals, where it is submerged in oil.

**Polybutadiene:** This material has qualities that are similar to those of natural rubber. It is commonly mixed with other rubbers to improve tear resistance.

**Polyisoprene:** This material was developed during World War II to help with a shortage of natural rubber, and it has the same chemical structure as natural rubber. However, this synthetic is more expensive to produce.

**Polysulfide rubber:** The advantage of this rubber is that it is petroleum, solvent, gas, moisture, weather, and age resistant. The disadvantage is that it is low in tensile strength, resilience, and tear resistance. Applications include caulking and putty, sealants, and castings.

**Polyurethane:** This material has the ability to act like rubber or hard plastic. Because of the combined rubber and hard characteristics, products include rollers, wear pads, furniture, and springs. In addition to these products, polyurethane is used to make foam insulation and floor coverings.

**Silicones:** This material has a wide range of makeup from liquid to solid. Liquid and semi liquid forms are used for lubricants. Harder forms are used where nonstick surfaces are required.

**Styrene butadiene rubber (SBR):** SBR is very economical to produce and is heavily used for tires, hoses, belts, and mounts.

**Thermoplastic elastomers (TPE):** The other elastomers typically require the expensive vulcanization process for

production. TPE, however, is able to be processed with injection molding just like other thermoplastics, and any scraps can be reused. There are different TPEs, and they are generally less flexible than other types of rubber.

## PLASTIC RESIN IDENTIFICATION CODES

The following is taken in part from an American Chemistry Council (ACC) ([www.americanchemistry.com](http://www.americanchemistry.com)) publication.

On the bottom of any plastic container is a number with arrows around it. These numbers are called **plastic resin identification codes**, and they indicate the type of plastic that an item is made from. These numbers are intended to help consumers know whether and how to recycle various plastic products and packages.

In 1988, the plastics industry, through the Society of the Plastics Industry, Inc. (SPI) ([www.plasticsindustry.org](http://www.plasticsindustry.org)), introduced its voluntary resin identification coding system. A growing number of communities were implementing recycling programs in an effort to decrease the volume of waste subject to rising tipping fees at landfills. In some cases, test programs were driven by state-level recycling mandates. The code system was developed to meet recyclers' needs while providing manufacturers a consistent, uniform system that could be applied nationwide. Municipal recycling programs traditionally have targeted packaging—primarily bottles and containers—and the resin coding system offered a means of identifying the resin content of bottles and containers commonly found in the residential waste stream. Recycling firms have varying standards for the plastics they accept. Some firms require that the plastics be sorted by type and separated from other recyclables, and some specify that mixed plastics are acceptable if they are separated from other recyclables, and others accept all material mixed.



### Plastic Resin Identification Codes

For a chart showing the letters and arrow symbols for different resin identification codes, go to the Student CD, select **Supplemental Material, Chapter 4**, and then **Plastic Resin Identification Codes**.

## PLASTICS MATERIAL SELECTION APPLICATIONS

The following is taken in part from the American Chemistry Council (ACC) Web site ([www.americanchemistry.com](http://www.americanchemistry.com)).

### Automotive Industry

In automotive design, plastics have contributed to a multitude of innovations in safety, performance, and fuel efficiency. From bumper to bumper, plastics are helping to drive



advancements in fuel efficiency, safety, and design in just about every mode of transportation. Plastics make up more than 50% of the volume of material in today's vehicles. Modern plastics are making cars stronger, safer, and more fuel efficient. The following are examples of plastics used in the automotive industry:

Seat belts are made from durable strands of polyester fiber.

Airbags are commonly made from high-strength nylon fabric.

Child safety seats are made possible by numerous advancements in polymer science.

Another priority in automotive design is weight reduction, a key driver in boosting fuel efficiency, reducing emissions, and lowering costs for motorists. Many plastic components can weigh 50% less than similar components made from other materials. Today's average light vehicle contains 332 pounds of plastics and composites, 8.3% by weight.

Plastics deliver the engineering and styling qualities that innovation and high performance demand. In exterior automobile applications, from bumper to bumper, plastics are lightweight and give designers the freedom to create innovative concepts that often would otherwise be impractical or virtually impossible. Plastics also resist dents, dings, stone chips,

## GREEN TECHNOLOGY APPLICATION

### THE USE OF PLASTIC AS A SUSTAINABLE PRODUCT

The ACC provides the following information outlining the characteristics of plastics as a sustainable material for use in the automotive industry, electronics, and packaging.

#### Plastics in the Automotive Industry

When weight savings are important, especially for improved fuel economy and lower vehicle emissions, plastics are often considered great materials. Automotive components designed in plastic and plastic-metal hybrids have achieved significant weight savings over some conventional designs. As the use of plastics in vehicle manufacturing increases, lightweight design techniques—the integration of plastics and polymer composites into vehicle design where some other materials have been traditionally used—can benefit performance and energy savings. Many plastic components can weigh 50% less than similar components made from other materials.

#### Plastics in the Electronics Industry

The ACC plastics division helps promote sound plastics recycling and recovery from electronic equipment and products by sponsoring research-and-development projects, publishing new information, and supporting technology-transfer initiatives. The organization is committed to working with stakeholders throughout the plastics and electronics supply groups to advance responsible and cost-effective plastic recycling from electronic equipment and products.

#### Plastics in the Packaging Industry

Plastic is used in packaging for the following reasons:

- Reduce material use and weight.
- Maintain freshness.

- Reduce breakage.
- Reduce transportation costs through lightweighting.
- Economical.

Plastics also can have superior environmental attributes to alternatives by reducing energy use by 26% and greenhouse gas emissions by 56% across variety of applications. Plastics help keep food fresh, reducing waste and protecting products from farms to grocery shelves to kitchen tables. Protecting the safety and integrity of the product are among the important aspects of sustainable packaging. An example of using plastic as a sustainable resource, Kraft recently switched its classic Miracle Whip jar from glass to plastic. This change decreased fuel consumption by 87,000 gallons annually. The switch to plastic means fewer trucks on the road because six more pallets of product fit on each truckload. Another plastic innovation was achieved when Pepsi announced a new Aquafina water bottle (called the Eco-Fina) that uses 50% less material, resulting in a reduction of 75 million pounds annually. Plastics reduce transportation energy. Lighter plastic packaging can mean lighter loads and fewer trucks and railcars needed to ship the same amount of product.

#### Reusability of Plastics

Some plastic packaging applications, such as storage bins, sealable food containers, and refillable sports bottles and dispensers are designed to be reusable. The durability of plastic makes it a preferred material for reusable items. Plastic crates and pallets are used repeatedly and prized for their durability and ability to resist moisture and insect infestation. Other examples of plastic reusability are that 92% of consumers reuse plastic shopping bags and 50% of polystyrene loose fill is reused.

and corrosion. Plastics allow modular assembly practices for reduced production costs. In automobile interiors, plastics are a great material for creating comfortable, durable, and aesthetically pleasing interior components while enhancing occupant protection and reducing noise and vibration levels. Plastics are strong, durable, corrosion resistant, and able to withstand high temperatures in harsh engine environments for use in electrical, power train, fuel, chassis, and engine applications.

## Electronics Industry

From computers and cell phones to televisions and microwaves, durable, lightweight, and affordable plastics have helped revolutionize the electronics industry. Plastics deliver an incredible range of performance benefits. Their unique combination of performance properties inspires innovation on two fronts: (1) the development of new and better products and (2) the more efficient use of resources. Plastics are essential to advances in weight reduction and miniaturization in many electronic products, so less material is used in production. In addition, plastics can be engineered to meet very specific performance requirements, often helping to achieve greater energy efficiency over the course of a product's life.

## MATERIAL SELECTION

The previous content describes many materials. Basic material selection applications were described for the use of common steels. The following provides additional general material selection guidelines. The materials presented are commonly used in the design and manufacture of products, but they are only an introduction to a vast number of material combinations available in industry. Material selection can be made during any stage of a **product life cycle**, but the best time to make material selection is during the initial design of a product or when the product is being redesigned.

*Product life cycle* refers to the complete life of a product, which includes these stages: idea, planning and development, introduction to the marketplace, sales buildup, maximum sales, declining sales, and withdrawal from the marketplace. Product life cycle lengths vary, depending on the type of product, the intended replacement rate, and other factors. Some products are designed and manufactured to last a long time, and some are purposely designed to last a short time. Normally, material selection is made at times other than initial design or redesign only if failures require the original material to be reconsidered. Material selection after the initial design and manufacturing can be very costly and should be avoided.

Proper material selection requires knowledge of material properties, material characteristics, material cost, material availability, manufacturing processes and costs, part geometry, external and internal forces applied to the parts and the assembly, product use, appearance, environmental considerations, and **sustainability**. Sustainability refers to something that can last or be maintained for long periods of time without damaging the environment or depleting resources.

## Selection of Aluminum and Its Alloys

Material selection is greatly influenced by the specific material characteristics. The following provides some of the characteristics of aluminum and its alloys, which lead to their widespread application in nearly every segment of the economy. You can use the aluminum characteristics to help determine if this material is suitable for your product:

### Lightweight

Very few metals have a lower density than aluminum, and they are not in common usage. Iron and copper are roughly three times as dense, and titanium is more than 60% denser than aluminum.

### Good Formability

Aluminum can be fabricated or shaped by just about every known method; as a result, it is available in a wide variety of forms.

### Wide Range of Mechanical Properties

Aluminum can be used as a low-strength, highly ductile material or, through alloying, as a material with a tensile strength approaching 100,000 psi.

### High Strength-to-Weight Ratio

Because of the combination of low density and high tensile strength, some aluminum alloys possess superior strength-to-weight ratios that are equal to or surpassed only by highly alloyed and strengthened steels and titanium.

### Good Low-Temperature Properties

Aluminum does not become brittle at very low temperatures. Mechanical properties of most aluminum alloys actually improve with decreasing temperature.

### Good Weatherability and General Corrosion Resistance

Aluminum does not rust away in the atmosphere and usually requires no surface protection. It is highly resistant to attack from a number of chemicals.

### High Electrical and Thermal Conductivity

Based on weight, aluminum conducts electricity and heat better than any other material except sodium, which can only be used under very special conditions. On a volume basis, only copper, silver, and gold are better conductors.

### High Reflectivity

Normally, aluminum reflects 80% of white light, and this value can be increased with special processing.

**Finishability**

Aluminum is unique among the architectural metals in respect to the variety of finishes in use.

**Recyclability**

Aluminum can be recycled repeatedly without reduction in the quality or value of the metal. Recycling saves approximately 95% of the energy required for the production of primary metal and reduces by 95% the environmental impact on water and air quality.

**Examples of Aluminum Numbering Applications and Material**

The following is a sample of general aluminum material selection applications based on use and related to the most commonly used aluminum alloy numbering system.

Alloy	Characteristics	Common Uses
1050/1200	Good formability, weldability, and corrosion resistance	Food and chemical industry
2014A	Heat-treatable, high strength Nonweldable, poor corrosion resistance	Airframes
3103/3003	Not heat-treatable	Vehicle paneling, structures exposed to marine atmosphere, mine cages
5251/5052	Medium strength work-hardening alloy Good weldability, formability, and corrosion resistance	
5454	Not heat-treatable Used at temperatures from 65°C to 200°C Good weldability and corrosion resistance	Pressure vessels and road tankers Transport of ammonium nitrate, petroleum Chemical plants
5083/5182	Not heat-treatable Good weldability and corrosion resistance Very resistant to seawater, industrial atmosphere	A superior alloy for cryogenic use (in annealed condition), pressure vessels, and road-transport applications below 65°C, ship-building structure in general
6063	Heat-treatable, medium strength alloy Good weldability and corrosion resistance	Used for complex profiles, architectural extrusions, window frames, irrigation pipes

6061/6082	Heat-treatable, medium strength alloy Good weldability and corrosion resistance	Stressed structural members, bridges, cranes, roof trusses, beer barrels
6005A	Heat-treatable Properties very similar to 6082 Preferable as air quenchable, with fewer distortion problems	Thin-walled, wide extrusions
7020	Heat-treatable Age hardens naturally, therefore will recover properties in heat-affected zone after welding Susceptible to stress corrosion Good ballistic-deterrent properties	Armored vehicles, military bridges, motor cycle, and bicycle frames
7075	Heat-treatable, very high strength Nonweldable, poor corrosion resistance	Airframes

**Examples of SAE Steel Numbering Applications**

Examples of SAE steel numbering applications for use in the material selection of steel were provided earlier in this chapter (refer to pages 124–126). This content provides a small sample of general steel material selection applications based on use and related to the SAE numbering system.

**Machinery's Handbook**

The *Machinery's Handbook* published by the Industrial Press, Inc. is one of the most valuable references available for use in your education and on the job in the manufacturing design and drafting industry. The *Machinery's Handbook* contains detailed information related to mathematics; mechanics; strength of materials; properties, treatment and testing of materials; plastics; dimensioning, gaging, and measuring; tooling and toolmaking; machining operations; manufacturing processes; fasteners and threads; gears, splines, and cams; bearings; and other machine elements. Useful examples include the tables containing general applications of SAE steels. These tables provide the specific application and the steel recommended for the application. Another often referenced feature for the drafter are the tables for unified screw thread selection. All standard series and selected combinations are given with detailed information. Detailed information is also provided to help you with fastener selection of inch and metric machine screws, cap screws, bolts, nuts, washers, and set screws to name a few.

## MANUFACTURING MATERIALS

CADD offers powerful tools that allow you to identify and test the material assigned to a product. CADD manufacturing material applications vary, depending on the CADD format, software, product requirements, and company practices. A dimensioned 2-D drawing typically includes a note that specifies the material assigned to a product. The drawing can also list values such as weight, usually calculated manually or with the aid of 2-D CADD tools. A 3-D surface model can display a representation of material on surfaces, which is typically only useful for presentation and visualization. A 3-D solid model is the most useful CADD format for presenting, testing, and analyzing a design, and it is the focus of the following information.

Solid modeling software usually allows you to assign a material to a model that closely replicates the material used to manufacture the product. For example, if a part is made from Nylon 6,6, which is a common thermoplastic nylon patented by DuPont, you are able to select Nylon 6,6 from a list of available materials or create a custom Nylon 6,6 material to apply to the model. The result is a solid model that acts as a digital prototype of a product. The material characteristics and amount of information stored in a model vary, depending on the software program. Most solid modeling applications allow you to apply materials that use specific colors and textures that closely match the actual look of a material, such as Nylon 6,6. You may also have the option of adjusting color, lighting, and texture characteristics to imitate the true look of the selected material. In addition, often when you select a material in the modeling environment, the material name and corresponding properties are

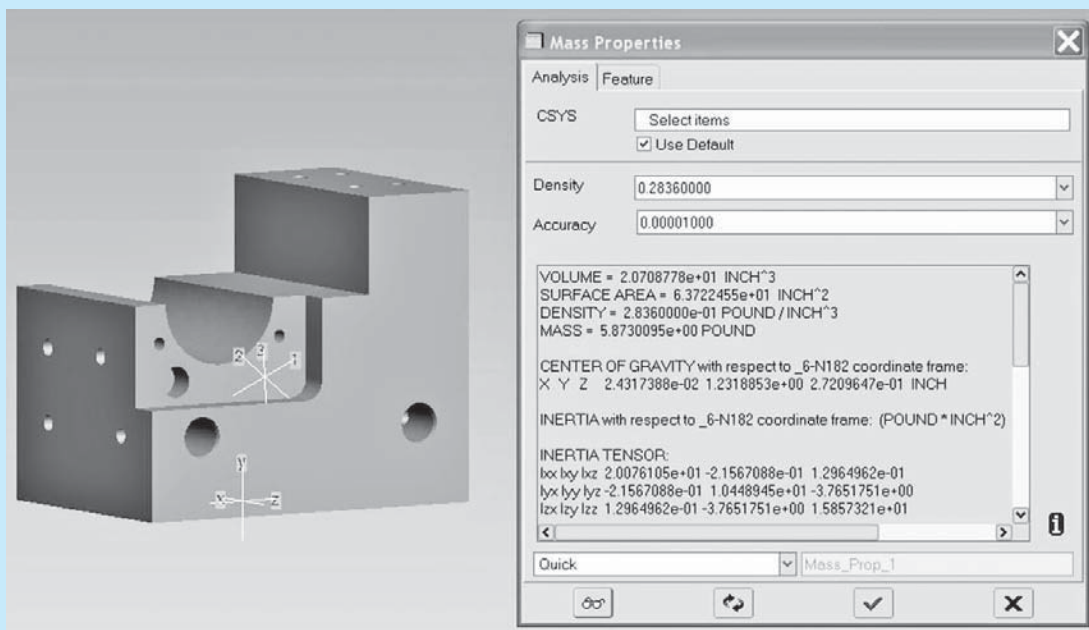
parametrically available for use in other applications such as parts lists, bills of materials, and notes on a drawing.

### Presentation and Visualization

Assigning a material to a solid model generally only affects the form, fit, and function of a component when you subject the model to testing and analysis. If a product does not require testing and analysis, assigning a material, or often only a color that replicates a material, to a model is only necessary for presentation and visualization. Designers typically begin a design with a specific material in mind. Therefore, often especially early in the design process, designers create models using a color that represents the material. This allows all members of a design team who view the models to identify which components are a form of metal, for example, and which components are a form of plastic.

### Testing and Analysis

Assigning a material to a solid model becomes most important when testing and analyzing the design. In some cases, the program used to analyze the model, especially finite element analysis (FEA) software, is different from the software used to develop the model. The analysis software often includes its own set of materials and may not recognize the material used in the original modeling program. As a result, choosing a material before analysis may be premature. Figure 4.3 shows an example of an analysis performed on the solid model of a production tooling component. The model is assigned a carbon steel material. The software uses the geometry of the model and material specifications to list mass properties.



**FIGURE 4.3** A solid part model assigned a carbon steel material and analyzed to explore mass properties.

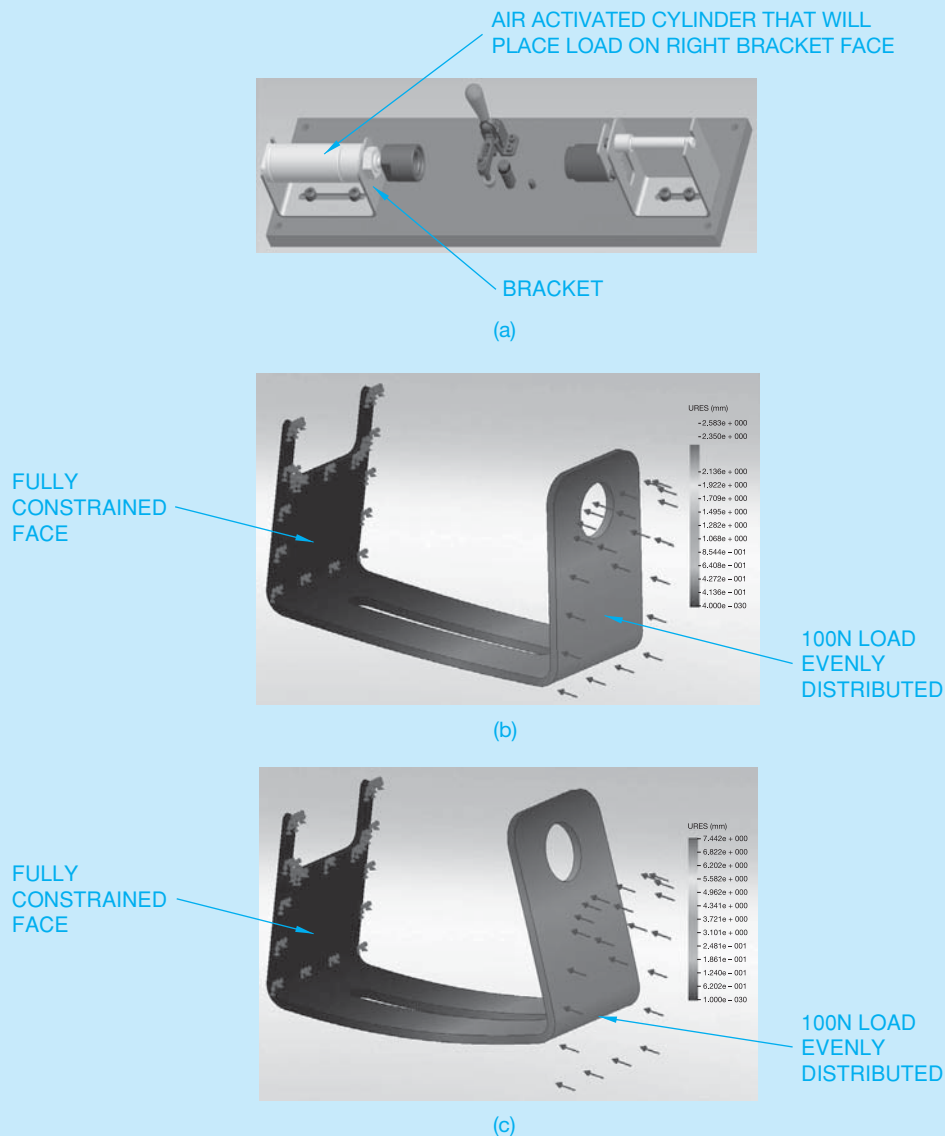
(Continued)

Often the material style includes or references color and texture settings to display a representation of the material. However, the main purpose of the material is to define physical properties. Depending on the product, the most useful physical and inertial properties provided during model analysis include mass properties to calculate volume and mass, density, hardness, electrical properties, yield strength, bendability, and ultimate tensile strength.

Designers often apply different materials to a model to explore how the model reacts. This is especially true for brackets, clamps, supports, and fixtures. Any component affected by force, pressure, or other factors, such as high engine vibration, is tested using different materials to identify the best performance to meet the functional requirements of the product. Weight is also a common factor that influences

material selection. For example, testing a model can show if a company can meet engineering specifications using lighter-weight aluminum or plastic rather than heavier steel.

Figure 4.4a shows a solid model of a production fixture with a bracket that will be analyzed for performance under load using different materials. The original material assigned to the bracket is stainless steel (SAE 316). Figure 4.4b shows the results of FEA using stainless steel. The design performs adequately, but the engineers desire to reduce the weight of the bracket. The engineers assign aluminum (6061-T6) to model and perform another FEA (see Figure 4.4c). The aluminum bracket does not perform well enough for manufacturing. The engineers continue testing the model using materials and eventually decide to use a tool steel (UNS 641400).



**FIGURE 4.4** An example of assigning different material to a solid part model to explore design performance under load. (a) Solid model of a production fixture with a bracket. (b) Results of FEA using stainless steel. (c) Results of FEA using aluminum.

Courtesy John Walters, BSME Synerject Principal Engineer, Synerject North America—Newport News, Virginia

## MANUFACTURING PROCESSES

Casting, forging, and machining processes are used extensively in the manufacturing industry. It is a good idea for the entry-level drafter or pre-engineer to be generally familiar with types of casting, forging, and machining processes and to know how to prepare related drawings. Any number of process methods can be used by industry. For this reason, it is best for the beginning drafting technician to remain flexible and adapt to the standards and techniques used by the specific company. It is common for a drafter who becomes familiar with company products, processes, and design goals to have the opportunity to become a designer and begin producing designs.

### Castings

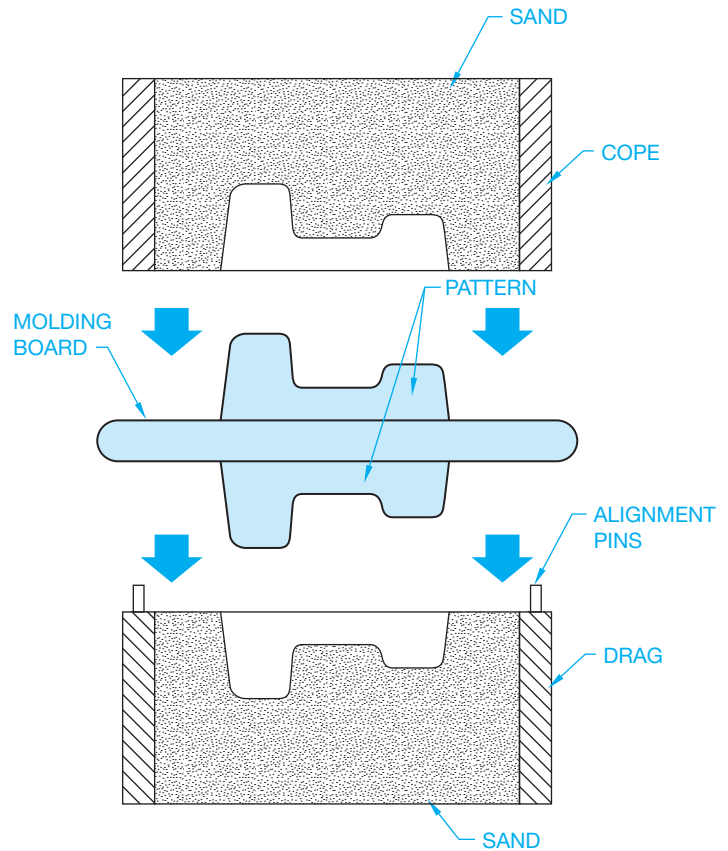
**Castings** are the result of a process called *foundry*. **Foundry** (or *casting*, as the process is commonly called) is the pouring of molten metal into a hollow or wax-filled mold. The mold is made in the shape of the desired casting. Several casting methods are used in industry. The results of some of the processes are castings that are made to very close tolerances and with smooth finished surfaces. In the simplest terms, castings are made in three separate steps:

1. A pattern is constructed that is the same shape as the desired finished product.
2. Using the pattern as a guide, a mold is made by packing sand or other material around the pattern.
3. When the pattern is removed from the mold, molten metal is poured into the hollow cavity. After the molten metal solidifies, the surrounding material is removed and the casting is ready for cleanup or machining operations.

### Sand Casting

**Sand casting** is the most commonly used method of making castings. There are two general types of sand castings: green sand and dry sand molding. **Green sand** is specially refined sand that is mixed with specific moisture, clay, and resin, which work as binding agents during the molding and pouring procedures. New sand is light brown in color: the term “green sand” refers to the moisture content. In the **dry sand** molding process, the sand does not have any moisture content. The sand is bonded together with specially formulated resins. The result of the green sand or the dry sand molds is the same.

Sand castings are made by pounding or pressing the sand around a **split pattern**. The first or lower half of the pattern is placed upside down on a molding board, and sand is then pounded or compressed around the pattern in a box called a **drag**. The drag is then turned over, and the second or upper half of the pattern is formed when another box, called a **cope**, is packed with sand and joined to the drag. A fine powder is used as a parting agent between the cope and drag at the parting line, or the separating joint between the two parts of the pattern or mold. The entire box, made up of the cope and drag, is referred to as a **flask** (see Figure 4.5).

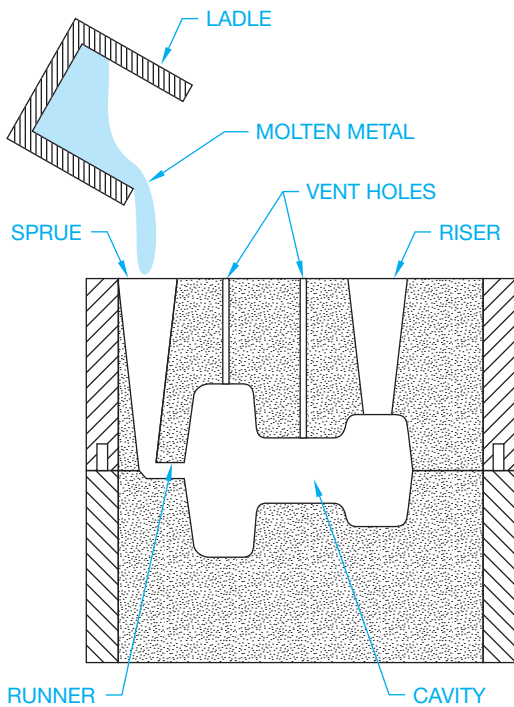


**FIGURE 4.5** Components of the sand casting process. © Cengage Learning 2012

Before the molten metal can be poured into the cavity, a passageway for the metal must be made. The passageway is called a **runner** and **sprue**. The location and design of the sprue and runner are important to allow for a rapid and continuous flow of metal. In addition, **vent holes** are established to let gases, impurities, and metal escape from the cavity. Finally, a riser (or group of risers) is used, depending on the size of the casting, to allow the excess metal to evacuate from the mold and, more importantly, to help reduce shrinking and incomplete filling of the casting (see Figure 4.6). After the casting has solidified and cooled, the filled risers, vent holes, and runners are removed.

### Cores

A **core** is a hole or cavity that is desired in the casting to help reduce the amount of material removed later or to establish a wall thickness. Cores are made either from clean sand mixed with binders such as resin and baked in an oven for hardening or from ceramic products when a more refined surface finish is required. When the pattern is made, a **core print** is created as a place for positioning the core in the mold. After the mold is made, the core is then placed in position in the mold at the core print. The molten metal, when poured into the mold, flows around the core. After the metal has cooled, the casting is removed from the flask, and the core is cleaned out, usually by shaking or tumbling. Figure 4.7 shows cores in place.



© Cengage Learning 2012

FIGURE 4.6 Pouring molten metal into a sand casting mold.

fine detail. Certain considerations must be taken for supporting very large or long cores when placed in the mold. Usually in sand casting, cores require extra support when they are three times longer than the cross-sectional dimension. Depending on the casting method, the material, the machining required, and the quality, the core holes should be a specified dimension smaller than the desired product if the hole is to be machined to its final dimension. Cores in sand castings should be between .125 and .5 in. (3.2 to 12.7 mm) smaller than the finished size.

### Centrifugal Casting

Objects with circular or cylindrical shapes lend themselves to centrifugal casting. In this casting process, a mold is revolved very rapidly while molten metal is poured into the cavity. The molten metal is forced outward into the mold cavity by centrifugal forces. No cores are needed because the fast revolution holds the metal against the surface of the mold. This casting method is especially useful for casting cylindrical shapes such as tubing, pipes, and wheels (see Figure 4.8).

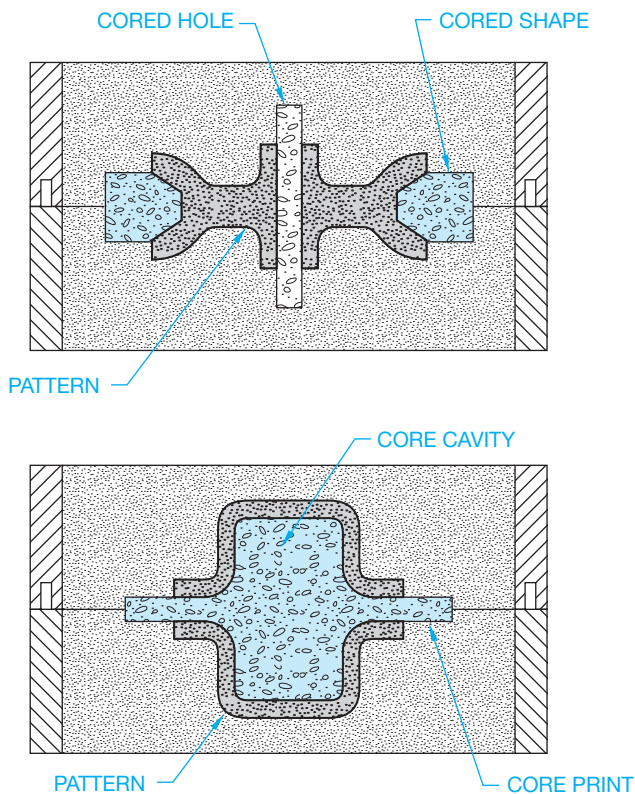


FIGURE 4.7 Cores in place. © Cengage Learning 2012

Cored features help reduce casting weight and save on machining costs. Cores used in sand casting should generally be more than 1 in. (25.4 mm) in cross section. Cores used in precision casting methods can have much closer tolerances and

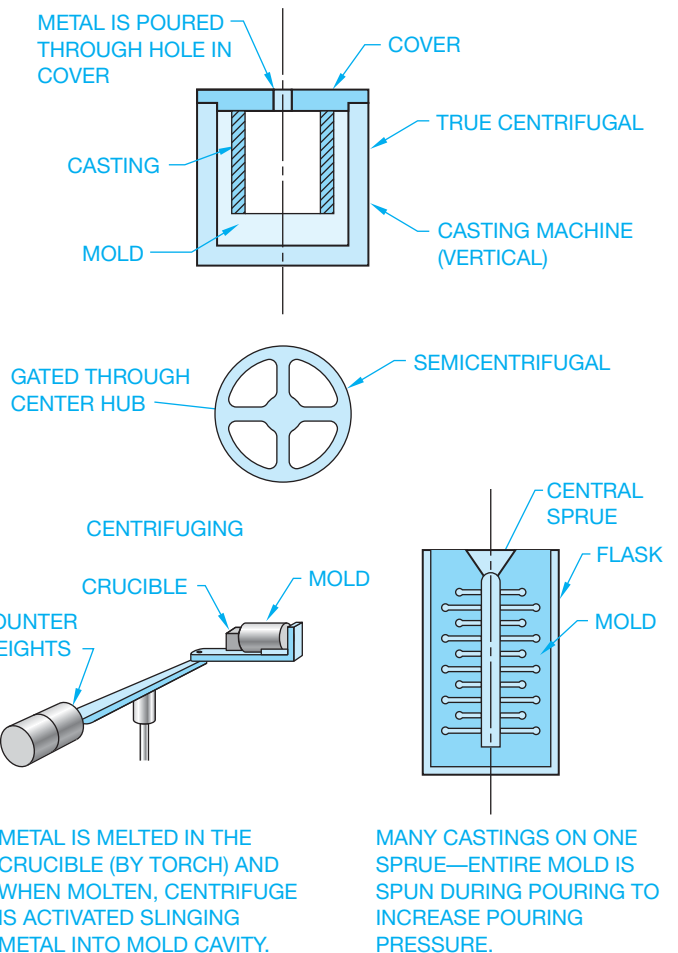


FIGURE 4.8 Centrifugal casting. © Cengage Learning 2012

HOW IT WORKS

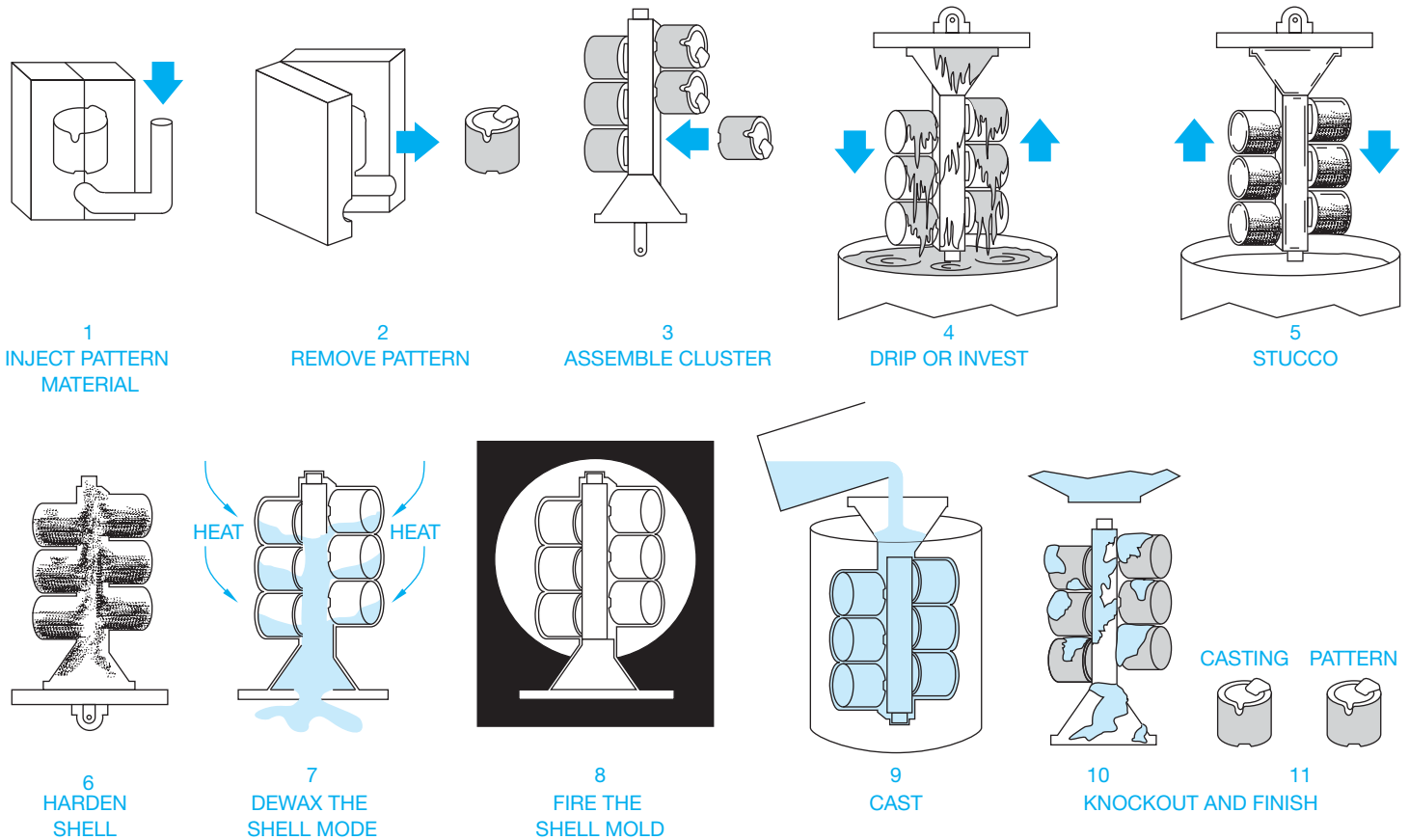


FIGURE 4.9 Investment casting process. Courtesy Precision Castparts Corporation

Die Casting

Some nonferrous metal castings are made using the **die casting** process. Zinc alloy metals are the most common, although brass, bronze, aluminum, and other nonferrous products are also made using this process. Die casting is the injection of molten metal into a steel or cast iron die under high pressure. The advantage of die casting over other methods, such as sand casting, is that castings can be produced quickly and economically on automated production equipment. When multiple dies are used, a number of parts can be cast in one operation. Another advantage of die casting is that high-quality precision parts can be cast with fine detail and a very smooth finish.

Permanent Casting

**Permanent casting** refers to a process in which the mold can be used many times. This type of casting is similar to sand casting in that molten metal is poured into a mold. It is also similar to die casting because the mold is made of cast iron or steel. The result of permanent casting is a product that has better finished qualities than can be gained by sand casting.

Investment Casting

**Investment casting** is one of the oldest casting methods. It was originally used in France to produce ornamental figures. The process used today is a result of the **cire perdue**, or **lost-wax**, casting technique that was originally used. The reason that investment casting is called lost-wax casting is that the pattern is made of wax. This wax pattern allows for the development of very close tolerances, fine detail, and precision castings. The wax pattern is coated with a ceramic paste. The shell is allowed to dry and then baked in an oven to allow the wax to melt and flow out—“lost,” as the name implies. The empty ceramic mold has a cavity that is the same shape as the precision wax pattern. This cavity is then filled with molten metal. When the metal solidifies, the shell is removed and the casting is complete. Generally, very little cleanup or finishing is required on investment castings (see Figure 4.9).

Forgings

**Forging** is a process of shaping malleable metals by hammering or pressing between dies that duplicate a desired shape. The forging process is shown in Figure 4.10. Forging can be accomplished on hot or cold materials. Cold forging is possible on



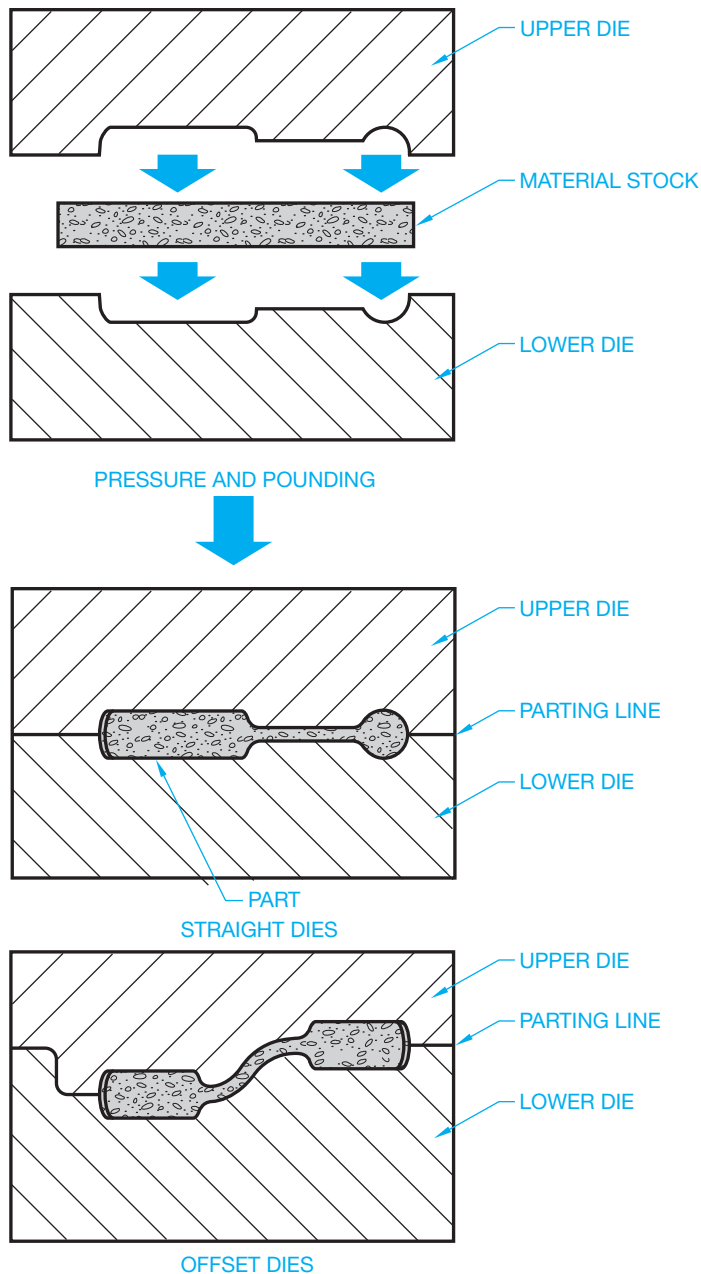


FIGURE 4.10 The forging process. © Cengage Learning 2012

certain materials or material thicknesses where hole punching or bending is the required result. Some soft, nonferrous materials can be forged into shape while cold. Ferrous materials such as iron and steel must be heated to a temperature that results in an orange-red or yellow color. This color is usually achieved between 1800° and 1950°F (982° and 1066°C).

Forging is used for a large variety of products and purposes. The advantage of forging over casting or machining operations is that the material is shaped into the desired form, retaining its original grain structure in the process. Forged metal is generally stronger and more ductile than cast metal and exhibits a greater resistance to fatigue and shock than machined parts. Notice in Figure 4.11 that the grain structure of the forged material remains parallel to the contour of the part, while the machined part cuts through the cross section of the material grain.

## Hand Forging

**Hand forging** is an ancient method of forming metals into desired shapes. The method of heating metal to a red color and then beating it into shape is called **smithing** or, more commonly, **blacksmithing**. Blacksmithing is used only in industry for finish work but is still used for horseshoeing and the manufacture of specialty ornamental products.

## Machine Forging

Types of machine forging include upset, swaging, bending, punching, cutting, and welding. **Upset forging** is a process of forming metal by pressing along the longitudinal dimension to decrease the length while increasing the width. For example, bar stock is upset forged by pressing dies together from the ends of the stock to establish the desired shape. **Swaging** is the forming of metal by using concave tools or dies that result in a reduction in material thickness. **Bending** is accomplished by forming metal between dies, changing it from flat stock to a desired contour. Bending sheet metal is a cold forging process in which the metal is bent in a machine called a **break**. **Punching** and **cutting** are performed when the die penetrates the material to create a hole of a desired shape and depth or to remove material by cutting away. In **forge welding**, metals are joined together under extreme pressure. Material that is welded in this manner is very strong. The resulting weld takes on the same characteristics as the metal before joining.

Mass-production forging methods allow for the rapid production of the high-quality products shown in Figure 4.12. In machine forging, the dies are arranged in sequence so that the finished forging is done in a series of steps. Complete shaping can take place after the material has been moved through several stages. Additional advantages of machine forging include:

- The part is formed uniformly throughout the length and width.
- The greater the pressure exerted on the material, the greater the improvement of the metallic properties.
- Fine grain structure is maintained to help increase the part's resistance to shock.
- A group of dies can be placed in the same press.

## Metal Stamping

**Stamping** is a process that produces sheet metal parts by the quick downward stroke of a ram die that is in the desired shape. The machine is called a **punch press**. The punch press can “punch” holes of different sizes and shapes, cut metal, or form a variety of shapes. Automobile parts such as fenders and other body panels are often produced using stamping. If the punch press is used to create holes, then the ram has a die in the shape of the desired hole or holes that pushes through the sheet metal. The punch press also can produce a detailed shape by pressing sheet metal between a die set, where the shape of the desired part is created between the die on the bed of the machine and the matching die on the ram. Stamping is generally done on cold sheet metal, as compared with forging that is done on hot metal that is often much thicker. The stamping

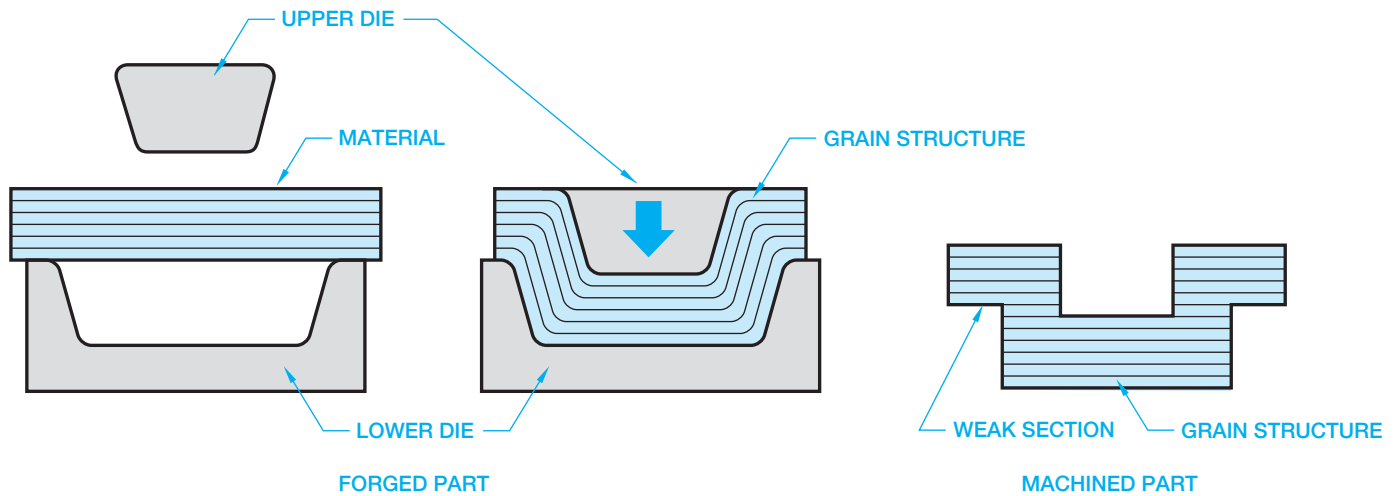


FIGURE 4.11 Forging compared to machining. © Cengage Learning 2012

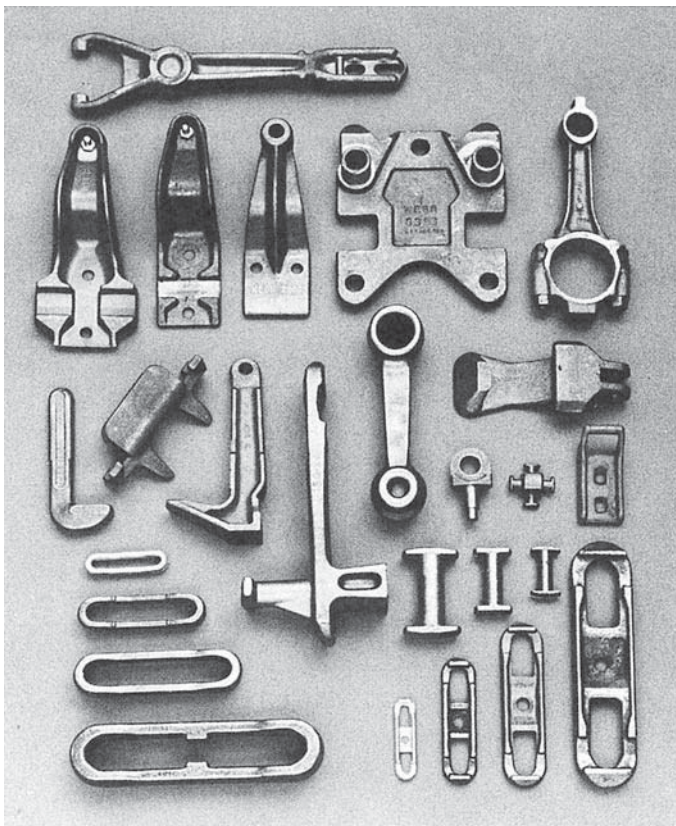


FIGURE 4.12 Forged products. Courtesy Jervis B. Webb Co.

process is useful in producing a large number of parts. The process can often fabricate thousands of parts per hour. This is a very important consideration for mass production.

### Hydroforming

**Hydroforming** is a process by which high-pressure hydraulic fluid is applied to ductile metals to form a specified shape. The metal, also called a *blank*, could be in the form of either a tube

or a sheet. The blank is inserted into a die, and fluid pressure is applied to the blank to deform the blank plastically into the desired shape of the die.

In tube hydroforming, an end stop is placed at one end of the hollow tube, while fluid pressure is applied through the other end. The tube expands to fill the die, which encloses the tube. In sheet metal hydroforming, the fluid pressure is applied to one side of the sheet, causing the sheet to conform to the shape of the die. Hydroforming produces components with higher strength-to-weight ratios and lower costs than metal stamping. Today, hydroforming is primarily used in the automobile industry to form parts such as engine cradles, chassis frames, and body panels.

### Powder Metallurgy (PM)

The **powder metallurgy (PM)** process takes metal-alloyed powders and feeds them into a die, where they are compacted under pressure to form the desired shape. The compacted metal is then removed from the die and heated at temperatures below the melting point of the metal. This heating process is referred to as **sintering**, and it forms a bond between the metal powder particles (discussed later in this chapter). Powder metallurgy processes can be a cost-effective alternative to casting, forging, and stamping. This type of manufacturing can produce thousands of quality, precision parts per hour.

### Metal Injection Molding (MIM)

**Metal injection molding (MIM)** is a powder metallurgy process that can produce very complex parts. This process injects a mixture of powder metal and a binder into a mold under pressure. The molded product is then sintered to create properties in the metal particles that are close to a casting.

## Powder Forging (PF)

**Powder forging (PF)** is a powder metallurgy process that places the formed metal particles in a closed die where pressure and heat are applied. This is similar to the forging process. This process produces precision products that have good impact resistance and fatigue strength.

## MACHINE PROCESSES

The concepts covered in this chapter serve as a basis for many of the dimensioning practices presented in Chapter 10, *Dimensioning and Tolerancing*. A general understanding of machining processes and the drawing representations of these processes is a prerequisite to dimensioning practices. Problem applications are provided in the following chapters because knowledge of dimensioning practice is important and necessary to be able to complete manufacturing drawings. **Machining** is a general term used to define the process of removing excess or unwanted material with machine tools for rough or finish turning, boring, drilling, milling, or other processes. Machining is used for the manufacture of almost all metal products and is used to create or complete some plastic products.

## Machine Tools

**Machine tools** are power-driven tools such as lathes, drills, mills, and other tools discussed in the following content. A **machinist** is a person who specializes in machining.

### Drilling Machine

The **drilling machine**, often referred to as a **drill press** (Figure 4.13), is commonly used to machine-drill holes. Drilling machines are also used to perform other operations such as reaming, boring, countersinking, counterboring, and tapping. During the drilling procedure, the material is held on a table while the drill or other tool is held in a revolving spindle over the material. When drilling begins, a power or hand-feed mechanism is used to bring the rotating drill in contact with the material. Mass-production drilling machines are designed with multiple spindles. Automatic drilling procedures are available on turret drills. These turret drills allow for automatic tool selection and spindle speed. Several operations can be performed in one setup—for example, drilling a hole to a given depth and tapping the hole with a specified thread.

### Grinding Machine

A **grinding machine** uses a rotating abrasive wheel rather than a cutting tool to remove material (see Figure 4.14). The **grinding** process is generally used when a smooth, accurate surface finish is required. Extremely smooth surface finishes can be achieved by honing or lapping. **Honing** is a fine abrasive process often used to establish a smooth finish inside cylinders. **Lapping** is the process of creating a very smooth surface finish using a soft metal impregnated with fine abrasives, or fine abrasives mixed in a coolant that floods over the part during the lapping process.

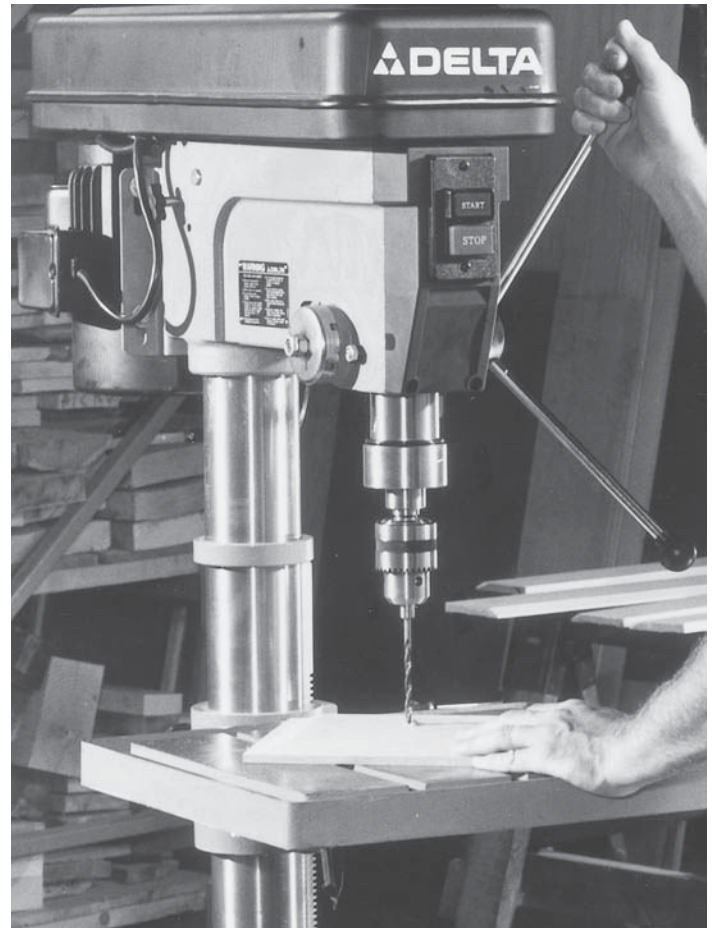


FIGURE 4.13 Drilling machine. Courtesy Delta International Machining Corporation

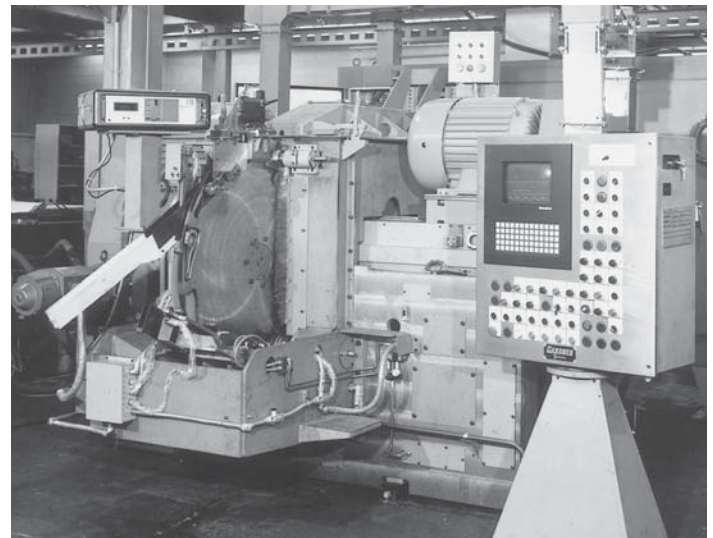


FIGURE 4.14 Grinding machine. Courtesy Litton Industrial Automation

### Lathe

One of the earliest machine tools, the **lathe** (Figure 4.15), is used to cut material by turning cylindrically shaped objects. The material to be turned is held between two rigid supports called **centers** or in a holding device called a **chuck** or **collet**, as shown

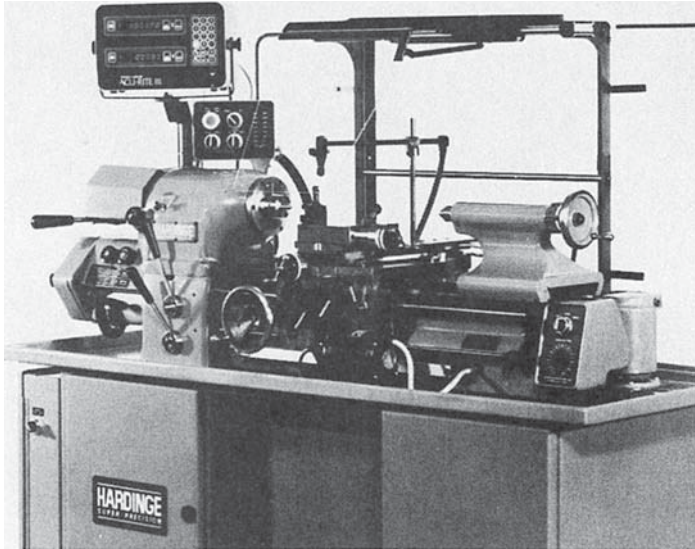


FIGURE 4.15 Lathe. Courtesy Harding Brothers, Inc.

The **turret** is used in mass-production manufacturing where one machine setup must perform several operations. A **turret lathe** is designed to carry several cutting tools in place of the lathe tailstock or on the lathe carriage. The operation of the turret provides the operator with an automatic selection of cutting tools at preestablished fabrication stages. Figure 4.17 shows an example of eight turret stations and the tooling used.

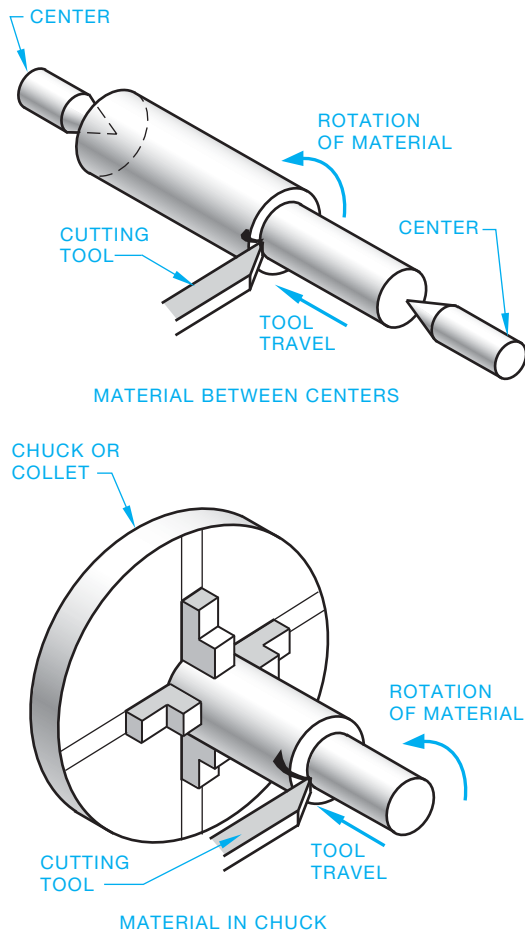
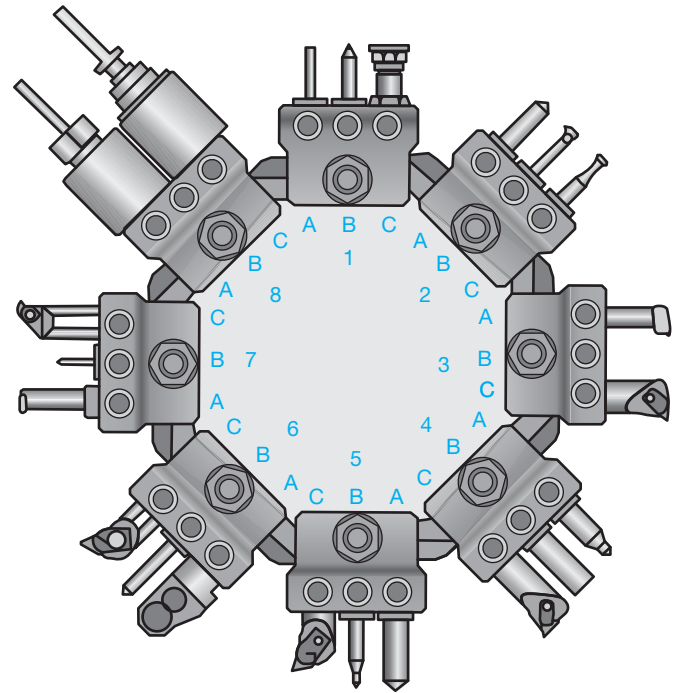


FIGURE 4.16 Holding material in a lathe. © Cengage Learning 2012

in Figure 4.16. The material is rotated on a **spindle** while a cutting tool is brought into contact with the material. A spindle is a rotating shaft. The cutting tool is supported by a tool holder on a carriage that slides along a bed as the lathe operation continues.



STATION	Model	TOOLING Description
1A		Drill with Bushing
1B		Center Drill with Bushing
1C	T20 -5/8	Adjustable Revolving Stock Stop
2A		Drill with Bushing
2B		Boring Bar with Bushing
2C		Threading Tool with Bushing
3A		Grooving Tool
3C		Insert Turning Tool
4A		Center Drill with Bushing
4B		Flat Bottom Drill with Bushing
4C		Insert Turning Tool
5A		Drill with Bushing
5B		Step Drill with Bushing
5C		Insert Turning Tool
6A	T8 -5/8	Knurling Tool
6B		Drill with Bushing
6C		Insert Turning Tool
7A		Grooving Tool
7B		Drill with Bushing
7C		Insert Threading Tool
8A	TT -5/8	"Collet Type" Releasing Tap Holder Tap Collet Tap
8C	TE -5/8 T19 -5/8	Tool Holder Extension Floating Reamer Holder Reamer with Bushing

FIGURE 4.17 A turret with eight tooling stations and the tools used at each station. Courtesy Toyota Machinery USA, Inc.

### Screw Machine

A **screw machine** is a type of lathe that is specialized for the automated mass production of small parts. Screw machines are used in manufacturing for high-volume, low-cost turned parts. Screw machines have been used in industry for more than 100 years. Originally, they were used to make screws and threaded parts. Today, screw machines are used for the high-volume manufacture of small turned parts, whether or not the parts have screw threads. Screw machines are fully automated and can have one or many spindles. On a single-spindle screw machine, long cylindrical rod stock is fed to the machine. As the stock is advanced, each part is turned to the desired specifications and cut off from the stock when finished. The process continues automatically and very quickly to the next part. On a multiple spindle machine, a long cylindrical bar of material is fed to each spindle at the same time. A common configuration is six spindles. The cage that holds these six bars of material indexes after each machining operation is complete. Each station can have multiple tools that machine material in an established sequence. The operation of these tools is similar to the function of a turret lathe.

### Milling Machine

The **milling machine** (Figure 4.18) is one of the most versatile machine tools. The milling machine uses a rotary cutting tool to remove material from the work. The two general types of milling machines are horizontal and vertical mills. The difference is in the position of the cutting tool, which can be mounted on either a horizontal or a vertical spindle. In the operation, the work is fastened to a table that is mechanically fed into the cutting tool, as shown in Figure 4.19. A large variety of milling cutters are available that influence the flexibility of operations and shapes that can be performed using the milling machine. Figure 4.20 shows a few of the milling cutters available. Figure 4.21 shows a series of milling cutters grouped together to perform a milling operation. **End milling cutters**, as shown in Figure 4.22, are designed to cut on the end and the sides of the cutting tool. Milling machines that

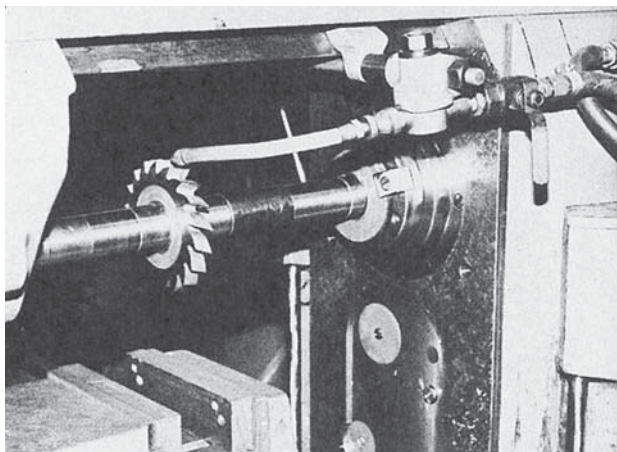
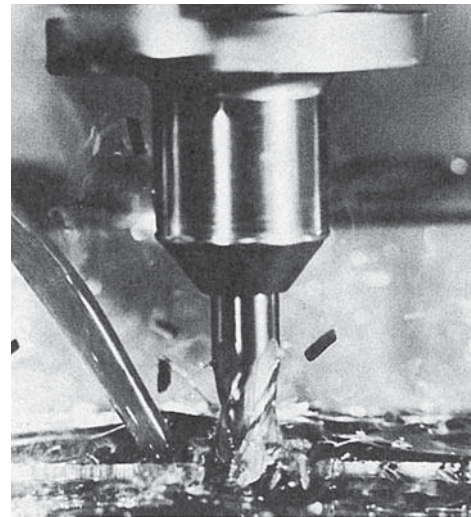


FIGURE 4.18 Close-up of a horizontal milling cutter.



Courtesy Greenfield Industries

FIGURE 4.19 Material removal with a vertical machine cutter.

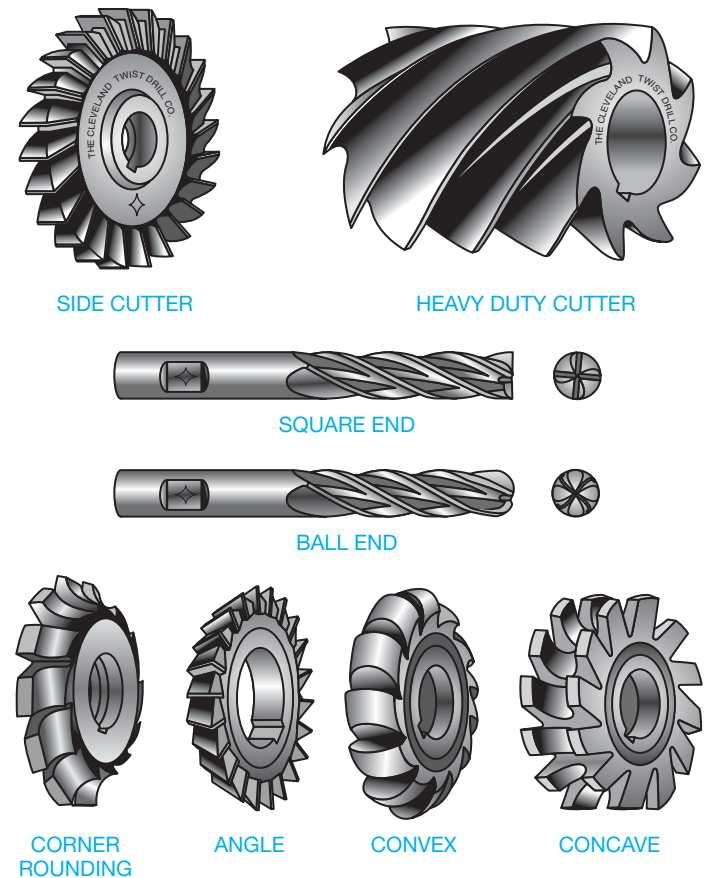
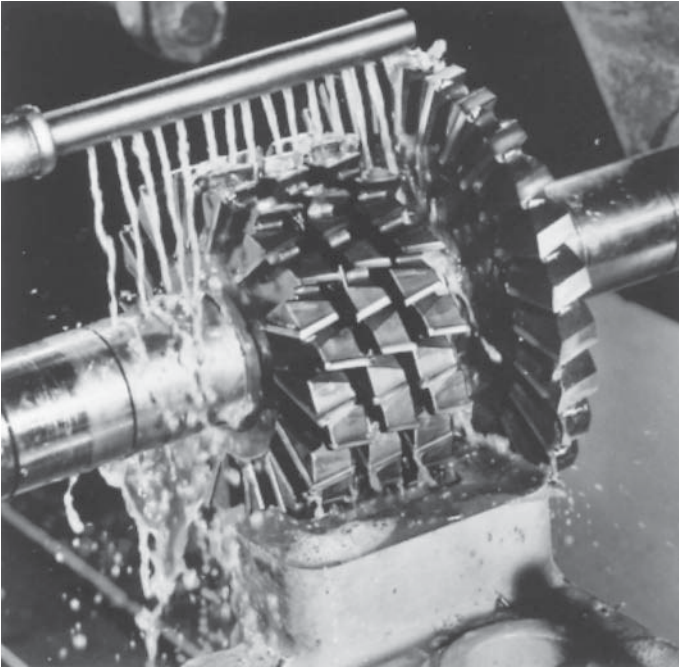


FIGURE 4.20 Milling cutters. Courtesy Greenfield Industries

are commonly used in high-production manufacturing often have two or more cutting heads that are available to perform multiple operations. The machine tables of standard horizontal or vertical milling machines move from left to right (*x*-axis), forward and backward (*y*-axis), and up and down (*z*-axis) as shown in Figure 4.23.

© Cengage Learning 2012



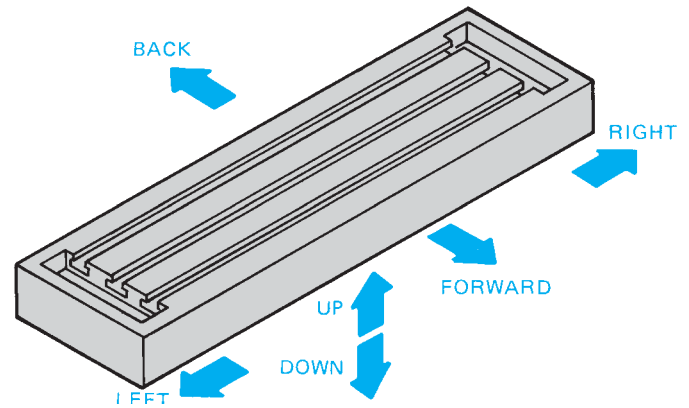
**FIGURE 4.21** Grouping horizontal milling cutter for a specific machining operation. *Courtesy Greenfield Industries*



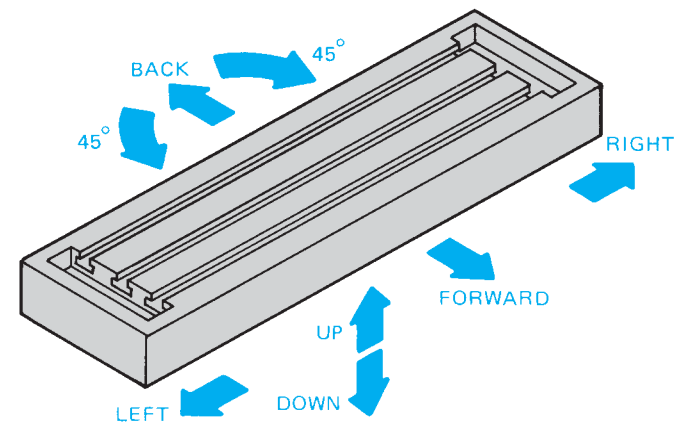
**FIGURE 4.22** End milling operation. *Courtesy Greenfield Industries*

### The Universal Milling Machine

Another type of milling machine known as the **universal milling machine** has table action that includes  $x$ -,  $y$ -, and  $z$ -axis movement plus angular rotation. The universal milling machine looks much the same as other milling machines but has the advantage of additional angular table movement as shown in Figure 4.24. This additional table movement allows the universal milling machine to produce machined features, such as spirals, that are not possible on conventional machines.



**FIGURE 4.23** Table movements on a standard milling machine. © Cengage Learning 2012



**FIGURE 4.24** Table movements on a universal milling machine. © Cengage Learning 2012

### Multiaxis Milling Machines

**Multiaxis milling machinings** are computer numerical controlled (CNC) machine tools that move in four or more directions, allowing the manufacture of complex parts with curved features. In addition to the  $x$ -,  $y$ -, and  $z$ -axis movement plus angular rotation of the universal milling machine, the multi-axis milling machine provides rotation around one or more axes. Multiaxis machines can remove material with milling cutters and are available with water jet or laser cutting. The movement of each axis is controlled either by moving the table where the workpiece is attached or by moving the tool around the workpiece. The configuration of axes can vary between machines, allowing the manufacturer to select machines for specific applications.

### Saw Machines

**Saw machines** can be used as cutoff tools to establish the length of material for further machining, or saw cutters can be used to perform certain machining operations such as cutting a narrow slot called a **kerf**.

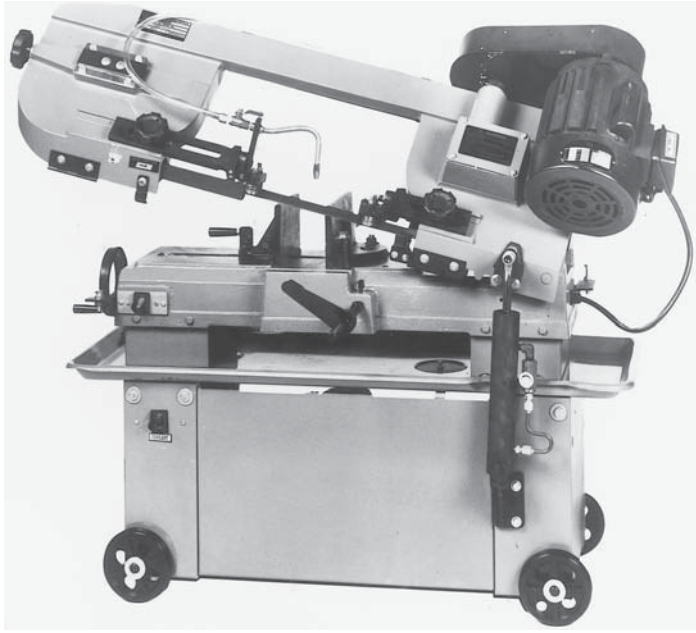


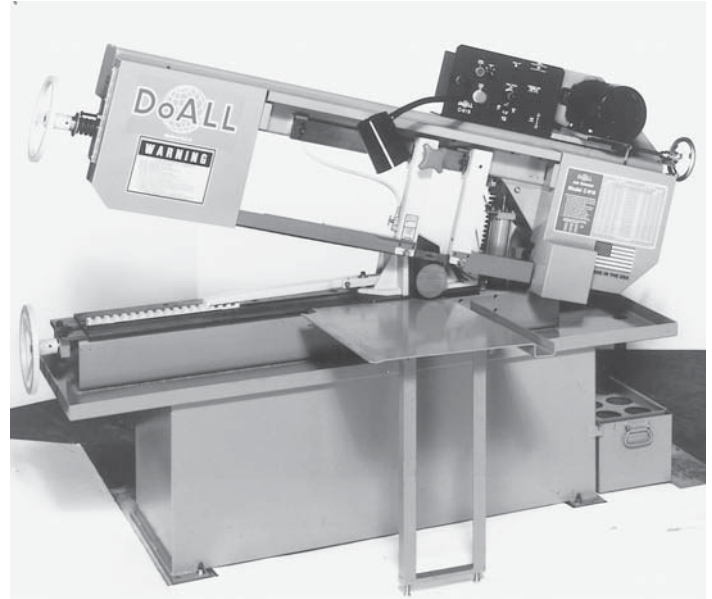
FIGURE 4.25 Power hacksaw. Courtesy JET Equipment and Tool

Two types of machines that function as cutoff units only are the **power hacksaw** and the **band saw**. These saws are used to cut a wide variety of materials. The hacksaw (Figure 4.25) operates using a back-and-forth motion. The fixed blade in the power hacksaw cuts material on the forward motion. The metal-cutting band saw is available in a vertical or horizontal design, as shown in Figure 4.26. This type of cutoff saw has a continuous band that runs either vertically or horizontally around turning wheels. Vertical band saws are also used to cut out irregular shapes.

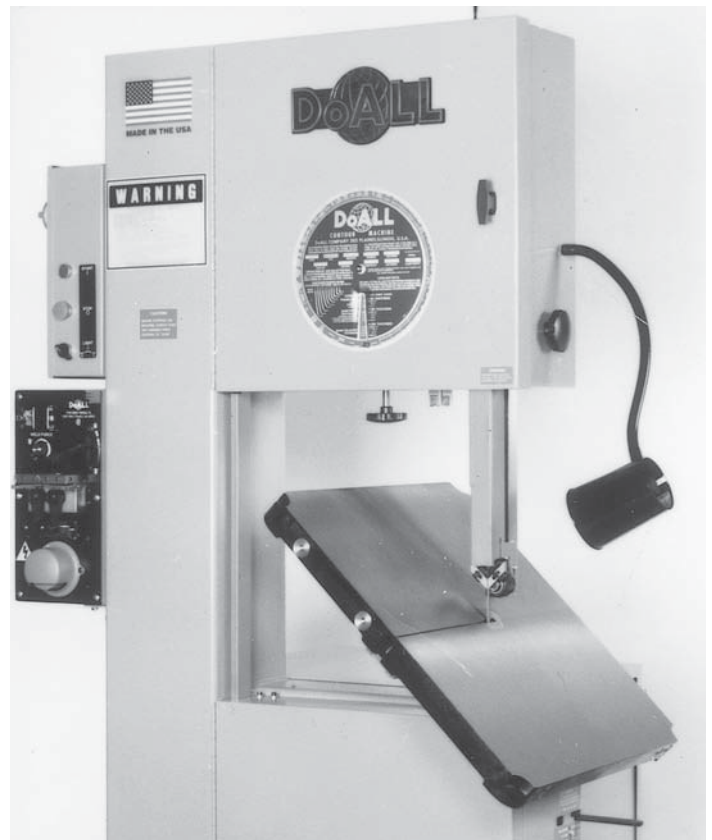
Saw machines are also made with circular abrasive or metal cutting wheels. The **abrasive saw** can be used for high-speed cutting where a narrow saw kerf is desirable or when very hard materials must be cut. One advantage of the abrasive saw is its ability to cut a variety of materials—from soft aluminum to case-hardened steels. Cutting a variety of metals on the band or the power hacksaw requires blade and speed changes. A disadvantage of the abrasive saw is the expense of abrasive discs. Many companies use this saw only when versatility is needed. The abrasive saw is usually found in the grinding room where abrasive particles can be contained, but it can also be used in the shop for general-purpose cutting. Metal-cutting saws with teeth, also known as **cold saws**, are used for precision cutoff operations, cutting saw kerfs, slitting metal, and other manufacturing uses. Figure 4.27 shows a circular saw blade.

## Water Jet Cutting

**Water jet cutting** is a cutting tool that uses a high-velocity stream of water combined with an abrasive substance to cut through various materials. Compressed fluid at 60,000 psi is forced through a



(a)



(b)

FIGURE 4.26 (a) Horizontal band saw. (b) Vertical band saw. Courtesy DoAll Co.

very small orifice, creating a thin stream of water traveling close to 600 miles per hour. This stream makes water jets capable of cutting through almost any material, including metals, glass, and stone. In general, water jets are used to cut materials with an average

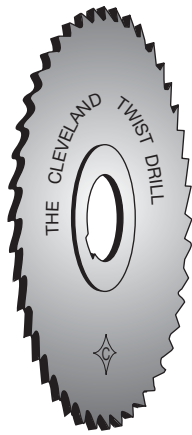


FIGURE 4.27 Circular blade saw. Courtesy Greenfield Industries

thickness of about 1 in. (25.4 mm), but they are capable of cutting through material as thick as 12 in. (305 mm) or more at slower cutting speeds. Water jets have many advantages over other cutting tools, which makes them very common in manufacturing. They are capable of holding fine tolerances of less than .003 in. (0.076 mm) with a cutting width of only .03 in. (0.76 mm). In addition, water jets do not produce a heat-affected zone within the material, which allows the material properties to remain unchanged.

### Shaper

The **shaper** is used primarily for the production of horizontal, vertical, or angular flat surfaces. Shapers are generally becoming out of date and are rapidly being replaced by milling machines. A big problem with the shaper in mass-production industry is that it is very slow and cuts only in one direction. One main advantage of the shaper is its ability to cut irregular shapes that cannot be conveniently reproduced on a milling machine or other machine tools. However, other more advanced multi-axis machine tools are now available that quickly and accurately cut irregular contours.

## Chemical Machining

**Chemical machining** uses chemicals to remove material accurately. The chemicals are placed on the material to be removed while other areas are protected. The amount of time the chemical remains on the surface determines the extent of material removal. This process, also known as *chemical milling*, is generally used in situations in which conventional machining operations are difficult. A similar method, referred to as *chemical blanking*, is used on thin material to remove unwanted thickness in certain areas while maintaining “foil”-thin material at the machined area. Material can be machined to within .0008 in. (0.002 mm) using this technique.

### Electrochemical Machining (ECM)

**Electrochemical machining (ECM)** is a process in which a direct current is passed through an electrolyte solution between an electrode and the workpiece. Chemical reaction, caused by the current in the electrolyte, dissolves the metal, as shown in Figure 4.28.

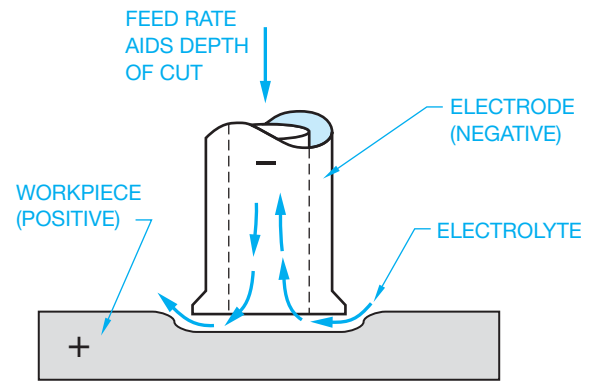


FIGURE 4.28 Electrochemical machining (ECM). © Cengage Learning 2012

### Electrodischarge Machining (EDM)

In **electrodischarge machining (EDM)**, the material to be machined and an electrode are submerged in a dielectric fluid that is a nonconductor, forming a barrier between the part and the electrode. A very small gap of about .001 in. (0.025 mm) is maintained between the electrode and the material. An arc occurs when the voltage across the gap causes the dielectric to break down. These arcs occur about 25,000 times per second, removing material with each arc. The compatibility of the material and the electrode is important for proper material removal. The advantages of EDM over conventional machining methods include its success in machining intricate parts and shapes that otherwise cannot be economically machined, and its use on materials that are difficult or impossible to work with, such as stainless steel, hardened steels, carbides, and titanium.

### Electron Beam (EB) Cutting and Machining

In **electron beam (EB) machining**, an electron beam generated by a heated tungsten filament is used to cut or machine very accurate features into a part. This process can be used to machine holes as small as .0002 in. (0.005 mm) or contour irregular shapes with tolerances of .0005 in. (0.013 mm). Electron beam cutting techniques are versatile and can be used to cut or machine any metal or nonmetal.

### Ultrasonic Machining

**Ultrasonic machining**, also known as *impact grinding*, is a process in which a high-frequency mechanical vibration is maintained in a tool designed to a specific shape. The tool and material to be machined are suspended in an abrasive fluid. The combination of vibration and abrasion causes material removal.

### Laser Machining

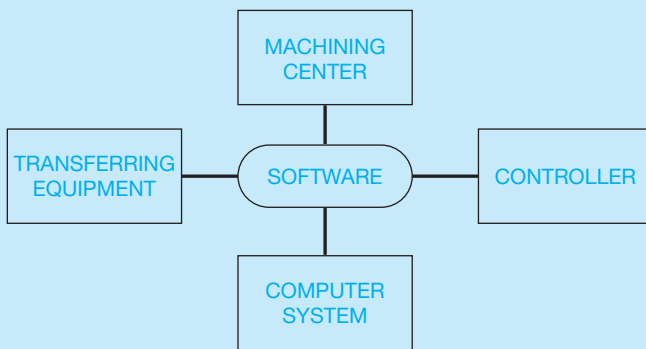
The **laser** is a device that amplifies focused light waves and concentrates them in a narrow, very intense beam. The term *laser* comes from the first letters of the description “light



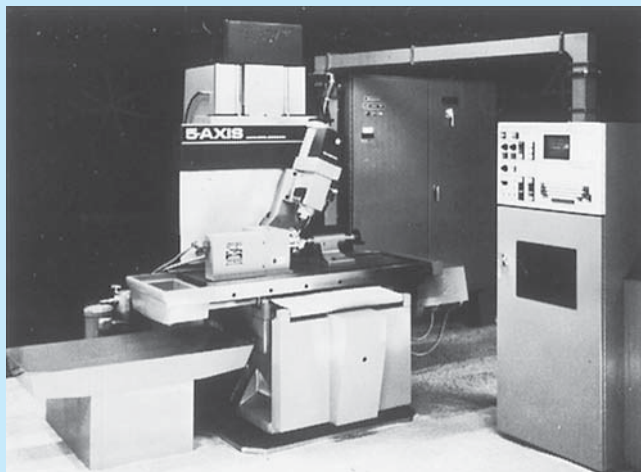
## COMPUTER NUMERICAL CONTROL (CNC) MACHINE TOOLS

Computer-aided design and drafting (CADD) has a direct link to computer-aided manufacturing (CAM) in the form of **computer numerical control (CNC)** machine tools. CNC refers to a computer controller that reads **G-code** instructions and drives the machine tool. G-code is a computer code used to establish the operation performed on the machine tool. CAM provides a direct link between CADD and CNC machine tools. A flowchart for the CNC process is shown in Figure 4.29. Figure 4.30 shows a CNC machine. In most cases, the drawing is generated in a computer, and this information is sent directly to the machine tool for production.

Many CNC systems offer a microcomputer base that incorporates a monitor display and full alphanumeric keyboard, making programming and online editing easy and fast. For example, data input for certain types of



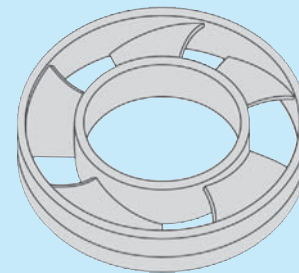
**FIGURE 4.29** The computer numerical control (CNC) process.  
© Cengage Learning 2012



**FIGURE 4.30** A CNC machine. Courtesy Boston Digital Corporation

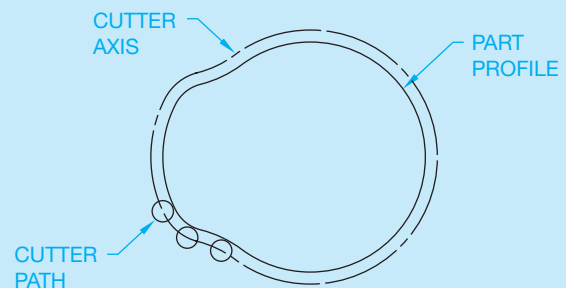
machining may result in the programming of one of several identical features while the other features are oriented and programmed automatically, such as the five equally spaced blades of the centrifugal fan shown in Figure 4.31. Among the advantages of CNC machining are increased productivity, reduction of production costs, and manufacturing versatility.

There is a special challenge when preparing drawings for CNC machining. The drawing method must coordinate with a system of controlling a machine tool by instructions in the form of numbers. The types of dimensioning systems that relate directly to CNC applications are tabular, arrowless, datum, and related coordinate systems. The main emphasis is to coordinate the dimensioning system with the movement of the machine tools. This can be best accomplished with datum dimensioning systems in which each dimension originates from a common beginning point. Programming the CNC system requires that cutter compensation be provided for contouring. This task is automatically calculated by computer in some CNC machines, as shown in Figure 4.32, or in software programs such as the CNC Software, Inc. product Mastercam and the SmartCAMcnc product SmartCAM. Definitions and examples of the dimensioning systems are discussed in Chapter 10, *Dimensioning and Tolerancing*.



Courtesy Boston Digital Corporation

**FIGURE 4.31** CNC programming of a part with five equally spaced blades. This figure demonstrates the CNC programming of one of the five equally spaced blades and the automatic orientation and programming of the other four blades.



Courtesy Boston Digital Corporation

**FIGURE 4.32** Automatic cutter compensation for profile machining.

amplification by stimulated emission of radiation.” Using this process, materials are cut or machined by instant temperatures as high as 75,000°F (41,649°C). **Laser machining** is the process by which a laser is used to cut materials. The laser melts or vaporizes the material at the point of impact with temperatures as high as 75,000°F (41,649°C), and the melted material is usually blown away from the cut by a stream of gas. Today, laser machining is common in manufacturing because of its production of smooth cutting surfaces and a small heat-affected zone. It can be used to cut almost any type of nonreflective material, including metal, glass, plastic, and wood. However, some materials such as PVC and fiberglass produce harmful toxins when melted. Laser machining is also capable of cutting through materials with thicknesses of up to .5 in. (12.7 mm) while holding tolerances of up to .002 in. (0.05 mm).

## MACHINED FEATURE AND DRAWING REPRESENTATIONS

The following discussion provides a brief definition of the common manufacturing-related terms. The figures that accompany each definition show an example of the tool, a pictorial of the feature, and the drawing representation. The terms are organized in categories of related features rather than presented in alphabetical order.

### Drill

A **drill** is a tool used to machine new holes or enlarge existing holes in material. The drilled hole can go through the part, in which case the note THRU can be added to the diameter dimension. When the views of the hole clearly show that the hole goes through the part, the note THRU can be omitted. When the hole does not go through, the depth must be specified. This is referred to as a **blind hole**. The drill depth is the total usable depth to where the drill point begins to taper. A drill is a conically shaped tool with cutting edges normally used in a drill press. The drawing representation of a drill point is a 120° total angle (see Figure 4.33).

### Ream

The tool used in the reaming process is called a **reamer**. The reamer is used to enlarge or finish a hole that has been drilled, bored, or cored. A cored hole is cast in place, as previously discussed. A reamer removes only a small amount of material: for example, .005 to .16 in. (0.1–1.6 mm), depending on the size of a hole. The intent of a reamed hole is to provide a smooth surface finish and a closer tolerance than is available with the existing hole. A reamer is a conically shaped tool with cutting edges similar to a drill; however, a reamer does not create a hole as with a drill. Reamers can be used on a drill press, lathe, or mill (see Figure 4.34).

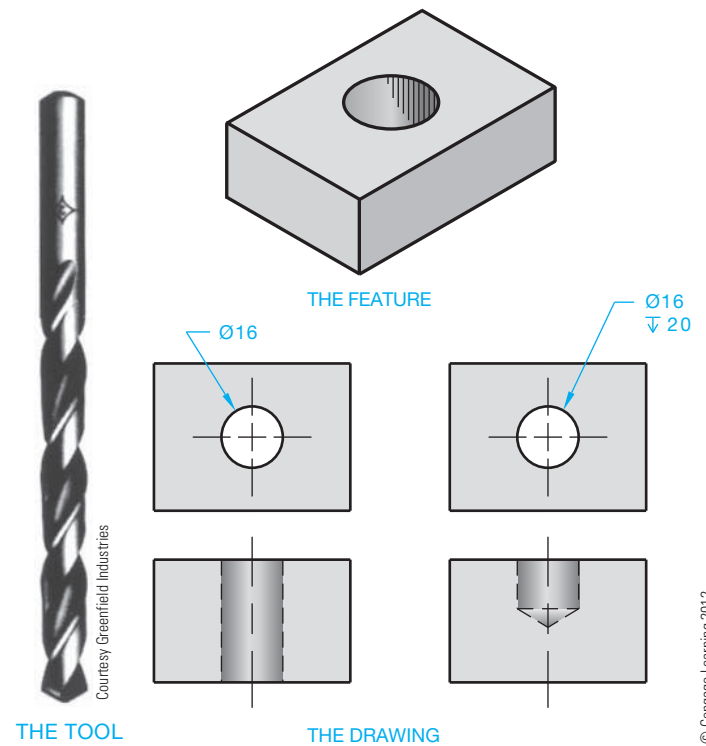


FIGURE 4.33 Drill.

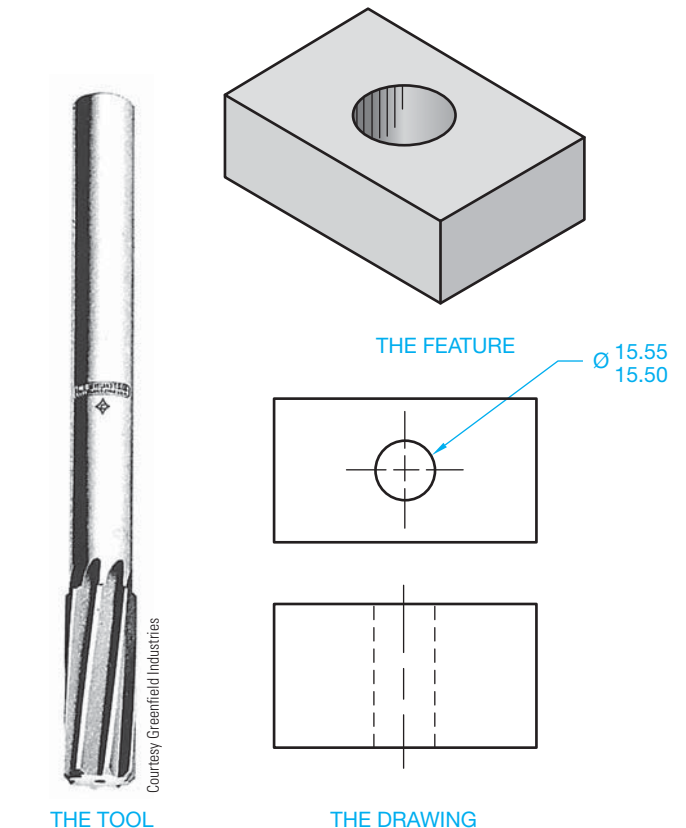


FIGURE 4.34 Reamer.

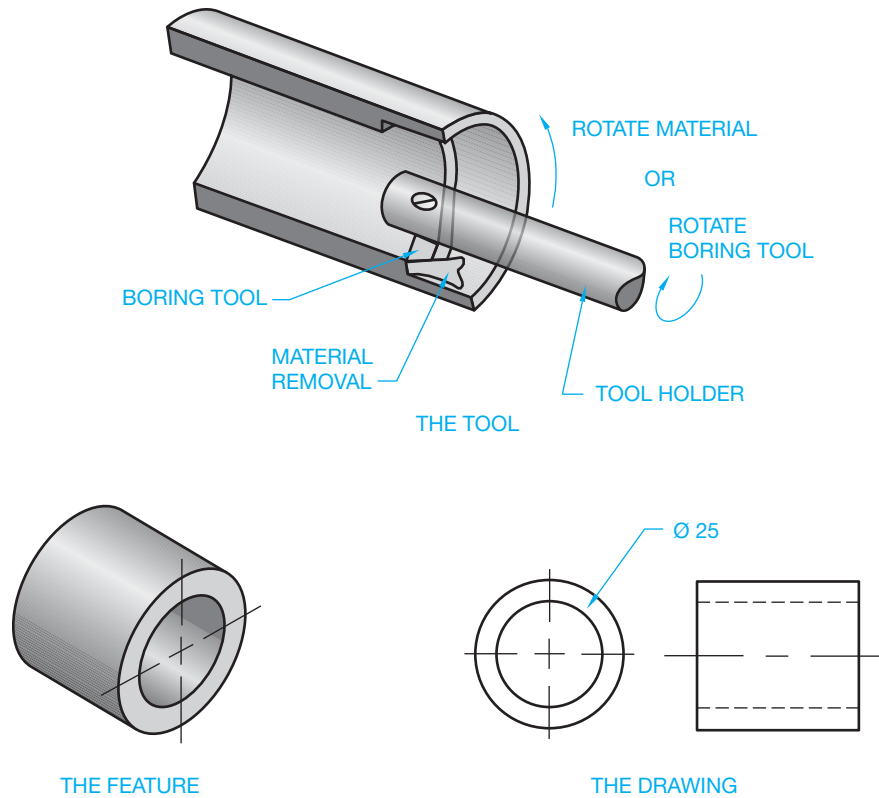


FIGURE 4.35 Bore. © Cengage Learning 2012

## Bore

**Boring** is the process of enlarging an existing hole. The purpose may be to make a drilled or cored hole in a cylinder or part concentric with or perpendicular to other features of the part. A boring tool is used on machines such as a lathe, milling machine, or vertical bore mill for removing internal material (see Figure 4.35).

## Counterbore

The **counterbore** is used to enlarge the end(s) of a machined hole to a specified diameter and depth. The machined hole is made first, and then the counterbore is aligned during the machining process by means of a pilot shaft at the end of the tool. Counterbores are usually made to recess the head of a fastener below the surface of the object. You should be sure that the diameter and depth of the counterbore are adequate to accommodate the fastener head and fastening tools (see Figure 4.36).

## Countersink

A **countersink** is a conical feature at the end of a machined hole. Countersinks are used to recess the conically shaped head of a fastener such as a flathead machine screw. The drafter should

specify the countersink note so that the fastener head is recessed slightly below the surface. The total countersink angle should match the desired screw head. This angle is generally  $80^\circ$  to  $82^\circ$  or  $99^\circ$  to  $101^\circ$  (see Figure 4.37).

## Counterdrill

A **counterdrill** is a combination of two drilled features. The first machined feature may go through the part while the second feature is drilled to a given depth into one end of the first. The result is a machined hole that looks similar to a countersink–counterbore combination. The angle at the bottom of the counterdrill is a total of  $120^\circ$ , as shown in Figure 4.38.

## Spotface

A **spotface** is a machined, round surface on a casting, forging, or machined part on which a bolt head or washer can be seated. Spotfaces are similar in characteristics to counterbores, except that a spotface is generally only about .08 in. (2 mm) or less in depth. Rather than a depth specification, the dimension from the spotface surface to the opposite side of the part can be given. This is also true for counterbores, although the depth dimension is commonly provided in the

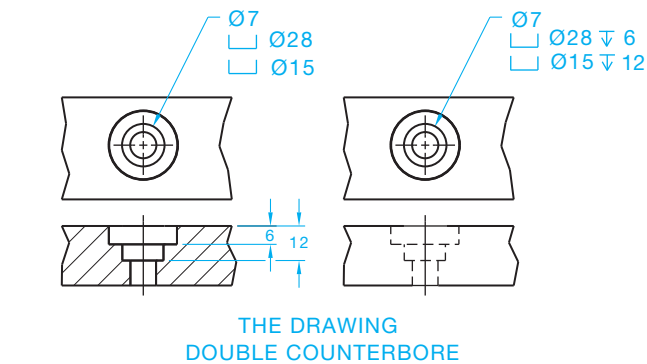
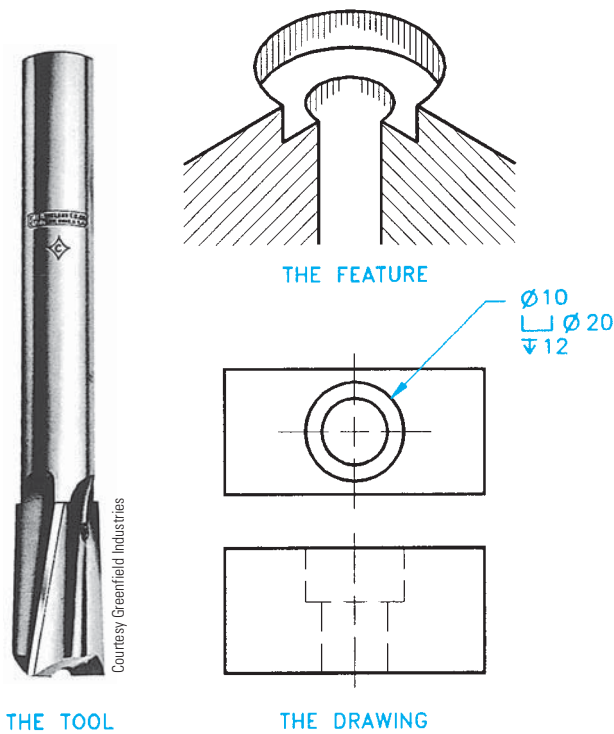


FIGURE 4.36 Counterbore.

note. When no spotface depth is given, the machinist will spotface to a depth that establishes a smooth cylindrical surface (see Figure 4.39).

**Boss**

A **boss** is a circular pad on forgings or castings that projects out from the body of the part. Although more closely related to castings and forgings, the surface of the boss is often machined smooth for a bolt head or washer surface to seat on. In addition, the boss commonly has a hole machined through it to accommodate the fastener's shank (see Figure 4.40).

**Lug**

Generally cast or forged into place, a **lug** is a feature projecting out from the body of a part, usually rectangular in cross section. Lugs are used as mounting brackets or function as

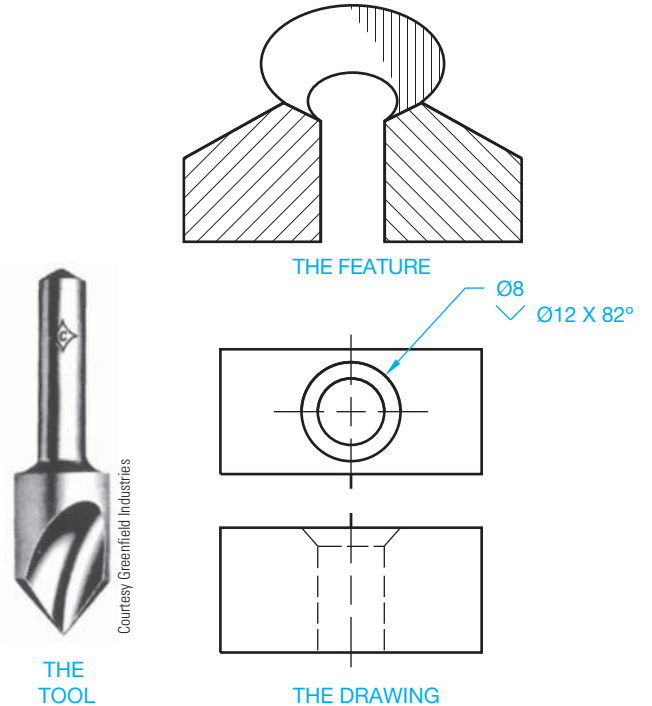


FIGURE 4.37 Countersink.

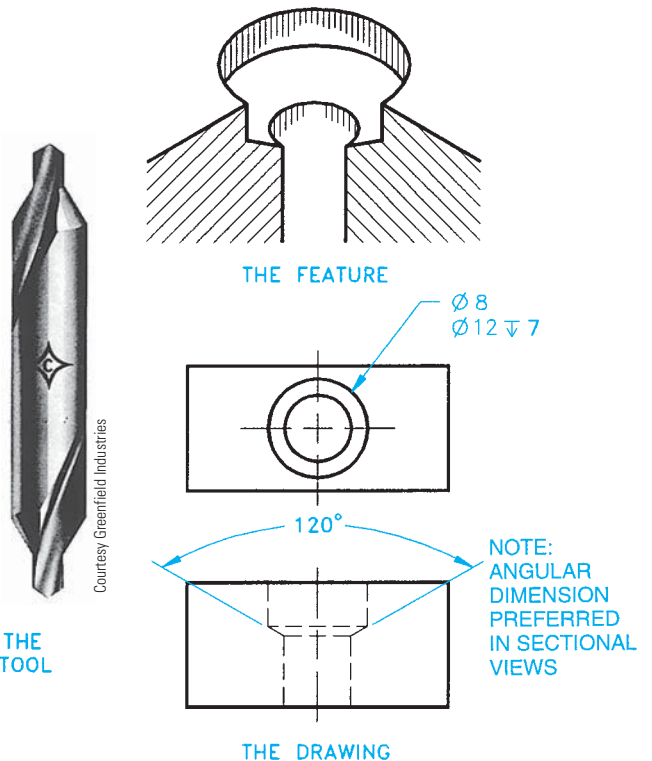


FIGURE 4.38 Counterdrill.

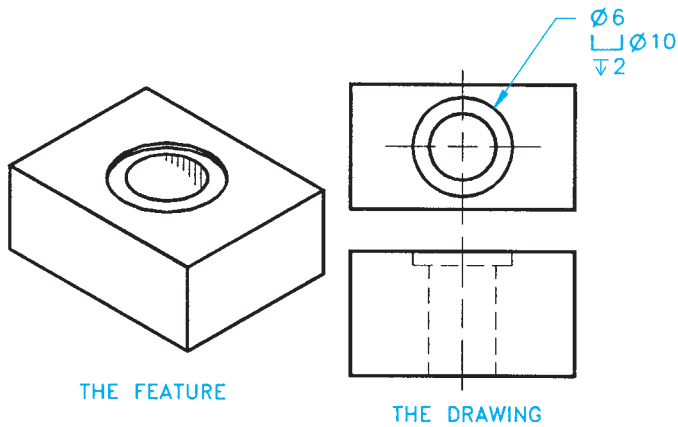


FIGURE 4.39 Spotface. © Cengage Learning 2012

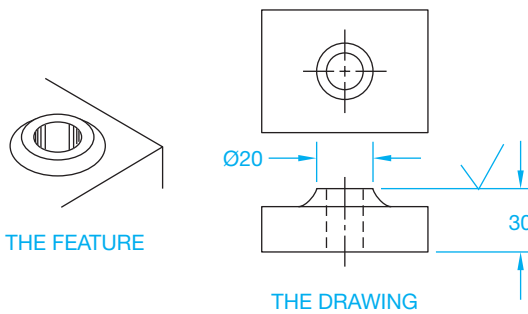


FIGURE 4.40 Boss. © Cengage Learning 2012

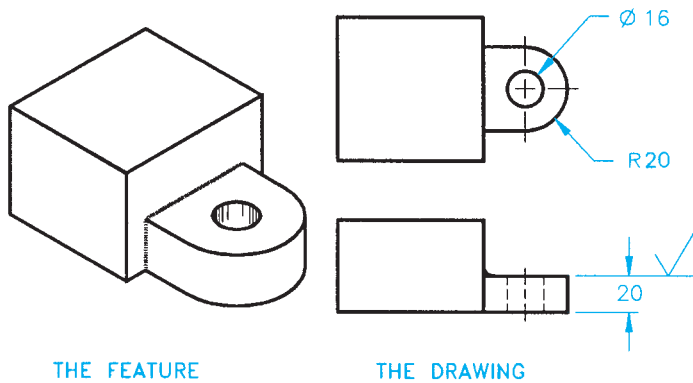


FIGURE 4.41 Lug. © Cengage Learning 2012

holding devices for machining operations. Lugs are commonly machined with a drilled hole and a spotface to accommodate a bolt or other fastener (see Figure 4.41).

## Pad

A **pad** is a slightly raised surface projecting out from the body of a part. The pad surface can be any size or shape. The pad can be cast, forged, or machined into place. The surface is often machined to accommodate the mounting of an adjacent part. A boss is a type of pad, although the boss is always cylindrical in shape (see Figure 4.42).

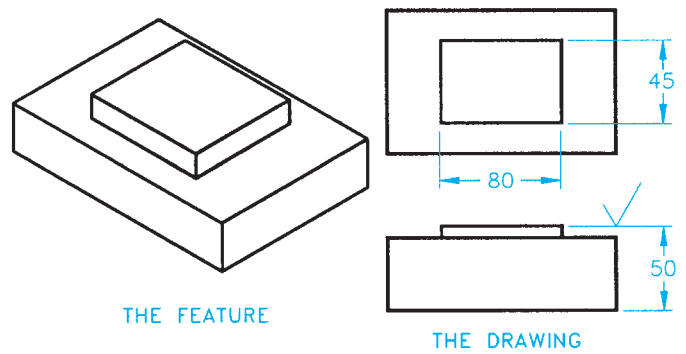
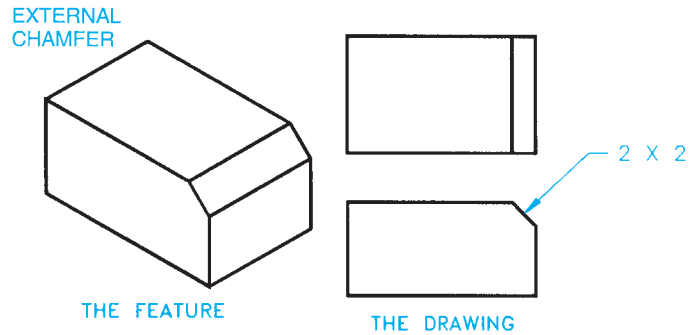
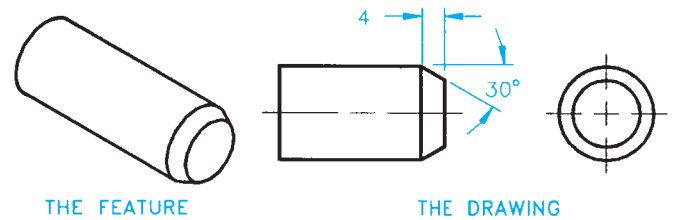


FIGURE 4.42 Pad. © Cengage Learning 2012



## CYLINDRICAL CHAMFER



## INTERNAL CHAMFER

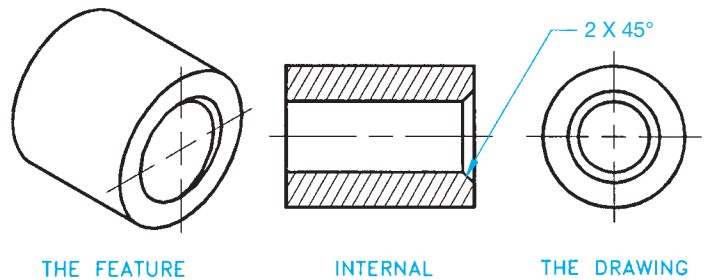


FIGURE 4.43 Chamfers. © Cengage Learning 2012

## Chamfer

A **chamfer** is the cutting away of the sharp external or internal corner of an edge. Chamfers can be used as a slight angle to relieve a sharp edge or to assist the entry of a pin or thread into the mating feature (see Figure 4.43). Verify alternate methods of dimensioning chamfers in Chapter 10.

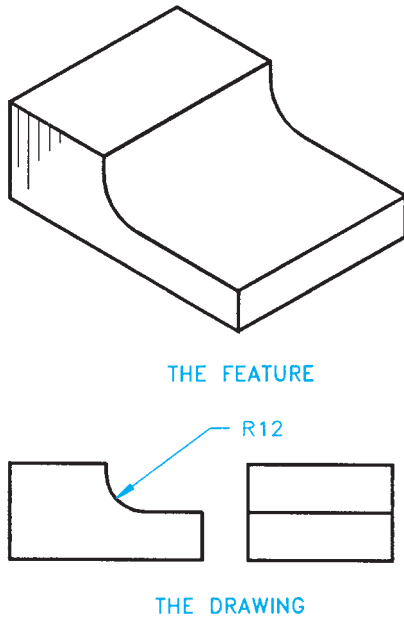


FIGURE 4.44 Fillet. © Cengage Learning 2012

### Fillet

A **fillet** is a small radius formed between the inside angle of two surfaces. Fillets are often used to help reduce stress and strengthen an inside corner. They are common on the inside corners of castings and forgings to strengthen corners and reduce stress during molding. Fillets are also used to help a casting or forging release a mold or die. Fillets are arcs given as radius dimensions. The fillet size depends on the function of the part and the manufacturing process used to make the fillet (see Figure 4.44).

### Round

A **round** is a small-radius outside corner formed between two surfaces. Rounds are used to refine sharp corners, as shown in Figure 4.45. In situations in which a sharp corner must be relieved and a round is not required, a slight corner relief can be used, referred to as a **break corner**. The note BREAK CORNER can be used on the drawing. Another option is to provide a note that specifies REMOVE ALL BURRS AND SHARP EDGES. **Burrs** are machining fragments that are often left on a part after machining.

### Dovetail

A **dovetail** is a slot with angled sides that can be machined at any depth and width. Dovetails are commonly used as a sliding mechanism between two mating parts (see Figure 4.46).

### Kerf

A **kerf** is a narrow slot formed by removing material while sawing or using some other machining operation (see Figure 4.47).

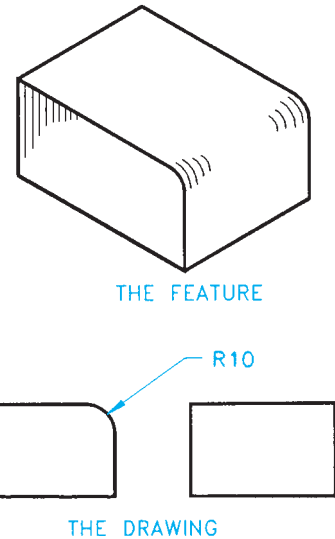


FIGURE 4.45 Round. © Cengage Learning 2012

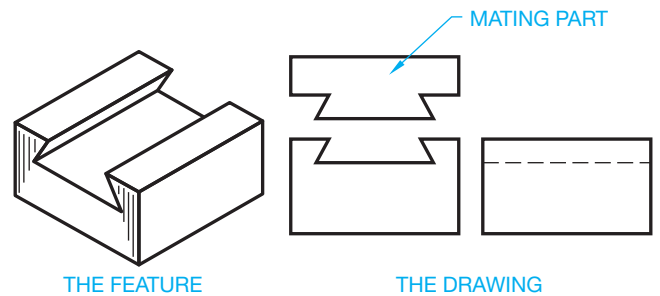


FIGURE 4.46 Dovetail. © Cengage Learning 2012

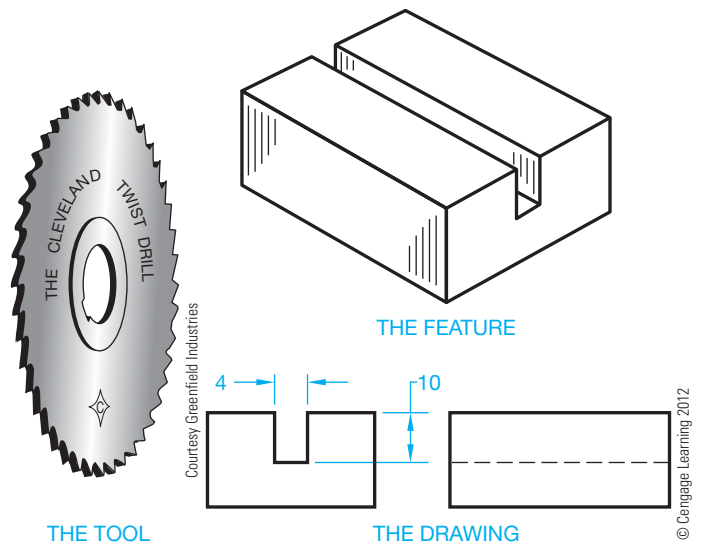


FIGURE 4.47 Kerf.

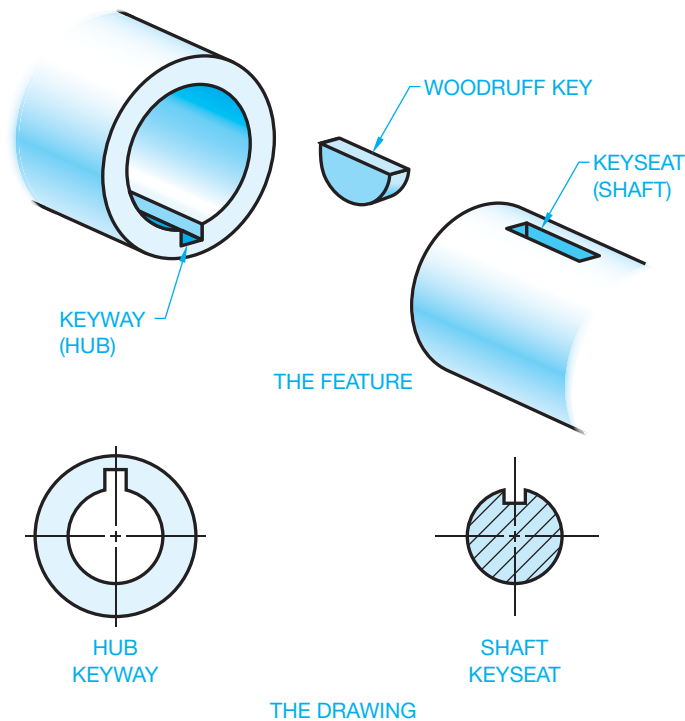


FIGURE 4.48 Key, keyseat, keyway. © Cengage Learning 2012

### Key, Keyseat, Keyway

A **key** is a machine part that is used as a positive connection for transmitting torque between a shaft and a hub, pulley, or wheel. The key is placed in position in a **keyseat**, which is a groove or channel cut in a shaft. The shaft and key are then inserted into a hub, wheel, pulley, gear, or sprocket where the key mates with a groove called a **keyway**. There are several different types of keys. The key size is often determined by the shaft size and load requirements (see Figure 4.48). Types of keys and key sizes are discussed in Chapter 11, *Fasteners and Springs*.

### Neck

A **neck** is the result of a machining operation that establishes a narrow groove on a cylindrical part or object. There are several different types of neck grooves, as shown in Figure 4.49. Dimensioning necks is clearly explained in Chapter 10.

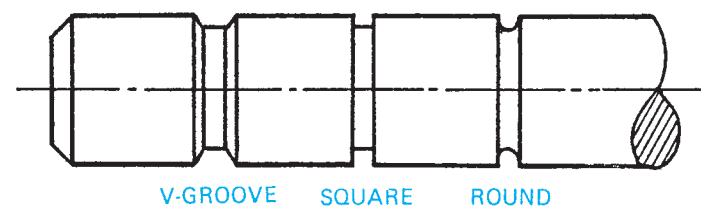


FIGURE 4.49 Neck. © Cengage Learning 2012

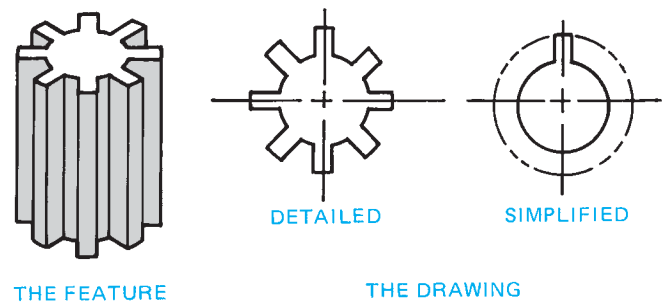


FIGURE 4.50 Spline. © Cengage Learning 2012

### Spline

A **spline** is a gearlike surface on a shaft and in a mating hub. Splines are used to transmit torque and allow for lateral sliding or movement between two shafts or mating parts. A spline can be used to take the place of a key when more torque strength is required or when the parts must have lateral movement (see Figure 4.50).

### Threads

There are many different forms of threads available that are used as fasteners to hold parts together, to adjust parts in alignment with each other, or to transmit power. Threads that are used as fasteners are commonly referred to as **screw threads**. External threads are thread forms on an external feature such as a bolt or shaft. The machine tool used to make external threads is commonly called a **die** (see Figure 4.51). Threads can be

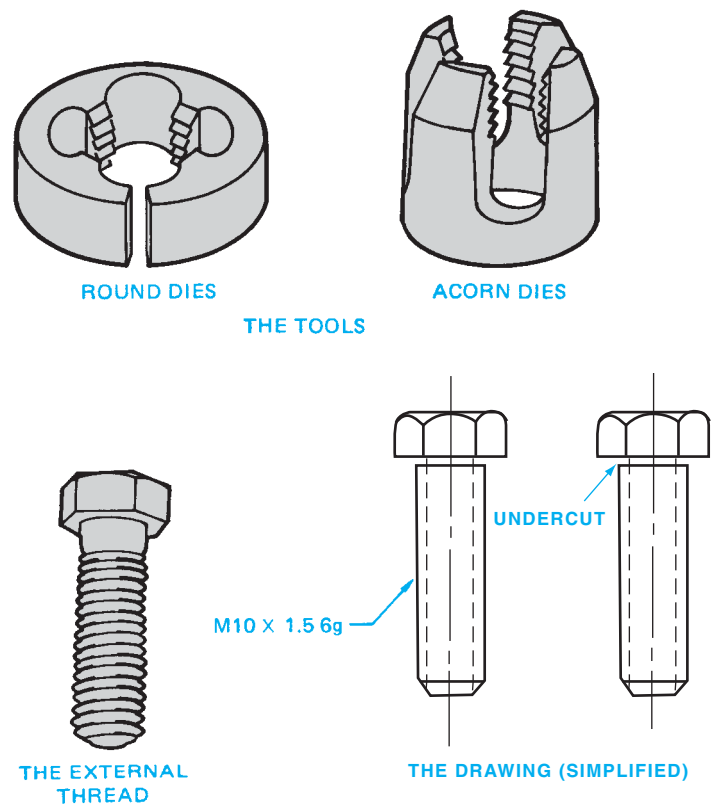


FIGURE 4.51 External thread. © Cengage Learning 2012

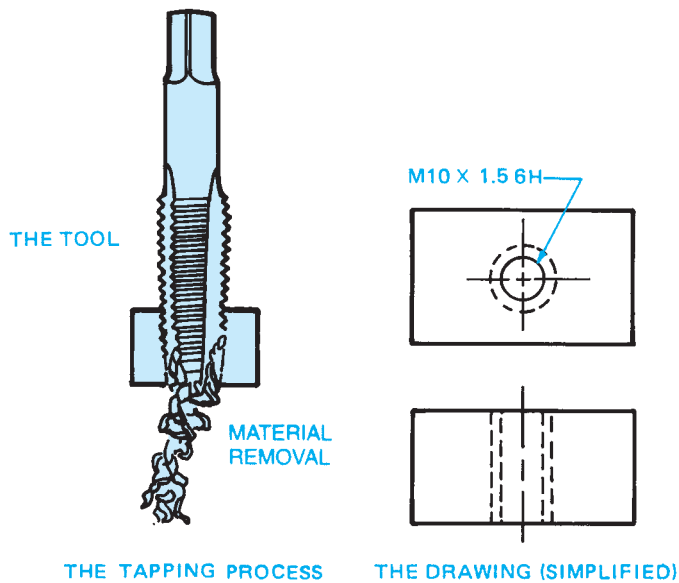


FIGURE 4.52 Internal thread. © Cengage Learning 2012

machined on a lathe using a thread-cutting tool. The external thread can be machined on a fastener, such as the hexagon head bolt shown in Figure 4.51, or on a shaft without a head. This is referred to as a *threaded rod*. An external thread can also be machined on a shaft of one diameter that meets a shaft of a larger diameter. Sometimes a neck is machined where the external thread meets the fastener head or the larger-diameter shaft. This neck is referred to as an **undercut**, as shown in the right example in Figure 4.51. The undercut is used to eliminate the possibility of a machine radius at the head and to allow for a tight fit between the thread and the head when assembled. Internal threads are threaded features on the inside of a hole. The machine tool that is commonly used to cut internal threads is called a **tap** (see Figure 4.52).

## T-slot

A **T-slot** is a slot of any dimension that is cut in the shape of a capital T. The T-slot can be used as a sliding mechanism between two mating parts (see Figure 4.53).

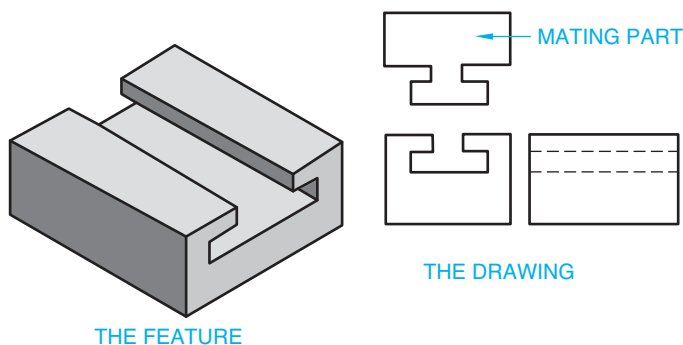


FIGURE 4.53 T-slot. © Cengage Learning 2012

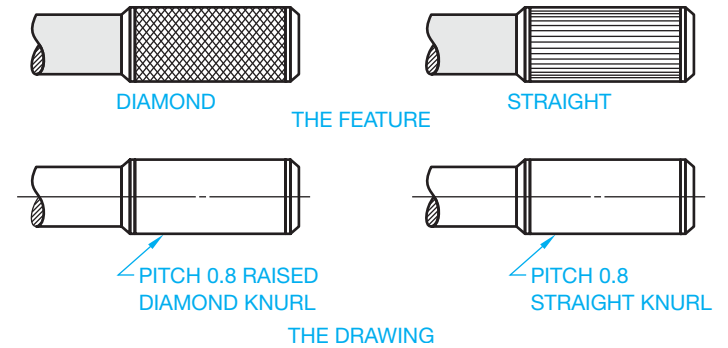


FIGURE 4.54 Knurl. © Cengage Learning 2012

## Knurl

**Knurling** is a cold forming process used to roughen a cylindrical or flat surface uniformly with a diamond or straight pattern. Knurls are often used on handles or other gripping surfaces. Knurls may also be used to establish an interference (press) fit between two mating parts. To create a knurl, machinists use a lathe to slowly spin a knurling tool, which consists of two rotary cutters that deform (or remove) the material. The actual knurl texture is not displayed on the drawing (see Figure 4.54).

## Surface Texture

**Surface texture**, or **surface finish**, is the intended condition of the material surface after manufacturing processes have been implemented. Surface texture includes such characteristics as roughness, waviness, lay, and flaws. Surface roughness is one of the most common characteristics of surface finish, which consists of the finer irregularities of the surface texture partly resulting from the manufacturing process. The surface roughness is measured in micrometers ( $\mu\text{m}$ ) or microinches ( $\mu\text{in.}$ ). **Micro** ( $\mu$ ) means millionth. The roughness averages for different manufacturing processes are shown in Appendix E. Surface finish is considered a dimensioning specification and therefore is discussed in detail in Chapter 10.

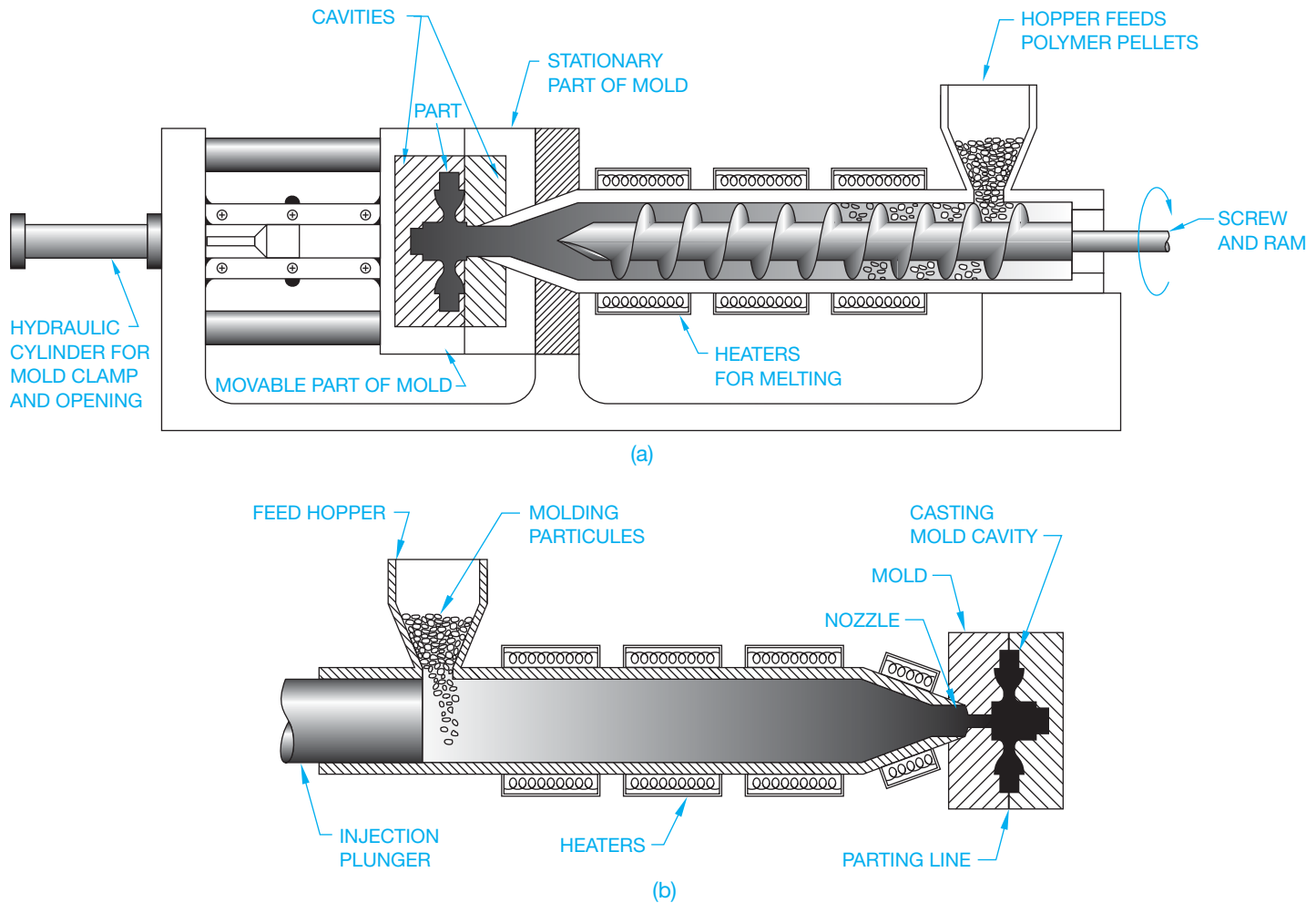
## MANUFACTURING PLASTIC PRODUCTS

Earlier discussions provided general information about the different types of plastics and synthetic rubbers, and products that are commonly made from these materials. The traditional manufacturing processes for plastic products include injection molding, extrusion, blow molding, compression molding, transfer molding, and thermoforming. These processes are explained in the following discussion.

## Injection Molding Process

**Injection molding** is the most commonly used process for creating thermoplastic products. The process involves injecting molten plastic material into a mold that is in the form of





**FIGURE 4.55** (a) The process of creating a product and the parts of the screw injection system. (b) The process of creating a product and the parts of the nozzle injection system. © Cengage Learning 2012

the desired part or product. The mold is in two parts that are pressed together during the molding process. The mold is then allowed to cool so the plastic can solidify. When the plastic has cooled and solidified, the press is opened and the part is removed from the mold. The injection molding machine has a hopper in which either powder or granular material is placed. The material is then heated to a melting temperature. The molten plastic is then fed into the mold by an injection nozzle or a screw injection system.

The injection system is similar to a large hypodermic needle and plunger that pushes the molten plastic material into the mold. The most commonly used injection system is the screw machine. This machine has a screw design that transports the material to the injection nozzle. While the material moves toward the mold, the screw also mixes the plastic to a uniform consistency. This mixing process is an important advantage over the plunger system. Mixing is especially important when color is added or when recycled material is used. The process of creating a product and the parts of the screw injection and injection nozzle systems are shown in Figure 4.55.

## Extrusion Process

The **extrusion process** is used to make continuous shapes such as moldings, tubing, bars, angles, hose, weather stripping, films, and any product that has a constant cross-sectional shape. This process creates the desired continuous shape by forcing molten plastic through a metal die. The extrusion process typically uses the same type of injection nozzle or a screw injection system that is used in the injection molding process. The contour of the die establishes the shape of the extruded plastic. Figure 4.56 shows the extrusion process in action.

## Blow Molding Process

The **blow molding process** is commonly used to produce hollow products such as bottles, containers, receptacles, and boxes. This process works by blowing hot polymer against the internal surfaces of a hollow mold. The molten plastic enters around a tube that also forces air inside the material, which forces it against the interior surface of the mold. The polymer expands to a uniform thickness against the mold. The mold is

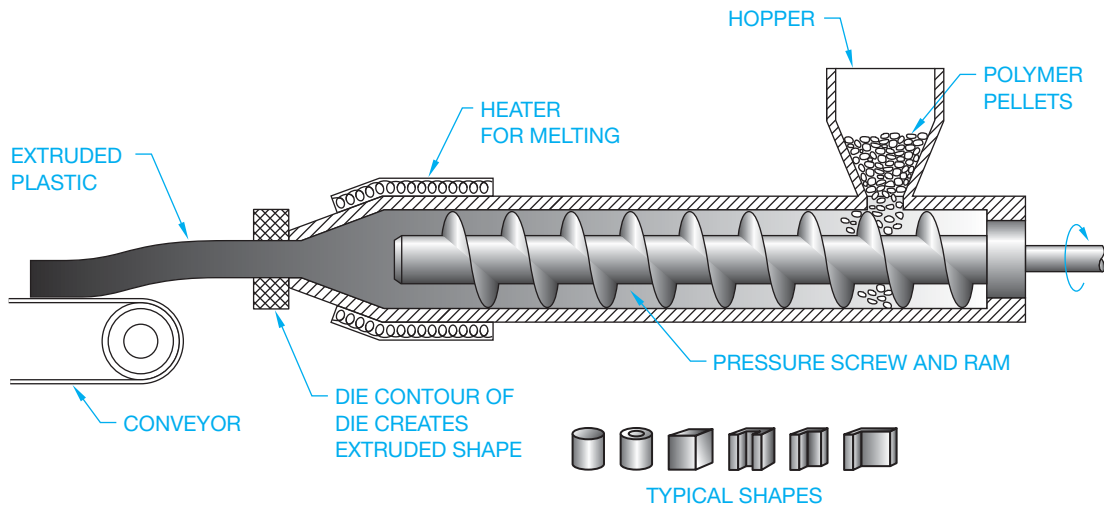


FIGURE 4.56 The extrusion process in action. © Cengage Learning 2012

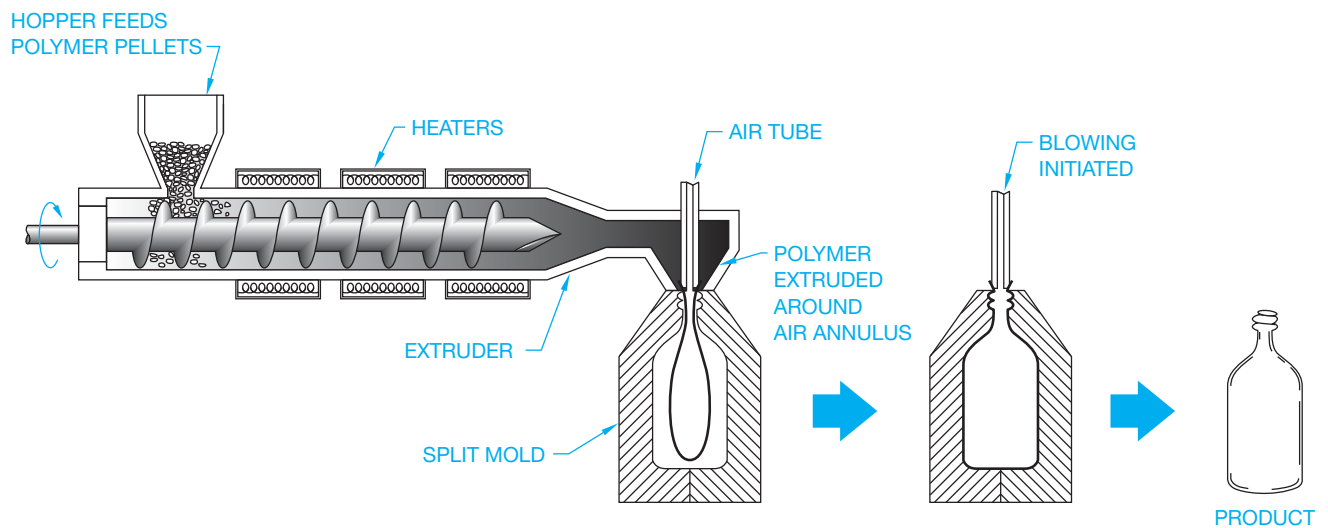


FIGURE 4.57 The blow molding process. © Cengage Learning 2012

formed in two halves, so when the plastic cools, the mold is split to remove the product. Figure 4.57 shows the blow molding process.

## Calendering Process

The **calendering process** is generally used to create products such as vinyl flooring, gaskets, and other sheet products. This process fabricates sheet or film thermoplastic or thermoset plastics by passing the material through a series of heated rollers. The space between the sets of rollers gets progressively smaller until the distance between the last set of rollers establishes the desired material thickness. Figure 4.58 illustrates the calendering process used to produce sheet plastic products.

## Rotational Molding Process

The **rotational molding process** is typically used to produce large containers such as tanks, hollow objects such as floats, and other similar types of large, hollow products. This process

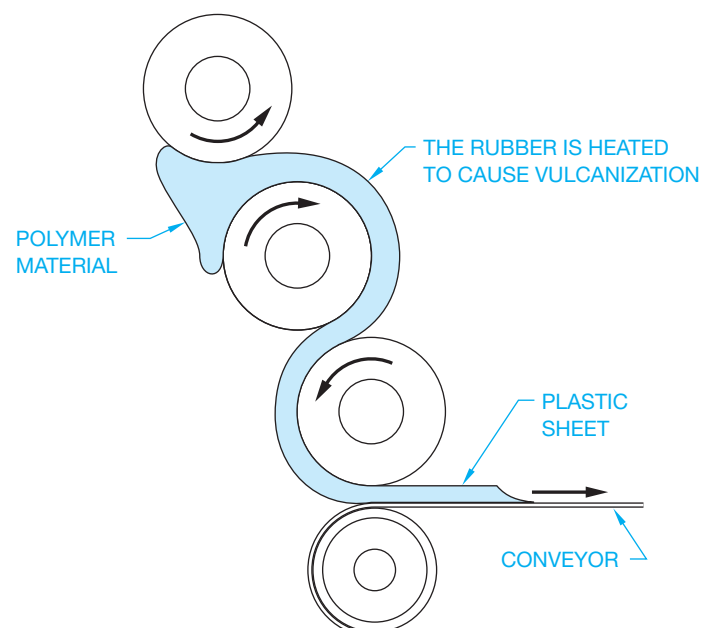


FIGURE 4.58 The calendering process used to produce sheet plastic products. © Cengage Learning 2012

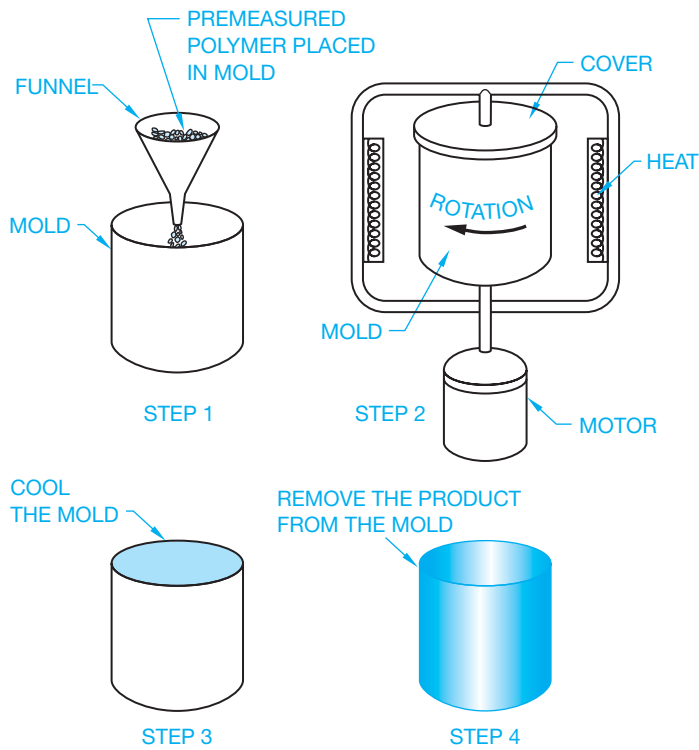


FIGURE 4.59 The rotational molding process. © Cengage Learning 2012

works by placing a specific amount of polymer pellets into a metal mold. The mold is then heated as it is rotated. This forces the molten material to form a thin coating against the sides of the mold. When the mold is cooled, the product is removed. Figure 4.59 shows the rotational molding process.

### Solid Phase Forming Process

The **solid phase forming process** is used to make a variety of objects, including containers, electrical housings, automotive parts, and anything with detailed shapes. Products can be stronger using this process because the polymer is heated but not melted. The solid phase forming process works by placing material into an initial hot die where it takes the preliminary shape. As the material cools, a die that matches the shape of the desired product forms the final shape. This process is similar to metal forging. Figure 4.60 shows the solid phase forming process.

### Thermoforming of Plastic

**Thermoforming of plastic** is similar to solid phase forming but can be done without a die. This process is used to make all types of thin-walled plastic shapes such as containers, guards, fenders, and other similar products. The process works by taking a sheet of material and heating it until it softens and sinks down by its own weight into a mold that conforms to the desired final shape. Vacuum pressure is commonly used to suck the hot material down against the mold, as shown in Figure 4.61.

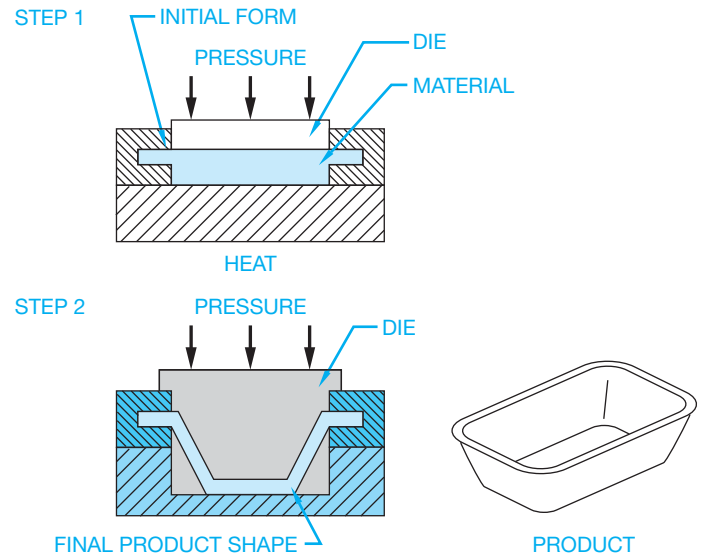


FIGURE 4.60 The solid phase forming process. © Cengage Learning 2012

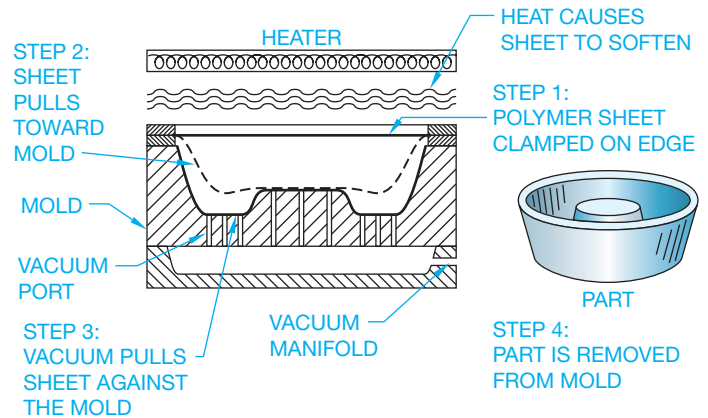


FIGURE 4.61 Thermoforming of plastic. Vacuum pressure is commonly used to suck the hot material down against the mold. © Cengage Learning 2012

### Free-Form Fabrication of Plastic

The **free-form fabrication (FFF)** is the term used to describe the techniques for fabricating parts directly from 3-D CAD models. These techniques have adapted with technology; today there are multiple methods of free-form fabrication for plastic and metal. In general, a 3-D CAD model is used to control a laser that deposits layers of liquid resin or molten particles of plastic material onto a structure to form the desired shape. Another method uses the laser to fuse several thin coatings of powder polymer to form the desired shape. This process is often referred to by the trade name **stereolithography (SLA)** or **3-D printing**. The free-form fabrication process can be used for prototyping, tool production, and design visualization aids. This is discussed further with the content covering rapid prototypes later in this chapter. Figure 4.62 shows an illustration of the free-form process.

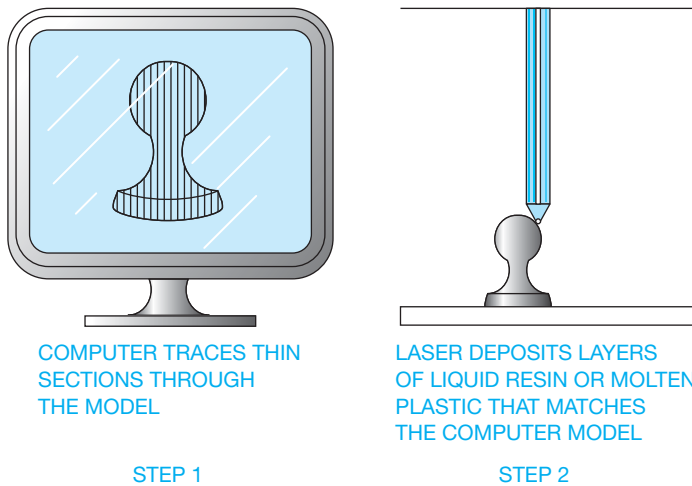


FIGURE 4.62 The free-form fabrication process. © Cengage Learning 2012

## THERMOSET PLASTIC FABRICATION PROCESS

The manufacture of thermoset products can be more difficult than thermoplastic fabrication because thermosets cannot be remelted once they have been melted and formed. This characteristic makes it necessary to keep the manufacturing equipment operational for as much time as possible. When process equipment is shut down, it must be thoroughly cleaned before the thermoset material solidifies. The injection molding process discussed earlier can be used with thermoset plastic, but extreme care must be taken to ensure that the equipment is kept clean. For this reason, other methods are commonly used for manufacturing thermoset products. Thermoset plastic production generally takes longer than thermoplastic production because thermoset plastics require a longer cure time. The most common production practices are casting, compression molding, foam molding, reaction injection molding, transfer molding, sintering, and vulcanization.

### Casting Thermoset Plastics

The method used to cast plastics is very similar to the permanent casting of metals explained earlier in this chapter. When casting plastic, the molten polymer or resin is poured into a metal flask with a mold that forms the desired shape of the product. The plastic product is removed when it has solidified. The casting process is shown in Figure 4.63.

### Compression Molding and Transfer Molding

**Compression molding** and **transfer molding** are common fabrication processes for thermosets. The compression molding process uses a specific amount of material that is heated and

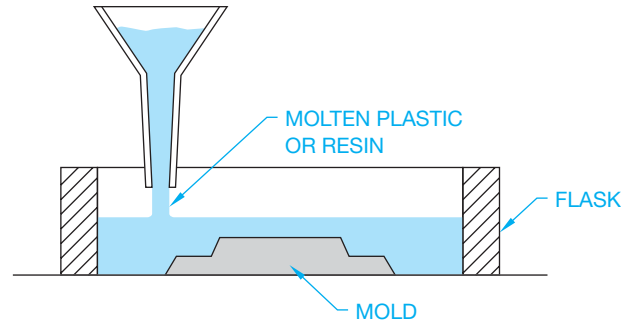


FIGURE 4.63 Casting thermoplastics. © Cengage Learning 2012

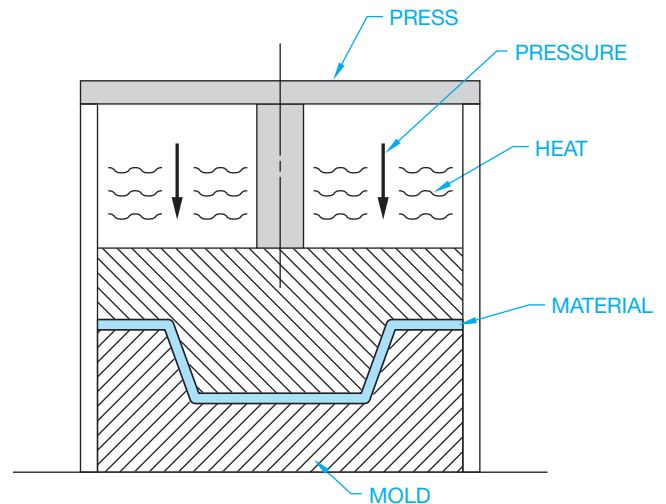


FIGURE 4.64 The compression molding process. © Cengage Learning 2012

placed in a closed mold where additional heat and pressure are applied until the material takes the desired shape. The material is then cured and removed from the mold. Figure 4.64 shows the compression molding process.

Transfer molding is similar to compression molding for thermoset plastic products. In this process, the material is heated and then forced under pressure into the mold.

### Foam Molding and Reaction Injection Molding

**Foam molding** is similar to casting, but this process uses a foam material that expands during the cure to fill the desired mold. The foam molding process can be used to make products of any desired shape or sheets of foam products. The foam molding process is used to make a duck decoy in Figure 4.65.

The **reaction injection molding process** is similar to the foam process because the material that is used expands to fill the mold. This process is often used to fabricate large parts such as automobile dashboards and fenders. Polymer chemicals are mixed together under pressure and then poured into the mold where they react and expand to fill the mold.

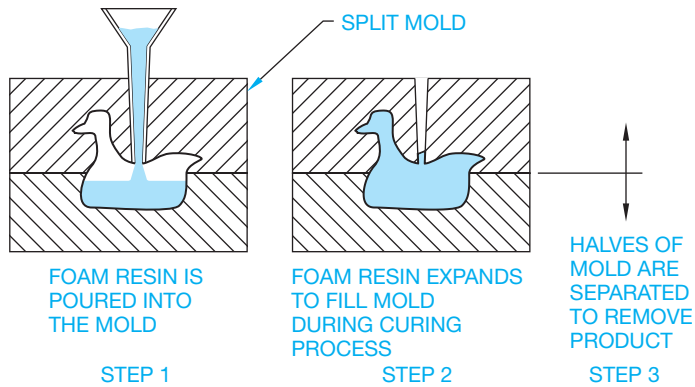


FIGURE 4.65 The foam molding process. © Cengage Learning 2012

## Sintering Process

Sintering is a process that takes powdered particles of material and produces detailed products under heat, pressure, and chemical reaction. The powder particles do not melt, but they join into a dense and solid structure. This process is used when creating products for high-temperature applications. This process was described earlier as related to metal casting under the heading Powder Metallurgy (PM).

## Vulcanization Process

Vulcanization is used to make rubber products such as tires and other circular and cylindrical shapes, although other shapes are commonly produced. This process works by wrapping measured layers of the polymer around a steel roll in the form of the desired product. The steel roll and material are placed inside an enclosure where steam is introduced to create heat and pressure. This process forces the molecules of the material to form a solid rubber coating on the roll. The vulcanization process is a chemical reaction that cannot be displayed, a representation of the process is shown in Figure 4.66.

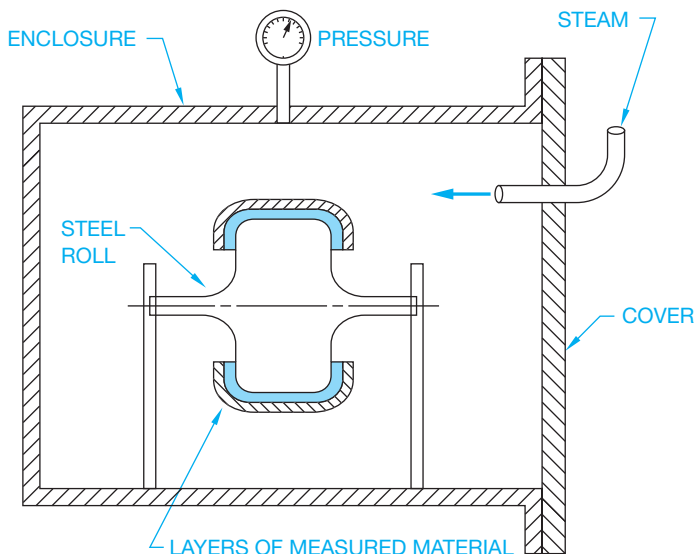


FIGURE 4.66 The vulcanization process. © Cengage Learning 2012

## MANUFACTURING COMPOSITES

Composites are also referred to as **reinforced plastics**. Earlier in this chapter, there was a discussion about composite materials. These materials combine polymers with reinforcing material such as glass, graphite, thermoplastic fibers, cotton, paper, and metal. The result is very strong material for use in products such as boats, planes, automobile parts, fishing rods, electrical devices, corrosion-resistant containers, and structural members. Composites are less expensive to produce and can be stronger and lighter in weight than many metals, including aluminum, steel, and titanium. The basics of producing composite products are the layering of polymer and reinforcing material in alternate coats or in combination.

## Layering Process

The **layering process** combines alternating layers of polymer resin with reinforcing material such as glass. The number of layers determines the desired thickness. During the curing process, the resin saturates the reinforcing material, creating a unified composite. Rolling or spraying over the reinforcing material can apply layering in the resin. A similar method uses a spray of resin combined with pieces of reinforcing material. This method is called *chopped fiber spraying*. Another process called *filament winding* uses machines to wind resin-saturated reinforcement fibers around a shaft.

## Compression Molding of Composites

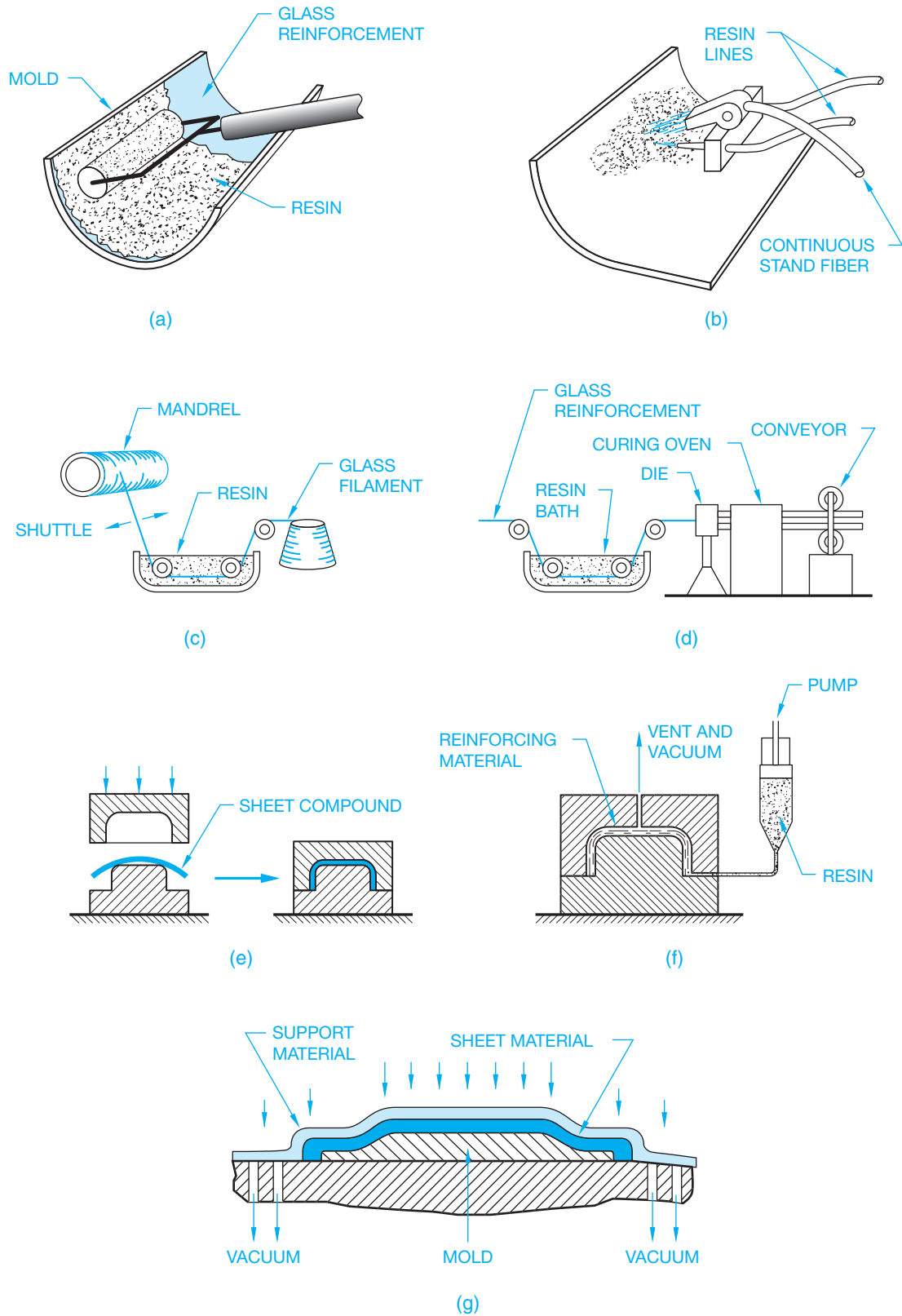
A process called compression molding is similar to the compression molding process explained earlier for thermoset plastic products. The difference is that mixing the polymer with reinforcing fibers creates composites. A similar process takes continuous reinforcing strands through a resin bath and then through a forming die. The die forms the desired shape. This method is often used to create continuous shapes of uniform cross section.

## Resin Transfer Molding

A process called **resin transfer molding** is used to make quality composite products with a smooth surface on both sides. This method places reinforcing material into a mold and then pumps resin into the mold.

## Vacuum Bag Forming

A process referred to as **vacuum bag forming** uses vacuum pressure to force a thin layer of sheet-reinforced polymer around a mold. Figure 4.67 shows a variety of processes used to make composite products.



**FIGURE 4.67** Common processes used to make composite products. (a) The layering process using rolling. (b) The layering process using spraying. (c) Filament winding. (d) The continuous reinforcing strands process. (e) Compression molding. (f) Resin transfer molding. (g) Vacuum bag forming.

© Cengage Learning 2012

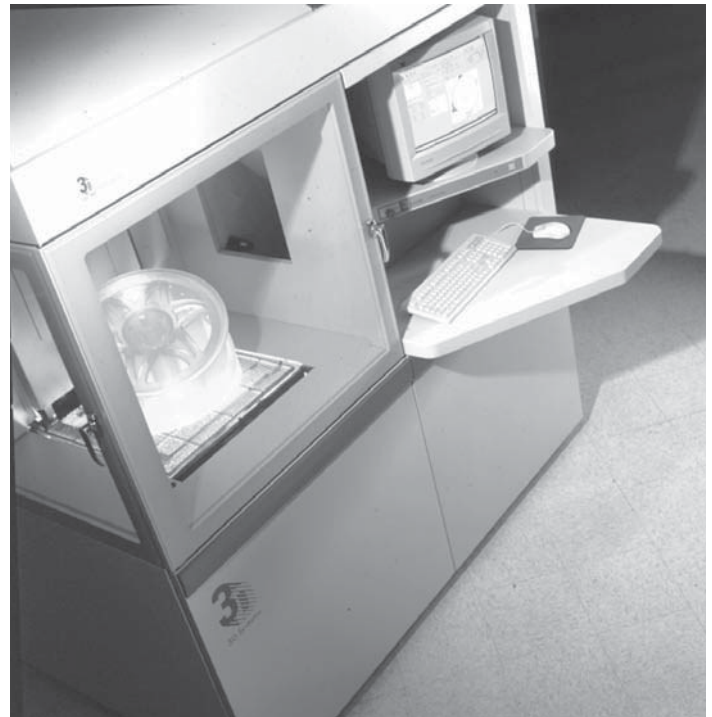
## RAPID PROTOTYPING (RP)

**Rapid prototyping (RP)** is a manufacturing process by which a solid physical model of a part is made directly from 3-D CADD model data without any special tooling. An **RP model** is a physical 3-D model that can be created far more quickly than by using standard manufacturing processes. Examples of RP are stereolithography and **fused deposition modeling (FDM)**, or 3-D printing. Stereolithography is one of the most common RP systems. The system uses a computer-controlled ultraviolet laser beam to harden a photocurable liquid resin to produce 3-D copies of CADD models. Fused deposition modeling (FDM) is a rapid prototyping process used to produce functional ABS thermoplastic models directly from CADD data. The system uses a CNC-controlled extruder head that squeezes a fine filament of melted thermoplastic through a nozzle. The nozzle deposits the heated plastic layer by layer to form the desired shape. The liquid material hardens immediately on contact in the cooler environment. The 3-D printing creates parts by placing successive layers of material and is the least expensive PR process.

Rapid prototyping equipment accepts 3-D CADD files, slices the data into thin cross sections, and constructs layers from the bottom up, bonding one on top of the other, to produce physical prototypes. CADD software such as Pro/Engineer allows you to export an RP file from a solid model in the form of an .stl file.

A computer using postprocessing software slices the 3-D CADD data into .005–.013 in. thick cross-sectional planes. Each slice or “layer” is composed of closely spaced lines resembling a honeycomb. The slice is shaped like the cross section of the part. The cross sections are sent from the computer to the rapid prototyping machine, which builds the part one layer at a time. The stereolithography machine has a “vat” that contains a photosensitive liquid epoxy plastic; a flat platform or starting base rests just below the surface of the liquid (see Figure 4.68). A laser, controlled with bidirectional motors, is positioned above the vat perpendicular to the surface of the polymer. The first layer is bonded to the platform by the heat of a thin laser beam that traces the lines of the layer onto the surface of the liquid polymer. When the first layer is completed, the platform is lowered the thickness of a layer. Additional layers are bonded on top of the first in the same manner, according to the shape of their respective cross section. This process is repeated until the prototype part is complete.

A second type of rapid prototyping called *solid object 3-D printing* uses an approach similar to inkjet printing. During the build process, a print head with hundreds of jets builds models by dispensing a thermoplastic material in layers. The printer can be networked to any CADD workstation and operates with the push of a few buttons (see Figure 4.69). Chapter 25 provides additional RP coverage related to the engineering design process.



**FIGURE 4.68** The stereolithography system builds a physical prototype, layer by layer, using liquid epoxy plastic that is hardened by laser to precise specifications. Courtesy 3D Systems Corporation

## TOOL DESIGN

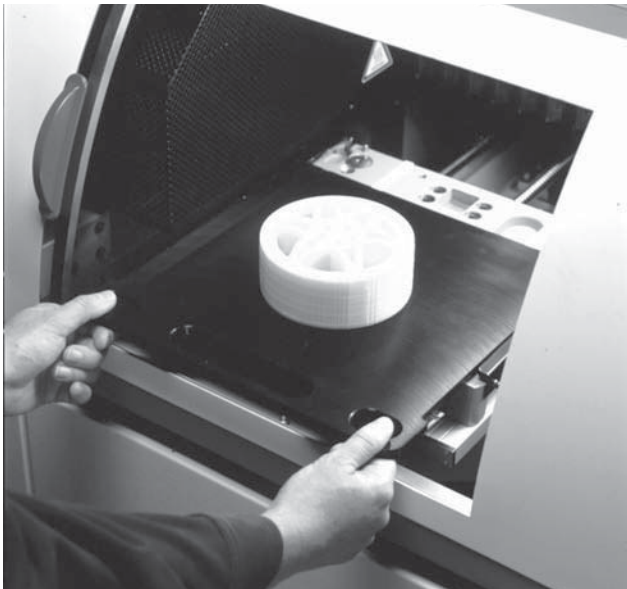
In most production machining operations, special tools are required to either hold the workpiece or guide the machine tool. **Tool design** involves knowledge of kinematics (study of mechanisms) discussed in Chapter 16, machining operations, machine tool function, material handling, and material characteristics. Tool design is also known as **jig** and **fixture** design. In mass-production industries, jigs and fixtures are essential to ensure that each part is produced quickly and accurately within the dimensional specifications. These tools are used to hold the workpiece so that machining operations are performed in the required positions. Application examples are shown in Figure 4.70. Jigs are either fixed or moving devices that are used to hold the workpiece in position and guide the cutting tool. Fixtures do not guide the cutting tool but are used in a fixed position to hold the workpiece. Fixtures are often used in the inspection of parts to ensure that the part is held in the same position each time a dimensional or other type of inspection is made.

Jig and fixture drawings are prepared as an assembly drawing in which all of the components of the tool are shown as if they are assembled and ready for use, as shown in

Figure 4.71. Assembly drawings are discussed in Chapter 20. Components of a jig or fixture often include such items as fast-acting clamps, spring-loaded positioners, clamp straps, quick-release locating pins, handles, knobs, and screw clamps. Normally the part or workpiece is drawn in position



(a)



(b)

using phantom lines in a color such as red or in a combination of phantom lines and color. Additional coverage is provided in Chapter 10, *Dimensioning and Tolerancing*.

## COMPUTER-INTEGRATED MANUFACTURING (CIM)

Completely automated manufacturing systems combine CADD, CAE, and CAM into a controlled system known as **computer-integrated manufacturing (CIM)**. In Figure 4.72, CIM brings together all the technologies in a management system, coordinating CADD, CAM, CNC, robotics, and material handling from the beginning of the design process through the packaging and shipment of the product. The computer system is used to control and monitor all the elements of the manufacturing system. Before a more complete discussion of the CIM systems, it is a good idea to define some of the individual elements. Additional discussion is provided throughout this textbook where applied to specific content.

## Computer-Aided Design and Drafting (CADD)

Engineers and designers use the computer as a flexible design tool. Designs can be created graphically using 3-D models. The effects of changes can be quickly seen and analyzed. Computer-aided drafting is a partner to the design process. Accurate



(c)

**FIGURE 4.69** (a) The 3-D printer uses a print head with hundreds of jets to build models by dispensing a thermoplastic material in layers. (b) A designer removes a model built on a solid object printer. (c) Engineers built this prototype wheel from a CAD file using a solid object printer. *Courtesy 3D Systems*



quality 2-D drawings and 3-D models are created from the designs. Drafting with the computer has increased productivity over manual techniques. The extent of increased productivity depends on the project and skill of the drafter. The computer

has also revolutionized the storage of drawings. There is no longer a need for rooms full of drawing file cabinets. Complete CADD coverage is found in Chapter 3 of this textbook, and the engineering design process is described in Chapter 25.

APPLICATION EXAMPLES

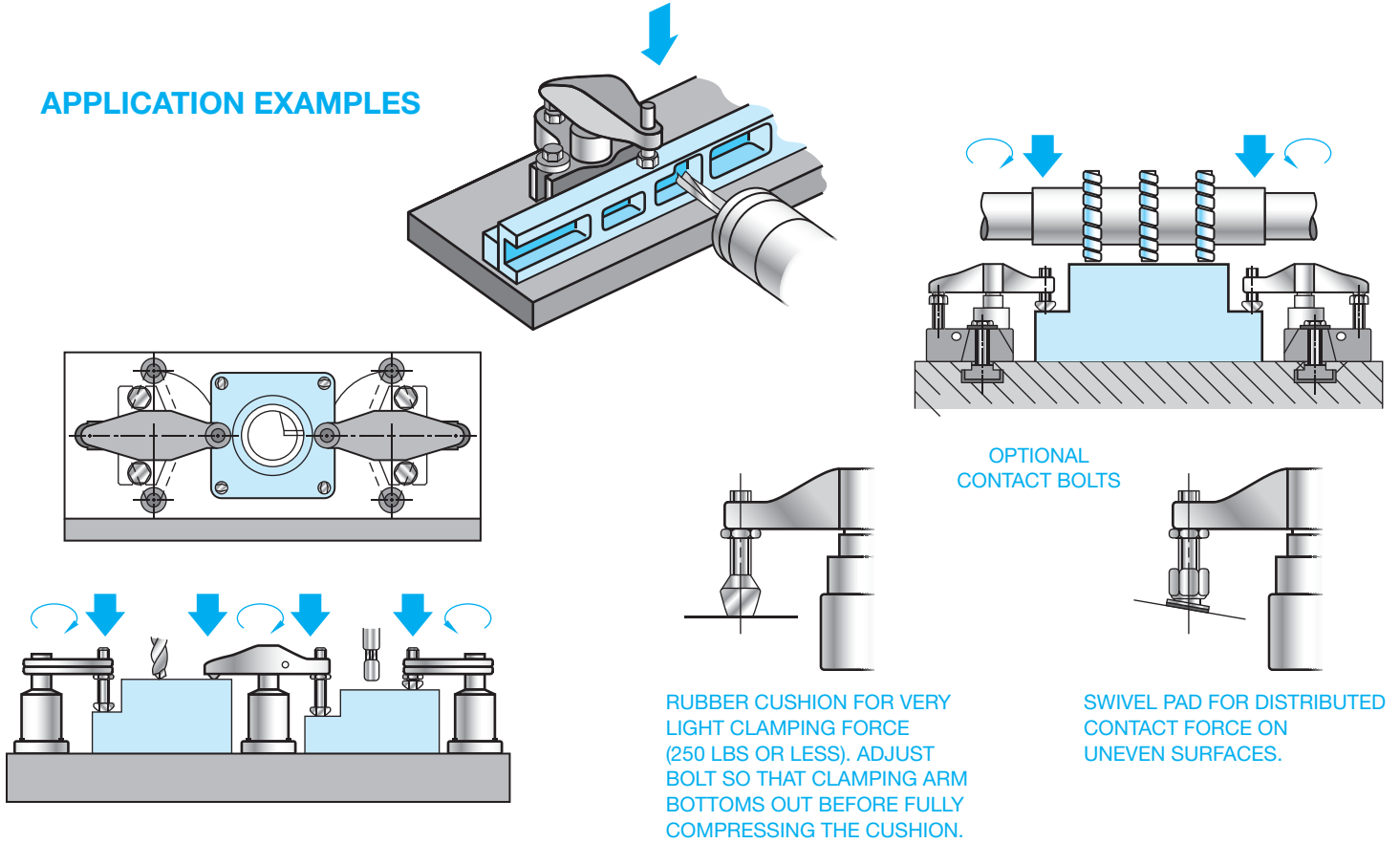


FIGURE 4.70 Fixture application examples. Courtesy Carr Lane Manufacturing Company

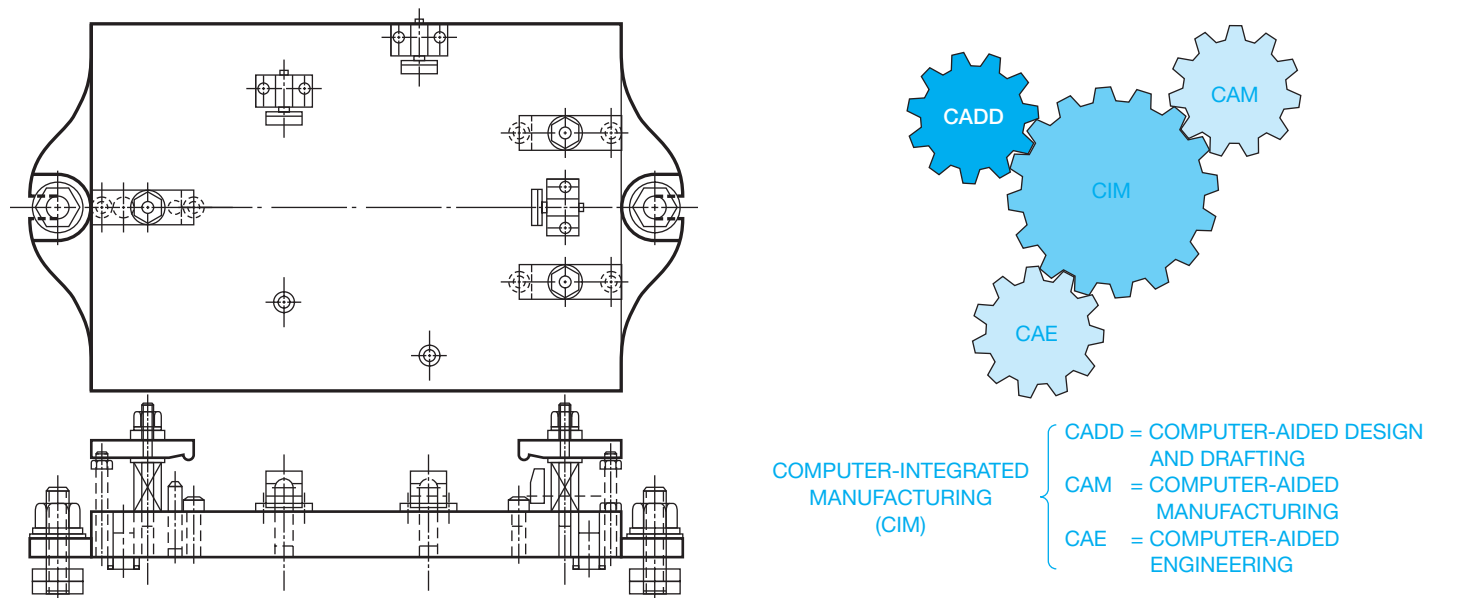


FIGURE 4.71 Fixture assembly drawing. Courtesy Carr Lane Manufacturing Company

FIGURE 4.72 Computer-integrated manufacturing (CIM) is the bringing together of the technologies in a management system. © Cengage Learning 2012

## Computer-Aided Engineering (CAE)

**Computer-aided engineering (CAE)** uses three-dimensional models of the product for **finite element analysis**. This is done in a program in which the computer breaks the model into finite elements, which are small rectangular or triangular shapes. Then the computer is able to analyze each element and determine how it will act under given conditions. It also evaluates how each element acts with the other elements and with the entire model. This allows the engineer to perform experimentation and stress analysis, and make calculations right on the computer. In this manner, engineers can be more creative and improve the quality of the product at less cost. CAE also allows the engineer to simulate function and motion of the product without the need to build a real prototype. In this manner, the product can be tested to see if it works as it should. This process has also been referred to as **predictive engineering**, in which a computer software prototype, rather than a physical prototype, is made to test the function and performance of the product. In this manner, design changes may be made right on the computer screen. Key dimensions are placed on the computer model, and by changing a dimension, you can automatically change the design or you can change the values of variables in mathematical engineering equations to alter the design automatically. Additional CAE and finite element analysis are found in Chapter 25.

## Computer Numerical Control (CNC)

Computer numerical control (CNC) is the use of a computer to write, store, and edit numerical control programs to operate a machine tool. In predictive engineering, a computer software prototype, rather than a physical prototype, is made to test the function and performance of the product. This was discussed in the CADD Applications earlier in this chapter.

## Computer-Aided Manufacturing (CAM)

**Computer-aided manufacturing (CAM)** is a concept that surrounds the use of computers to aid in any manufacturing process. CAD and CAM work best when product programming is automatically performed from the model geometry created during the CAD process. Complex 3-D geometry can be quickly and easily programmed for machining.

## Computer-Aided Quality Control (CAQC)

Information on the manufacturing process and quality control is collected by automatic means while parts are being manufactured; this is the function of **computer-aided quality control (CAQC)**. This information is fed back into the system and compared to the design specifications or model tolerances. This type of monitoring of the mass-production process ensures that the highest product quality is maintained.

## Robotics

According to the Society of Manufacturing Engineers (SME) Robot Institute of America, a **robot** is a reprogrammable multifunctional manipulator designed to move material, parts, tools, or specialized devices through variable programmed motions for the performance of a variety of tasks. This process is called **robotics**. **Reprogrammable** means the robot's operating program can be changed to alter the motion of the arm or tooling. **Multifunctional** means the robot is able to perform a variety of operations based on the program and tooling it uses. Figure 4.73 shows a typical robot.

To make a complete **manufacturing cell**, the robot is added to all of the other elements of the manufacturing process. A manufacturing cell is a group of different machine doing work on products that have similar shapes and processing requirements. The other elements of the cell include the computer controller, robotic program, tooling, associated machine tools, and material-handling equipment.

**Closed-loop (servo)** and **open-loop (nonservo)** are the two types of control used to position the robot tooling. The robot is constantly monitored by position sensors in the closed-loop system. The movement of the robot arm must always conform to the desired path and speed. Open-loop robotic systems do not constantly monitor the position of the tool while the robot arm is moving. The control happens at the end of travel, where limit controls position the accuracy of the tool at the desired place.

## The Human Factor

The properly operating elements of the CIM system provide the best manufacturing automation available. What has been described in this discussion might lead you to believe that the system can be set up and turned on, and the people can go home.



**FIGURE 4.73** A typical robot. Courtesy of Milacron LLC

Not so. An important part of CIM is the human element. People are needed to handle the many situations that happen in the manufacturing cell. The operators constantly observe the machine operation to ensure that material is feeding properly and quality is maintained. In addition to monitoring the system, people load raw material into the system, change machine tools when needed, maintain and repair the system as needed, and handle the completed work when the product is finished.

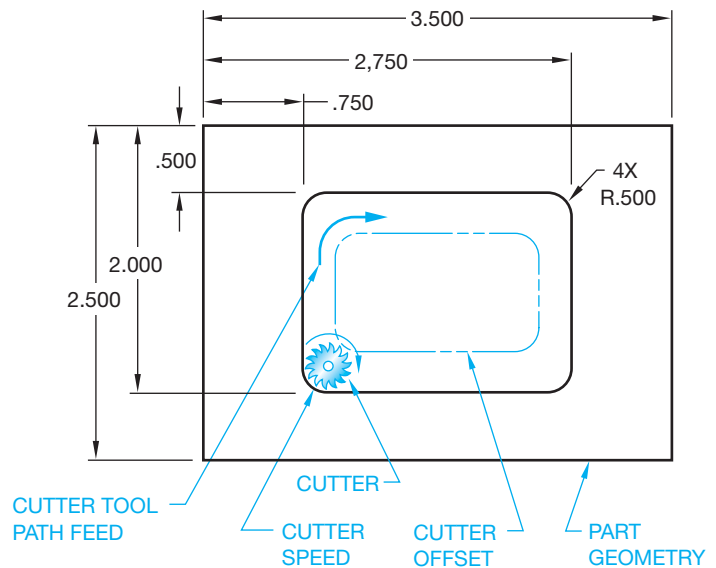
## INTEGRATION OF COMPUTER-AIDED DESIGN AND COMPUTER-AIDED MANUFACTURING (CAD/CAM)

Computer-aided design (CAD) and computer-aided manufacturing (CAM) can be set up to create a direct link between the design and manufacture of a product. The CAD program is used to create the product geometry. This can be in the form of 2-D multiview drawings as discussed in Chapter 8, *Multiviews*, or as 3-D models as explained in Chapter 3 *Computer-Aided Design and Drafting (CADD)*. The drawing geometry is then used in the CAM program to generate instructions for the CNC machine tools employing stamping, cutting, burning, bending, and other types of operations discussed throughout this chapter. This is commonly referred to as CAD/CAM integration. The CAD and CAM operations can be performed on the same computer, or the CAD work can be done at one location and the CAM program can be created at another location. If both the design and manufacturing are done within the company at one location, then the computers can be linked through the local area network. If the design is done at one location and the manufacturing at another, then the computers can be linked through the Internet, or files can be transferred with portable media.

CAD/CAM is commonly used in modern manufacturing because it increases productivity over conventional manufacturing methods. The CAD geometry or model is created during the design and drafting process and is then used directly in the CAM process for the development of the CNC programming. The coordination can also continue into computerized quality control.

The CAD/CAM integration process allows the CAM program to import data from the CAD software. The CAM program then uses a series of commands to instruct CNC machine tools by setting up tool paths. The tool path includes the selection of specific tools to accomplish the desired operation. This can also include specifying tool feed rates and speeds, selecting tool paths and cutting methods, activating tool jigs and fixtures, and selecting coolants for material removal. Some CAM programs automatically calculate the tool offset based on the drawing geometry. Figure 4.74 shows an example of tool offset. CAM programs such as SurfCAM, SmartCAM, and MasterCAM directly integrate the CAD drawing geometry from programs such as AutoCAD and SolidWorks as a reference. The CAM programmer then establishes the desired tool and tool path. The final CNC program is generated when the postprocessor is run. A **postprocessor** is an integral piece of software that converts a generic, CAM-system tool path into usable CNC machine code (G-code).

The **CNC program** is a sequential list of machining operations in the form of a code that is used to machine the part as needed. Typically known as G&M code, these codes invoke



**FIGURE 4.74** The machine tool cutter, tool path, cutter speed, and cutter offset. © Cengage Learning 2012

preparatory functions and control tool and machine movement, spindle speed and direction, and other operations such as clamping, part manipulation, and on-off switching. The machine programmer is trained to select the proper machine tools. A separate tool is used for each operation. These tools can include milling, drilling, turning, threading, and grinding. The CNC programmer orders the machining sequence, selects the tool for the specific operation, and determines the tool feed rate and cutting speed depending on the material.

CAM software programs such as SurfCAM and MasterCAM increase productivity by assisting the CNC programmer in creating the needed CNC code. CAD drawings from programs such as AutoCAD or solid models from software such as Autodesk Inventor and SolidWorks can be transferred directly to the CAM program. The following sequence of activities is commonly used to prepare the CAD/CAM integration:

1. Create the part drawing or model using programs such as AutoCAD, Autodesk Inventor, or SolidWorks. However, programmers commonly originate the model in the CAD/CAM software, such as MasterCAM or SurfCAM.
2. Open the CAD file in the CAM program.
3. Run the CAM software program such as SurfCAM or MasterCAM to establish the following:
  - Choose the machine or machines needed to manufacture the part.
  - Select the required tooling.
  - Determine the machining sequence.
  - Calculate the machine tool feed rates and speeds based on the type of material.
  - Verify the CNC program using the software's simulator.
  - Create the CNC code.
4. Prove out the program on the CNC machine tool.
5. Run the program to manufacture the desired number of parts.

## STATISTICAL PROCESS CONTROL (SPC)

A system of quality improvement is helpful to anyone who turns out a product or engages in a service and who wants to improve the quality of work while increasing the output, all with less labor and at reduced cost. Competition is here to stay, regardless of the nature of the business. Improved quality means less waste and less rework, resulting in increased profits and an improved market position. High quality is an important criterion in customers' purchase decisions. In addition, poor quality is expensive. Regardless of the goods or service produced, it is always less costly to do it right the first time. Improved quality improves productivity, increases sales, reduces cost, and improves profitability. The net result is continued business success.

Traditionally, a type of quality control and quality detection system has been used in most organizations in the United States. This system comprises customer demand for a product, which is then manufactured in a process made up of a series of steps or procedures. Input to the process includes machines, materials, workforce, methods, and environment, as shown in Figure 4.75. Once the product or service is produced, it goes on to an inspection operation where decisions are made to ship, scrap, rework, or otherwise correct any defects when discovered (if discovered). In actuality, if nonconforming products are being produced, then some are being shipped. Even the best inspection process screens out only a portion of the defective goods. Problems inherent in this system are that it does not work very well and is costly. American businesses have become accustomed to accepting these limitations as the **costs of doing business**.

The most effective way to improve quality is to alter the production process—the system—rather than the inspection process. This entails a major shift in the entire organization from the detection system to a prevention mode of operation. In this system, the elements of inputs, process, product or service, customer remain the same, but the inspection method is significantly altered or eliminated. A primary difference between the two systems is that in the prevention system, statistical techniques and problem-solving tools are used to monitor, evaluate, and provide guidance for adjusting the process to improve quality. **Statistical process control (SPC)** is a method of monitoring

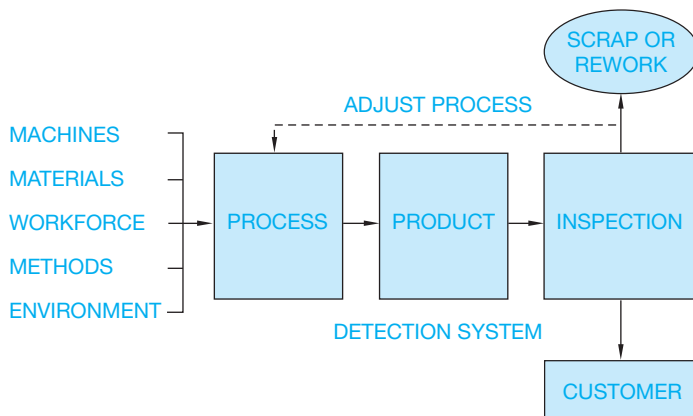


FIGURE 4.75 Quality control/detection system. © Cengage Learning 2012

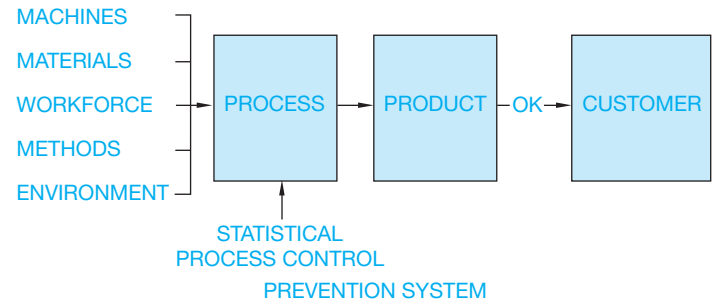


FIGURE 4.76 Quality control/prevention system. © Cengage Learning 2012

a process quantitatively and using statistical signals to either leave the process alone or change it (see Figure 4.76). SPC involves several fundamental elements:

1. The process, product, or service must be measured. It can be measured using either **variables** (a value that varies) or **attributes** (a property or characteristic) from the data collected. The data should be collected as close to the process as possible. If you are collecting data on a particular dimension of a manufactured part, then it should be collected by the machinist who is responsible for holding that dimension.
2. The data can be analyzed using control charting techniques. **Control charting techniques** use the natural variation of a process, determining how much the process can be expected to vary if the process is operationally consistent. The control charts are used to evaluate whether the process is operating as designed or if something has changed.
3. Action is taken based on signals from the control chart. If the chart indicates that the process is in control (operating consistently), then the process is left alone at this point. On the other hand, if the process is found to be out of control (changing more than its normal variability allows), then action is taken to bring it back into control. It is also important to determine how well the process meets specifications and how well it accomplishes the task. If a process is not in control, then its ability to meet specifications is constantly changing. Process capability cannot be evaluated unless the process is in control. Process improvement generally involves changes to the process system that will improve quality or productivity or both. Unless the process is consistent over time, any actions to improve it can be ineffective.

Manufacturing quality control often uses computerized monitoring of dimensional inspections. When this is done, a chart is developed that shows feature dimensions obtained at inspection intervals. The chart shows the expected limits of sample averages as two dashed parallel horizontal lines as shown in Figure 4.77. It is important not to confuse control limits with tolerances—they are not related to each other. The control limits come from the manufacturing process as it is operating. For example, if you set out to make a part  $1.000 \pm .005$  in., and you start the run and periodically take five samples and plot the averages ( $\bar{x}$ ) of the samples, then the sample averages will vary less than the individual parts. The control limits represent the expected

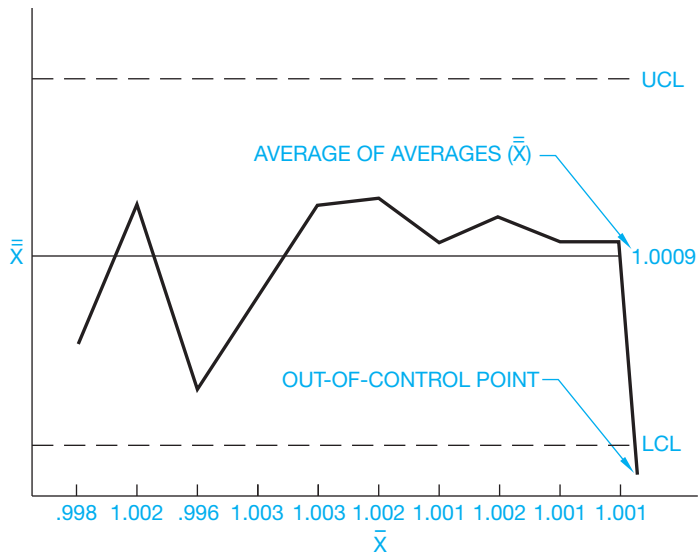


FIGURE 4.77 Quality control chart. © Cengage Learning 2012

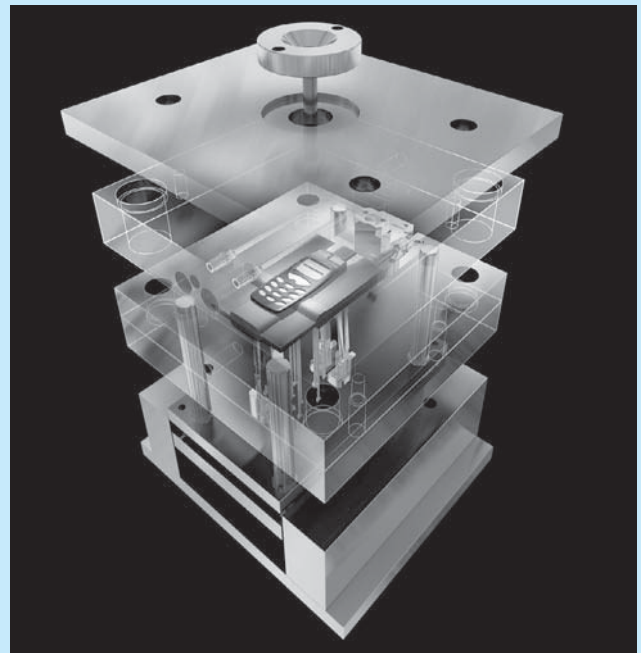
variation of the sample averages if the process is stable. If the process shifts or a problem occurs, then the control limits signal that change. Notice in Figure 4.77 that the  $\bar{x}$  values represent the average of each five samples;  $\bar{\bar{x}}$  is the average of averages over a period of sample taking. The **upper control limit (UCL)** and the **lower control limit (LCL)** represent the expected variation of the sample averages. A sample average can be “out of control” yet remain within tolerance. During this part of the monitoring process, the out-of-control point represents an individual situation that may not be a problem; however, if samples continue to be measured out of control limits, then the process is out of control (no longer predictable) and therefore can be producing parts outside the specification. Action must then be taken to bring the process back into statistical control, or 100% inspection must be resumed. The SPC process only works when a minimum of 25 sample means are in control. When this process is used in manufacturing, part dimensions remain within tolerance limits and parts are guaranteed to have the quality designed.

## MANUFACTURING PROCESSES

Solid modeling software programs can be used to simulate actual manufacturing processes. The 3-D, systematic procedures used to generate a model closely resemble the virtual manufacturing of a product from the initial stages of manufacturing to the finished design. The entire design and manufacturing process can be modeled before any machines are used to manufacture parts and assemblies. In addition, many modeling programs and add-in applications contain specialized tools and options for replicating specific manufacturing tasks. The following information provides a few examples of how manufacturing processes can be simulated using solid modeling software. Adapt the following information as necessary to adhere to your school or company standards.

### Casting and Forging

Standard model feature tools can be used to produce patterns, molds, dies, and complete parts, such as the injection mold and molded products shown in Figure 4.78. However, many programs contain tools for defining specific casting and forging elements such as parting lines and draft angles. Other applications incorporate specialized casting and forging commands that greatly enhance the ability to quickly and accurately model patterns, molds, cores, and dies and account for the shrinkage rates of materials.



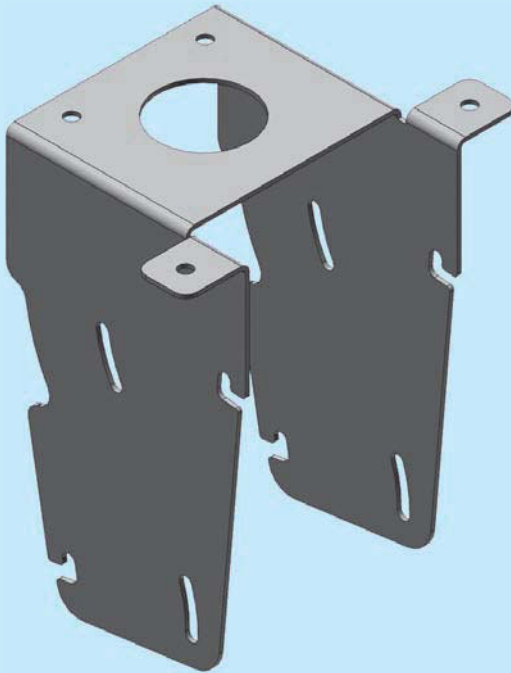
Courtesy Autodesk, Inc.

FIGURE 4.78 Standard model feature tools can be used to produce patterns, molds, dies, and complete parts, such as the injection mold shown in this figure to manufacture cellular phone components.

### Metal Forming and Stamping

CADD software can also model the process of forming and stamping metal. Extrusions that cut through features

(Continued)



Courtesy Z-Kool, Inc.

**FIGURE 4.79** An example of a formed sheet metal part model with metal stamps.

are available with most modeling programs and can be used to produce stamped metal parts. Some software also includes dedicated sheet metal stamping and forming tools that closely replicate the actual process of stamping and forming metal as well as accounting for bend radii, bend allowance, and K factors for different materials. Bend radii, bend allowance, and the K factor are described in detail in Chapter 19, *Precision Sheet Metal Drafting*. An example of a stamped metal part model is shown in Figure 4.79. Chapter 19 provides more information about how CADD is used to model sheet metal products.

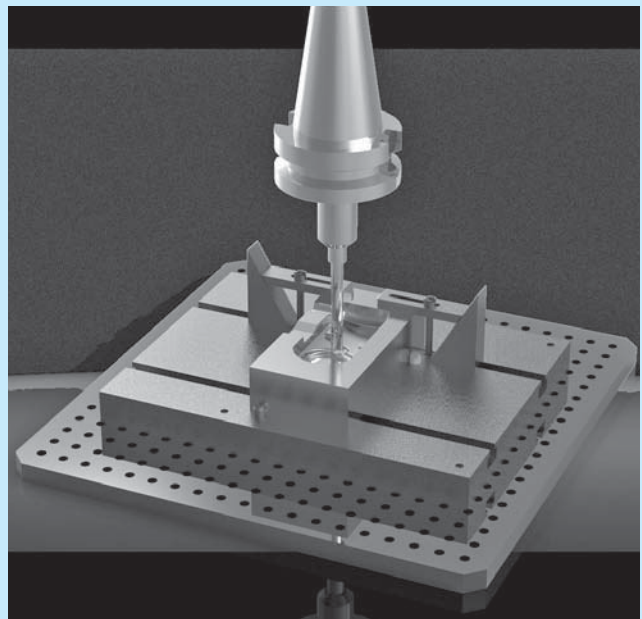
### Machine Processes

Solid modeling applications can model multiple machining processes. For example, the part shown in Figure 4.80 was modeled using a revolved feature tool. Revolutions are ideal for simulating the use of a lathe to manufacture a product. Other examples include adding basic features such as rounds and chamfers to replicate using a grinding or milling machine, as well as drilling holes using modeling tools that allow you to define the exact characteristics of a drilling operation. Figure 4.81 shows a model of a vertical milling machine cutting material from a mold.



© Cengage Learning 2012

**FIGURE 4.80** An example of a revolved feature that will be manufactured using a lathe. This part was modeled using a revolved feature tool. Revolutions are ideal for simulating the use of a lathe to manufacture a product.



**FIGURE 4.81** A solid model showing a vertical milling machine operation. *Courtesy PTC*

## GREEN TECHNOLOGY APPLICATION

Many products are made using recycled materials. You may need to use the universal recycle symbol if you are involved in the design and drafting of products manufactured with recycled materials or packaging made of recycled materials. Figure 4.82 shows one example of the recycle symbol. The symbol can be filled in or drawn as an outline.



© Cengage Learning 2012

FIGURE 4.82 Typical recycling symbol.

## PROFESSIONAL PERSPECTIVE

Mechanical drafting and manufacturing are very closely allied. The mechanical drafter should have a general knowledge of manufacturing methods, including machining processes. It is common for the drafter to consult with engineers and machinists regarding the best methods to implement on a drawing from the design to the manufacturing processes. Part of design problem solving is to create a design that is functional, and that can also be manufactured using available technology at a cost that justifies the product. The solutions to these types of concerns depend on how familiar the drafter and designer are with the manufacturing capabilities of the company. For example, if the designer overtolerances a part or feature, the result can be a rejection of the part by manufacturing or an expensive machining operation.

The drafter should also know something about how machining processes operate so that drawing specifications do not call out something that is not feasible to manufacture. The drafter should be familiar with the processes that are used in machine operations so the notes that are placed on a drawing conform to the proper machining techniques. Notes for machining processes are given on a drawing in the same manner they are performed in the shop. For example, the note for a counterbore is given as the diameter and depth of the hole (first process) and then the diameter and depth of the counterbore (second process). In addition, the drafter should know that the specification given will yield the desired result. One interesting aspect of the design drafter's job

is the opportunity to communicate with people in manufacturing and come up with a design that allows the product to be manufactured easily.

Machining processes are expensive, so drawing requirements that are not necessary for the function of the part should be avoided. For example, surface finishes become more expensive to machine as the roughness height decreases, so if a surface roughness of 125 microinches is adequate, then do not use a 32-microinch specification just because you like smooth surfaces. For example, notice the difference between 63- and 32-microinch finishes. A 63-microinch finish is a good machine finish that can be performed using sharp tools at high speeds with extra fine feeds and cuts. Comparatively, the 32-microinch callout requires extremely fine feeds and cuts on a lathe or milling machine and often requires grinding. The 32-microinch finish is more expensive to perform.

In a manufacturing environment in which cost and competition are critical considerations, a great deal of thought must be given to meeting the functional and appearance requirements of a product for the least possible cost. It generally does not take very long for an entry-level drafter to pick up these design considerations by communicating with the engineering and manufacturing departments. Many drafters become designers, checkers, or engineers within a company by learning the product and being able to implement designs based on the company's manufacturing capabilities.

### FINDING MEANS FOR SPC

The following data consists of weekly samplings of a machine making 2 in. bolts. The process is considered out of control if sample averages exceed a UCL of 2.020 in. or are less than an LCL of 1.980 in. In preparing a chart, find  $\bar{\bar{x}}$  for each week and  $\bar{x}$  for the set of four weeks. Was the process out of control during any week?

Week 1	Week 2	Week 3	Week 4
1.970	2.022	1.980	2.003
2.013	2.014	2.001	1.989
2.051	2.011	1.898	1.993
1.993	2.001	1.888	2.019
1.992	2.009	1.979	2.003

**Solution:** In the world of math statistics, a bar over a letter denotes an average (mean). The formula for finding the average of  $\bar{x}$  values is usually written as  $\bar{\bar{x}} = \Sigma x/n$ , where  $x$  is an individual data value and  $n$  is the total number of data values.  $\Sigma$  is the capital Greek letter sigma, which stands for repeated addition. The formula is the mathematical

way of saying to add all the data and then divide by the total number of individual data points. Applying this idea to each week separately:

$$\begin{aligned} \bar{x} \text{ for Week 1} &= (1.970 + 2.013 + 2.051 \\ &\quad + 1.993 + 1.992) \div 5 \\ &= (10.019) \div 5 = 2.0038 \text{ or } 2.004 \end{aligned}$$

Similarly,

$$\bar{x} \text{ for Week 2} = 2.0114 \text{ or } 2.011$$

$$\bar{x} \text{ for Week 3} = 1.9492 \text{ or } 1.949$$

$$\bar{x} \text{ for Week 4} = 2.0014 \text{ or } 2.001$$

$\bar{\bar{x}}$  is the mean of *these means*. It is found by the same method:

$$\begin{aligned} \bar{\bar{x}} &= (2.0038 + 2.0114 + 1.9492 + 2.0014) \div 4 \\ &= 1.99145 \text{ or } 1.991 \end{aligned}$$

The mean for week 3 is lower than the LCL, so the process was out of control, and corrective measures should be taken at the end of that week.

### WEB SITE RESEARCH

Use the following Web sites as a resource to help find more information related to engineering drawing and design and the content of this chapter.

Address	Company, Product, or Service
www.ab.com	Allen-Bradley: industrial electrical controls
www.aise.org	American Institute of Steel Construction
www.allamericanproducts.com	All American Products: tooling components
www.aluminum.org	Aluminum Association
www.americanchemistry.com	American Chemistry Council
www.asme.org	American Society of Mechanical Engineers
www.astm.org	American Society for Testing Materials International: create standards for materials, products
www.azom.com	The A to Z of materials
www.carrlane.com	Carr Lane Manufacturing: tooling components
www.copper.org	Copper Development Association
www.destaco.com	De-Sta-Co Industries: toggle clamps
www.emtec.org	Edison Materials Technology Center: manufacturing materials research
www.ides.com	Plastic materials directory
www.ides.com	IDES Inc.: plastic materials information
www.industrialpress.com	Machinery's Handbook: manufacturing materials, processes, specifications, and data
www.jergensinc.com	Jergens Inc.: tooling components
www.matweb.com	MatWeb: online material property data

(Continued)



www.mcmaster.com	McMaster-Carr Supply Company: industrial supplies
www.mitutoyo.com	Mitutoyo: precision manufacturing devices
www.mjvail.com	M. J. Vail Co., Inc.: wholesale distributor
www.plasticmakeitpossible.com	Plastics Make It Possible Web site
www.reidtool.com	Reid Tool Supply Co.: tooling components
www.stratasy.com	Stratasy Inc.: rapid prototyping
www.wolverinetool.com	Wolverine Tool Co.: heavy-duty toggle clamps
www.world-aluminum.org	International Aluminum Institute
www.worldsteel.org	International Iron and Steel Institute

## Chapter 4

### Chapter 4 Manufacturing Materials and Processes Test



To access the Chapter 4 test, go to the Student CD, select **Chapter Tests and Problems**, and then **Chapter 4**. Answer the questions

with short, complete statements, sketches, or drawings as needed. Confirm the preferred submittal process with your instructor.

### Chapter 4 Manufacturing Materials and Processes Problems

#### INSTRUCTIONS

This chapter is intended as a reference for manufacturing materials and processes. The concepts discussed serve as a basis for further study in following chapters. A thorough understanding of dimensioning practices is necessary before complete manufactured products can be drawn. Problem assignments ranging from basic to complex manufacturing drawings are assigned in the following chapters.

#### Part 1: Problems 4.1 Through 4.14

Provide a brief but complete definition of each of the following terms. Use your own words to describe the appearance of the actual feature and the related drawing used to represent the feature.

- PROBLEM 4.1 Counterbore
- PROBLEM 4.2 Chamfer
- PROBLEM 4.3 Countersink
- PROBLEM 4.4 Counterdrill
- PROBLEM 4.5 Drill (not through the material)
- PROBLEM 4.6 Fillet

- PROBLEM 4.7 Round
- PROBLEM 4.8 Spotface
- PROBLEM 4.9 Dovetail
- PROBLEM 4.10 Kerf
- PROBLEM 4.11 Keyseat
- PROBLEM 4.12 Keyway
- PROBLEM 4.13 T-slot
- PROBLEM 4.14 Knurl

#### Part 2: Problems 4.15 Through 4.50

The following topics require research or visits to industrial sites or both. It is recommended that you research current professional magazines, visit local industries, or interview professionals in the related field. Your reports should emphasize the following:

- Product.
- The process.
- Material selection.
- Special manufacturing considerations.

- The link between manufacturing and engineering.
- Current technological advances.
- Green technology applications.

Select one or more of the topics listed below or as assigned by your instructor and write a report of approximately 500 words for each.

- PROBLEM 4.15 Casting
- PROBLEM 4.16 Forging
- PROBLEM 4.17 Conventional machine shop
- PROBLEM 4.18 Computer numerical control (CNC) machining
- PROBLEM 4.19 Surface roughness
- PROBLEM 4.20 Tool design
- PROBLEM 4.21 Chemical machining
- PROBLEM 4.22 Electrochemical machining (ECM)
- PROBLEM 4.23 Electrodischarge machining (EDM)
- PROBLEM 4.24 Electron beam (EB) machining
- PROBLEM 4.25 Ultrasonic machining
- PROBLEM 4.26 Laser machining
- PROBLEM 4.27 Statistical process control (SPC)
- PROBLEM 4.28 Thermoplastics
- PROBLEM 4.29 Thermosets
- PROBLEM 4.30 Elastomers
- PROBLEM 4.31 Metal stamping
- PROBLEM 4.32 Powder metallurgy
- PROBLEM 4.33 Manufacturing thermoplastic products
- PROBLEM 4.34 Manufacturing thermoset plastic products
- PROBLEM 4.35 Manufacturing composites
- PROBLEM 4.36 Cast iron
- PROBLEM 4.37 Steel

- PROBLEM 4.38 Aluminum
- PROBLEM 4.39 Copper alloys
- PROBLEM 4.40 Precious and other specialty metals
- PROBLEM 4.41 Computer-aided manufacturing (CAM)
- PROBLEM 4.42 Computer-aided engineering (CAE)
- PROBLEM 4.43 Computer-integrated manufacturing (CIM)
- PROBLEM 4.44 Robotics
- PROBLEM 4.45 Computer-aided design
- PROBLEM 4.46 Computer-aided drafting
- PROBLEM 4.47 Manufacturing cell
- PROBLEM 4.48 CAD/CAM integration
- PROBLEM 4.49 Aluminum and steel material selection
- PROBLEM 4.50 Finite element analysis (FAE) used for material selection

## Math Problems

### Part 3: Problems 4.51 Through 4.53

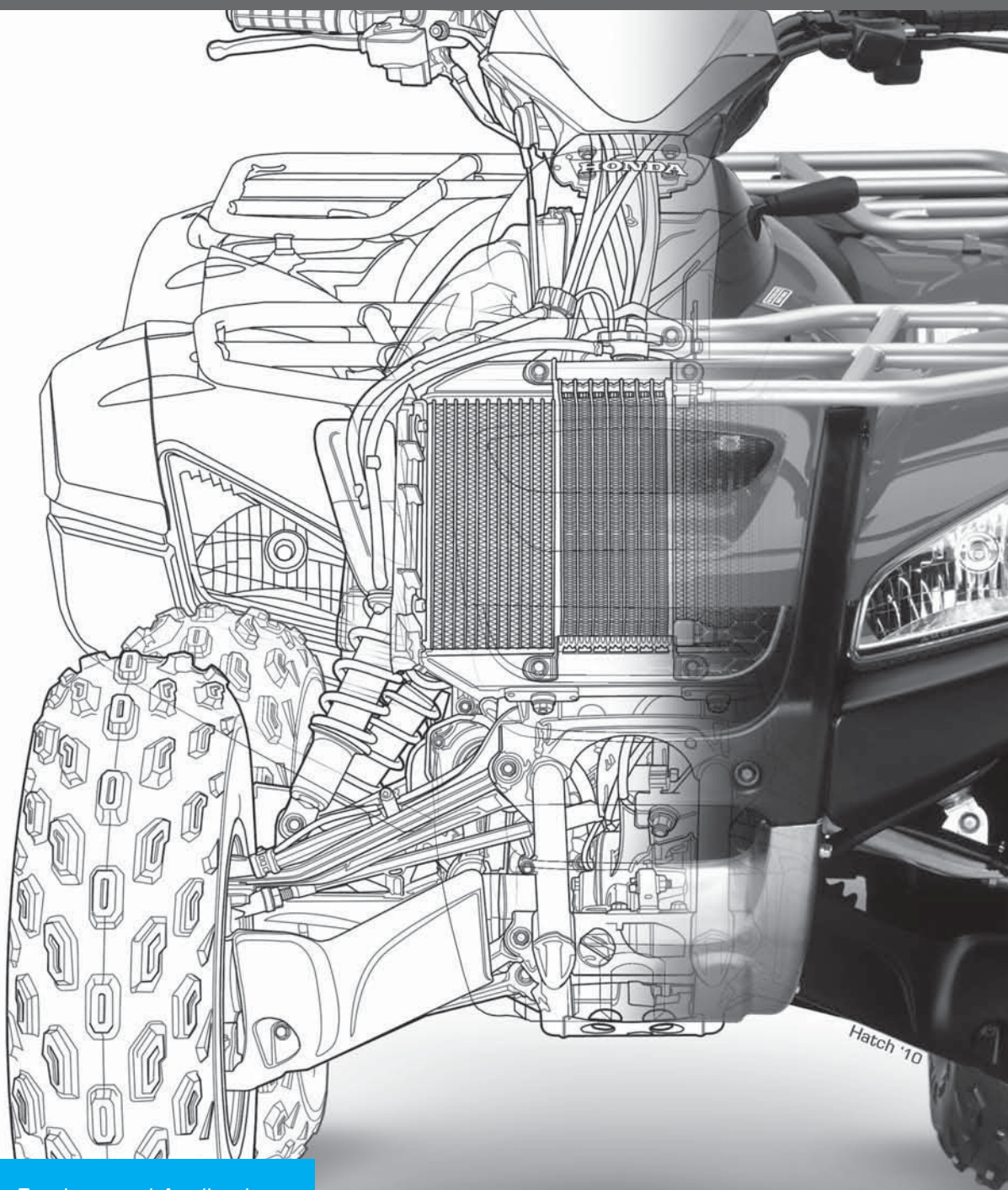
The following is a set of six monthly samples from a process. The UCL is 5.05, and the LCL is 4.95.

Jan	Feb	Mar	Apr	May	Jun
5.06	5.03	5.04	5.04	4.95	4.95
4.94	5.04	5.04	5.07	4.95	4.97
4.99	5.05	5.05	5.05	4.93	4.98
4.99	4.99	5.06	5.02	4.92	5.01
5.00	4.98	5.06	5.00	4.95	5.00

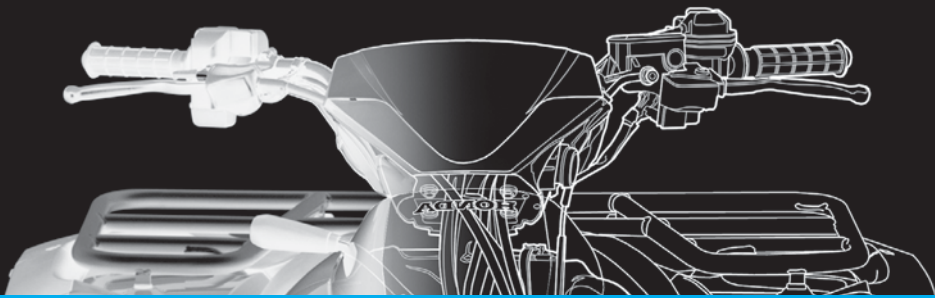
- PROBLEM 4.51 Find  $-\bar{x}$  for each month.
- PROBLEM 4.52 Find  $\bar{\bar{x}}$  for the six-month period.
- PROBLEM 4.53 Conclude whether the process was out of control for any of the months.



# Fundamental Applications



Hatch '10



# CHAPTER 5

## Sketching Applications

### LEARNING OBJECTIVES

After completing this chapter, you will:

- Sketch lines, circles, arcs, and other geometric shapes.
- Sketch multiviews.
- Sketch isometric views.
- Answer questions related to sketching.

## THE ENGINEERING DESIGN APPLICATION

The engineering drafter often works from sketches or written information provided by the engineer. When you receive an engineer's sketch and are asked to prepare a formal drawing, you should follow these steps:

- STEP 1** Prepare a sketch the way you think it should look on the final drawing, taking into account correct drafting standards.
- STEP 2** Evaluate the size of the object so you can determine the scale and sheet size for final CADD layout.
- STEP 3** Lay out the drawing very lightly using construction lines. Construction lines are very lightly

drawn or sketched lines. The construction lines can be easily erased if you make a mistake.

- STEP 4** Complete the final drawing to proper ASME standard line weights. After completion, a check plot can be made on the plotter or printer to check your work on paper or to have another student or your instructor check your work. Sometimes checking a drawing on paper gives you a different perspective than checking it on screen.

The example in Figure 5.1 shows a comparison between a drafter's rough sketch and the finished drawing.

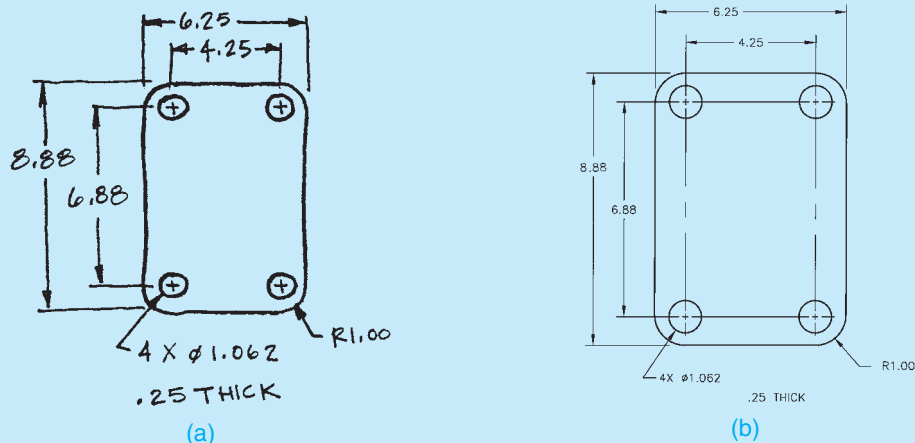


FIGURE 5.1 (a) An engineer's rough sketch. (b) The finished drawing.

© Cengage Learning 2012

### SKETCHING

The ability to communicate ideas through sketch is a fundamental tool for engineers and engineering drafters. Engineers learn early to carry logbooks in which they can document personal and professional activities. A logbook serves several

purposes, including recording your contributions to a product, documenting your research and development giving a timeline, and protecting yourself from professional liability claims. Logbooks provide a place for engineers to sketch ideas and designs. Logbook pages are filled with anything from graphic notes, inspiring clips from magazines, and sketches.

Sketches often are the basis for later detailed drawings of a developing idea. The act of drawing is itself said to be one of the most expressive forms of creativity, acting as an extension of working memory, support for mental imagery, and mental creation. Sketching is a key element of the development process and is used during all the developmental stages of a mechanical design. Sketching is a method of communication used as a tool for problem solving. By practicing and sketching regularly, designers become more creative thinkers. Although CAD has the ability to help solve engineering problems, the computer may not have the same ability to let a designer present a quick idea as easily as with a sketch. Engineering drafters play a key role in a partnership that exists in the design of any manufactured product or construction project. Sketching is used by all involved to quickly communicate ideas plans.

By definition, **sketching** is freehand drawing without the aid of drafting equipment. Sketching is convenient because only paper, pencil, and an eraser are needed. There are a number of advantages and uses for freehand sketching. Sketching is fast visual communication. The ability to make an accurate sketch quickly can often be an asset when communicating with people at work or at home. Especially when technical concepts are the topic of discussion, a sketch can be the best form of communication. Most drafters prepare a preliminary sketch to help organize thoughts and minimize errors on the final drawing. The CADD drafter sometimes prepares a sketch on graph paper to help establish the coordinates for drawing components. Some drafters use sketches to help record the stages of progress when designing, until a final design is ready for formal drawings. A sketch can be a useful form of illustration in technical reports. Sketching is also used in job shops where one-of-a-kind products are made. In the job shop, the sketch is often used as a formal production drawing. When the drafter's assignment is to prepare working drawings for existing parts or products or from prototypes, making a sketch is a good way to gather shape and size descriptions about the project. The sketch can be used to quickly lay out dimensions of features for later transfer to a formal drawing.

The quality of a sketch depends on the intended purpose. Normally, a sketch does not have to be very good quality as long as it adequately represents what you want to display. Speed is a big key to sketching. You normally want to prepare the sketch as quickly as possible while making it as easy and clear to read. Sometimes a sketch does need to have the quality of a formal presentation. It can be used as an artistic impression of a product or as a one-time detail drawing for manufacturing purposes. However, the sketch is normally used in preliminary planning or to relate a design idea to someone very quickly.

The quality of your classroom sketches depends on your course objectives. Your instructor may want quality sketches or very quick sketches that help you establish a plan for further formal drafting. You should confirm this in advance. In the professional world, your own judgment determines the nature and desired quality of the sketch.

## SKETCHING TOOLS AND MATERIALS

Sketching equipment is not very complicated. All you need is paper, pencil, and an eraser. The pencil should have a soft lead. A common number 2 pencil works fine, and an automatic 0.7 or 0.9 mm pencil with F or HB lead is also good. The pencil lead should not be sharp. A dull, slightly rounded pencil point is best. When necessary, different thicknesses of line can be drawn by changing the amount of pressure you apply to the pencil.

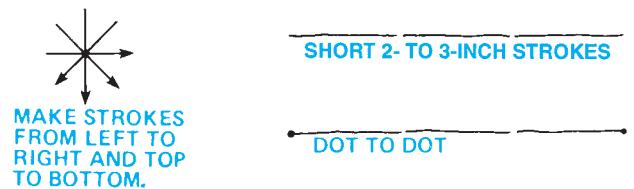
The quality of the paper is also not critical. A good sketching paper is newsprint, although almost any kind of paper works. Paper with a surface that is not too smooth is best. Many engineering designs have been created on a napkin around a lunch table. Sketching paper should not be taped down to the table. The best sketches are made when you are able to move the paper to the most comfortable drawing position. Some people make horizontal lines better than vertical lines. If this is your situation, then move the paper so vertical lines become horizontal. Such movement of the paper is not always possible, so it does not hurt to keep practicing all forms of lines for best results. Graph paper is also good to use for sketching because it has grid lines that can be used as a guide for your sketch lines.

## SKETCHING STRAIGHT LINES

Lines should be sketched in short, light, connected segments as shown in Figure 5.2. If you sketch one long stroke in one continuous movement, your arm tends to make the line curved rather than straight, as shown in Figure 5.3. Also, if you make a dark line, you may have to erase if you make an error. If you draw a light line, there often is no need to erase.

The following is a procedure used to sketch a horizontal straight line using the dot-to-dot method:

- STEP 1** Mark the starting and ending positions, as in Figure 5.4. The letters A and B are only for instruction. All you need is the points.



**FIGURE 5.2** Sketching short line segments. © Cengage Learning 2012



**FIGURE 5.3** Long movements tend to cause a line to curve. © Cengage Learning 2012



**FIGURE 5.4** Step 1: Use dots to identify both ends of a line. © Cengage Learning 2012



FIGURE 5.5 Step 3: Use short light strokes. © Cengage Learning 2012



FIGURE 5.6 Step 4: Darken to finish the line. © Cengage Learning 2012

- STEP 2** Without actually touching the paper with the pencil point, make a few trial motions between the marked points to adjust your eye and hand to the expected line.
- STEP 3** Sketch very light lines between the points by drawing short light 2–3 in. long strokes (50–75 mm). Keep one eye directed toward the end point and the other eye on the pencil point. With each stroke, an attempt should be made to correct the most obvious defects of the preceding stroke so the finished light lines are relatively straight (see Figure 5.5).
- STEP 4** Darken the finished line with a dark, distinct, uniform line directly on top of the light line. Usually the darkness can be obtained by pressing on the pencil (see Figure 5.6).

Very long straight lines can often be sketched by using the edge of the paper or the edge of a table as a guide. To do this, position the paper in a comfortable position with your hand placed along the edge as shown in Figure 5.7a. Extend the pencil point out to the location of the line. Next, place one of your fingers or the palm of your hand along the edge of the paper as a guide. Now, move your hand and the pencil continuously along the edge of the paper as shown in Figure 5.7b. A problem with

this method is that it works best if the line is fairly close to the edge of the paper. A sketch does not have to be perfect anyway, so a little practice should be good enough.

## SKETCHING CIRCULAR LINES

Figure 5.8 shows the parts of a **circle**. There are several sketching techniques to use when making a circle. This text explains the quick freehand method for small circles, the box method, the centerline method, the hand-compass method, and the trammel method for very large circles.

### Sketching Quick Small Circles

Small circles are easy to sketch if you treat them just like drawing the letter O. You should be able to do this in two strokes by sketching a half circle on each side as shown in Figure 5.9.

### Using the Box Method

It is always faster to sketch a circle without first creating other construction guides, but doing so can be difficult. The *box method* can help you by providing a square that contains the desired circle. Start this method by very lightly sketching a square box that is equal in size to the diameter of the proposed circle as shown in Figure 5.10. Next, sketch diagonals across the square. This establishes the center and allows you to mark the radius of the circle on the diagonals as shown in Figure 5.11. Use the sides of the square and the marks on the diagonals as a guide to sketch the circle. Create the circle by drawing arcs that are tangent to the sides of the square and go through the marks on the diagonals as shown in Figure 5.12. If you have trouble sketching the circle as darkly and thickly as desired, then sketch it very lightly first and then go back over it to make it dark. You

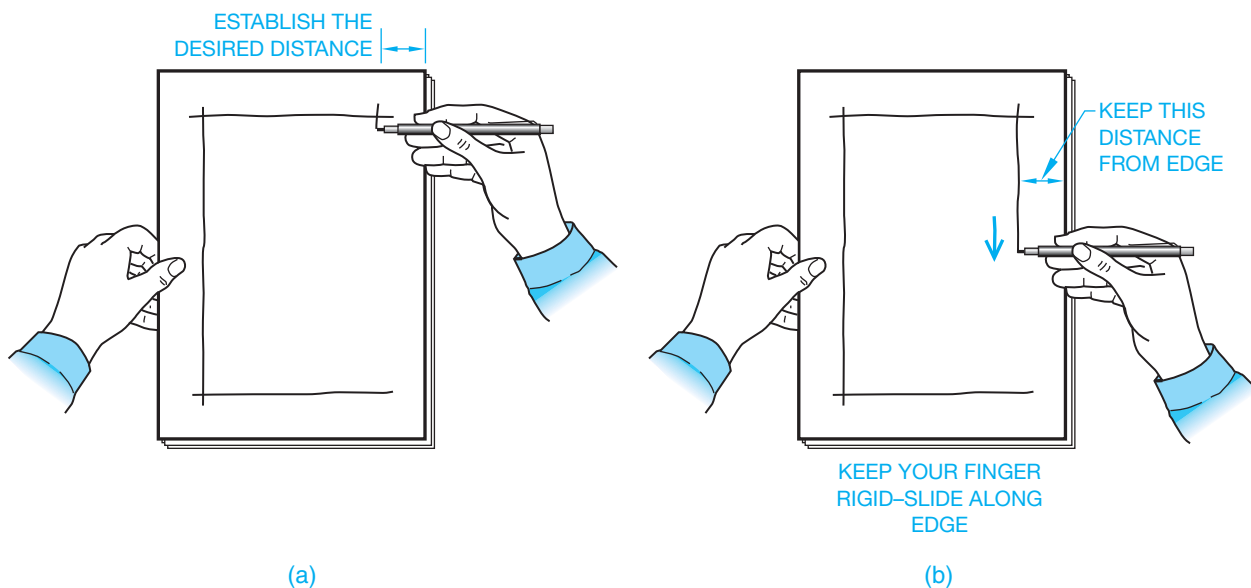


FIGURE 5.7 Sketching very long straight lines using the edge of the sheet as a guide. (a) Place your hand along the edge as a guide. (b) Move your hand and the pencil along the edge of the paper using your finger or palm as a guide to keep the pencil a constant distance from the edge. © Cengage Learning 2012

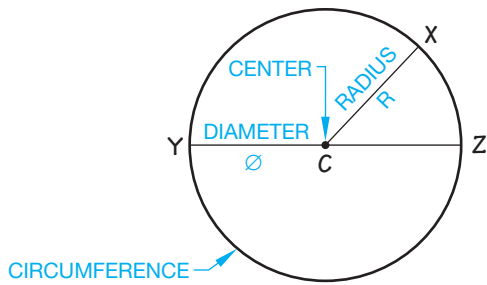


FIGURE 5.8 The parts of a circle.

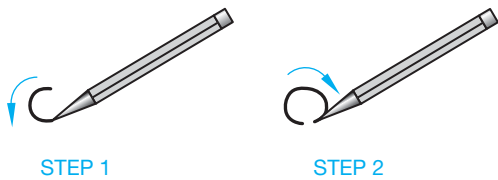


FIGURE 5.9 Sketching a small circle just like drawing the letter O.

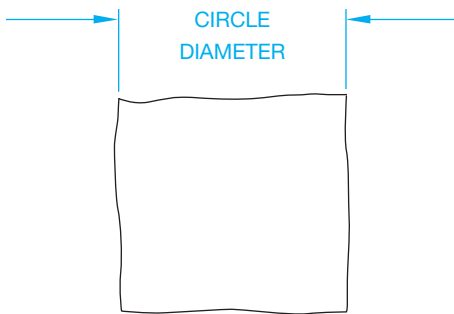


FIGURE 5.10 Very lightly sketch a square box that is equal in size to the diameter of the proposed circle.

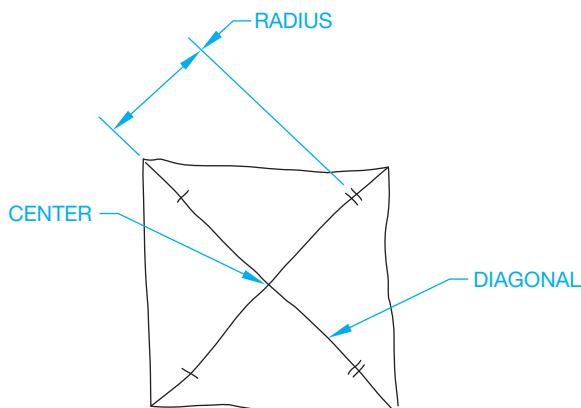


FIGURE 5.11 Sketch light diagonal lines across the square and mark the radius on the diagonals.

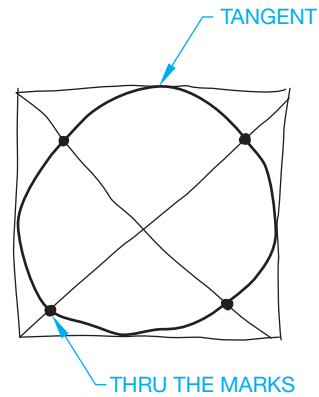


FIGURE 5.12 Create the circle by sketching arcs that are tangent to the sides of the square and go through the marks on the diagonals.

can easily correct very lightly sketched lines, but it is difficult to correct very dark lines. Your construction lines do not have to be erased if they are sketched very lightly.

### Using the Centerline Method

The centerline method is similar to the box method but does not use a box. This method uses very lightly sketched lines—horizontal, vertical, and two 45° diagonals as shown in Figure 5.13. Next, mark the approximate radius of the circle on the centerlines as shown in Figure 5.14. Create the circle by

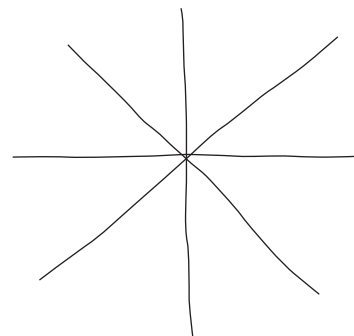


FIGURE 5.13 Sketch very light horizontal, vertical, and 45° lines that meet at the center of the proposed circle.

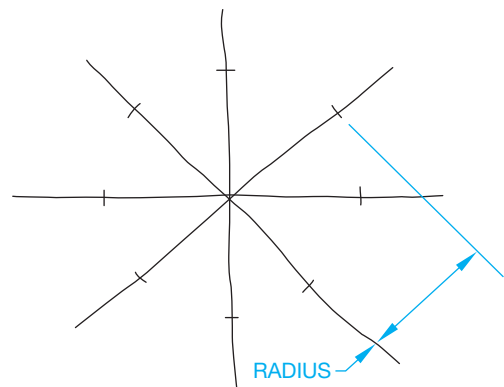
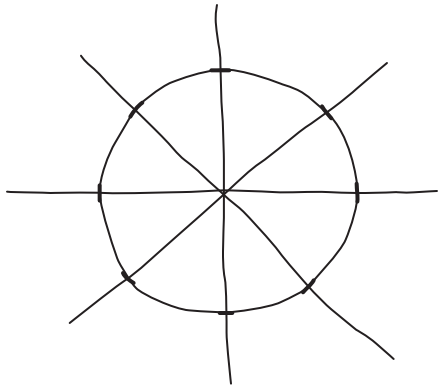


FIGURE 5.14 Mark the approximate radius of the circle on the centerlines created in Figure 5.13.





© Cengage Learning 2012

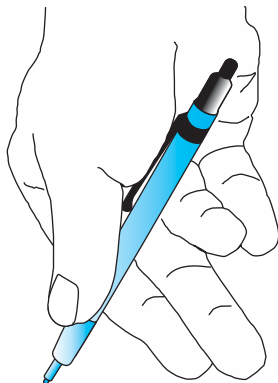
**FIGURE 5.15** Create the circle by sketching arcs that go through the marks on the centerlines.

sketching arcs that go through the marks on the centerlines as shown in Figure 5.15.

### Using the Hand-Compass Method

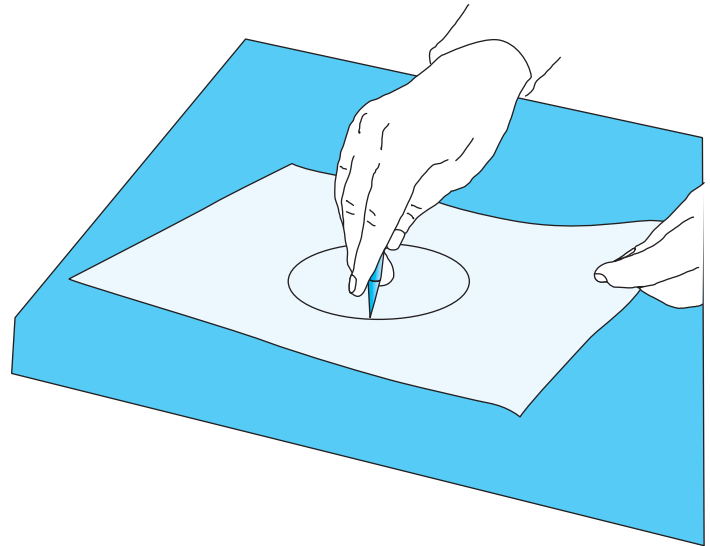
The *hand-compass method* is a quick and fairly accurate method of sketching circles, although it is a method that takes some practice.

- STEP 1** Be sure that your paper is free to rotate completely around 360°. Remove anything from the table that might stop such a rotation.
- STEP 2** To use your hand and a pencil as a compass, place the pencil in your hand between your thumb and the upper part of your index finger so your index finger becomes the compass point and the pencil becomes the compass lead. The other end of the pencil rests in your palm as shown in Figure 5.16.
- STEP 3** Determine the circle radius by adjusting the distance between your index finger and the pencil point. Now, with the desired approximate radius established, place your index finger on the paper at the proposed center of the circle.
- STEP 4** With the desired radius established, keep your hand and pencil point in one place while rotating the paper



© Cengage Learning 2012

**FIGURE 5.16** Step 2: Holding the pencil in the hand compass.



**FIGURE 5.17** Step 4: Rotate the paper under your finger center point.  
© Cengage Learning 2012

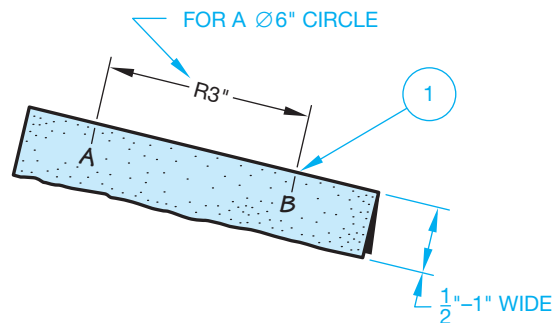
with your other hand. Try to keep the radius steady as you rotate the paper (see Figure 5.17).

- STEP 5** You can perform Step 4 very lightly and then go back and darken the circle or, if you have had a lot of practice, you may be able to draw a dark circle as you go.

### Using the Trammel Method

The *trammel method* should be avoided if you are creating a quick sketch because it takes extra time and materials to set up this technique. Also, the trammel method is intended for large to very large circles that are difficult to draw when using the other methods. The following examples demonstrate the trammel method to create a small circle. This is done to save space. Use the same principles to draw a large circle.

- STEP 1** Make a trammel to sketch a 6 in. (150 mm) diameter circle. Cut or tear a strip of paper approximately 1 in. (25 mm) wide and longer than the radius, 3 in. (75 mm). On the strip of paper, mark an approximate 3 in. radius with tick marks, such as the A and B in Figure 5.18.



© Cengage Learning 2012

**FIGURE 5.18** Step 1: Make a trammel.

- STEP 2** Sketch a straight line representing the circle radius at the place where the circle is to be located. On the sketched line, locate the center of the circle to be sketched with a mark. Use the marks on the trammel to mark the other end of the radius line as shown in Figure 5.19. With the trammel next to the sketched line, be sure point B on the trammel is aligned with the center of the circle you are about to sketch.
- STEP 3** Pivot the trammel at point B, making tick marks at point A as you go, as shown in Figure 5.20, until the circle is complete.
- STEP 4** Lightly sketch the circumference over the tick marks to complete the circle, then darken the circle as in Step 5, if necessary (see Figure 5.21).

Another similar trammel method, generally used to sketch very large circles, is to tie a string between a pencil and a pin. The distance between the pencil and pin is the radius of the circle. Use this method when a large circle is to be sketched because the other methods do not work as well. Workers at a construction site sometimes use this method by tying the string

to a nail and driving the nail at the center location. A carpentry pencil is then tied at the other end of the string to draw a circle on the floor or other construction location.

### SKETCHING ARCS

Sketching arcs is similar to sketching circles. An **arc** is part of a circle as you can see in Figure 5.22. An arc is commonly used as a rounded corner or at the end of a slot. When an arc is a rounded corner, the ends of the arc are typically tangent to adjacent lines. **Tangent** means that the arc touches the line at only one point and does not cross over the line as shown in Figure 5.22. An arc is generally drawn with a radius. The most comfortable way to sketch an arc is to move the paper so your hand faces the inside of the arc. Having the paper free to move helps with this practice.

One way to sketch an arc is to create a box at the corner. The box establishes the arc center and radius as shown in Figure 5.23. You can also sketch a 45° construction line from the center to the outside corner of the box and mark the radius on the 45° line (see Figure 5.23). Now, sketch the arc by using the tangent points and the mark as a guide as shown

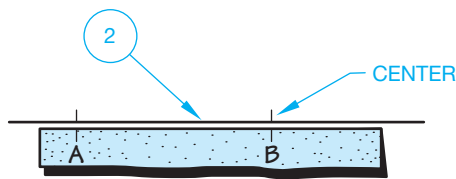


FIGURE 5.19 Step 2: Locate the center of the circle.

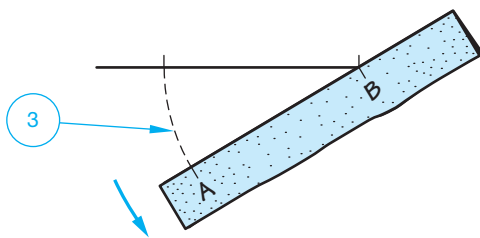


FIGURE 5.20 Step 3: Begin the circle construction.

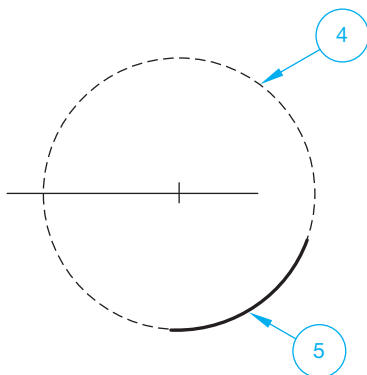


FIGURE 5.21 Steps 4 and 5: Darken the circle.

© Cengage Learning 2012

© Cengage Learning 2012

© Cengage Learning 2012

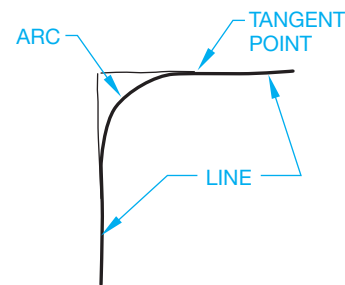


FIGURE 5.22 An arc is part of a circle. This arc is used to create a rounded corner. Notice that the arc creates a smooth connection at the point of tangency with the straight lines.

© Cengage Learning 2012

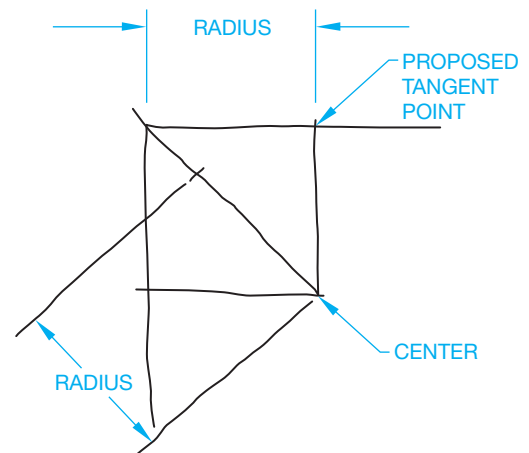
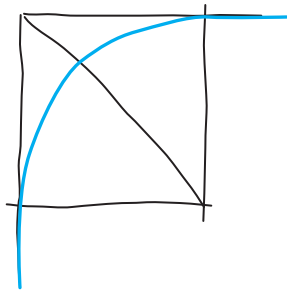


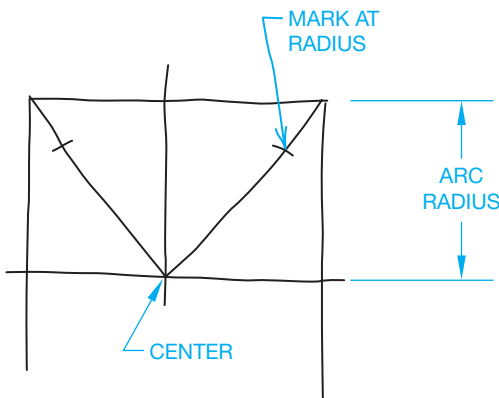
FIGURE 5.23 The box establishes the center and radius of the arc. The 45° diagonal helps establish the radius.

© Cengage Learning 2012

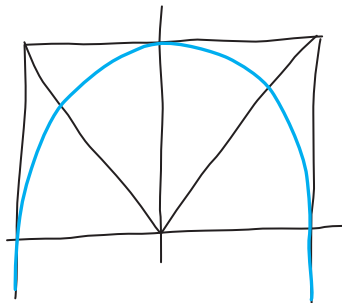


© Cengage Learning 2012

**FIGURE 5.24** Sketch the arc using the tangent points and mark on the diagonal as a guide for the radius.



STEP 1



STEP 2

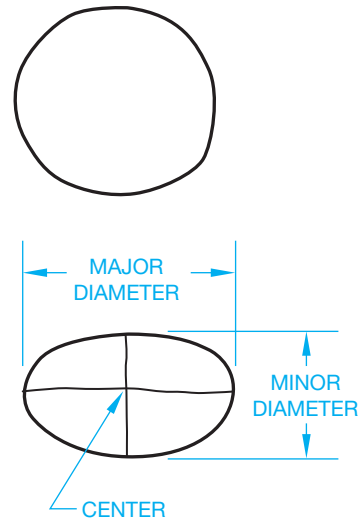
**FIGURE 5.25** Sketching a full radius arc uses the same method as sketching any arc or circle.

in Figure 5.24. You should generally connect the tangent straight lines to the arc after the arc is created because it is usually easier to sketch straight lines than it is to sketch arcs.

The same technique can be used to sketch any arc. For example, a full radius arc is sketched in Figure 5.25. This arc is half of a circle, so using half of the box method or centerline method works well.

## SKETCHING ELLIPSES

If you look directly at a coin, it represents a circle. As you rotate the coin, it takes the shape of an **ellipse**. Figure 5.26 shows the relationship between a circle and an ellipse and also shows the parts of an ellipse.



© Cengage Learning 2012

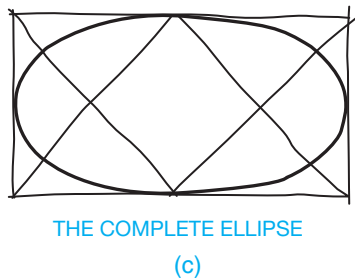
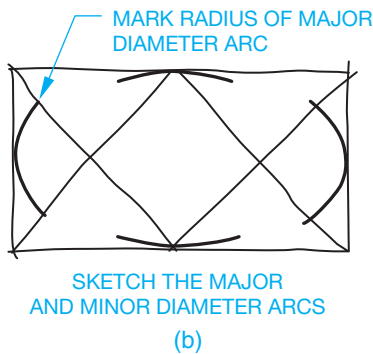
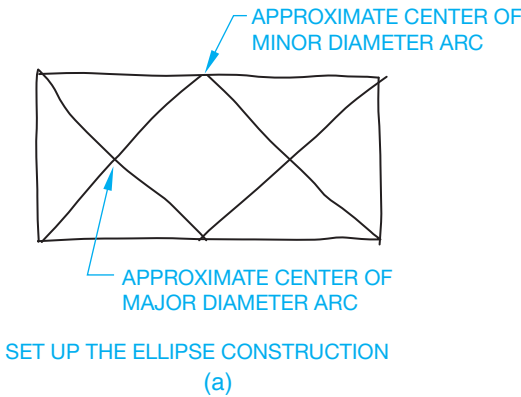
**FIGURE 5.26** The relationship between an ellipse and a circle.

If you can fairly accurately sketch an ellipse without construction lines, then do it. If you need help, an ellipse also can be sketched using a box method. To start this technique, sketch a light rectangle equal in length and width to the major and minor diameters of the desired ellipse as shown in Figure 5.27a. Next, sketch crossing lines from the corners of the minor diameter to the midpoint of the major diameter sides as in Figure 5.27a. Now, using the point where the lines cross as the center, sketch the major diameter arcs (see Figure 5.27b). Use the midpoint of the minor diameter sides as the center to sketch the minor diameter arcs as shown in Figure 5.27b. Finally, blend in connecting arcs to fill the gaps as shown in Figure 5.27c.

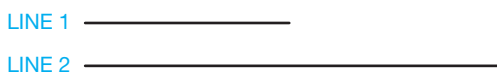
## MEASUREMENT LINES AND PROPORTIONS

When sketching objects, all the lines that make up the object are related to each other by size and direction. In order for a sketch to communicate accurately and completely, it must be drawn in approximately the same proportion as the object. The actual size of the sketch depends on the paper size and how large you want the sketch to look. The sketch should be large enough to be clear, but the proportions of the features are more important than the size of the sketch.

Look at the lines in Figure 5.28 and ask these questions: How long is line 1? How long is line 2? Answer these questions without measuring either line, but instead relate each line to the other. For example, line 1 can be stated as being half as long as line 2, or line 2 is about twice as long as line 1. Now you know how long each line is in relationship to the other. This is referred to as *proportion*. You do not know how long either line is in relationship to a measured scale. No scale is used for sketching, so this is not a concern. Whatever line you decide to sketch first determines the scale of the drawing.

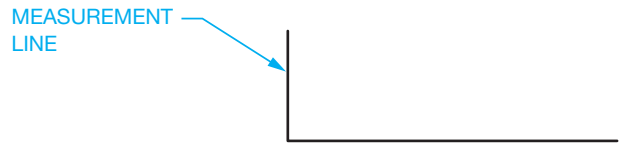


**FIGURE 5.27** Sketching an ellipse. (a) Sketch a light rectangle equal in length and width to the major and minor diameters of the desired ellipse. Sketch crossing lines from the corners of the minor diameter to the midpoint of the major diameter sides. (b) Use the point where the lines cross as the center to sketch the major diameter arcs. Use the midpoint of the minor diameter sides as the center to sketch the minor diameter arcs. (c) Blend in connecting arcs to fill the gaps.

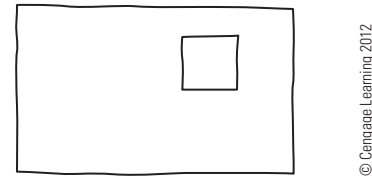


**FIGURE 5.28** Measurement lines. © Cengage Learning 2012

This first line sketched is called the *measurement line*. Relate all the other lines in the sketch to the first line. This is one of the secrets of making a sketch look like the object being sketched.



**FIGURE 5.29** Measurement line. © Cengage Learning 2012



**FIGURE 5.30** Space proportions.

The second thing you must know about the relationship of the two lines in Figure 5.29 is their direction and position relative to each other. For example, do they touch each other? Are they parallel, perpendicular, or at some angle to each other? When you look at a line, ask yourself the following questions using the two lines given in Figure 5.29:

1. How long is the second line?
  - a. Is it the same length as the first line?
  - b. Is it shorter than the first line? How much shorter?
  - c. Is it longer than the first line? How much longer?
2. In what direction and position is the second line related to the first line?

Typical answers to these questions for the lines in Figure 5.29 are as follows:

1. The second line is about three times as long as the first line.
2. Line two touches the lower end of the first line with about a 90° angle between each line.

Carrying this concept a step further, a third line can relate to the first line or the second line and so forth. Again, the first line drawn (measurement line) sets the scale for the entire sketch.

This idea of relationship can also apply to spaces. In Figure 5.30, the location of the square can be determined by space proportions. A typical verbal location for the square in this block might be as follows: The square is located about one-half square width from the top of the object or about two square widths from the bottom, and about one square width from the right side or about three square widths from the left side of the object. All the parts must be related to the whole object.

## INTRODUCTION TO THE BLOCK TECHNIQUE

Any illustration of an object can be surrounded with some sort of an overall rectangle, as shown in Figure 5.31. Before starting a sketch, visualize in your mind the object to be sketched inside a rectangle. Then use the measurement-line technique with the rectangle, or block, to help you determine the shape and proportion of your sketch.

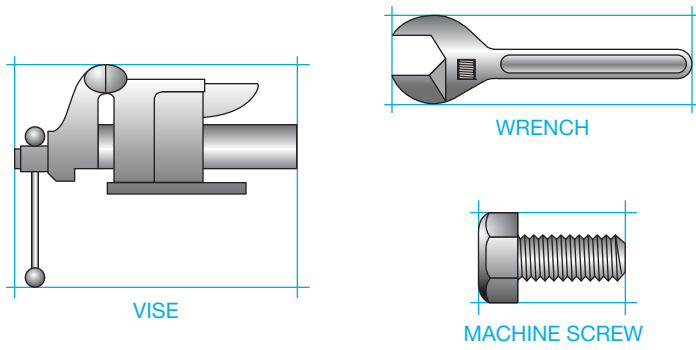


FIGURE 5.31 Block technique. © Cengage Learning 2012

### Procedures for Sketching Objects

- STEP 1** When starting to sketch an object, visualize the object surrounded with an overall rectangle. Sketch this rectangle first with very light lines. Sketch the proper proportion with the measurement-line technique as shown in Figure 5.32.
- STEP 2** Cut out or cut away sections using proper proportions as measured by eye, using light lines as in Figure 5.33.
- STEP 3** Finish the sketch by darkening in the desired outlines for the finished sketch (see Figure 5.34).

### Sketching Irregular Shapes

Irregular shapes can be sketched easily to their correct proportions by using a frame of reference or an extension of the block method. Follow these steps to sketch the cam shown in Figure 5.35.

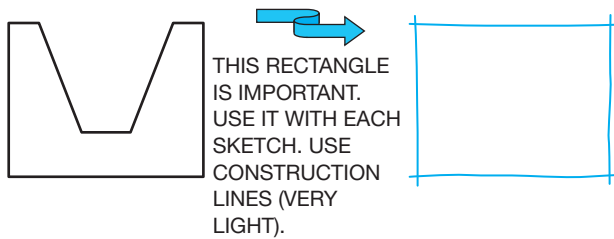


FIGURE 5.32 Step 1: Outline the drawing area with a block.

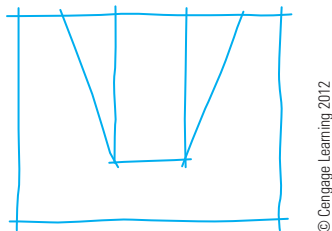


FIGURE 5.33 Step 2: Draw features to proper proportions.

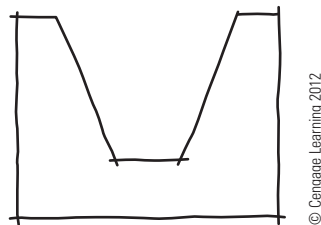


FIGURE 5.34 Step 3: Darken the object lines.

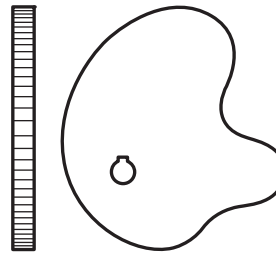


FIGURE 5.35 Cam.

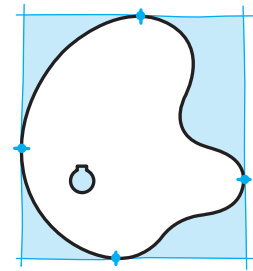


FIGURE 5.36 Step 1: Box the object.

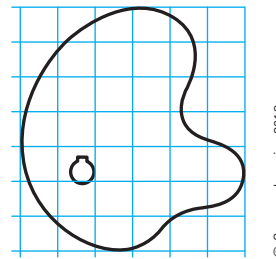


FIGURE 5.37 Step 2: Evenly spaced grid.

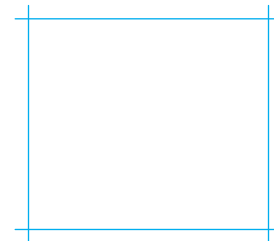


FIGURE 5.38 Step 3: Proportioned box.

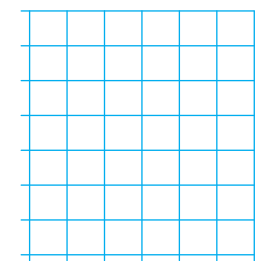


FIGURE 5.39 Step 4: Regular grid.

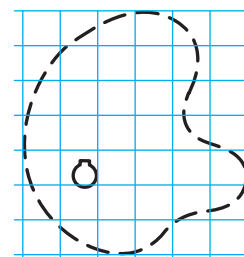
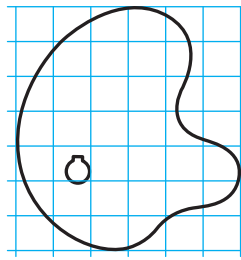


FIGURE 5.40 Step 5: Sketched shape using the regular grid.

- STEP 1** Place the object in a lightly constructed box (see Figure 5.36).
- STEP 2** Draw several equally spaced horizontal and vertical lines as shown in Figure 5.37. If you are sketching an object already drawn, just draw your reference lines on top of the object's lines to establish a frame of reference. If you are sketching an object directly, you have to visualize these reference lines on the object you sketch.
- STEP 3** On your sketch, correctly locate a proportioned box similar to the one established on the original drawing or object as shown in Figure 5.38.
- STEP 4** Using the drawn box as a frame of reference, include the grid lines in correct proportion as seen in Figure 5.39.
- STEP 5** Then, using the grid, sketch the small irregular arcs and lines that match the lines of the original as in Figure 5.40.



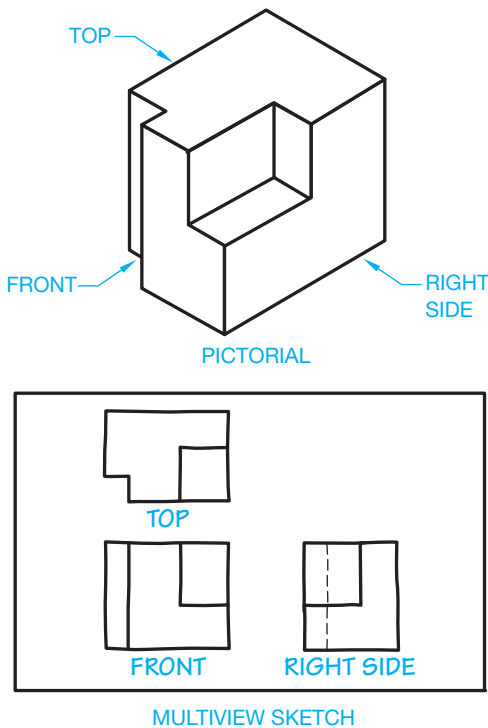
© Cengage Learning 2012

FIGURE 5.41 Step 6: Completely darken the outline of the object.

**STEP 6** Darken the outline for a complete proportioned sketch as shown in Figure 5.41.

### CREATING MULTIVIEW SKETCHES

**Multiview projection** is also known as **orthographic projection**. **Multiviews** are two-dimensional (2-D) views of an object that are established by a line of sight that is perpendicular (90°) to the surface of the object. When making multiview sketches, a systematic order should be followed. Most drawings are in the multiview form. Learning to sketch multiview drawings saves you time when making a formal drawing. The **pictorial view** shows the object in a three-dimensional (3-D) picture, and the multiview shows the object in a 2-D representation. Figure 5.42 shows an object in 3-D and 2-D. Chapter 8 provides complete information about multiviews.



© Cengage Learning 2012

FIGURE 5.42 Views of objects shown in pictorial view and multiview.

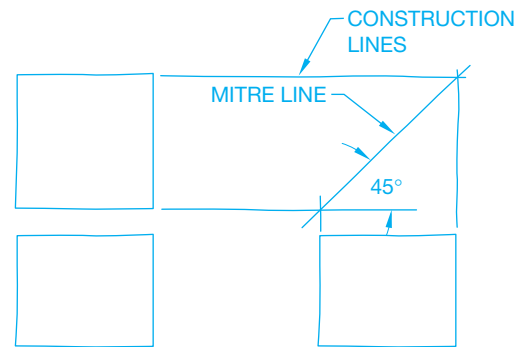
### Multiview Alignment

To keep your drawing in a common form, sketch the front view in the lower left portion of the paper, the top view directly above the front view, and the right-side view directly to the right side of the front view (see Figure 5.42). The views needed may differ, depending on the object. Your ability to visualize between 3-D objects and 2-D views is very important in understanding how to lay out a multiview sketch. Multiview arrangement is explained in detail in Chapter 8.

### Multiview Sketching Technique

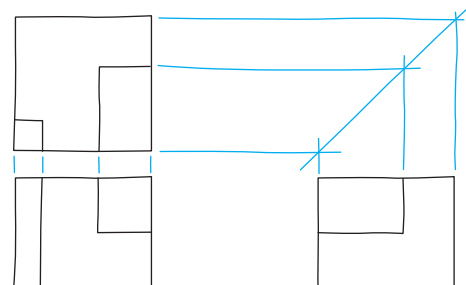
Steps in sketching multiviews:

- STEP 1** Sketch and align the proportional rectangles for the front, top, and right-side views of the object given in Figure 5.42. Sketch a 45° line to help transfer width dimensions. The 45° line is established by projecting the width from the top view across and the width from the right-side view up until the lines intersect as shown in Figure 5.43. This 45° line is often called a *mitre line*.
- STEP 2** Complete the shapes by cutting out the rectangles as shown in Figure 5.44.
- STEP 3** Darken the lines of the object as in Figure 5.45. Remember, keep the views aligned for ease of sketching and understanding.



© Cengage Learning 2012

FIGURE 5.43 Step 1: Block out views.



© Cengage Learning 2012

FIGURE 5.44 Step 2: Block out shapes.

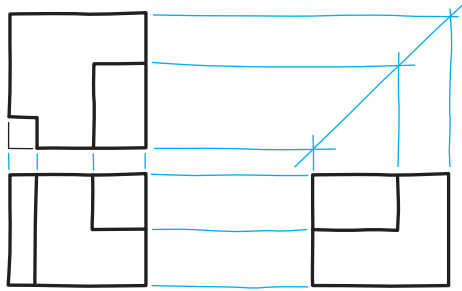


FIGURE 5.45 Step 3: Darken all object lines.

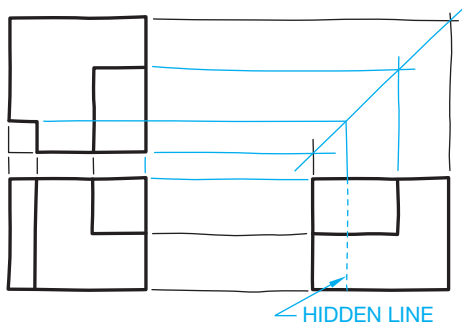


FIGURE 5.46 Step 4: Draw hidden features.

**STEP 4** The views in which some of the features are hidden, show those features with hidden lines, which are dashed lines as shown in Figure 5.46. Start the practice of sketching thick object lines and thin hidden lines.

## CREATING ISOMETRIC SKETCHES

**Isometric sketches** provide a 3-D pictorial representation of an object. Isometric sketches are easy to create and make a very realistic exhibit of the object. The surface features or the axes of the objects are drawn at equal angles from horizontal. Isometric sketches tend to represent the objects as they appear to the eye. Isometric sketches help in the visualization of an object because three sides of the object are sketched in a single 3-D view. Chapter 14 covers isometric drawings in detail.

### Establishing Isometric Axes

When setting up an isometric axis, you need four beginning lines: a horizontal reference line, two 30° angular lines, and one vertical line. Draw them as very light construction lines (see Figure 5.47).

- STEP 1** Sketch a horizontal reference line. This represents the ground-level line.
- STEP 2** Sketch a vertical line perpendicular to the ground line and somewhere near its center. The vertical line is used to measure height.

© Cengage Learning 2012

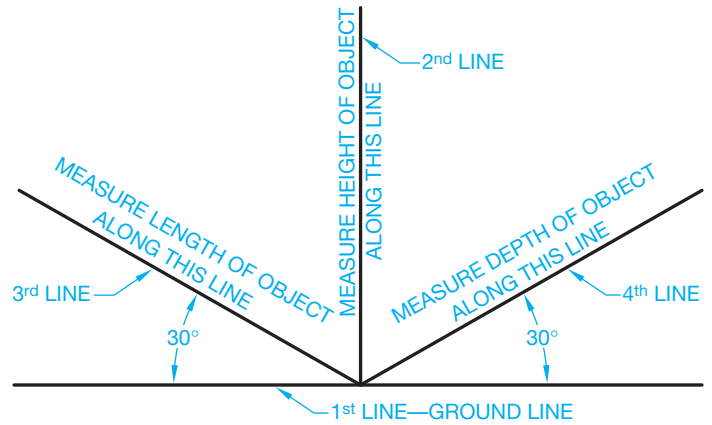


FIGURE 5.47 Isometric axis. © Cengage Learning 2012

**STEP 3** Sketch two 30° angular lines, each starting at the intersection of the first two lines as shown in Figure 5.47.

### Making an Isometric Sketch

The steps in making an isometric sketch are as follows:

- STEP 1** Select an appropriate view of the object.
- STEP 2** Determine the best position in which to show the object.
- STEP 3** Begin your sketch by setting up the isometric axes (see Figure 5.48).
- STEP 4** Using the measurement-line technique, draw a rectangular box, using correct proportion, which could surround the object to be drawn. Use the object shown in Figure 5.49 for this example. Imagine the

© Cengage Learning 2012

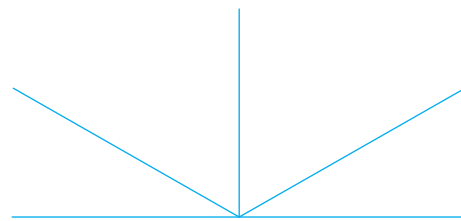


FIGURE 5.48 Step 3: Sketch the isometric axis.

© Cengage Learning 2012

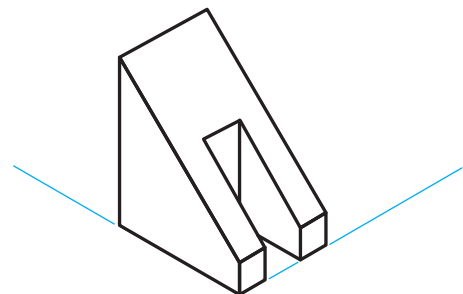


FIGURE 5.49 Given object.

© Cengage Learning 2012

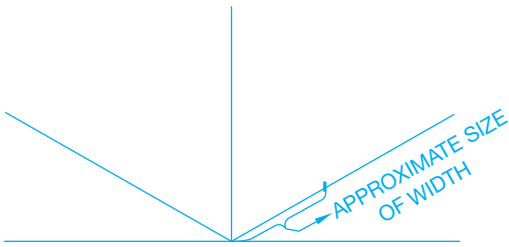


FIGURE 5.50 Step 4: Lay out the width.

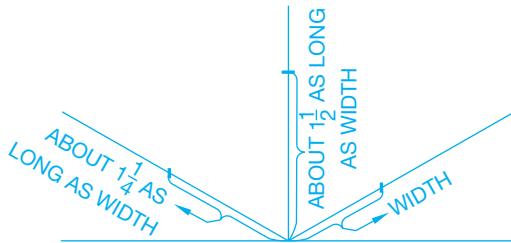


FIGURE 5.51 Step 4: Lay out the length and height.

rectangular box in your mind. Begin to sketch the box by marking off the width at any convenient length as in Figure 5.50. This is your measurement line. Next, estimate and mark the length and height as related to the measurement line (see Figure 5.51). Sketch the 3-D box by using lines parallel to the original axis lines (see Figure 5.52). Sketching the box is the most critical part of the construction. It must be done correctly, otherwise your sketch will be out of proportion. All lines drawn in the same direction must be parallel.

**STEP 5** Lightly sketch the slots, insets, and other features that define the details of the object. By estimating distances on the rectangular box, the features of the object are easier to sketch in correct proportion than trying to draw them without the box (see Figure 5.53).

**STEP 6** To finish the sketch, darken all the object lines (outlines) as in Figure 5.54. For clarity, do not show any hidden lines.

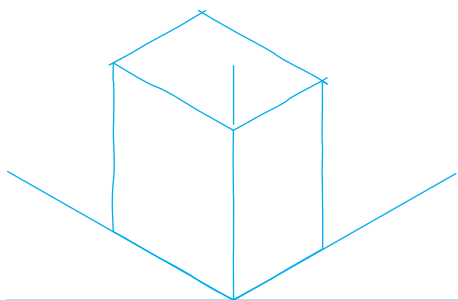


FIGURE 5.52 Step 4: Sketch the 3-D box.

© Cengage Learning 2012

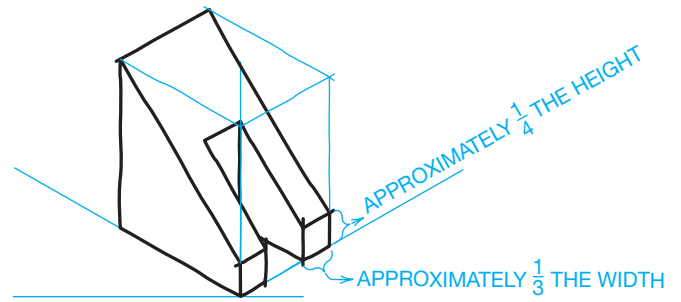


FIGURE 5.53 Step 5: Sketch the features. © Cengage Learning 2012

© Cengage Learning 2012

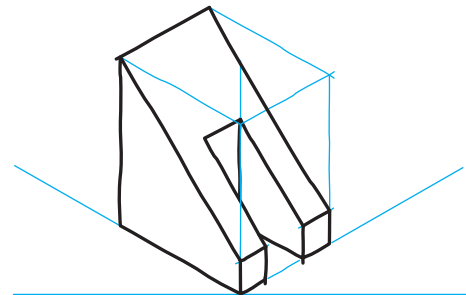


FIGURE 5.54 Step 6: Darken the outline.

© Cengage Learning 2012

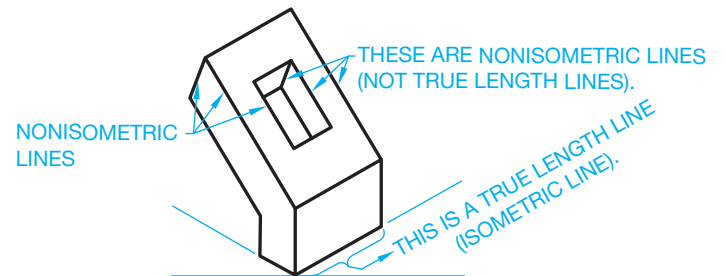


FIGURE 5.55 Nonisometric lines. © Cengage Learning 2012

## Sketching Nonisometric Lines

**Isometric lines** are lines that are on or parallel to the three original isometric axes lines. All other lines are nonisometric lines. Isometric lines can be measured in true length. **Nonisometric lines** appear either longer or shorter than they actually are (see Figure 5.55). You can measure and draw nonisometric lines by connecting their end points. You can find the end points of the nonisometric lines by measuring along isometric lines. To locate where nonisometric lines should be placed, you have to relate to an isometric line. Follow through these steps, using the object in Figure 5.56 as an example.

- STEP 1** Develop a proportional box as in Figure 5.57.
- STEP 2** Sketch in all isometric lines as shown in Figure 5.58.
- STEP 3** Locate the starting and end points for the nonisometric lines (see Figure 5.59).

© Cengage Learning 2012



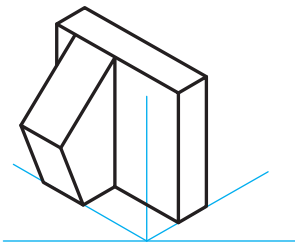


FIGURE 5.56 Guide.

© Cengage Learning 2012

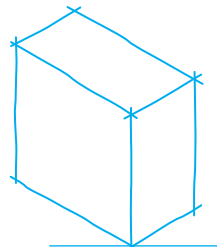


FIGURE 5.57 Step 1: Sketch the box.

© Cengage Learning 2012

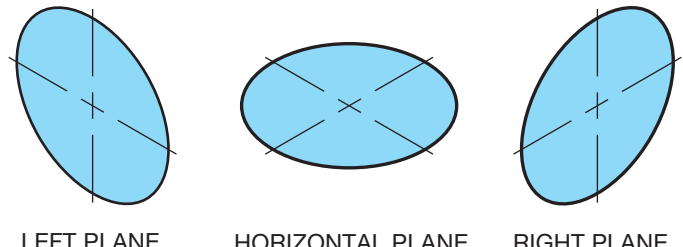


FIGURE 5.61 Isometric circles. © Cengage Learning 2012

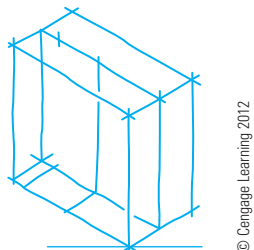


FIGURE 5.58 Step 2: Sketch isometric lines.

© Cengage Learning 2012

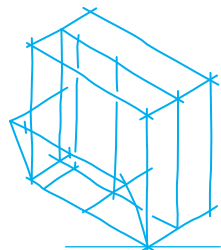


FIGURE 5.59 Step 3: Locate nonisometric line end points.

© Cengage Learning 2012

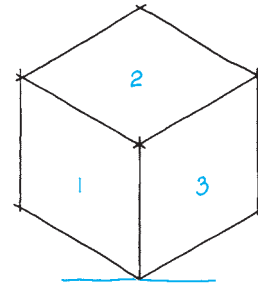


FIGURE 5.62 Step 1: Draw an isometric cube.

© Cengage Learning 2012

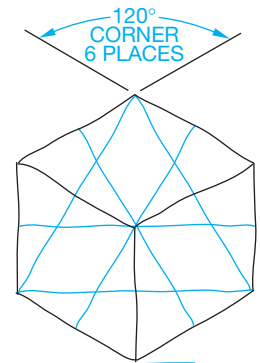
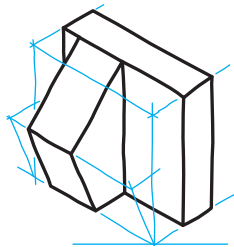


FIGURE 5.63 Step 2: Four-center isometric ellipse construction.

© Cengage Learning 2012



© Cengage Learning 2012

FIGURE 5.60 Step 4: Complete the sketch and darken all outlines.

**STEP 4** Sketch the nonisometric lines as shown in Figure 5.60 by connecting the points established in Step 3. Also darken all outlines.

## Sketching Isometric Circles

Circles and arcs appear as ellipses in isometric views. To sketch isometric circles and arcs correctly, you need to know the relationship between circles and the faces, or planes, of an isometric cube. Depending on which face the circle is to appear, isometric circles look like one of the ellipses shown in Figure 5.61. The angle the ellipse (isometric circle) slants is determined by the surface on which the circle is to be sketched.

To practice sketching isometric circles, you need isometric surfaces to put them on. The surfaces can be found by first sketching a cube in isometric. A cube is a box with six equal sides. Notice, as shown in Figure 5.62, that only three of the sides can be seen in an isometric drawing.

## Using the Four-Center Method

The four-center method of sketching an isometric ellipse is easier to perform, but care must be taken to form the ellipse arcs properly so the ellipse does not look distorted.

- STEP 1** Draw an isometric cube similar to Figure 5.62.
- STEP 2** On each surface of the cube, draw line segments that connect the  $120^\circ$  corners to the centers of the opposite sides (see Figure 5.63).
- STEP 3** With points 1 and 2 as the centers, sketch arcs that begin and end at the centers of the opposite sides on each isometric surface (see Figure 5.64).
- STEP 4** On each isometric surface, with points 3 and 4 as the centers, complete the isometric ellipses by sketching arcs that meet the arcs sketched in Step 3 (see Figure 5.65).

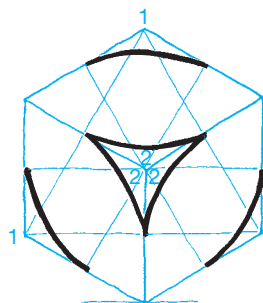


FIGURE 5.64 Step 3: Sketch arcs from points 1 and 2 as centers.

© Cengage Learning 2012

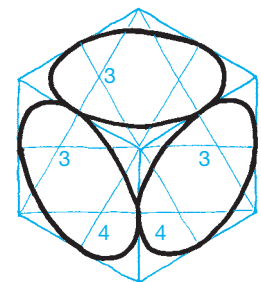


FIGURE 5.65 Step 4: Sketch arcs from points 3 and 4 as centers.

© Cengage Learning 2012

## Sketching Isometric Arcs

Sketching isometric arcs is similar to sketching isometric circles. First, block out the overall configuration of the object, then establish the centers of the arcs. Finally, sketch the arc shapes as shown in Figure 5.66. Remember that isometric arcs, just like isometric circles, must lie in the proper plane and have the correct shape.

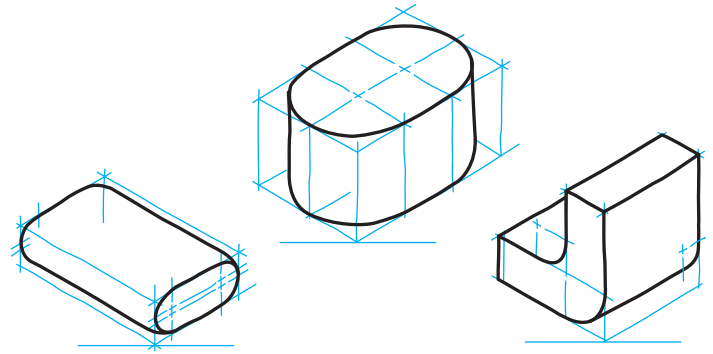
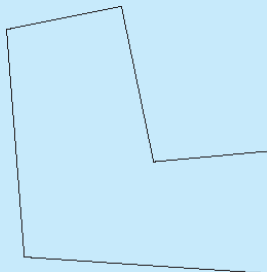


FIGURE 5.66 Sketching isometric arcs. © Cengage Learning 2012

## CADD SKETCHING

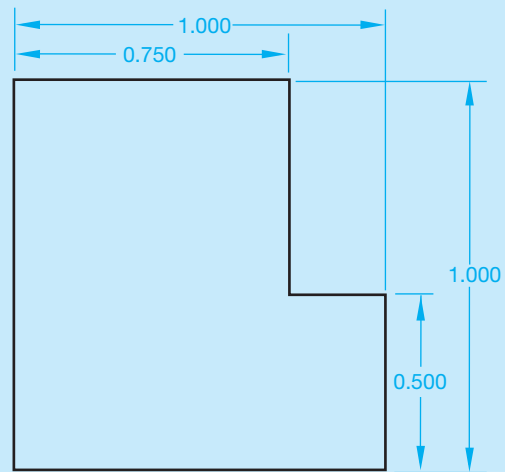
Sketches are very important engineering drafting and design tools. The very first drawings were sketches, and even after hundreds of years, sketches continue to be widely used to effectively communicate ideas and information in a variety of ways. In fact, sketches are an essential piece of modern 3-D modeling software programs. Sketching is done using a computer, and it is required when producing CADD models. Part sketches typically represent the first step in the creation of a model and provide the initial geometry, pattern, and profile used to develop models.

Just as with sketches drawn by hand, model sketches generally are easy to create and should not require very much time to complete. Initial sketch geometry is usually approximate and contains very few dimensions or other geometric relationships. The typical approach is to draw a basic shape or part outline quickly and easily and then add dimensions and geometric information. Often only two steps are required to develop a basic feature sketch. The first step involves drawing simple shapes using sketch tools such as LINE, CIRCLE, and ARC (see Figure 5.67). The second step requires defining the size and shape of the sketch using dimensions and geometric relationships as shown in Figure 5.68. The sketch is then used to build a model (see Figure 5.69).



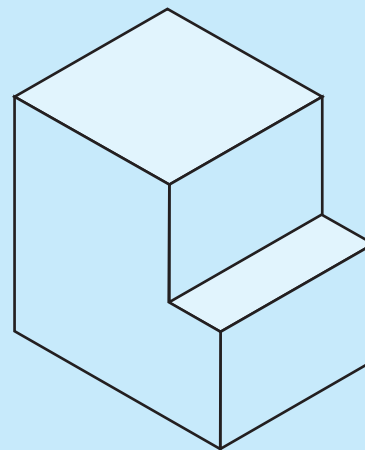
© Cengage Learning 2012

FIGURE 5.67 A basic sketch created using sketching tools.



Courtesy 3D Systems Corporation

FIGURE 5.68 Defining a sketch.



Courtesy 3D Systems Corporation

FIGURE 5.69 A simple model created by extruding a sketch.

(Continued)

Keep the following information in mind when developing model sketches:

- Fully close a sketch loop when developing a profile. If a gap or opened loop exists, you are not able to create some sketch features.
- Develop simple, often incomplete sketch geometry, and create as many objects as possible using feature tools. For example, place a round on an existing feature using feature tools, instead of drawing and dimensioning an arc in the sketch environment, using sketch tools.
- Fully define your sketch if applicable, but do not allow the sketch to become overdefined.

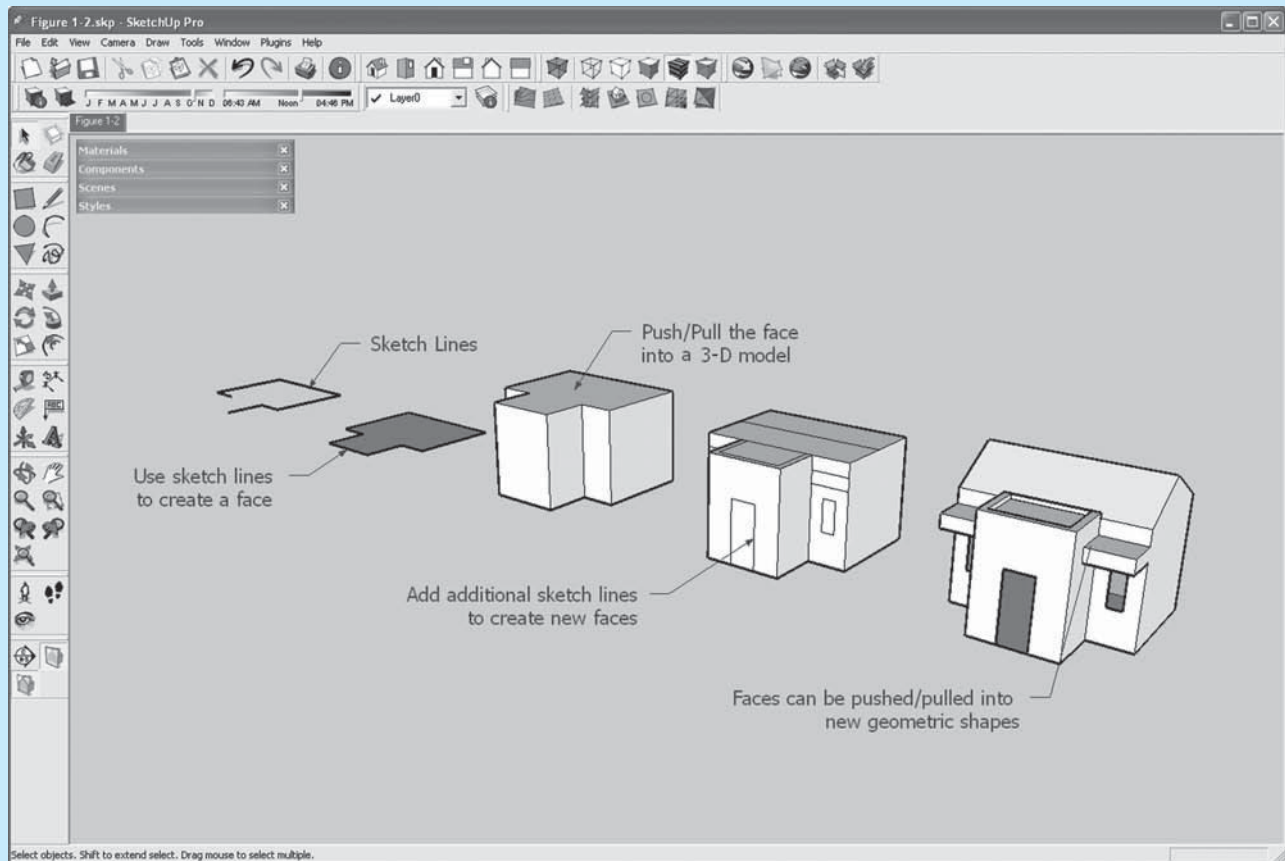
## USING CADD FOR CONCEPTUAL DESIGN AND PRESENTATION SKETCHES

Google SketchUp is a CADD program that can be used to create, share, and present 3-D models with an easy-to-use

interface. **Interface**, also called *user interface*, is the term describing the tools and techniques used to provide and receive information to and from a computer application. Google SketchUp is often used in the conceptual design phase of a project and to create presentation drawings that look hand sketched, as shown in Figure 5.70.

Tools such as Line, Arc, Rectangle, and Circle are used to sketch 2-D closed boundaries known as *faces*. Then tools such as the Push/Pull, Follow-Me, and Move are used to “pull” faces and edges into 3-D objects (see Figure 5.71). CADD graphic and image files can be imported into Google SketchUp and then traced over with sketch tools to create quick 3-D models for design studies (see Figure 5.72).

In addition to sketching and modeling tools, Google SketchUp can be used to add finish materials, hand-sketched styles, and shadows to create presentation drawings as shown in Figure 5.73. Custom appearances and feelings can be used to create a sampling of different presentation styles.

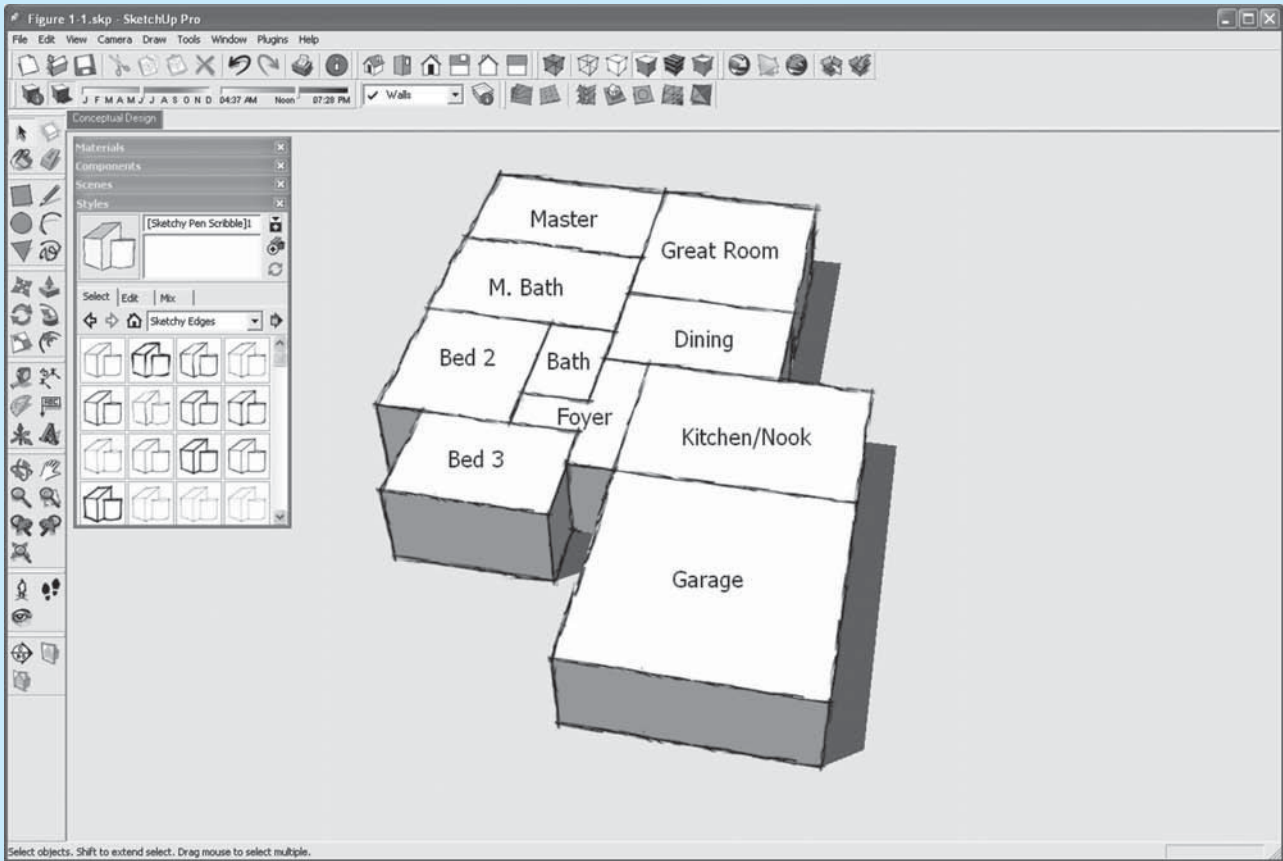


Courtesy Ron Palma. 3D-DZYN

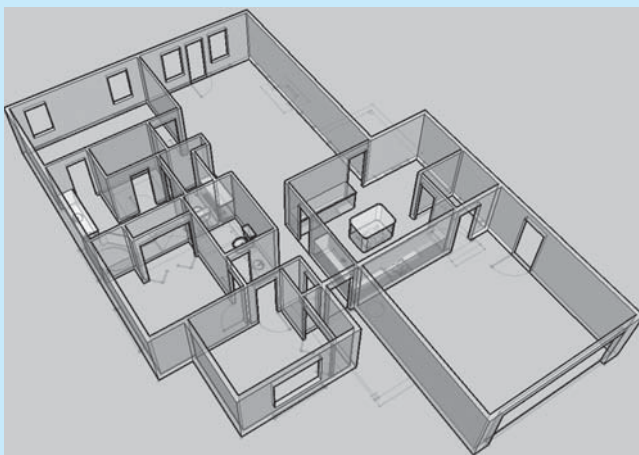
**FIGURE 5.70** Google SketchUp can be used in the conceptual architectural design phase to sketch new ideas and designs.

(Continued)

Courtesy/Ron Palma, 3D-DZYN



**FIGURE 5.71** In Google SketchUp, use sketch lines to create faces, then push and pull the faces into 3-D geometry.

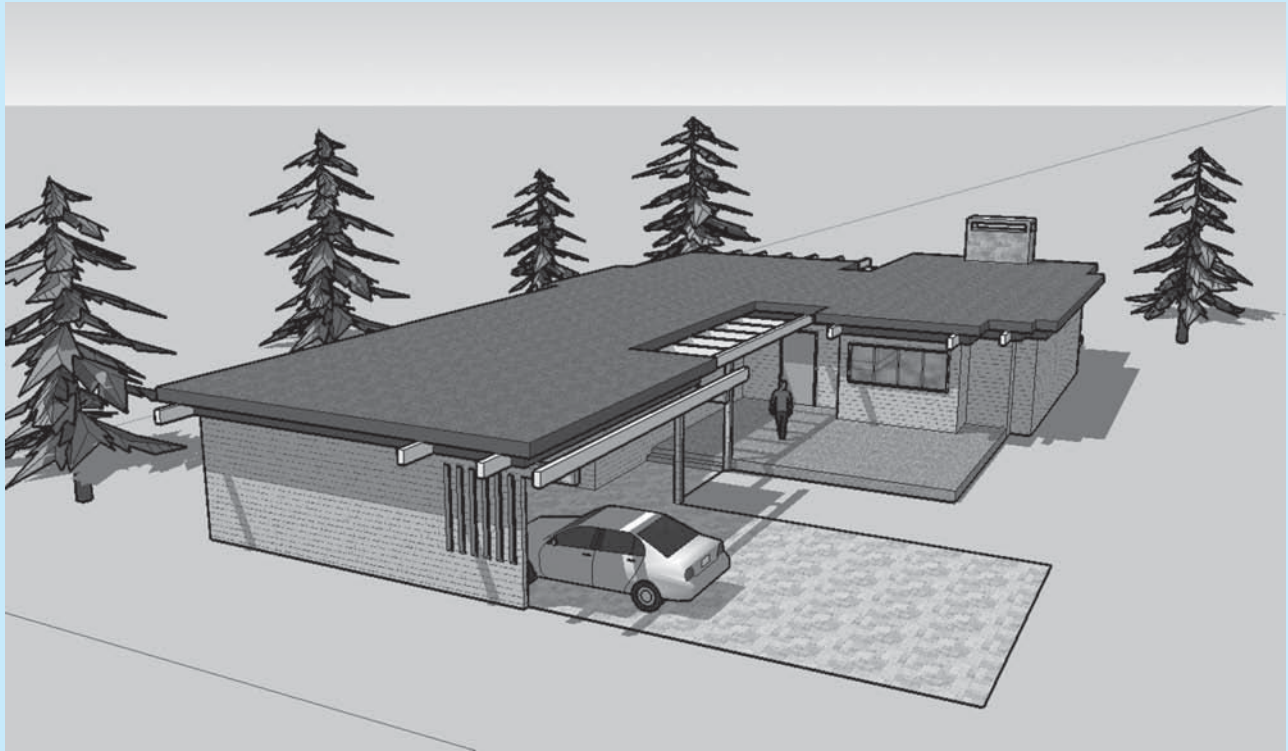


**FIGURE 5.72** Google SketchUp lines are traced over an imported image to create a 3-D model. *Courtesy Ron Palma, 3D-DZYN*

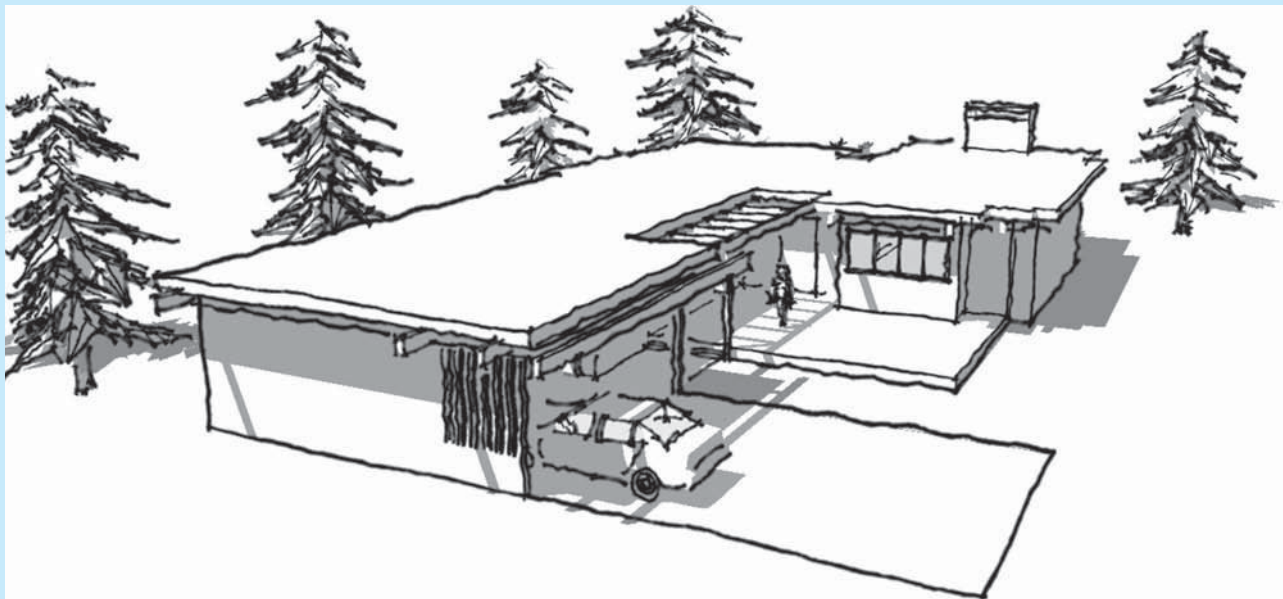
When used with Google Earth, a location from Google Earth can be found and imported into Google SketchUp. A new design idea is sketched relative to the Google Earth location. The Google SketchUp file is then imported back into Google Earth to create a 3-D presentation file of the design within Google Earth as shown in Figure 5.74.

Google SketchUp is available for download from the Google Web site and comes in two formats. Google SketchUp is a free download and allows you to create 3-D models very quickly. Google SketchUp Pro is a premium version and includes all of the tools from the free version plus advanced settings for commercial use and interaction with other CADD programs.

(Continued)



(a)

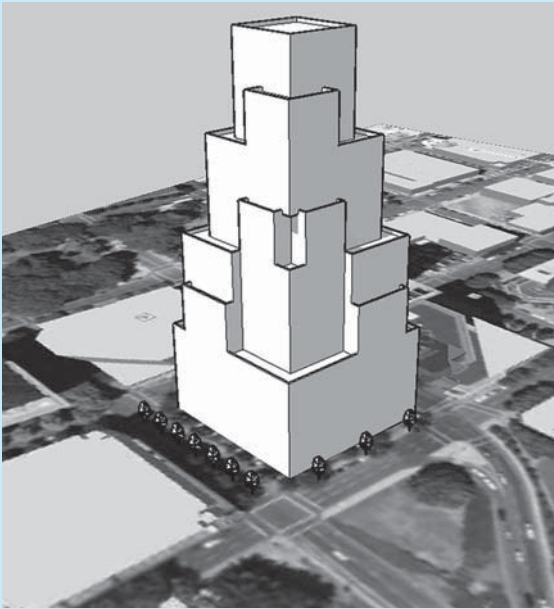


(b)

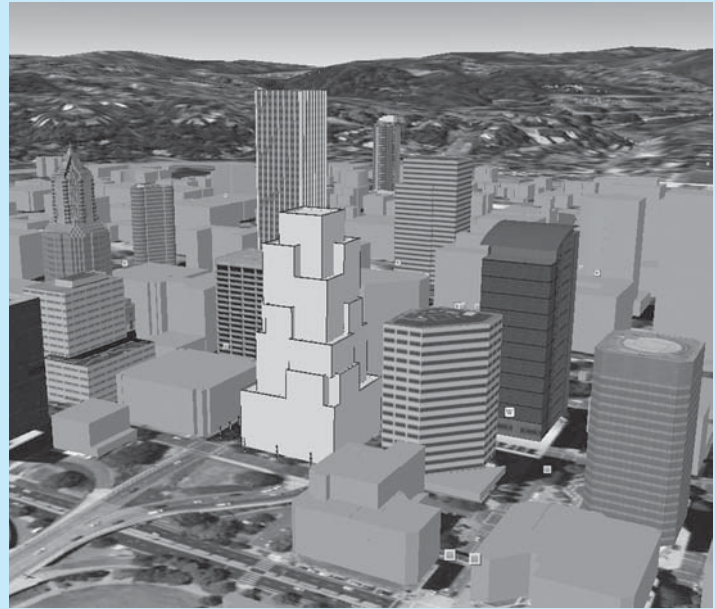
**FIGURE 5.73** (a) Apply different materials and sketch styles to 3-D model geometry to create unique presentation drawings. (b) Continued.

Courtesy Ron Palma, 3D-DZYN

(Continued)



(a)



(b)

Courtesy Ron Palma, 3D-DZVN

**FIGURE 5.74** (a) Use Google Earth to import a site into Google SketchUp. (b) Design the 3-D model, and then send the model back into Google SketchUp for design review.

## PROFESSIONAL PERSPECTIVE

### SKETCHING

Freehand sketching is an important skill as a drafter. Preparing a sketch before you begin a formal drawing can save many hours of work. The sketch assists you in the layout process because it allows you to:

- Decide how the drawing should appear when finished.
- Determine the size of the drawing.

- Determine the sheet layout.
- Establish coordinate points if needed.

A little time spent sketching and planning your work saves a lot of time in the final drafting process. Sketches are also a quick form of communication in any professional environment. You can often get your point across or communicate more effectively with a sketch.

## Chapter 5

### Chapter 5 Sketching Applications Test



To access the Chapter 5 test, go to the Student CD, select **Chapter Tests and Problems**, and then **Chapter 5**. Answer the questions

with short, complete statements, sketches, or drawings as needed. Confirm the preferred submittal process with your instructor.

# Chapter 5 Sketching Applications Problems

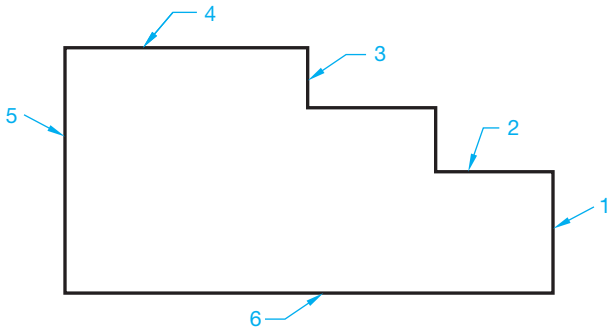
## INSTRUCTIONS

Use proper sketching materials and techniques to solve the following sketching problems on  $8\frac{1}{2} \times 11$  in. bond paper or newsprint, unless otherwise specified by your instructor. Use very lightly sketched construction lines for all layout work. Darken the finished lines, but do not erase the layout lines, unless otherwise specified by your instructor.

### Part 1: Problems 5.1 Through 5.6

#### PROBLEM 5.1

List on a separate sheet of paper the length, direction, and position of each line shown in the drawing. Remember, do not measure the lines with a scale. Example: Line 2 is the same length as line 1 and touches the top of line 1 at a  $90^\circ$  angle.



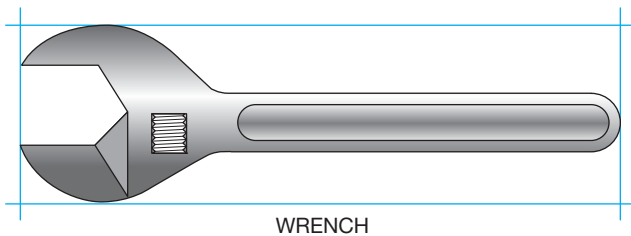
© Cengage Learning 2012

#### PROBLEM 5.2

Use the box, centerline, hand-compass, and trammel methods to sketch a circle with an approximately 4 in. diameter.

#### PROBLEM 5.3

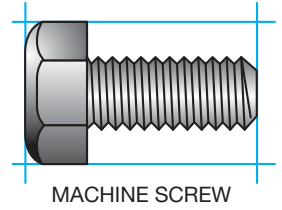
Make a sketch of the wrench in the following figure. Use a frame of reference to make your sketch twice as big as the given sketch.



© Cengage Learning 2012

#### PROBLEM 5.4

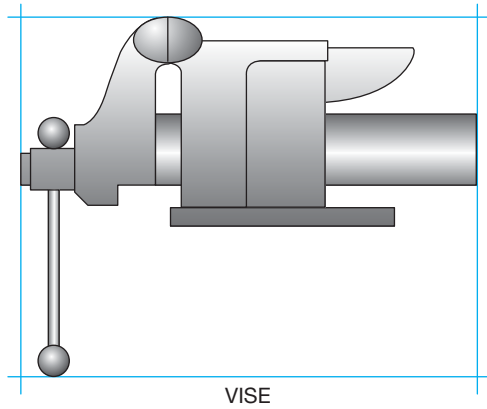
Make a sketch of the machine screw in the figure shown right. Use a frame of reference to make your sketch twice as big as the given sketch.



© Cengage Learning 2012

#### PROBLEM 5.5

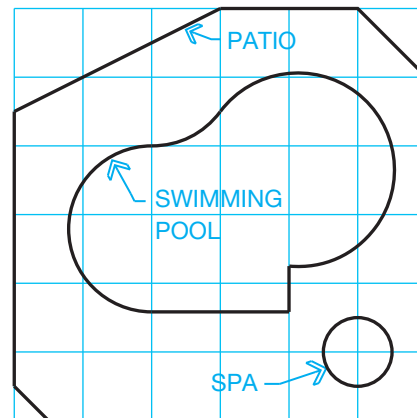
Make a sketch of the vise in the following figure. Use a frame of reference to make your sketch twice as big as the given sketch.



© Cengage Learning 2012

#### PROBLEM 5.6

Make a sketch of the patio, swimming pool, and spa in the following figure. Use a frame of reference to make your sketch twice as big as the given sketch.

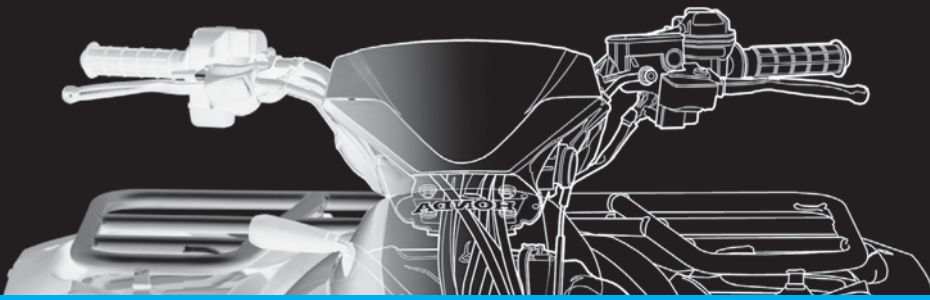


© Cengage Learning 2012

### Part 2: Problems 5.7 Through 5.12



To access the Chapter 5 problems, go to the Student CD, select **Chapter Tests and Problems** and **Chapter 5**, and then open the problem of your choice or as assigned by your instructor. Solve the problems using the instructions provided on the CD, unless otherwise specified by your instructor.



# CHAPTER 6

## Lines and Lettering

### LEARNING OBJECTIVES

After completing this chapter, you will:

- Identify the lines found on a given industry drawing.
- Draw ASME standard lines.
- Solve given engineering problems.
- Create ASME standard text.
- Answer questions related to lines and lettering.

## THE ENGINEERING DESIGN APPLICATION

The Engineering Design Application provided in Chapter 5 discussed sketches used during the design process and the importance of converting engineering sketches to formal drawings that properly convey national drafting standards. The wide variety of drafting and design disciplines are covered throughout this textbook. These disciplines include the major categories of manufacturing, structural, civil, sheet metal, industrial pipe, and electrical and electronic drafting applications. There is a vast amount of information for you to learn, and each discipline has its own techniques and practices. Your challenge, as a professional drafter, is to convert engineering sketches and other given information into formal, standard drawings that effectively communicate the design intent. If you take your profession seriously, your desire will be to create drawings that provide complete and accurate information and represent the best possible quality.

The content in this textbook guides you to this objective. This textbook provides drafting standards, practices, and applications. Your responsibility is to convert what you learn into formal drawings that meet different challenges. The example engineering sketch and resulting drawing

shown in Figure 5.1 represents the basic idea, but you will learn what is needed to solve problems and produce drawings that are much more complex. Your discovery in this chapter includes lines and letters used in a specific manner for you to communicate an engineering design concept to the people who manufacture or construct the product or structure. The drawings you create can be considered a technical work of art. The lines and letters are combined in a manner that clearly and skillfully demonstrates your communication. Actual industry drawing examples are given throughout this book to help reinforce and pull together what you have learned in each chapter. Although these drawings represent only one possible solution to the specific problem, they are intended to show what you can accomplish and to demonstrate the quality you should aspire to achieve.

Look at the drawing found in Figure 6.45. This drawing is complex, but it shows what you will be able to accomplish. Carefully study and practice the content covered in this textbook. Take every opportunity to look at real-world industry drawings provided and available at companies near your home or school.

### LINES

**Drafting** is a graphic language using lines, symbols, and notes to describe objects to be manufactured or built. Lines on drawings must be of a quality that reproduces easily. All lines are dark, crisp, sharp, and of the correct thickness when properly drawn. There is no variation in line darkness, only a variation in line thickness, known as **line contrast**. Certain lines are drawn thick so they stand out clearly from other information on the

drawing. Other lines are drawn thin. Thin lines are not necessarily less important than thick lines, but they are subordinate for identification purposes.

### STANDARDS

**ASME** The American Society of Mechanical Engineers (ASME) recommends two line thicknesses: thick and thin lines. Standard line thicknesses are 0.6 mm minimum for



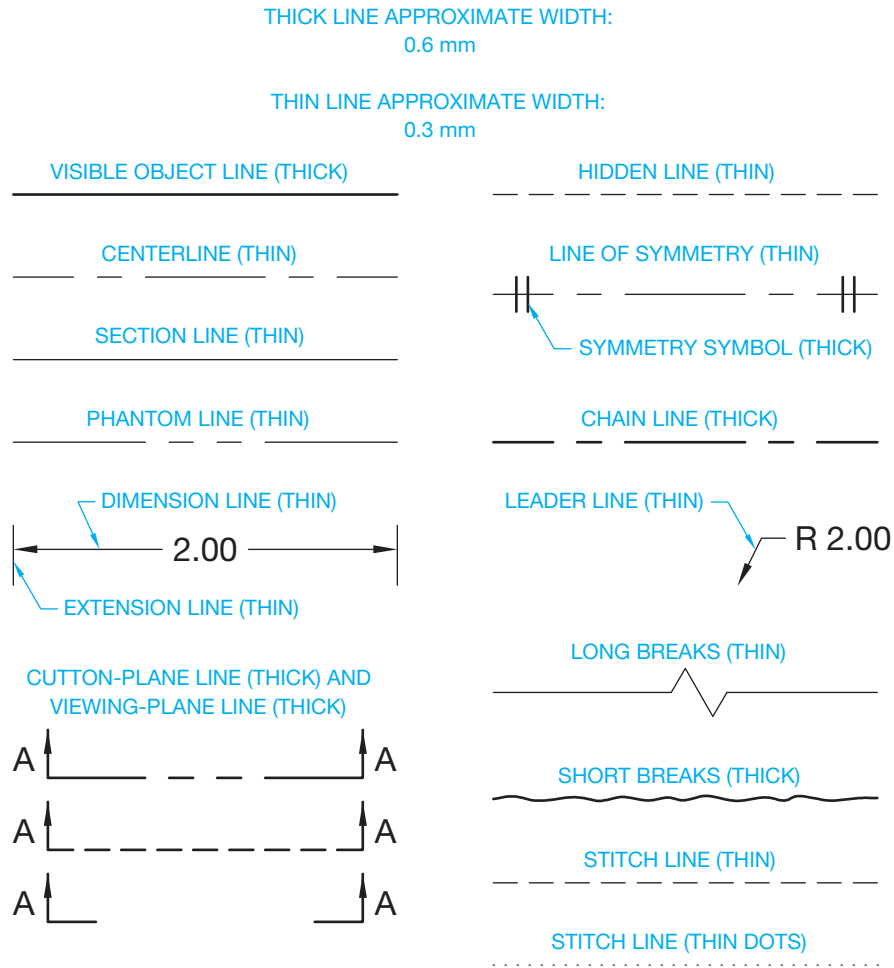


FIGURE 6.1 Line conventions, type of lines, and recommended line widths.

thick lines and 0.3 mm minimum for thin lines. The approximate inch conversion is .02 in. (0.6 mm) for thick lines and .01 in. (0.3 mm) for thin lines. This establishes a two-to-one ratio between thick and thin lines. The actual width of lines can vary from the recommended thickness, depending on the size of the drawing or the size of the final reproduction. All lines of the same type should have uniform thickness throughout the drawing. Figure 6.1 shows widths and types of lines as taken from ASME standard *Line Conventions and Lettering*, ASME Y14.2. Figure 6.2 shows a sample drawing using the various kinds of lines. When parallel lines are very close together, their separation can be exaggerated by a maximum of 3 mm so the space between the lines does not fill in when the drawing is reproduced.

**MIL-STD** or military (MIL) standards recommend three line thicknesses: thick (cutting and viewing plane, short break, and object), medium (hidden and phantom), and thin (center, dimension, extension, leader, long break, and section). The content and examples used in this chapter are based on the ASME standard.



**NOTE:** Drawings in figures throughout this textbook have been reduced to fit in small places for representative purposes and to save space. Drawings that are reduced to this extent do not display the proper ASME line thicknesses and styles. Look for actual drawings in your classroom or at a local industry so you can see the proper ASME line thicknesses being used. When working on drawing problems throughout this textbook, pay attention to making correct ASME line thicknesses and styles.

## TYPES OF LINES

The following discussion is an introduction to the lines that are commonly used on engineering drawings. You will use only a few of these lines as you work on the problems for this chapter. You will use additional lines as you continue to learn about specific applications throughout this text. For example, Chapter 10, *Dimensioning and Tolerancing*, covers the lines used in dimensioning in detail, and Chapter 12, *Sections, Revolutions, and Conventional Breaks*, covers sectioning practices. You will put the use of lines to practice in every chapter where specific engineering drafting applications are fully explained.

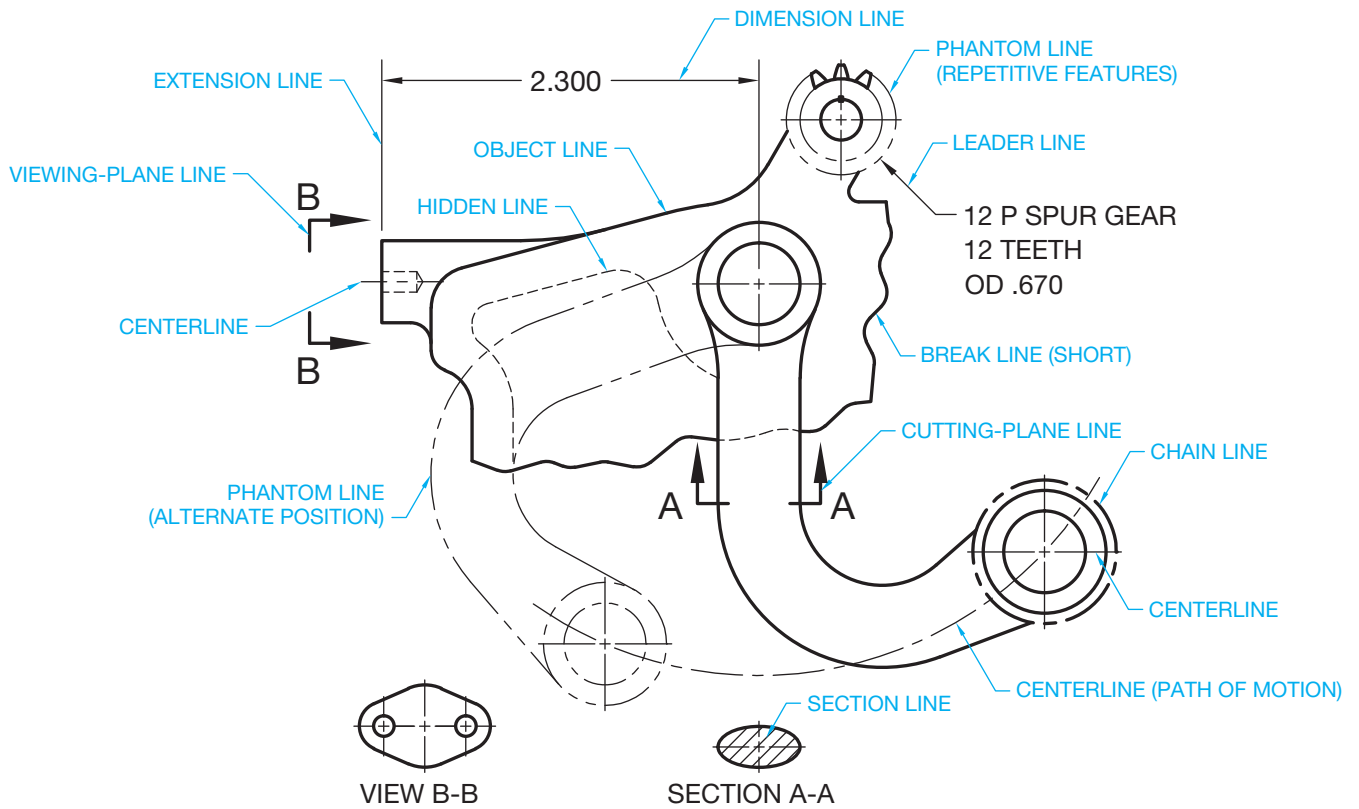


FIGURE 6.2 Sample drawing with a variety of lines used and identified.

© Cengage Learning 2012

## Construction Lines

**Construction lines** are used for laying out a drawing. Construction lines are not one of the ASME standard line types because they do not represent a specific drawing feature and are not reproduced on the final drawing. Use construction lines for all preliminary work. Construction lines are usually drawn using a unique format called **layers** on your CADD drawing. This layer can be named something such as CONSTRUCTION and assigned a specific color. If necessary, review the layers discussion in Chapter 3. Construction lines created using a separate format can be removed easily or set so they do not display or plot when the layout work is finished.

## Visible Lines

**Visible lines**, also called *object lines* or *outlines*, describe the visible surface or edge of the object. Visible lines are drawn as thick lines as shown in Figure 6.3. Thick lines are drawn .02 in. (0.6 mm) wide.

Visible lines are usually drawn on a layer named something such as OBJECT and assigned a specific color, the visible line style, and the recommended thickness of .02 in. (0.6 mm). Depending on the CADD system used, the line thickness can be displayed on the screen while drawing or represented in the final print or plot of the drawing. Some CADD programs refer to line thickness as *line weight*.

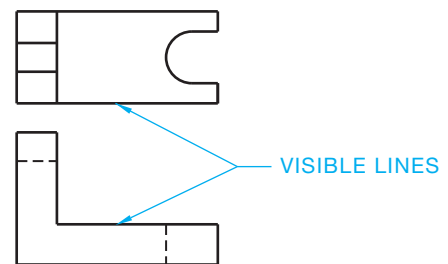


FIGURE 6.3 Visible lines.

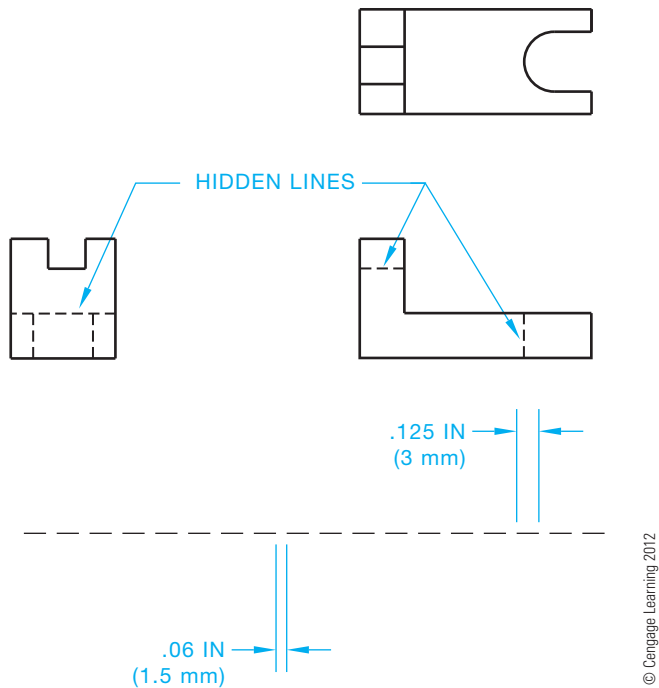
© Cengage Learning 2012

## Hidden Lines

A **hidden line** represents an invisible edge on an object. Hidden lines are thin lines drawn .01 in. (0.3 mm) thick. Hidden lines are half as thick as object lines for contrast. Figure 6.4 shows hidden lines drawn with .125 in. (3 mm) dashes spaced .06 in. (1.5 mm) apart. This example represents the uniformity and proportions desired in hidden lines. However, the length and spacing of dashes can vary slightly in relation to the drawing scale. All hidden lines on a drawing should have the same dash length and spacing for uniformity.

## Hidden Line Rules

The drawings in Figure 6.5 show situations where hidden lines meet or cross object lines and other hidden lines. These



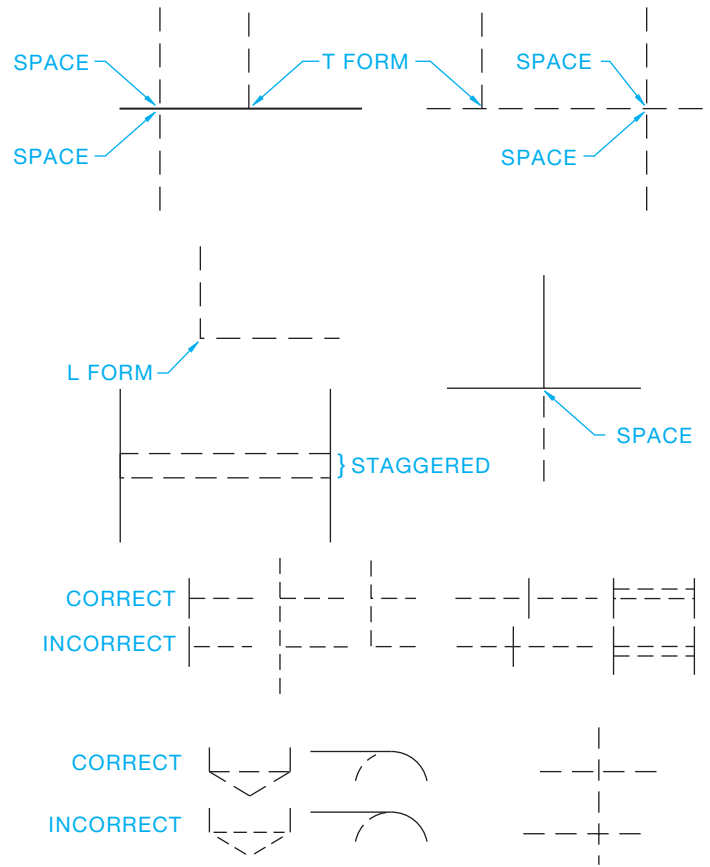
**FIGURE 6.4** Hidden line representation. The length and spacing of dashes can vary slightly in relation to the drawing scale. All hidden lines on a drawing should have the same dash length and spacing for uniformity.

situations represent rules that should be followed when possible. Some CADD programs have limitations that do not allow you to conform to these recommendations.

The dash length and spacing can be adjusted to match the desired standard when using most CADD programs. Some initial experimentation may be needed to get the correct line representation, depending on the size of your drawing and other scale factors within the CADD program. You may also have some difficulty applying all of the hidden line rules, but most CADD systems should give you the desired T and L form characteristics shown in Figure 6.5. Hidden lines are usually drawn on a layer named something such as HIDDEN. A hidden line format contains information such as the hidden line style, a contrasting color that helps distinguish hidden lines from other lines, and the recommended thickness of .01 in. (0.3 mm).

## Centerlines

**Centerlines** are used to show and locate the centers of circles and arcs and to represent the center axis of a circular or symmetrical form. Centerlines are also used to show the centers in a bolt circle pattern or the paths of motion in a mechanism. Centerlines are thin lines on a drawing with the recommended thickness of .01 in. (0.3 mm). Centerlines are half as thick as object lines for contrast. Centerlines are drawn using a series of alternating long and short dashes. Generally, the long dash is about .75 to 1.50 in. (19–35 mm). The spaces between dashes are about .062 in. (1.5 mm) and the short dash about .125 in. (3 mm) long. The length of long line segments can vary for the situation and size of the drawing. Try to keep the long lengths

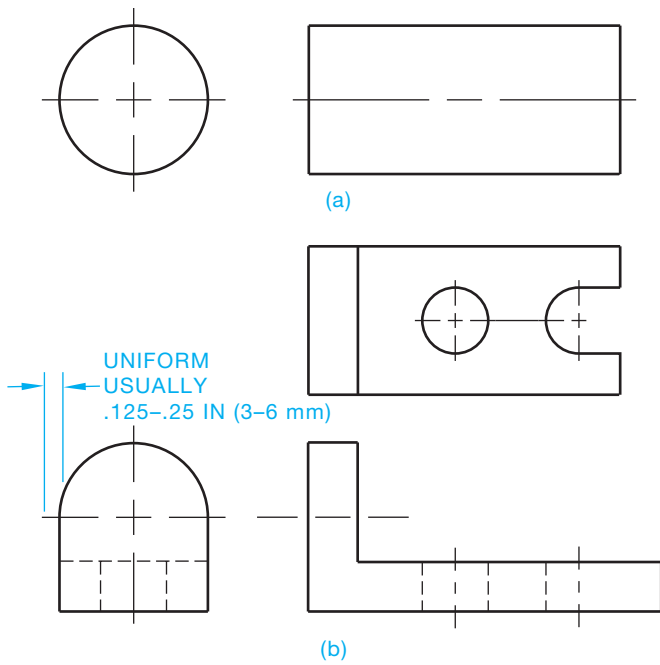


**SOME OF THESE PRACTICES CAN BE DIFFICULT TO DO WITH CADD.**

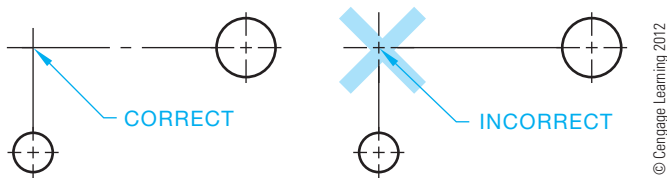
**FIGURE 6.5** Recommended hidden line rules. © Cengage Learning 2012

uniform throughout each centerline and throughout the drawing (see Figure 6.6). Centerlines should start and end with long dashes. Centerlines should extend uniformly a short distance, such as .125 in. (3 mm) or .25 in. (6 mm), past an object. The distance the centerline goes past the object depends on the size of the drawing and company standards. The uniform distance past an object is maintained unless a longer distance is needed for dimensioning purposes (see Figure 6.6). When a centerline is used to establish a dimension, the centerline continues as an extension line without a gap where the centerline ends and the extension line begins. This is discussed more in Chapter 10. Small centerline dashes should cross only at the center of a circle or arc (see Figure 6.7). Small circles should have centerlines as shown in Figure 6.8. Centerlines do not extend between views of the drawing, except as discussed with auxiliary views in Chapter 9. Very short centerlines can be continuous without the standard long dash–short dash configuration, but this should be avoided if possible and there will be no confusion with other lines.

Centerlines for features in a **bolt circle** can be drawn either of two ways, depending on how the features are located when dimensioning, as shown in Figure 6.9. A bolt circle is a pattern of holes or other features arranged in a circle. The drawing in Figure 6.9a represents the centerline method used when applying polar coordinate dimensioning, and the drawing



**FIGURE 6.6** Centerline representation and examples. (a) Centerlines placed in two views of a cylindrical object. (b) Centerlines shown in the views related to circle and arc features. © Cengage Learning 2012



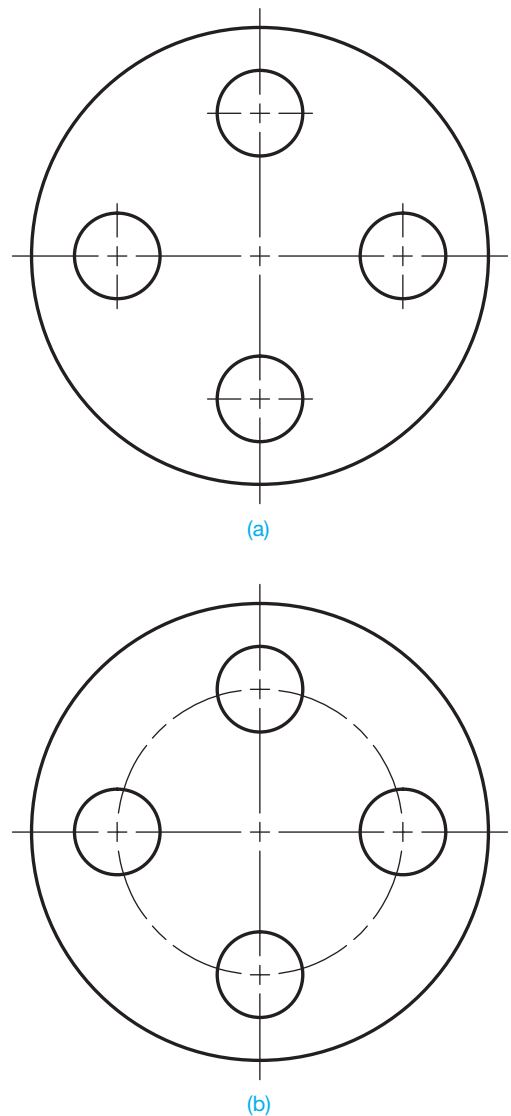
**FIGURE 6.7** Centerline rules. These drawings have been reduced to fit in the space available. Keep in mind that the center dashes should be .125 in. (3 mm) long. © Cengage Learning 2012



**FIGURE 6.8** Centerlines for small circles. These drawings have been reduced to fit in the space available. Keep in mind that the center dashes should be .125 in. (3 mm) long. © Cengage Learning 2012

in Figure 6.9b is an application of centerlines used for rectangular coordinate dimensioning. **Polar coordinate dimensions** use a combination of angular and linear dimensions to locate features from planes, centerlines, or center planes. **Rectangular coordinate dimensioning** is a system of using linear dimensions to locate features from planes, centerlines, and center planes. Dimensioning practices are described in detail in Chapter 10.

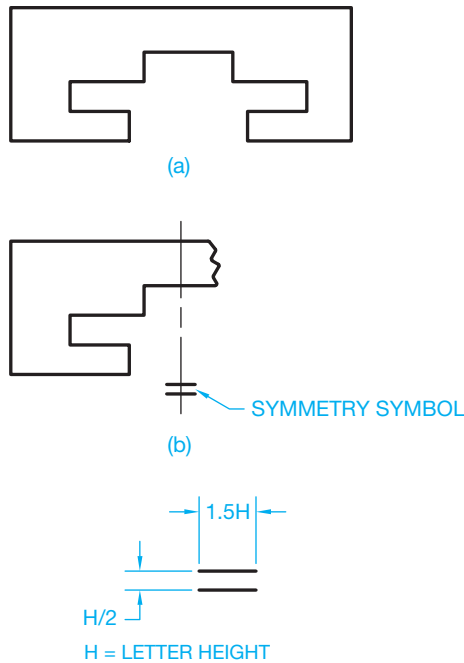
A centerline should only be drawn on round parts. A centerline should not be drawn to show a center plane. However, a centerline can represent the center plane of a symmetrical part when necessary as shown in Figure 6.10a. A symmetry symbol can be placed only on a partial view of parts that are too big for the drawing sheet. In this case, only a little more than half of the view is drawn as shown in Figure 6.10b. The symmetry symbol



**FIGURE 6.9** Bolt circle centerline options. (a) Centerline format for polar coordinate dimensioning. (b) Centerline format for rectangular coordinate dimensioning. Dimensioning practices are described in Chapter 10. © Cengage Learning 2012

should not be used if the entire part is drawn. The symmetry symbol is two short thick parallel lines placed near the centerline ends outside the view and drawn at 90° to the centerline.

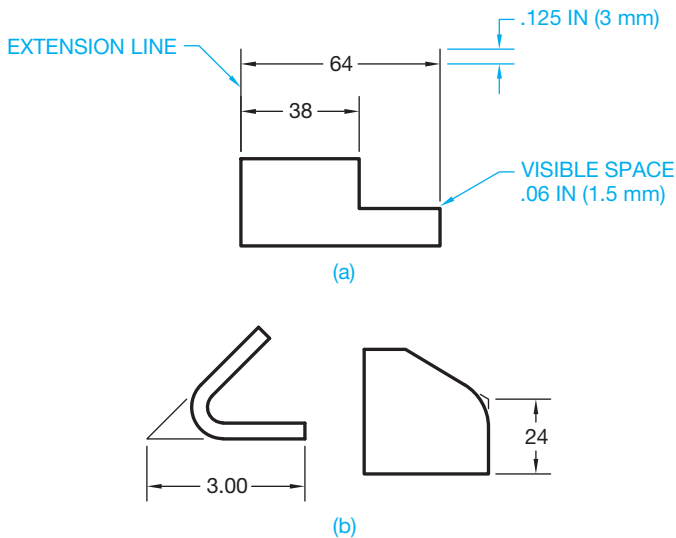
Centerlines should also be represented as previously discussed when using CADD. The dash length and spacing can be adjusted to match the desired standard when using most CADD programs. Some initial experimentation may be needed to get the correct line representation, depending on the size of your drawing and other scale factors within the CADD program. You may also have some difficulty applying all of the centerline rules, but most CADD systems should give you the desired results with some variation. Centerlines are usually drawn on a layer named something such as CENTER. A centerline format contains information such as the centerline style, a contrasting color that helps distinguish centerlines from other lines, and the recommended thickness of .01 in. (0.3 mm).



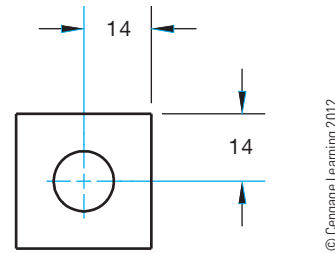
**FIGURE 6.10** Using a symmetry symbol to identify the line of symmetry when a partial view is drawn representing a symmetrical object. The symmetry symbol should only be used on a partial view. (a) A view showing symmetrical features. (b) A partial view using the symmetrical symbol.

### Extension Lines

**Extension lines** are thin lines used to establish the extent of a dimension as shown in Figure 6.11a. Extension lines can also be used to show the extension of a surface to a theoretical intersection as shown in Figure 6.11b. Extension lines begin with a .06 in. (1.5 mm) space from the object and extend to about .125 in. (3 mm) beyond the last dimension, as shown in Figure 6.11. Extension lines can cross object lines, centerlines,



**FIGURE 6.11** Extension line examples. (a) Typical extension use with dimensions. (b) Extension lines used at apparent intersections of extended features.

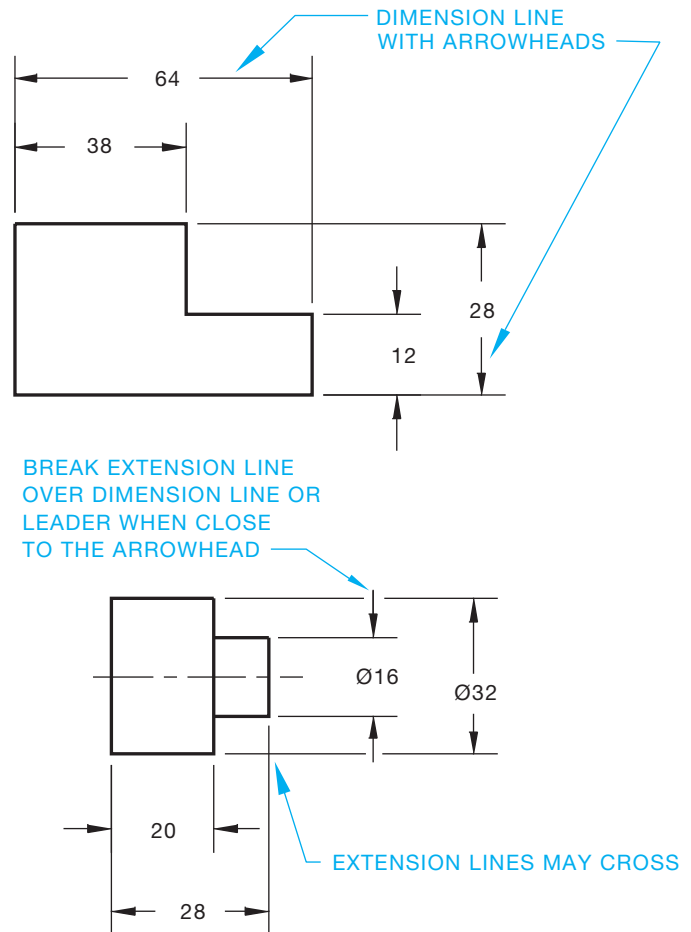


**FIGURE 6.12** The centerline becomes an extension line where it extends to a dimension when used for dimensioning.

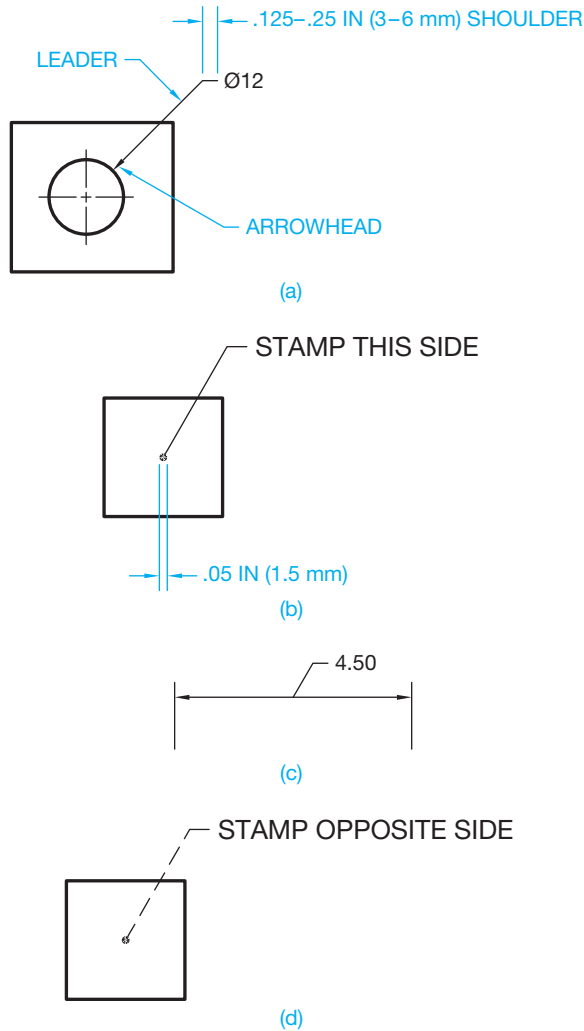
hidden lines, and other extension lines, but they should not cross dimension lines. Circular features, such as holes, are located to their centers in the view where they appear as circles. In this practice, centerlines become extension lines for dimensioning purposes as shown in Figure 6.12.

### Dimension Lines and Leader Lines

**Dimension lines** are thin lines capped on the ends with arrowheads and broken along their length to provide a space for the dimension numeral. Dimension lines indicate the length of the dimension (see Figure 6.13). There are several correct options for placing dimension lines as described in Chapter 10.



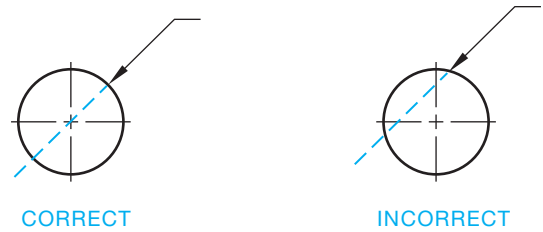
**FIGURE 6.13** Dimension line applications. © Cengage Learning 2012



© Cengage Learning 2012

**FIGURE 6.14** Leader lines and use. (a) Typical leader line application and characteristics. (b) A leader line is terminated with a dot when pointing inside the outline of an object. (c) A leader line is displayed without an arrowhead or dot when connected to a dimension line. This practice is used when there is not enough space in the dimension line to provide the dimension numeral. (d) Leader lines are drawn using a hidden line style when pointing to a hidden surface.

**Leader lines**, or **leaders**, are thin lines used to connect a specific note to a feature as shown in Figure 6.14a. Leader lines are also used to direct dimensions, symbols, item numbers, and part numbers on a drawing. Leaders can be drawn at any angle, but 45°, 30°, and 60° lines are most common. Slopes greater than 75° or less than 15° from horizontal should be avoided. The leader typically has a short shoulder at one end that begins at the center of the vertical height of text, and a standard dimension arrowhead is placed at the other end touching the feature. The ASME standard does not specify a length for the short shoulder, but .125–.25 in. (3–6 mm) is common. Make the shoulder length uniform throughout the drawing. Some leader applications can be drawn without a shoulder. A leader line is capped with a .05 in. (1.5 mm) dot when the leader points inside the object as shown in Figure 6.14b. The arrowhead is



**FIGURE 6.15** Circle to leader line relationship. When a leader arrowhead touches a circle or arc, the path of the leader should pass through the center of the circle or arc if it were to continue.

© Cengage Learning 2012

omitted when a leader line points to a dimension line. This is done when there is not enough space for text to be inserted at the dimension line, and the text is connected to the leader as shown in Figure 6.14c. A leader line is normally drawn using a thin continuous line style but can be a hidden line style when pointing to a hidden feature as shown in Figure 6.14d.

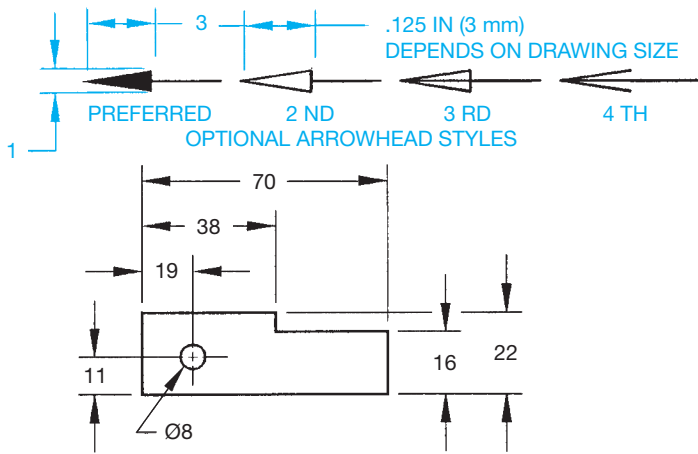
When dimensioning to a circle, such as a hole, the leader arrowhead touches the circle as shown in Figure 6.14a. If the leader were to continue from the point where the arrowhead touches the circle, it would intersect the center of the circle. Figure 6.15 shows the correct and incorrect application. The following are basic leader line rules in addition to the previous discussion:

- Leader lines should not cross each other.
- Leader lines should not be excessively long.
- Leader lines should not be parallel to dimension lines, extension lines, or section lines.
- Leader lines should not be vertical or horizontal.

## Arrowheads

**Arrowheads** are used to terminate dimension lines and leader lines and on cutting-plane lines and viewing-plane lines described later. Properly drawn arrowheads should be three times as long as they are wide. All arrowheads on dimension lines and leader lines should be the same size throughout the drawing. Do not use small arrowheads in small spaces. Applications of limited space dimensioning are covered in Chapter 10 (see Figure 6.16). Arrowheads should be proportional to the thickness of the line type on which they are placed. This means that arrowheads placed on cutting- and viewing-plane lines can be twice as big as arrowheads on dimension and leader lines because of the line thickness used. Individual company preference dictates whether arrowheads are filled in or left open as shown in Figure 6.16. The filled arrowhead style is common because it shows up best on the drawing.

CADD programs normally allow you to select from a variety of available arrowhead options. You should be able to match the desired ASME standard or the standard used by your company or drafting application. Most CADD systems allow you to control the display of every dimension element, including the size of arrowheads, and the location of arrowheads in relationship to the dimension text placement. The commonly preferred arrowhead



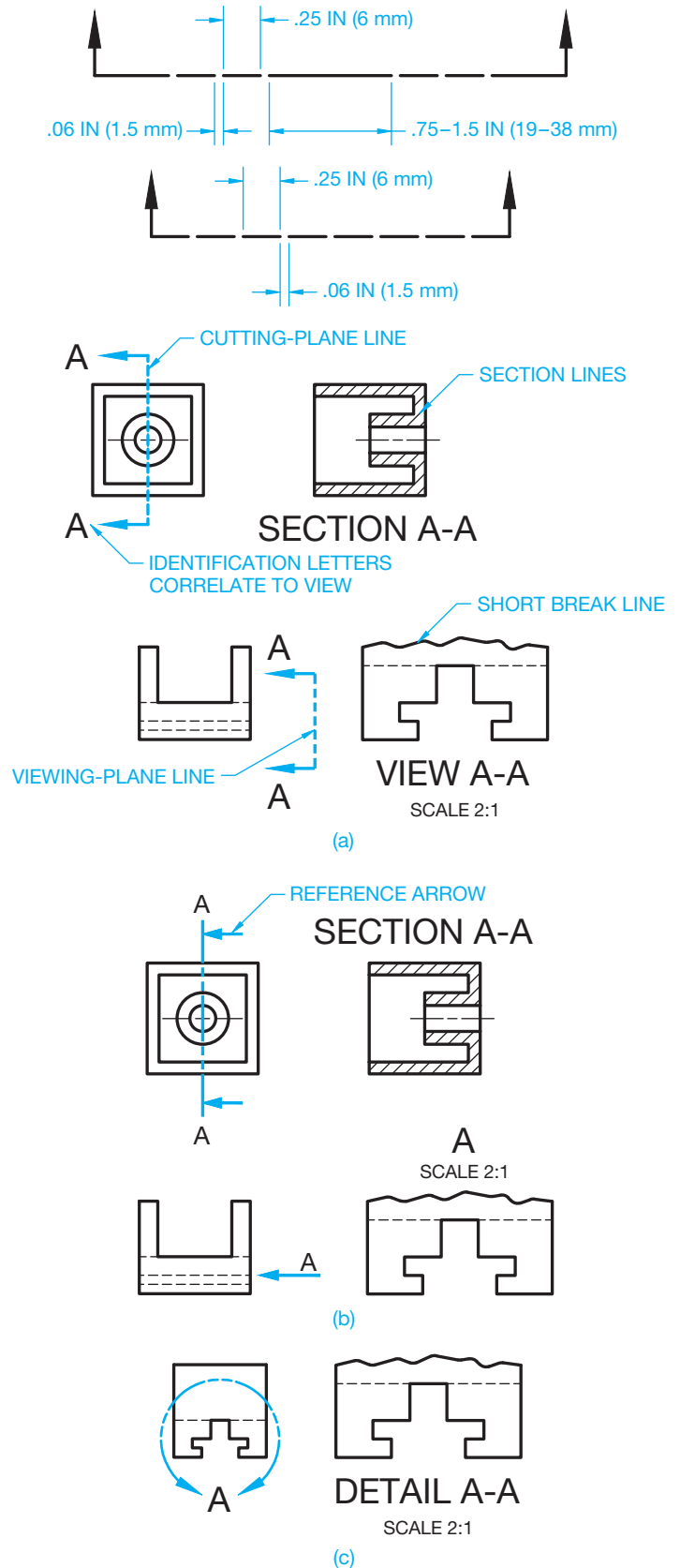
**FIGURE 6.16** Arrowhead options and use. The filled arrowhead is generally preferred because of its clarity.

for engineering drawings is filled (solid), but this standard can be different between offices. The solid, filled arrowhead stands out clearly on the drawing and helps identify the dimension location. Dimensions are usually drawn on layers that can be named DIM or DIMENSIONS, for example. A dimension format contains information such as the line style, text placement, arrowhead style and size, a contrasting color that helps distinguish dimensions from other lines, and text. The recommended dimension and leader line thickness is .01 in. (0.3 mm). Chapter 10 provides additional information and detailed standards for dimensioning practice and applications.

### Cutting-Plane and Viewing-Plane Lines

**Cutting-plane lines** are thick lines used to identify where a sectional view is taken. **Viewing-plane lines** are also thick and used to identify where a view is taken for view enlargements, removed views, or partial views. The cutting-plane line takes precedence over the centerline when used in the place of a centerline. Cutting-plane and viewing-plane lines are properly drawn in either of the two ways. One method uses alternately placed long and two short dashes, and the other uses equally spaced short dashes. Figure 6.17a shows the approximate dash and space sizes. The long dashes can vary in length, depending on the size and scale of the drawing. The ends of the cutting- and viewing-plane lines turn 90° and are capped with arrowheads. The arrowheads represent the direction of sight for viewing. The cutting- and viewing-plane lines can be labeled with letters such as A at each end of the line. These letters are correlated to the section or view title, such as SECTION A-A or VIEW A-A in Figure 6.17a. The scale of the view can be increased or remain the same as the view from the cutting- or viewing-plane, depending on the clarity of information presented. The scale of an enlarged view is placed under the view title as shown in Figure 6.17a. An alternate technique for placing the cutting- and viewing-plane lines is called the **reference arrow method**. When using the reference arrow method for identifying sections,

© Cengage Learning 2012



**FIGURE 6.17** (a) Cutting- and viewing-plane line styles and use. (b) Using the reference arrow method for displaying cutting- and viewing-plane lines. (c) Using a viewing plane to establish a detail view. © Cengage Learning 2012

arrowheads point toward each end of the cutting-plane line, and the section identification letters are placed at the ends of the cutting-plane lines. The reference arrow method is used for removed views where a single arrow and reference letter are used to identify removed views. The view title is placed above the removed section or view when using the removed arrow method (see Figure 6.17b). A **detail view** can be used in situations where it is necessary to show more detail than is displayed in the existing view. When the detail view is used, the viewing line is a partial circle placed around the view to be enlarged. The circle has an opening where a view identification letter is placed. The circle line is thick and drawn with a long dash and two short dash style and is capped with arrowheads next to the letter. The detail view can be placed anywhere on the drawing and is labeled with a title such as DETAIL A and a scale as shown in Figure 6.17c. Chapter 8, *Multiviews*; Chapter 9, *Auxiliary Views*; and Chapter 12, *Sections, Revolutions, and Conventional Breaks*, provide additional information about viewing and sectioning techniques.

When the location of the cutting plane or viewing plane is easily understood or if the clarity of the drawing is improved, the portion of the line between the arrowheads can be omitted as shown in Figure 6.18.

### Section Lines

**Section lines** are thin lines used in the view of a section to show where the cutting-plane line has cut through material (see Figure 6.19). Section lines are optional but generally used to show the material being cut by the cutting plane. Section lines are drawn equally spaced at 45°, but they cannot be parallel or perpendicular to any line of the object. Any convenient angle can be used to avoid placing section lines parallel or perpendicular to other lines of the object. Section lines placed at 30° and 60° are common. Section lines that are more than 75° or less than 15° from horizontal should be avoided. Section lines should be drawn in opposite directions on adjacent parts (see Figure 6.25). For additional adjacent parts, any suitable angle can be used to make the parts appear clearly separate. The space between section lines can vary, depending on the size of the object, but the minimum space recommended by the ASME standard is .06 in. (1.5 mm) (see Figure 6.20). Figure 6.21 shows correct and incorrect applications of section lines. When a very large area requires section lining, you can use outline section lining as shown in Figure 6.22. This technique can be done

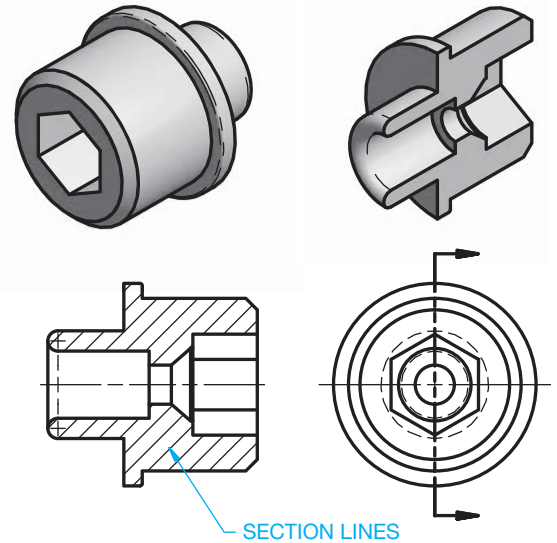


FIGURE 6.19 Section lines represent the material being cut in a sectional view.

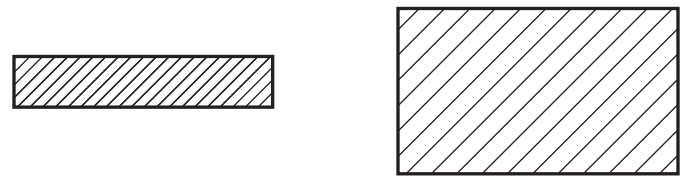


FIGURE 6.20 Space between section lines depends on the view size and scale. The minimum recommended section spacing is .06 in. (1.5 mm). © Cengage Learning 2012

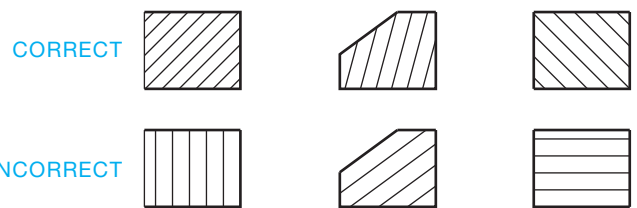


FIGURE 6.21 Correct and incorrect section-line use. © Cengage Learning 2012

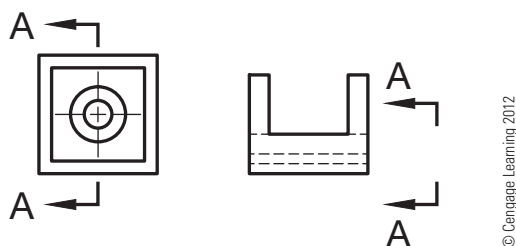


FIGURE 6.18 Simplified cutting- and view-plane lines. The dashes between the line ends are omitted.

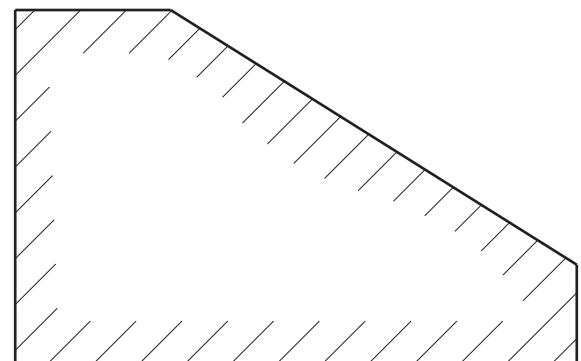


FIGURE 6.22 Using outline section lines.



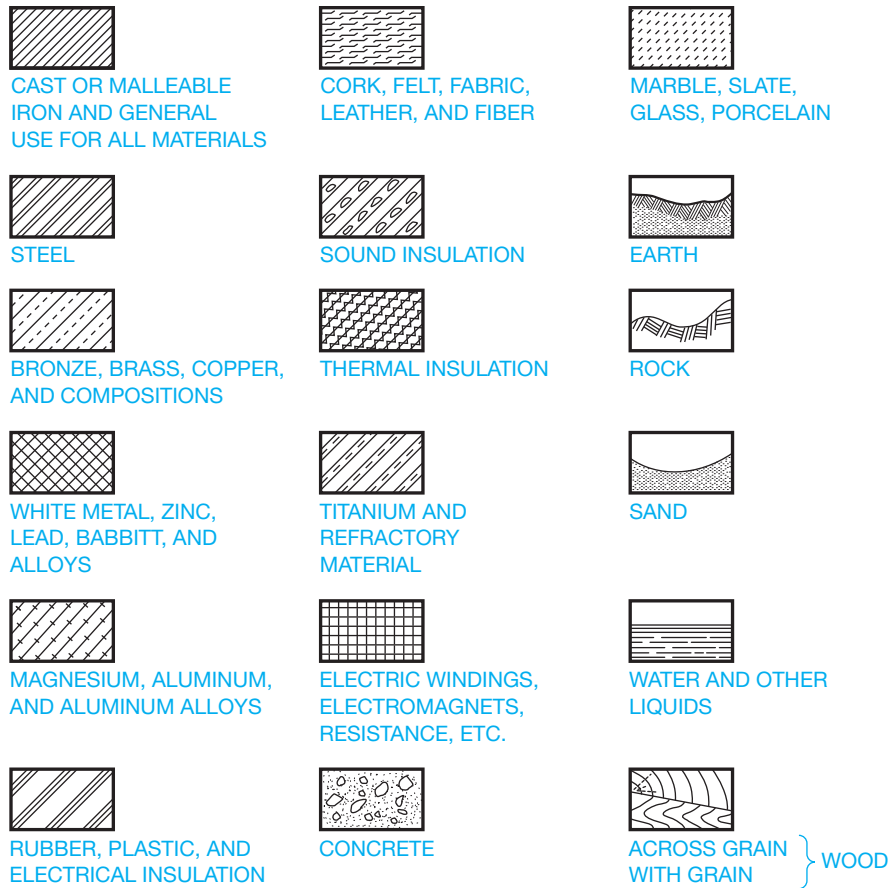


FIGURE 6.23 Coded section-line examples.

© Cengage Learning 2012

using CADD, but you may have to create a boundary offset from the object line within which you draw the section lines. The actual practice depends on your available CADD system tools.

The section lines shown in Figures 6.19 through 6.22 were all drawn as general section-line symbols. General section lines can be used for any material and are specifically used for cast or malleable iron. Coded section-line symbols, as shown in Figure 6.23, are not commonly used on detail drawings because the drawing title block usually identifies the type of material used in the part. Coded section lines can be used when the material must be clearly represented, as in the section through an assembly of parts made of different materials (see Figure 6.24). Very thin parts, less than .016 in. (4 mm) thick, can be shown without section lining. Only the outline is shown in this application. This option is often used for a gasket in an assembly as shown in Figure 6.25.

Dimensions and text should be kept out of the sectional view, but the section lines are omitted around the text when it is necessary to have text in a sectional view.

CADD programs normally allow you to select from a variety of available section-line options. You should be able to match the desired ASME standard section-line symbol. The CADD system allows you to set the section-line type, spacing, and angle. Section lines are normally set up on a specific layer and with a specific color so they stand out clearly on the drawing. Section lines are very easy to draw with CADD, because all you have

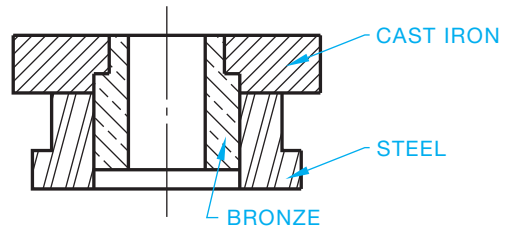


FIGURE 6.24 Coded section lines in assembly representing different materials used for each part in the assembly.

© Cengage Learning 2012

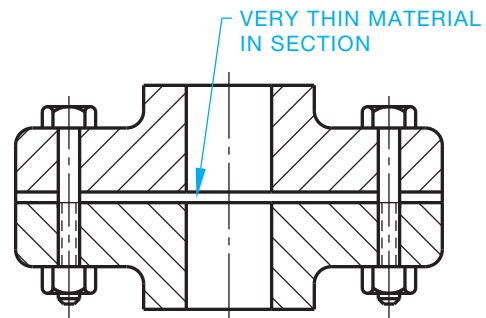


FIGURE 6.25 Very thin material in section can be drawn without section lines.

© Cengage Learning 2012

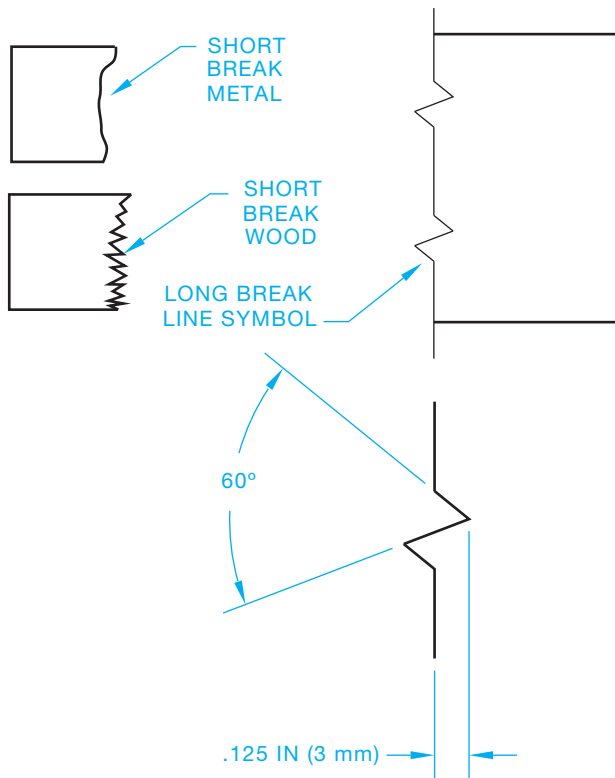
to do is select the object to be sectioned or pick a point inside of the area to be sectioned, or, in some cases, section lines are automatically placed when a section view is drawn. Normally, the object to be sectioned must be a closed geometric shape without any gaps in the perimeter. Some CADD systems also allow you to place section lines in an area that is not defined by an existing geometric shape.

### Break Lines

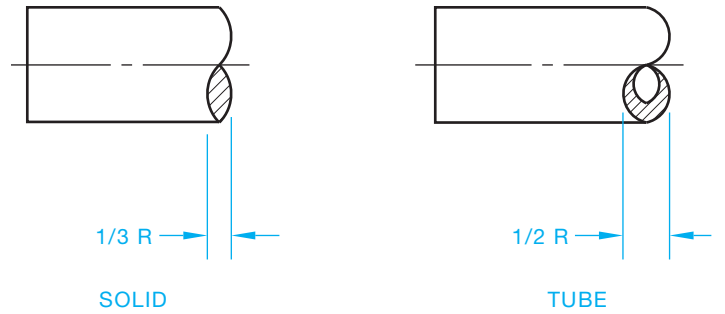
There are two types of **break lines**: short and long. Break lines are used to shorten the length of a long object or part or to provide a partial view of a feature. The thick, short break is very common on detail drawings, although the thin, long break can be used for breaks of long distances at your choice (see Figure 6.26). Short break lines were drawn freehand when using manual drafting. The CADD system should use a line style that closely duplicates a freehand line. Long break lines are drawn with a long break symbol spaced throughout the length of the line. Other conventional breaks can be used on cylindrical features as in Figure 6.27. Additional coverage of break line use is found in Chapter 12, *Sections, Revolutions, and Conventional Breaks*.

### Phantom Lines

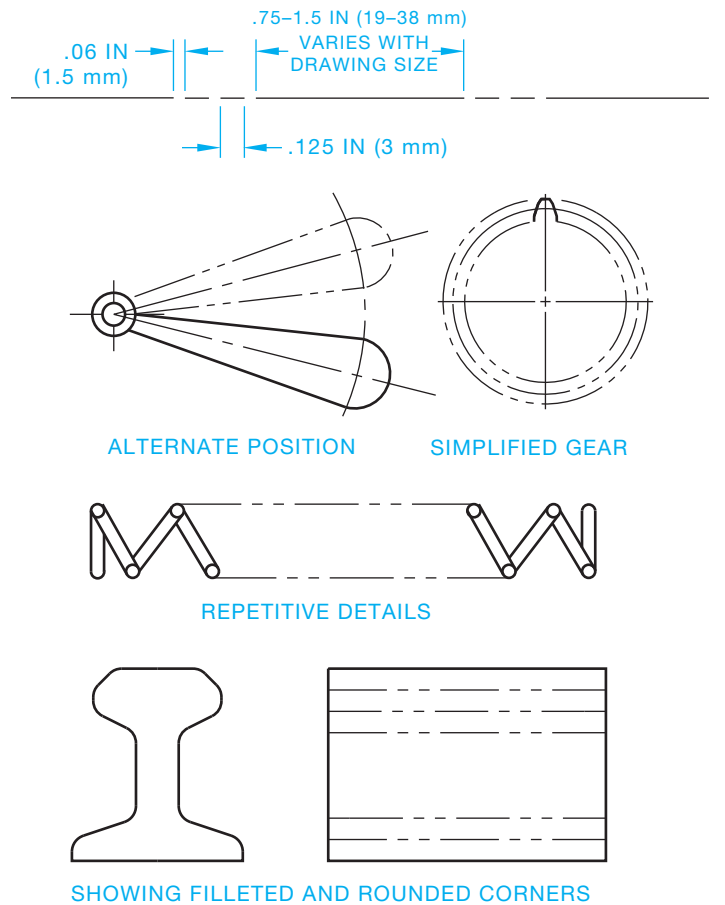
**Phantom lines** are thin lines made of one long and two short dashes alternately spaced. Phantom lines are used to identify



**FIGURE 6.26** Long and short break lines. The long break symbol is properly drawn as shown.



**FIGURE 6.27** Cylindrical conventional breaks. © Cengage Learning 2012



**FIGURE 6.28** Phantom line representation and example. © Cengage Learning 2012

alternate positions of moving parts, adjacent positions of related parts, repetitive details, or the contour of filleted and rounded corners (see Figure 6.28).

### Chain Lines

**Chain lines** are thick lines of alternately spaced long and short dashes used to indicate that the portion of the surface, next to the chain line receives specified treatment (see Figure 6.29). Chain lines are also used in projected tolerance zone applications described in Chapter 13, *Geometric Dimensioning and Tolerancing*.

© Cengage Learning 2012

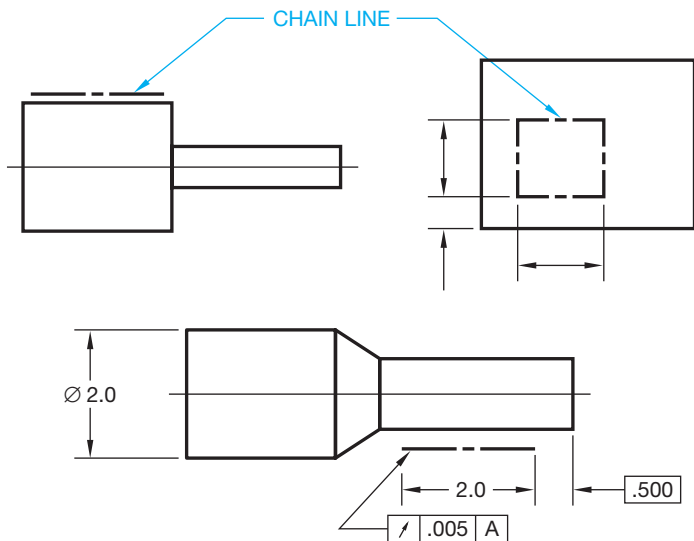


FIGURE 6.29 Chain lines. © Cengage Learning 2012

## Stitch Lines

There are two types of acceptable **stitch lines**. One is drawn as thin, short dashes, the other as .01 in. (0.3 mm) diameter dots spaced .12 in. (3 mm) apart. Stitch lines are used to indicate the location of a stitching or sewing process as shown in Figure 6.30.

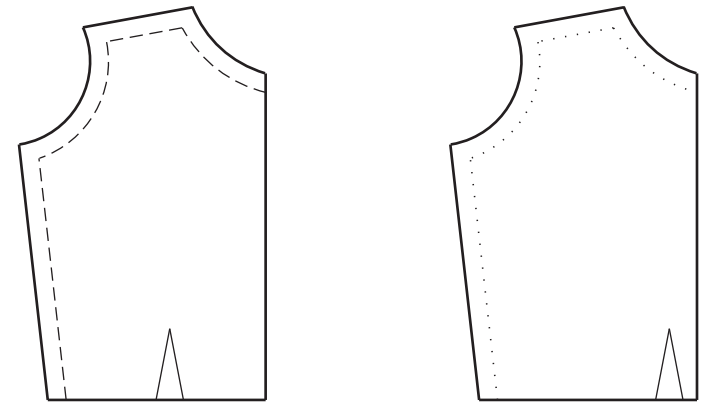


FIGURE 6.30 Stitch lines. © Cengage Learning 2012



## Manual Lines and Lettering

For information about drawing lines manually using pencil and ink, go to the Student CD, select **Supplemental Material, Chapter 6**, and then **Manual Lines and Lettering**.

## DRAWING LINES

Lines are fundamental to CADD drawings and models. Lines on a 2-D drawing are the graphic representation of the drawing characteristics. Lines for a 3-D model serve as geometry for the profiles, paths, and shapes necessary to build features, parts, and assemblies. The basics of drawing lines with CADD are applicable to all systems, regardless of the application. Drawing straight-line segments offers a primary introduction to CADD techniques. Most object drawing tools use point entry to locate and size geometry. One of the most basic examples of point entry is specifying the two end points of a line. Other tools and options, such as those for creating and editing geometric shapes, text, and dimensions, require similar input and methods. For example, specify points to locate the center and a point on the edge of a circle, and specify the points at opposite corners of a rectangle.

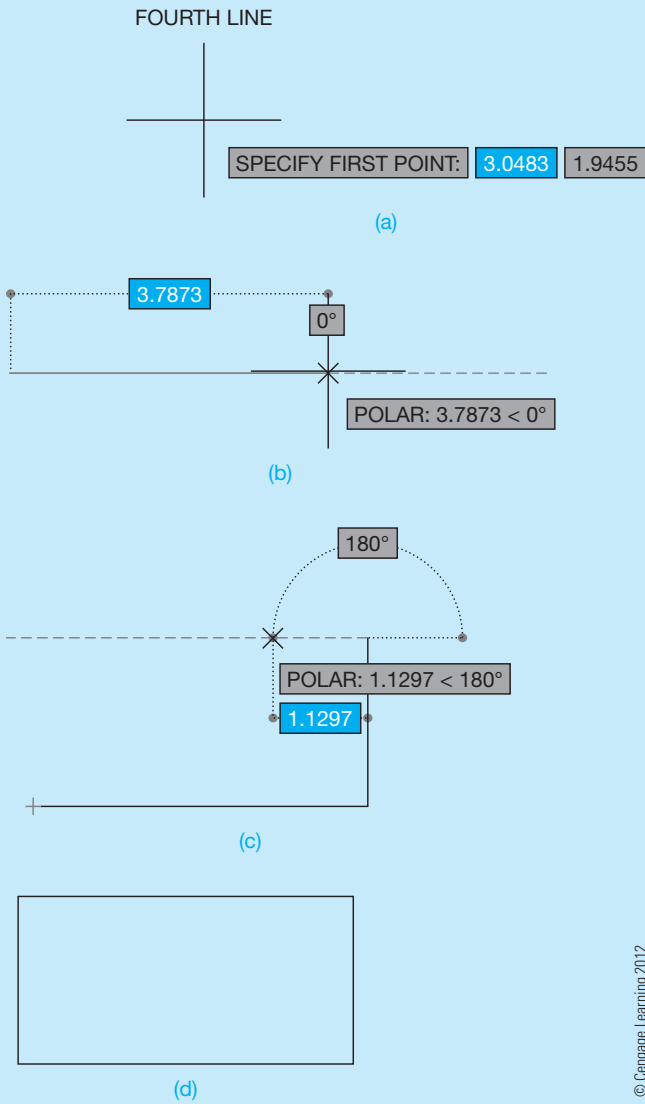
The basic process of drawing straight lines is similar for most CADD systems. To draw a line, access the appropriate command, such as LINE. The drawing area cursor appears as a crosshair, wand, or point, depending on the CADD program. When you move the pointer, the cursor moves. Some systems may display the coordinates of the cursor location on the screen. These values change as you move the pointer (see Figure 6.31a). Use the cursor to

specify a starting point, which is the first line end point. As you move the cursor, some software may display a rubber-band line connecting the first point and the crosshairs and other drawing aids that allow you to draw accurately (see Figure 6.31b). Specify another point to draw a straight line between the first and second end points. Continue locating points to connect a series of line segments (see Figure 6.31c). Then use an appropriate method to exit the LINE command and complete the object as shown in Figure 6.31d.

## Drawing Aids and Constraints

Most CADD systems provide specific tools and options that assist in drawing accurate lines. Figure 6.31 shows examples of drawing aids that allow you to draw an accurate 4 unit  $\times$  2 unit rectangle quickly. Another example is the concept of assigning **constraints** to lines. Figure 6.32a shows an **unconstrained** line drawn without considering the location of the line in space and the length and angle of the line. Figure 6.32b shows adding a coincident **geometric constraint** to the line to locate the end point of the line at the **origin**, or the coordinates where  $X = 0$ ,  $Y = 0$ , and  $Z = 0$ . Figure 6.32b also shows adding a horizontal geometric constraint to the line to specify the line as horizontal. Figure 6.32c shows defining the length of

(Continued)

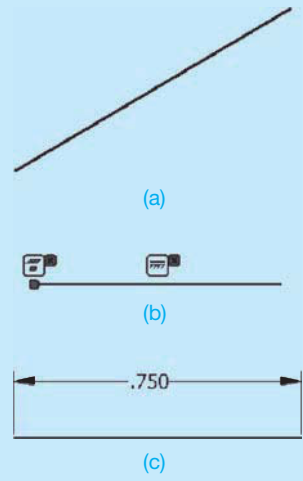


**FIGURE 6.31** Using a CADD program to draw an object with lines one point at a time. (a) Specify the first end point. (b) Specify the second end point. (c) Specify additional end points to draw connected lines. (d) A rectangle drawn using straight line segments.

the line using a **dimensional constraint**. Constraints are useful because they place limits on geometry to preserve design intent, and they help form geometric constructions. Consider using constraints to help maintain relationships between objects in a drawing, especially during the design process, when changes are often frequent.

**LINE FORMAT**

Several CADD tools and options simplify and automate applying correct line standards and format. However, you are still responsible for using appropriate CADD tools



**FIGURE 6.32** A very basic example of using constraints to define the size and location of a line. (a) An unconstrained line. (b) Adding geometric constraints. (c) Adding a dimensional constraint.

and developing and adjusting settings that allow the software to assist you in applying correct styles and standards. Most CADD systems allow you to assign properties to objects. General properties include items such as the type of the object, color, line type, and thickness, or line weight. Object properties provide several functions, such as representing line conventions and controlling the display of objects. In some cases, the properties you assign to objects control how the software treats the object. For example, some programs may recognize a centerline as an axis or line of symmetry used for developing 3-D model features. Another example is a CADD system that recognizes lines specified as being for construction purposes only and does not use those lines in the display of the final drawing, for plotting, or for building 3-D model features.

**Layers**

The **layer**, or **overlay**, system is a common method for controlling line format with CADD. Layers separate different objects and elements of a drawing. For example, draw all visible lines using a layer named “Visible” that uses a black color, a continuous or solid line type, and a .02 in. (0.6 mm) line weight. Draw hidden lines using a layer named “Hidden” that uses a green color for contrast, a hidden or dashed line type, and a .01 in. (0.3 mm) thickness. You can display both layers to show the complete drawing with hidden features or hide the Hidden layer to show only the visible object lines.

(Continued)

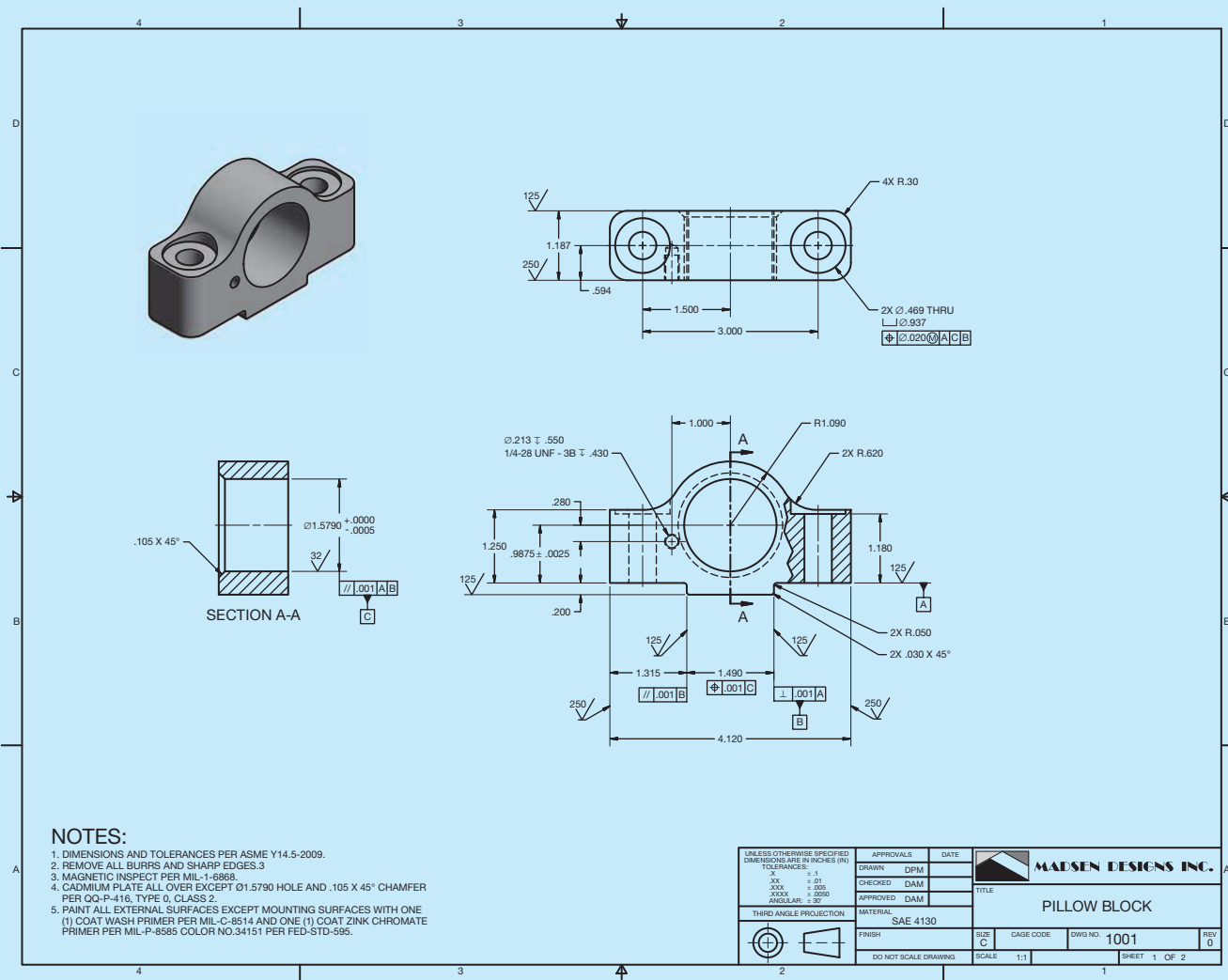
The following is a list of ways you can use layers to increase productivity and add value to a drawing:

- Assign each layer a unique color, line type, and line weight to correspond to line conventions and help improve clarity.
- Make changes to layer properties that immediately update all objects drawn on the layer.
- Disable selected layers to decrease the amount of information displayed on screen or to speed screen regeneration.
- Plot each layer in a different color, line type, or line weight, or set a layer not to plot at all.
- Use separate layers to group specific information.
- Create different drawings from the same drawing file by controlling layer visibility to separate or combine drawing information.

The method you use to assign line format to objects varies, depending on the CADD software and drawing process.

The best practice for using layers during traditional 2-D drafting is to make the appropriate layer current or active before you begin drawing the corresponding objects. However, CADD offers convenient tools for changing the layer and other properties assigned to existing objects when necessary.

Some CADD software that combines 3-D solid modeling with parametric 2-D drawing capabilities automatically applies specific line format when you extract views from a model and when you use specific drafting tools. Figure 6.33 shows an example of a drawing created by referencing an existing solid model. When you place the front and top views, the software recognizes visible and hidden objects and assigns predefined layers accordingly. Centerlines automatically appear to represent the centers of cylindrical features. Tools that allow you to create the section views apply predefined line format to cutting-plane, break, and section lines. Dimension and text tools reference appropriate layers when you add dimensions and text.



Courtesy Madsen Designs Inc.

FIGURE 6.33 Some CADD software applies predefined format to lines when you extract views and add dimensions and text.

## LETTERING

Information on drawings that cannot be represented graphically by lines can be presented by lettered dimensions, notes, and titles. *Lettering* refers to all letters and numbers on drawings and related documents. It is extremely important for these lettered items to be exact, reliable, and entirely legible in order for the reader to have confidence in them and have no doubt as to their meaning. This is especially important when using reproduction techniques that require a drawing to be reduced in size using photocopy or microfilm.

### STANDARDS

**ASME** The standard for lettering was established in 1935 by the American National Standards Institute (ANSI). This standard is now conveyed by the American Society of Mechanical Engineers document ASME Y14.2, *Line Conventions and Lettering*. Letters and numbers should be opaque and clearly spaced. Lettering can be vertical or inclined, but only one style should be used throughout the drawing. Uppercase letters are used on drawings unless lowercase letters are required for a specific application. The lettering style used when revising a drawing should match the original drawing lettering style.

## LETTERING ON ENGINEERING DRAWINGS

The standardized lettering format was developed as a modified form of the Gothic letter font. The term **font** refers to a complete assortment of any one size and style of letters. The simplification of the Gothic letters resulted in elements for each letter that became known as single-stroke Gothic lettering. The name sounds complex, but it is not. The term *single stroke* comes from the fact that each letter is made up of a single straight or curved line element that makes lettering easy to draw and clear to read. There are upper- and lowercase, vertical, and inclined Gothic letters, but industry has become accustomed to using vertical uppercase letters as the standard (see Figure 6.34). The ASME Y14.2 standard refers to words and numbers on a drawing as lettering. The term *lettering* is called **text** in CADD. The term **attribute** is also used in CADD



© Cengage Learning 2012

**FIGURE 6.34** Vertical, uppercase, single-stroke, Gothic-style letters and numbers.

when referring to text on a drawing or text associated with drawing symbols. CADD text styles should be used that most closely duplicate the original Gothic font. Common text styles that accomplish this use Arial, Century Gothic, RomanS, or SansSerif font. The specific font used should comply with your school or company standards.

Adding text to a CADD drawing is one of the most efficient and effective tasks associated with computer-aided drafting because the usually tedious task of freehand lettering is not involved. The process of placing text varies, depending on the CADD system, the commands used to generate the text, and the purpose of the text. However, the typical approach to adding text is to define and select a text style, specify the location for the text, and type characters on the keyboard.

## LETTERING NUMBERS

The following gives a basic description of how numbers are displayed on drawings. Detailed information about numbers and dimensioning is provided in Chapter 10, *Dimensioning and Tolerancing*, and in chapters related to specific drafting disciplines throughout this textbook. Metric units expressed in **millimeters** or U.S. customary units expressed in **decimal inches** are considered the standard units of linear measurement on engineering documents and drawings. When all dimensions are either in millimeters or inches, the general note, UNLESS OTHERWISE SPECIFIED, ALL DIMENSIONS ARE IN MILLIMETERS (or INCHES), should be placed on the drawing. Inch dimensions should be followed by *IN* on predominantly millimeter drawings, and *mm* should follow millimeters on predominantly inch-dimensioned drawings.

### Decimal Points

When a dimension value has a decimal point, the decimal point should be uniform, dense, and large enough to be clearly visible. The decimal point should be placed in line with the bottom edge of the text. When millimeter dimensions are less than 1, a zero precedes the decimal, as in 0.8. Decimal inch dimensions do not have a zero before the decimal, as in .75. Neither the decimal point nor a zero is shown when the metric dimension is a whole number, such as in the example 24. In addition, when the metric dimension is greater than a whole number by a fraction of a millimeter, the last digit to the right of the decimal point is not followed by a zero, as in 24.5. This is true unless tolerance numerals are involved, which is described in detail in Chapter 10, *Dimensioning and Tolerancing*. Figure 6.35 shows



**FIGURE 6.35** Examples of options for using decimal points. © Cengage Learning 2012



FIGURE 6.36 Examples of options for fractions. © Cengage Learning 2012

examples of metric and inch dimension values using decimal points.

## Fractions

Fractions are commonly used on architectural, structural, and other construction-related drawings. Fractions are used on engineering drawings, but they are not as common as decimal inches or millimeters. Fraction dimensions generally mean a larger tolerance than decimal numerals. When fractions are used on a drawing, the fraction numerals should be the same size as other numerals on the drawing. The fraction bar should be drawn in line with the direction the dimension reads. A visible space is recommended between the bar and the fraction numerals. The fraction bar can also be placed diagonally, depending on your school or company standards. The fraction bar is often placed diagonally when part of a general note, material specification, or title. When using CADD, the text style determines the fraction bar's orientation. You can easily set the fraction numbers to the correct height and have the fraction bar in any desired position. Figure 6.36 shows options for fractions.

## OTHER LETTERING STYLES

Most manufacturing companies use vertical uppercase text that complies with the ASME Y14.2 standard. Other text styles can be used, but the specific style used depends on the school or company standards and sometimes the drafting discipline. The structural drafting field, for example, often uses inclined uppercase text on their drawings. Some civil drafting applications also use inclined text. The architectural drafting discipline sometimes uses a text style that closely duplicates the artistic flair found in freehand architectural lettering. However, the United States National CAD Standard recommends a vertical, uppercase Gothic-style font such as SansSerif.

## Inclined Lettering

Some companies prefer inclined lettering. The recommended slant for inclined text is 68° to the right from horizontal.



FIGURE 6.37 Uppercase inclined letters and numbers.

Structural drafting is one field or discipline where inclined text is commonly found on drawings. Some civil drafting applications also use inclined text. Figure 6.37 shows slanted uppercase letters.

## Lowercase Lettering

Lowercase letters can be used, but they are very uncommon in mechanical drafting. Lowercase letters can be used in engineering documents such as specifications. Civil or map drafters use lowercase lettering for some practices. Figure 6.38 shows lowercase lettering styles.

## Architectural Styles

Architectural lettering can be more varied in style than the recommended ASME text style; however, neatness and readability remain essential. The United States National CAD Standard specifies that the recommended architectural text style is the SansSerif font that closely duplicates the ASME-recommended text font. Historically, architectural drafters used a unique artistic lettering style that is different from the vertical, uppercase Gothic style commonly used in engineering drafting. A similar CADD text style is available using fonts such as StylusBT, ArchiText, CountryBlueprint, or CityBlueprint. Although these fonts closely duplicate the traditional artistic lettering style, they should only be used if they

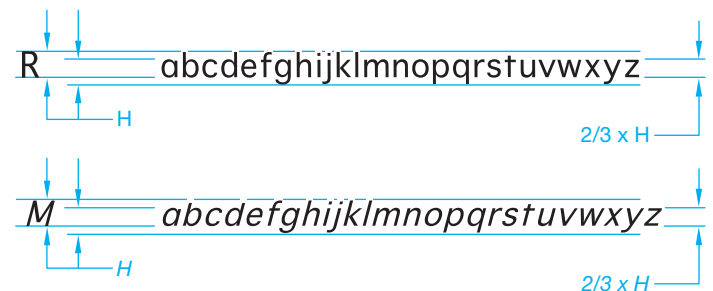


FIGURE 6.38 Lowercase lettering. © Cengage Learning 2012

# MAIN FLOOR PLAN

1/4" = 1'-0"  
SansSerif

# LIVING ROOM

12<sup>6</sup> × 14<sup>0</sup>  
ArchiText

ABCDEFGHIJKLMN  
OPQRSTUVWXYZ  
1234567890  
StylusBT

© Cengage Learning 2012

FIGURE 6.39 Architectural lettering examples.

match the text style required by your school or company (see Figure 6.39).

## LETTERING LEGIBILITY

The letters in words on a drawing should be spaced so the background area between the letters is approximately equal, and individual words should be clearly separated. When using CADD, the text you enter generally meets this requirement, and applying one space between words provides the correct separation. Lettering must be dark, crisp, and opaque for the best possible reproducibility. The primary objective is for lettering on a drawing to produce fully legible copies.

According to the ASME standard, letters in words should be spaced so the background areas between letters are approximately the same and individual words are clearly separated. The space between two numerals with a decimal point between should be a minimum of two-thirds the height of the lettering. This practice is automatically controlled by the CADD software, but your CADD text style can be set to provide clear readability. The vertical space between lines of lettering should be no more than the height of the lettering or no less than half the height of the lettering.

### STANDARDS

**ASME** According to ASME Y14.2, the minimum recommended lettering height depends on the drawing-sheet size and the application on the drawing. Typically, lettering height on engineering drawings is .12 in. (3 mm). All dimension numerals, notes, and other lettered information should be the same height except for titles, drawing numbers, section and view letters, and other captions, which are .24 in. (6 mm) high.

The following table gives the recommended minimum lettering heights for different elements of the drawing based on drawing-sheet sizes.

Sheet Elements	Minimum Letter Heights, IN	Drawing Sizes, IN	Letter Heights, METRIC (mm)	Drawing Sizes, METRIC
Drawing title, sheet size, CAGE code, drawing number, revision letter in the title block	.24	D, E, F, H, J, K	6	A0, A1
Drawing title, sheet size, CAGE code, drawing number, revision letter in the title block	.12	A, B, C, G	3	A2, A3, A4
Zone letters and numbers in borders	.24	All sizes	6	All sizes
Drawing block headings	.10	All sizes	2.5	All sizes
All other characters	.12	All sizes	3	All sizes

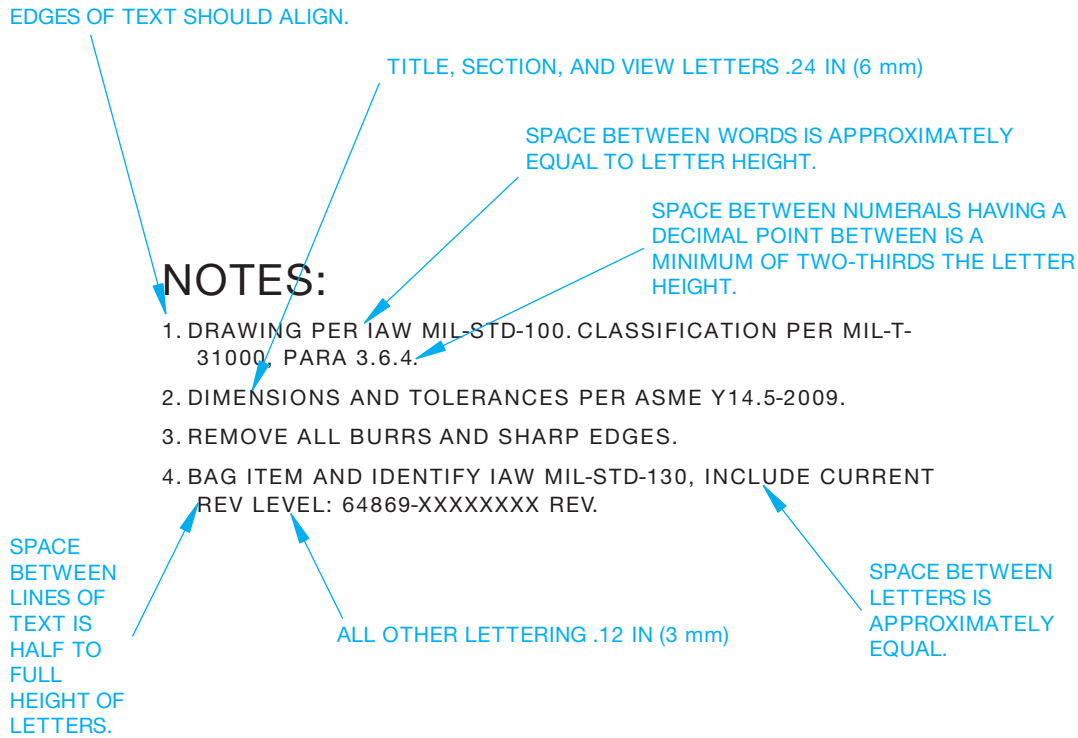
Notes should be lettered horizontally on the sheet. When notes, sentences, or dimensions require more than one line, the vertical space between the lines should be a minimum of one-half the height of letters. The maximum recommended space between lines of lettering is equal to the height of the letters. Some companies prefer to use the minimum space to help conserve space, and other companies prefer the maximum space for clarity. Placing text in CADD is just like using a word processor. The text style and line spacing can be adjusted to meet specific requirements. Figure 6.40 shows an example of notes that are commonly placed in the lower left corner of the sheet on an engineering drawing. Additional specific information about notes is provided in Chapter 10, *Dimensioning and Tolerancing*.



### Manual Lines and Lettering

For information about freehand lettering and using manual lettering instruments, go to the Student CD, select **Supplemental Material**, select **Chapter 6**, and select **Manual Lines and Lettering**.





© Cengage Learning 2012

FIGURE 6.40 Spacing of letters and words in notes and between lines of lettering.

## TEXT

Lettering is called text when using CADD. Adding text to a CADD drawing is one of the most efficient and effective tasks associated with computer-aided drafting because the usually tedious task of freehand lettering is eliminated. When correct drafting practices and text settings are used, text created using CADD offers the following benefits:

- Characters (words and numbers) are drawn at constant shapes and sizes.
- Symbols containing complex shapes are quickly added to lines of text.
- Text styles and standards control text appearance.
- Text is created with high speed, accuracy, and legibility.
- Text can be easily reproduced and modified.
- Easy copy, cut, and paste operations are possible.
- Specialized tools and options can be used such as spell-checking, fields, attributes, and hyperlinks.

The process of placing text varies, depending on the CADD system, the commands used to generate the text, and the purpose of the text. However, the typical approach to adding text is to define and select a text style,

specify the location for the text, and type characters on the keyboard in the **text editor**. The text editor is the area provided by the text system where you type and adjust text. Some CADD software offers a basic text editor with limited options. Other programs include a fully functional text editor that is similar to word processing software, with options for extensive paragraph formatting, lists, symbols, and columns.

### Text Styles

Most CADD programs contain standard, or default, text styles. The term **default** refers to any value that is maintained by the computer for a command or function that has variable parameters. For example, the default text height might be .12 in. (3 mm). Though the default text style can be used to add drawing text, typically a new or modified style is more appropriate. CADD systems have multiple text options that allow you to create a variety of text styles based on the nature of the drawing and the specified drafting standards. Font, height, width, and incline angle are a few of the characteristics that can be applied to text. You can change the style of existing text or create new text with a modified style. Figure 6.41 shows examples of text created using specific text styles.

(Continued)

## DIMENSIONS AND TOLERANCES PER ASME Y14.5–2009.

ASME Y14.2 standard: vertical UPPERCASE, Romans font

BEND DOWN 90° R.50

ASME Y14.2 standard: vertical UPPERCASE, Arial font

REMOVE ALL BURRS AND SHARP EDGES.

ASME Y14.2 standard: vertical UPPERCASE, Century Gothic font

SIMPSON LCC5.25-3.5 TYP

United States National CAD Standard: vertical UPPERCASE, SanSarif font

HOOD W/ FAN, VENT TO OUTSIDE AIR

Traditional architectural format: vertical UPPERCASE, Stylus BT font

ALL FRAMING LUMBER TO BE DFL #2 OR BETTER

Traditional architectural format: vertical UPPERCASE, CountryBlueprint font

TYP EACH END TWO FLANGES

ASME Y14.2 standard variation: inclined UPPERCASE, Arial font

*Mississippi River*

River identification on a map: inclined lowercase, SanSarif font

© Cengage Learning 2012

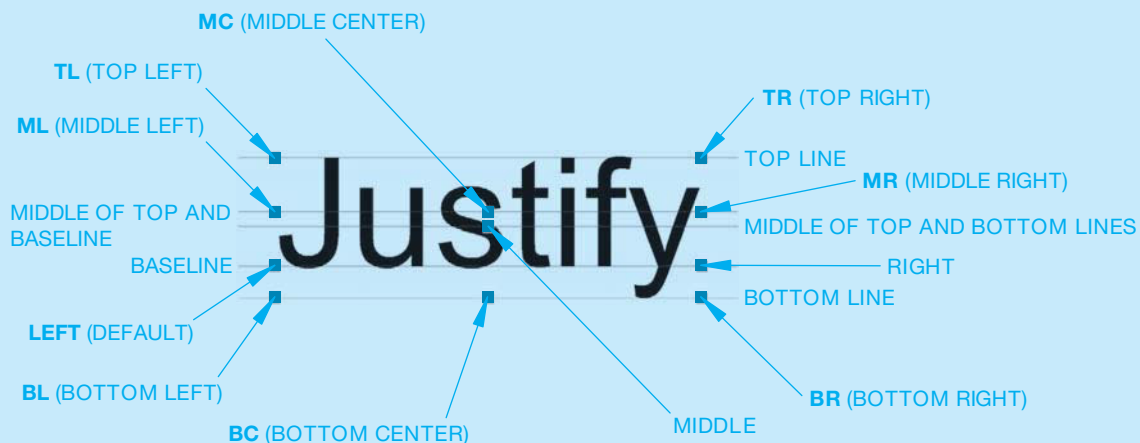
**FIGURE 6.41** Samples of text created using different CADD text styles.

## Locating Text

It is your responsibility as the drafter to place notes, dimensions, and other drawing information according to appropriate drafting standards. Though some CADD systems automatically place text in certain predefined locations, such as in the cells of a parts list and title block, in most situations you must decide exactly where text is located or at least set up the options required for an automated text placement system to function properly. Most CADD systems provide coordinate entry, drawing aids, and constraints that allow you to locate text accurately. You

also have the ability to move, rotate, and further edit text as needed.

You usually have the option to **justify** or align the margins or edges of text. For example, left-justified text aligns along an imaginary left border. Figure 6.42 shows common justification points on a single line of text to further position text, or the text editor boundary using one of several points on the lettering. Justify text to control the arrangement and location of text within the text editor. Justification provides flexibility for determining the location and arrangement of text. Justification also determines the direction of text flow.



**FIGURE 6.42** Common justification options available for text objects or text editors. The difference between some options is only evident when you use values that extend below the baseline, such as the letter y in the word *Justify*.

© Cengage Learning 2012

## MODEL TEXT

You can apply text to models for a variety of applications, typically to replicate text found on an actual product. Model text usually begins as a 2-D text object that you can use to create specialized features such as embossments, engravings, decals, stamps, and standard features such as extrusions. Model text appears in extracted 2-D views, and additional text tools and options are often available in the 2-D drawing work environment. Figure 6.43 shows an example of text applied to a solid model as a decal feature to replicate printing. Figure 6.44 shows an example of text applied to a solid model as an embossment. Notice in Figure 6.44 how the text forms along a circle, which is easy to accomplish using CADD.



**FIGURE 6.43** Text applied to a solid model to replicate printing.



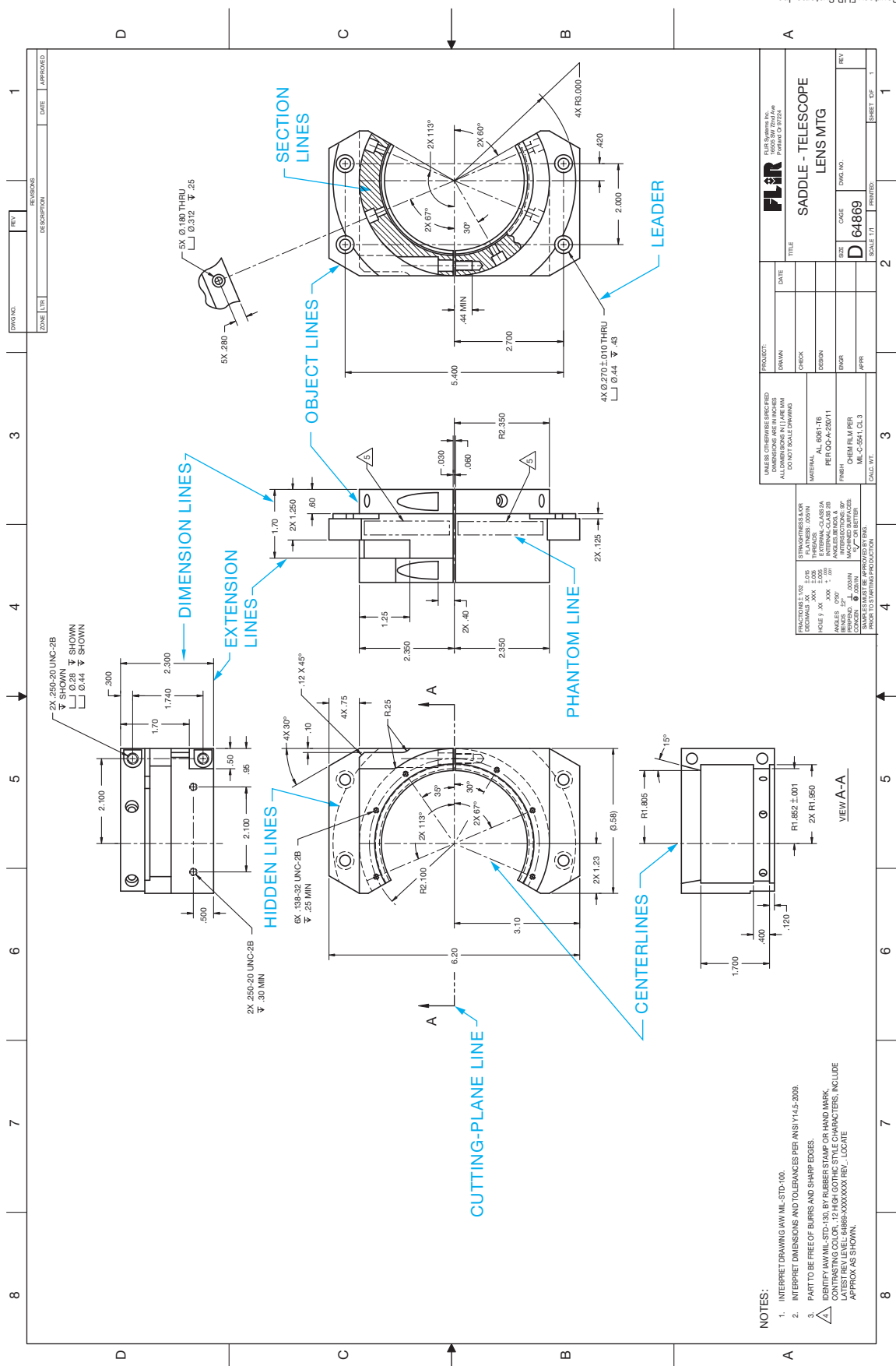
**FIGURE 6.44** Text applied to a solid model as an embossment. Notice how the text forms along a circle, which is easy to accomplish using CADD.

## PROFESSIONAL PERSPECTIVE

### PULLING IT ALL TOGETHER

Try to find as many actual industry drawings as you can to look at the line and lettering standards and quality applied by each company. Look at the lines and identify as many line types as you can find. See how the drawing text matches the discussion and examples in this chapter. Many

of the industry drawings you see will have excellent quality and follow proper standards, although some may not have the best quality. The drawing in Figure 6.45 provides an example of line and lettering work that is commonly used in engineering drawing. The line types are labeled for your reference.



Courtesy FLIR Systems, Inc.

FIGURE 6.45 A real-world drawing with a variety of line types identified.

- NOTES:
1. INTERPRET DRAWING IAW MIL-STD-100.
  2. INTERPRET DIMENSIONS AND TOLERANCES PER ANSI Y14.5-2009.
  3. PART TO BE FREE OF BURRS AND SHARP EDGES.
- SURFACE FINISH (A) MIL-STD-100, BY RUBBER STAMP OR HAND MARK  
 CONTRASTING COLOR: 12 HIGH GOTHIC STYLE CHARACTERS, INCLUDE  
 LATEST REV LEVEL: 64869-XXXXXXX REV., LOCATE  
 APPROX. AS SHOWN.

## FRACTIONAL ARITHMETIC

The United States is one of the few countries of the world that does not commonly use a metric system of measurement. It is important for a drafter to be able to handle the arithmetic of both common fractions and decimal fractions. Determine the overall height of Figure 6.46 and the overall width of 15 of these pieces laid side to side.

The solution to overall height involves an addition of mixed numbers. Notice the use of a common denominator (16) to add the fractions:

$$2\frac{1}{16} + 1\frac{1}{4} + 2\frac{3}{8} = 2\frac{1}{16} + 1\frac{4}{16} + 2\frac{6}{16} = 5\frac{11}{16}$$

The solution to the width of 15 pieces requires multiplication of one width  $\times 15$ :

$$5\frac{7}{8} \times 15 = \frac{47}{8} \times \frac{15}{1} = \frac{705}{8} = 88\frac{1}{8} = 7.4\frac{1}{8}$$

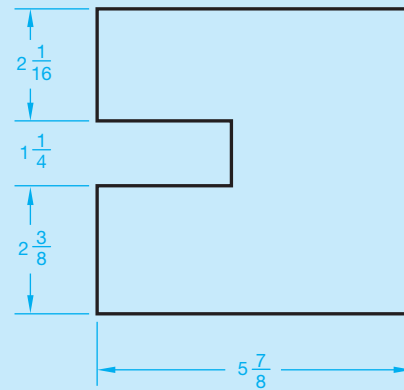


FIGURE 6.46 Fractionally dimensioned part.

© Cengage Learning 2012

## WEB SITE RESEARCH

Use the following Web sites as a resource to help find more information related to engineering drawing and design and the content of this chapter.

Address	Company, Product, or Service
<a href="http://www.adda.org">www.adda.org</a>	American Design Drafting Association and American Digital Design Association (ADDA International)
<a href="http://www.asme.org">www.asme.org</a>	American Society of Mechanical Engineers (ASME)
<a href="http://www.nationalcadstandard.org">www.nationalcadstandard.org</a>	United States National CAD Standard

# Chapter 6

## Chapter 6 Lines and Lettering Test



To access the Chapter 6 test, go to the Student CD, select **Chapter Tests and Problems**, and then **Chapter 6**. Answer the questions

with short, complete statements, sketches, or drawings as needed. Confirm the preferred submittal process with your instructor.

## Chapter 6 Lines and Lettering Problems

### Line Problems

#### Part 1: Problems 6.1 Through 6.11

- Using the selected engineer's layout as a guide only, create an original drawing following your course objectives. Make

a preliminary sketch if required by your instructor. Draw *only* the object lines, centerlines, hidden lines, and phantom lines as appropriate for each problem. Do not draw dimensions. Keep in mind that the engineer's sketches are rough and not meant for tracing.

2. Complete the drawing using the correct line standards described in this chapter.
3. Use an appropriately sized ASME sheet and use ASME sheet blocks. Complete the title block.
  - a. The title of the drawing is given.
  - b. The material the part is made of is given.
  - c. The drawing or part number is the same as the problem number.
  - d. Specify the scale and other unspecified information.
4. Make a print or plot of your drawing for checking unless otherwise specified by your instructor.

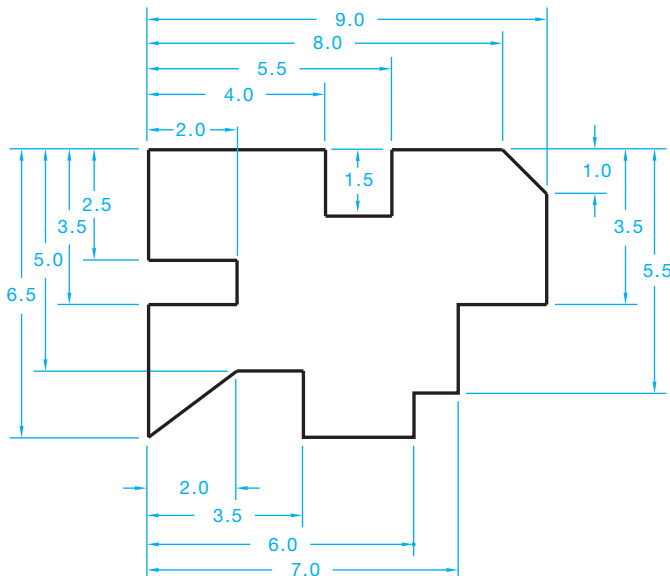
 **Drafting Templates**

To access CADD template files with predefined drafting settings, go to the Student CD, select **Drafting Templates**, and then select the appropriate template file. Use the templates to create new designs, as a resource for drawing and model content, or for inspiration when developing your own templates. The ASME-Inch and ASME-Metric drafting templates follow ASME, ISO, and related mechanical drafting standards. Drawing templates include standard sheet sizes and formats, and a variety of appropriate drawing settings and content. You can also use a utility such as the AutoCAD DesignCenter to add content from the drawing templates to your own drawings and templates. Consult with your instructor to determine which template drawing and drawing content to use.

**PROBLEM 6.1 Object lines (in.)**

Part Name: Plate

Material: .25 in. thick mild steel (MS)

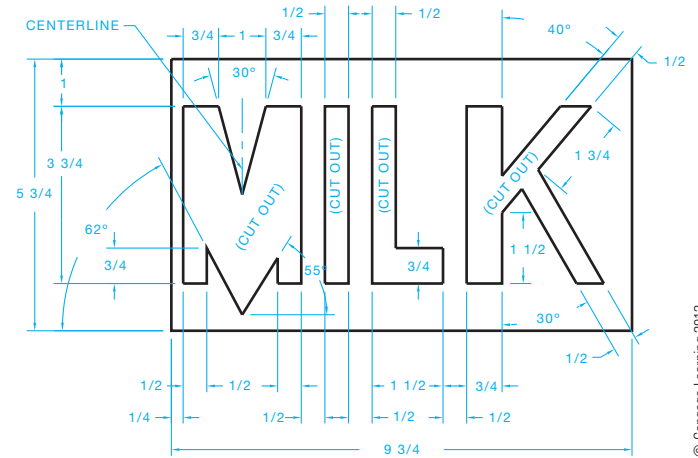


© Cengage Learning 2012

**PROBLEM 6.2 Straight object lines only (in.)**

Part Name: Milk Stencil

Material: .015 in. thick wax-coated cardboard. Used as a stencil to spray paint identification on crates of milk.

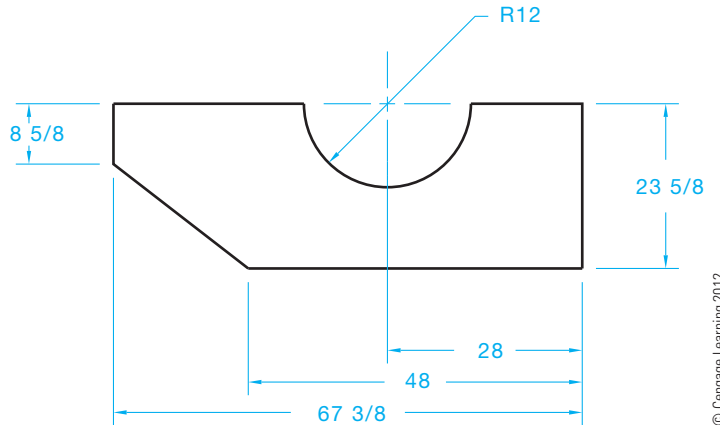


© Cengage Learning 2012

**PROBLEM 6.3 Arcs, object lines, and centerlines (in.)**

Part Name: Latch

Material: .25 in. thick mild steel

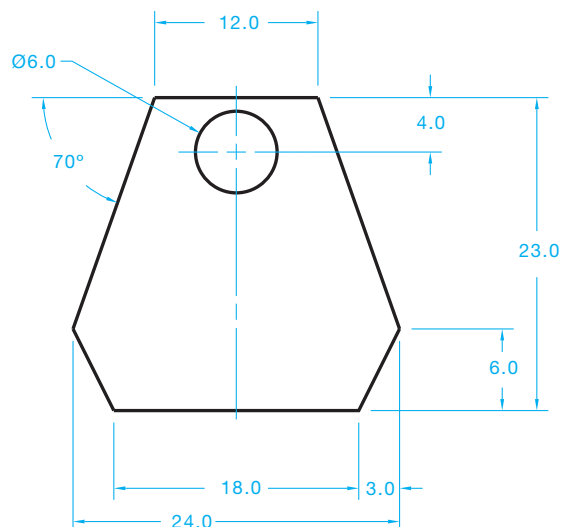


© Cengage Learning 2012

**PROBLEM 6.4 Circle, object lines, and centerlines (in.)**

Part Name: Stove Back

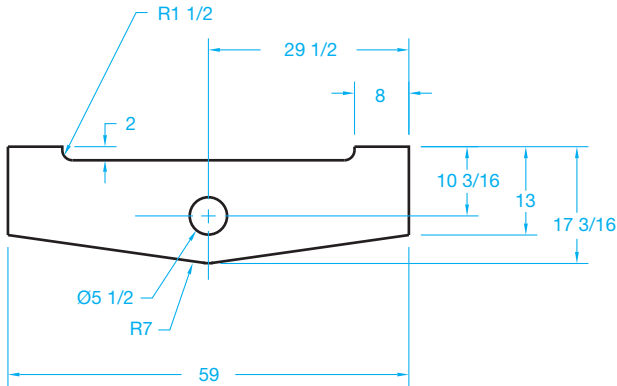
Material: .25 in. thick mild steel



© Cengage Learning 2012

**PROBLEM 6.5** Circle and arc object lines and centerlines (in.)

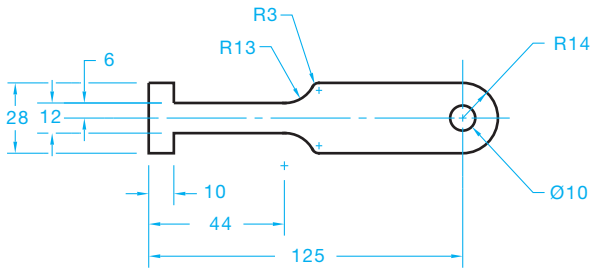
Part Name: Bogie Lock  
Material: .25 in. thick mild steel



© Cengage Learning 2012

**PROBLEM 6.6** Circle and arc object lines and centerlines (metric)

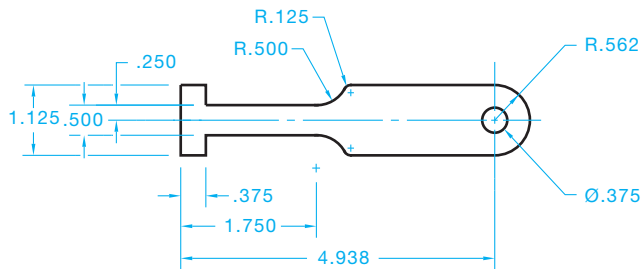
Part Name: T-Slot Cleaner  
Material: 6 mm-thick cold rolled steel (CRS)



© Cengage Learning 2012

**PROBLEM 6.7** Circle and arc object lines and centerlines (in.)

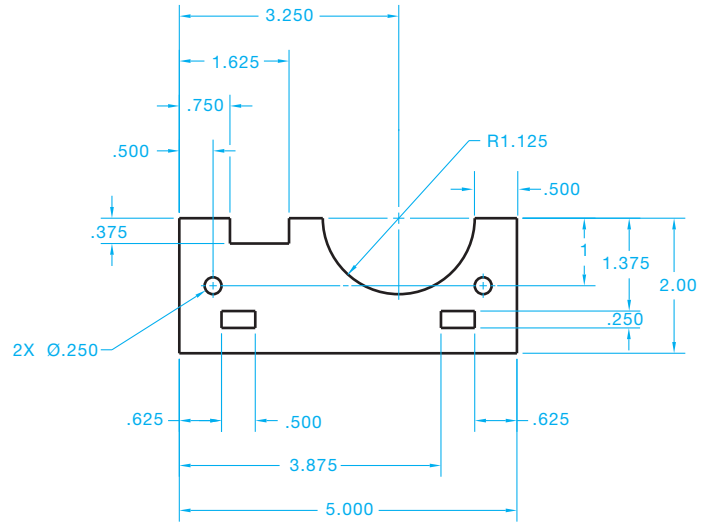
Part Name: T-Slot Cleaner  
Material: .25 in. thick cold rolled steel



© Cengage Learning 2012

**PROBLEM 6.8** Arcs, circles, and centerlines (in.)

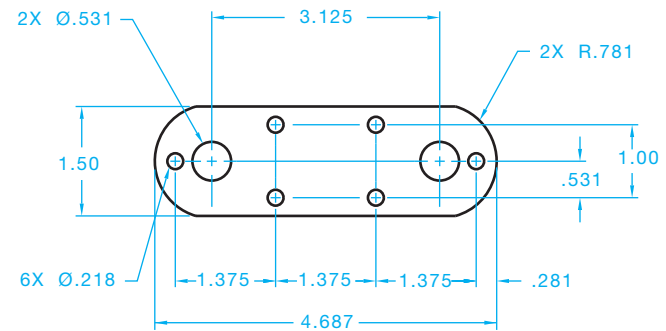
Part Name: Bracket  
Material: Stainless steel



© Cengage Learning 2012

**PROBLEM 6.9** Arcs, circles, and centerlines (in.)

Part Name: Bracket  
Material: Mild steel

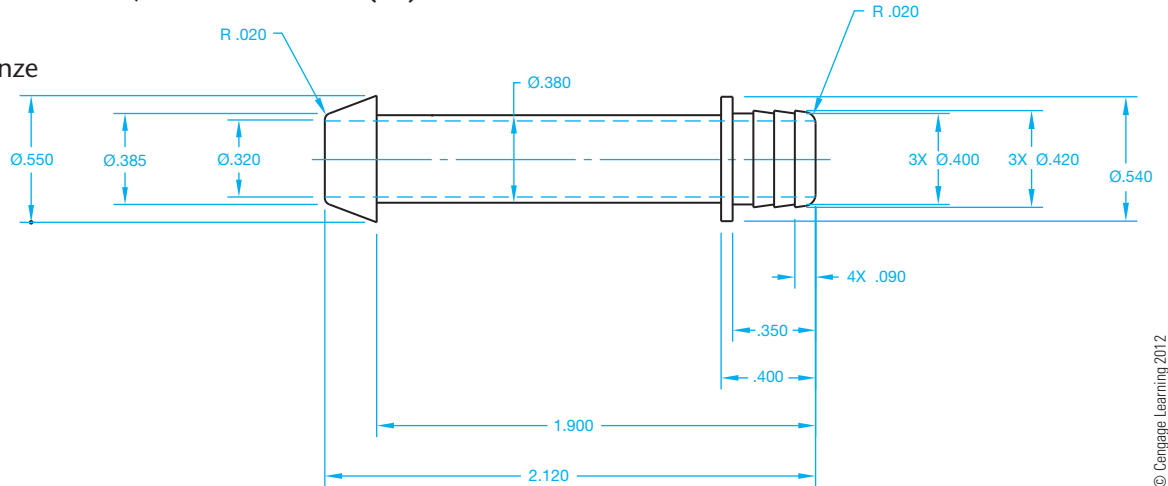


© Cengage Learning 2012

**PROBLEM 6.10** Arcs, centerlines, and hidden lines (in.)

Part Name: Pin

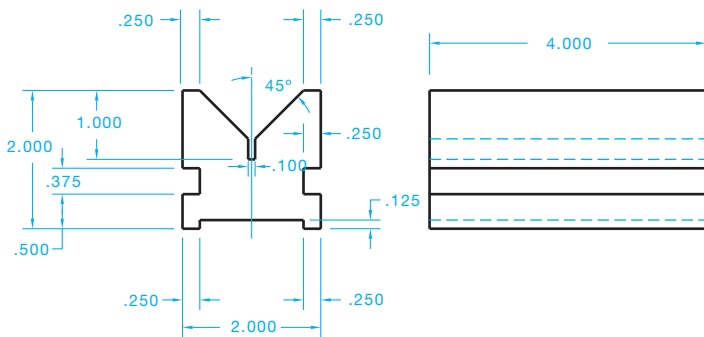
Material: Phosphor bronze



**PROBLEM 6.11** Multiviews (2 views), object lines, and hidden lines (in.)

Part Name: V-block

Material: 4.00 in. thick mild steel



© Cengage Learning 2012

**Lettering Problems**

**Part 2: Problems 6.12 Through 6.14**

Use a Gothic lettering style such as Arial, Century Gothic, RomanS, or SansSerif unless otherwise specified by your instructor. Use text .12 in. (3 mm) high. Space lines of lettering .12 in. apart unless otherwise specified by your instructor. Make a print or plot of your drawing for checking unless otherwise specified by your instructor.

**PROBLEM 6.12**

THE STANDARD FOR LETTERING WAS ESTABLISHED IN 1935 BY THE AMERICAN NATIONAL STANDARDS INSTITUTE. THIS STANDARD IS NOW CONVEYED BY THE AMERICAN SOCIETY OF MECHANICAL ENGINEERS DOCUMENT ASME Y14.2, *LINE CONVENTIONS AND LETTERING*. LETTERS AND NUMBERS SHOULD BE OPAQUE AND CLEARLY SPACED. LETTERING CAN BE VERTICAL OR INCLINED, BUT ONLY ONE STYLE SHOULD BE USED THROUGHOUT THE DRAWING. UPPERCASE LETTERS ARE USED ON DRAWINGS UNLESS LOWERCASE LETTERS ARE REQUIRED FOR A SPECIFIC APPLICATION. THE LETTERING STYLE USED WHEN REVISING A DRAWING SHOULD MATCH THE ORIGINAL DRAWING LETTERING STYLE.

**PROBLEM 6.13**

ACCORDING TO ASME Y14.2, THE MINIMUM RECOMMENDED LETTERING HEIGHT DEPENDS ON THE DRAWING-SHEET SIZE AND THE APPLICATION ON THE DRAWING. TYPICALLY, LETTERING HEIGHT ON ENGINEERING DRAWINGS IS .12 in. (3 mm). ALL DIMENSION NUMERALS, NOTES, AND OTHER LETTERED INFORMATION SHOULD BE THE SAME HEIGHT EXCEPT FOR TITLES, DRAWING NUMBERS, SECTION AND VIEW LETTERS, AND OTHER CAPTIONS, WHICH ARE .24 in. (6 mm) HIGH.

**PROBLEM 6.14**

**NOTES:**

1. UNLESS OTHERWISE SPECIFIED, ALL DIMENSIONS ARE IN MILLIMETERS.
2. DIMENSIONS AND TOLERANCES PER ASME Y14.5-2009.
3. REMOVE ALL BURRS AND SHARP EDGES.
4. ALL FILLETS AND ROUNDS R6.
5. CASEHARDEN 62 ROCKWELL C SCALE.
6. AREAS WHERE MATERIAL HAS BEEN REMOVED SHALL HAVE SMOOTH TRANSITIONS AND BE FREE OF SCRATCHES, GRIND MARKS, AND BURRS.
7. FINISH BLACK OXIDE.
8. PART TO BE CLEAN AND FREE OF FOREIGN DEBRIS.

**Math Problems**

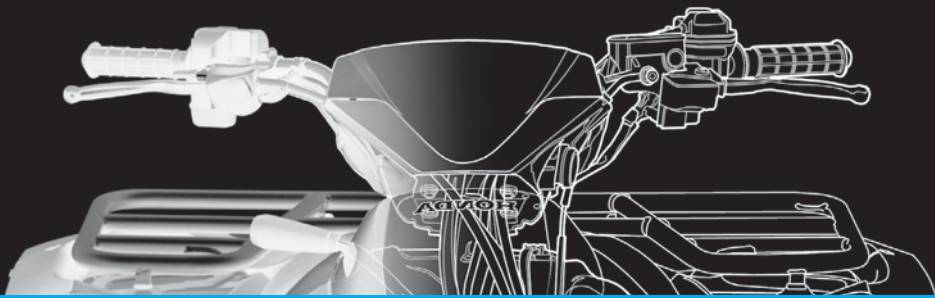
**Part 3: Problems 6.15 Through 6.19**



To access the Chapter 6 problems, go to the Student CD, select **Chapter Tests and Problems** and **Chapter 6**, and then open the math problem of your choice or as assigned by your instructor. Solve the problems using the instructions provided on the CD, unless otherwise specified by your instructor.

© Cengage Learning 2012





# CHAPTER

# 7

## Drafting Geometry

### LEARNING OBJECTIVES

After completing this chapter, you will:

- Draw parallel and perpendicular lines.
- Construct bisectors and divide lines and spaces into equal parts.
- Draw polygons.

- Draw tangencies.
- Draw ellipses.
- Solve an engineering problem by making a formal drawing with geometric constructions from an engineer's sketch or layout.

## THE ENGINEERING DESIGN APPLICATION

You should always approach an engineering drafting problem in a systematic manner. As an entry-level drafter, create sketches and written notes to plan how you propose to solve the problem. You are also often given engineering sketches and notes to interpret. Engineering sketches can be difficult to read. This is typical because engineers normally do not have the time or the skills to prepare a very neat and accurate sketch. Actual engineering sketches can be out of proportion and missing information. Dimensions on engineering sketches often do not comply with ASME or other related standards. Your responsibility is to convert the engineer's communication into a formal drawing that is accurate and drawn to proper standards. Do as much work as you can based on the given sketches and related information, but ask the engineer for help if you discover issues that are difficult to interpret or seem to be inaccurate. Much of the work you do in engineering drafting contains geometry and related geometric characteristics. Many geometric characteristics are basic, such as drawing circles and arcs, but many can be complicated, such as compound curves. Refer to the engineer's sketch shown in Figure 7.1 as you follow these layout steps:

- STEP 1** Do all preliminary layout work using construction lines on a construction layer or line type that will not display when finished. Begin by establishing the centers of the  $\varnothing 57$  and  $\varnothing 25.5$  circles and then draw the circles. The  $\varnothing$  symbol represents a circle's diameter.
- STEP 2** Draw the concentric circles of  $\varnothing 71.5$  and  $\varnothing 40$ .
- STEP 3** Locate and draw the  $6X R7.5$  arcs and then use tangencies to draw the  $R3$  radii arcs with the outside arcs.
- STEP 4** Draw the  $2X R7$  arcs tangent to the large inside arcs.
- STEP 5** Draw the centerlines for the  $6X \varnothing 7$  circles and then draw the circles from the established center

points. Draw all centerlines on the appropriate layer, such as the CENTERLINE layer.

- STEP 6** Complete all visible object lines by trimming and extending as needed. Make sure all visible lines are on the appropriate layer, such as the OBJECT layer. Erase unwanted features. Turn off or freeze the construction layer. Figure 7.2 shows the finished drawing.

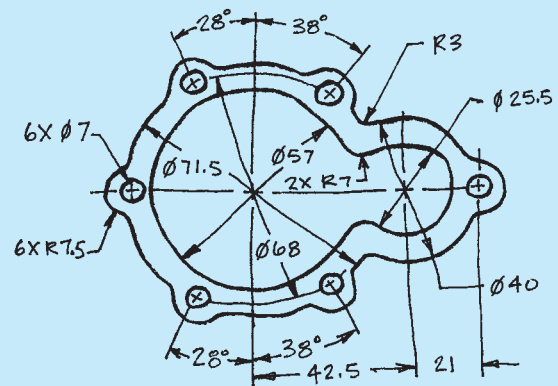


FIGURE 7.1 Engineer's sketch.

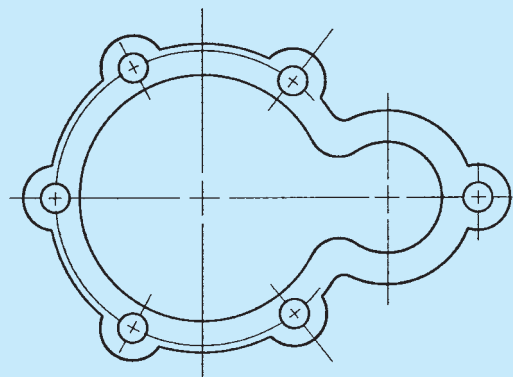


FIGURE 7.2 The complete drawing (without dimensions) for engineer's sketch shown in Figure 7.1.

## PREPARING A DRAWING FROM A SKETCH

Sometimes preparing a CADD drawing from an engineering sketch can seem overwhelming. Other times you may find that you could have used other tools, techniques, commands, or procedures to create a drawing in less time. If you spend time planning and laying out your drawing in advance, it can help to reduce these issues.

If the engineering sketch is good quality, you can use it to plan your CADD layout and create a drawing according to correct drafting standards. However, if the engineering sketch is rough and does not represent your plans for making a professional-looking drawing, then you may want to prepare a new sketch before using CADD. Your sketch can be as simple or detailed as necessary and might include dimensions drawn according to ASME or other related standards.

Another step you may want to consider is the development of a project outline. Like your sketch, an outline can be as general or as complete as you feel necessary. An outline, like the example of a basic solid model part development outline shown in Figure 7.3, can act as a setup plan and progress checklist. Planning with a sketch and an outline can save time in completing the project because you have a good idea of what to do before you start working and what to do during the drawing and design process.

Project: DF24-0004-07  
 File: C:/DF24 WING/FLAP SUPPORT/SHAFT  
 Date: 08-20-10  
 Scale: 2:1  
 Sheet: C

### Outline

1. Open or create a model project.
2. Open a part file template, and create a new part file.
3. Define work and sketch environment settings.
4. Project the origin onto the sketch plane.
5. Draft sketch geometry (initial base feature outline).
6. Add geometric constraints and dimensions.
7. EXTRUDE an initial feature from the sketch profile.
8. Draft sketch geometry on the base feature, and REVOLVE the sketch.
9. Add HOLE.
10. Place CHAMFER and FILLETS.
11. Resave.

© Cengage Learning 2012

FIGURE 7.3 A CADD project outline.

## DRAFTING GEOMETRY

Machine parts and other manufactured products are constructed of different geometric shapes ranging from squares and cylinders to complex irregular curves. **Geometric constructions** are methods that can be used to draw various geometric shapes or to perform drafting tasks related to the geometry of product representation and design. The proper use of geometric constructions requires a basic understanding of **plane geometry**. Plane geometry, in its most basic definition, is the geometry of two-dimensional (2-D) objects. The accuracy of CADD plays an important role when using geometric construction techniques to create a drawing. When computers are used in drafting, the task of creating most geometric construction-related drawings is often easy, although the theory behind the layout of geometric shapes and related constructions is important to confirm that the CADD system performs as expected.

### CHARACTERISTICS OF LINES

A **straight line segment** is a line of any given length, such as lines A–B shown in Figure 7.4.

A **curved line** can be in the form of an arc with a given center and radius or an irregular curve without a defined radius as shown in Figure 7.5.

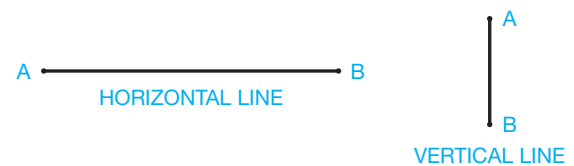


FIGURE 7.4 Horizontal and vertical lines.



FIGURE 7.5 Arc and irregular curve.

Two or more lines can intersect at a point as in Figure 7.6. The opposite angles of two intersecting lines are equal. For example,  $a = a$ ,  $b = b$  in Figure 7.6.

**Parallel lines** are lines equidistant throughout their length; if they were to extend indefinitely, they would never cross (see Figure 7.7).

**Perpendicular lines** intersect at a  $90^\circ$  angle as shown in Figure 7.8.

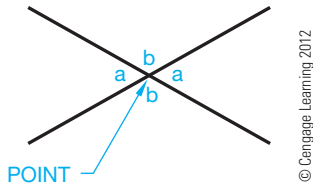


FIGURE 7.6 Intersecting lines.

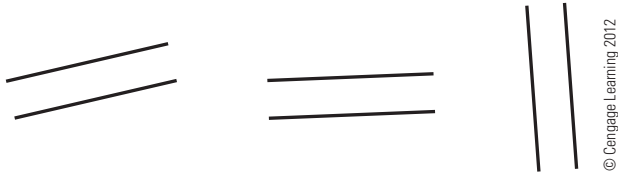


FIGURE 7.7 Parallel lines.

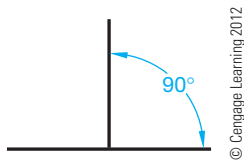


FIGURE 7.8 Perpendicular lines.

## GEOMETRIC SHAPES

The following information describes geometric shapes that are commonly used to construct 2-D and 3-D features on engineering drawings.

### Angles

Angles are formed by the intersection of two lines. Angles are sized in **degrees** ( $^{\circ}$ ). Components of a degree are **minutes** ( $'$ ) and **seconds** ( $''$ ). There are 60 minutes ( $'$ ) in one degree, and there are 60 seconds ( $''$ ) in 1 minute;  $1^{\circ} = 60'$ ,  $1' = 60''$ . Figure 7.9 shows the four basic types of angles. A **straight angle** equals  $180^{\circ}$ . A **right angle** equals  $90^{\circ}$ . An **acute angle** contains more

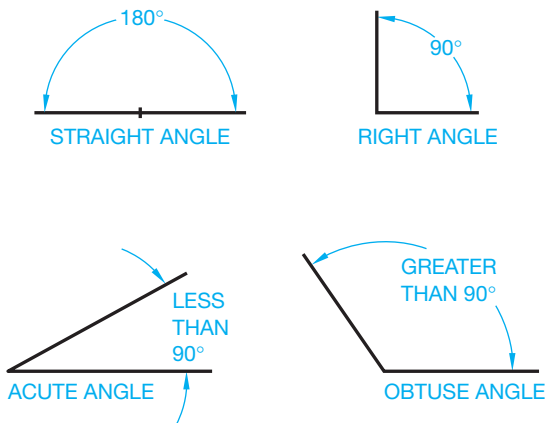


FIGURE 7.9 Types of angles.

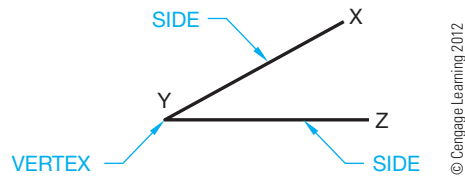


FIGURE 7.10 Parts of an angle.

than  $0^{\circ}$  but less than  $90^{\circ}$ . An **obtuse angle** contains more than  $90^{\circ}$  but less than  $180^{\circ}$ .

Figure 7.10 shows the parts of an angle. An angle is labeled by giving the letters defining the line ends and vertex, with the vertex always between the ends. An example is angle XYZ where Y is the vertex (see Figure 7.10).

### Triangles

A **triangle** is a geometric figure formed by three intersecting lines creating three angles. The sum of the interior angles of a triangle always equals  $180^{\circ}$ . Figure 7.11 shows the parts of a triangle. Triangles are labeled by lettering the vertex of each angle, such as ABC, or by labeling the sides abc as shown in Figure 7.12.

There are three kinds of triangles: acute, obtuse, and right as shown in Figure 7.13. Two special acute triangles are the **equilateral**, which has equal sides and equal angles, and the

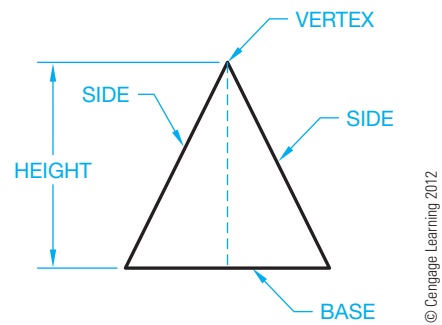


FIGURE 7.11 Parts of a triangle.

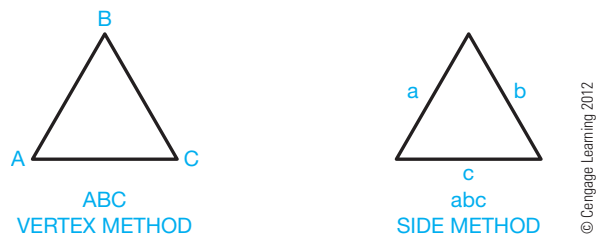
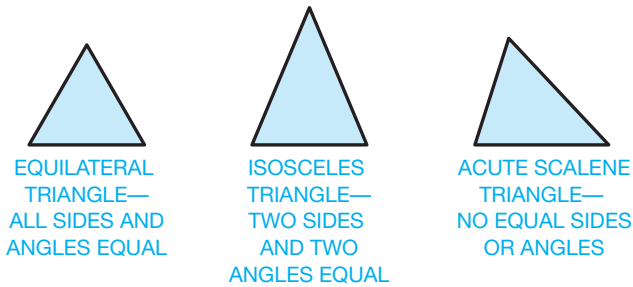
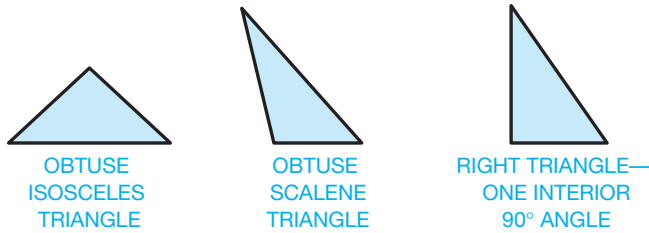


FIGURE 7.12 Labeling triangles.



ACUTE TRIANGLES (NO INTERIOR ANGLE IS GREATER THAN 90°)



OBTUSE TRIANGLES (ONE INTERIOR ANGLE GREATER THAN 90°)

FIGURE 7.13 Types of triangles. © Cengage Learning 2012

isosceles, which has two equal sides and two equal angles. An isosceles triangle can also be obtuse. In a scalene triangle, no sides or angles are equal.

### Right Triangles

Right triangles have certain unique geometric characteristics. Two internal angles equal 90° when added. The side opposite the 90° angle is called the **hypotenuse** as shown in Figure 7.14. A semicircle, or half-circle, is always formed when an arc is drawn through the vertices of a right triangle as shown in Figure 7.15.

### Quadrilaterals

Quadrilaterals are four-sided polygons that can have equal or unequal sides or interior angles. The sum of the interior angles is 360°. Quadrilaterals with parallel sides are called **parallelograms** (see Figure 7.16).

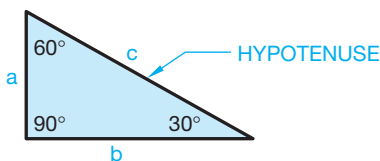


FIGURE 7.14 Right triangle.

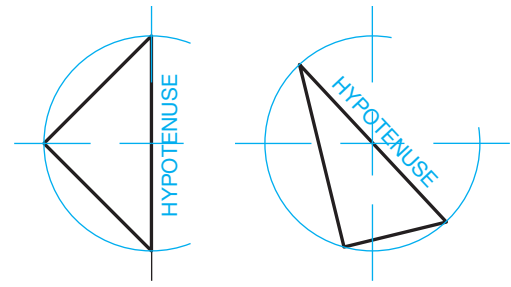


FIGURE 7.15 A semicircle is formed when an arc is drawn through the vertices of a right triangle.

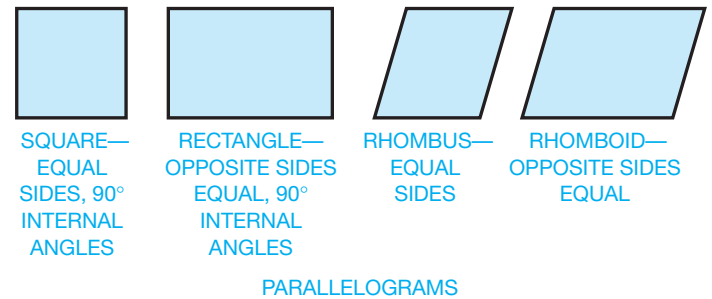


FIGURE 7.16 Quadrilaterals. © Cengage Learning 2012

### Regular Polygons

Some of the most commonly drawn geometric shapes are regular polygons. **Regular polygons** have equal sides and equal internal angles. **Polygons** are closed figures with at least three sides and any number of other sides. The relationship of a circle to a regular polygon is that a circle can be drawn to touch the corners of the polygon, referred to as **circumscribed**, or a circle can be drawn to touch the sides of the polygon, referred to as **inscribed**. The sides of a regular polygon are called the **flats** (see Figure 7.17). The relationship between a regular polygon and a circle is an

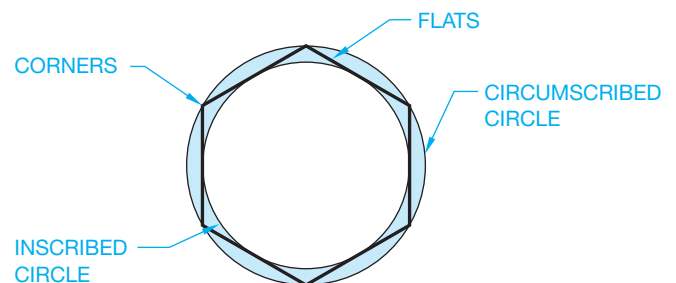
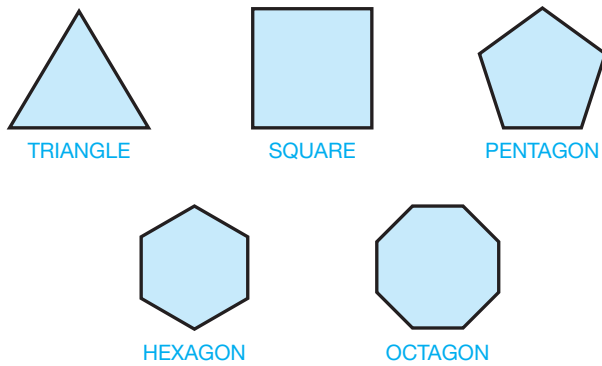


FIGURE 7.17 Regular polygons. © Cengage Learning 2012



© Cengage Learning 2012

FIGURE 7.18 Common regular polygons.

advantage in constructing regular polygons. Figure 7.18 shows some common regular polygons. The name of each regular polygon is derived from the number of sides. For example:

Name	Number of Sides
Triangle	3
Square	4
Pentagon	5
Hexagon	6
Octagon	8

### Regular Solids

Solid objects constructed of regular polygon surfaces are called **regular polyhedrons** (see Figure 7.19). A **polyhedron** is a solid formed by plane surfaces. The surfaces are referred to as **faces**.

### Prisms

A **prism** is a geometric solid object with ends that are the same size and of the same shaped polygons and sides that connect the same corresponding corners of the ends. Figure 7.20 shows a few common examples of prisms. A **right prism** has sides that meet  $90^\circ$  with the ends. An **oblique prism** has sides that are at an angle to the ends.

### Pyramid Prisms

A **pyramid prism** has a regular polygon-shaped base and sides that meet at one point called a **vertex** as shown in Figure 7.21. A geometric solid is **truncated** when a portion is removed and a plane surface is exposed. The **axis** is an imaginary line that connects the vertex to the midpoint of the base. The axis can also be referred to as an imaginary line around which parts are regularly arranged.

### Circles

A **circle** is a closed curve with all points along the curve at an equal distance from a point called the **center**. The circle has a total of  $360^\circ$ .

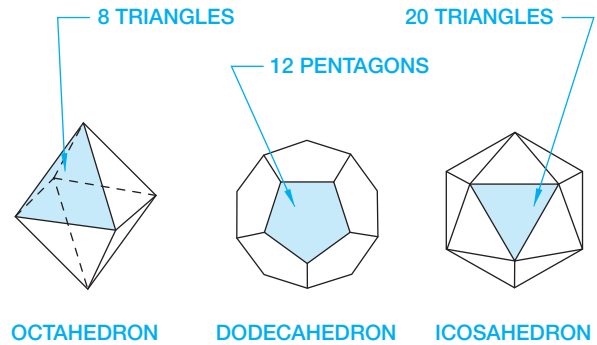
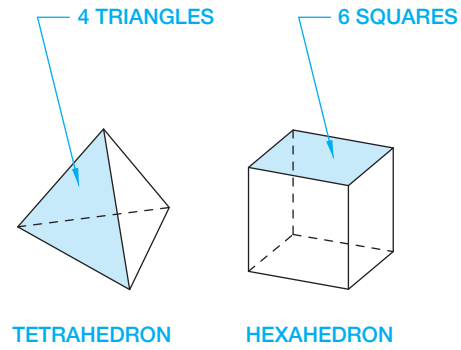


FIGURE 7.19 Regular solids.

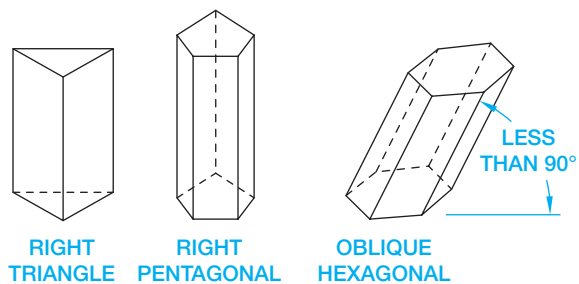
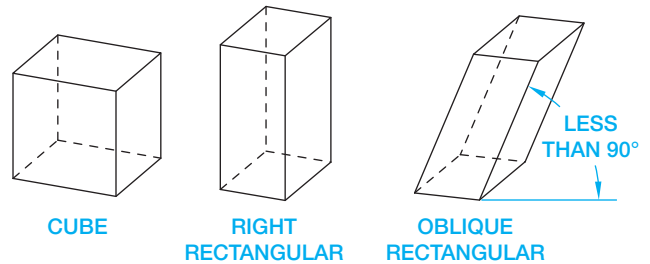


FIGURE 7.20 Common prisms.

The following describes the primary parts of a circle and two circle relationships. These parts and relationships are also shown in Figure 7.22:

- Center is located in the exact middle of the circle.
- Circumference is the distance around the circle—that is, the circle's edge.
- Diameter is the distance across the circle, from one side to another, through the center. Diameter is identified using the diameter symbol:  $\varnothing$ .

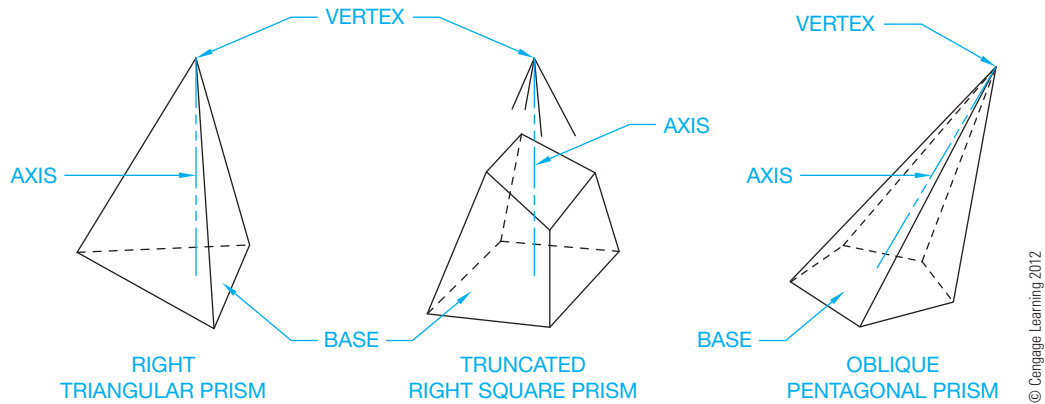


FIGURE 7.21 Common pyramid prisms.

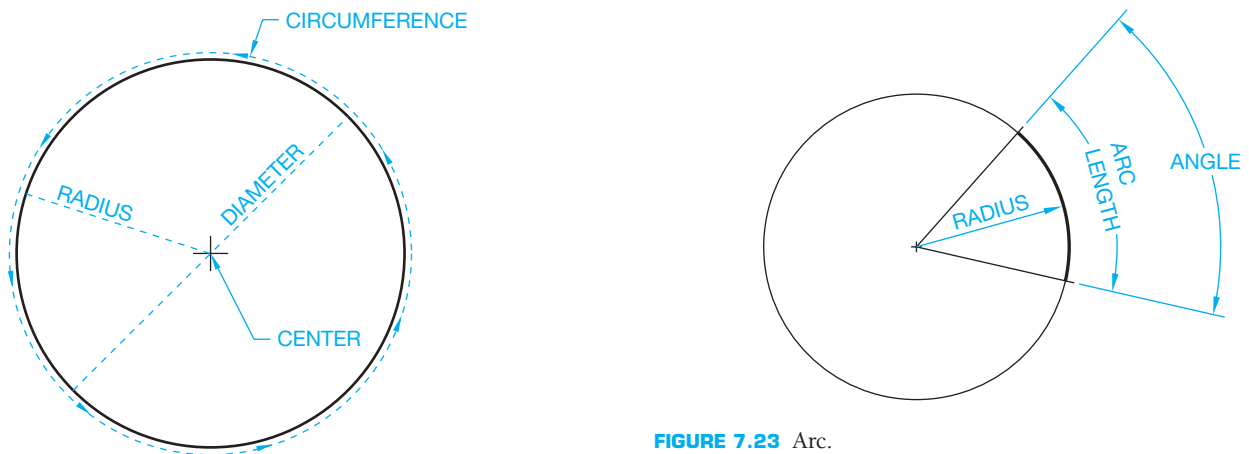


FIGURE 7.23 Arc.

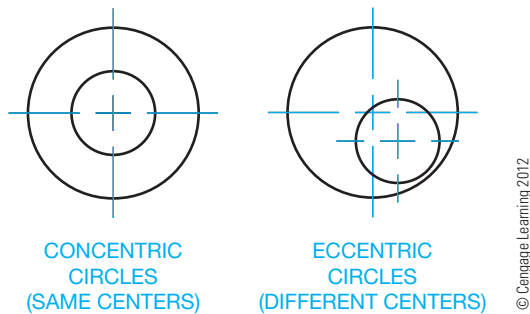


FIGURE 7.22 Parts of a circle and circle characteristics.

- Radius, identified using an uppercase R, is the distance from the center of the circle to the circumference. A circle's radius is always one-half of the diameter.
- Concentric circles share the same center.
- Eccentric circles have different centers.

### Arcs

An **arc** is part of the circumference of a circle. The arc can be identified by a radius, an angle, or a length. (See Figure 7.23.)

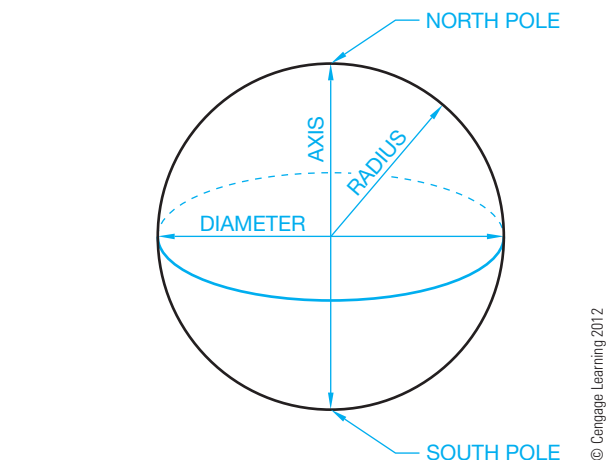
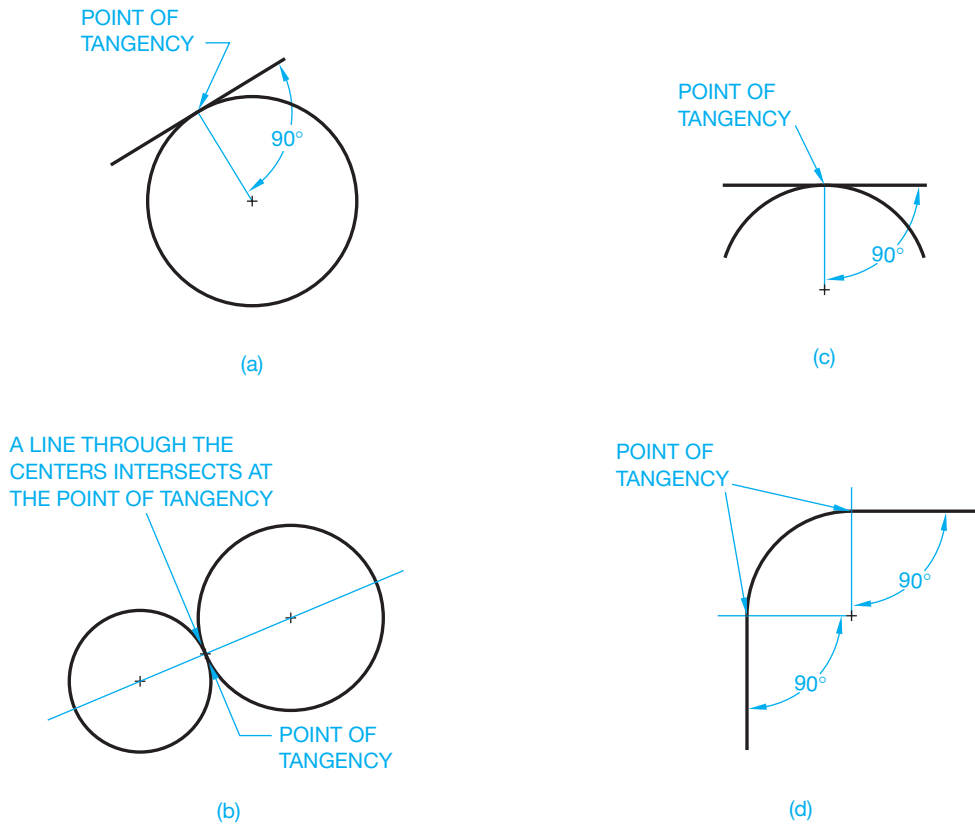


FIGURE 7.24 Sphere.

### Spheres

A **sphere** is three dimensional and the shape of a ball. Every point on the surface of a sphere is equidistant from the center. If you think of Earth as a sphere, the North and South poles are at the end of its axis as shown in Figure 7.24.



**FIGURE 7.25** Tangency applications. (a) A line tangent to a circle. The point of tangency is found by constructing a line from the center of the circle  $90^\circ$  to the tangent line. (b) Two tangent circles. A line drawn between the circles' centers establishes the point of tangency where the line intersects the circles. (c) A line tangent to an arc. The point of tangency is found by constructing a line from the center of the arc  $90^\circ$  to the tangent line. (d) A common application in an engineering drawing where an arc is drawn to form a radius  $90^\circ$  corner.

## Tangents

Straight or curved lines are **tangent** to a circle or arc when the line touches the circle or arc at only one point. If a line connects the center of the circle or arc to the point of tangency, the tangent line and the line from the center forms a  $90^\circ$  angle (see Figure 7.25). Figure 7.25a shows a line tangent to a circle. The point of tangency is found by constructing a line from the center of the circle  $90^\circ$  to the tangent line. Figure 7.25b shows two tangent circles. A line drawn between the circles' centers establishes the point of tangency where the line intersects the circles. Figure 7.25c shows a line tangent to an arc. The point of tangency is found by constructing a line from the center of the arc  $90^\circ$  to the tangent line. The drawing in Figure 7.25d is a common application in an engineering drawing where an arc is drawn to form a radius  $90^\circ$  corner.

## COMMON GEOMETRIC CONSTRUCTIONS

Understanding plane geometry and geometric construction is critical to developing drawings. Every design and drafting project requires you to recognize and properly create geometric

constructions. The process of applying geometric constructions is typically easy and accurate with CADD because of the many geometric construction tools available with most CADD systems. However, the more you know about geometric characteristics and shapes, the more effectively and efficiently you can solve design problems and prepare quality drawings.

The tools and commands available to complete geometric constructions differ with each CADD program, but the techniques are often similar. The geometric construction tools and techniques available with CADD can save a significant amount of time and help you generate very accurate drawings. However, if a geometric construction tool or command is not available for a specific application, you can always rely on the techniques identified in this chapter. Remember, a drawing consists of shapes and text, whether it was produced using manual drafting or CADD.

The following information provides examples of basic methods for using CADD to create the common geometric constructions previously defined in this chapter. Many other CADD tools and settings are available to accomplish the same tasks. Most CADD systems offer many options for constructing geometry and often several methods for producing a specific

geometric construction. For example, some programs provide an ARC command with multiple options for drawing arcs, and other systems include several individual ARC tools. The intent is to increase efficiency and flexibility while drawing, by allowing you to choose the appropriate method to complete a design and drafting task. Basic geometric construction tools such as LINE, CIRCLE, and ARC are common to most CADD software, although they often function slightly different, depending on the program and drawing requirement. This chapter focuses on generic geometric construction tools and techniques but also identifies command names specific to software such as AutoCAD. If you use CADD software other than AutoCAD, your program has tools that may be the same, similar, or different from the AutoCAD tools.

Geometric construction with CADD usually involves the process of establishing a point or location by using the cursor to pick an on-screen point, entering coordinates, or typing a value. To locate a point, such as the first and second end points of a line, or the center of a circle, you typically pick on screen or enter coordinates. Geometric constructions, such as defining a point of tangency, can require you to select objects. Some commands allow you to respond with a numerical value, such as defining the length of a line or the diameter of a circle. Depending on the CADD software or command, you may have the option to enter specific information before drawing the geometry, such as defining the diameter of a circle followed by placing the circle.

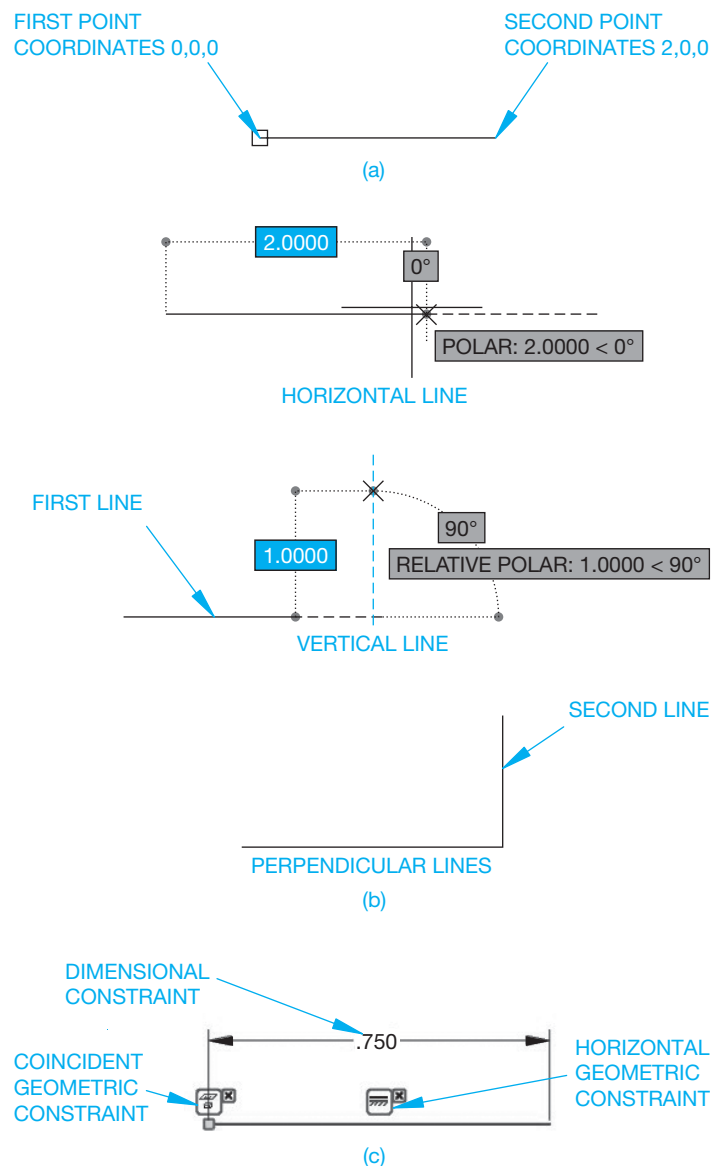
Most CADD software offers drawing aids or **constraints** that assist geometric construction. AutoCAD provides Object Snap and AutoTrack functions that allow you to apply common geometric constructions while you draw. For example, use a PERPENDICULAR object snap to draw a line perpendicular to an existing line; a CENTER object snap to reference the center of a circle, arc, ellipse, elliptical arc, or radial solid; and a TANGENT object snap to find the point of tangency between radial and linear objects. **Geometric constraints** allow you to assign specific geometric constructions and relationships to objects that are required to build a parametric drawing. Unlike drawing aids, such as AutoCAD Object Snap and AutoTrack, constraints control the size and shape of geometry. For example, a SYMMETRIC geometric constraint establishes symmetry between objects or points and a line, ellipse axis, or text boundary as the line of symmetry, depending on the software. You cannot break the symmetrical relationship without removing the SYMMETRIC constraint. A CONCENTRIC constraint constrains the center of a circle, arc, or ellipse, to another circle, arc, or ellipse. You cannot break the concentric relationship without removing the CONCENTRIC constraint.

## Drawing Lines

The basic approach to drawing a straight line segment is to access a command such as LINE, specify the first end point of the line, and then specify the second end point of the line. You often have the option to continue locating points to connect a series of line segments before exiting the LINE command. This allows you to establish angles and geometric shapes using a single

instance of the LINE command. When following a basic approach to constructing a line, such as using the basic **Cartesian coordinate system**, you are responsible for specifying end points that create the appropriate geometric construction. For example, to draw a horizontal line two units long, beginning at the **origin**, or point where  $X = 0$ ,  $Y = 0$ , and  $Z = 0$ , you specify coordinates 0,0,0 for the first end point followed by 2,0,0 for the second end point (see Figure 7.26a).

However, most CADD programs provide specific tools and options that assist drawing accurate lines, and forming common straight line segment geometric constructions. Figure 7.26b shows examples of drawing aids that allow you to draw an accurate two-unit horizontal line followed by a perpendicular, or



**FIGURE 7.26** Common methods for drawing lines. (a) Entering coordinates using the Cartesian coordinate system. (b) Using drawing aids to assist constructing horizontal and vertical lines of specific length. (c) A basic example of using constraints to define the size and location of a line. © Cengage Learning 2012

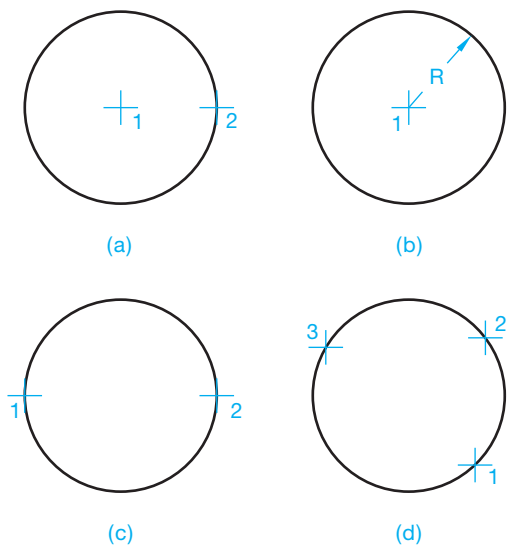


vertical, one-unit line with **coincident** end points. Coincident is a geometric construction that specifies two points sharing the same position. Another example is to assign constraints to lines. Figure 7.26c shows constructing a horizontal .750 unit line by adding a COINCIDENT geometric constraint to the line to locate the end point of the line at the origin, placing a HORIZONTAL geometric constraint on the line to specify the line as horizontal, and defining the length of the line using a **dimensional constraint**. Constraints are useful because they place limits on geometry to preserve design intent and help form geometric constructions.

### Drawing Circles

There are usually several different ways to draw a circle. Select the appropriate method to draw a circle based on the information that you know about the circle. For example, if you know the location of the center of the circle and the diameter of the circle, use an option that allows you to specify the center and diameter. Use a CIRCLE command and one of the following common options to draw a circle. Some CADD programs include variations of the following options:

- Select the center and a point on the circumference to establish the radius (see Figure 7.27a).
- Specify the center point and enter a radius value (see Figure 7.27b).
- Select the center and a point past the circumference to establish the diameter.
- Specify the center point and enter a diameter value.
- Choose two opposite points on the circumference to establish the diameter (see Figure 7.27c).
- Choose two opposite points on the circumference to establish the diameter (see Figure 7.27c).



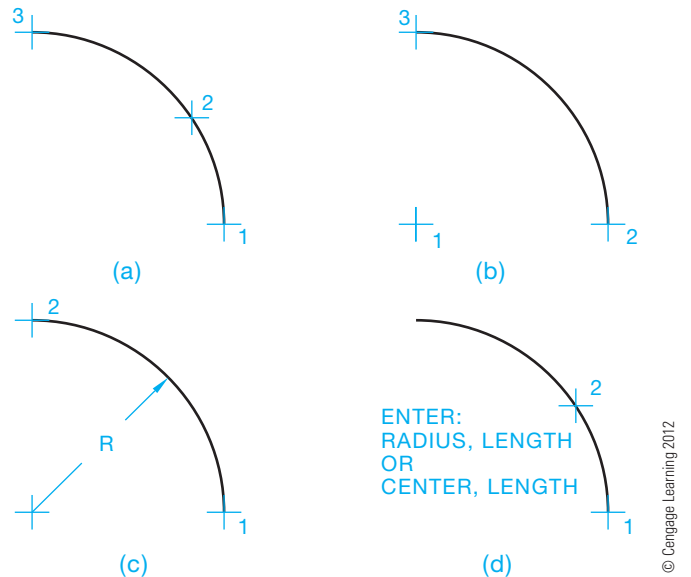
**FIGURE 7.27** Examples of options for drawing a circle. (a) Select the center and a point on the circumference. (b) Select the center and enter a value for the radius. (c) Select two points on the circumference. (d) Select three points on the circumference.

- Select three points on the circumference (see Figure 7.27d).
- Apply a method for constructing a circle tangent to objects, as described later in this chapter.

### Drawing Arcs

There are usually several different ways to draw an arc. Select the appropriate method to draw an arc based on the information that you know about the arc. For example, if you know the locations of the first and second end points of the arc and its radius, then use an option that allows you to specify the end points and radius. Use an ARC command and one of the following common options to draw an arc. Some CADD software offers several variations of the following options:

- Specify the start point, a point along the arc, and the end point (see Figure 7.28a).
- Select the center point, the start point, and the end point (see Figure 7.28b).
- Specify the start point and the end point and enter a radius value (see Figure 7.28c).
- Choose the start point and a point along the arc and enter the radius and length or chord length (see Figure 7.28d).
- Choose the start point and a point along the arc and enter the center and length or chord length (see Figure 7.28d).
- Select the start point, the center point, and an included angle.
- Select the start point, the end point, and a tangent direction.
- Apply a method for constructing an arc tangent to objects as described later in this chapter.



**FIGURE 7.28** Common methods for drawing arcs. Several variations of these options are often available. (a) Select three points on the arc. (b) Select the center point, start point, and end point. (c) Select the start point and the end point and enter a radius value. (d) Specify the start point and a point along the arc and enter a value for the radius and arc length, or specify the center point and arc length.

## Drawing Parallel Objects

**Parallel lines** are lines evenly spaced at all points along their length and do not intersect even when extended. Figure 7.29 shows an example of parallel lines. The space between parallel lines can be any distance. CADD software typically offers drawing aids or constraints that assist drawing parallel lines. Access a LINE or similar command to draw parallel lines using one of the following methods:

- Draw horizontal, vertical, or angle lines with a consistent equal space between lines. Common drawing aids for drawing parallel lines include PARALLEL object snap, grid, grid snap, orthogonal mode, and AutoTrack. Orthogonal refers to settings that force you to draw only horizontal or vertical lines.
- Draw a line and then use a command such as OFFSET to draw another line a given distance from the first line.
- Apply a PARALLEL geometric constraint to specify lines as parallel.

**Concentric circles** are parallel circles drawn from the same center. The distance between circles is equal as shown in Figure 7.30. Draw concentric circles using one of the following techniques:

- Draw one circle with a desired diameter and then draw another circle with a different diameter from the center of the first circle. Use an appropriate method, such as a CENTER object snap, to reference the center of an existing circle.
- Draw one circle and then use a command such as OFFSET to draw another circle a given distance from the first circle.



FIGURE 7.29 Parallel lines.

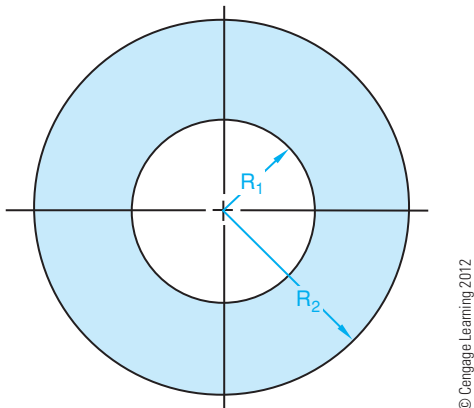


FIGURE 7.30 Concentric circles.

- Assign a CONCENTRIC geometric constraint to specify circles as concentric.

**Parallel or concentric arcs** share the same center and have an equal distance between arcs. Establish parallel arcs by adding the radius of arc 1 ( $R$ ) to the distance between the arcs ( $X$ ), as shown in Figure 7.31. Draw concentric arcs using one of the following techniques:

- Draw one arc with a desired radius and then draw another arc with a different radius from the center of the first arc. Use an appropriate method, such as a CENTER object snap, to reference the center of an existing arc.
- Draw one arc and then use a command such as OFFSET to draw another arc a given distance from the first arc.
- Assign a CONCENTRIC geometric constraint to specify arcs as concentric.

Parallel irregular curves that are not defined by a specific radius are drawn any given distance ( $R$ ) apart by using a command such as OFFSET set at the given distance (see Figure 7.32).

## Drawing Perpendicular Lines

**Perpendicular lines** intersect at  $90^\circ$ , which is referred to as a *right angle* as shown in Figure 7.33. CADD systems usually offer drawing aids or constraints that assist drawing perpendicular

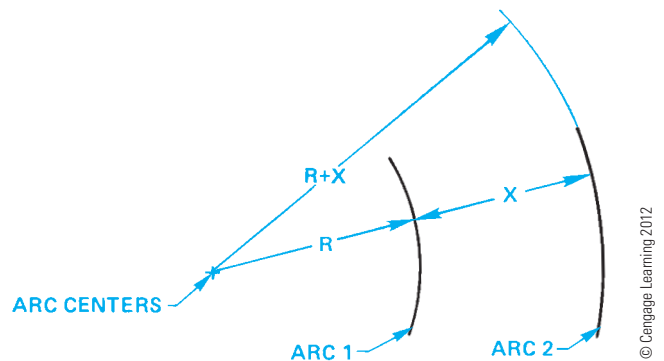


FIGURE 7.31 Parallel, or concentric, arcs.

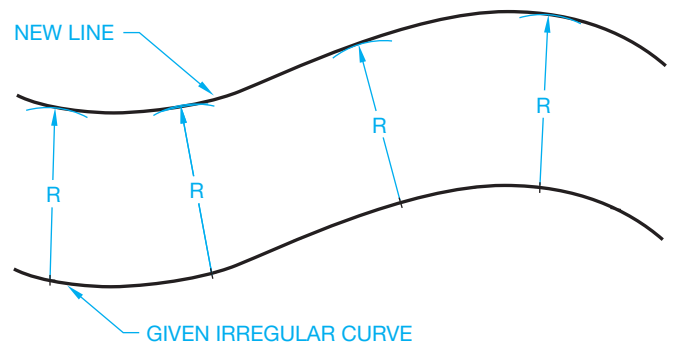


FIGURE 7.32 Constructing parallel irregular curves. © Cengage Learning 2012

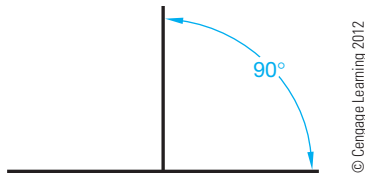


FIGURE 7.33 Perpendicular lines.

lines. Access a LINE or similar command to draw perpendicular lines using one of the following methods:

- Draw lines at a right angle. Common drawing aids for drawing perpendicular lines include PERPENDICULAR object snap, grid, grid snap, orthogonal mode, and AutoTrack.
- Apply a PERPENDICULAR geometric constraint to specify lines as perpendicular.

### Constructing a Perpendicular Bisector

The perpendicular bisector is a line that intersects another line or object at 90°, dividing the line or object into two equal parts. CADD systems often provide drawing aids or constraints that assist drawing perpendicular bisectors. Construct a perpendicular bisector using any of the following options:

- Draw a line segment such as A–B in Figure 7.34a. With end point A as a center, draw an arc with a radius R more than half the length of line A–B. With end point B as a center, draw an arc with a radius equal to the radius of the first arc (see Figure 7.34a). Draw a line between the intersections of both arcs, creating the perpendicular bisector as shown in Figure 7.34a.
- Draw a line segment such as line A–B in Figure 7.34b. Use PERPENDICULAR and MIDPOINT object snaps, and related drawing aids to construct a line perpendicular to and through the midpoint of A–B as shown in Figure 7.34b.
- Establish a COINCIDENT geometric constraint at the midpoints of two line segments (see Figure 7.34b).

### Bisecting an Angle

Use one of the following methods to divide any given angle into two equal angles:

- Draw the desired angle shown in Figure 7.35a. Draw an arc with any radius ( $R_1$ ) as shown in Step 1 in Figure 7.35a. At the points where arc  $R_1$  intersects the sides of the angle, draw two intersecting arcs of equal radius ( $R_2$ ) as shown in Step 2 in Figure 7.35a. Connect a straight line from the vertex of the angle to or through the point of intersection of the two arcs.

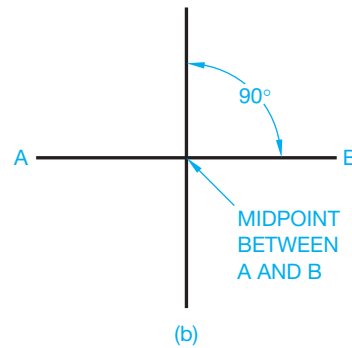
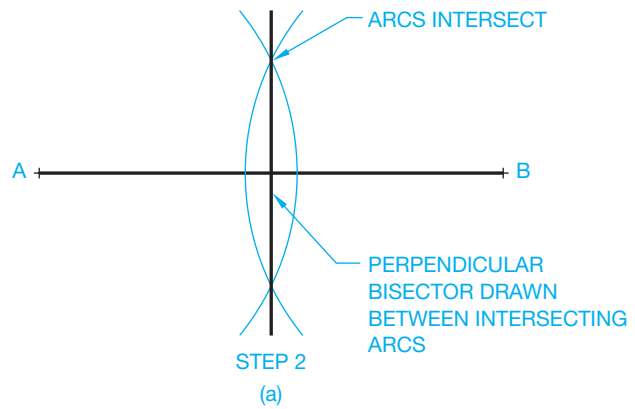
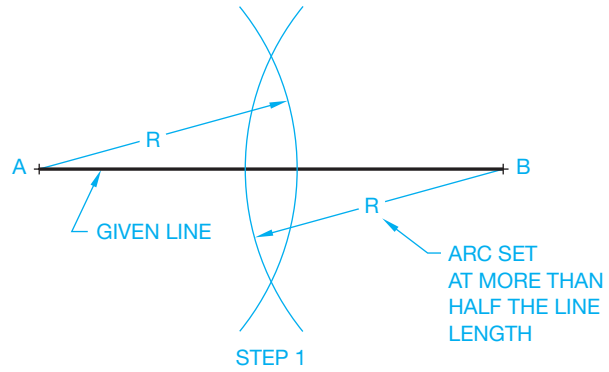
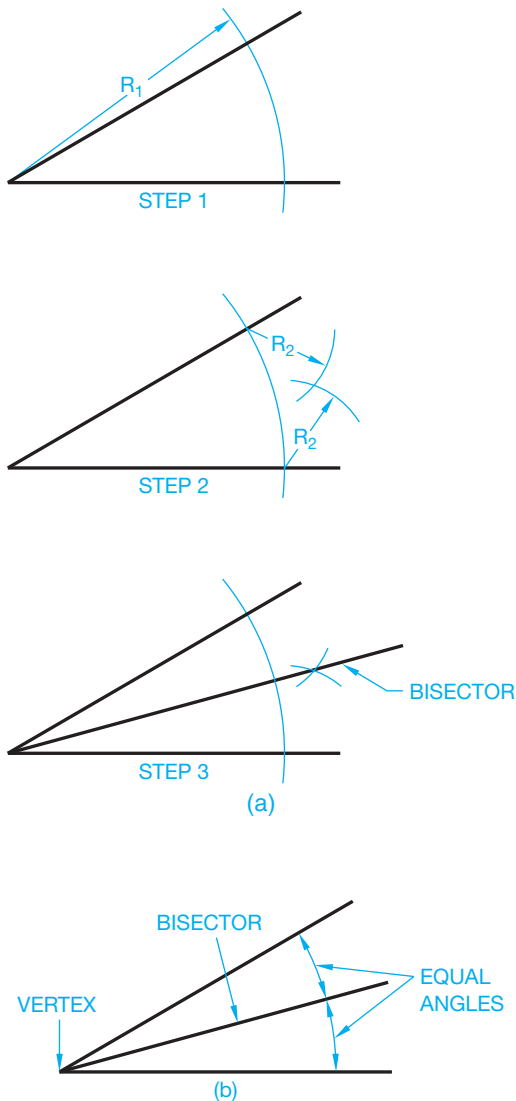


FIGURE 7.34 (a) Constructing a perpendicular bisector using arcs. (b) Constructing a perpendicular bisector using object snaps or geometric constraints.

- Apply specific bisecting tools such as the BISECT option of the AutoCAD XLINE command (see Figure 7.35b).
- Assign a SYMMETRIC geometric constraint to the sides of the angle and the bisector. Specify the bisector as the line of symmetry.
- Dimensionally constrain the angles between the bisector and each side using the same value (see Figure 7.35b). Alternatively, dimensionally constrain the total angle and apply a dimensional constraint that is one-half the total angle between the bisector and one side.

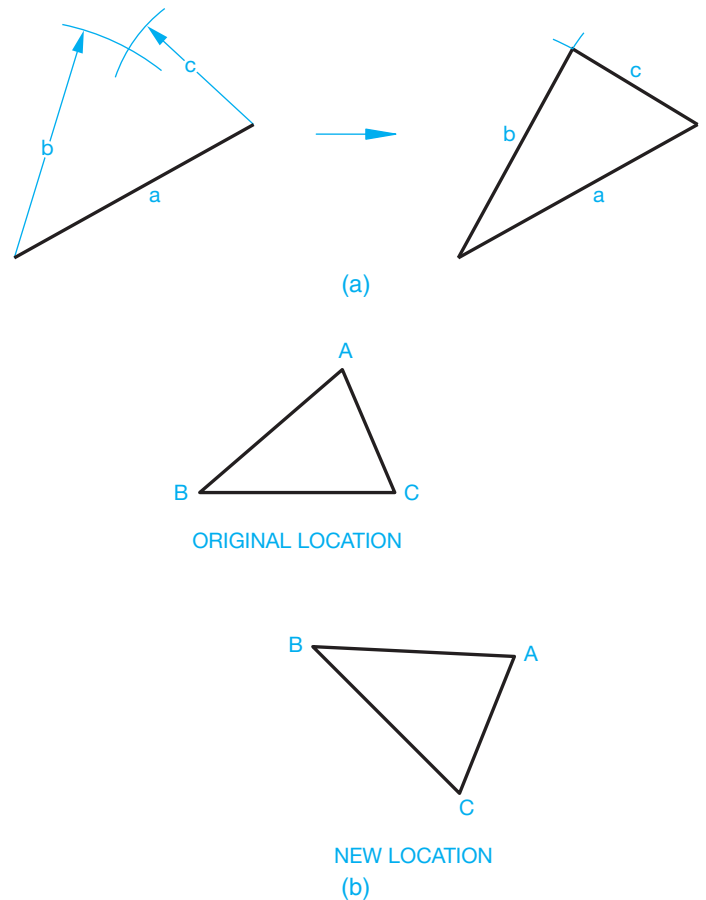


**FIGURE 7.35** (a) Bisecting an angle using arcs. (b) Bisect an angle using a bisector option or dimensional constraints.

### Transferring a Triangle to a New Location

Use one of the following techniques to transfer a given triangle to a new location as shown in Figure 7.36:

- Given any desired new location, draw one side of the triangle such as side  $a$  shown in Figure 7.36a. Draw an arc with a radius equal to the length of side  $b$ , with its center at one end of side  $a$  (see Figure 7.36a). Draw an arc with a radius equal to the length of side  $c$ , with its center at the other end of side  $a$  (see Figure 7.36a). Draw sides  $b$  and  $c$  from the ends of side  $a$  to the intersection of the two arcs as shown in Figure 7.36a.
- Use commands such as MOVE and ROTATE to move and rotate all sides of the triangle as needed. A command such as the AutoCAD ALIGN command allows you to move and



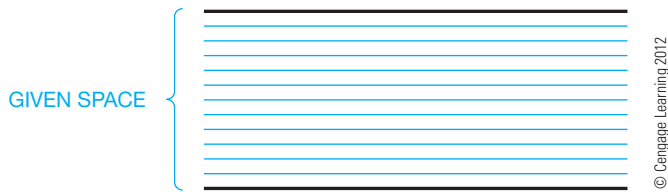
**FIGURE 7.36** Transferring a given triangle to a new location. (a) By constructing the sides. (b) Using commands such as MOVE, ROTATE, or ALIGN. © Cengage Learning 2012

rotate the triangle in one operation as shown in Figure 7.36b. You select two points such as  $B$  and  $C$ , on the triangle in the original location, and then specify the location of  $B$  and  $C$  in the new location as shown in Figure 7.36b.

- Create a parametric triangle and edit the parameters as needed to transfer the triangle to a new location.

### Dividing a Line into Equal Parts

You can use one several options to divide a line or another curve into equal parts. Some CADD software includes commands or options that considerably automate this process. For example, the AutoCAD DIVIDE command allows you to place usable reference point objects or symbols at equally spaced locations on a line, circle, arc, polyline, or spline. The software calculates the distance between marks based on the number of segments you specify. A similar command, MEASURE, allows you to place point objects or symbols a specified distance apart. In contrast to the DIVIDE tool, the length of each segment and total length of the object determine the number of segments. The DIVIDE and MEASURE commands do not break an object at specific lengths.



**FIGURE 7.37** Dividing a given space into equal parts.

## Dividing a Space into Equal Parts

A common requirement is to divide a given space into a number of equal sections. For example, divide the space shown in Figure 7.37 into 12 equal parts using one of the following methods:

- Draw a construction line between the left or right ends of the given lines. Then use a command such as `DIVIDE` and an increment value of 12 to place equally spaced marks along the construction line. The marks indicate the extents of 12 equal segments. Now draw lines from each mark parallel to the given lines.
- Use a measurement tool such as `DISTANCE` to measure the space to divide. Then use the CADD software calculator to calculate the measurement between each division. In this case, divide the total distance between the two lines by 12. Use the calculated measurement between each division to draw a series of offsets using a command such as `OFFSET`.
- Use a command such as `RECTANGULAR PATTERN` or `ARRAY` to draw the specified number of lines between the two given lines. Use the individual space calculation that you found in the previous example to specify the spacing between lines. Alternatively, you may have the option to enter the total spacing and allow the software to calculate the spacing between lines automatically.
- In some applications, you may be able to use a graphic pattern to fill a space. This is an option for the example in Figure 7.37, but you must select the appropriate pattern to create horizontal lines and specify the required scale and angle given pattern geometry, total space to fill, and number of increments.

## CONSTRUCTING POLYGONS

You can draw polygons using a basic `LINE` or similar command and standard geometric construction techniques. However, most CADD programs include specific tools that automate drawing polygons, especially regular polygons and rectangles.

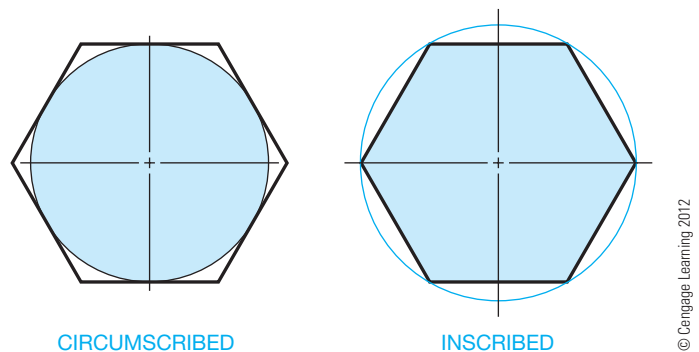
### Drawing Regular Polygons

A polygon is any closed plane geometric figure with three or more sides or angles. Pentagons, hexagons, and octagons are

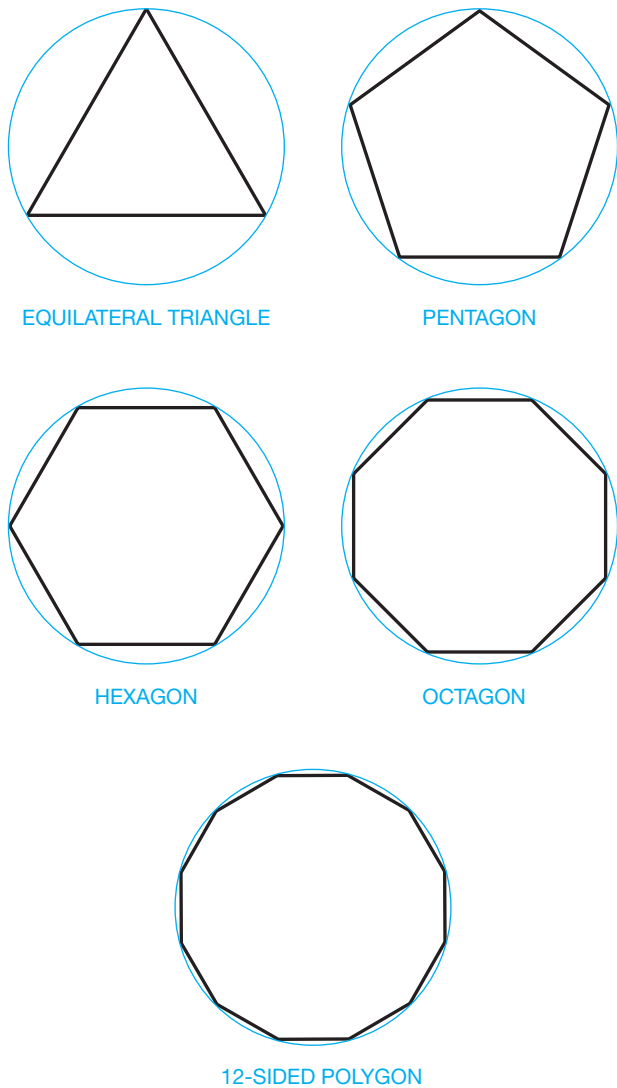
regular polygons. A regular polygon has equal sides and angles. A hexagon is a common polygon to draw for manufacturing applications such as hexagon head bolts and socket head screws. You can draw any regular polygon if you know the distance across the flats, or the distance across the corners, and the number of sides. When drawing a polygon given the distances across the flats, the polygon is circumscribed around the circle. When drawing a polygon given the distances across the corners, the polygon is inscribed in the circle (see Figure 7.38). The dimension across the flats is normally given when drawing a hexagon head machine screw.

Apply one of the following options to construct a regular polygon, such as those shown in Figure 7.39:

- Access a command such as `POLYGON`, specify the polygon as circumscribed or inscribed, enter the number sides, choose a location for the center, and specify the distance across the flats or corners as appropriate given the selected circumscribed or inscribed option.
- If you do not know the center of the polygon or the distance across the flats or corners, you may have the option to draw a regular polygon according to the known length of each side. Access a command such as `POLYGON`, choose the number of sides, and then specify the start and end points of one of the sides, or edges, of the polygon.
- Use constraints to define the size and location of any closed polygon with the desired number of sides. To create a regular polygon, assign `EQUAL` geometric constraints to each side or multiple equal angular dimensional constraints.
- Reference this information if your CADD program requires calculations other than the basic dimension across the flats or corners and the number of sides: There are  $360^\circ$  in a circle, so if you need to draw a 12-sided polygon, divide  $360^\circ$  by 12 ( $360 \div 12 = 30^\circ$ ) to determine the central angle of each side. Because there are  $30^\circ$  between each side of a 12-sided polygon, divide a circle with a diameter equal to the distance across the flats into equal  $30^\circ$  parts. Then connect the 12 radial lines with line segments that are tangent to each arc segment.



**FIGURE 7.38** Drawing regular polygons given the distance across the flats (circumscribed) or corners (inscribed).

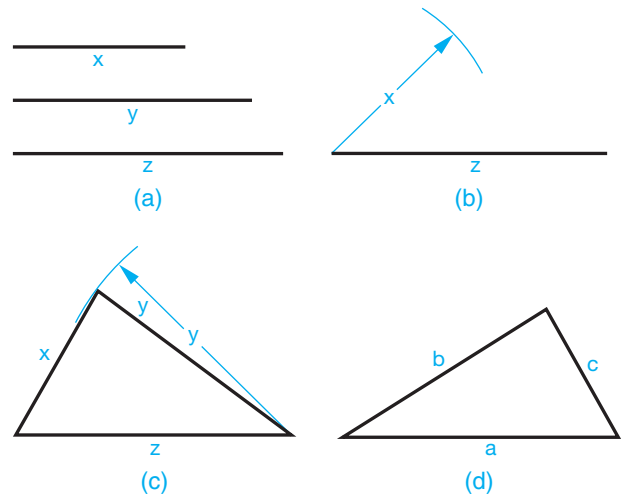


**FIGURE 7.39** Examples of regular polygons drawn by specifying the number of sides and the distance across the flats, corners, or the length of a side.

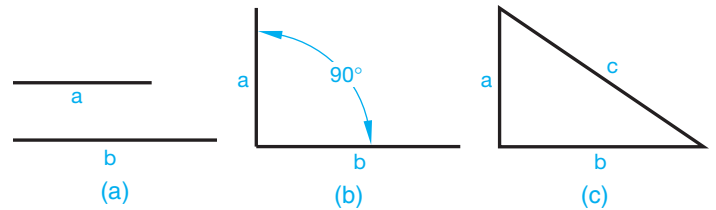
### Drawing a Triangle Given Three Sides

Use one of the following options to construct a triangle given three sides, as shown in Figure 7.40a:

- Apply the technique known as **triangulation** shown in Figure 7.40. Draw one of the given sides, such as side  $z$  in Figure 7.40b. From one end of line  $z$ , draw an arc equal in length to one of the other sides, such as  $x$  in Figure 7.40c. From the other end of line  $z$ , draw an arc with a radius equal to the remaining line,  $y$ , intersecting the previous arc. Where the two arcs cross, draw lines to the ends of the base line as in Figure 7.40d to complete the triangle.
- Access a command such as POLYGON and specify the number of sides as three.



**FIGURE 7.40** Constructing a triangle given three sides.



**FIGURE 7.41** Constructing a right triangle given two sides. © Cengage Learning 2012

- Use constraints to define the size and location of any three-sided closed polygon. If you know the length of each side, dimensionally constrain each side to construct the triangle.

### Constructing a Right Triangle Given Two Sides

Use one of the following options to construct a triangle when the lengths of the two sides next to the  $90^\circ$  angle are given, as shown in Figure 7.41a.

- Draw line  $a$  perpendicular to line  $b$  (see Figure 7.41b). Then connect a line from the end of line  $a$  to the end of line  $b$  to establish the right triangle (see Figure 7.41c). Common drawing aids for constructing perpendicular lines include PERPENDICULAR object snap, grid, grid snap, orthogonal mode, and AutoTrack. Use known coordinates or drawing aids such as ENDPOINT object snap to connect the hypotenuse.
- Use constraints to define the size and location of any three-sided closed polygon. Use a PERPENDICULAR geometric constraint to specify the sides adjacent to the  $90^\circ$  angle as perpendicular. Use dimensional constraints to size the sides adjacent to the  $90^\circ$  angle to match the given information.

### Constructing a Right Triangle Given One Side and the Hypotenuse

Follow one of these methods to draw a right triangle given the length of the hypotenuse and one side, as shown in Figure 7.42a.

- Draw line *c* and establish its midpoint. You can use the previously described perpendicular bisector method to find the midpoint, or you can use a drawing aid such as a MIDPOINT object snap (see Figure 7.42b). From the midpoint of line *c*, draw a 180° arc with the center at the midpoint of side *c* and the radius at the end of side *c* (see Figure 7.42c). From one end of side *c*, draw an arc with a radius equal to given side *a* (see Figure 7.42d). From the other end of line *c*, draw an arc intersecting the previous arc as shown in Figure 7.42e. From the intersection of the two arcs, draw two lines connecting the ends of line *c* to complete the required right triangle (see Figure 7.42e). Use drawing aids as previously described to ease this process.
- Use constraints to define the size and location of any three-sided closed polygon. Use a PERPENDICULAR geometric constraint to specify the sides adjacent to the 90° angle as perpendicular. Use dimensional constraints to size the known side and hypotenuse.

### Constructing a Square or Rectangle

A square has four equal sides and four 90° angles. Square-head bolts or square nuts are sometimes drawn with manufactured parts. You can use one of several methods to draw

*c* (HYPOTENUSE)

*a* (SIDE)

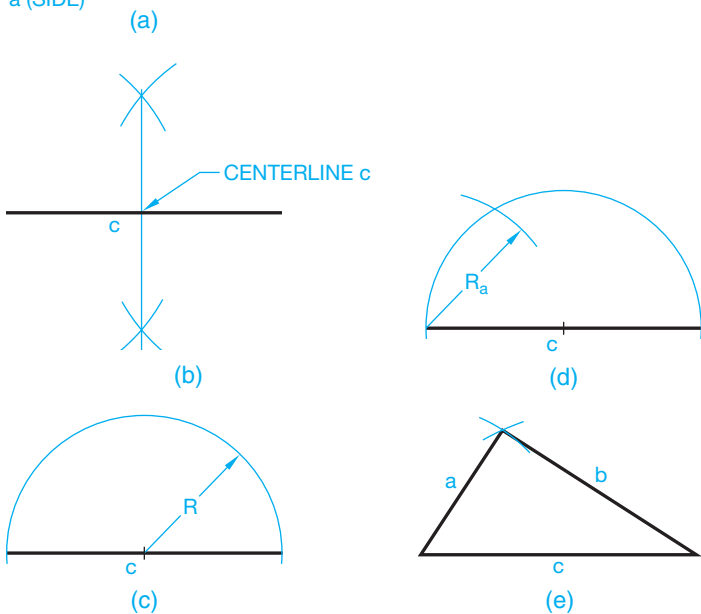


FIGURE 7.42 Constructing a right triangle given a side and hypotenuse. © Cengage Learning 2012

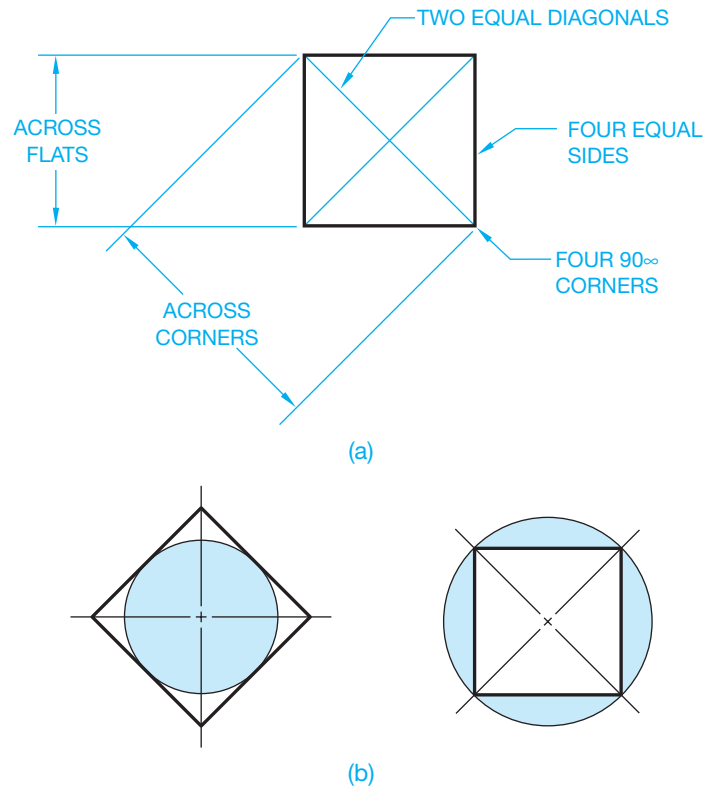


FIGURE 7.43 (a) Elements of a square. (b) A square circumscribed and inscribed with a circle. © Cengage Learning 2012

a square, each of which relates to the characteristics of the square shown in Figure 7.43. Draw a square using any of these options:

- Use a command such as LINE to construct the square using the information shown in Figure 7.43. You can also apply this technique to draw a **rectangle**. A rectangle has four 90° angles and sides creating a different length and width. Common drawing aids for constructing squares and rectangles include PERPENDICULAR, PARALLEL, and END-POINT object snap, grid, grid snap, orthogonal mode, direct distance entry, and AutoTrack.
- Access a command such as POLYGON and specify the number of sides as four (see Figure 7.41).
- Use a command such as RECTANGLE to pick one corner of the square and then pick the other corner given the length of a diagonal or known coordinates. You can also apply this technique to draw a rectangle. Multiple options or variations of the RECTANGLE tool may be available, depending on the program. A common example allows you to specify the length of a side instead of the diagonal. Choose the appropriate method to draw a square or rectangle according to the information that you know about the object.

- Use constraints to define the size and location of any four-sided closed polygon. Assign perpendicular or a combination of perpendicular and parallel geometric constraints to construct the basic shape. To develop a square, use equal geometric constraints and a single dimensional constraint. To create a rectangle, use a dimensional constraint to define the length and another to specify the width. If you know the length of each side, dimensionally constrain each side to construct the triangle.

## CONSTRUCTING TANGENCIES

Straight or curved lines are tangent to a circle or arc when the line touches the circle or arc at only one point. If a line connects the center of the circle or arc to the point of tangency, the tangent line and the line from the center form a 90° angle. Lines and arcs drawn tangent to circles and arcs are common geometric constructions used in engineering drafting.

### Drawing Tangent Arcs

A **fillet** and a **round** are common tangent arc applications. A fillet is an arc formed at the interior intersection between two 90° inside surfaces. A round is an arc formed at the interior intersection between two 90° outside surfaces. Use one of the following methods to draw an arc tangent to existing objects:

- Draw two intersecting or nonintersecting perpendicular lines. Then find the center of the arc at a distance equal to the arc radius from each line and draw an arc from the center using the desired radius. The arc is tangent to the two lines as shown in Figure 7.44. Use a command such as TRIM to clean up unwanted overruns if necessary.
- Use a command such as FILLET to draw a fillet, round, or an arc between two lines. A FILLET or similar command requires that you specify the arc radius and then select the two lines to draw an arc tangent to the lines (see Figure 7.44). A FILLET command may also allow you to construct a full radius, such as the arcs found on a slot. You may have the option to select parallel lines to create a full radius without knowing or specifying the radius.
- Apply a TANGENT geometric constraint to specify an arc tangent to a line, circle, arc, or ellipse.

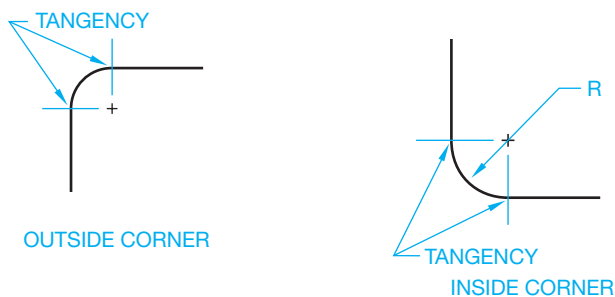


FIGURE 7.44 Corner tangencies.

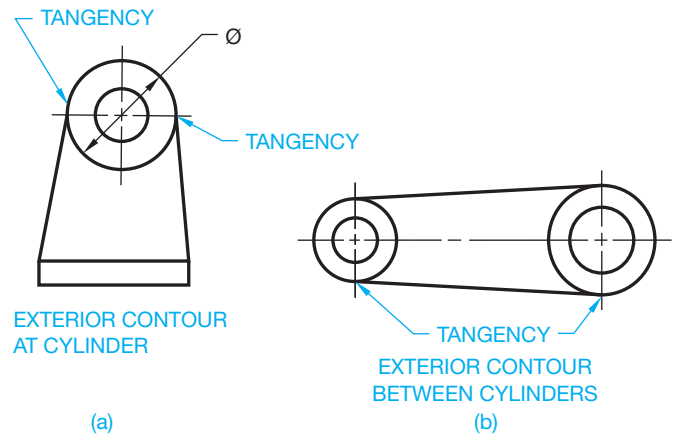


FIGURE 7.45 (a) Lines tangent to a circle. (b) Lines tangent to two circles.

### Drawing a Line Tangent to a Given Circle

Access a LINE or similar command and apply one of the following options to draw a line tangent to a given circle or arc:

- Start the line at a known point, such as the exterior contour of the cylinder shown in Figure 7.45a. Then use a drawing aid such as a TANGENT object snap to pick the point of tangency on the circle to complete the line at that point.
- Use a TANGENT object snap to specify the first end point at the point of tangency on a circle. You can then end the line at a known point or use another tangency construction to draw the line tangent to two circles as shown in the exterior contour between cylinders shown in Figure 7.45b.
- Assign a TANGENT geometric constraint to specify a line tangent a circle.

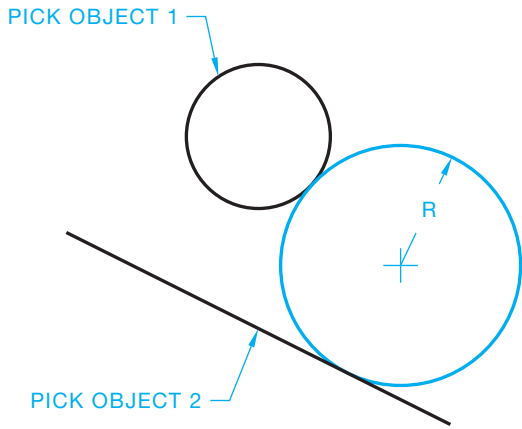
### Drawing a Circle Tangent to Existing Objects

Some CADD systems provide additional CIRCLE commands or options that automate the process of drawing a circle tangent to existing objects, such as lines, circles, arcs, and ellipses. Figure 7.46 shows an example of using a CIRCLE command to draw a circle tangent to a line and circle and according to a specified radius. You may also have the option to draw a circle tangent to three existing objects without knowing the radius. TANGENT geometric constraints can provide the same effect.

### Tangency Design and Drafting Applications

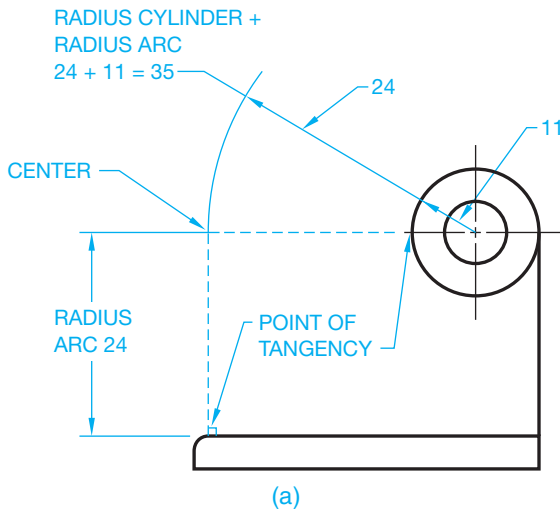
Many design and drafting applications contain tangencies. When drawing arcs tangent to other arcs or circles, remember that the distance from the point of tangency to the center of the tangent arc is equal to the radius of the tangent arc. The following information describes a variety of design and drafting tangency applications. Each application provides instruction



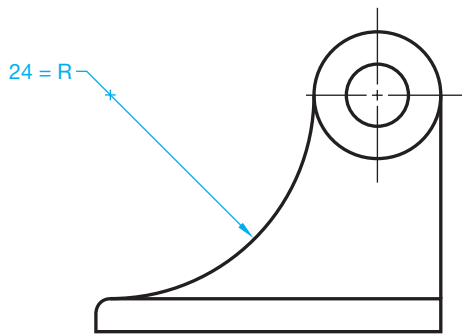


© Cengage Learning 2012

FIGURE 7.46 A circle tangent to a circle and a line.



(a)



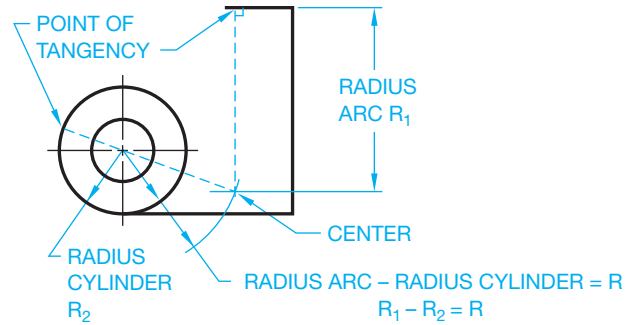
(b)

FIGURE 7.47 A tangency design and drafting application for a machine part. (a) A method for constructing an arc tangent to a given line and circle. (b) The final drawing view.

for drafting the geometry using a basic 2-D CADD program followed by more advanced methods that can be used to solve any of the tangency problems.

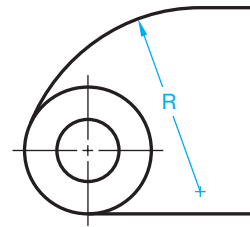
### Machine Part Examples

Given the initial geometry of the machine part shown in Figure 7.47a, draw an arc with a 24 mm radius to the



STEP 1

(a)



STEP 2

(b)

FIGURE 7.48 A tangency design and drafting application for a machine part. (a) A method for constructing an external arc tangent to a line and cylinder. (b) The final drawing view.

cylinder and base. Draw a line parallel to the base at a distance equal to the radius of the arc: 24 mm. Then draw an arc that intersects the line. The arc radius is equal to the given arc plus the radius of the cylinder ( $24 + 11 = 35$  mm) (see Figure 7.47a). Draw the required radius from the established center point (see Figure 7.47b).

Given the initial geometry of the machine part in Figure 7.48, draw an external arc tangent to a given circle and line as shown in Figure 7.48b. In this example, the radius of the cylinder (circle) is subtracted from the arc radius to get the center point. First, draw a line parallel to the top line at a distance equal to the radius of the  $R_1$  arc. Then draw an arc that intersects the line. The arc radius is equal to the given arc minus the radius of the cylinder ( $R_1 - R_2 = R$ ) (see Figure 7.48a). Draw the required radius from the established center point (see Figure 7.48b).

The examples in Figures 7.49 through 7.51 are situations that commonly occur on machine parts, where an arc can be tangent to given cylindrical or arc shapes. Keep in mind that the methods used to draw the tangents are the same as just described. The key is that the center of the required arc is always placed at a distance equal to its radius from the points of tangencies. To achieve this, you either add or subtract the given radius and the required radius, depending on the situation. When possible, use a template to draw circles and arcs.

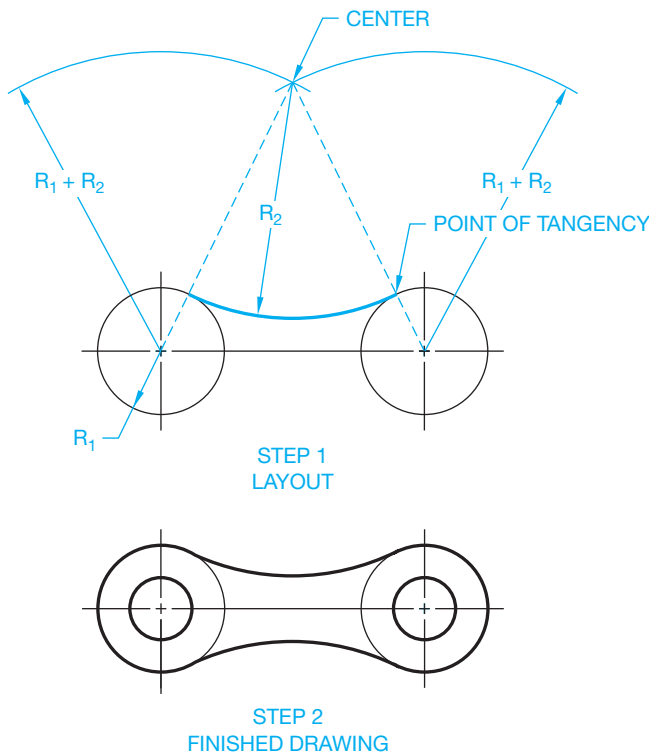


FIGURE 7.49 Constructing a chain link. © Cengage Learning 2012

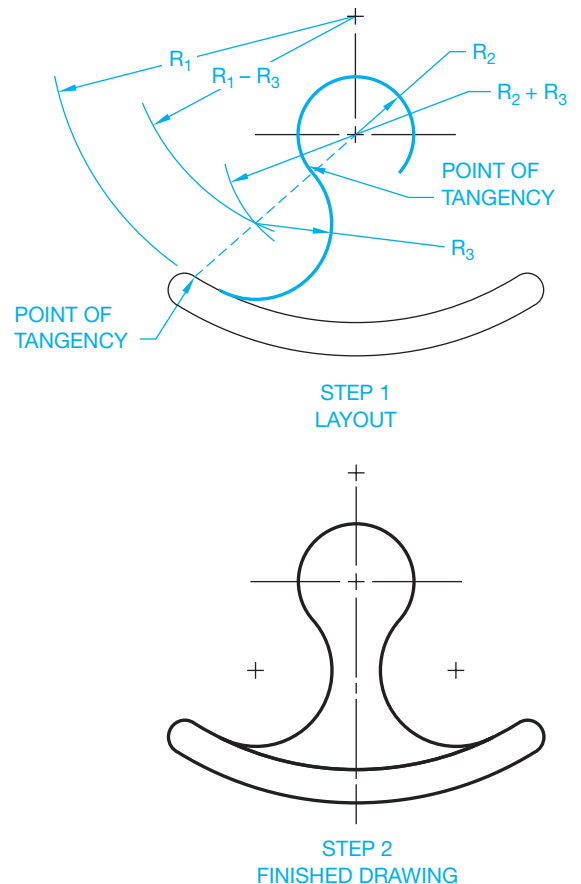


FIGURE 7.51 Constructing a hammer head.

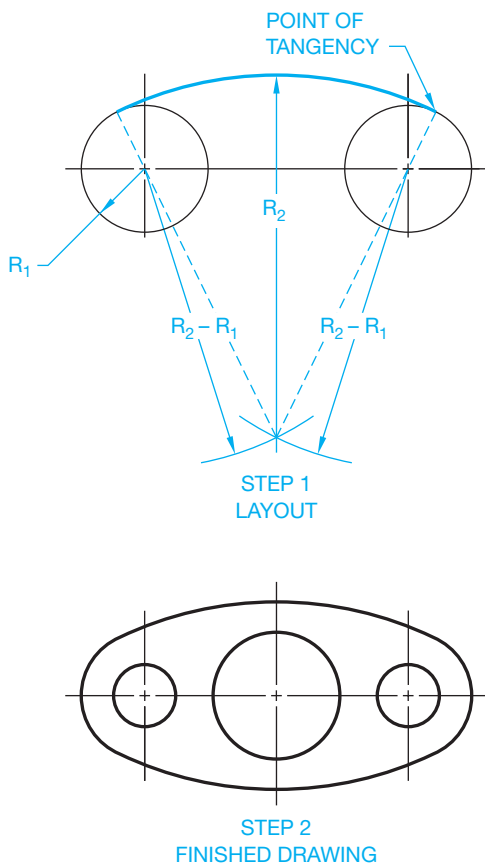


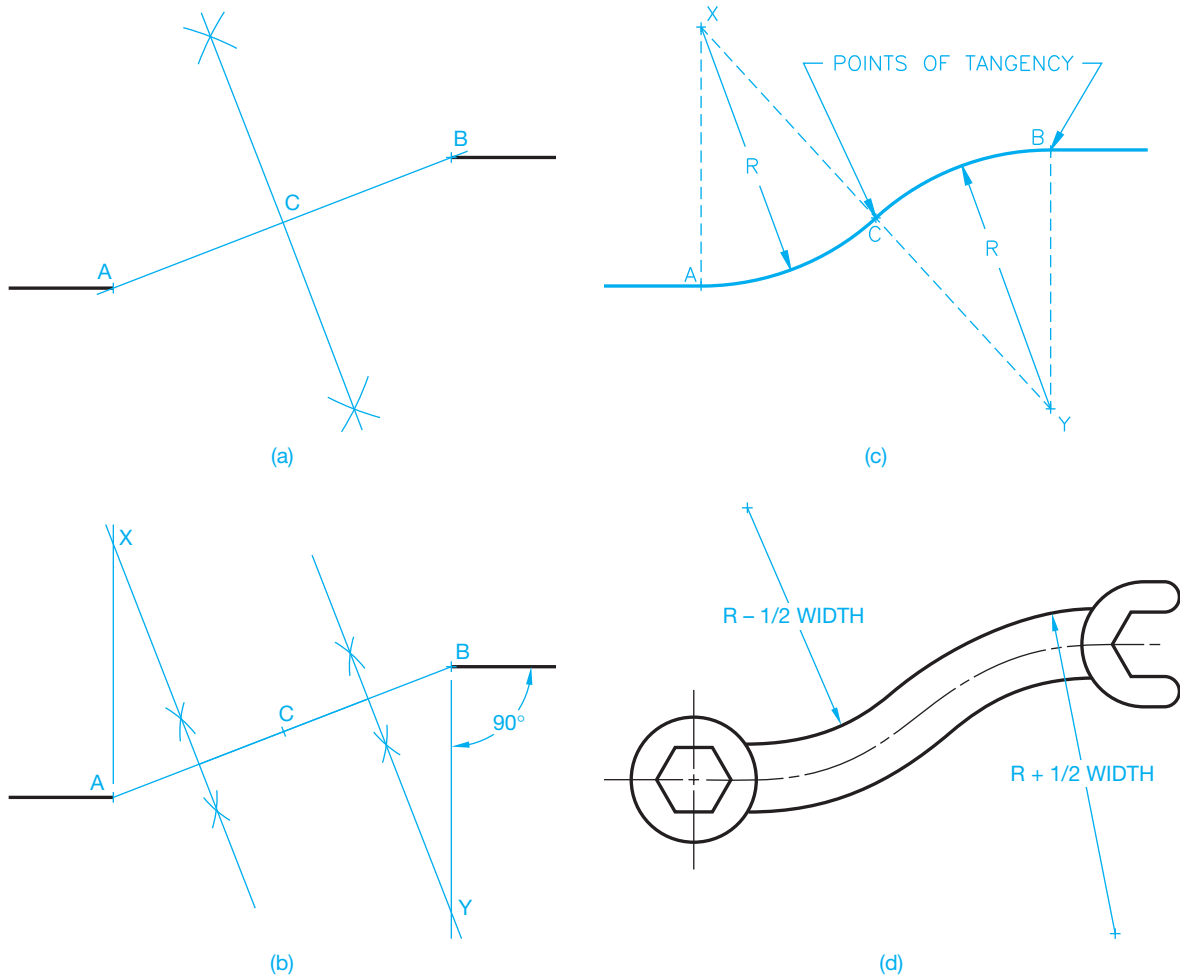
FIGURE 7.50 Constructing a gasket.

### Drawing an Ogee Curve

An S curve, commonly called an **ogee curve**, occurs in situations where a smooth contour is needed between two offset features as shown in Figure 7.52d. To draw an S curve with equal radii given the offset points A and B in Figure 7.52a, draw a line between points A and B and find midpoint C. Then draw the perpendicular bisector of lines AC and CB as shown in Figure 7.52b. From point A, draw a line perpendicular to the lower line that intersects the AC bisector at X. From point B, draw a line perpendicular to the upper line that intersects the CB bisector at Y (see Figure 7.52c). With X and Y as the centers, draw a radius from A to C and a radius from B to C as shown in Figure 7.52c. If the S-curve line, AB, represents the centerline of the part, then develop the width of the part parallel to the centerline using concentric arcs to complete the drawing (see Figure 7.52d).

When an S curve has unequal radii, the procedure is similar to the previous example, except the dimension from A to C and C to B establishes the desired point of tangency between the two arcs.

The methods given to construct tangencies in Figures 7.47 through 7.52 provide instruction for drafting geometry using a basic 2-D CADD program. You can use any of the following,



**FIGURE 7.52** Constructing an ogee curve handle wrench. (a) Bisecting the line between points A and B. (b) Bisecting the lines between points A and C, and C and B. (c) Constructing the ogee curve centerline. (d) The finished wrench with ogee curves.

© Cengage Learning 2012

more advanced methods to solve the tangency problems shown in Figures 7.47 through 7.52:

- Establish the known features such as circle diameters and locations. Use any command to accomplish the desired construction, such as the ARC command for drawing arcs. Use the desired design radius for arc construction. If you know the arc center points, draw the arc from the center point and use tangency object snaps to start the arc at the point of tangency on the first object and end the arc at point of tangency on the next object.
- When drawing an arc tangent to other circles or arcs and the center point for the desired arc is unknown, determine the points of tangency first. In this case, the points where the arc is tangent to two circles is found by locating both ends of the arc. Until both ends of the arc are identified, the object snap specification is for a **deferred tangency**. A deferred tangency is a construction in which calculation of the first point of tangency is delayed until both points of tangency are selected. When both points of tangency are selected, the tangencies are calculated

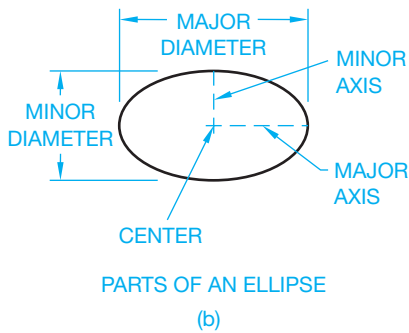
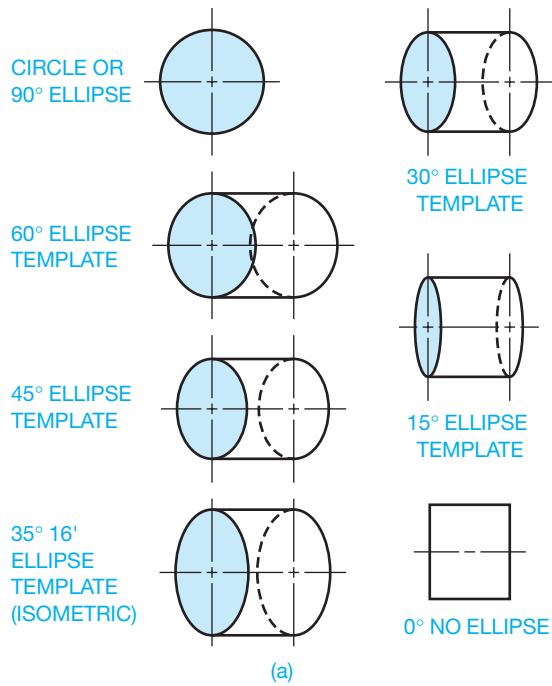
and the arc is drawn based on the radius you enter in the ARC command.

- Use COINCIDENT geometric constraints to locate the end points of arcs on existing objects and TANGENT geometric constraints to construct tangent relationships. Use dimensional constraints to define radii.

## CONSTRUCTING AN ELLIPSE

An **ellipse** is observed when a circle is viewed at an angle. Figure 7.53a shows the angular relationship of an ellipse to a circle. Figure 7.53b shows the parts of an ellipse. If a surface with a through hole is inclined 45°, the representation is a 45° ellipse. Access an ELLIPSE command and use one of the following common options to draw an ellipse:

- Locate the center and one end point for each of the two axes (see Figure 7.48b).
- Draw either the major axis or the minor axis and then enter a distance from the ellipse center to the end point of the other axis.



© Cengage Learning 2012

**FIGURE 7.53** (a) Ellipses are established by their relationship to a circle turned at various angles. (b) The parts of an ellipse.

- Draw the major axis and then use a ROTATION or similar option and enter the desired ellipse rotation angle to complete the ellipse. Figure 7.48a shows sample ellipse rotation angles.
- Assign dimensional constraints to define the size of the major and minor axes.

### Drawing an Elliptical Arc

An elliptical arc is any portion of an ellipse. For example, an elliptical arc can be one-quarter, one-half, or three-quarters of a full ellipse. Access an ELLIPSE, ELLIPSE ARC, or similar command with an ELLIPTICAL ARC or ARC option and construct an elliptical arc. The process for drawing an elliptical arc is usually similar to drawing an ellipse but with the added steps of specifying the start and end points of the elliptical arc.



### Common Manual Geometric Constructions

For information and instructions for using manual drafting techniques to create geometric constructions, go to the Student CD, select **Supplemental Material, Chapter 7**, and then **Common Manual Geometric Constructions**.

Even if you use CADD for your drafting applications, review of this CD content can provide you with methods for use when preparing sketches or detailed examples of creating geometric constructions that can help with difficult CADD applications. You can also use manual geometric construction methods with a basic CADD program that has limited construction tools and options.

## PROFESSIONAL PERSPECTIVE

Geometry and geometric construction applications shown and described in this chapter are found in nearly every engineering drafting assignment. Some geometric constructions are as simple as a radius corner while others are very complex. As a professional drafter, you should be able to quickly identify the type of geometric construction involved in the problem and solve it with one of the techniques you have learned, or you may need to combine a variety of applications.

Special attention to accuracy and technique are necessary when you solve these problems. You should always refer to the principles and techniques found in this chapter to ensure that your CADD application has performed the task correctly. Some of the previously very time-consuming constructions, such as dividing a space into equal parts, drawing a pentagon, or constructing an ogee curve are extremely fast and almost perfectly accurate when using CADD.

## INTERIOR ANGLES OF REGULAR POLYGONS

For a regular polygon with  $n$  sides, the formula for calculating interior angles is

$$\theta = (n - 2)/n \ 180^\circ$$

See the interior angle  $\theta$  in Figure 7.54.

The Greek letter **theta** ( $\theta$ ) is commonly used in geometry to stand for the measurement of an angle. As an example of using this formula, the interior angle of the hexagon in Figure 7.54 is

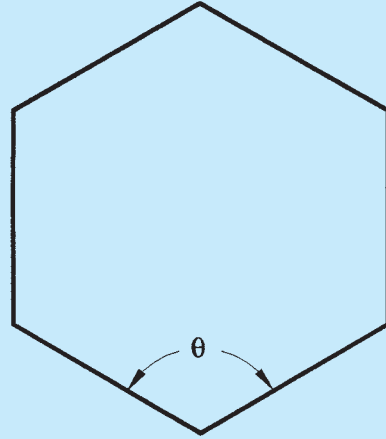
$$\theta = (6 - 2)/6 \ 180^\circ = (4)/6 \ 180^\circ = 120^\circ$$



**NOTE:** In algebra, the precedence is *always*:

- Exponentiation first, proceeding from left to right.
- Multiplication and division next, proceeding from left to right.
- Addition and subtraction last, proceeding from left to right.

- With the restriction that these rules are always applied working from the inner most set of nested parenthesis first and proceeding from left to right.



© Cengage Learning 2012

**FIGURE 7.54** Calculating the interior angle of a regular hexagon.

## WEB SITE RESEARCH

Use the following Web sites as a resource to help find more information related to engineering drawing and design and the content of this chapter.

Address	Company, Product, or Service
<a href="http://www.industrialpress.com">www.industrialpress.com</a>	Industrial Press. Online trigonometry tables.
<a href="http://www.g-w.com">www.g-w.com</a>	AutoCAD textbooks by Madsen.

# Chapter 7

## Chapter 7 Drafting Geometry Test



To access the Chapter 7 test, go to the Student CD, select **Chapter Tests and Problems**, and then **Chapter 7**. Answer the questions

with short, complete statements, sketches, or drawings as needed. Confirm the preferred submittal process with your instructor.

# Chapter 7 Drafting Geometry Problems

## INSTRUCTIONS

1. Problems 7.21 through 7.44 use an appropriately sized ASME sheet with sheet blocks and complete the title block information, unless otherwise specified by your instructor.
2. Use construction lines for all preliminary work on a construction layer. Use visible object lines for the completed problem. Leave the construction layer on when you complete the problems, unless otherwise specified by your instructor. This helps your instructor observe your drafting technique.
3. Geometric construction problems are presented as written instructions, drawings, or a combination of both. If the problems are presented as drawings without dimensions, then transfer the drawing from the text to your drawing sheet using 1:1 scales. Draw dimensioned problems full scale (1:1) unless otherwise specified. Draw all object, hidden, and centerlines. Do not draw dimensions.

### Part 1: Problems 7.1 Through 7.20

#### PROBLEM 7.1

Draw two tangent circles with their centers on a horizontal line. Circle 1 has a 64 mm diameter, and circle 2 has a 50 mm diameter.

#### PROBLEM 7.2

Make a perpendicular bisector of a horizontal line that is 79 mm long.

#### PROBLEM 7.3

Make an angle  $48^\circ$  with one side vertical. Bisect the angle.

#### PROBLEM 7.4

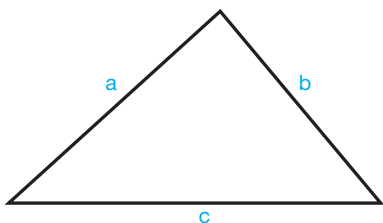
Divide a 96 mm line into seven equal spaces.

#### PROBLEM 7.5

Draw two parallel horizontal lines each 50 mm long with one 44 mm above the other. Divide the space between the lines into eight equal spaces.

#### PROBLEM 7.6

Transfer triangle abc to a new position with side c  $45^\circ$  from horizontal.



© Cengage Learning 2012

#### PROBLEM 7.7

Make a right triangle with one side 35 mm long and the other side 50 mm long.

#### PROBLEM 7.8

Make a right triangle with the hypotenuse 75 mm long and one side 50 mm long.

#### PROBLEM 7.9

Make an equilateral triangle with 65 mm sides.

#### PROBLEM 7.10

Make a square with a distance of 50 mm across the flats.

#### PROBLEM 7.11

Draw a hexagon with a distance of 2.5 in. across the flats.

#### PROBLEM 7.12

Draw a hexagon with a distance of 2.5 in. across the corners.

#### PROBLEM 7.13

Draw an octagon with a distance of 2.5 in. across the flats.

#### PROBLEM 7.14

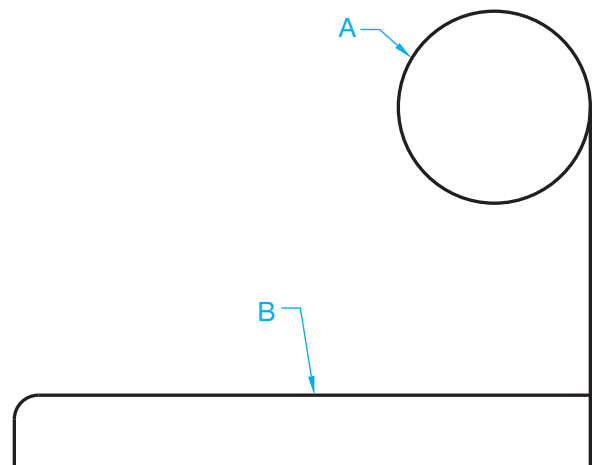
Draw a rectangle 50 mm  $\times$  75 mm with 12 mm radius tangent corners.

#### PROBLEM 7.15

Draw two separate angles, one a  $30^\circ$  acute angle and the other a  $120^\circ$  obtuse angle. Then draw a .5 in. radius arc tangent to the sides of each angle.

#### PROBLEM 7.16

Given the following incomplete part, draw an inside arc with a 2.5 in. radius tangent to  $\emptyset A$  and line B.



© Cengage Learning 2012

#### PROBLEM 7.17

Draw two circles with 25 mm diameters and 38 mm between centers on horizontal. On the upper side between the two circles, draw an inside radius of 44 mm. On the lower side, draw an outside radius of 76 mm.

**PROBLEM 7.18**

Draw an S curve with equal radii between points A and B given below:

A  
+

B  
+

© Cengage Learning 2012

**PROBLEM 7.19**

Draw two lines, one on each side of the ogee curve drawn in Problem 7.18 and .5 in. away.

**PROBLEM 7.20**

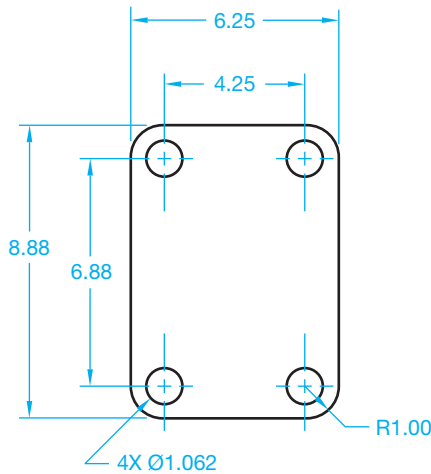
Make an ellipse with a 38 mm minor diameter and a 50 mm major diameter.

**Part 2: Problems 7.21 Through 7.44**

The following geometric construction problems are presented as dimensioned drawings or engineering problems. Draw dimensioned problems full scale (1:1) on an appropriately sized sheet with border and title block, unless otherwise specified by your instructor. Draw all object, hidden, and centerlines. Do not draw dimensions. Properly complete the information in the title block.

**PROBLEM 7.21 Circles, corner arcs, and tangencies (in.)**

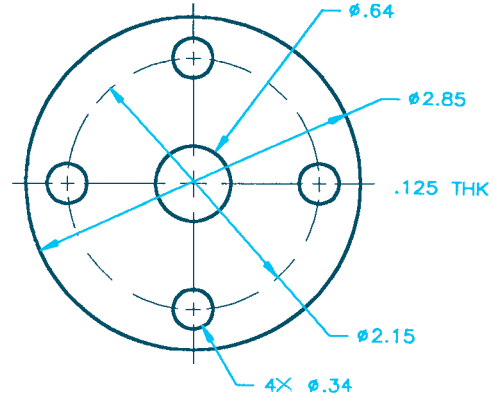
Part Name: Plate Spacer  
Material: .250 thick aluminum



© Cengage Learning 2012

**PROBLEM 7.22 Circles (in.)**

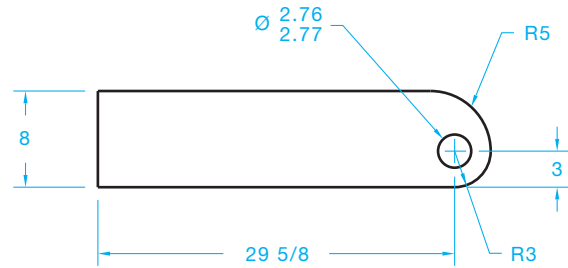
Part Name: Flange  
Material: .50 thick cast iron (CI)



© Cengage Learning 2012

**PROBLEM 7.23 Circle, arcs, and tangencies (in.)**

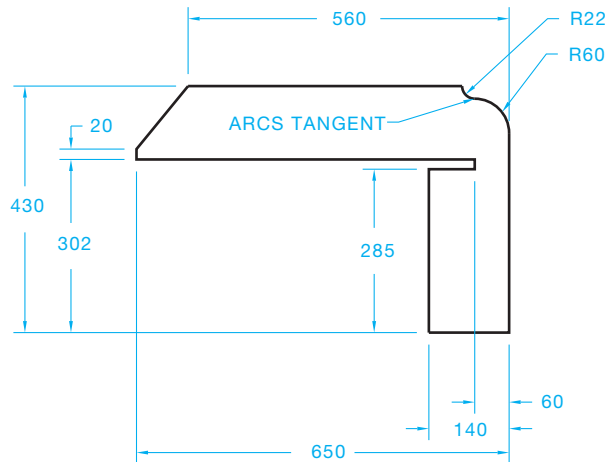
Part Name: Connector  
Material: .25 in. thick steel



© Cengage Learning 2012

**PROBLEM 7.24 Arc tangencies (metric)**

Part Name: Plate  
Material: 10 mm thick HC-112  
Used as a spacer to separate electronic components in a computer chassis.

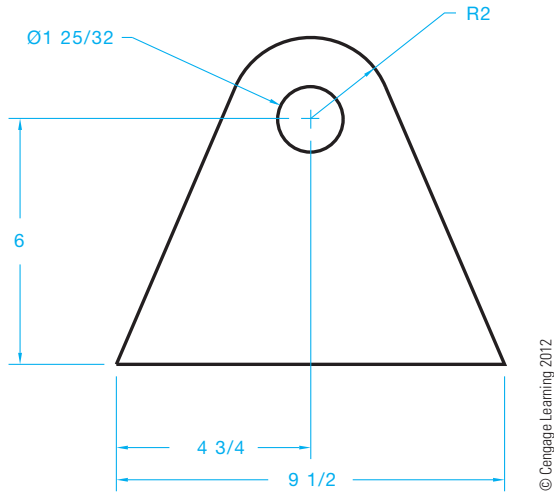


© Cengage Learning 2012

**PROBLEM 7.25** Circle, arc, and tangencies (in.)

Part Name: Bogie Lock

Material: .25 in. thick mild steel (MS)

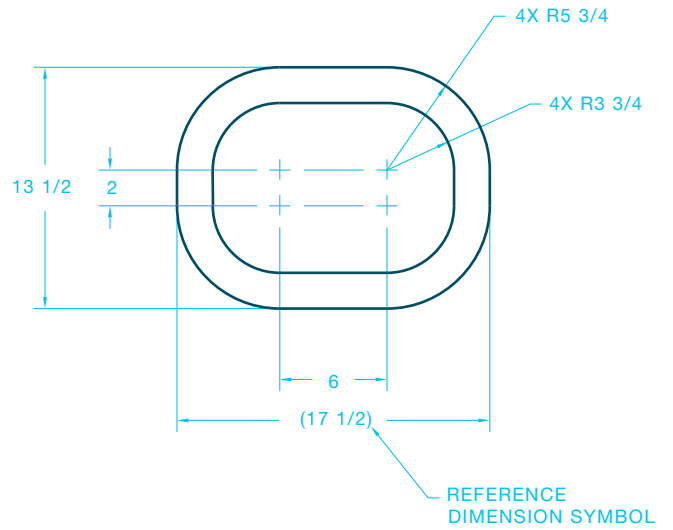


© Cengage Learning 2012

**PROBLEM 7.26** Arcs and tangencies (in.)

Part Name: Plate

Material: .125 in. thick aluminum

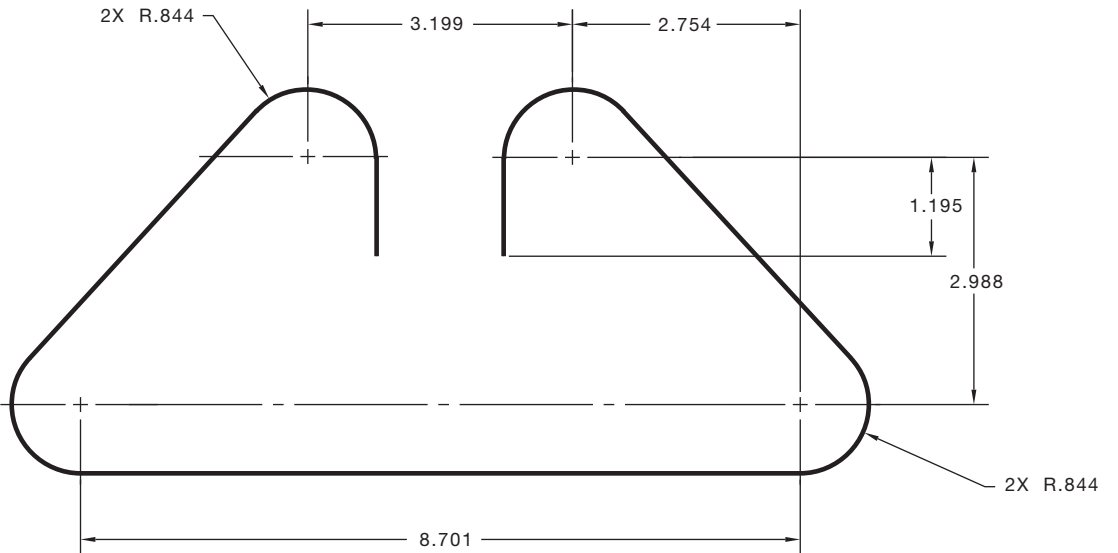


© Cengage Learning 2012

**PROBLEM 7.27** Arcs and tangencies (in.)

Part Name: Flat Spring

Material: 26 gauge X .50 SAE 1085

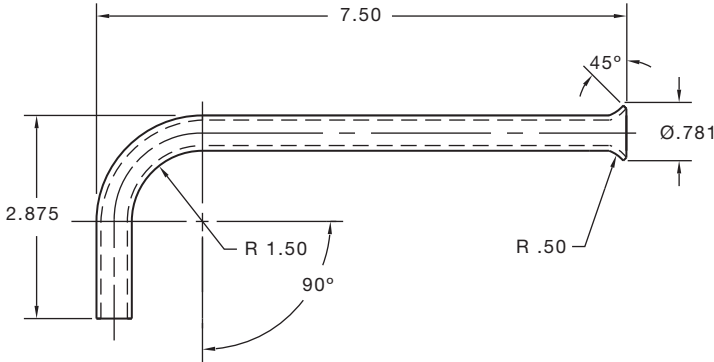


© Cengage Learning 2012



**PROBLEM 7.28 Arcs, centerlines, and hidden lines (in.)**

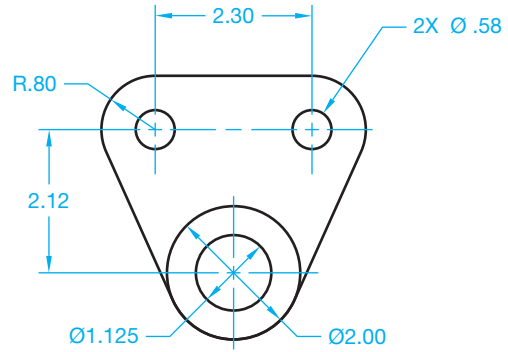
Part Name: Tube  
 Material: Copper  
 Outside Diameter: .75  
 Wall Thickness: .016



© Cengage Learning 2012

**PROBLEM 7.31 Circles, arcs, and tangencies (in.)**

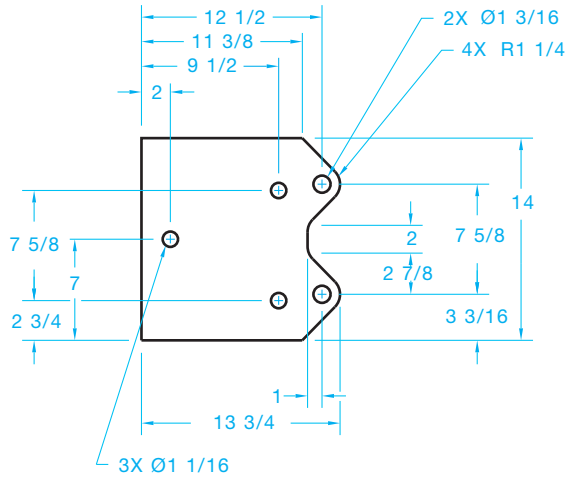
Part Name: Hanger  
 Material: Mild steel



© Cengage Learning 2012

**PROBLEM 7.29 Circles, arcs, and tangencies (in.)**

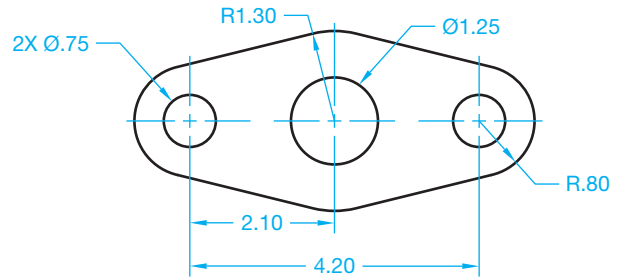
Part Name: Gasket  
 Material: .062 in. thick Neoprene



© Cengage Learning 2012

**PROBLEM 7.32 Circles, arcs, and tangencies (in.)**

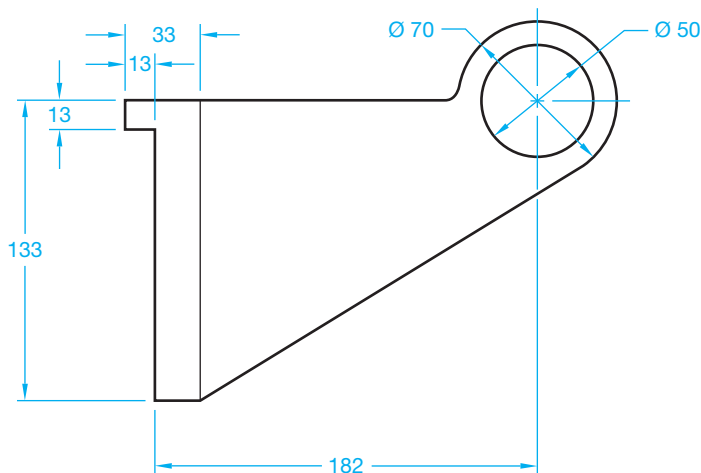
Part Name: Bracket  
 Material: Aluminum



© Cengage Learning 2012

**PROBLEM 7.30 Circle, arc, and tangencies (metric)**

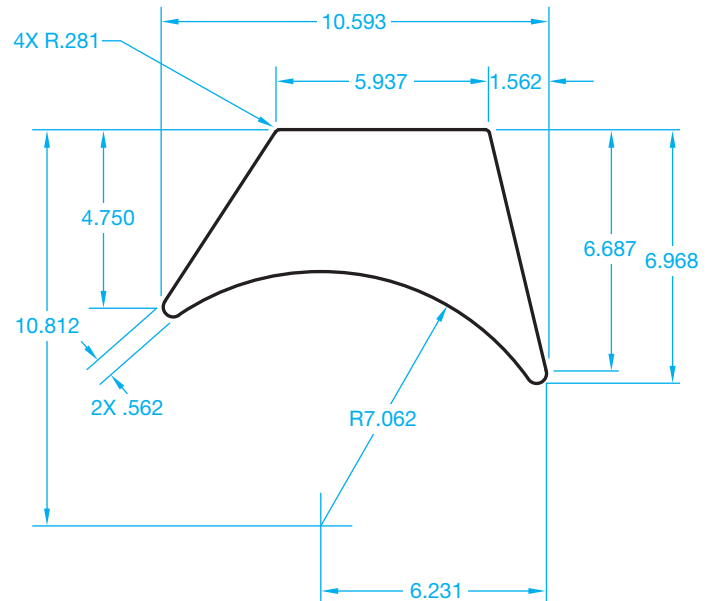
Part Name: Coupler  
 Material: SAE 1040



© Cengage Learning 2012

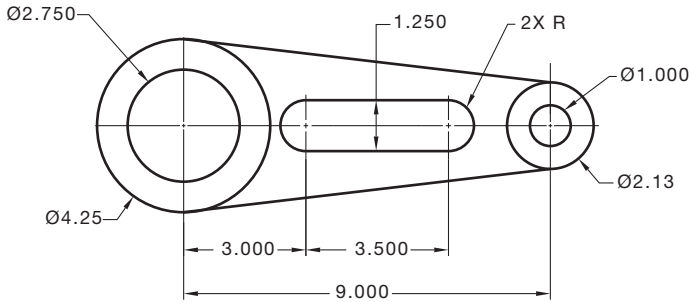
**PROBLEM 7.33 Arcs and tangencies (in.)**

Part Name: Gusset  
 Material: .250 thick aluminum  
 Courtesy TEMCO



**PROBLEM 7.34 Arcs, circles, and tangencies (in.)**

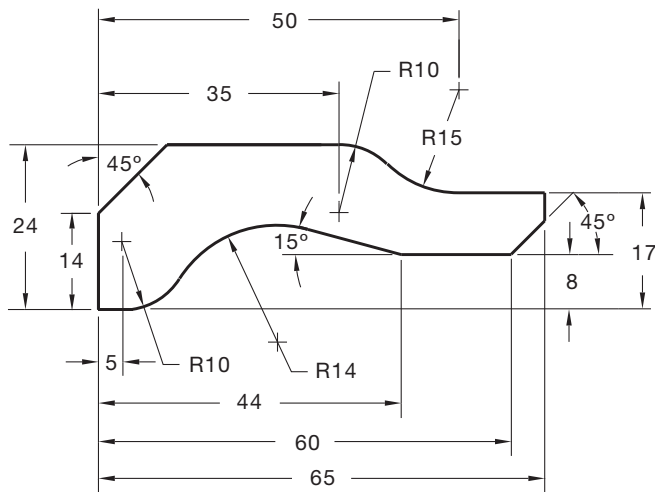
Part Name: Pivot Arm  
Material: Aluminum



© Cengage Learning 2012

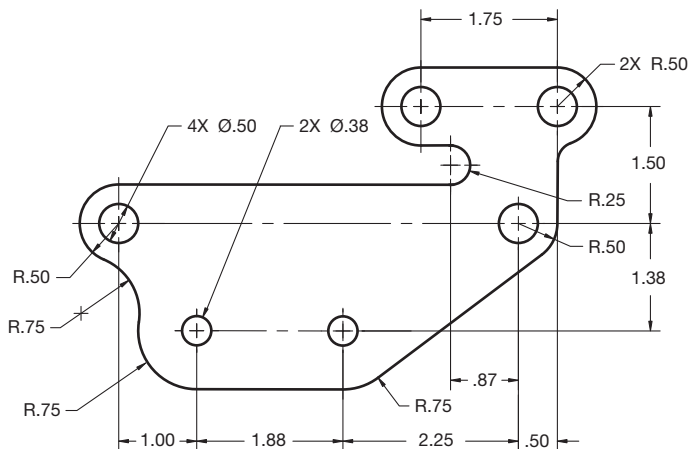
**PROBLEM 7.35 Arcs and angles (metric)**

Part Name: Support Brace  
Material: .125 in. thick copper



**PROBLEM 7.36 Arcs, circles, and tangencies (in.)**

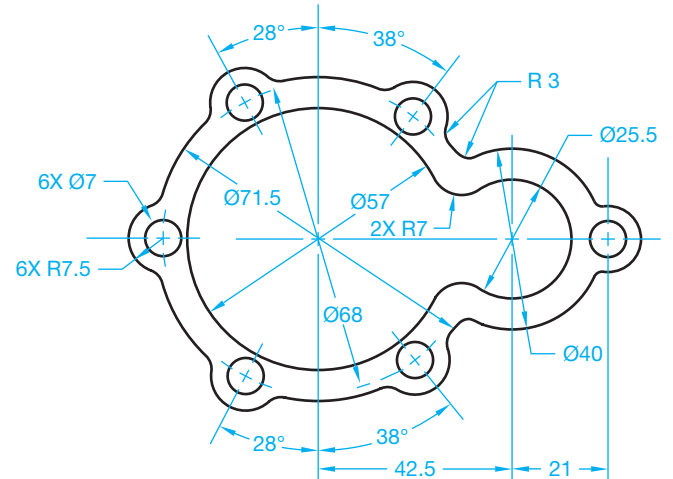
Part Name: Gasket  
Material: .0625 in. thick bronze



© Cengage Learning 2012

**PROBLEM 7.37 Circles, arcs, and tangencies (metric)**

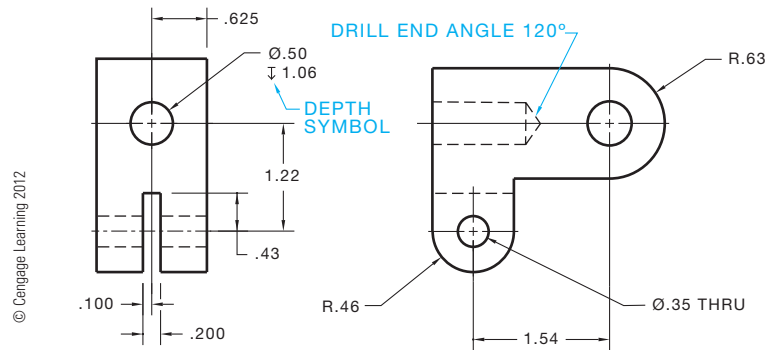
Part Name: Gasket  
Material: .06 in. thick cork



© Cengage Learning 2012

**PROBLEM 7.38 Multiviews (two views), circles, arcs, and tangencies (in.)**

Part Name: Bracket  
Material: Cast iron

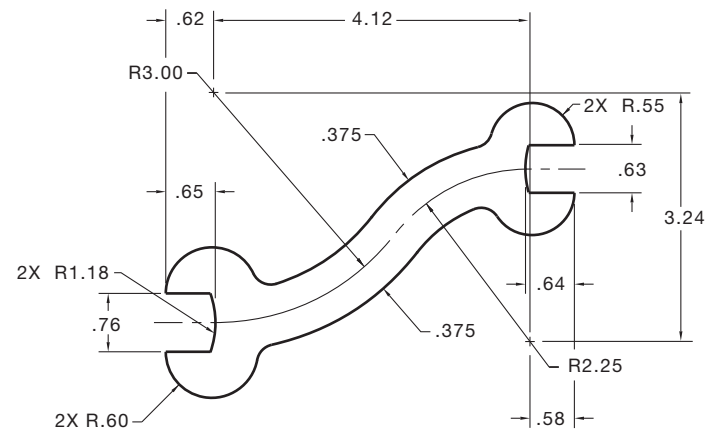


© Cengage Learning 2012

© Cengage Learning 2012

**PROBLEM 7.39 Ogee curve and arcs (in.)**

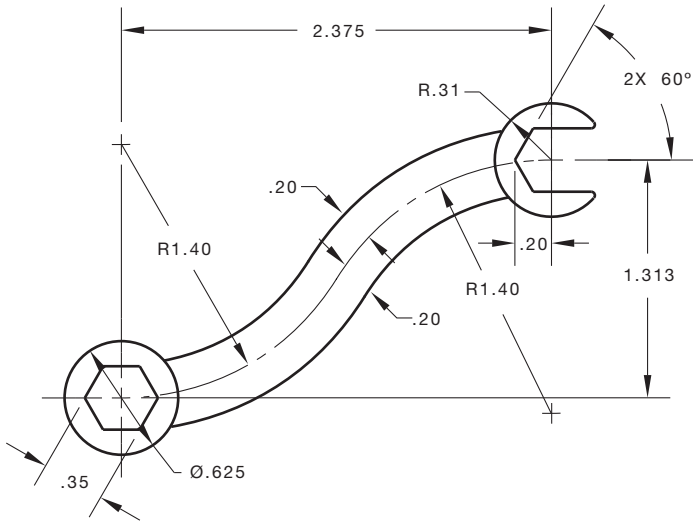
Part Name: Wrench  
Material: .25 in. thick cast iron  
Fillets and rounds:  $R.125$



© Cengage Learning 2012

**PROBLEM 7.40** Ogee curve, hexagon, and arcs (in.)

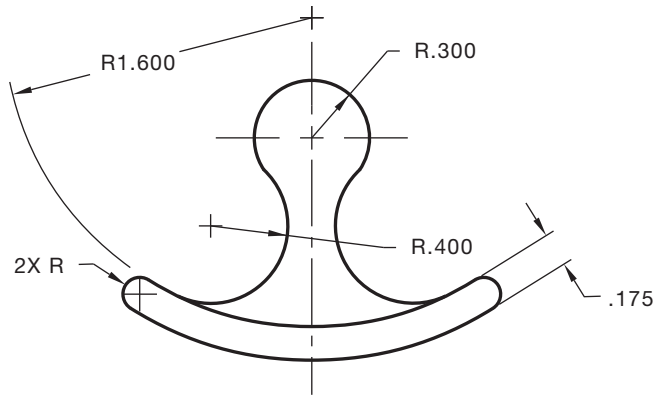
Part Name: Wrench  
 Material: .25 in. thick cast iron  
 Fillets and rounds R.125



© Cengage Learning 2012

**PROBLEM 7.41** Arc tangencies (in.)

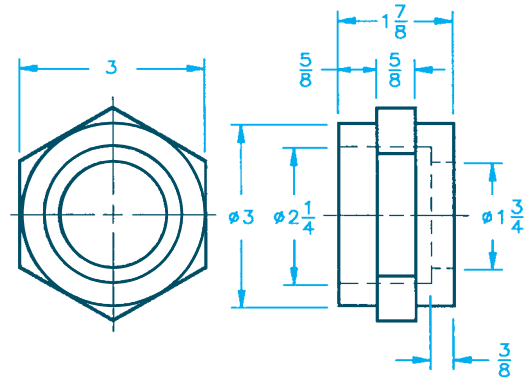
Part Name: Hammer Head  
 Material: Cast iron  
 Establish unknown dimensions to your own specifications.



© Cengage Learning 2012

**PROBLEM 7.42** Multiview and hexagon (in.)

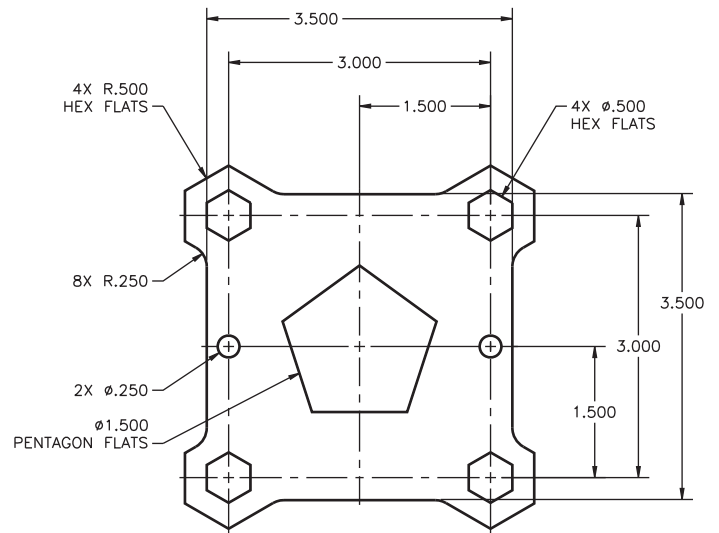
Part Name: Sleeve  
 Material: Bronze  
 Draw only the view with the hexagon and circles.  
 Note: This engineer's sketch shows dimensions to hidden features, which is not a standard practice.



© Cengage Learning 2012

**PROBLEM 7.43** Hexagons and pentagons (in.)

Part Name: Gasket  
 Material: .06 in. thick brass

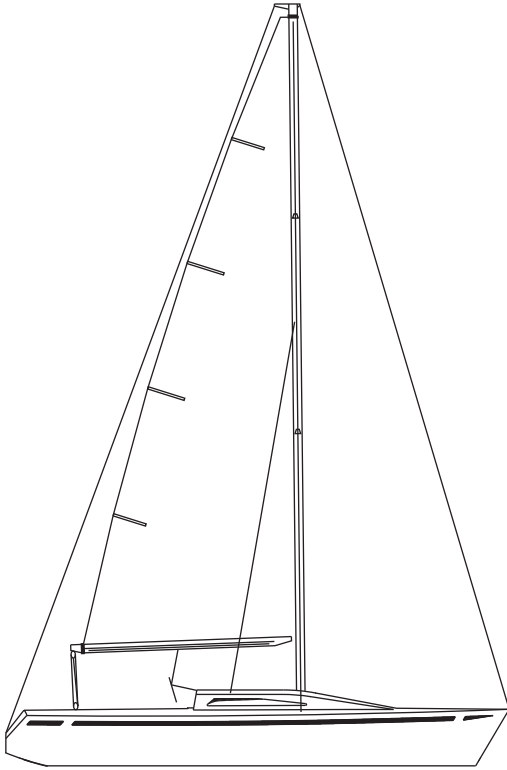


© Cengage Learning 2012

**PROBLEM 7.44 Design problem**

Part Name: Sailboat

Design the sailboat to your own specifications using the techniques discussed in this chapter.



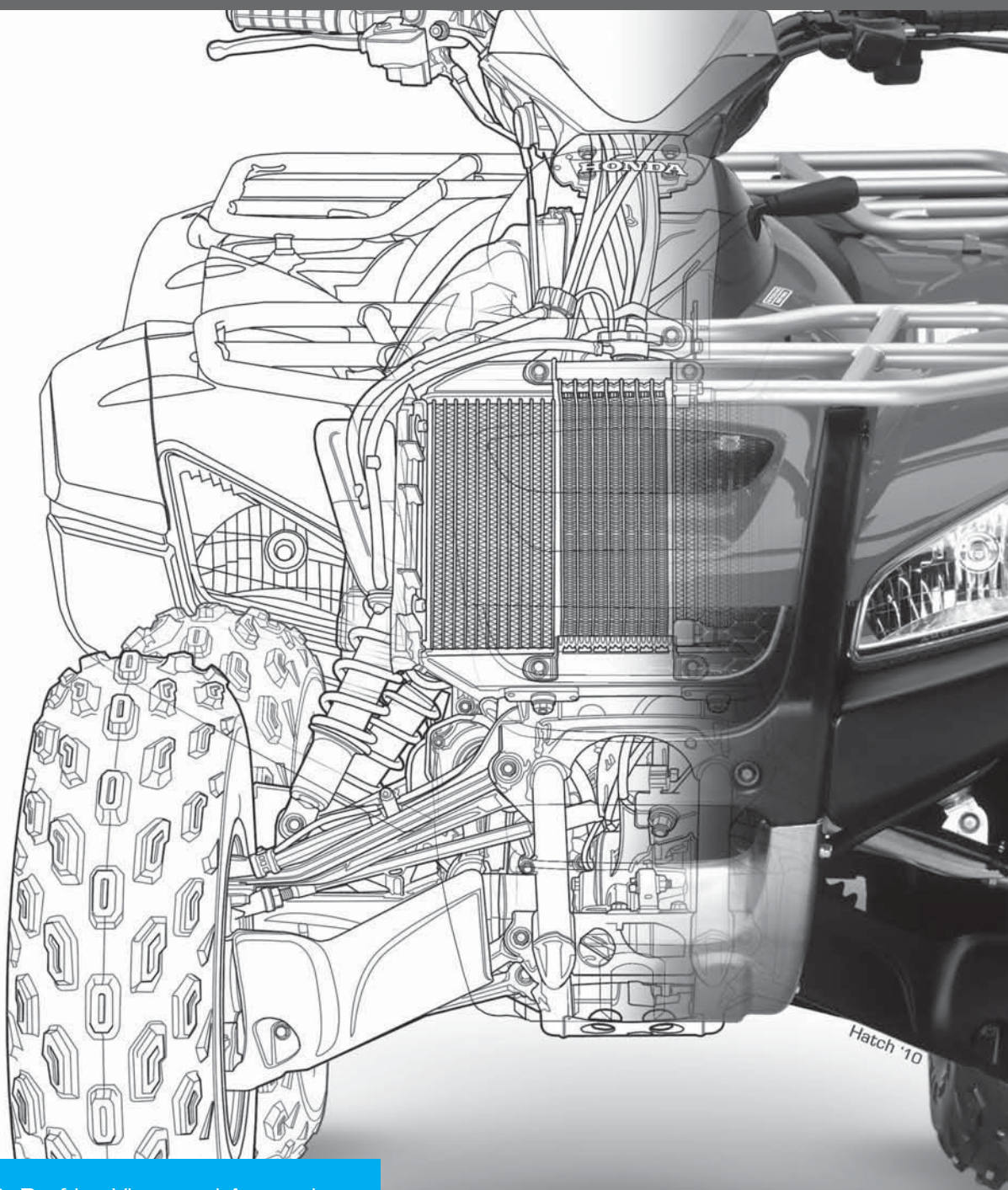
© Cengage Learning 2012

**Math Problems****Part 3: Problems 7.45 Through 7.50**

To access the Chapter 7 problems, go to the Student CD, select **Chapter Tests and Problems** and **Chapter 7**, and then open the math problem of your choice or as assigned by your instructor. Solve the problems using the instructions provided on the CD, unless otherwise specified by your instructor.



Drafting Views and Annotations



## Multiviews

### LEARNING OBJECTIVES

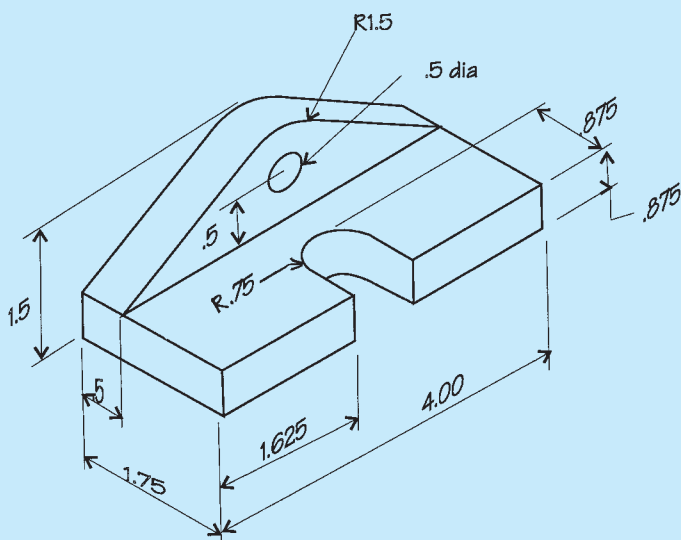
After completing this chapter, you will:

- Select appropriate views for presentation.
- Prepare single- and multiview drawings.
- Create detail views.
- Draw view enlargements.
- Establish runouts.
- Explain the difference between first- and third-angle projection.
- Create multiview drawings using first- and third-angle projection.
- Prepare formal multiview drawings from an engineer's sketch and actual industry layouts.

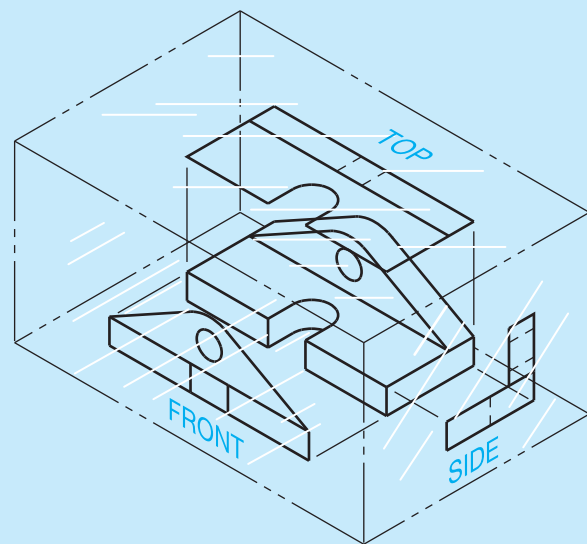
### THE ENGINEERING DESIGN APPLICATION

The engineer has just handed you a sketch of a new part design (see Figure 8.1). The engineer explains that a multiview drawing is needed on the shop floor as soon as possible so a prototype can be manufactured and tested. Your responsibility as the engineering drafter is to create a drawing that shows the appropriate number of views and all necessary manufacturing information.

Based on drafting guidelines, you first decide which view should be the front view. Having established the front view, you must now determine what other views are required in order to show all the features of the part. Using visualization techniques based on the glass box helps you to decide which views are needed (see Figure 8.2). Unfolding the box puts all of the views in



**FIGURE 8.1** Engineer's rough sketch.



**FIGURE 8.2** Using the glass box principle to visualize the needed views.

their proper positions. Now that you have properly visualized the part in your mind, you create a sketch of the proposed view layout. Using your sketch as a guide, you complete the formal drawing using the multiviews shown in Figure 8.3.

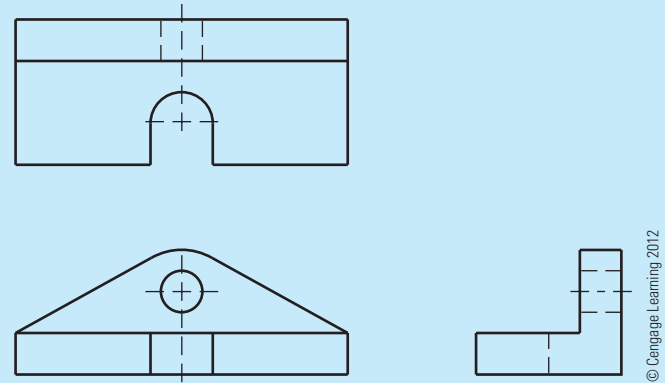


FIGURE 8.3 A multiview drawing of the part without dimensions.

© Cengage Learning 2012

STANDARDS

**ASME/ISO** This chapter is developed in accordance with the American Society of Mechanical Engineers (ASME) standards publication ASME Y14.3, *Multi and Sectional View Drawings*. The content of this discussion provides an in-depth analysis of the techniques and methods of multiview presentation. Defined and described in this chapter are practices related to orthographic projection, internationally recognized projection systems, and alternate view definition systems used by the International Organization for Standardization (ISO).

Actual objects such as your pencil, computer monitor, or this textbook are typically easy to recognize and visualize because they are three-dimensional (3-D) physical items. However, complex 3-D items are difficult to describe and can be even more complicated to draw and dimension because there is too much depth and extensive detail. As a result, the drafting industry has historically used a system of two-dimensional (2-D) views created using orthographic projection. Orthographic projection is used to change physical objects and 3-D ideas into 2-D drawings that effectively describe the design and features of an object, so the object can be documented and manufactured.

**Orthographic projection** is any projection of the features of an object onto an imaginary plane called a **plane of projection**. The projection of the features of the object is made by lines of sight that are perpendicular to the plane of projection. When a surface of the object is parallel to the plane of projection, the surface appears in its true size and shape on the plane of projection. The view that shows the actual shape of the object is called the **true geometry view**. In Figure 8.4, the plane of projection is parallel to the surface of the object. The line of sight (projection from the object) is perpendicular to the plane of projection. Notice also that the object appears three-dimensional (width, height, and depth) whereas the view on the plane of projection

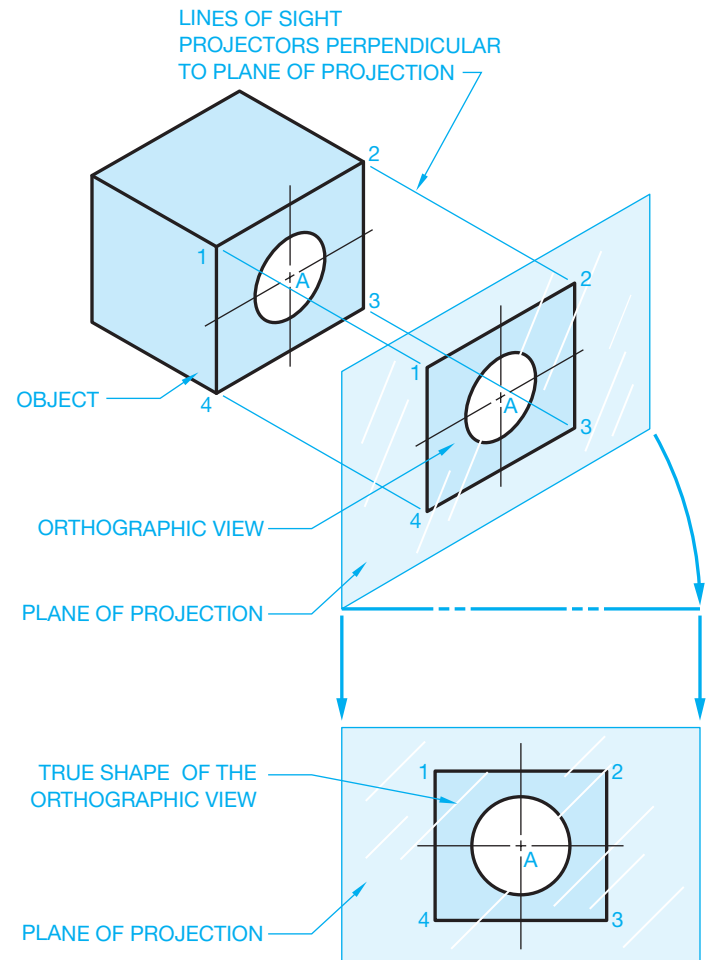


FIGURE 8.4 Orthographic projection to form orthographic view. © Cengage Learning 2012

has only two dimensions (width and height). In situations in which the plane of projection is not parallel to the surface of the object, the resulting orthographic view is foreshortened, or shorter than true length (see Figure 8.5).



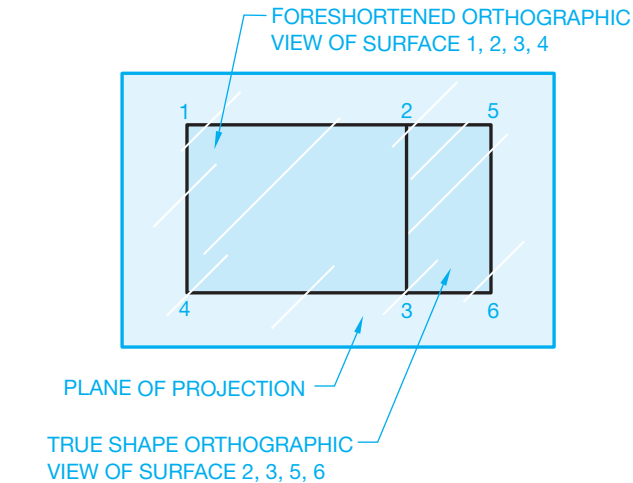
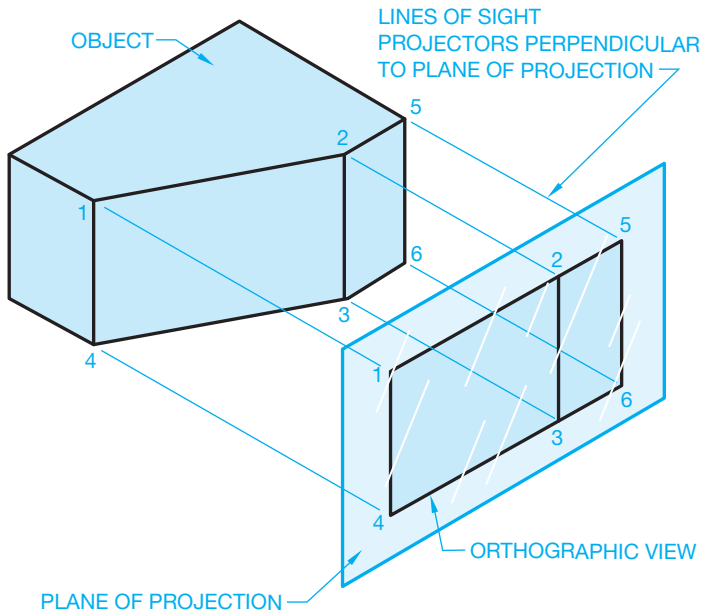


FIGURE 8.5 Projection of a foreshortened orthographic surface. © Cengage Learning 2012

## MULTIVIEWS

**Multiview projection** establishes views of an object projected on two or more planes of projection by using orthographic projection techniques. The result of multiview projection is a multiview drawing. A **multiview drawing** represents the shape of an object using two or more views. Consideration should be given to the choice and number of views used, so the surfaces of the object are shown in their true size and shape when possible.

It is generally easier to visualize a 3-D picture of an object than to visualize a 2-D drawing. In mechanical drafting, however, the common practice is to prepare completely dimensioned detail drawings using 2-D views known as **multiviews**. Figure 8.6 shows an object represented by a 3-D drawing, also called a **pictorial**, and three 2-D views, or multiviews, also known as orthographic projection. The multiview method of drafting represents the **shape description** of the object.

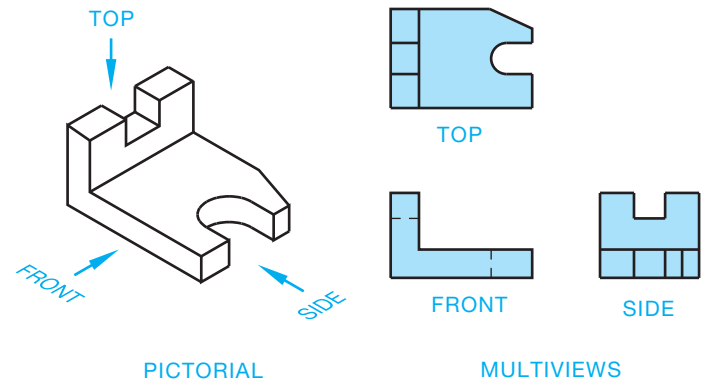


FIGURE 8.6 A pictorial view and its relationship to multiviews of the same part. © Cengage Learning 2012

## The Glass Box Visualization Method

If the object in Figure 8.6 is placed in a glass box so the sides of the box are parallel to the major surfaces of the object, you can project those surfaces onto the sides of the glass box and create multiviews. Imagine the sides of the glass box are the planes of projection previously discussed (see Figure 8.7). If you look at all sides of the glass box, then you have six total views: front, top, right side, left side, bottom, and rear. Now unfold the glass box as if the corners were hinged about the front (except the rear view) as demonstrated in Figure 8.8. These hinge lines are commonly called **fold lines** or **reference lines**.

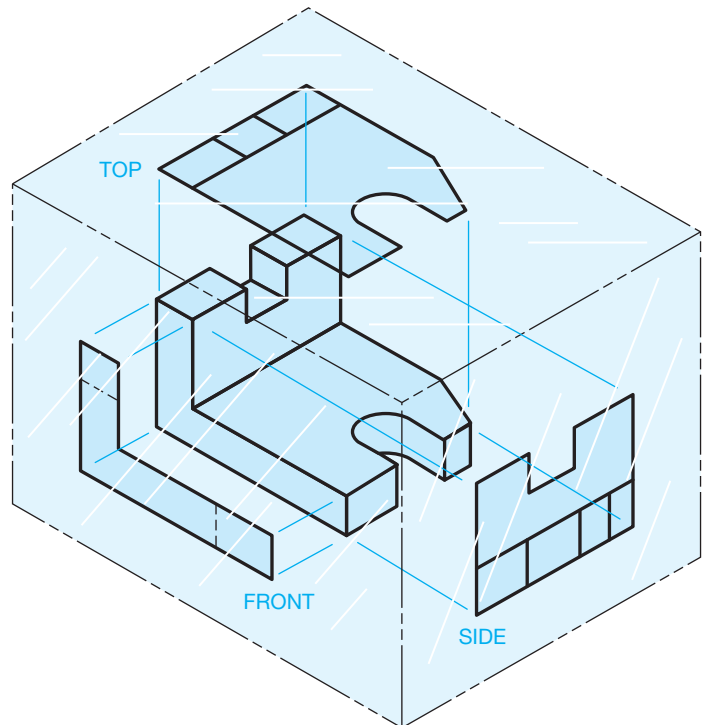
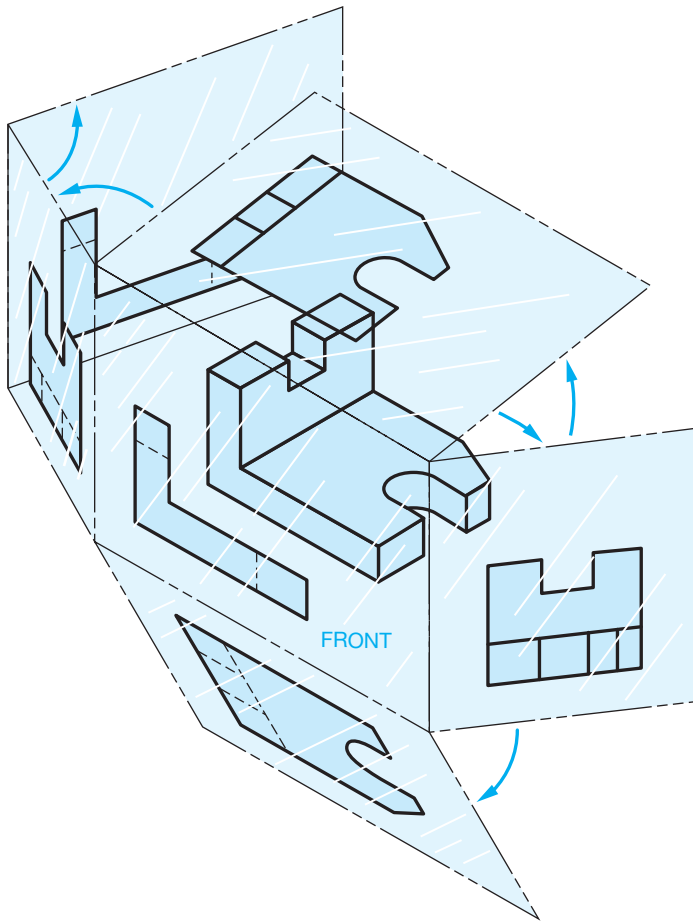
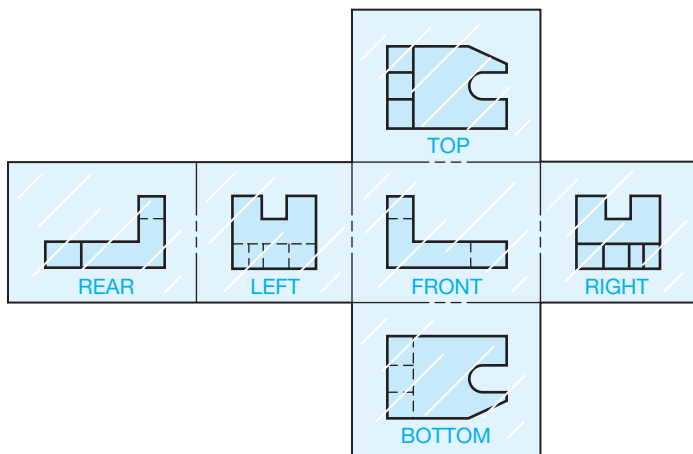


FIGURE 8.7 The glass box principle. © Cengage Learning 2012



**FIGURE 8.8** Unfolding the glass box at the hinge lines, also called *fold lines* or *reference lines*. © Cengage Learning 2012



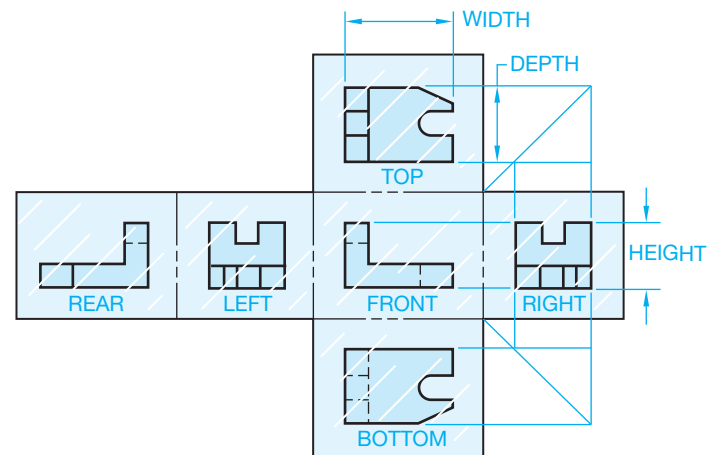
**FIGURE 8.9** Glass box unfolded. © Cengage Learning 2012

Completely unfold the glass box onto a flat surface and you have the six views of an object represented in multiview. Figure 8.9 shows the glass box unfolded. Notice the views are labeled FRONT, TOP, RIGHT, LEFT, REAR, and BOTTOM. This is the arrangement that the views are always found in when using multiviews in third-angle projection. **Third-angle**

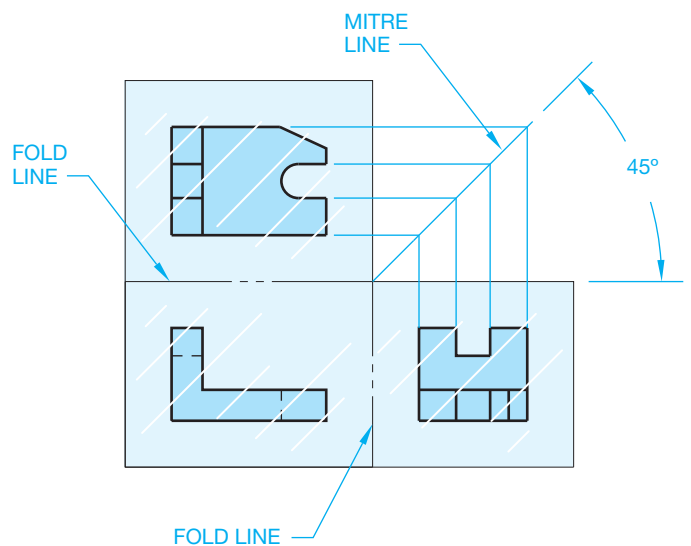
**projection** is the principal multiview projection used in the United States. **First-angle projection** is commonly used in other countries. Additional third- and first-angle projection coverage is provided later in this chapter.

Look at Figure 8.9 in more detail so you can observe the common items between views. Knowing how to identify features of the object common between views aids you in visualizing multiviews. Notice in Figure 8.10 that the views are aligned. The top view is directly above and the bottom view is directly below the front view. The left-side view is directly to the left and the right-side view is directly to the right of the front view. This format allows you to project points directly from one view to the next to help establish related features on each view.

Now look closely at the relationships between the front, top, and right-side views. A similar relationship exists with the left-side view. Figure 8.11 shows a 45° line projected from the corner of the fold between the front, top, and side views. The 45° line is often called a **mitre line**. This 45° line is used as an aid



**FIGURE 8.10** View alignment. © Cengage Learning 2012



**FIGURE 8.11** The 45° projection line.

in projecting views between the top and right-side views in this example. All of the features established on the top view can be projected to the 45° line and then down onto the side view. This projection works because the depth dimension is the same between the top and side views. The reverse is also true. Features from the side view can be projected to the 45° line and then over to the top view.

The same concept of projection developed in Figure 8.11 using the 45° line also works by using arcs with the arc center at the intersection of the horizontal and vertical fold lines. The arcs establish the common relationship between the top and side views as shown in Figure 8.12. Another method commonly used to transfer the size of features from one view to the next is to use measurements to transfer distances from the fold line of the top view to the fold line of the side view. The relationships between the fold line and these two views are the same, as shown in Figure 8.13.

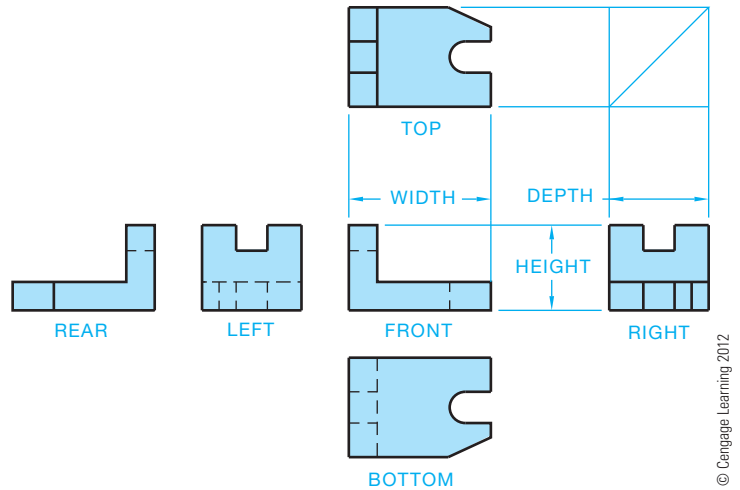


FIGURE 8.14 Multiview orientation of the six principal views.

The front view is usually the most important view and the one from which the other views are established. There is always one dimension common between adjacent views. For example, the width is common between the front and top views, and the height is common between the front and side views. Knowing this allows you to relate information from one view to another. Look again at the relationship between the six views shown in Figure 8.14.

### THIRD-ANGLE PROJECTION

The primary method of multiview projection described in this chapter is known as third-angle projection. Third-angle projection is the method of view arrangement commonly used in the United States. In the previous discussion on multiview projection, the object was placed in a glass box so the sides of the glass box were parallel to the major surfaces of the object. Next, the object surfaces were projected onto the adjacent surfaces of the glass box. This gave the same effect as if your line of sight is perpendicular to the surface of the box and looking directly at the object, as shown in Figure 8.15. With the multiview concept in mind, assume an area of space is divided into four quadrants, as shown in Figure 8.16.

If the object is placed in any of these quadrants, the surfaces of the object are projected onto the adjacent planes. When placed in the first quadrant, the method of projection is known as *first-angle projection*. Projections in the other quadrants are termed *second-, third-, and fourth-angle projections*. Second- and fourth-angle projections are not used, though first- and third-angle projections are common.

Third-angle projection is established when you take the glass box from Figure 8.15 and place it in quadrant 3 from Figure 8.16. Figure 8.17 shows the relationship of the glass box to the projection planes in the third-angle projection. In this quadrant, the projection plane is between your line of sight and

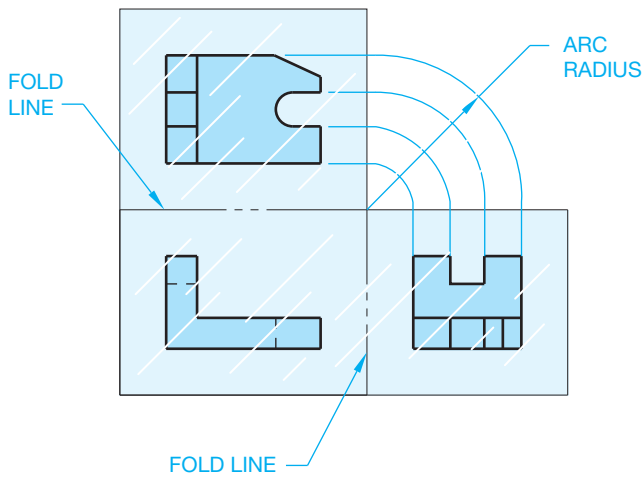


FIGURE 8.12 Projection between views with arcs.

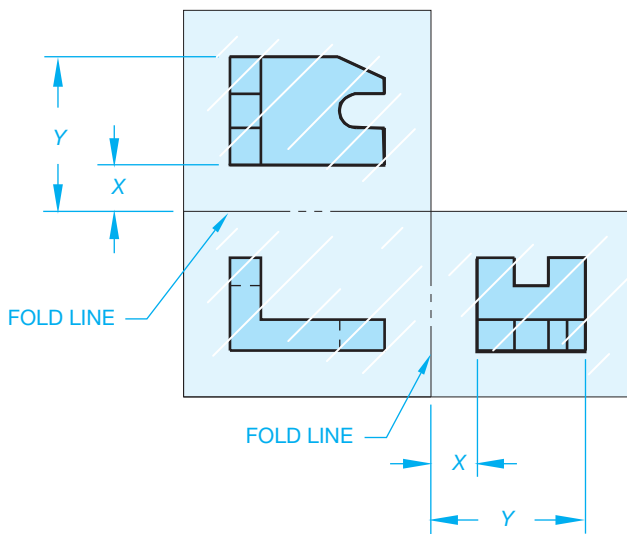


FIGURE 8.13 Using measurements to transfer view projections.

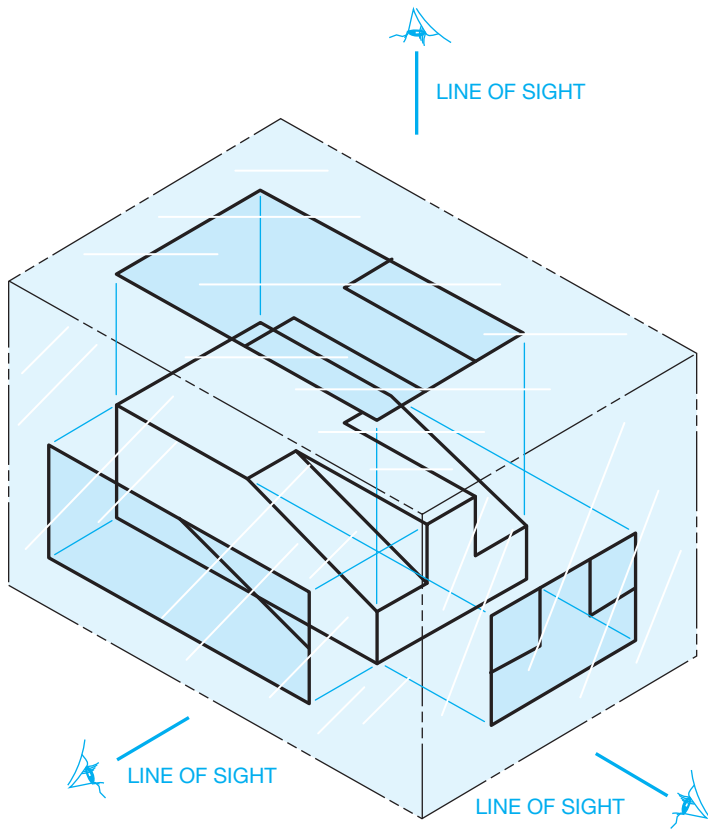


FIGURE 8.15 Glass box in third-angle projection. © Cengage Learning 2012

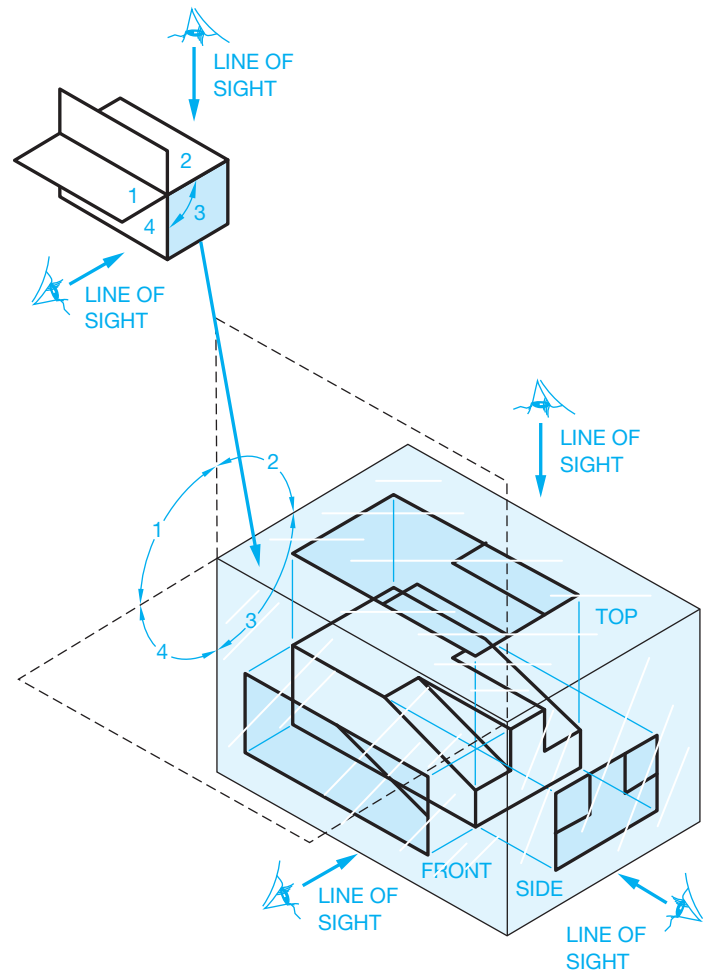


FIGURE 8.17 Glass box placed in the third quadrant for third-angle projection. © Cengage Learning 2012

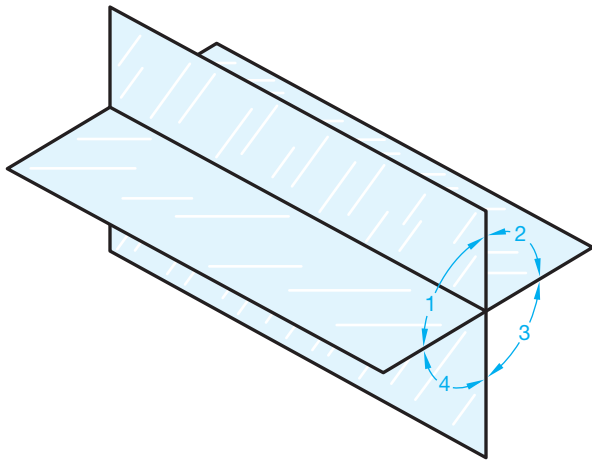


FIGURE 8.16 Quadrants of spatial visualization. © Cengage Learning 2012

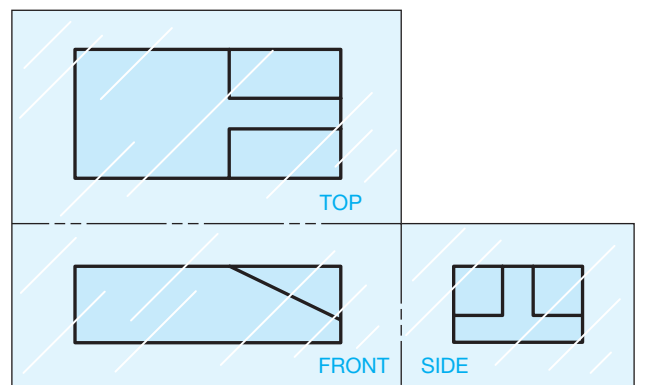
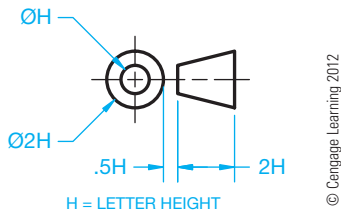


FIGURE 8.18 Views established using third-angle projection.

the object. When the glass box in the third-angle projection quadrant is unfolded, the result is the multiview arrangement previously described and shown in Figure 8.18.

A third-angle projection drawing is identified by the third-angle projection symbol. The angle of projection symbol typically appears in the angle of projection block

near the title block, as shown in Chapter 2, *Drafting Equipment, Media, and Reproduction Methods*. Figure 8.19 shows the standard third-angle projection symbol as specified by ASME Y14.3.

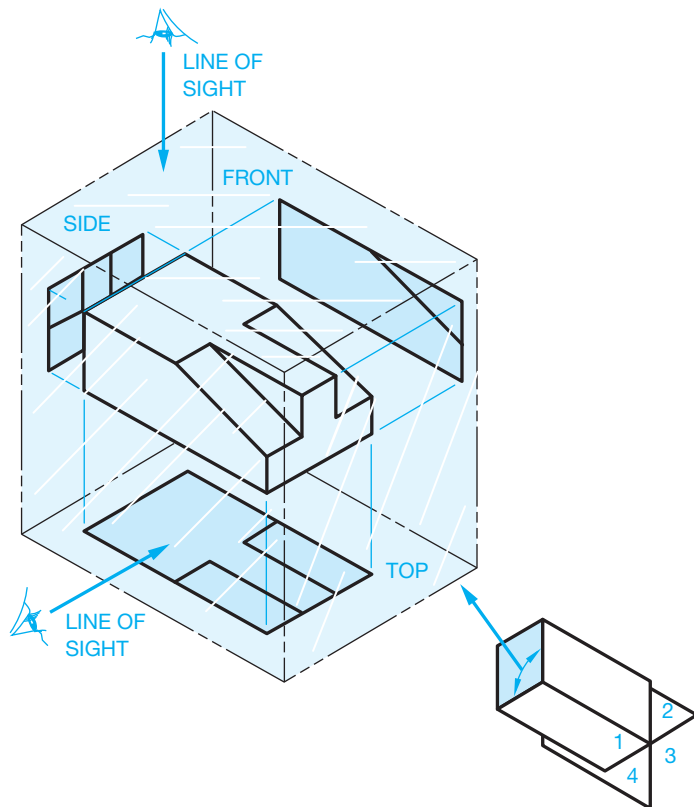


**FIGURE 8.19** Third-angle projection symbol. ASME Y14.3 defines the projection symbol dimensions based on a .12 in. (3 mm) letter height. A larger symbol is usually more appropriate for use in the angle of projection block.

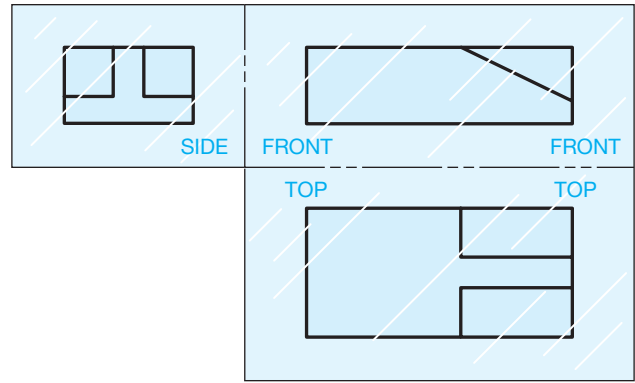
### FIRST-ANGLE PROJECTION

First-angle projection is commonly used in countries other than the United States. First-angle projection places the glass box in the first quadrant of Figure 8.16. Views are established by projecting surfaces of the object onto the surface of the glass box. In this projection arrangement, the object is between your line of sight and the projection plane, as shown in Figure 8.20. When the glass box in the first-angle projection quadrant is unfolded, the result is the multiview arrangement shown in Figure 8.21.

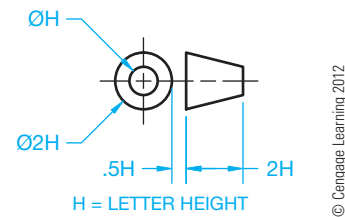
A first-angle projection drawing is identified by the first-angle projection symbol. The angle of projection symbol typically appears in the angle of projection block near the title block, as shown in Chapter 2, *Drafting Equipment, Media, and Reproduction Methods*. Figure 8.22 shows the standard first-angle



**FIGURE 8.20** Glass box in first-angle projection. © Cengage Learning 2012



**FIGURE 8.21** Views established using first-angle projection.



**FIGURE 8.22** First-angle projection symbol. ASME Y14.3 defines the projection symbol dimensions based on a .12 in. (3 mm) letter height. A larger symbol is usually more appropriate for use in the angle of projection block.

projection symbol as specified by ASME Y14.3. Figure 8.23 shows a comparison of the same object in first- and third-angle projections.

### VIEW SELECTION

Although there are six primary views that you can select to describe an object completely, it is seldom necessary to use all six views. As a drafter, you must decide how many views are needed to represent the object properly. If you draw too many views, you make the drawing too complicated and are wasting time, which costs your employer money. If you draw too few views, then you have not completely described the object. The manufacturing department then has to waste time trying to determine the complete description of the object, which again costs your employer money.

#### Selecting the Front View

Usually, you should select the front view first. The front view is generally the most important view and, as you learned from the glass box description, it is the origin of all other views. There is no exact way for everyone to select the same front view always, but there are some guidelines to follow. The front view should:

- Represent the most natural position of use.
- Provide the best shape description or most characteristic contours.

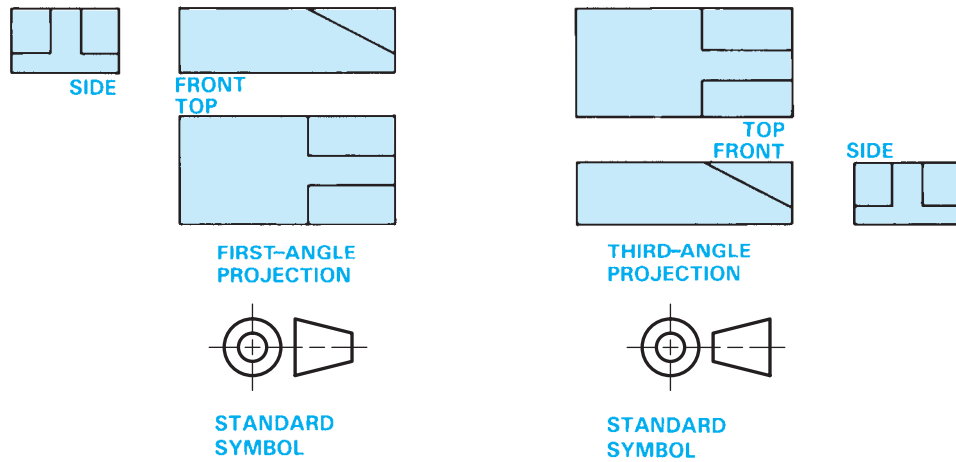


FIGURE 8.23 First-angle and third-angle projection compared.

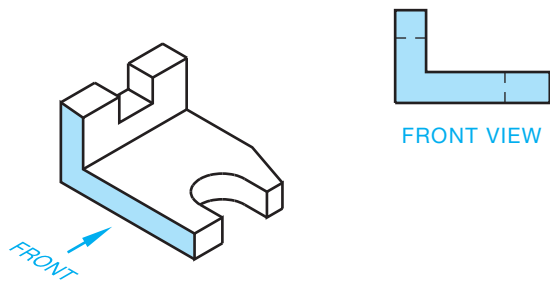


FIGURE 8.24 Front-view selection.

- Have the longest dimension.
- Have the fewest hidden features.
- Be the most stable and natural position.

Look at the pictorial drawing in Figure 8.24. Notice the front-view selection. This front-view selection violates the guidelines for best shape description and the fewest hidden features. However, the selection of any other view as the front would violate other rules, so in this case there is possibly no correct answer. Given the pictorial drawings in Figure 8.25, identify the view that you believe is the best front view for each object. The figure caption provides possible answers. More than one answer is given for some of the objects, with the first answer being the preferred choice.

### Selecting Two or Three Views

Use the same rules when selecting other views needed as you do when selecting the front view:

- Most contours.
- Longest side.
- Least hidden features.
- Best balance or position.

Given the six views of the object in Figure 8.26, which views would you select to describe the object completely? If your

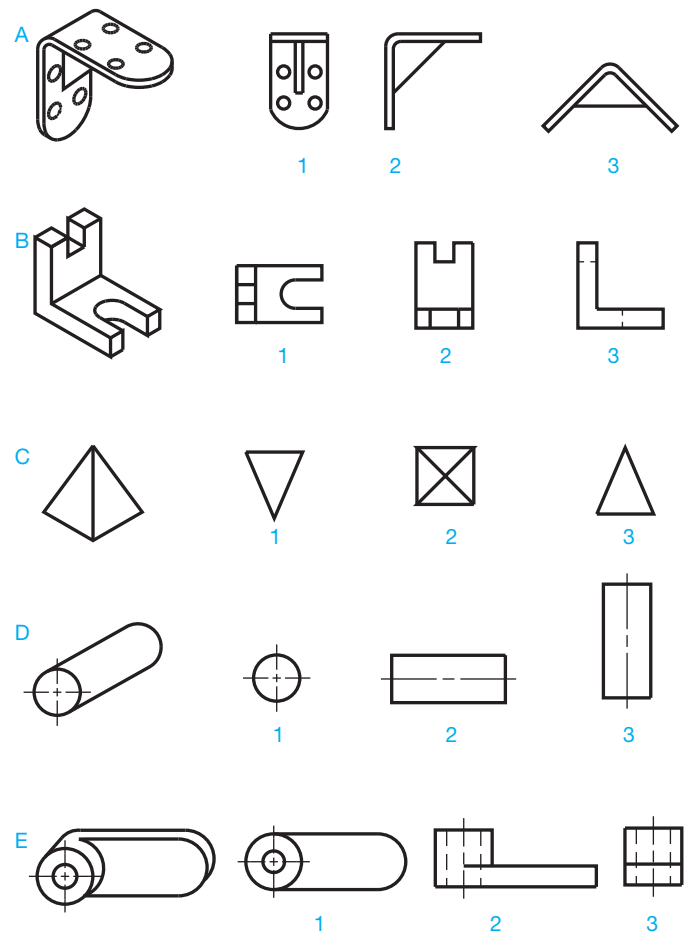


FIGURE 8.25 Select the best front views that correspond to the pictorial drawings at the left. You can make a first and second choice. © Cengage Learning 2012

selection is the front, top, and right side, then you are correct. Now take a closer look. Figure 8.27 shows the selected three views. The front view shows the best position and the longest side, the top view clearly represents the angle and the arc, and

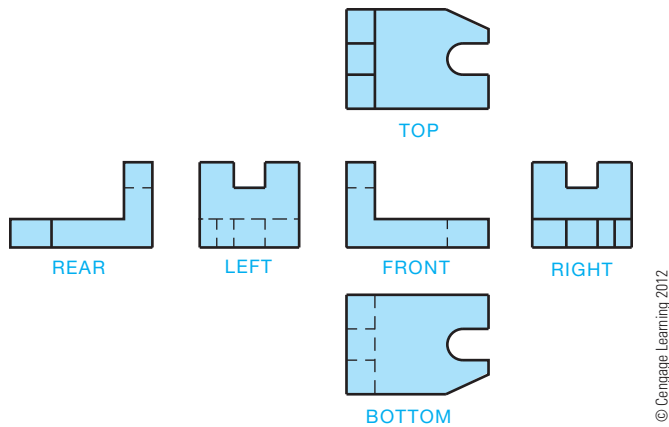


FIGURE 8.26 Select the necessary views to describe the object from the six principal views available.

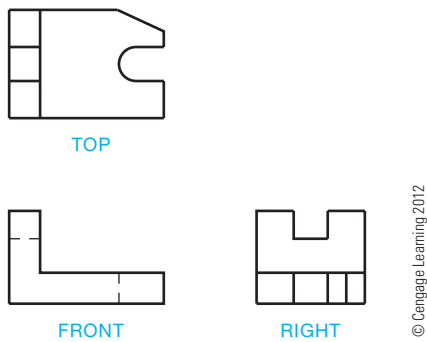


FIGURE 8.27 The three selected views.

the right-side view shows the notch. Any of the other views have many more hidden features. You should always avoid hidden features if you can.

**NOTE:** Look at Figures 8.26 and 8.27 and notice the front view that this drafter selected. Now look at the rear view in Figure 8.26. You can easily argue that the drafter could have selected the rear view in Figure 8.26 as the preferred front view, and you would be correct. The rear view in Figure 8.26 has an object line representing a corner, where the front view has a hidden line. Keeping with the idea of minimizing hidden lines, the drafter probably should have selected the current rear view as the front view. The views that this drafter selected in Figure 8.27 still work to display the shape of the part, but the rear view would have been a better choice. This is the thinking process that you need to go through when selecting views.

It is not always necessary to select three views. Some objects can be completely described with two views or even one view. When selecting fewer than three views to describe an object, you must be careful which view, other than the front view, you select. Look at Figure 8.28a and notice the two views that are selected for each object. Whenever possible, spend some time looking at actual industry drawings. Doing this gives you

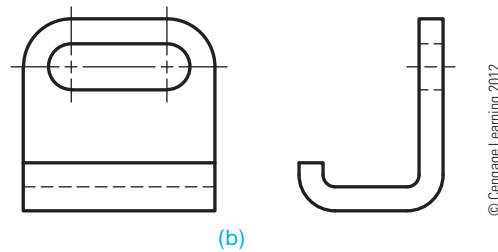
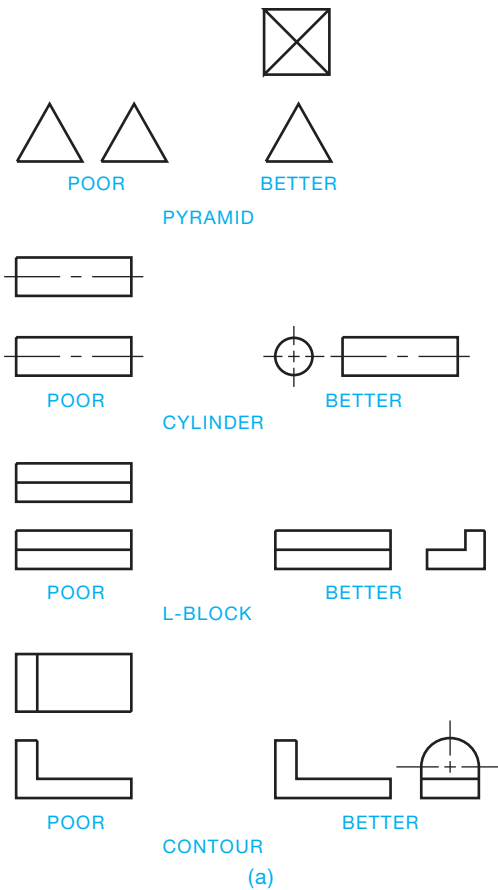


FIGURE 8.28 (a) Selecting two views of objects. (b) A two-view drawing.

a better understanding of how the views of an object are arranged. Figure 8.28b shows a two-view drawing.

Figure 8.29 is an industry drawing showing an object displayed using three views. Try to visualize the shape of this object in your mind and decide if you agree with the view selection provided by the person who created this drawing.

### One-View Drawings

One-view drawings are also often practical. When an object has a uniform shape and thickness, more than one view is normally unnecessary. Figure 8.30 shows a gasket drawing in which the thickness of the part is identified in the materials specifications of the title block. The types of parts that easily fit into the one view category include gaskets, washers, spacers, and similar thin features.

Although two-view drawings are generally considered the minimum recommended views for a part, objects that are clearly

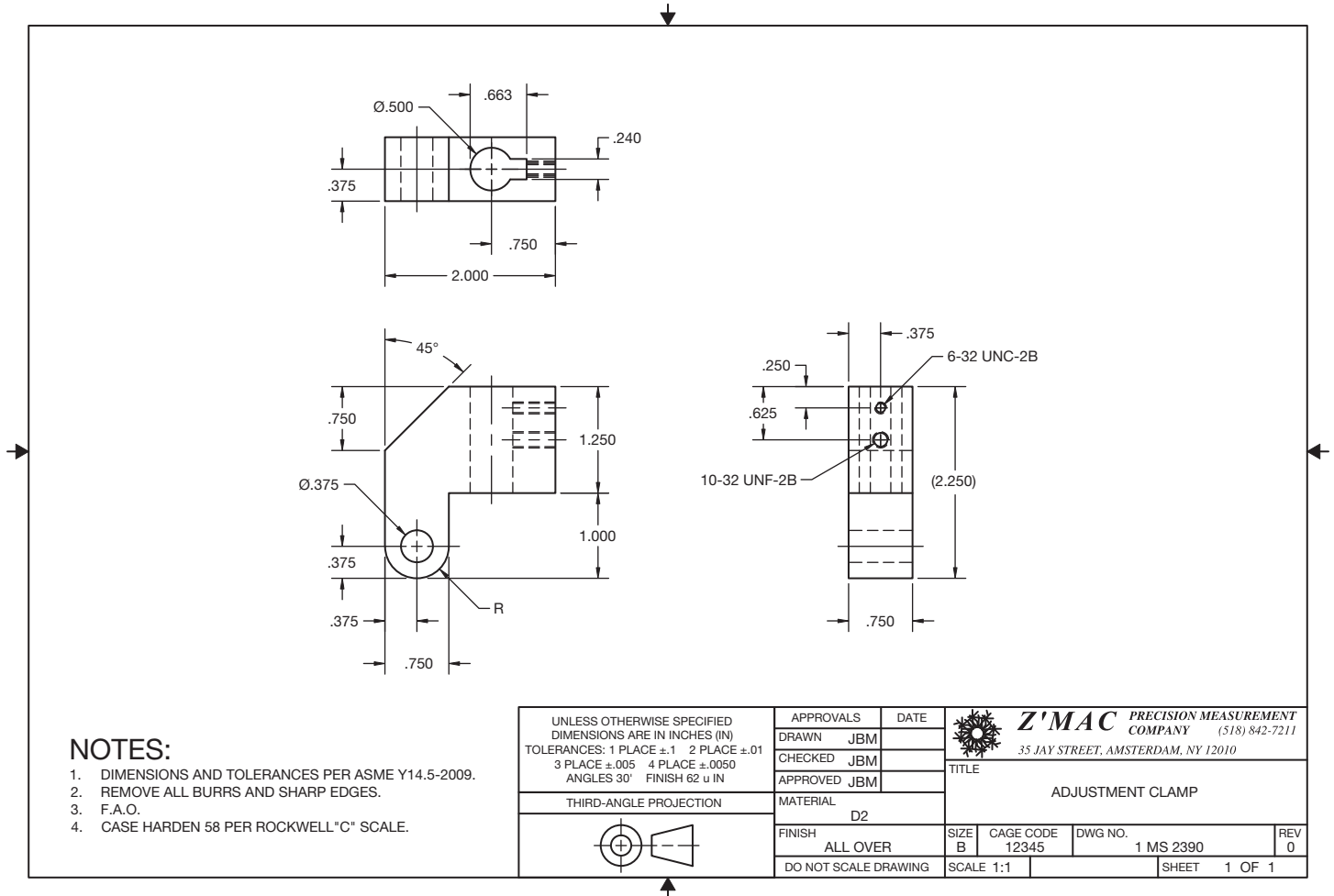


FIGURE 8.29 An actual industry drawing with three views used to describe the part. Courtesy Jim B. MacDonald

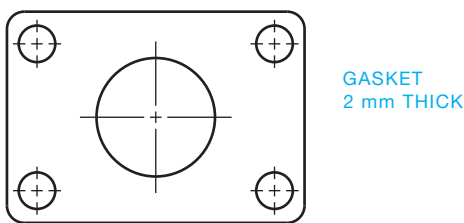


FIGURE 8.30 One-view drawing with thickness given in a note.

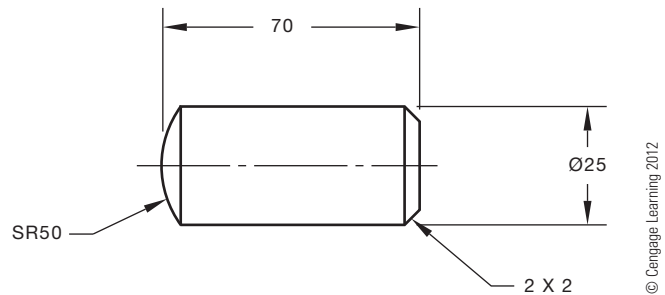


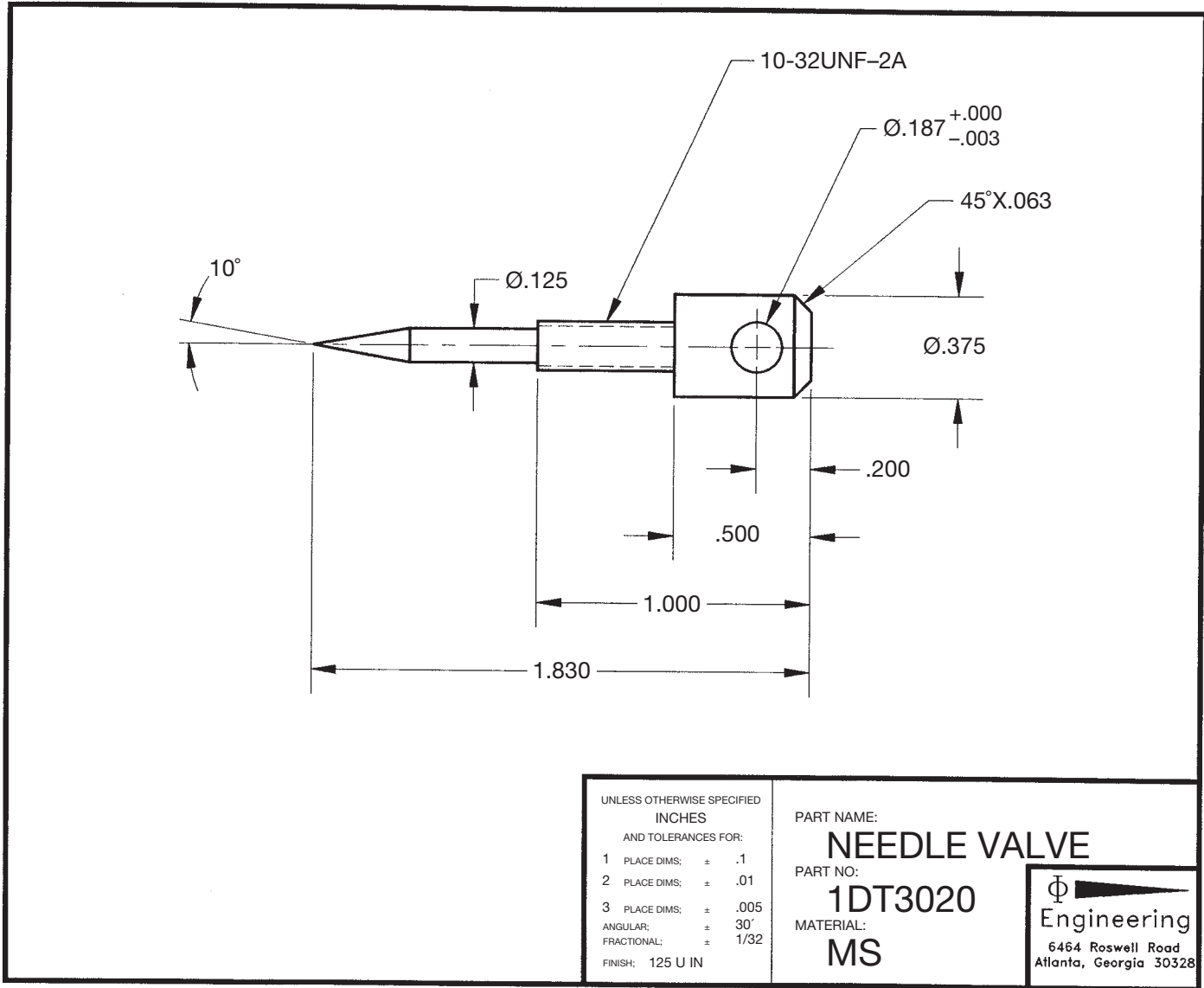
FIGURE 8.31 One-view drawing with the diameter specified in a dimension.

identified by shape and dimensional information can be drawn with one view as shown in Figure 8.31. In Figure 8.31, the shape of the pin is clearly identified by the 25 mm diameter. In this case, the second view would be a circle and would not necessarily add any more valuable information to the drawing. Keep this primary question in mind: Can the part be easily manufactured from the drawing without confusion? If there is any doubt, then the adjacent view should probably be drawn. As an entry-level drafter, you should ask your drafting supervisor to clarify the company policy regarding the number of views to be drawn. Figure 8.32 provides an actual industry drawing of an object with one view.

## Partial Views

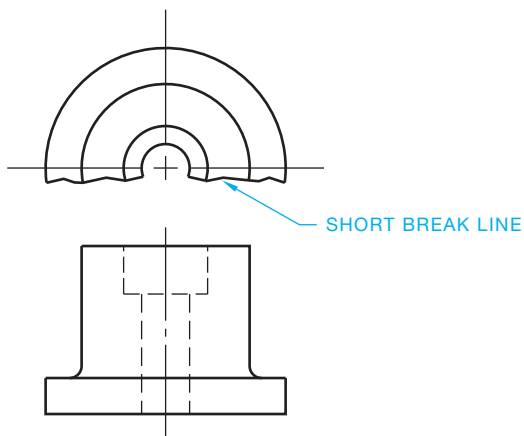
**Partial views** can be used when symmetrical objects are drawn in limited space or when there is a desire to simplify complex views. The top view in Figure 8.33 is a partial view. Notice how the short break line is used to show that a portion of the view is omitted. Caution should be exercised when using partial views, as confusion could result in some situations. If the partial view reduces clarity, then draw the entire view. When using CADD, it is easier to draw the full view.





Courtesy of Engineering

FIGURE 8.32 An actual industry drawing with one view used to describe the part.

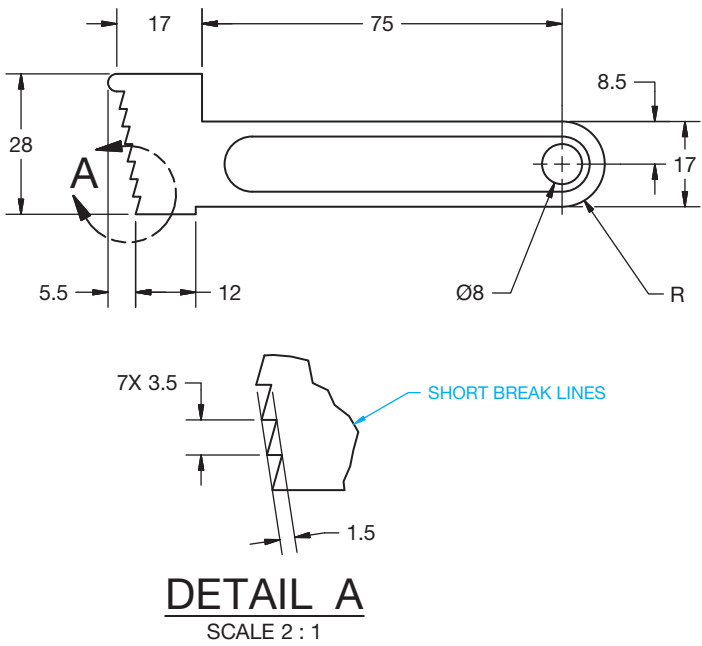


© Cengage Learning 2012

FIGURE 8.33 Partial view. A short break line is used to remove a portion of the top view. This practice should be used with caution and approved by your instructor or supervisor.

### Detail View

A **detail view** can be used when part of a view has detail that cannot be clearly dimensioned due to the drawing scale or complexity. To establish a detail view, a thick phantom line circle is placed around the area to be enlarged. This circle is broken at a convenient location and an identification letter is centered in the break. The height of this letter is generally .24 in. (6 mm) minimum so it stands out from other text. Arrowheads are then placed on the line next to the identification letter, as shown in Figure 8.34. The arrowheads are generally twice the size of dimension-line arrowheads, so they show up better on the drawing. If the dimension-line arrowheads are .125 (3 mm) long on your drawing, then make the viewing plane line arrowheads .25 in. (6 mm) long. A detail view of the area is then placed in any convenient location in the field of the drawing. Detail views are generally enlarged to scales such as 2:1, 4:1, and 10:1.



The view enlargement provides clarity and ease of dimensioning the complex features. The view identification and scale is placed below the enlarged view, such as DETAIL A. The title text height is .24 in. (6 mm). An actual industry drawing with three principal views and a detail view is provided in Figure 8.35.

### Alternate View Placement

It is always best to place entry-level views in the alignment based on the six principal views previously discussed. This helps ensure that the drawing is read based on traditional view-projection methods. However, alternate view placement can be used, if necessary. Using an alternate position for a view is possible when space on the sheet is limited. For example, the rear view can be placed in alignment with and to the right of the right-side view. The right- and left-side views can be placed next to and in alignment with the top view. Even though this possibility is suggested in ASME Y14.3, the practice should be avoided. Any use of this practice should be confirmed with your school or company standards. When sheet space is limited, it is normally best to use a larger sheet if allowed by your school or company.

FIGURE 8.34 Using a detail view. © Cengage Learning 2012

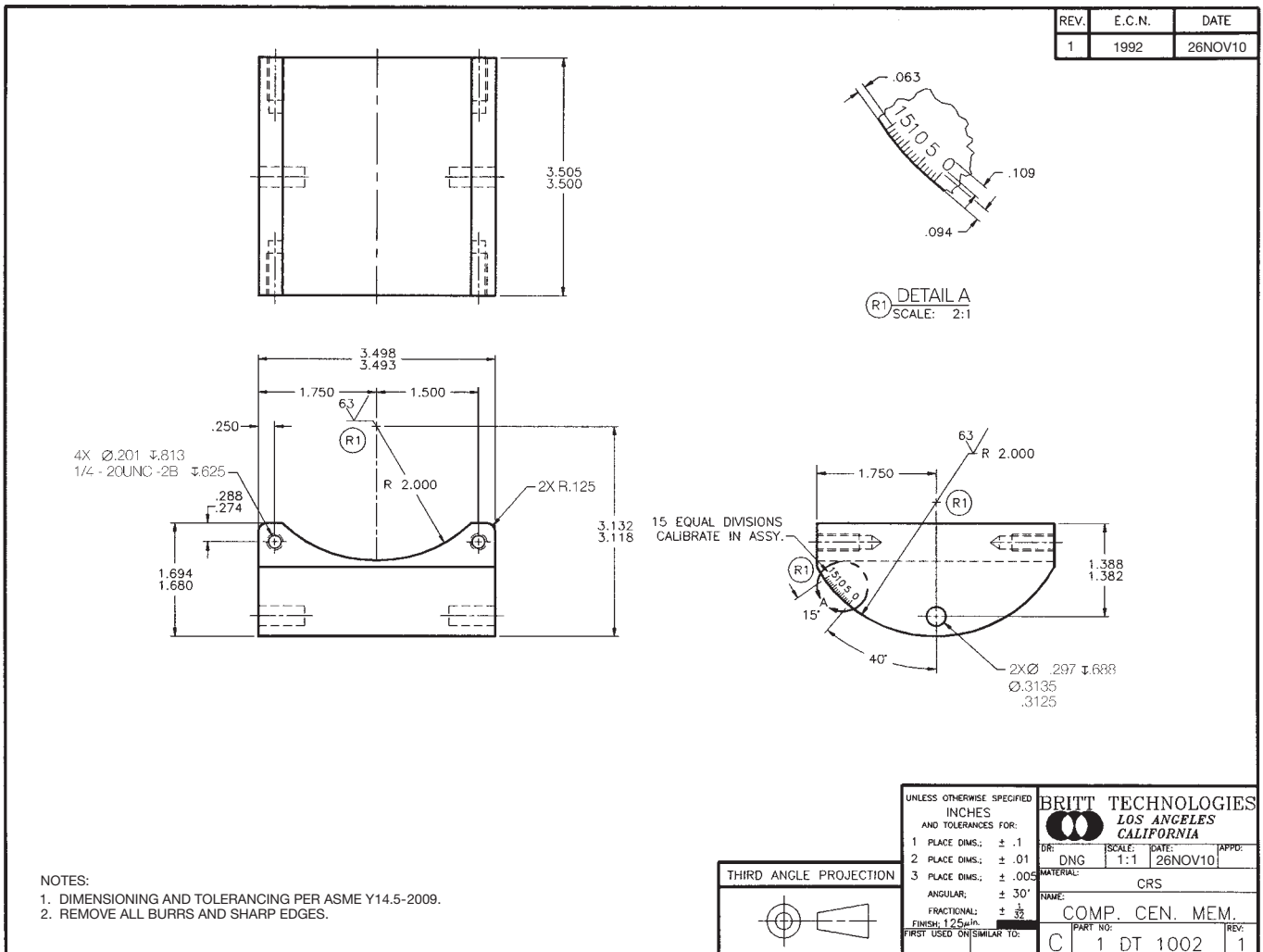


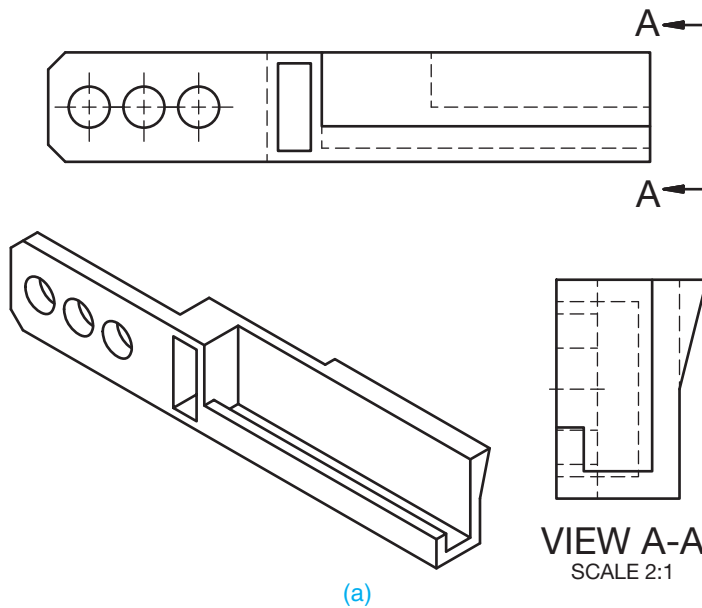
FIGURE 8.35 An actual industry drawing with three principal views and a view enlargement used to describe the part.

## Removed Views

In some cases, it is necessary to place a view out of normal arrangement with the other views. The situations that can make this necessary are when there is limited space on the sheet or when you want to enlarge the view. **Removed views** are established by placing viewing plane lines that identify where the view is taken. Each end of the viewing plane line is labeled with a letter, such as A for the first removed view and B for the second removed view. Consecutive letters are used for additional removed views. The viewing-plane line arrowheads maintain the same 3:1 length-to-width ratio as dimension-line arrowheads. Viewing-plane line arrowheads are generally twice the size of dimension-line arrowheads, so they show up better on the drawing. If the dimension-line arrowheads are .125 (3 mm) long on your drawing, then make the viewing plane line arrowheads .25 in. (6 mm) long. This depends on the size of the drawing and your school or company standards. The view is then moved to a desired location on the drawing, and a title is placed below the view to correspond with its viewing plane line

label, such as VIEW A-A. The title text height is .24 in. (6 mm). The removed view is kept in the same alignment as its normal arrangement. The removed view can be kept at the same scale as the other views or it can be enlarged. When the view is enlarged, the scale is placed under the view title, such as SCALE 2:1. The scale text height is .12 in. (3 mm) (see Figure 8.36a).

It is preferable to keep the removed view on the same sheet from where the view was taken. If a view is placed on a different sheet from where its viewing-plane line is located, then the sheet number and the zone of the cross-reference location are given with the view title, such as SEE SHEET 1 ZONE B4. All sheets of a multiple sheet drawing should be the same size. Each sheet has the same drawing number or part number. The sheets also have page numbers. For example, if there are three sheets, the first sheet is 1/3, the second sheet is 2/3, and the third sheet is 3/3. The format 1 OF 3, 2 OF 3, and 3 OF 3 can also be used. When a drawing has multiple sheets, the first sheet has the complete title block and other sheet blocks, including the angle of projection block and dimensioning and tolerance block. Additional sheets can have the same set of blocks, or



APPROVAL BLOCKS ARE OPTIONAL

COMPANY OR DESIGN ACTIVITY BLOCK IS OPTIONAL

DRAFTER		<b>DELMAR</b> CENGAGE Learning 5 Maxwell Drive Clifton Park, NY 12065-2919				
CHECKER			SIZE	CAGE CODE	DWG NO.	REV
ENGINEER			SCALE			SHEET

REVISION BLOCK IS OPTIONAL

(b)

**FIGURE 8.36** (a) A removed view. (b) The optional continuation title block used after the first sheet when a drawing occupies more than one sheet.

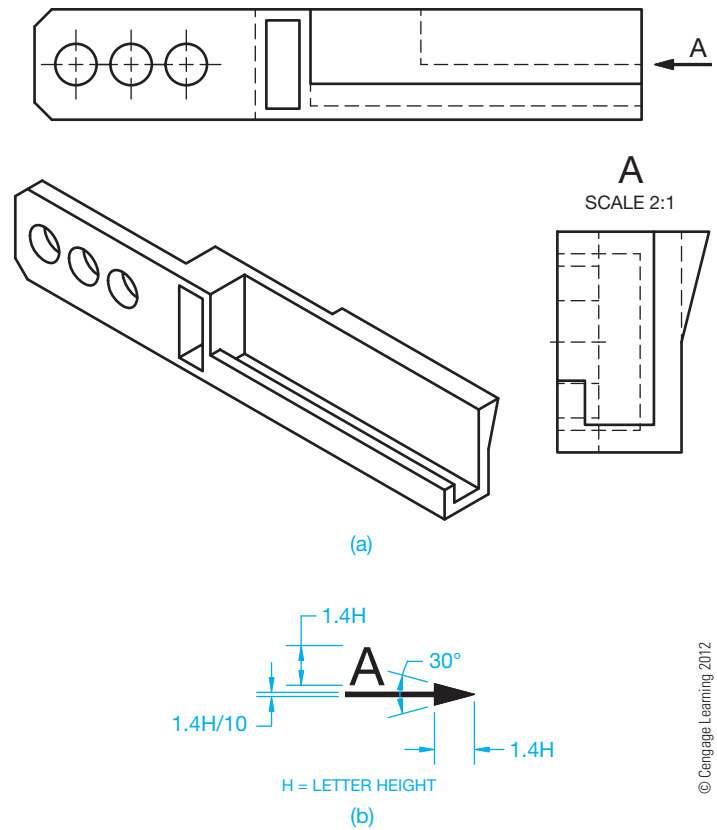
they can have a continuation sheet title block. The continuation sheet title block uses a minimum of the drawing number, scale, sheet size, CAGE code, and sheet number. Figure 8.36b shows a continuous sheet title block. Any use of this practice should be confirmed with your school or company standards.

### Arrow Method for Removed Views

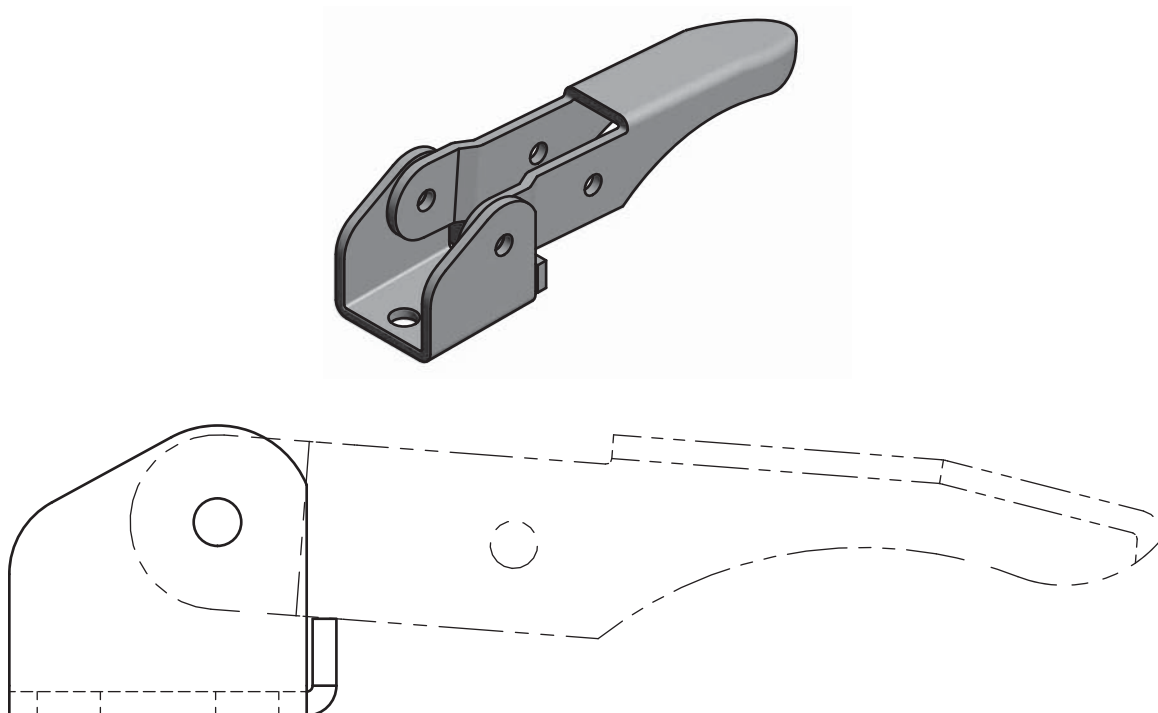
An alternate practice for providing removed views is called the **reference arrow method**. This method was introduced into ASME Y14.3 by the ISO. This technique uses a single reference arrow and view letter pointing to the view where the removed view is taken. The view is then moved to a desired location on the drawing and a title is placed above the view to correspond with its viewing arrow label, such as A. The removed view is kept in the same alignment as its normal arrangement. The removed view can be kept at the same scale as the other views or it can be enlarged. When the view is enlarged, the scale is placed under the view title. Figure 8.37 shows the removed view, reference arrow method, and a detail of the view arrow.

### Views with Related Parts

Normally, a single part in an assembly is drawn alone on one sheet without any portion of the assembly shown. In some applications, it is necessary to show a part or parts that are next to the part being detailed. This is the **related part method**. When this is necessary, the adjacent part is drawn using phantom lines to show its relationship with the part being detailed as shown in Figure 8.38. This practice is usually done when there is a



**FIGURE 8.37** (a) A removed view drawing using the reference arrow method. (b) The view arrow detailed for use on your drawings.



**FIGURE 8.38** Phantom lines used to represent related parts.

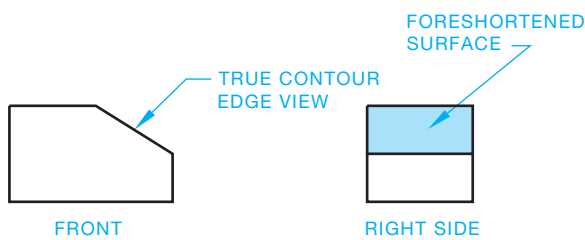
functional relationship between the parts that needs to be specified in a note.

### Rotated Views

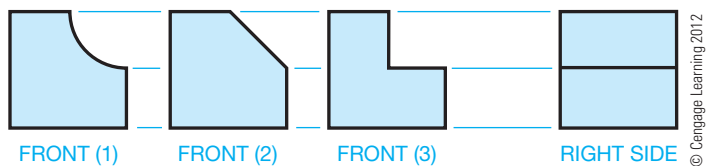
Rotating views from their normal alignment with the six principal views should be avoided, but it is possible if necessary. Situations such as limited sheet space, view size, or an effort to keep all views on one sheet can contribute to this possibility. If this is done, you need to give the angle and direction of rotation under the view title, such as ROTATED 90° CW. CW is the abbreviation for clockwise, and CCW is the abbreviation for counterclockwise. This practice is more appropriate for use with auxiliary views than with the six principal views described in this chapter. Chapter 9 explains auxiliary views and provides additional information about using rotated views. Any use of this practice should be confirmed with your school or company standards. When sheet space is limited, it is normally best to use a larger sheet if allowed by your school or company.

### PROJECTION OF CONTOURS, CIRCLES, AND ARCS

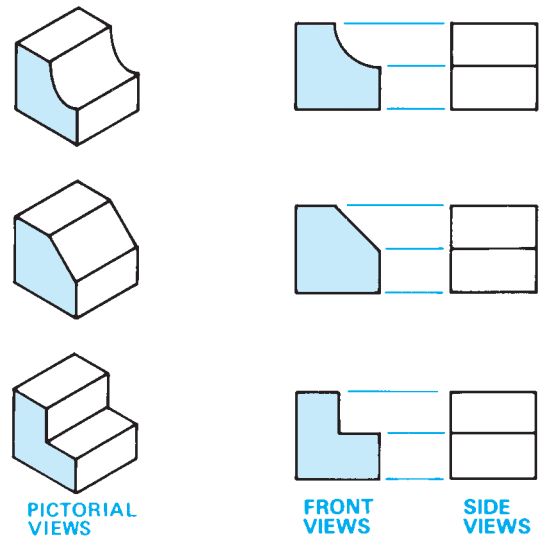
Some views do not clearly identify the shape of certain contours. In these situations, you must draw the adjacent views to visualize the contour. For example, in Figure 8.39 the true contour of the slanted surface is seen as an edge in the front view and shows the surface as an angle. The same surface is foreshortened, slanting away from your line of sight, in the right-side view. It would be impossible to know the true geometry without seeing both views. In Figure 8.40, select the front view that properly describes the given right-side view. All three front views in Figure 8.40 could be correct. The side view does not help the shape description of the front view contour.



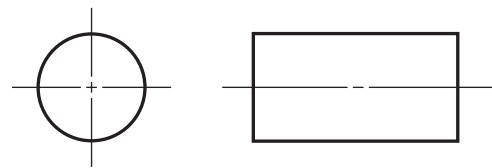
**FIGURE 8.39** Contour representation. The slanted surface is a true edge in the front view and a foreshortened surface in the right-side view.



**FIGURE 8.40** Select the front view that properly goes with the given right-side view. Answer: All three front view options are possible solutions for the given right side view.



**FIGURE 8.41** This shows the importance of a view that clearly shows the contour of a surface.



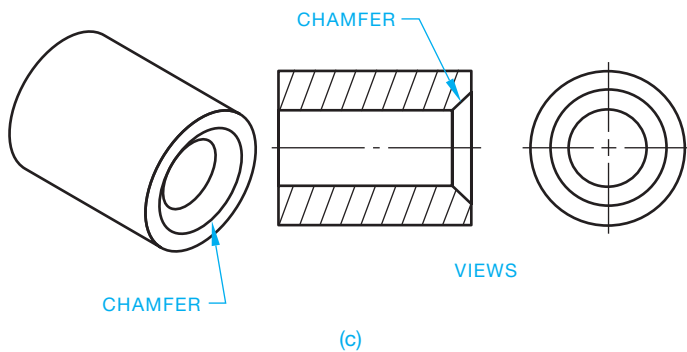
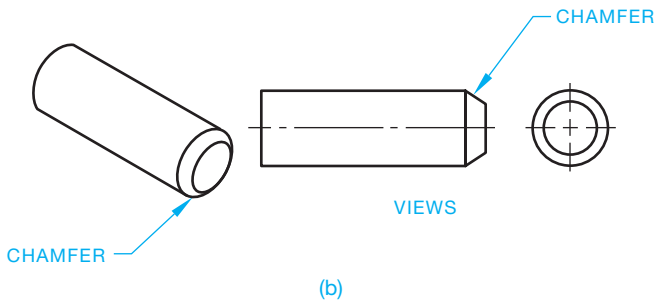
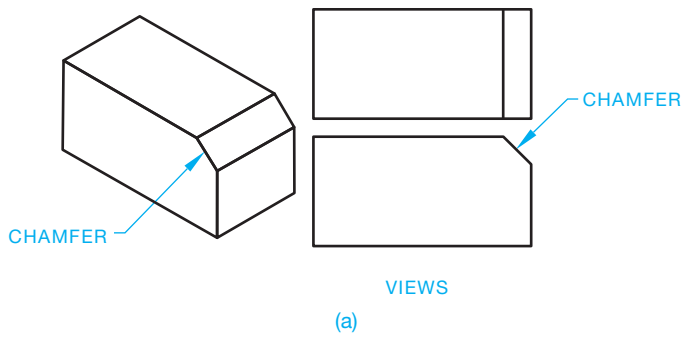
**FIGURE 8.42** Cylindrical shape representation using two views.

Figure 8.41 shows another set of examples that demonstrate the importance of having at least two views to describe the true geometry of the part or object.

Cylindrical shapes appear round in one view and rectangular in another view as seen in Figure 8.42. Both views in Figure 8.42 may be necessary, because one shows the diameter shape and the other shows the length. Dimensioning practices can be used to show the object in Figure 8.42 in one view, but two views are necessary without dimensions. The ability to visualize from one view to the next is a critical skill for a drafter. You may have to train yourself to look at 2-D objects and picture 3-D shapes. You can also use some of the techniques discussed here to visualize features from one view to another.

### Chamfers

A **chamfer** is the cutting away of the sharp external or internal corner of an edge. Chamfers are used as a slight angle to relieve a sharp edge or to assist the entry of a pin or thread into the mating feature. A chamfer is an inclined surface and is shown as a slanted edge or a line, depending on the view. The size and shape of a chamfer is projected onto views. Figure 8.43 shows three examples of chamfered features. Notice how the true contour of the slanted surfaces is seen as edges in the front views, which describe the chamfers as angles. The surfaces shown in the top view of example (a) and the right-side views

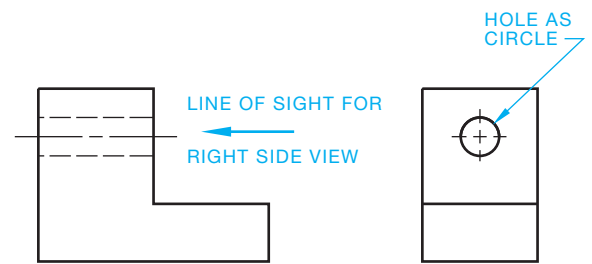


**FIGURE 8.43** Chamfer examples. (a) Outside corner chamfer. (b) Chamfer of an external cylinder. (c) Chamfer on a hole.  
© Cengage Learning 2012

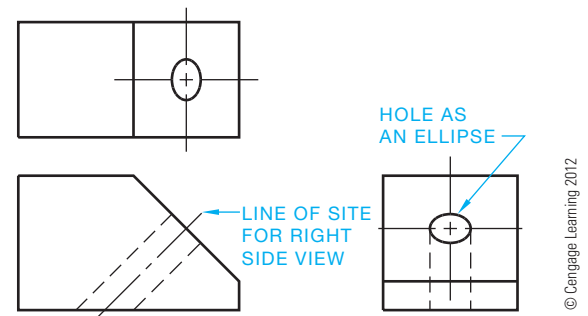
of examples (b) and (c) are foreshortened and slant away from your line of sight.

### Circles on Inclined Planes

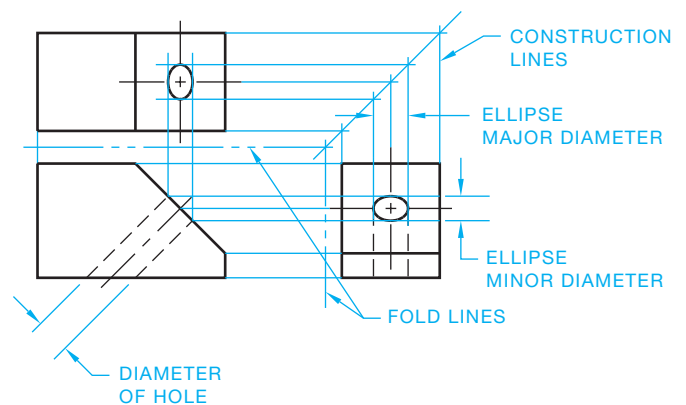
When the line of sight in multiviews is perpendicular to a circular feature such as a hole, the feature appears round as shown in Figure 8.44. When a circle is projected onto an inclined surface, its view is elliptical in shape, as shown in Figure 8.45. The ellipse shown in the top and right-side views of Figure 8.45 is established by projecting the major diameter from the top to the side view and the minor diameter to both views from the front view, as shown in Figure 8.46. The major diameter in this example is the hole diameter. The rectangular areas projected from the two diameters in the top and right-side views of Figure 8.46 provide the boundaries of the ellipse to be drawn in these views. The easiest method of drawing the ellipse is to use a command that allows you to specify the major and minor diameters of the ellipse followed by selecting the center point. The use of CADD makes it easy to draw ellipses with object or hidden line styles.



**FIGURE 8.44** View of a hole projected as a circle and its hidden view through the part.  
© Cengage Learning 2012



**FIGURE 8.45** Hole projected from an inclined surface is represented as an ellipse in the adjacent view.  
© Cengage Learning 2012



**FIGURE 8.46** Establish an ellipse in the inclined surface.  
© Cengage Learning 2012

### Arcs on Inclined Planes

When a curved surface from an inclined plane must be drawn in multiview, a series of points on the curve establishes the contour. Begin by selecting a series of points on the curved contour as shown in the right-side view of Figure 8.47. Project these points from the right side to the inclined front view. From the point of intersection on the inclined surface in the front view, project lines to the top view. Then project corresponding points from the right side to the 45° projection line and onto the top view. Corresponding lines create a pattern of points, as shown in the top view in Figure 8.47. After the series of points is located in relationship to the front and top views, connect the points with an

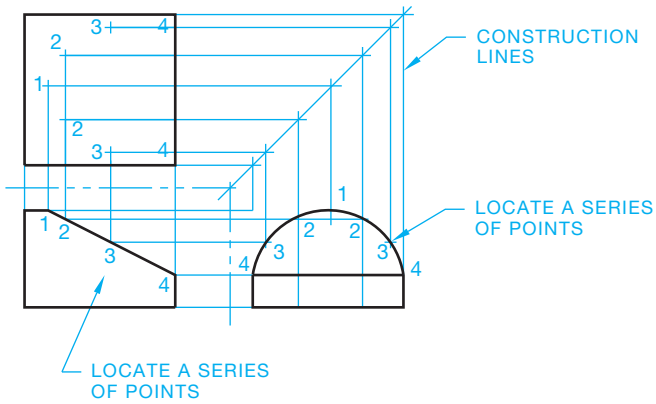


FIGURE 8.47 Locating an inclined curve in multiview.

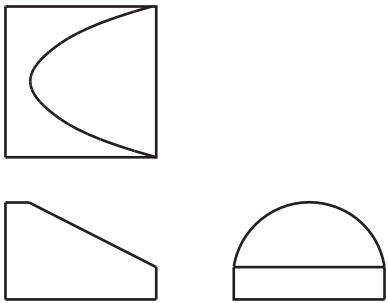


FIGURE 8.48 Completed curve.

appropriate command such as SPLINE. See the completed curve in Figure 8.48. Use a construction layer to draw the projection lines. This layer can be turned off or frozen when finished.

## Fillets and Rounds

**Fillets** are slightly rounded inside curves at corners, generally used to ease the machining of inside corners or to allow patterns to release more easily from castings and forgings. Fillets can also be designed into a part to allow additional material on inside corners for stress relief (see Figure 8.49).

Other than the concern of stress factors on parts, certain casting methods require that inside corners have fillets. The size of the fillet often depends on the precision of the casting method. For example, very precise casting methods can have smaller fillets than green-sand casting, where the exactness of the pattern requires large inside corners. Fillets are also common on machined parts, because it is difficult to make sharp inside corners.

**Rounds** are rounded outside corners that are used to relieve sharp exterior edges. Rounds are also necessary in the casting and forging process for the same reasons as fillets. Figure 8.50 shows rounds represented in views.

A machined edge causes sharp corners, which can be desired in some situations. However, if these sharp corners are to be rounded, the extent of roundness depends on the function of the part. When a sharp corner has only a slight relief, it is referred to as a **break corner**, as shown in Figure 8.51.

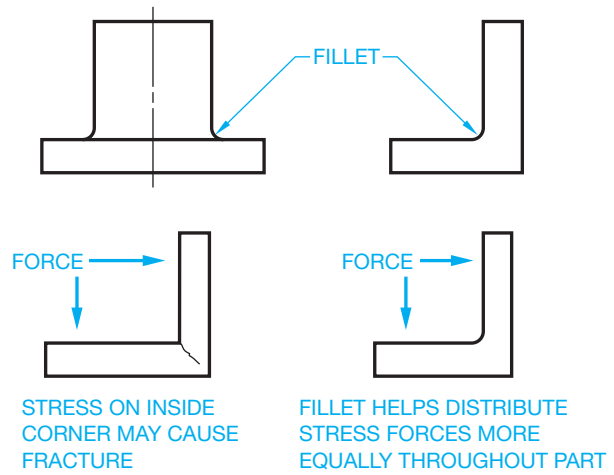


FIGURE 8.49 Fillets.

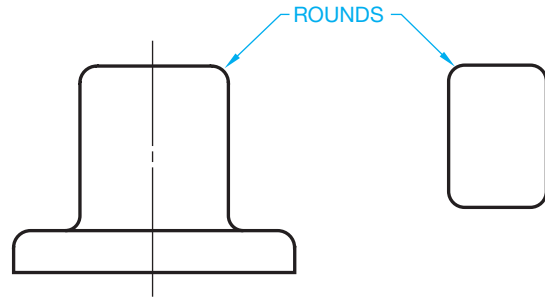


FIGURE 8.50 Rounds.

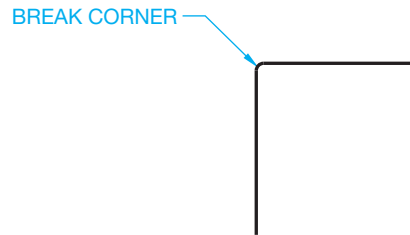


FIGURE 8.51 Break corner.

## Rounded Corners in Multiview

An outside or inside slightly rounded corner of an object is represented in multiview as a contour only. The extent of the round or fillet is not projected into the view as shown in Figure 8.52. Cylindrical shapes can be represented with a front and top view, where the front identifies the height and the top shows the diameter. Figure 8.53 shows how these cylindrical shapes are represented in multiview. Figure 8.54 shows the representation of the contour of an object as typically displayed in multiview using phantom lines. This is done to accent the rounded feature.

## Runouts

The intersections of features with circular objects are projected in multiview to the extent where one shape runs into the other.

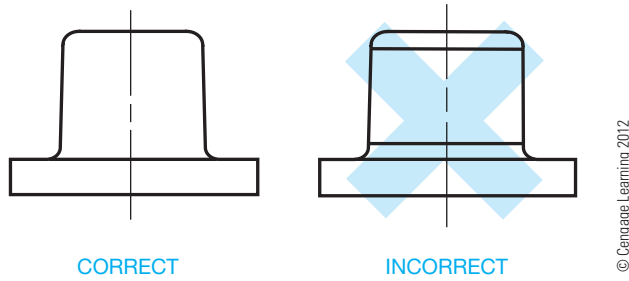


FIGURE 8.52 Rounds and fillets in multiview.

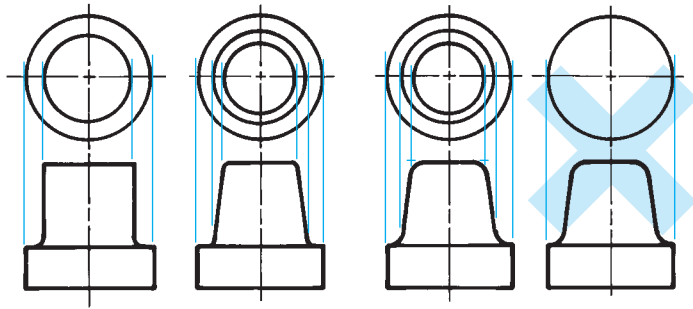


FIGURE 8.53 Rounded curves and cylindrical shape in multiview.  
© Cengage Learning 2012

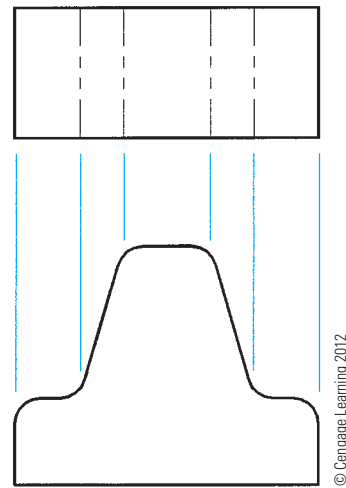


FIGURE 8.54 Contour in multiview.

The characteristics of the intersecting features are known as **runouts**. The runout of features intersecting cylindrical shapes is projected from the point of tangency of the intersecting feature, as shown in Figure 8.55. Notice also that the shape of the runout varies when drawn at the cylinder, depending on the

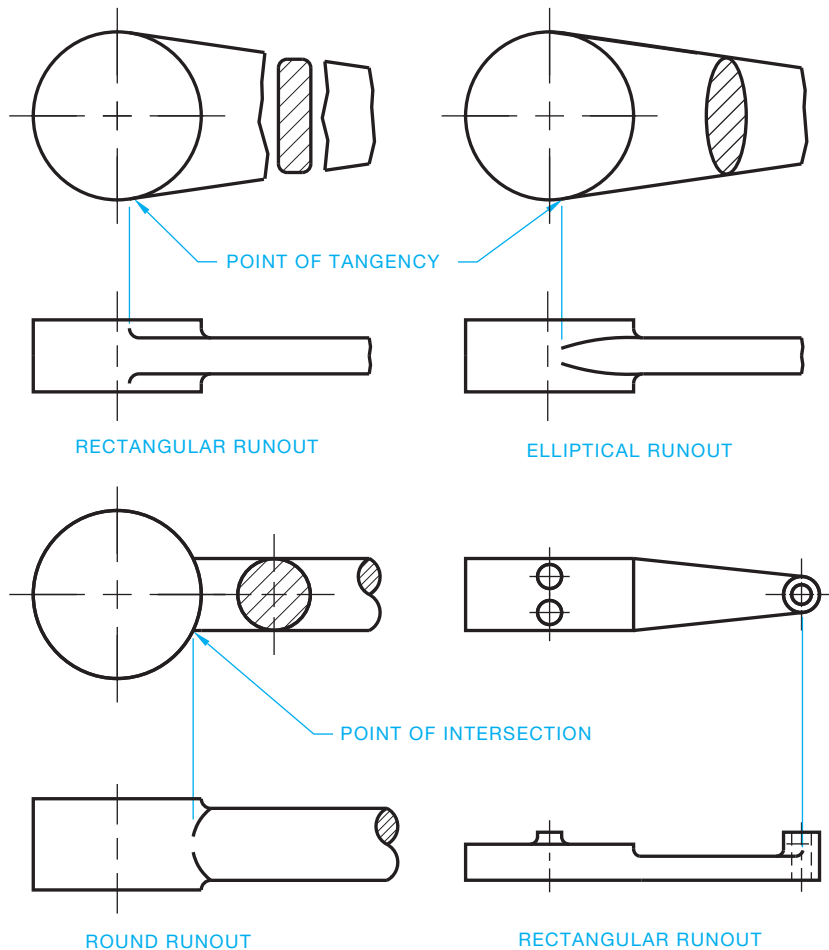


FIGURE 8.55 Establishing projections for runouts.



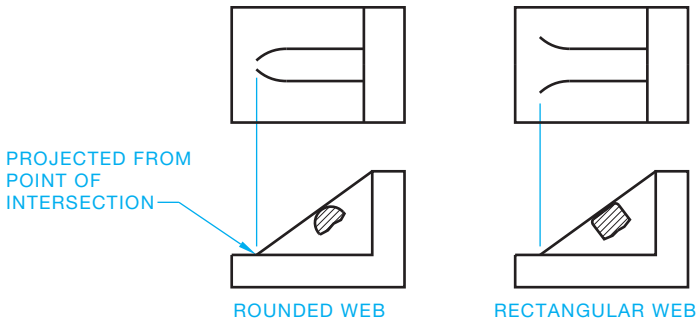


FIGURE 8.56 Projecting the runouts of a web. © Cengage Learning 2012

shape of the intersecting feature. Rectangular-shaped features have a fillet at the runout, whereas curved (elliptical or round) features contour toward the centerline at the runout. Runouts also exist when a feature such as a web with rounds intersects another feature, as shown in Figure 8.56.

### LINE PRECEDENCE

When drawing multiviews, it is common for one type of line to fall in the same place as a different line type. As a drafter, you need to decide which line to draw and which line to omit. This is known as **line precedence**. You draw the line that is most important based on the following rules and as shown in Figure 8.57:

- Object lines take precedence over hidden lines and centerlines.
- Hidden lines take precedence over centerlines.
- In sectioning (covered in Chapter 12), cutting-plane lines take precedence over centerlines.

When an object line is drawn over a centerline, the ends or tails of the centerline are drawn slightly beyond the outside of the view or feature. Use a uniform distance, such as .125 in. (3 mm) or .25 in. (6 mm), past an object. The distance the centerline goes past the object depends on the size of the drawing and company

standards. The uniform distance past an object is maintained unless a longer distance is needed for dimensioning purposes.

When a centerline is used to establish a dimension, the centerline continues as an extension line without a gap where the centerline ends and the extension line begins. This is discussed in detail in Chapter 10. Centerlines do not extend between views of the drawing except as discussed with auxiliary views in Chapter 9. Figure 8.57 shows examples of line precedence.

### MULTIVIEW ANALYSIS AND REVIEW

The following is a review covering the features and importance of using multiviews and orthographic projection.

- The multiview system of orthographic projection is covered in the ASME Y14.3 standard.
- The two internationally accepted view projection systems are third-angle and first-angle projection. Both systems are discussed in this chapter, and third-angle projection is used throughout this textbook.
- Multiview drawings represent the shape of an object using two or more views; however, one view can be used when a third dimension such as depth, thickness, or diameter can be given in a note or as a dimension on the object.
- There are six principal views: front, top, right side, left side, bottom, and rear.
- All views are aligned in either third-angle projection or first-angle projection, and the appropriate third- or first-angle projection symbol should be placed on the drawing.
- Adjacent views must be aligned unless otherwise specified. **Adjacent views** are two adjoining views aligned by projection.
- Related views must be aligned unless otherwise specified. **Related views** are two views adjacent to the same intermediate view.
- There is always one dimension that is the same between views.

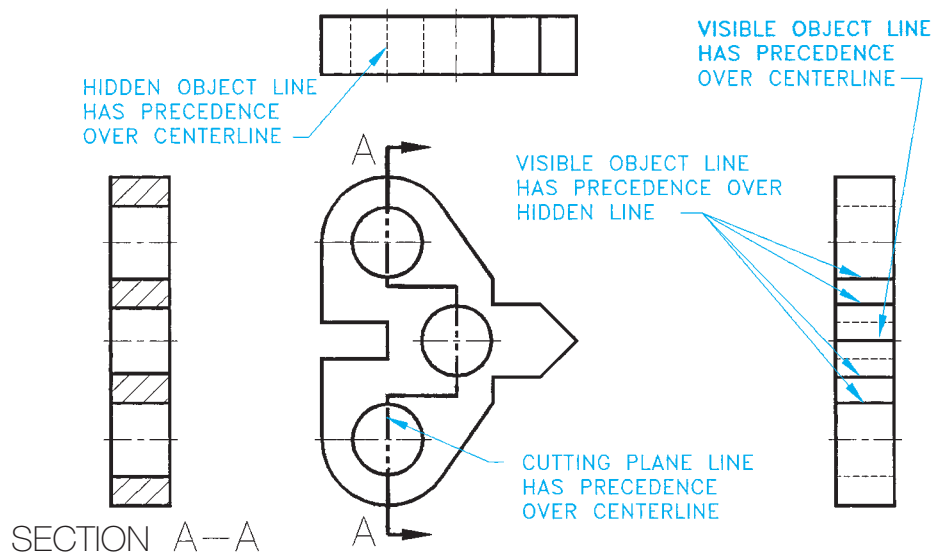


FIGURE 8.57 Line precedence.

© Cengage Learning 2012

- The front view is normally considered the most important view from which other views are established. Specific view selection guidelines are provided in this chapter.
- The number of required views can vary, depending on the complexity of the object and must be selected to describe the shape of the object and features on the object completely.
- A line in a view is in true length when the line is parallel to the projection plane.
- A surface of a view is in true size and shape when the surface is parallel to the projection plane.
- A line in a view is foreshortened when the line is not parallel to the projection plane.
- A surface of a view is foreshortened when the surface is not parallel to the projection plane.
- Additional view-placement options are discussed in this chapter and include removed views, rotated views, and detail views. Use of these options should be carefully confirmed with your school or company practices.

## RECOMMENDED REVIEW

It is recommended that you review the following parts of Chapter 6, *Lines and Lettering*, before you begin working on multiview drawings. This will refresh your memory about how related lines are properly drawn.

- Object lines.
- Viewing and cutting planes.

- Hidden lines.
- Break lines.
- Centerlines.
- Phantom lines.

## Descriptive Geometry

**Descriptive geometry** is a drafting method used to study 3-D geometry with 2-D drafting applications where planes of projections analyze and describe the true geometric characteristics.



### Descriptive Geometry

For complete information about Descriptive Geometry, go to the Student CD, select **Reference Material**, and then **Descriptive Geometry I** and **Descriptive Geometry II**.

## MULTIVIEW LAYOUT

Many factors influence the drawing layout. Your prime goal should be a clear and easy-to-read drawing with selected views and related information. Although this chapter deals with multiview presentation, it is not very realistic to consider view layout without thinking about the effects of dimension placement on the total drawing. Chapter 10, *Dimensioning and Tolerancing*, correlates the multiview drawings of **shape description** with dimensioning, known as **size description**.

## MULTIVIEW CONSTRUCTION

Most CADD programs contain a variety of tools and options that allow you to develop multiview drawings efficiently and accurately. Construct a multiview drawing using a variety of techniques, depending on the objects needed, personal working preference, and whatever you know about the size and shape of objects. Often a combination of construction methods and CADD tools prove most effective to produce multiviews. Most 2-D drafting applications include functions for accurately defining object points using coordinate point entry methods and basic drawing aids such as grid lines and grid snaps. You can also develop multiviews using common construction geometry or specific software drawing aids such as AutoCAD's object snap and AutoTrack tools.

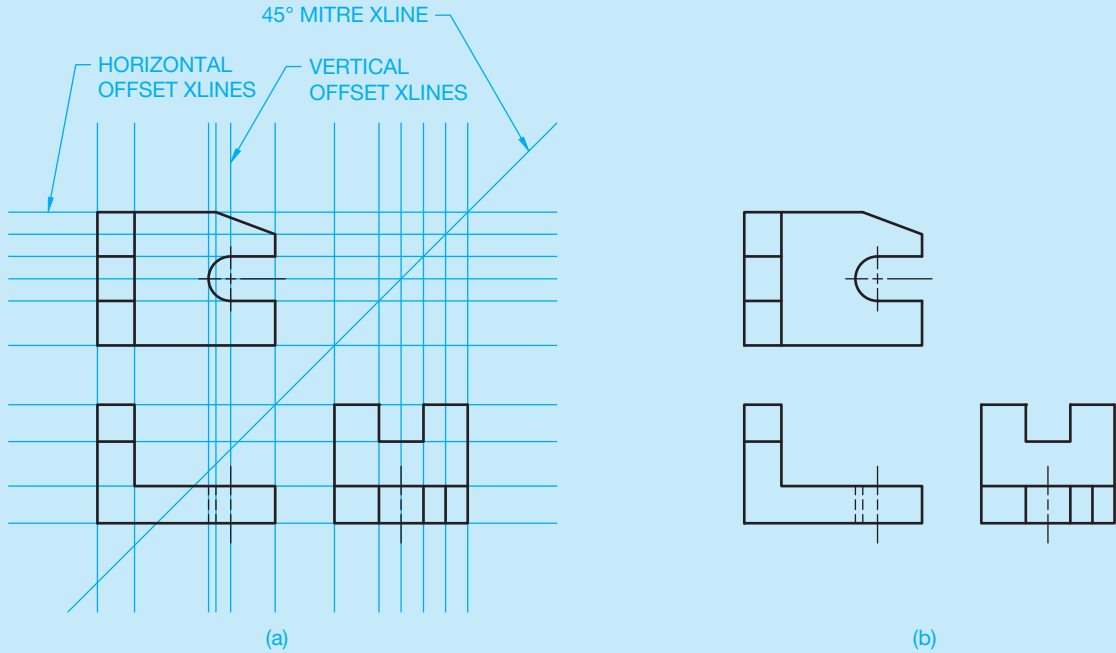
### Construction Lines

Construction lines are widely used in CADD for layout work. Objects intended for construction purposes are usually drawn using a unique layer named Construction, for

example, and assigned a specific color. You can draw construction lines using basic drafting commands such as LINE, CIRCLE, and ARC, but there are also specific tools that improve the usefulness of construction lines. One example is AutoCAD's Construction Line, or XLINE, command. The XLINE command allows you to create construction lines of infinite length horizontally, vertically, at an angle, or offset from an existing line or to bisect an angle.

Figure 8.58a shows an example of using construction lines to form three views. Use the Intersection object snap mode to select the intersecting *xlines* when drawing line and arc end points and the center point of the arc. An *xline* is a construction line in AutoCAD that is infinite in both directions; it is often helpful for creating accurate geometry and multiviews. Notice that a single, infinitely long *xline* can provide construction geometry for multiple views. When you finish using construction geometry, such as when you finalize the multiview layout, freeze or turn off the Construction layer, or use a DELETE or ERASE command to remove construction objects (see Figure 8.58b).

(Continued)

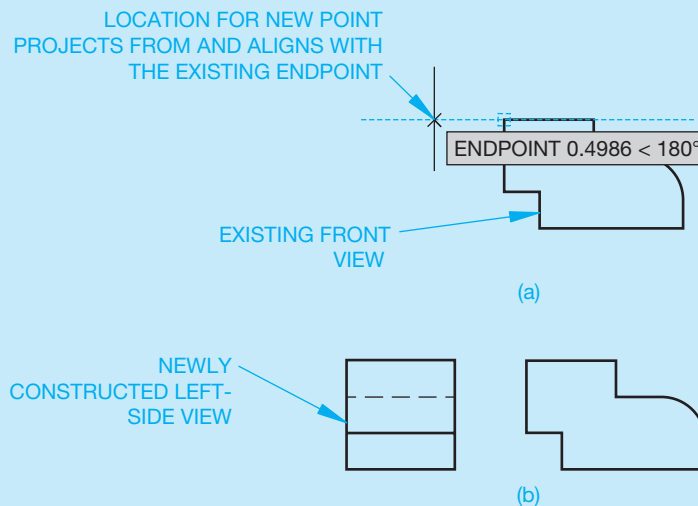


**FIGURE 8.58** (a) Using a complete grid of construction lines to form a multiview drawing by locating points at the intersections of the construction lines. (b) The multiview drawing with the Construction layer turned off.

### Drawing Aids

Figure 8.59 shows an example of using AutoCAD object snap tracking and a running Endpoint object snap mode to locate points for a left-side view by referencing points on the existing front view. Notice that the AutoTrack alignment path in Figure 8.59a provides a temporary

construction line. AutoCAD polar tracking vectors offer a similar type of temporary construction line. Tools like object snap and polar tracking mimic accurate construction lines without the need to spend time drawing additional objects. Figure 8.59b shows the complete front and left-side views.



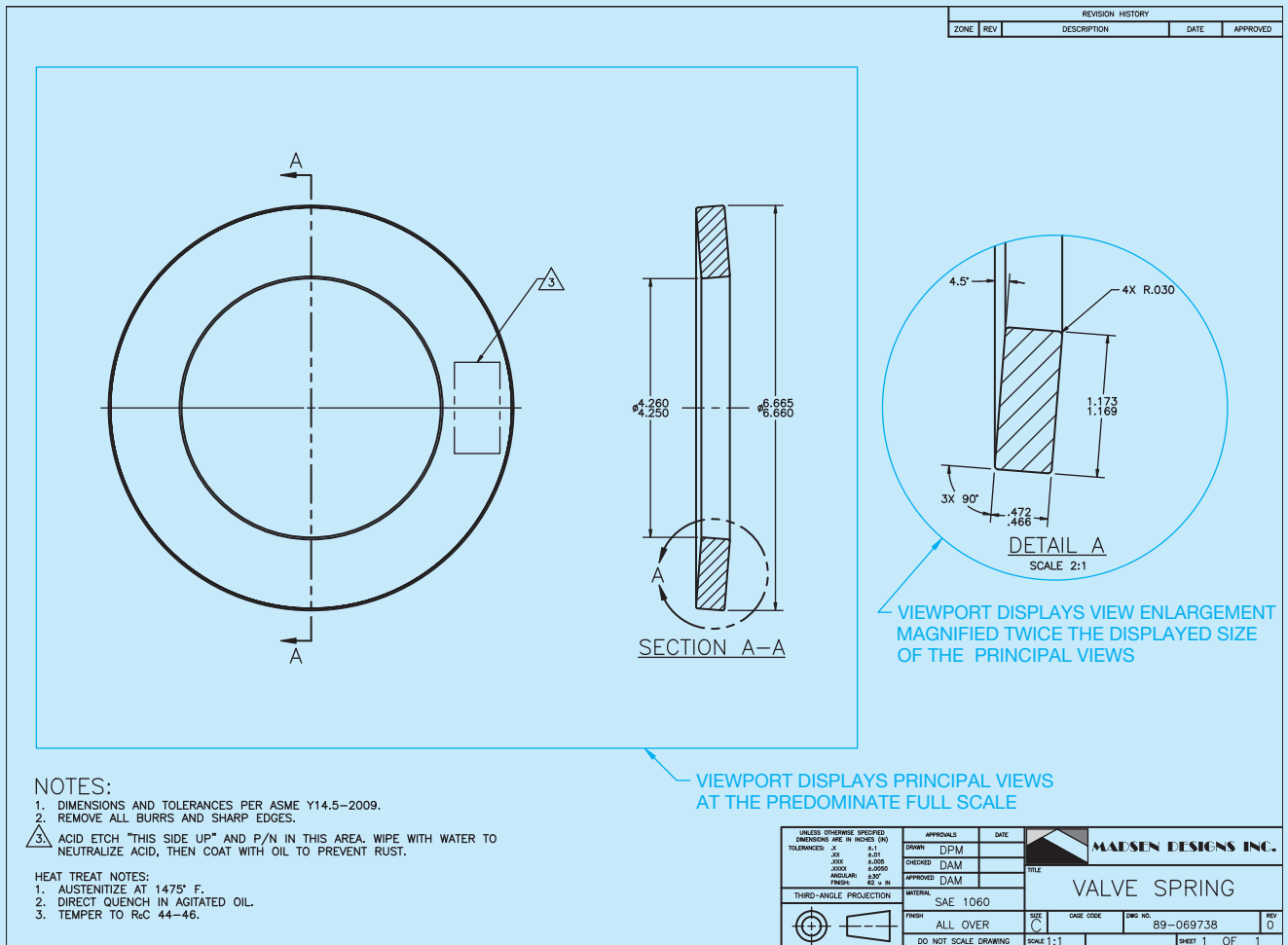
**FIGURE 8.59** A basic example of using object snap tracking to create an additional view. (a) Referencing points from the front view to establish the first line of the left-side view. (b) The completed front and left-side views.

(Continued)

### VIEW ENLARGEMENT

CADD software greatly improves your ability to create precise view enlargements or details. There are several possible techniques for creating enlarged views, depending on the CADD system. A basic approach is to use combinations of general editing commands, such as COPY and SCALE, to copy existing geometry to a new location and enlarge the items to any size. An often more effective method is to redisplay a portion of an existing view at a specific magnification, or zoom factor, without copying

and changing the physical size of objects. One example of this process involves the use of AutoCAD's Model Space and Paper Space (Layout). With this example, you increase the displayed size of a portion of an existing view using a scaled viewport (see Figure 8.60). Working with drawing display options is an advantage because you do not have to copy and enlarge or otherwise re-create a view. Instead, you just show a portion of the view using different display characteristics.



**FIGURE 8.60** An example of a multiview part drawing with a view enlargement created using AutoCAD floating viewports in Paper Space (Layout). Courtesy Madsen Designs Inc.

## MULTIVIEW PROJECTION

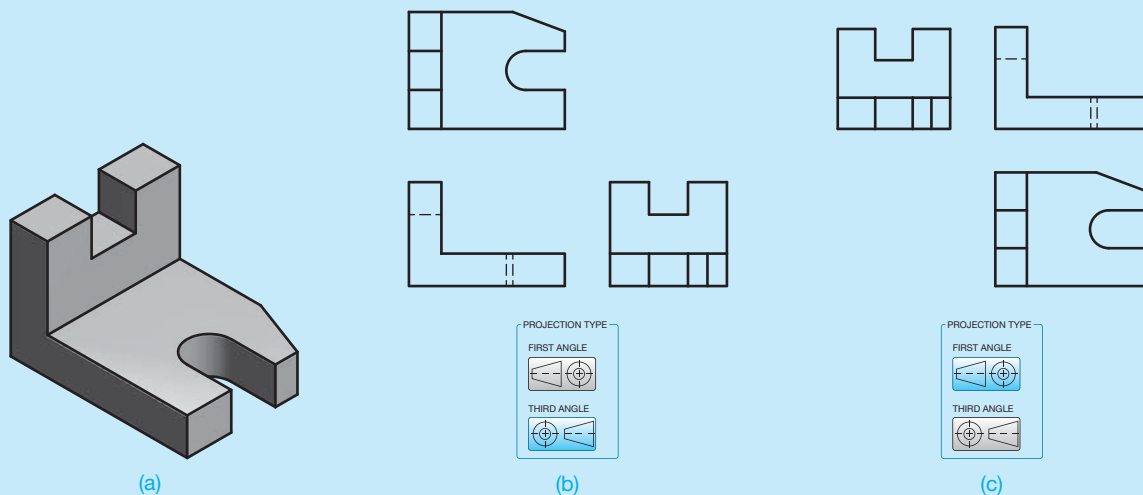
You can extract 2-D views from an existing 3-D model to create a multiview drawing. This approach is different from the traditional techniques of constructing multiviews, but it still follows the same multiview theory and format. A basic process is to rotate the display of the model to show orthographic views, similar to the concept of unfolding the glass box. Multiple windows or viewports, each showing a unique orthographic projection, allow you to create a multiview layout from the model. Some CADD software, primary those programs that combine 3-D solid modeling with parametric 2-D drawing capabilities, provide tools that significantly improve the basic concept of extracting multiviews from a model. Drafters new to 3-D modeling and the 2-D drawing capabilities of some modeling programs are often amazed by the speed at which entire multiview drawings can be created from an existing part or assembly model.

Preparing a multiview drawing using 3-D modeling software with 2-D drawing capabilities begins with creating the model, usually in a separate part or assembly file (see Figure 8.61a). The next step is to enter the drawing environment to extract views from the model using drawing tools. Use a tool such as BASE VIEW or MODEL VIEW to select the model from which to reference views, specify view settings, and place views. For example, assuming the model is accurate and you want to create a front view, select FRONT from a menu, specify the scale and other view characteristics, and pick a location for the view on the sheet. Now use other view tools to project additional views from the initial view as needed (see Figure 8.61).

## Angle of Projection and Other View Settings

You must select the appropriate angle of projection and other view settings when extracting multiviews from a solid model. Figure 8.61b shows three views of a model created using third-angle projection. Figure 8.61c shows views created using first-angle projection. What you cannot see in Figure 8.61 is the mere seconds it took to create the multiviews from the existing model. Some CADD systems offer predefined view layouts that allow you to create a specific arrangement of multiviews in a single operation. You can use tools like Autodesk Inventor SHEET FORMAT or SolidWorks STANDARD 3 VIEW to create the required number of views from a model instantly.

The file you use to create multiviews from a model includes all settings and preferences, such as angle of projection, view alignment and scale, object display style, and line conventions. For example, when you select the third-angle projection setting shown in Figure 8.61b, the system automatically applies third-angle projection when you project views. The system also maintains correct alignment and settings between views. However, you are still responsible for determining the appropriate views and multiview layout. The parametric nature of solid modeling programs ensures that when you edit a model, the corresponding drawing updates to reflect the new design. Similarly, you can change a model by modifying the parametric model dimensions inside the 2-D drawing.



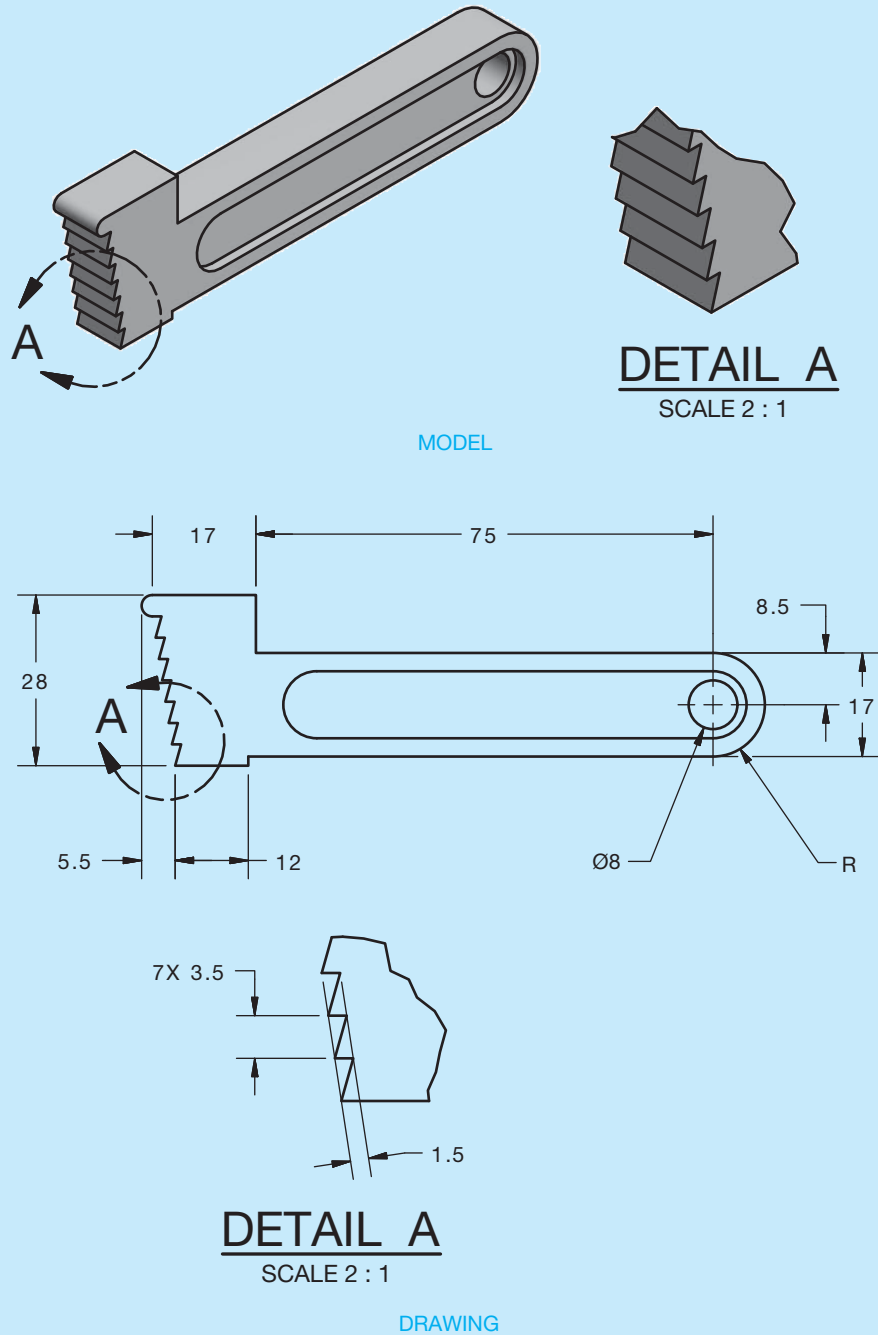
**FIGURE 8.61** (a) The solid model provides all of the geometry needed to prepare a multiview drawing. (b) Using a separate drawing file and third-angle projection to extract multiviews. (c) Using a separate drawing file and first-angle projection to extract multiviews.

(Continued)

### VIEW ENLARGEMENT

Some 3-D modeling software with 2-D drawing capabilities provide tools that make preparing accurate alternate views, such as view enlargements, fast and easy. Tools such as DETAIL VIEW allow you to create a view enlargement by referencing an existing drawing view, which parametrically associates a view with the model (see Figure 8.62).

Using tools like DETAIL VIEW typically involves drawing a circle or other shape around a specific feature on an existing drawing view, such as the front view shown in Figure 8.62. You then specify view preferences, such as scale and title, and pick a location for the view on the sheet. Depending on the drawing settings, the required phantom line circle, arrowheads, identification letter, and view title automatically add to the drawing.



**FIGURE 8.62** Tools such as DETAIL VIEW allow you to create a view enlargement by referencing an existing drawing view, which parametrically associates all views with the model.

© Cengage Learning 2012



**NOTE:** The following information provides very detailed steps and instructions for drawing layout. These steps were critical in the past when using manual drafting. Manual drafting requires you to determine specific views, dimension locations, drawing scale, and sheet size before starting to draw. Once you begin manual drafting, the only way to change your strategy is to erase or start over. This is not the case with CADD, although it is still important to do preliminary planning when using CADD.

Careful planning is especially useful as a student or entry-level drafter. Careful planning normally saves you time and frustration. The following steps can help you learn to think about all of the items that go into creating a drawing, including number of views, view placement, view spacing, space needed for dimensions and notes, drawing scale, and the sheet sized needed for a clear and easy-to-read final drawing. The advantage to CADD is that it is easy and accurate to fix mistakes and add content to a drawing. When using CADD, you can move views as desired, change the drawing scale or sheet size at any time, and you can add a view or detail without much difficulty. Nevertheless, before you become an experienced drafter, it is best to start out by following the logical sequence of steps described in this chapter.

## Sketching the Layout

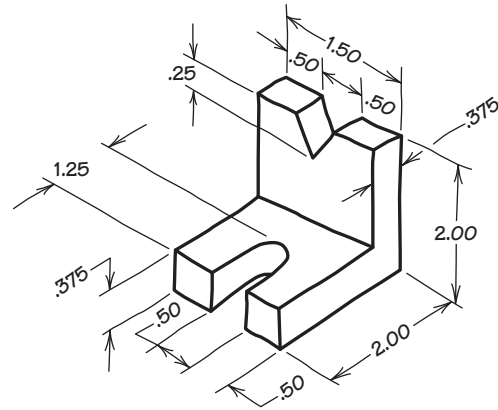
The initial steps in view layout should be performed using rough sketches. By using rough sketches, you can analyze which views you need before you begin formal drafting. Sketches do not have to be perfect. Try to sketch as quickly as you can to save time. Consider the engineering sketch in Figure 8.63 as you evaluate the proper view layout.

**STEP 1** Select the front view using the rules discussed in this chapter. Sketch your selected front view. Try to keep your sketch proportional to the actual object, as in Figure 8.64. However, keep in mind that a sketch does not have to be perfect. It should be done quickly to save time while helping you lay out the drawing.

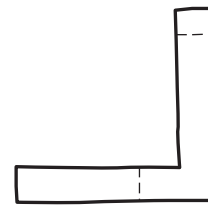
**STEP 2** Select the other views needed to describe the shape of the V-BLOCK MOUNT completely, as shown in Figure 8.65.

The front, top, and left-side views clearly define the shape of the V-BLOCK MOUNT. Now lay out the formal drawing using the sketch as a guide. Several factors must be considered before you begin:

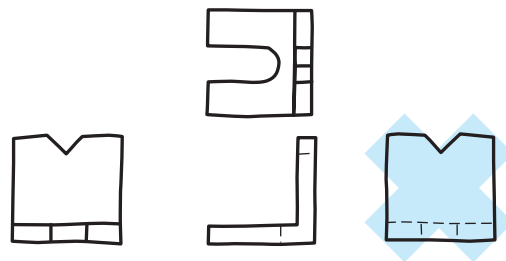
1. Size of drawing sheet.
2. Scale of the drawing.
3. Number and size of views.
4. Amount of blank space required for notes and future revisions.
5. Dimensions and notes (not drawn at this time).



**FIGURE 8.63** Create a multiview drawing from the given engineering sketch.



**FIGURE 8.64** Sketch the front view.

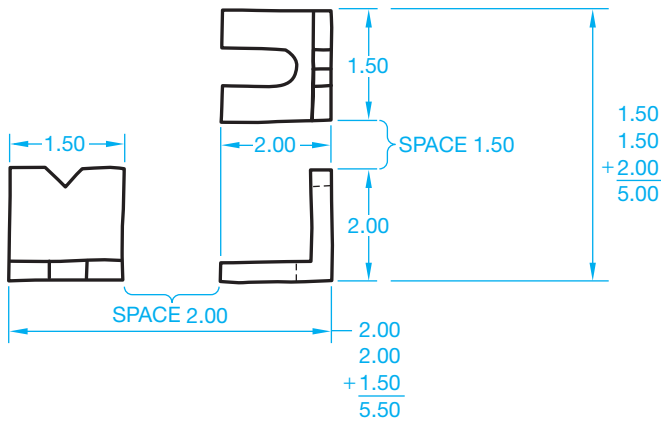


**FIGURE 8.65** Sketch the required views.

## Drawing the Layout

**STEP 1** The recommended drawing area is determined by the sketch and calculations shown in Figure 8.66. In the example of the V-BLOCK MOUNT in Figure 8.66, there are three views, with the overall dimension of each view shown, and there is an estimated spaced provided between views. Use your rough sketch as a guide to establish the actual size of the drawing by adding the overall dimensions and the space between views. The overall drawing area is calculated to be 5.5 × 5 in. (250 × 150 mm). The amount of space selected between views should not crowd the views. The actual space between views is determined by the dimensions placed between the views. Keep in mind that you do not need to consider actual dimensions when evaluating space requirements at this time. The effect of dimensions on drawing layouts is discussed in Chapter 10.

**STEP 2** After determining the approximate drawing area in Figure 8.66, determine the working area so you can establish the desired sheet size. The working area is the space available on the sheet for you to place the drawing. The



© Cengage Learning 2012

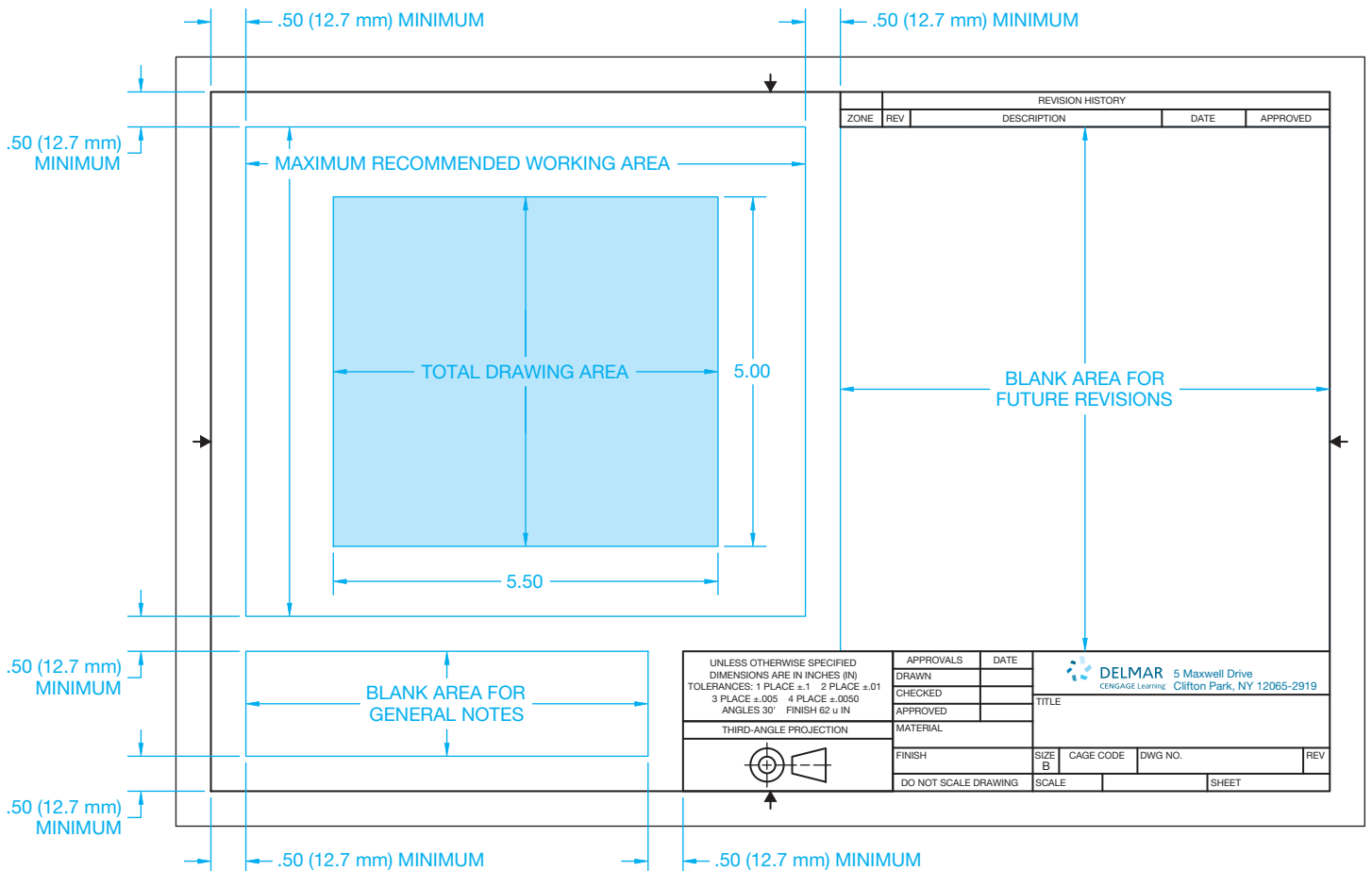
**FIGURE 8.66** Rough sketch with overall dimensions and selected space between views to determine the estimated drawing area.

amount of blank area on a drawing depends on company standards. Some companies want the drawing to be easy to read and with no crowding. Other companies may want as much information as possible on the smallest sheet. Generally, .50 in. (12.7 mm) should be the minimum space between the drawing and borderlines, sheet blocks, and general notes. More space is preferred. An area for future revision should be left between the title block and upper right corner of the

sheet. An area for general notes should be available to the left of the title block for ASME standard layout or in the upper left corner for military (MIL) standard layout. The remaining area is the working area, which is the space available for drawing. The working area of a B-size (11 × 17 in.) or A3-size (297 × 420 mm) drawing sheet provides enough space for the desired drawing area. Figure 8.67 shows the proposed drawing area inside of the working area of a B-size drawing sheet.

**STEP 3** Within the working area and drawing area established, use construction lines to block out the views that you selected in the rough sketch. Use multiview projection as discussed in this chapter, beginning with the front view (see Figure 8.68). Place your construction lines on a unique layer that can be turned off or frozen when no longer needed.

**STEP 4** Complete your drawing by using proper ASME line types and line thicknesses. Each line type should be on its own layer. The general notes can be entered in the lower left corner of the drawing by providing a .50 in. (12.7 mm) space from the border line. Placing notes is optional at this time but will be required after you learn about dimensioning practices. Confirm with your instructor if notes should be added now. Figure 8.69 shows the completed drawing.



**FIGURE 8.67** The recommended drawing area inside the available working area. © Cengage Learning 2012



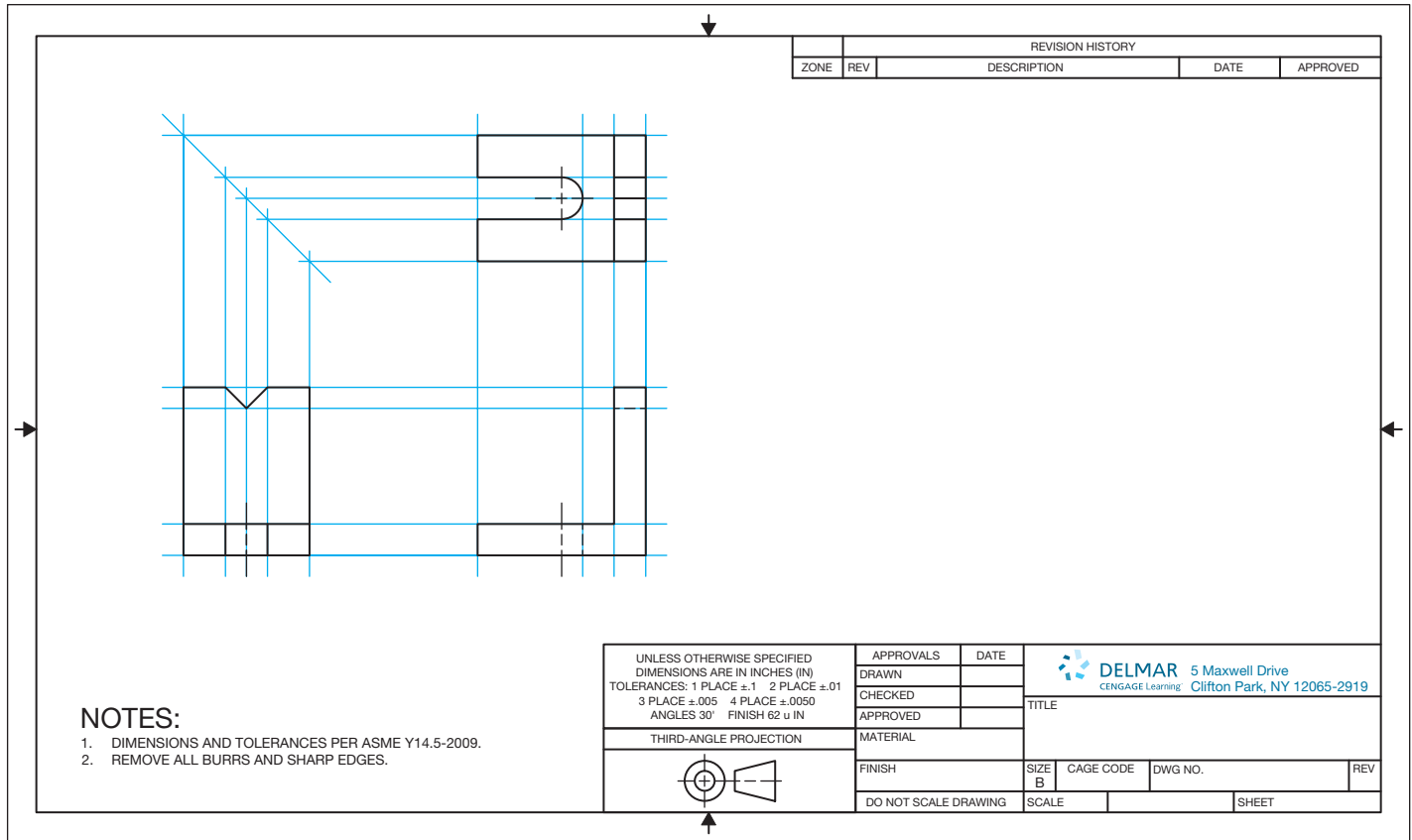


FIGURE 8.68 Lay out the views using construction lines. © Cengage Learning 2012

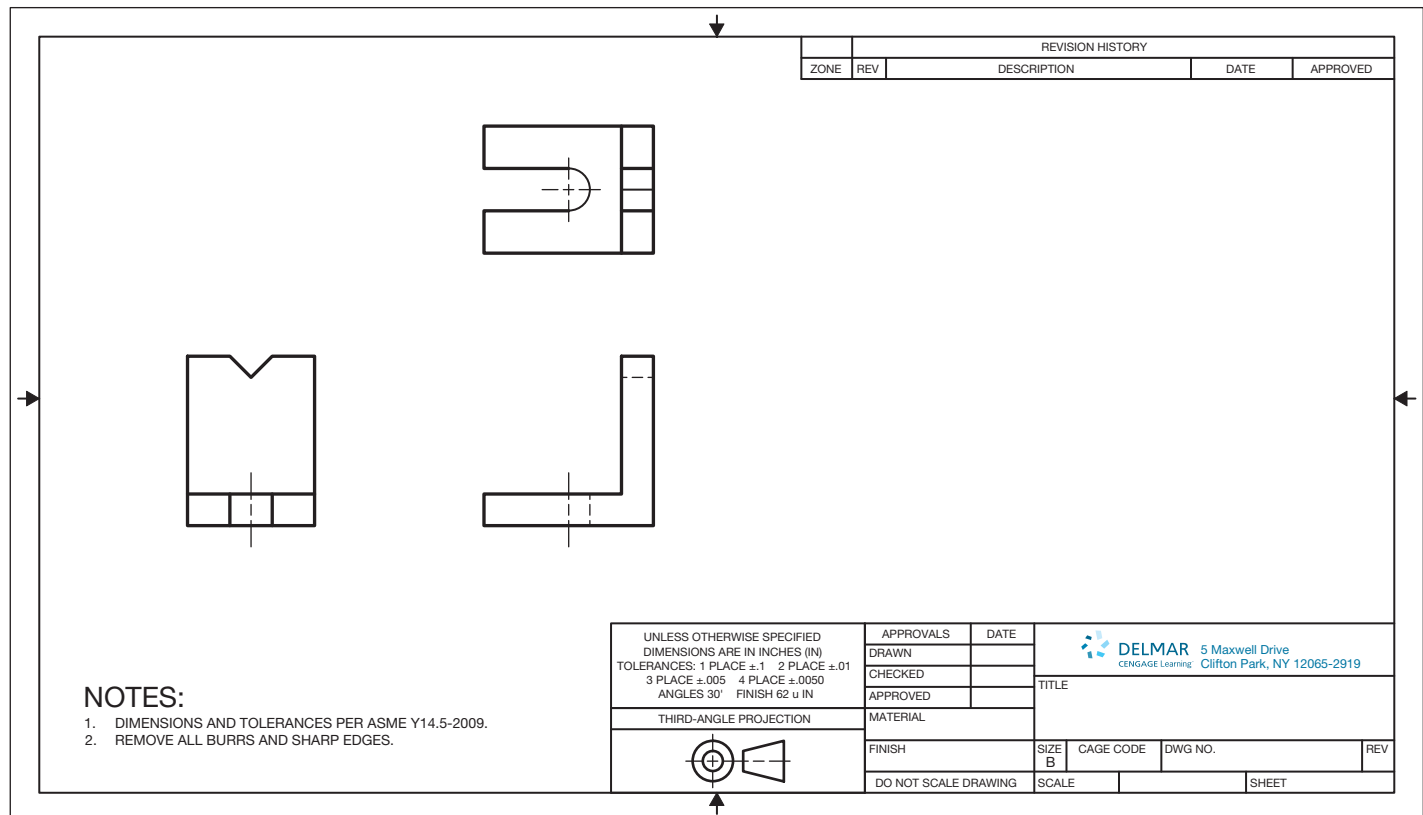


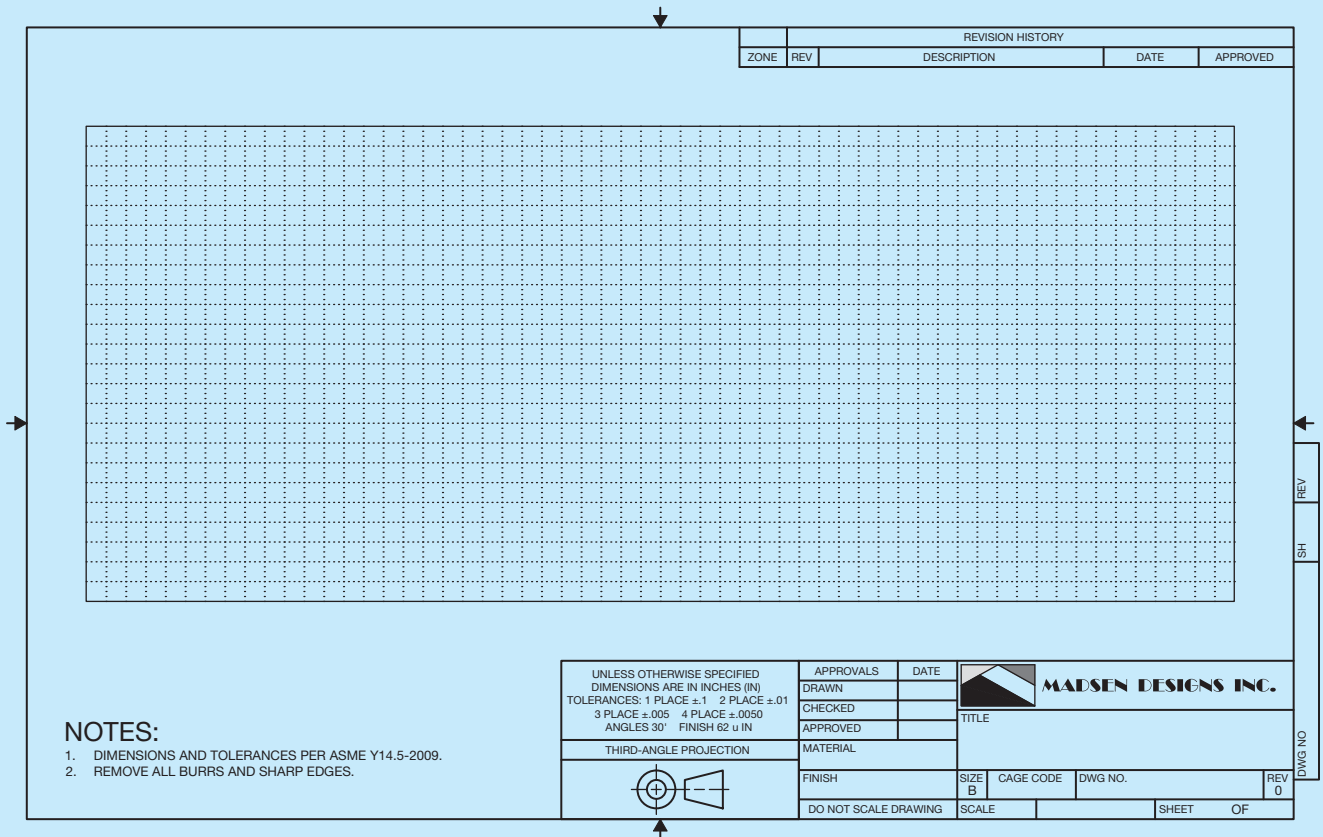
FIGURE 8.69 Completed multiview drawing without dimensions or title block content filled in. © Cengage Learning 2012

## DRAWING LAYOUT

When setting up a CADD drawing, use a sketch to determine the total drawing area. You can then determine the sheet size and establish settings specific to the drawing, such as the working area. A major advantage to CADD is the ability to change the maximum working area of the drawing and the sheet size if you make a mistake calculating multiview layout or whenever changes require a modified layout. When using CADD, views are generally drawn

full size and then scaled as needed to fit into a paper layout before plotting or printing. This concept provides accuracy and flexibility while drawing.

Use a detailed **template** whenever possible. A CADD template is a file that contains standard settings that apply to new drawings. A template can include predefined drawing layouts, borders, title blocks, and other common drafting components, features, and standards. Figure 8.70 shows a layout found in a template file, created for drawing on a B-size sheet, using ASME drafting standards.



**FIGURE 8.70** A CADD template with predefined settings for drawing on a B-size sheet using ASME drafting standards. Courtesy Madsen Designs Inc.

## PROFESSIONAL PERSPECTIVE

If you follow the view selection guidelines discussed in this chapter, you should be able to handle any drafting project. Establishing and laying out the necessary views of a part can be one of the most challenging aspects of drafting. The views that you select and the way you lay out the drawing can make the difference between having a drawing that is easy to read and understand or a drawing that is confusing and difficult to read. The practice of view projection that you learned in

this chapter provides you with the foundation for effectively selecting and laying out multiviews. Look at the drawing in Figure 8.71. This complex part is laid out with a number of multiviews that help the reader see every surface of the part. Become familiar with practices that are used in the industry and spend as much time as you can looking at drawings that have been created by professional drafters.

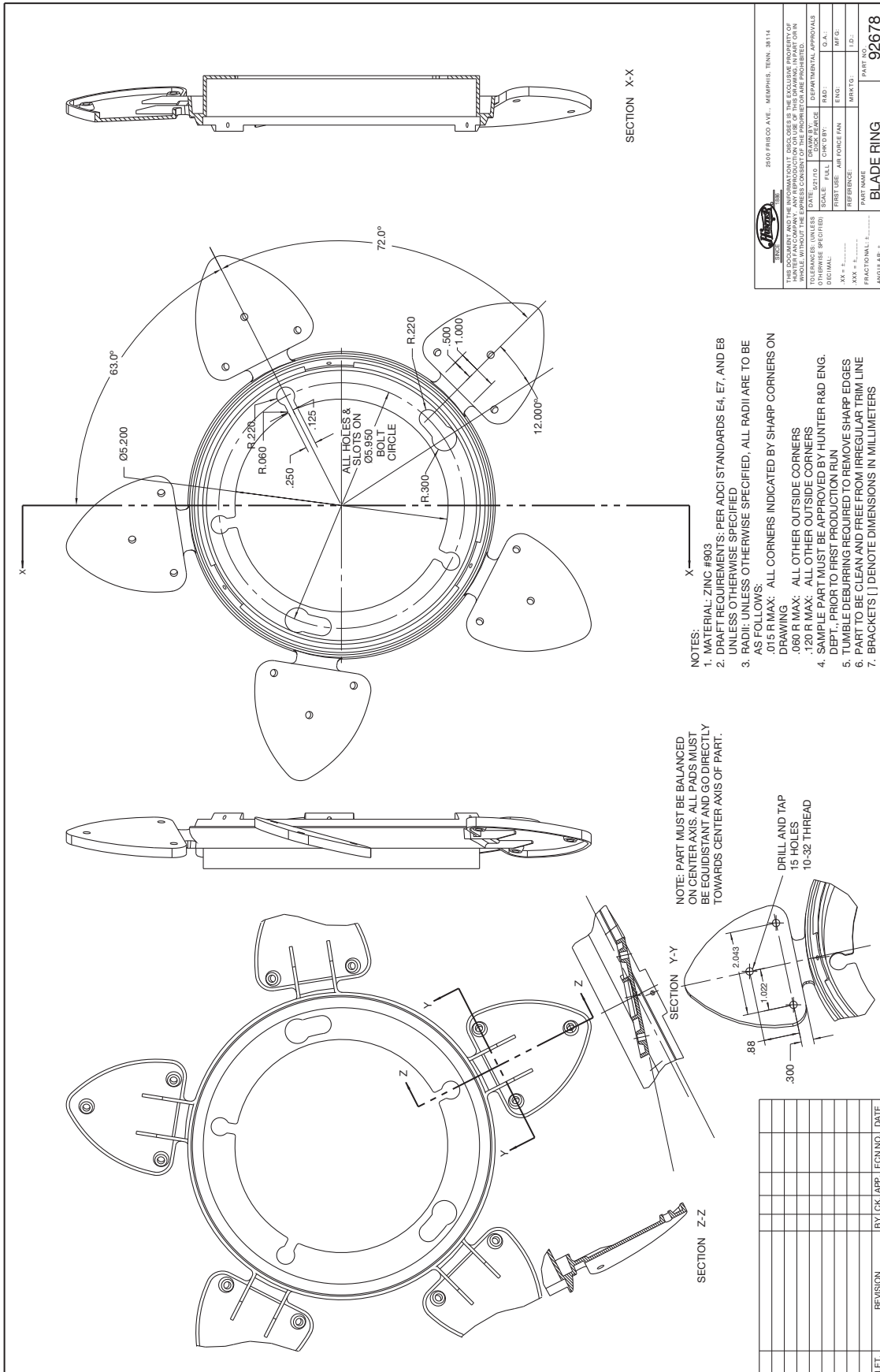


FIGURE 8.71 A complex part displayed on a drawing using several carefully selected views. Courtesy Hunter Fan Company

### WEIGHT OF AN ELLIPTICAL PLATE

**Problem:** A large steel plate in the shape of an ellipse is to be moved. The plate has the dimensions shown in Figure 8.72.

The steel is known by its thickness to weigh 19 lb/ft<sup>2</sup>. What is the weight of this plate?

**Solution:** The area of an ellipse is given by the formula,  $\text{Area} = \pi \times x \times y$ , as defined by Figure 8.73.

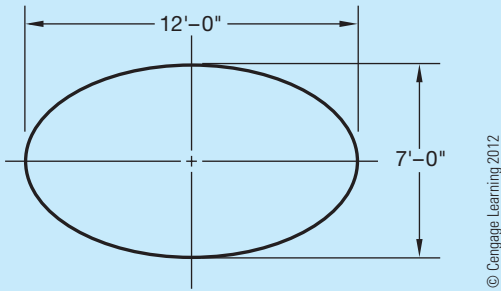


FIGURE 8.72 The major and minor diameters of the elliptical plate.

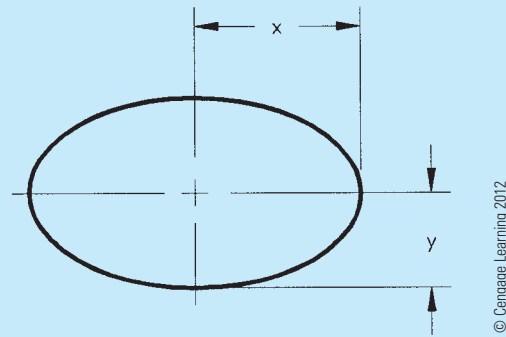


FIGURE 8.73 Ellipse.

This formula says to multiply the constant  $\pi$  (which is about 3.14159) by dimension  $x$  and then multiply that result by dimension  $y$ . For the steel plate,  $x = 6'$  and  $y = 3.5'$ , so the area is  $(3.14159)(6)(3.5)$ , or 65.98 square feet (ft<sup>2</sup>). Now the weight can be found:

$$65.98 \text{ ft}^2 \times 19 \text{ lb/ft}^2 = 1253 \text{ lb.}$$


### WEB SITE RESEARCH

Use the following Web sites as a resource to help find more information related to engineering drawing and design and the content of this chapter.

Address	Company, Product, or Service
www.asme.org	American Society of Mechanical Engineers (ASME)
www.iso.org	International Organization for Standardization
www.adda.org	American Design Drafting Association and American Digital Design Association (ADDA International)

## Chapter 8


### Chapter 8 Multiviews Test

 To access the Chapter 8 test, go to the Student CD, select **Chapter Tests and Problems**, and then **Chapter 8**. Answer the questions

with short, complete statements, sketches, or drawings as needed. Confirm the preferred submittal process with your instructor.

### Chapter 8 Multiviews Problems

#### Parts 1 and 2: Problems 8.1 Through 8.45

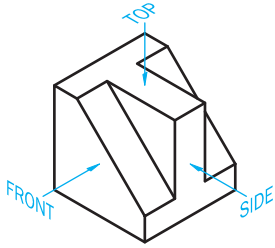
 To access the Chapter 8 problems, go to the Student CD, select **Chapter Tests and Problems** and **Chapter 8**, and then open

the problem of your choice or as assigned by your instructor. Solve the problems using the instructions provided on the CD, unless otherwise specified by your instructor.

**Part 3: Problems 8.46 Through 8.52**

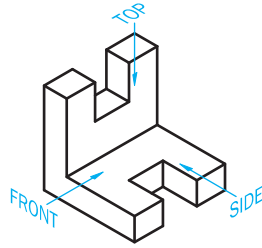
The following problems provide you with a pictorial view of an object with required views identified with arrows pointing at the viewing direction and labeled with the specific view orientation. Measure the given pictorial view and transfer your measurements to the required multiviews. Create one set of first-angle projection views and one set of third-angle projection views for each object. Label each view below the view exactly as given in the pictorial, and label each set of views as FIRST-ANGLE PROJECTION and THIRD-ANGLE PROJECTION correctly correlated to the sets of multiviews.

PROBLEM 8.46



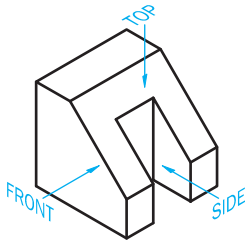
© Cengage Learning 2012

PROBLEM 8.47



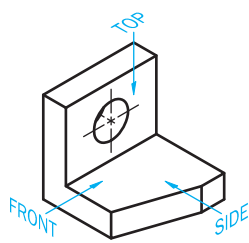
© Cengage Learning 2012

PROBLEM 8.48



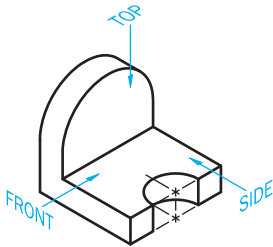
© Cengage Learning 2012

PROBLEM 8.49



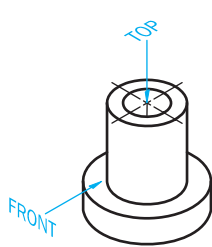
© Cengage Learning 2012

PROBLEM 8.50



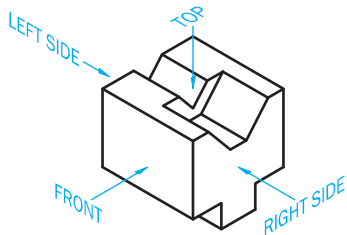
© Cengage Learning 2012

PROBLEM 8.51



© Cengage Learning 2012

PROBLEM 8.52



© Cengage Learning 2012

**Part 4: Problems 8.53 Through 8.64**

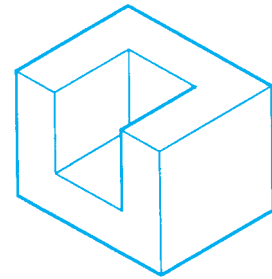
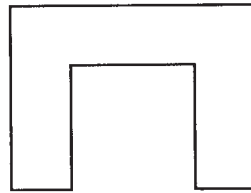
The following problems provide you with views that contain missing lines or missing views. Draw the missing lines or missing views as appropriate. Pictorial views are provided to aid in visualization. You do not need to draw the pictorial view. Measure the given views and transfer the measurements to your formal drawing. Set up your drawings with a properly sized border and title block. Use an ASME sheet and sheet blocks. Properly complete the information in the title block.



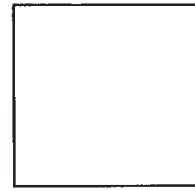
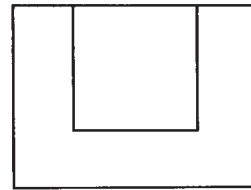
**Drafting Templates**

To access CADD template files with predefined drafting settings, go to the Student CD, select **Drafting Templates**, and select the appropriate template file. Use the templates to create new designs, as a resource for drawing and model content, or for inspiration when developing your own templates. The ASME-Inch and ASME-Metric drafting templates follow ASME, ISO, and related mechanical drafting standards. Drawing templates include standard sheet sizes and formats, and a variety of appropriate drawing settings and content. You can also use a utility such as the AutoCAD DesignCenter, to add content from the drawing templates to your own drawings and templates. Consult with your instructor to determine which template drawing and drawing content to use.

PROBLEM 8.53 Pocket block

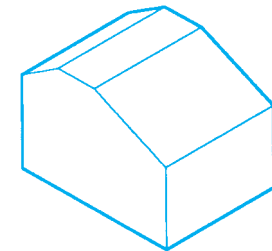
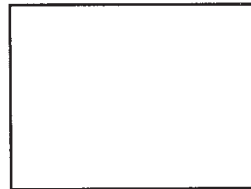


PICTORIAL

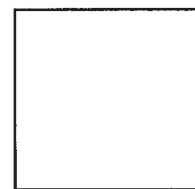
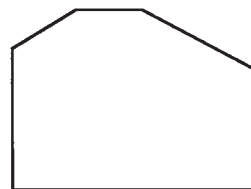


© Cengage Learning 2012

PROBLEM 8.54 Angle gage

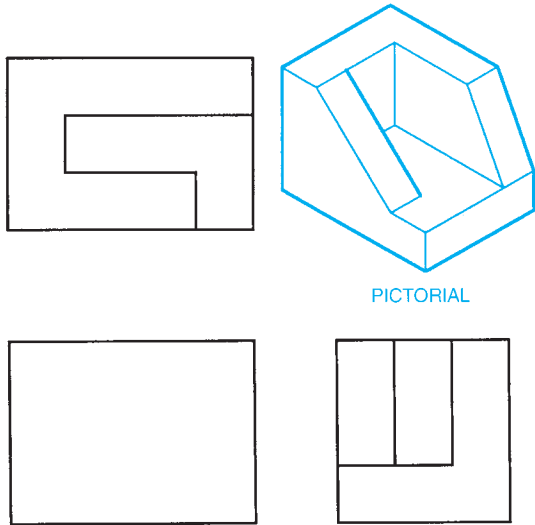


PICTORIAL



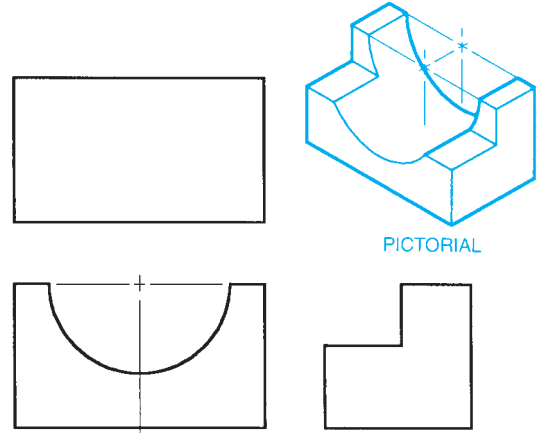
© Cengage Learning 2012

PROBLEM 8.55 Base



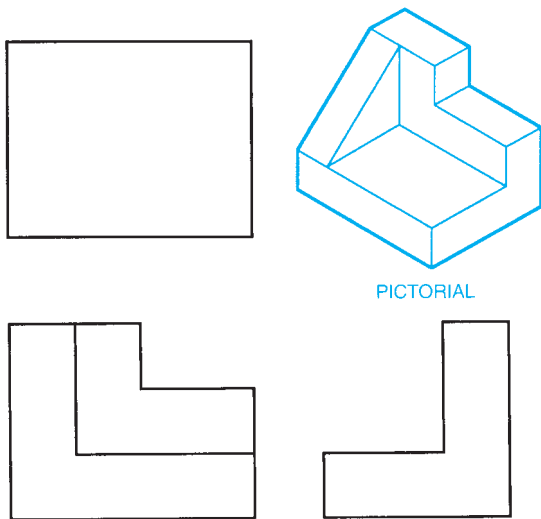
© Cengage Learning 2012

PROBLEM 8.58 Shaft block



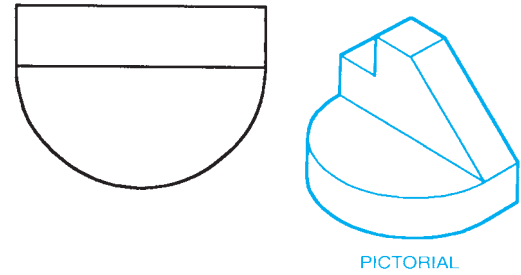
© Cengage Learning 2012

PROBLEM 8.56 Corner block



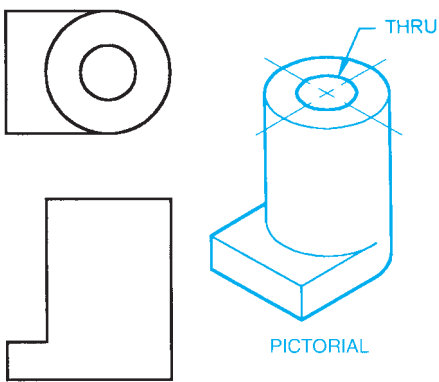
© Cengage Learning 2012

PROBLEM 8.59 Gib



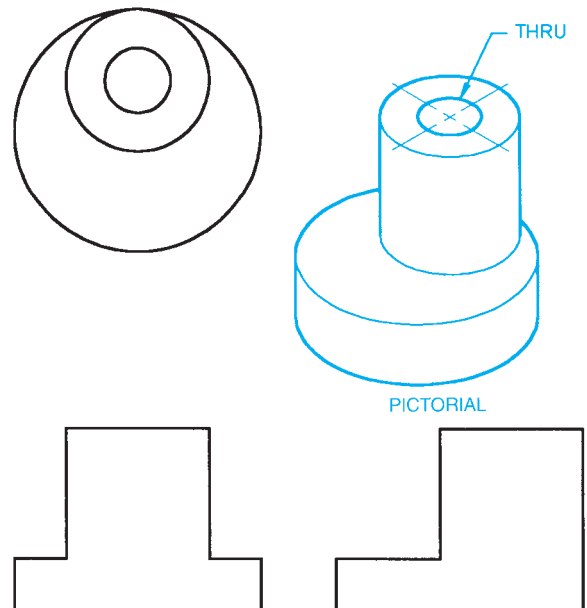
© Cengage Learning 2012

PROBLEM 8.57 Cylinder block



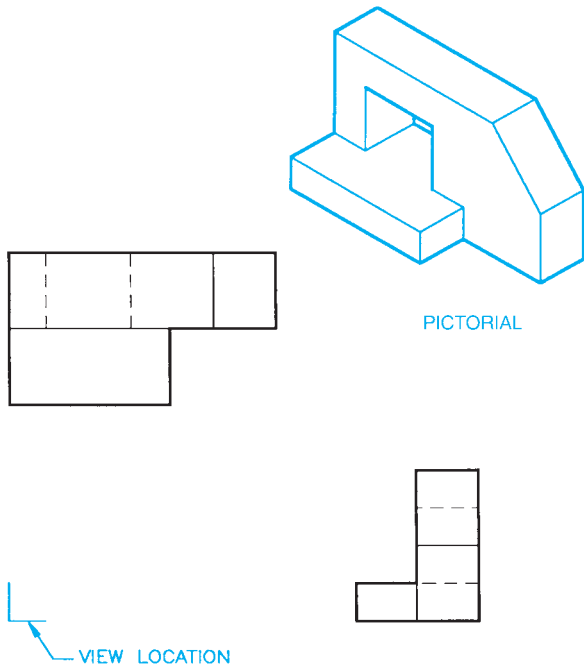
© Cengage Learning 2012

PROBLEM 8.60 Eccentric

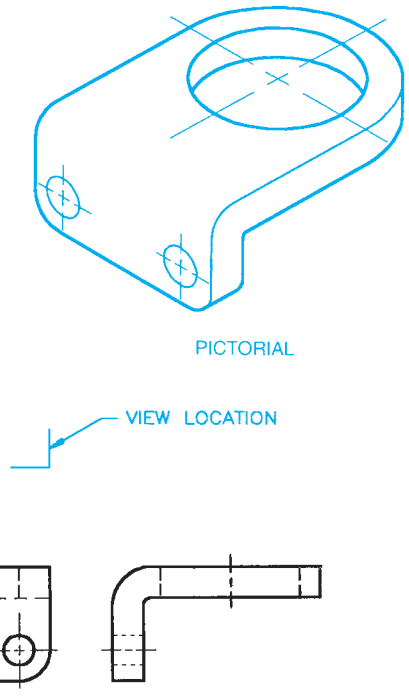


© Cengage Learning 2012

PROBLEM 8.61 Guide block



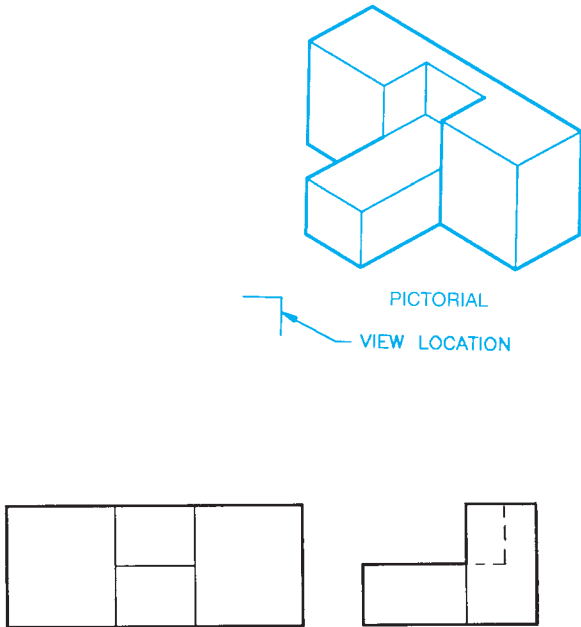
PROBLEM 8.63 Angle bracket



© Cengage Learning 2012

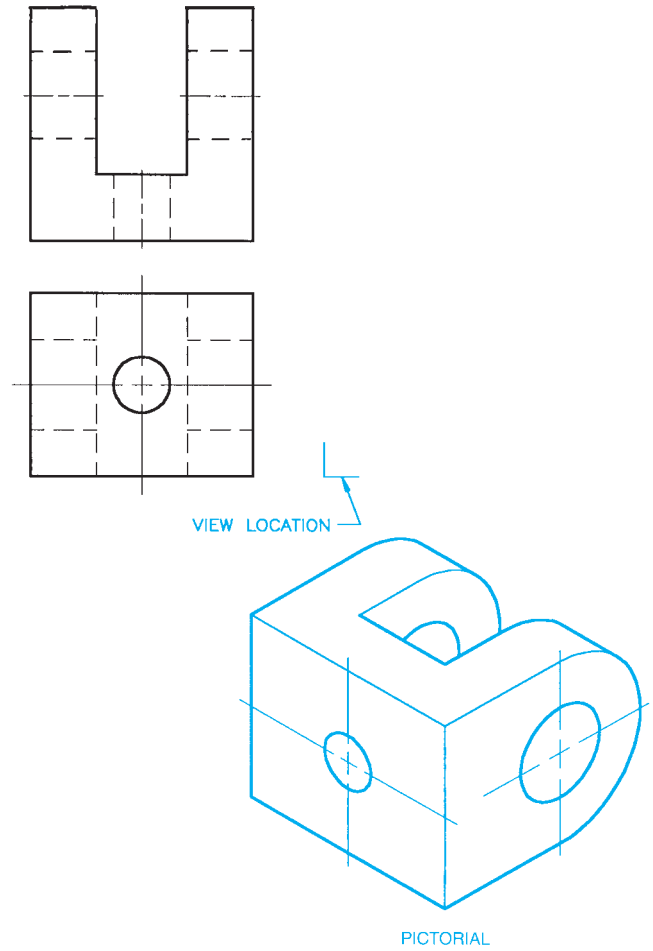
© Cengage Learning 2012

PROBLEM 8.62 Key slide



© Cengage Learning 2012

PROBLEM 8.64 Clevis

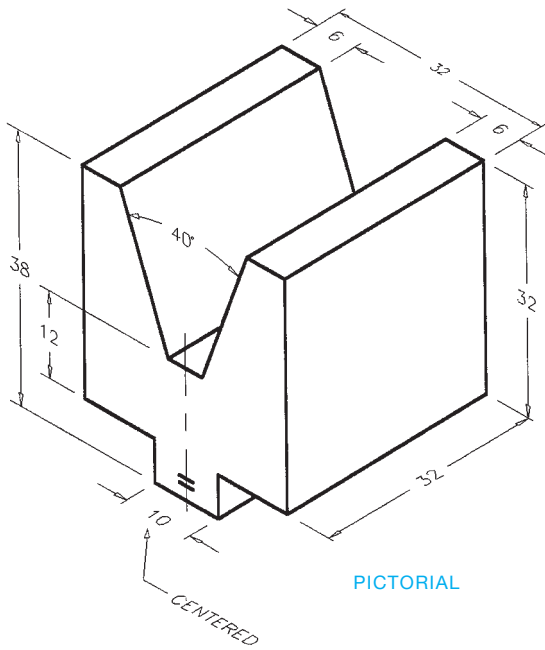
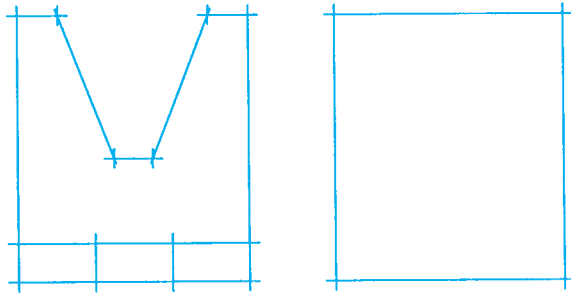


© Cengage Learning 2012

**Part 5: Problems 8.65 and 8.66**

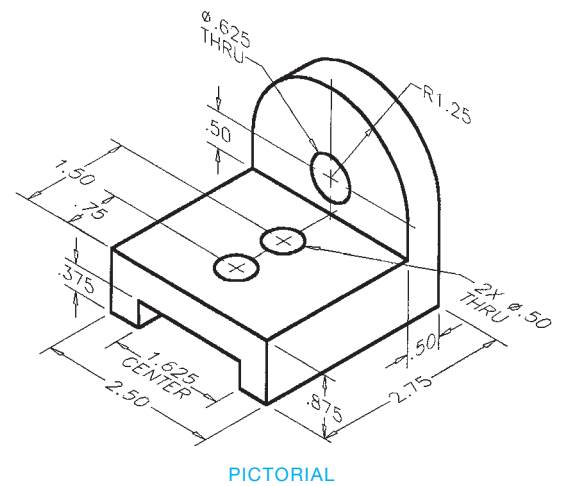
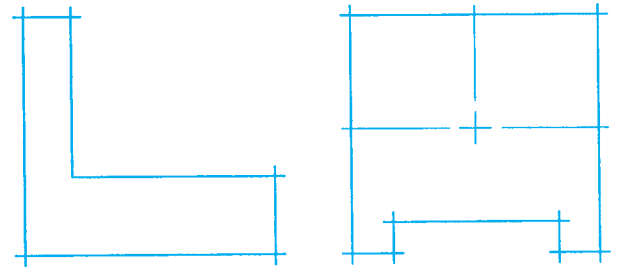
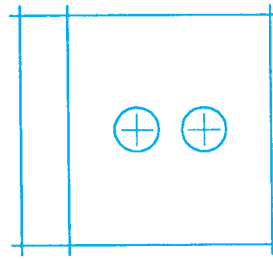
Problems 8.65 and 8.66 provide you with pictorial views that contain dimensions. A suggested view layout is provided for your reference. Draw the required views. The pictorial views are provided to aid in visualization. You do not need to draw the pictorial view. Use the given dimensions to create your formal drawing. Set up your drawings with a properly sized sheet, border, and sheet block. Properly complete the information in the title block. Do not draw the dimensions.

**PROBLEM 8.65 V-block (metric)**



© Cengage Learning 2012

**PROBLEM 8.66 Guide base (in.)**



© Cengage Learning 2012



**Part 6: Problems 8.67 Through 8.99**

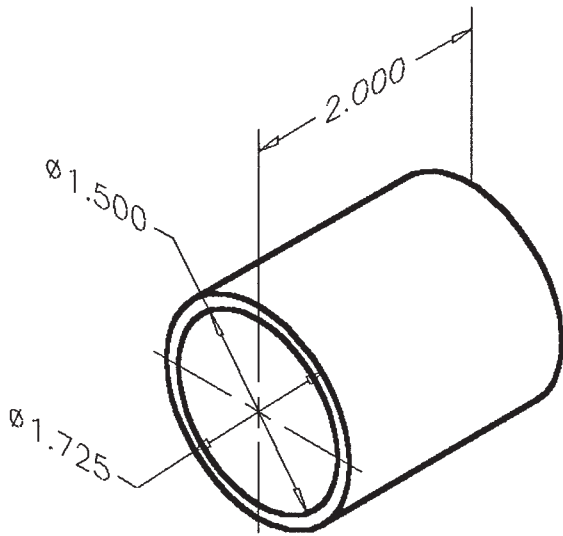
Problems 8.67 through 8.99 provide pictorial views or multiview layouts that contain dimensions. Use the given information to select and draw the necessary multiviews. In some cases, the suggested number of views is given. Do not draw the pictorial view. Set up your drawings with a properly sized sheet, border, and sheet block. Properly complete the information in the title block. Do not draw the dimensions.

**PROBLEM 8.67 One-view cylindrical object (in.)**

Part Name: Sleeve bearing

Material: Phosphor bronze

Problem based on original art courtesy of Production Plastics.

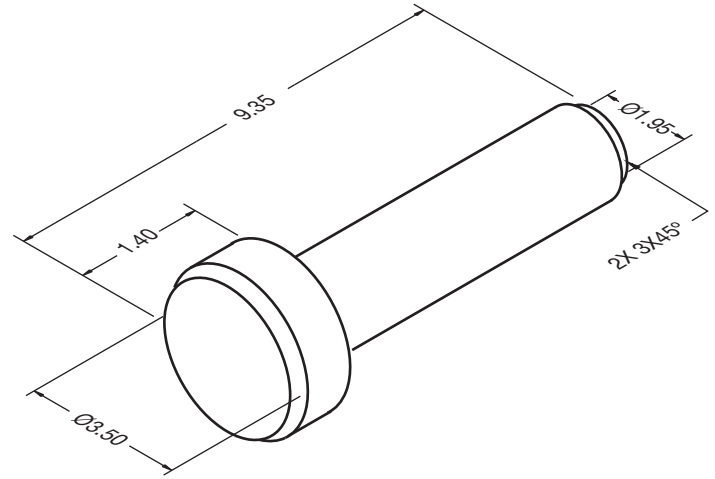


**PROBLEM 8.68 One-view cylindrical object (in.)**

Part Name: Pin

Material: SAE1035

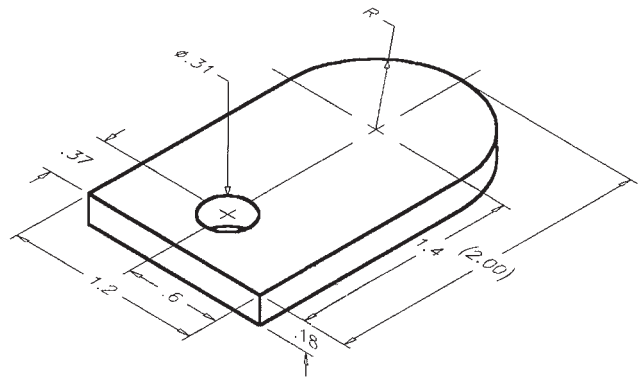
Problem based on original art courtesy of Production Plastics.



**PROBLEM 8.69 One-view arc and hole (in.)**

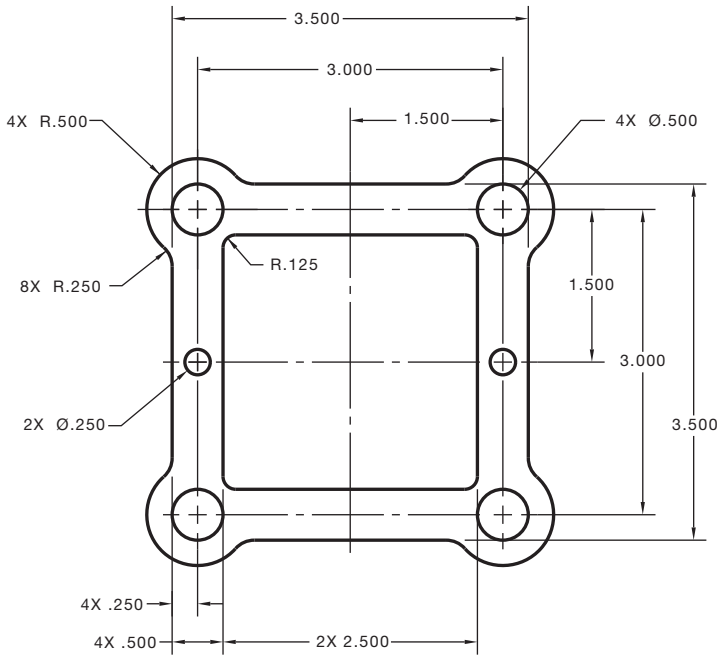
Part Name: Door Lock

Material: Mild steel



**PROBLEM 8.70 One-view arcs, circles, and centerlines (in.)**

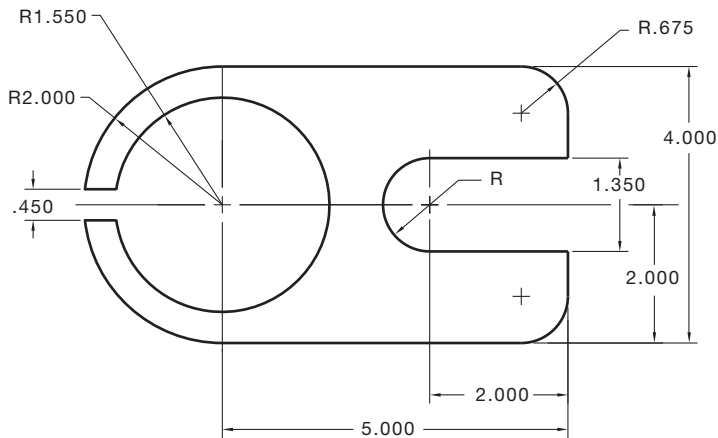
Part Name: Gasket  
 Material: .050 in. thick brass



© Cengage Learning 2012

**PROBLEM 8.71 One-view arcs and centerlines (in.)**

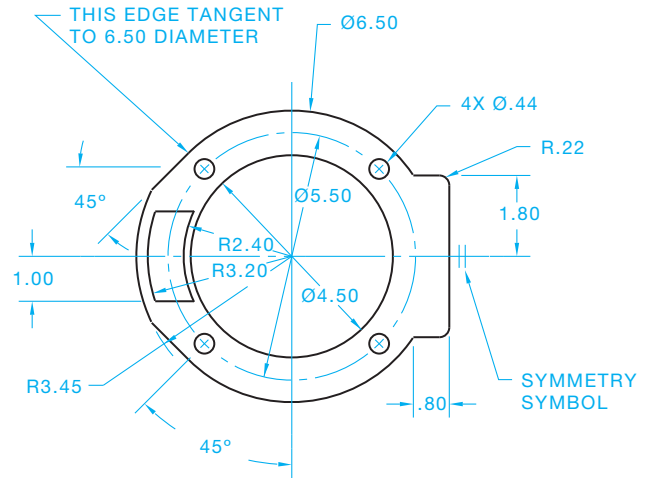
Part Name: Clip  
 Material: .025 in. thick SAE 3140



© Cengage Learning 2012

**PROBLEM 8.72 One-view circle and arc object lines and centerlines (in.)**

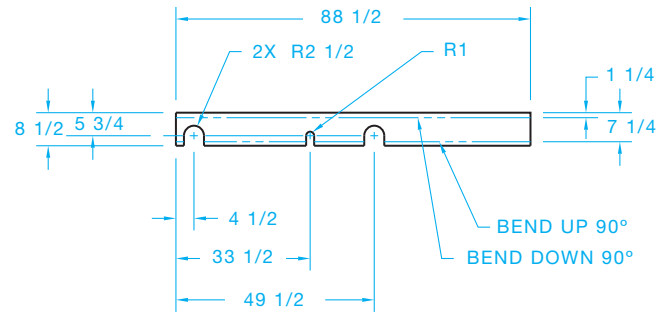
Part Name: Gasket  
 Material: .062 in. thick cork  
 Gasket for hydraulic pump.



© Cengage Learning 2012

**PROBLEM 8.73 Arc object lines, centerlines, phantom lines, and leader lines (in.)**

Part Name: Bogie Lock  
 Material: .25 in. thick mild steel  
 Specific Instructions: Connect the leader lines and place the notes on the drawing.

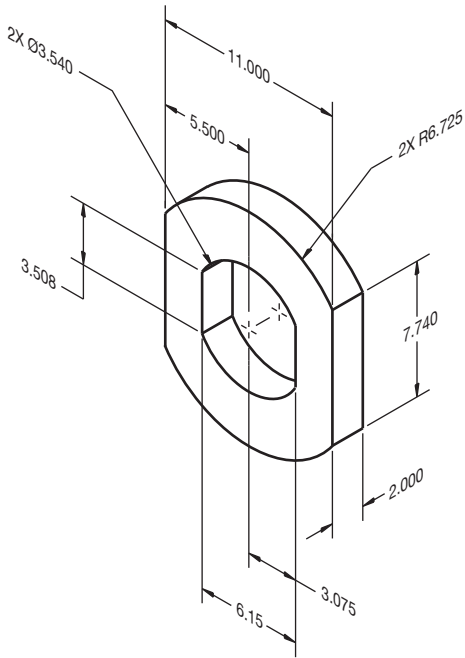


© Cengage Learning 2012

**NOTE:** Make bend line centerline type.

**PROBLEM 8.74** Two views nontangent arcs (in.)

Part Name: Washer  
Material: SAE 1060

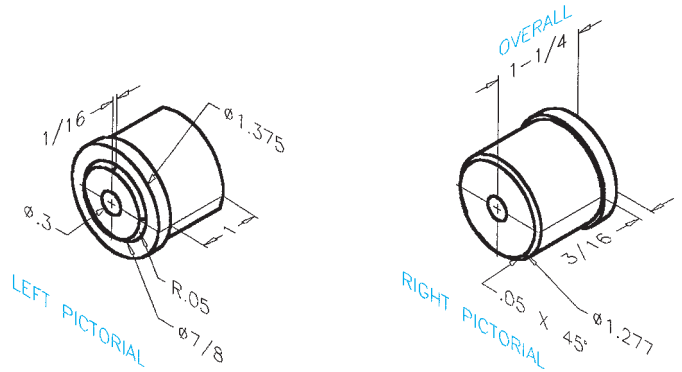


© Cengage Learning 2012

**PROBLEM 8.76** Cylinders and circles (in.)

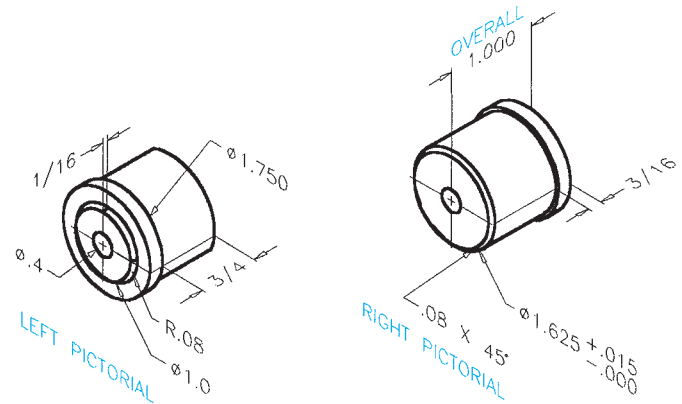
Part Name: Roll End Bearing  
Material: Phosphor bronze

Problem based on original art courtesy of Production Plastics.



**PROBLEM 8.77** Cylinders and circles (in.)

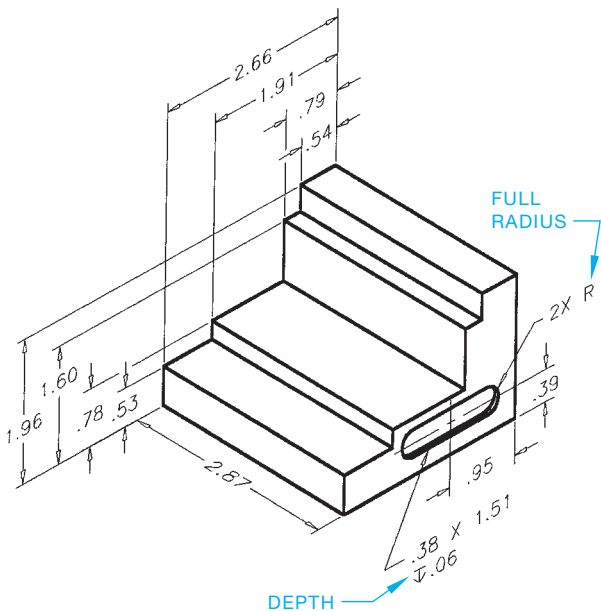
Part Name: Roll End Bearing  
Material: Phosphor bronze



© Cengage Learning 2012

**PROBLEM 8.75** Planes and slot (in.)

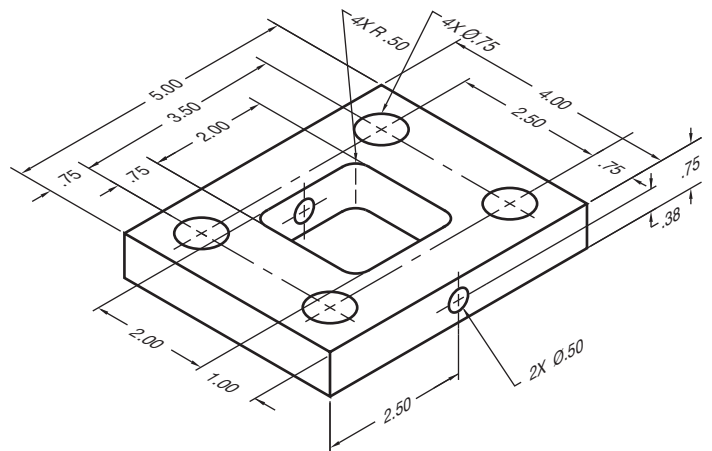
Part Name: Step Block  
Material: Mild steel



© Cengage Learning 2012

**PROBLEM 8.78** Two views with holes (in.)

Part Name: Pivot Bracket  
Material: SAE 3135

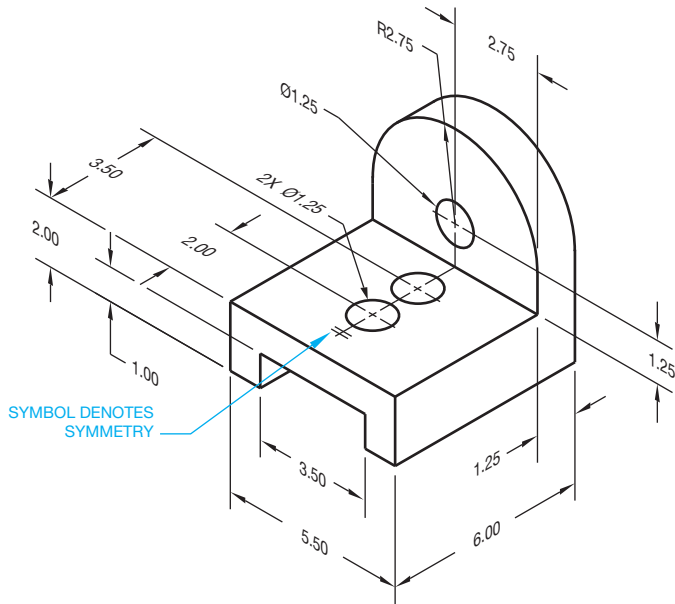


© Cengage Learning 2012

**PROBLEM 8.79 Three views with holes and slot (in.)**

Part Name: Sliding Bracket

Material: Phosphor bronze

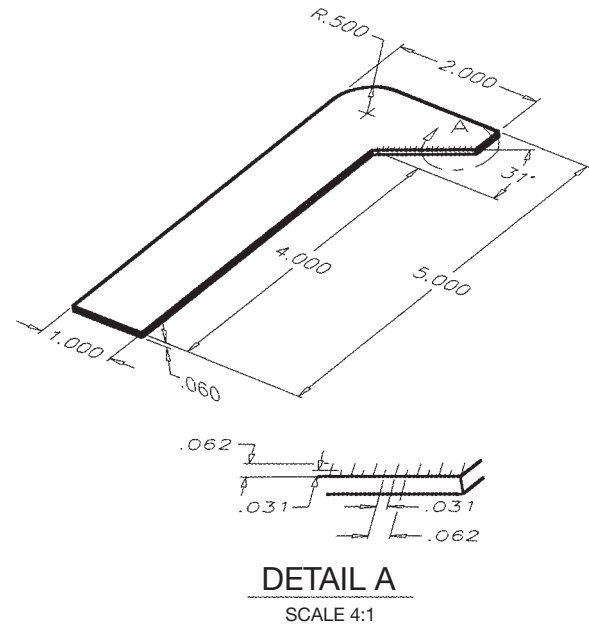


© Cengage Learning 2012

**PROBLEM 8.81 View enlargement (in.)**

Part Name: Drill Gauge

Material: 16-GA mild steel

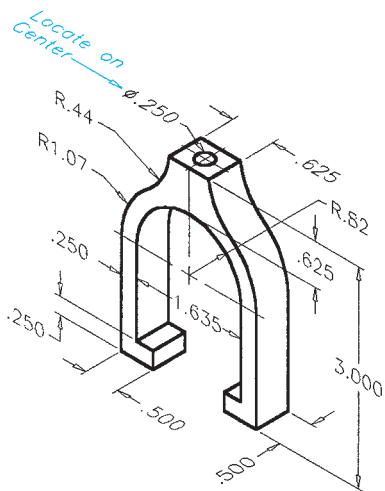


© Cengage Learning 2012

**PROBLEM 8.80 Circle arcs and planes (in.)**

Part Name: V-block Clamp

Material: SAE 1080

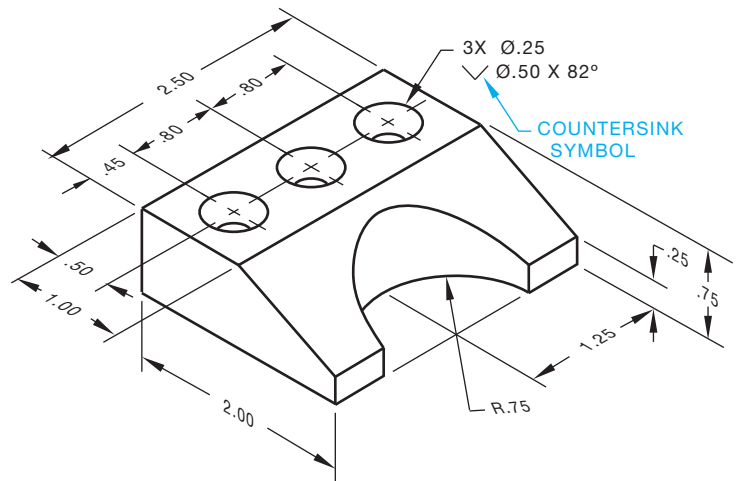


© Cengage Learning 2012

**PROBLEM 8.82 Two views with angled surface, countersinks (in.)**

Part Name: Angle Bracket

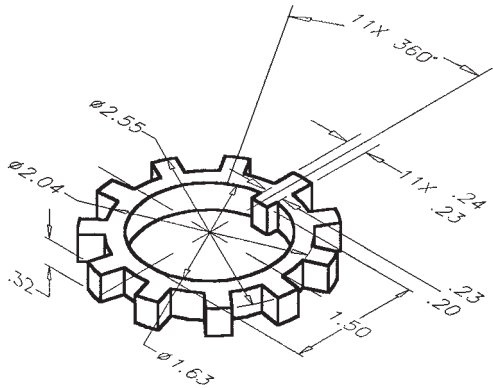
Material: SAE 1145



© Cengage Learning 2012

**PROBLEM 8.83 Multiple features (in.)**

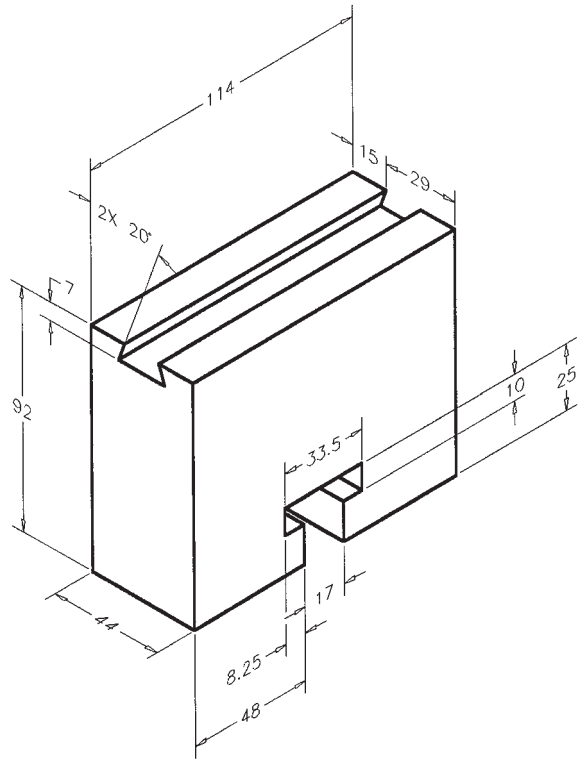
Part Name: Lock Ring  
Material: SAE 1020



© Cengage Learning 2012

**PROBLEM 8.85 Multiviews (metric)**

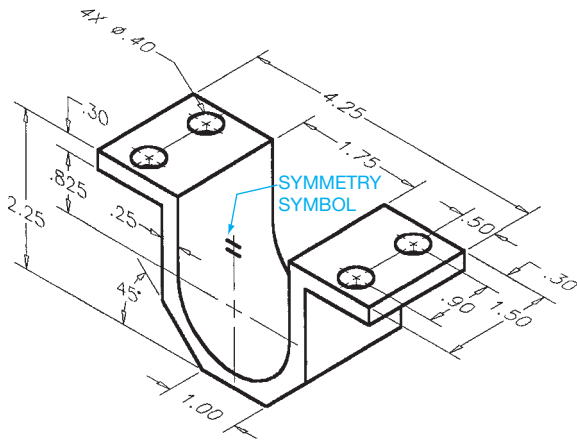
Part Name: Guide Rail  
Material: SAE 4310



© Cengage Learning 2012

**PROBLEM 8.84 Angles and holes (in.)**

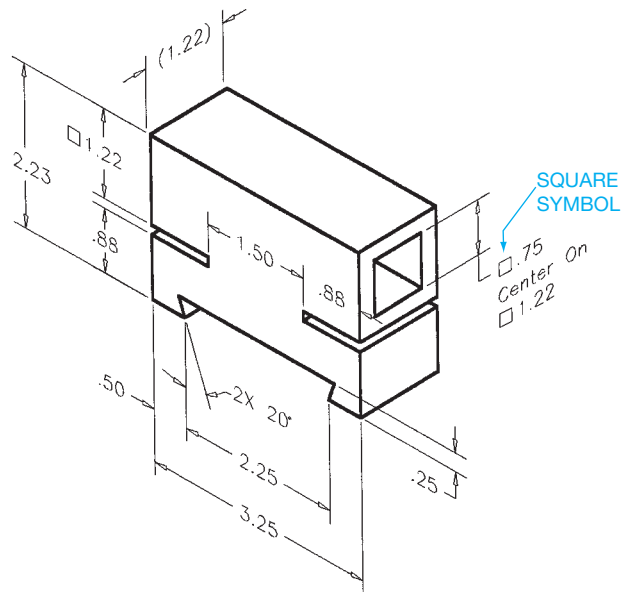
Part Name: Bracket  
Material: SAE 1020



© Cengage Learning 2012

**PROBLEM 8.86 Multiviews (in.)**

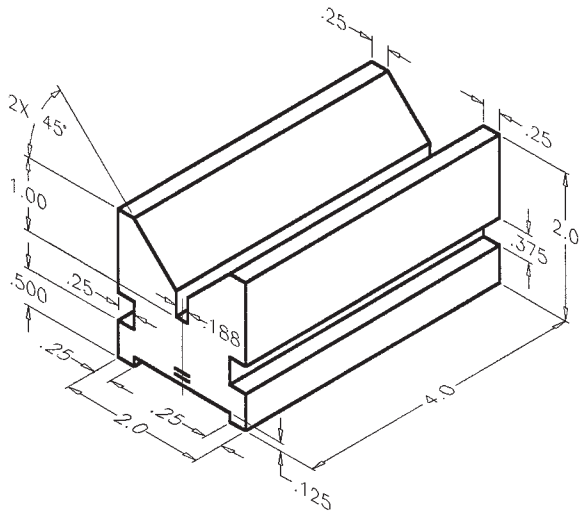
Part Name: Support Bracket  
Material: Plastic



© Cengage Learning 2012

**PROBLEM 8.87 Multiviews (in.)**

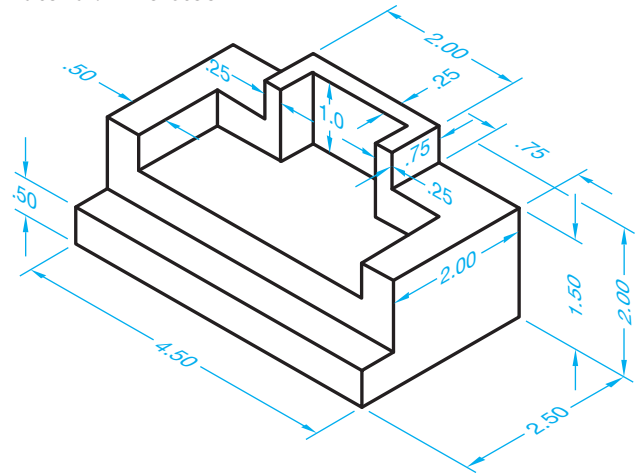
Part Name: V-block  
Material: A-steel



© Cengage Learning 2012

**PROBLEM 8.89 Multiviews (in.)**

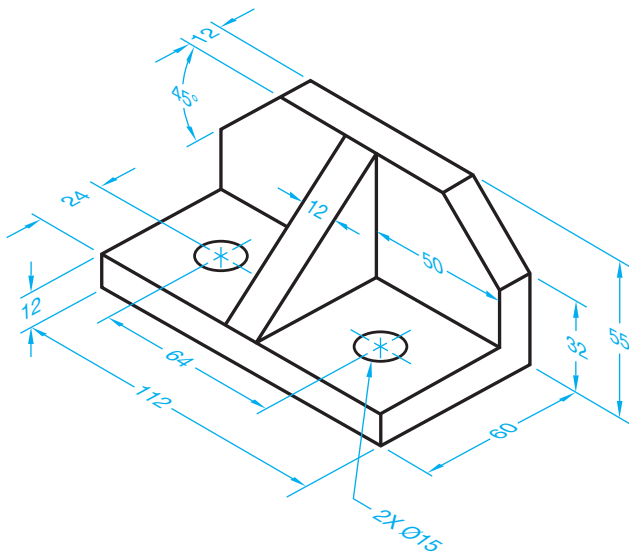
Part Name: Support  
Material: Mild steel



© Cengage Learning 2012

**PROBLEM 8.88 Multiviews, angles, and holes (metric)**

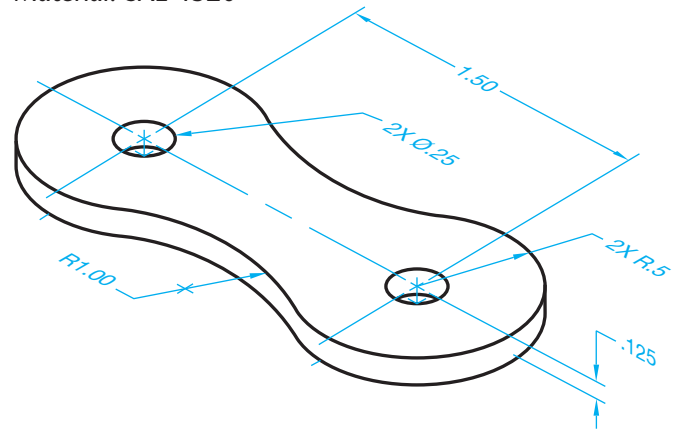
Part Name: Angle Bracket  
Material: Mild steel  
Specific Instructions: Center 2X Ø15 holes and provide location dimension.



© Cengage Learning 2012

**PROBLEM 8.90 Multiviews, circles, and arcs (in.)**

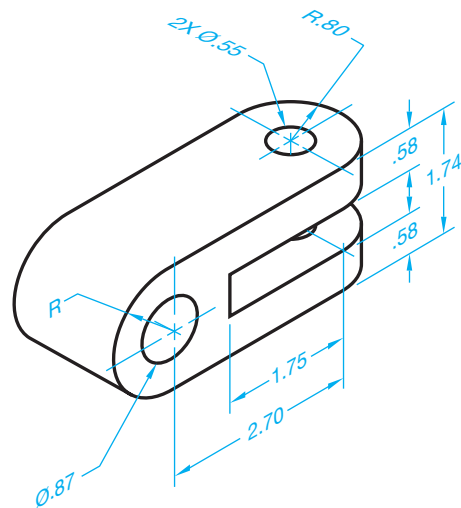
Part Name: Chain Link  
Material: SAE 4320



© Cengage Learning 2012

**PROBLEM 8.91 Multiviews, circles, and arcs (in.)**

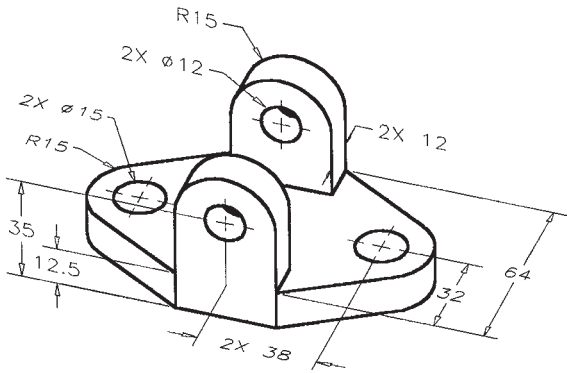
Part Name: Pivot Bracket  
Material: Cold-rolled steel



© Cengage Learning 2012

**PROBLEM 8.92 Multiview arcs and circles (metric)**

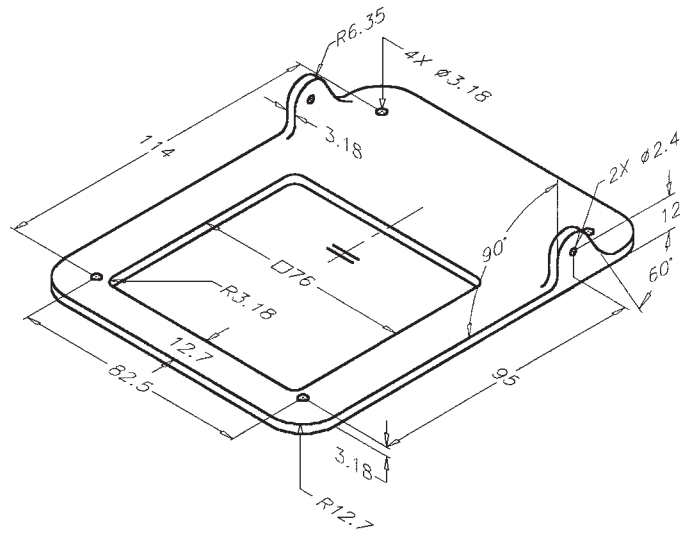
Part Name: Hinge Bracket  
Material: Cast aluminum



© Cengage Learning 2012

**PROBLEM 8.94 Multiviews (metric)**

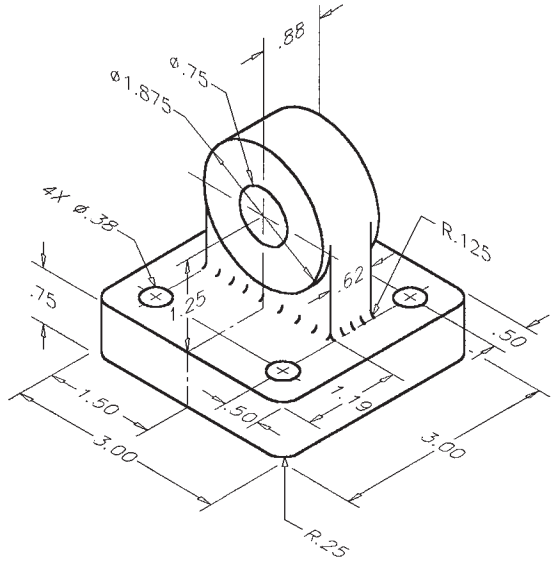
Part Name: Gate Latch Base  
Material: Aluminum



© Cengage Learning 2012

**PROBLEM 8.93 Multiview circles and arcs (in.)**

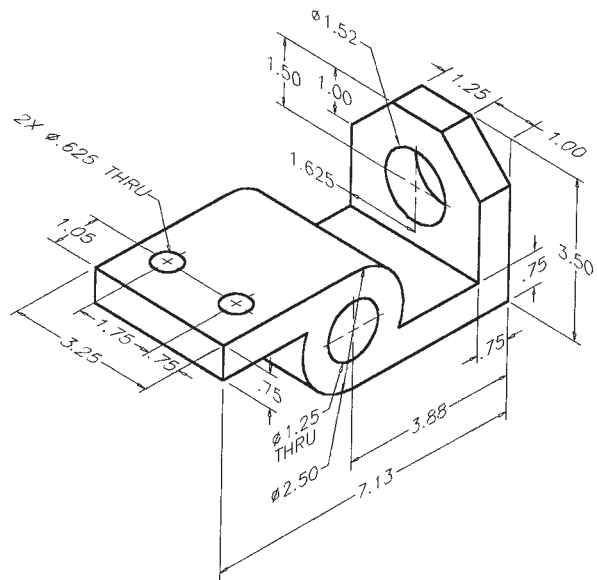
Part Name: Bearing Support  
Material: SAE 1040



© Cengage Learning 2012

**PROBLEM 8.95 Multiviews (in.)**

Part Name: Mounting Bracket  
Material: SAE 1020  
All Fillets: R.13

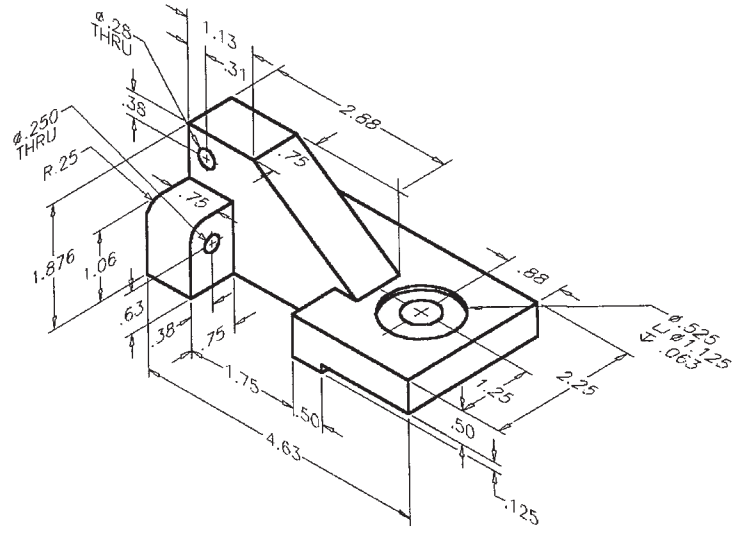


© Cengage Learning 2012

**PROBLEM 8.96 Multiviews (in.)**

Part Name: Support Base

Material: SAE 1040



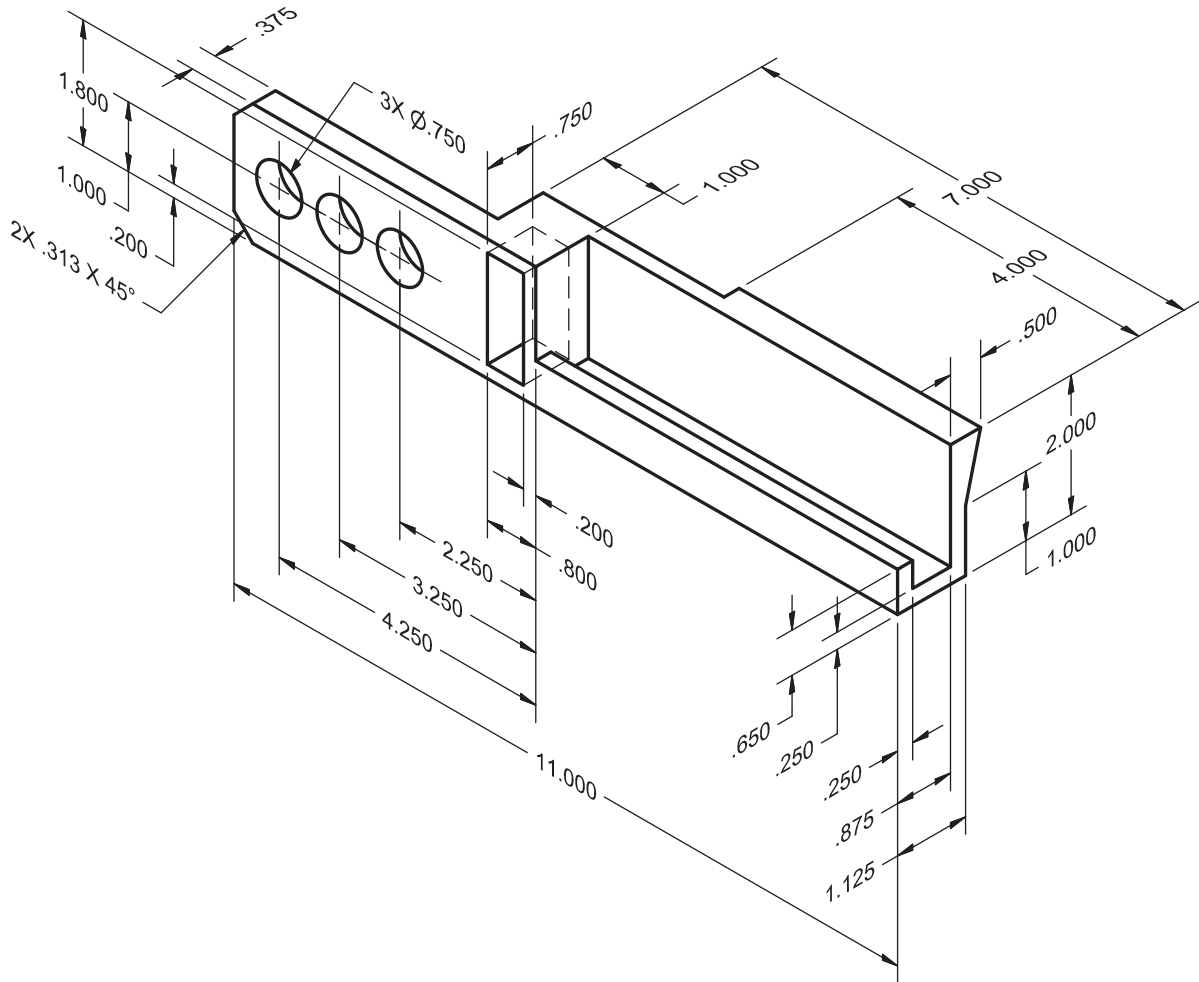
© Cengage Learning 2012

**PROBLEM 8.97 Multiviews (in.) removed view**

Part Name: Draw Bar

Material: SAE 4320

Draw a front view, top view, and standard removed view using a labeled viewing-plane line and correlated removed side view.



© Cengage Learning 2012

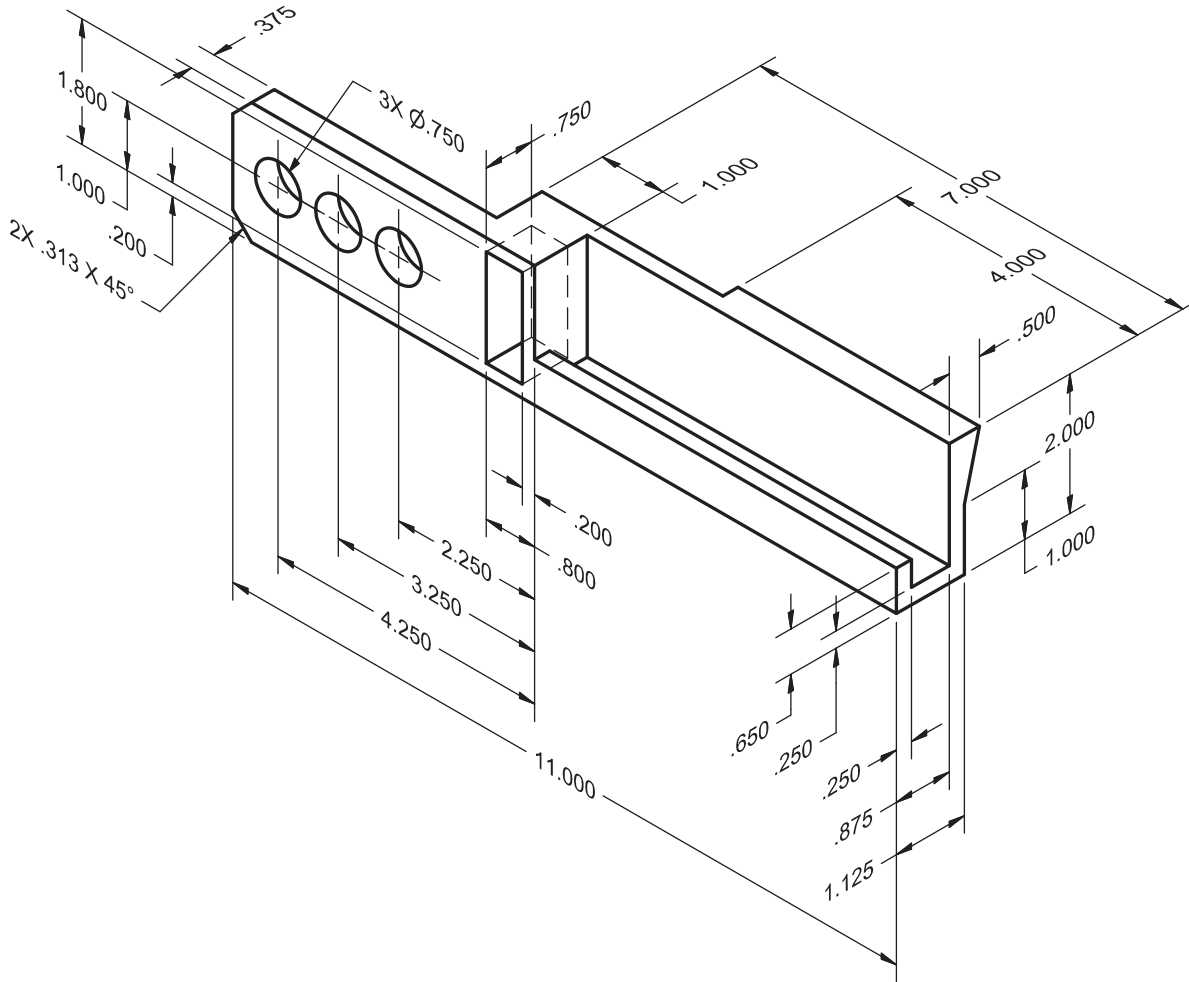


PROBLEM 8.98 Multiviews (in.) removed view arrow method

Part Name: Draw Bar

Material: SAE 4320

Using the same part shown in Problem 8.97, draw a front view, top view, and removed view using the arrow method. Label the viewing arrow and correlated removed side view.



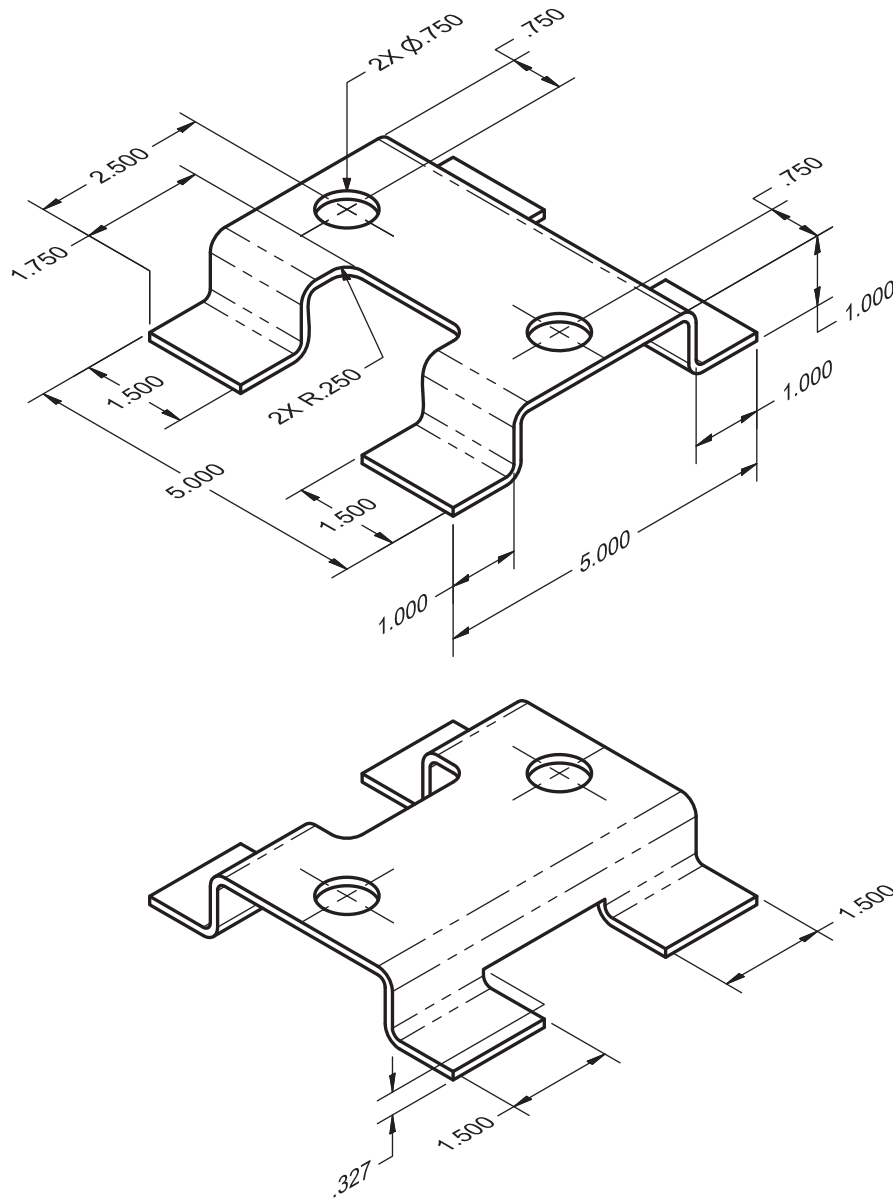
© Cengage Learning 2012

**PROBLEM 8.99** Multiviews (in.) sheet metal part

Part Name: Bracket

Material: 11 gage (.1196 in.) SAE 1040 steel.

The bend radius is equal to the thickness of the material.



© Cengage Learning 2012

**Math Problems**

**Part 7: Problems 8.100 Through 8.110**



To access the Chapter 8 problems, go to the Student CD, select **Chapter Tests and**

**Problems and Chapter 8**, and then open the math problem of your choice or as assigned by your instructor. Solve the problems using the instructions provided on the CD, unless otherwise specified by your instructor.

## Auxiliary Views

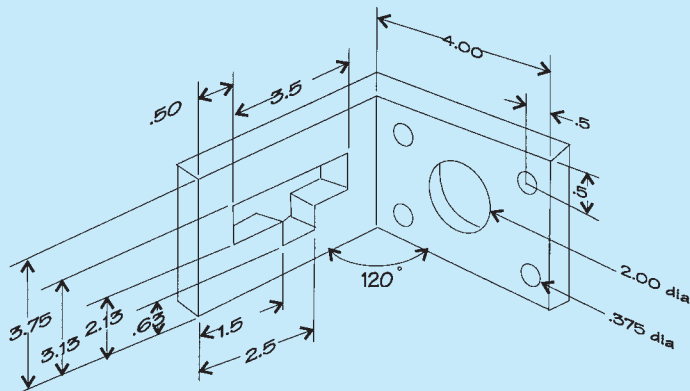
### LEARNING OBJECTIVES

After completing this chapter, you will:

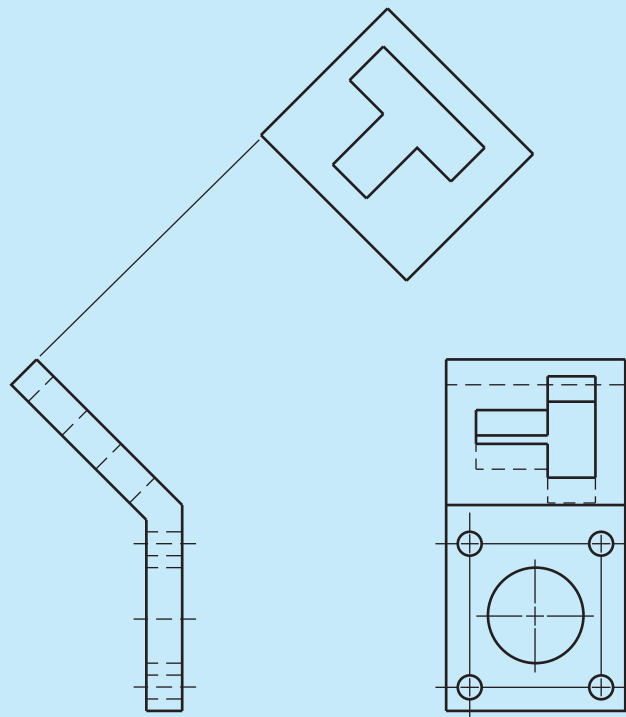
- Describe the purpose of an auxiliary view.
- Explain how an auxiliary view is projected.
- Discuss and draw viewing-plane lines related to auxiliary views.
- Draw primary and secondary auxiliary views along with the related multiviews from given engineering problems.

## THE ENGINEERING DESIGN APPLICATION

You have been asked to create a multiview detail drawing for a guide bracket, and the engineer has provided a sketch of the part (see Figure 9.1). As you study the sketch, you discover that one of the surfaces on the bracket is not parallel to any of the six principal viewing planes. You determine that your multiview drawing needs an auxiliary view in order to show the angled face in its true size and shape as a true geometric view. Through sketching your layout ideas, you conclude that a complete auxiliary view would not add clarity to the drawing and decide instead on a partial auxiliary view. Figure 9.2 shows the final layout.



**FIGURE 9.1** Engineer's rough sketch. © Cengage Learning 2012



**FIGURE 9.2** Final layout with partial auxiliary view (dimensions not included). © Cengage Learning 2012

### STANDARDS

**ASME** The standard for auxiliary view presentation is found in ASME Y14.3, *Multi and Sectional View Drawings*.

### AUXILIARY VIEWS

**Auxiliary views** are used to show the true size and shape of a surface that is not parallel to any of the six principal

views. Reasons for using auxiliary views include the following:

- To find the true length of a sloping line.
- To find the true size and shape of an inclined surface.
- To find the point view of an inclined line.
- To look at the object in a different plane that is not one of the principal planes so the object can be viewed differently or to start successive auxiliary views.

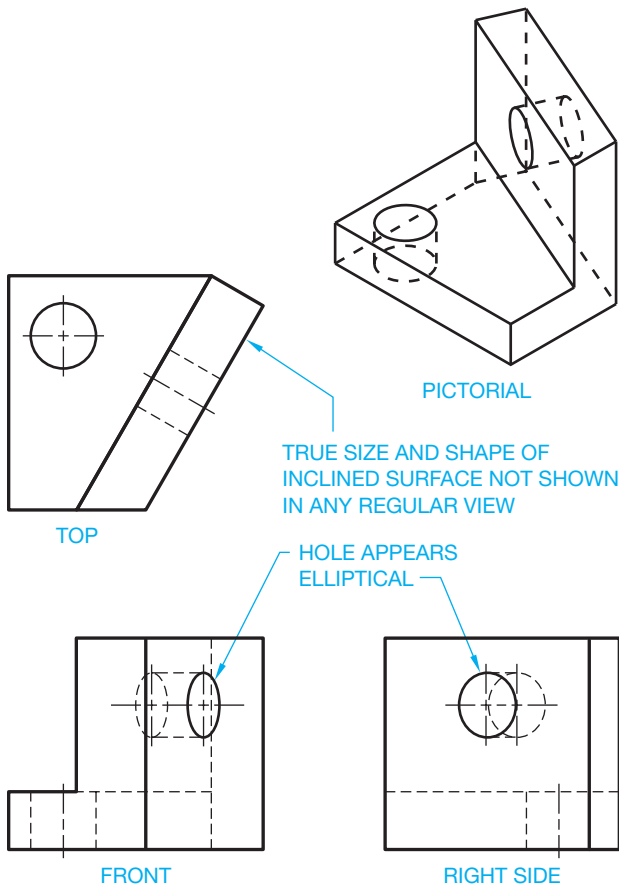


FIGURE 9.3 Foreshortened surface auxiliary view.

When a surface feature is not perpendicular to the line of sight, the feature is said to be *foreshortened* or to be shorter than true length. These foreshortened views do not give a clear or accurate representation of the feature. It is not proper to place dimensions on foreshortened views of objects. Figure 9.3 shows three views of an object with an inclined foreshortened surface.

An auxiliary view allows you to look directly at the inclined surface in Figure 9.3 so you can view the surface and locate the hole in its true size and shape. An auxiliary view is projected from the inclined surface in the view where the inclined surface appears as a line or edge. The projection is at a 90° angle from the view where the inclined surface appears as a line (see Figure 9.4). The height dimension, *H*, is taken from the view that shows the height in its true length.

Notice in Figure 9.4 that the auxiliary view shows only the true size and shape of the inclined surface. This is known as a **partial auxiliary view**. The **full auxiliary view** in Figure 9.5 shows the true size and shape of the inclined surface and all the other features of the object projected onto the auxiliary plane. Normally, a partial auxiliary view is used because the partial auxiliary view shows only what you need to provide the true geometry of the inclined surface. The other features do not usually add clarity to the view.

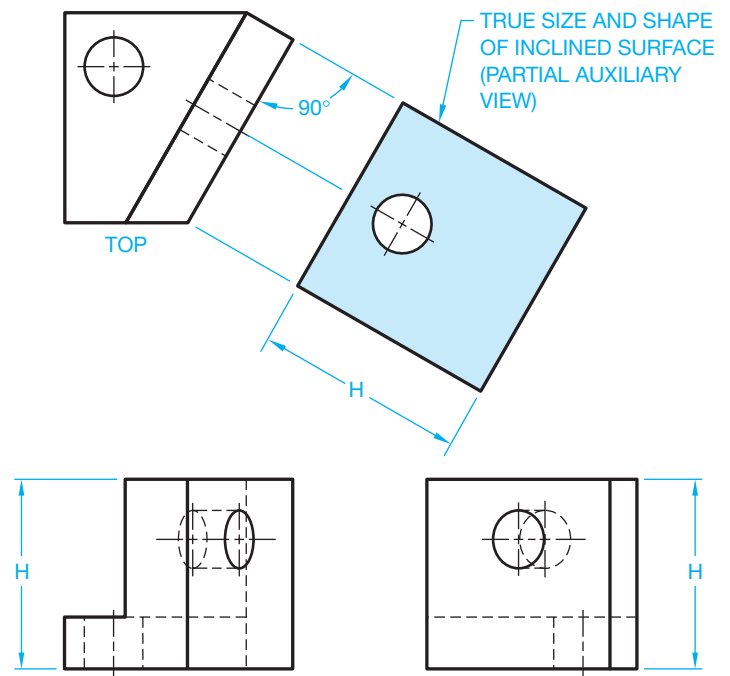


FIGURE 9.4 Partial auxiliary view. © Cengage Learning 2012

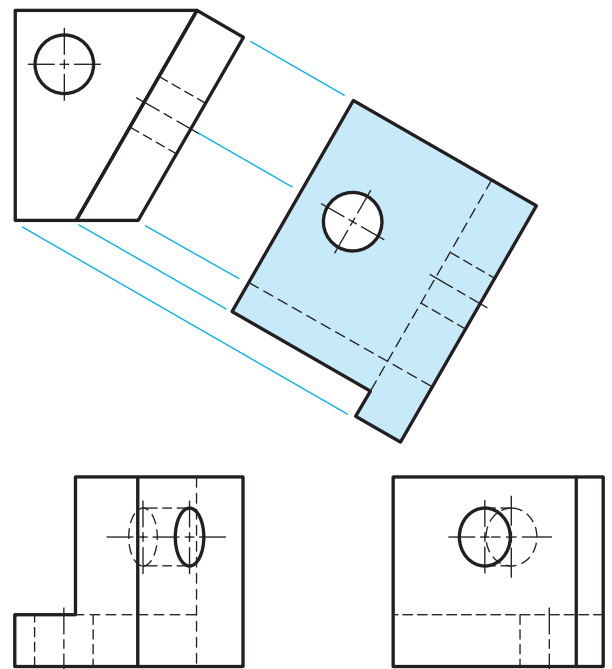


FIGURE 9.5 Complete auxiliary view. © Cengage Learning 2012

The glass box method of visualization was introduced in Chapter 8. Look at the glass box principal shown in Figure 9.6 as it applies to auxiliary views. Notice that there are planes on the glass box that establish the front, top, and right-side views. There is also a plane parallel to the inclined surface used to

establish the auxiliary view. Figure 9.7 shows the glass box unfolded. Notice that the fold line between the front view and the auxiliary view is parallel to the edge view of the slanted surface. The auxiliary view is projected 90° from the edge view

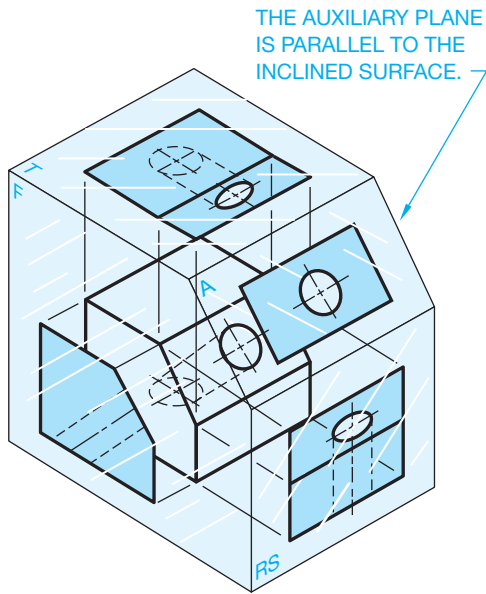


FIGURE 9.6 The object in a glass box.

of the inclined surface. This projection establishes true length. The true width of the inclined surface can be transferred from the fold lines of the top or side views as shown in Figure 9.8.

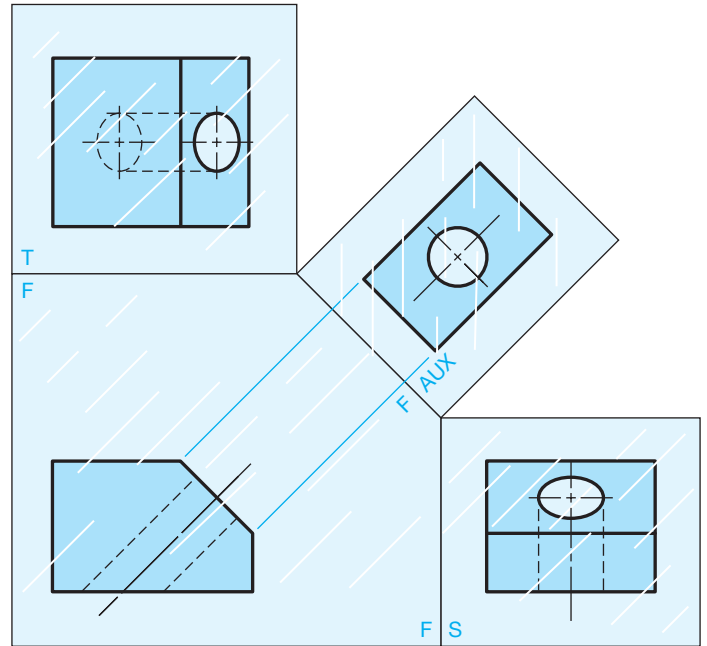
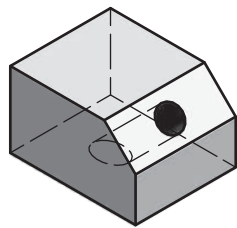
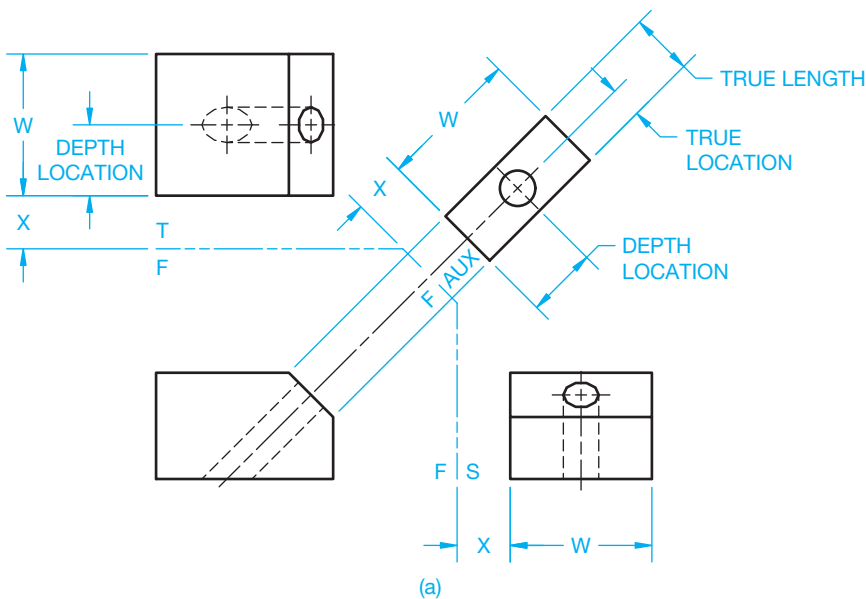


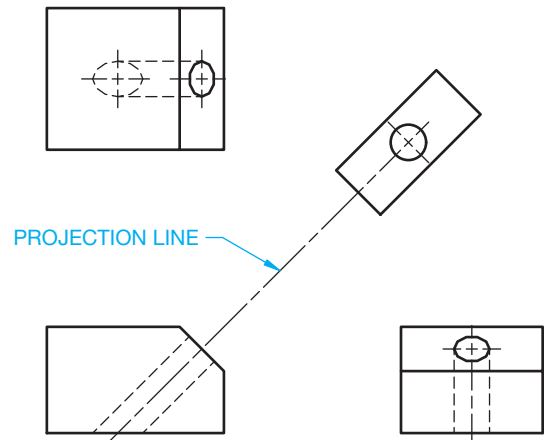
FIGURE 9.7 The glass box unfolded. © Cengage Learning 2012



PICTORIAL



(a)



(b)

FIGURE 9.8 (a) Establishing auxiliary view with fold lines. (b) The final multiview drawing with auxiliary view. © Cengage Learning 2012

Projection lines are drawn as construction lines and should be on a special layer that can be turned off or frozen when finished. Hidden lines are generally not shown on auxiliary views unless the use of hidden lines helps clarify certain features.

The auxiliary view can be projected directly from the inclined surface as shown in Figure 9.8a. When the auxiliary view is completed, one projection line remains between the views to indicate alignment and view relationship. The projection line that you keep on the final drawing can be from a corner or it can be a centerline that extends between views. Figure 9.8b shows the completed multiview drawing with auxiliary view. The projection centerline or projection line is often used as an

extension line for dimensioning purposes. If view alignment is clearly obvious, then the projection line can be omitted.

### AUXILIARY VIEW VISUALIZATION

Multiview and auxiliary view visualization can be difficult. It is important for you to practice looking at three-dimensional (3-D) objects and try to visualize them in two-dimensional (2-D) views in your mind. Figure 9.9 shows examples of partial auxiliary views in use. Look at the multiview and auxiliary view drawings in Figure 9.12 and compare these 2-D views to the pictorial views provided.

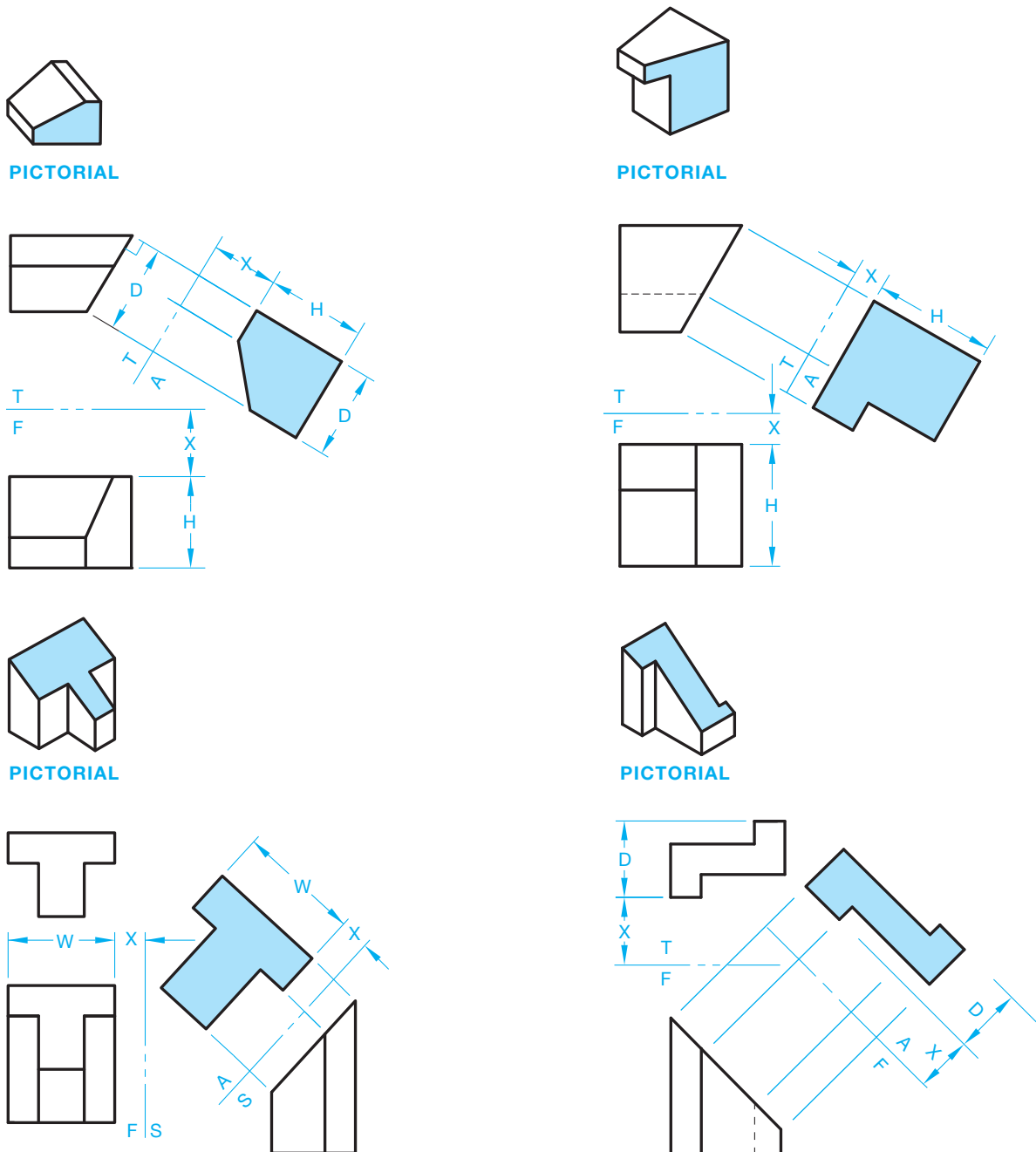


FIGURE 9.9 Partial auxiliary view examples. © Cengage Learning 2012

### Using the Mechanics of View Projection to Visualize and Draw Auxiliary Views

It is important to visualize the relationship of the slanted surfaces, edge view, and auxiliary view. If you have trouble with visualization, it is possible to establish the auxiliary view through the mechanics of view projection by using the following steps:

**STEP 1** Number each corner of the inclined view so the numbers coincide from one view to the other as shown in Figure 9.10. Carefully project one point at a time from view to view. Some points have two numbers, depending on the view. When you look at a line from the end, the line looks like a point. When you see a point with two numbers, the two numbers represent each end of the line in an end view. The first number is the end point closest to you and the second number is the end point farthest away from you. Notice how the fold lines are placed between views and labeled in Figure 9.11. The front view side of the fold line is labeled F, the side view side is labeled S, and the top view side is labeled T.

**STEP 2** With the corresponding points numbered in each view, draw an auxiliary fold line parallel to the edge view of the slanted surface. The auxiliary fold line can be any convenient distance from the edge view. Your line of sight for the auxiliary view is perpendicular to the edge view of the foreshortened surface. Draw projection lines perpendicular to the fold line to begin creating the auxiliary view. Project the points on the edge view perpendicular (90°) across the auxiliary fold line. Notice how the fold line is placed between the side and auxiliary view and labeled. The side view side of the fold line is labeled S, the auxiliary view side is labeled AUX (see Figure 9.11). The vertical fold line (reference plane) between the front and right views is used to establish the width dimensions (see Figure 9.11).

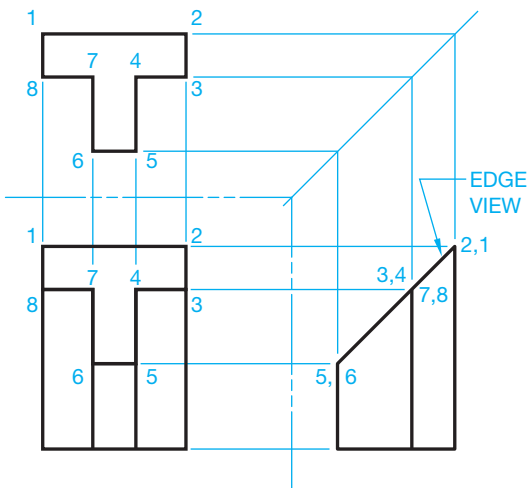


FIGURE 9.10 Step 1: Multiview layout. © Cengage Learning 2012

**STEP 3** Establish the distance to each point from the adjacent view and transfer the distance to the auxiliary view as shown in Figure 9.12a. Sometimes it is helpful to sketch a small pictorial to assist in visualization as shown in Figure 9.12b. You get the true width measurements from either the front or top views. The front view is used, in this example, to get the width measurements in Figure 9.12a. Measure the distance X from the fold line to the front view and the width W in the front view as shown in Figure 9.12a. Connect the points to create the true size and shape of the foreshortened surface, which is the desired auxiliary view you are trying to establish (see Figure 9.12a).

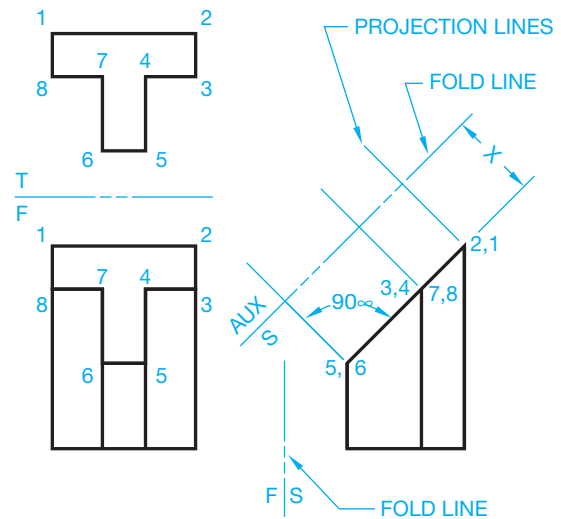


FIGURE 9.11 Step 2: Establish the auxiliary (AUX) fold line.

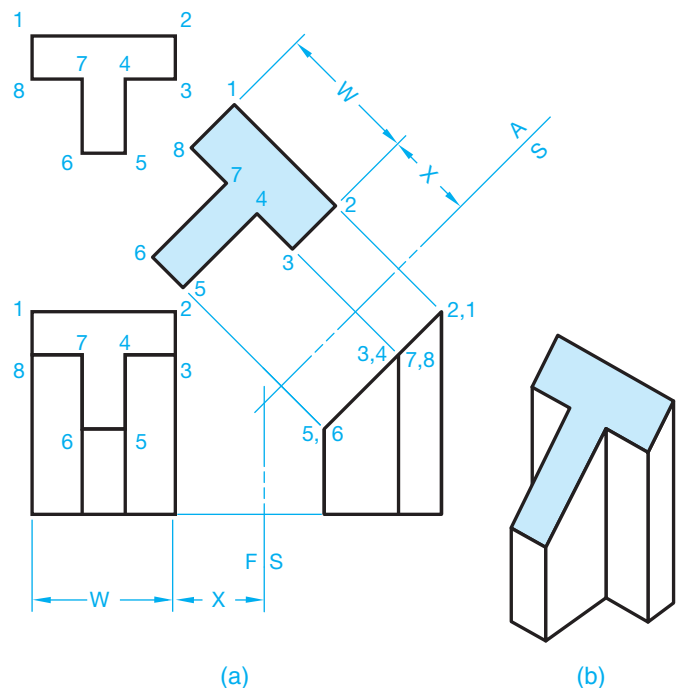


FIGURE 9.12 (a) Step 3: Layout auxiliary view. (b) Pictorial to help visualize object. © Cengage Learning 2012

## DRAWING CURVES IN AUXILIARY VIEWS

Curves are drawn in auxiliary views in the same manner as those shapes described previously, except the process can be more detailed. When corners exist, they are used to lay out the extent of the auxiliary surface. An auxiliary surface with irregular curved contours requires the curve be divided into elements so the element points can be transferred from one view to the next, as shown in Figure 9.13.

The contour of elliptical shapes can be plotted as shown in Figure 9.14. Use a command such as ELLIPSE to set the major and minor diameters followed by picking the center point at the desired ellipse location.

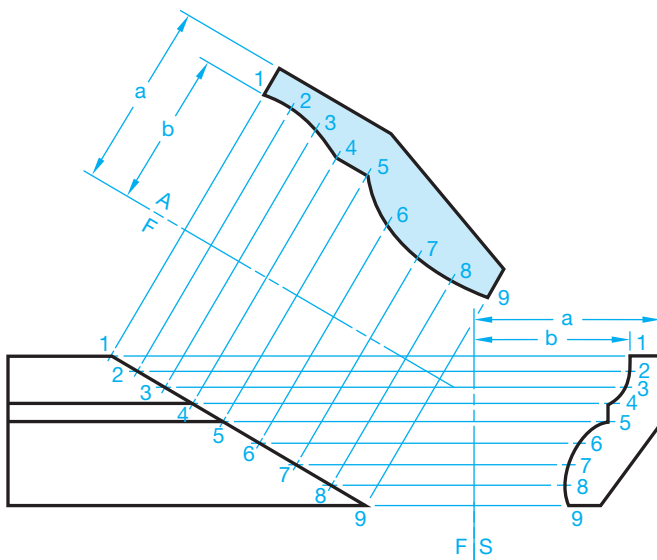


FIGURE 9.13 Plotting curves in auxiliary view. © Cengage Learning 2012

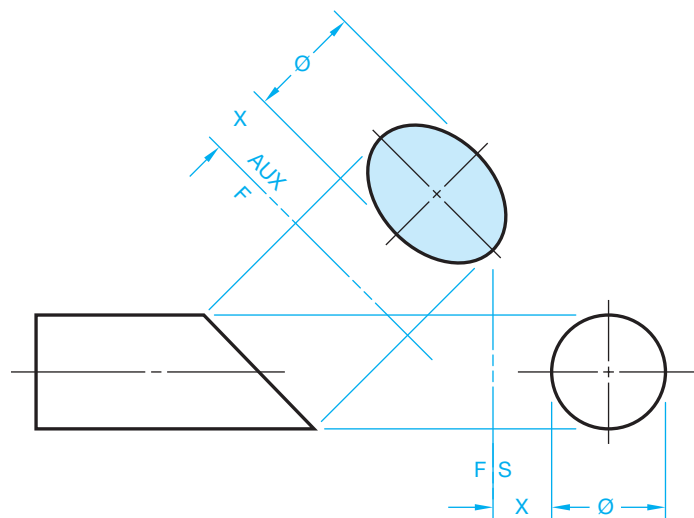


FIGURE 9.14 Elliptical auxiliary view. © Cengage Learning 2012

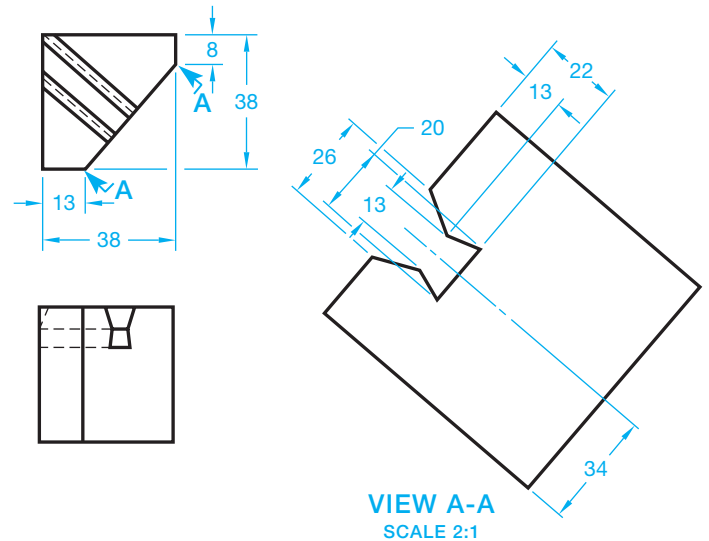


FIGURE 9.15 Auxiliary view enlargement. © Cengage Learning 2012

## VIEW ENLARGEMENTS

In some situations, you may need to enlarge an auxiliary view so small detail can be shown more clearly. Figure 9.18 shows an object with a foreshortened surface. The two principal views are clearly dimensioned at a 1:1 scale. The 1:1 scale is too small to clarify the shape and size of the slot through the part. A viewing-plane line is placed to show the relationship of the principal view to the auxiliary view. The auxiliary view can then be drawn in any convenient location at any desired scale. The auxiliary view in Figure 9.15 is drawn at a 2:1 scale.

## DRAWING A REMOVED AUXILIARY VIEW

When it is not possible to align the auxiliary view directly from the inclined surface, then a viewing-plane line can be used and the view placed in a convenient location on the drawing as shown in Figure 9.16. The viewing-plane line arrowheads maintain the same 3:1 length-to-width ratio as dimension-line arrowheads. Viewing-plane line arrowheads are generally twice the size of dimension-line arrowheads, so they show up better on the drawing. If the dimension-line arrowheads are .125 in. (3 mm) long on your drawing, then make the viewing-plane line arrowheads .25 in. (6 mm) long. This depends on the size of the drawing and your school or company standards. The viewing-plane line is labeled with letters so the view can be clearly identified. This is especially necessary when several viewing-plane lines are used to label different auxiliary views. Place views in the same relationship as the viewing-plane lines indicate and as if the auxiliary view were projected from the slanted surface. Do not rotate the auxiliary. Where multiple views are used, orient views from left to right and from top to bottom. The views are labeled to correlate with their viewing plane, such as VIEW A-A for the first view, VIEW B-B for the second view, and VIEW C-C for the third view. The title VIEW A-A uses a text height of .24 in. (6 mm).



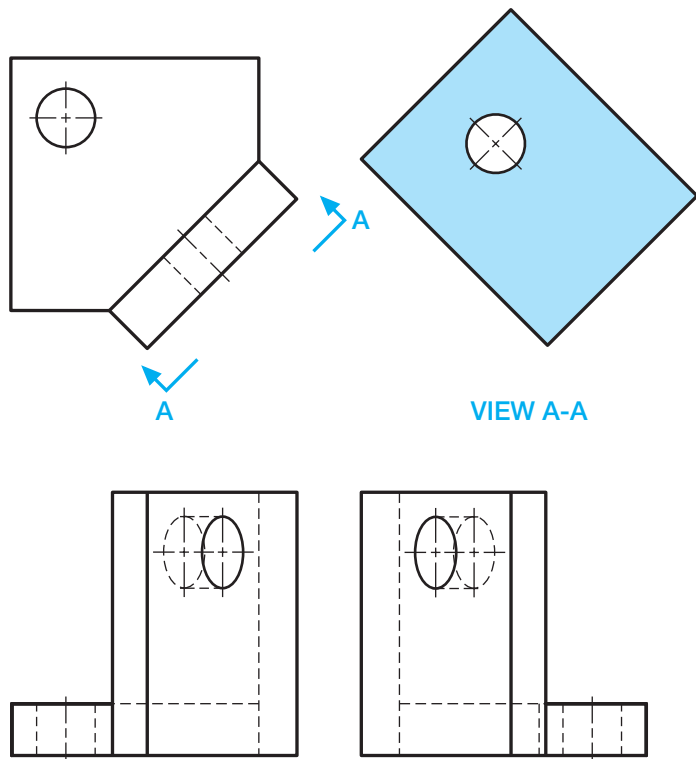


FIGURE 9.16 Establishing auxiliary view with viewing plane. © Cengage Learning 2012

## LOCATING VIEWS ON DIFFERENT SHEETS

This chapter describes the various methods used for displaying viewing-plane lines and related views. The preferred method is to project the auxiliary view directly from a principal view. Alternately, you can place labeled viewing-plane lines where needed and locate the related auxiliary view in another place on the same sheet. When using this method, each auxiliary view has a title correlated to the viewing-plane lines as previously described.

When necessary, locate auxiliary views on a sheet other than where the viewing-plane lines appear. The method for doing this is called **cross-reference zoning**, and it is used to indicate the location of a view back to the viewing location on a previous page. The auxiliary view is located on a different page and is labeled with the sheet number and zone of the cross-reference viewing plane. ASME Y14.3 does not recommend a specific zone and page identification system. The viewing plane and auxiliary views should have a note correlating each between sheets, such as LOCATED ON 2 ZONE B4 next to the viewing plane on the sheet where the viewing plane is located, and SEE SHEET 1 ZONE A5 next to the view on the sheet where the view is located. All sheets of a multiple-sheet drawing should be the same size. Each sheet has the same drawing number or part number. The sheets also have page numbers. For example, if there are three sheets, the first sheet is 1/3, the second sheet is 2/3, and the third sheet is 3/3. The format 1 OF 3, 2 OF 3, and 3 OF 3 can also be used. When a drawing has multiple sheets, the first sheet has the complete title block and other sheet blocks, including the angle of projection block and dimensioning and tolerance block. Additional sheets can have same set of blocks, or they can have a **continuation sheet**

**title block.** The continuation sheet title block uses a minimum of the drawing number, scale, sheet size, CAGE code, and sheet number. Refer back to Chapter 8, Figure 8.36b, where you can see a continuous sheet title block. Any use of this practice should be confirmed with your school or company standards.

## DRAWING A ROTATED AUXILIARY VIEW

It is preferred to align an auxiliary view with its principal view when possible. However, there is an option to rotate an auxiliary view when the normal auxiliary view placement takes up too much space on the sheet. When this is done, a viewing-plane line is used to indicate from where the view is taken, and the auxiliary view is placed in any desired location on the drawing. The auxiliary view is rotated as needed and the angle and direction of rotation is specified under the view title as shown in Figure 9.10. Notice in Figure 9.17 that the specification ROTATED 45° CW is placed under the view title. This means that the auxiliary view is rotated clockwise (CW) from its normal projection plane. If the view were rotated counterclockwise, the abbreviation CCW would have been placed after the rotation specification.

## Using the Reference Arrow and Rotation Arrow Method

An optional reference arrow method can be used to show a removed auxiliary view. This method was introduced into ASME Y14.3 by the International Organization for Standardization (ISO). When this method is used, a viewing arrow with a view identification letter points to the location from where the view is taken. The auxiliary view is then placed in any desired location on the sheet and in the same orientation as the reference arrow. The view identification letter is placed above the auxiliary view as shown in Figure 9.18a. An optional rotation arrow method can be used to show a rotated auxiliary view with the

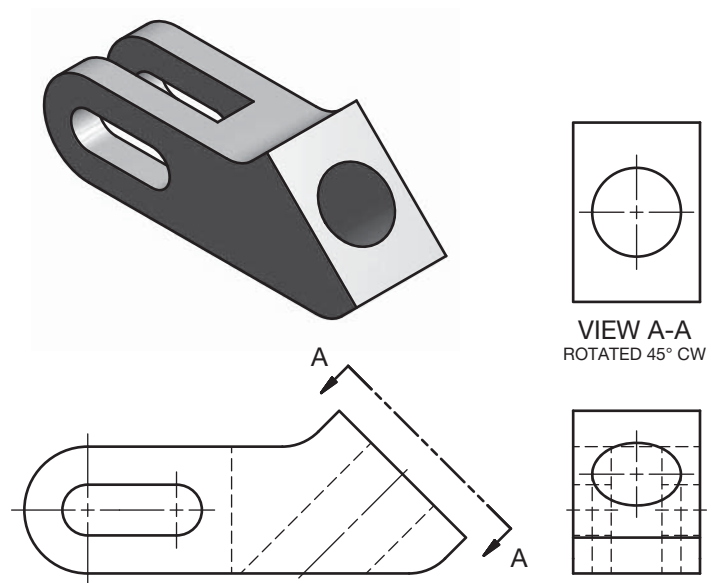
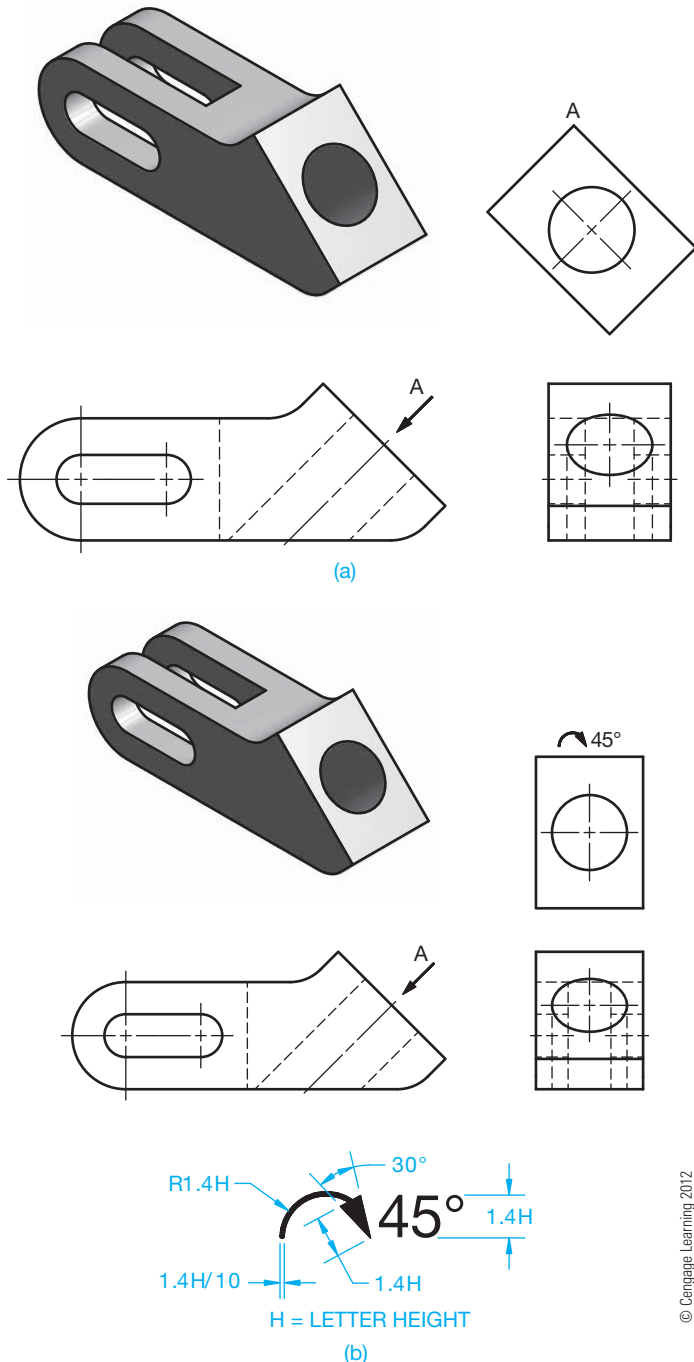


FIGURE 9.17 Establishing a rotated auxiliary view with a viewing-plane line. © Cengage Learning 2012

reference arrow method. When this method is used, a viewing arrow with a view identification letter points to the location from where the view is taken. The auxiliary view is then placed in any desired location on the drawing. The view identification letter, rotation arrow, and degrees of rotation are placed above the auxiliary view as shown in Figure 9.18b. The rotation arrow is also detailed in Figure 9.18b. If the rotation arrow points counterclockwise, the rotation is counterclockwise. The rotation is clockwise if the rotation arrow points clockwise.



**FIGURE 9.18** (a) Establishing an auxiliary view using the arrow method. (b) Establishing a rotated auxiliary view using the arrow method, and the rotation arrow specifications.

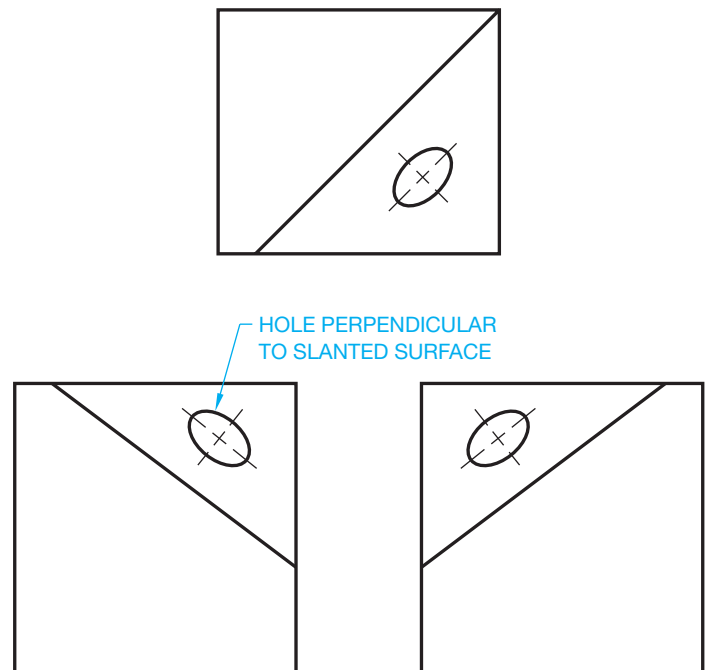
## SECONDARY AUXILIARY VIEWS

The auxiliary views described are called **primary auxiliary views**. Primary auxiliary views are views that are adjacent to and aligned with a principal view. In some situations, a feature of an object is in an **oblique** position in relationship to the principal planes of projection. The term *oblique* means that the feature is inclined, slanted, or sloped in the principal view. These inclined or slanting surfaces do not provide an edge view in any of the six possible multiviews. The inclined surface in Figure 9.19 is foreshortened in each view, and an edge view does not exist. From the discussion on primary auxiliary views, you realize that projection must be from an edge view to establish the auxiliary view.

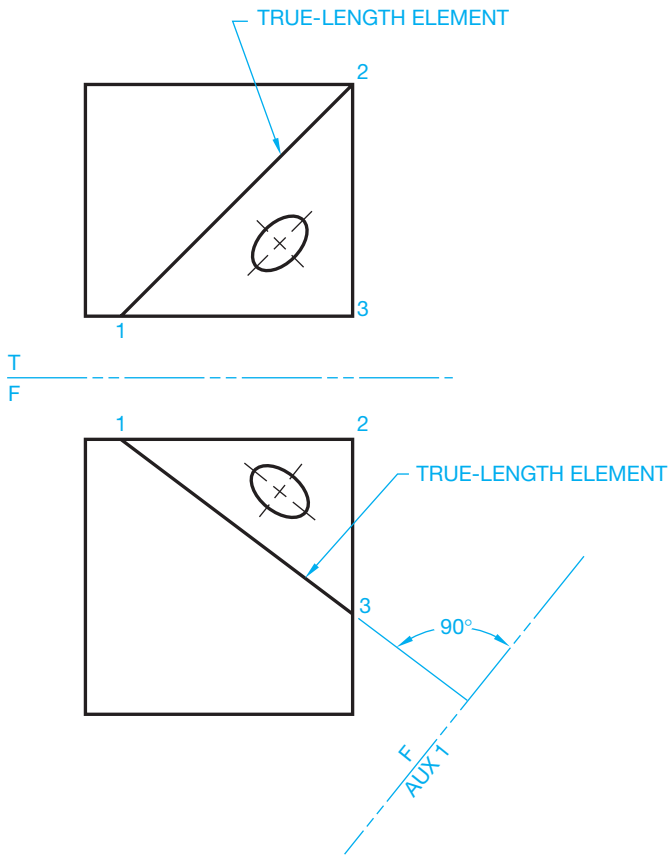
To obtain the true size and shape of the inclined surface in Figure 9.19, a **secondary auxiliary view** is needed. A secondary auxiliary view is projected from a primary auxiliary view. Secondary auxiliary view is defined as a view that is adjacent to and projected from a primary auxiliary view or from another secondary auxiliary view. The following steps can be used to prepare a secondary auxiliary view:

**STEP 1** Only two principal views are necessary to use when creating a secondary auxiliary view because the third principal view does not add additional information. Establish an element in one view that is in true length, as shown in Figure 9.20. Label the corners of the inclined surface and draw a fold line perpendicular to the true-length elements. *Note:* You know a line is in true length when the adjacent view of the line is parallel to the fold line. Look at line 1,3 in Figure 9.20. Line 1,3 is parallel to the fold line in the top view. This makes line 1,3 true length in the front view.

**STEP 2** The purpose of this step is to establish a primary auxiliary view that displays the slanted surface as an edge



**FIGURE 9.19** Oblique surface. There is no edge view in the principal views. This requires a secondary auxiliary view. © Cengage Learning 2012



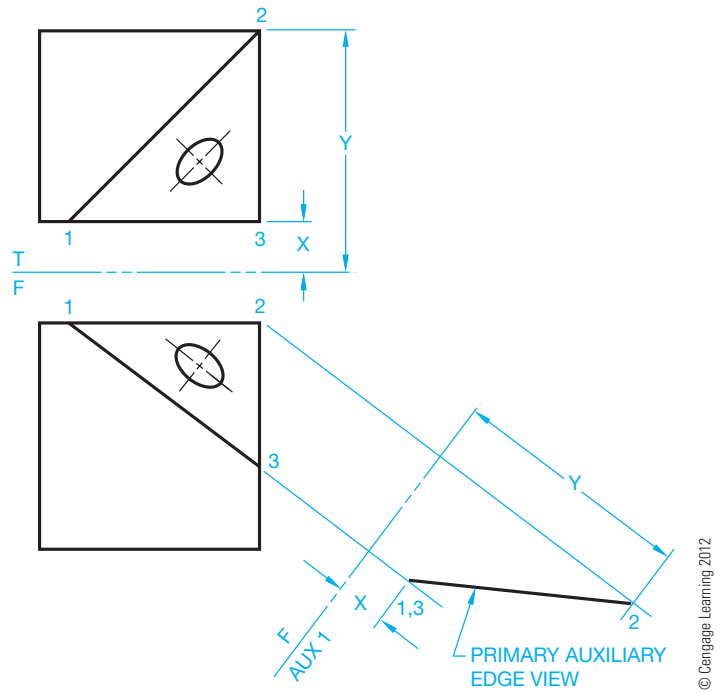
**FIGURE 9.20** Step 1: Draw a fold line perpendicular to the true-length element. © Cengage Learning 2012

view. Project the slanted surface onto the primary auxiliary plane as shown in Figure 9.21. This results in the inclined surface appearing as an edge view or line in the primary auxiliary view.

**STEP 3** Now, with an edge view established, the next step is the same as the normal auxiliary view development. Draw a fold line parallel to the edge view. Project points from the edge view perpendicular to the secondary fold line to establish points for the secondary auxiliary view as shown in Figure 9.22. In Figure 9.22, the primary auxiliary view established corners of the inclined surface as a line or edge view. This edge view is necessary; the perpendicular line of projection for the secondary auxiliary helps establish the true size and shape of the surface.

### Using a Primary Auxiliary View in Place of a Principal View

Previously, only the edge view of the inclined surface was shown in the primary auxiliary view. This was because showing the entire object in that view would not have added any clarity to the drawing. The only purpose for the primary auxiliary view was to establish the true geometry in the secondary auxiliary view. In many situations, both the primary and secondary auxiliary views are used to establish the relationship between features of the object. In Figure 9.23, the primary auxiliary view shows the relationship of the inclined feature to the rest of the part, and the secondary auxiliary



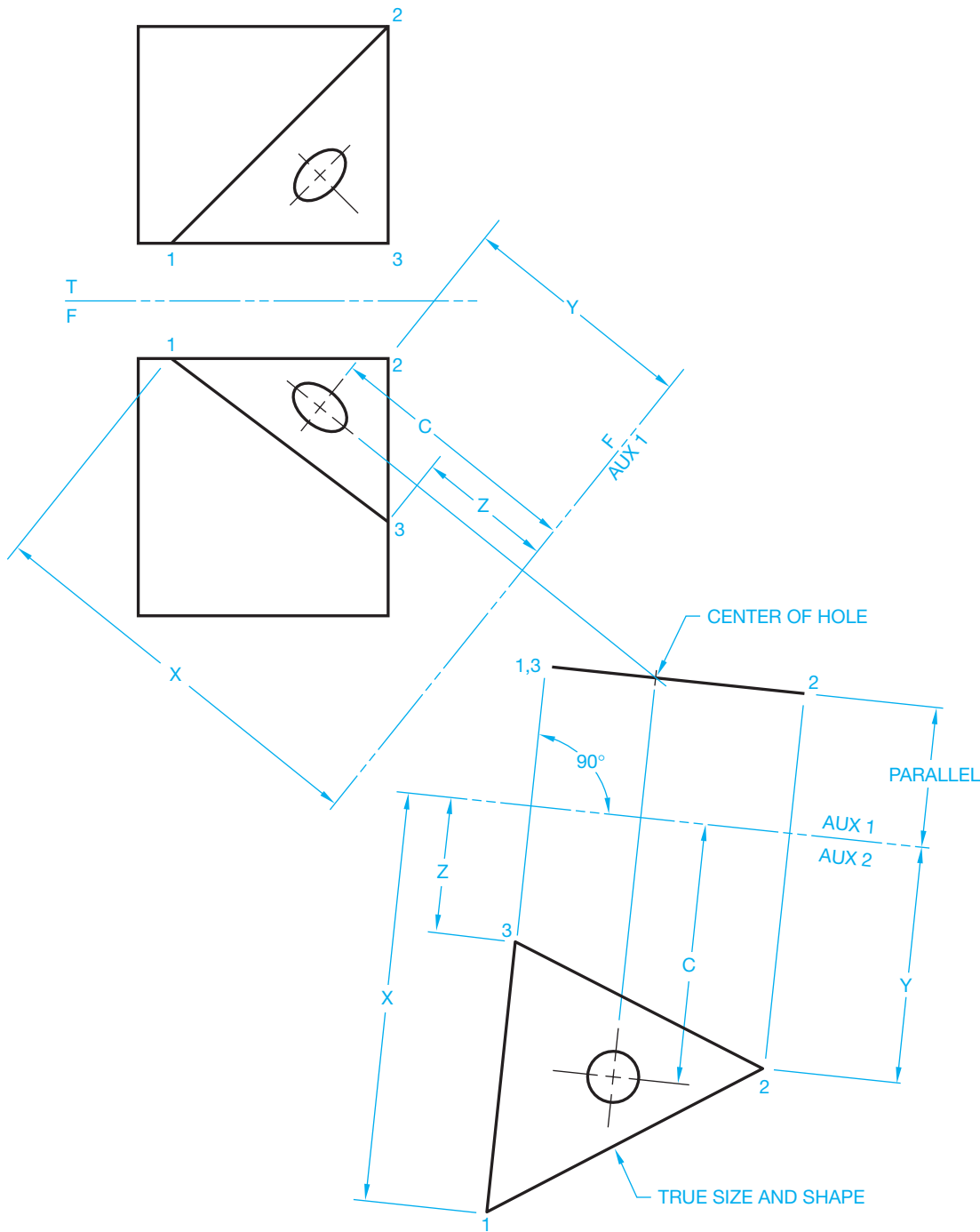
**FIGURE 9.21** Step 2: Primary auxiliary edge view of oblique surface.

view shows the true size and shape of the inclined features plus the true location of the holes. In this application, the primary auxiliary view is much like a principal view because it shows height dimensions and the true angle relationship between features on the part.

### AUXILIARY VIEW ANALYSIS AND REVIEW

The following is a review covering the features and importance of using multiviews, auxiliary views, and orthographic projection:

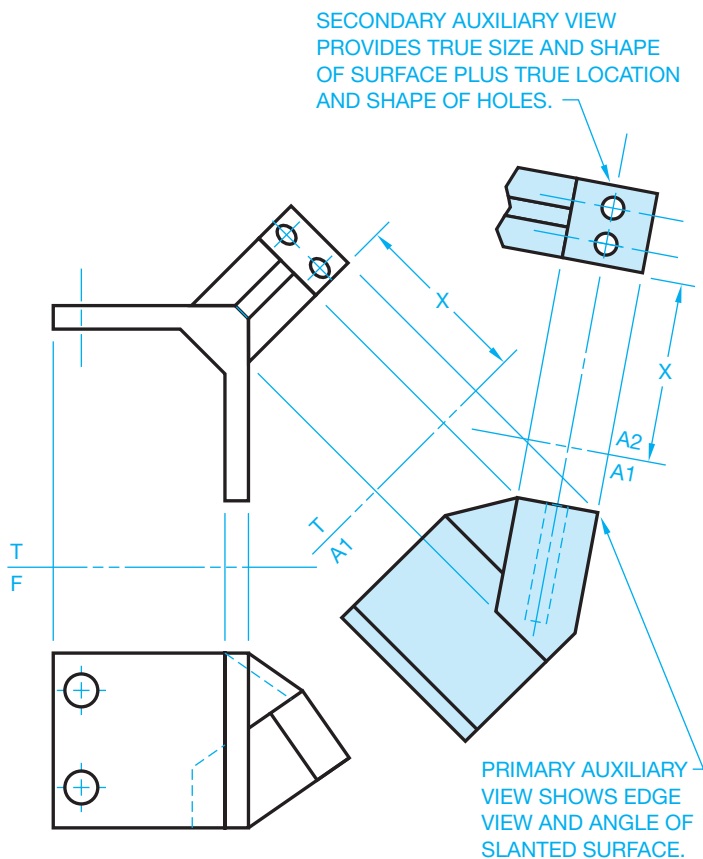
- The multiview system, including auxiliary views, is covered in the ASME Y14.3 standard.
- The two internationally accepted view projection systems are third-angle and first-angle projection. Both systems are discussed in this chapter, and third-angle projection is used throughout this textbook.
- Multiview drawings represent the shape of an object using two or more views, and there are six principal views: front, top, right side, left side, bottom, and rear.
- All views are aligned in either third-angle projection or first-angle projection, and the appropriate third- or first-angle projection symbol should be placed on the drawing.
- Adjacent views must be aligned, unless otherwise specified.
- Related views must be aligned, unless otherwise specified.
- There is always one dimension that is the same between adjacent views.
- The front view is normally considered the most important view from which other views are established.
- The number of required views varies, depending on the complexity of the object, and views must be selected to completely describe the shape and features on the object.
- A line in a view is in true length when the line is parallel to the projection plane.



© Cengage Learning 2012

**FIGURE 9.22** Step 3: Secondary auxiliary projected from the edge view to get the true size and shape of the oblique surface.

- A surface of a view is in true size and shape when the surface is parallel to the projection plane.
- A line in a view is foreshortened when the line is not parallel to the projection plane.
- A surface of a view is foreshortened when the surface is not parallel to the projection plane.
- Auxiliary views are used to show the true size, shape, and relationship of features of a surface that is not parallel to any of the principal planes of projection.
- A primary auxiliary view is one that is adjacent to and aligned with a principal view.
- A secondary auxiliary view is one that is adjacent to and aligned with a primary auxiliary view or with another secondary auxiliary view.
- Additional view placement options are discussed in this chapter and in Chapter 8 and include: removed views, rotated views, and detail views. Use of these options should be confirmed with your school or company practices.



**FIGURE 9.23** Creating primary and secondary auxiliary views. © Cengage Learning 2012

## DESCRIPTIVE GEOMETRY

Descriptive geometry, covered in detail in Student CD, is used for determining issues such as finding the true lengths of lines, the end view of a line, the true size and shape of a surface or plane, the angle between two lines, the angle between two planes, the intersection between two planes, and the intersection between a cone or a cylinder and a plane. Descriptive geometry problems are solved graphically by projecting points onto selected adjacent projection planes in an imaginary projection system. The multiview and auxiliary view concepts you learned in Chapter 8 and in this chapter serve as a basis for further study of descriptive geometry concepts. What you have learned in these two chapters, coupled with what you will learn in the descriptive geometry content, will help you solve additional drafting problems as you study advanced chapters covering specialty drafting fields and problems you encounter in industry.



### Descriptive Geometry

For complete information about Descriptive Geometry, go to the Student CD, select **Reference Material**, and then **Descriptive Geometry I** and **Descriptive Geometry II**.

## AUXILIARY VIEW LAYOUT

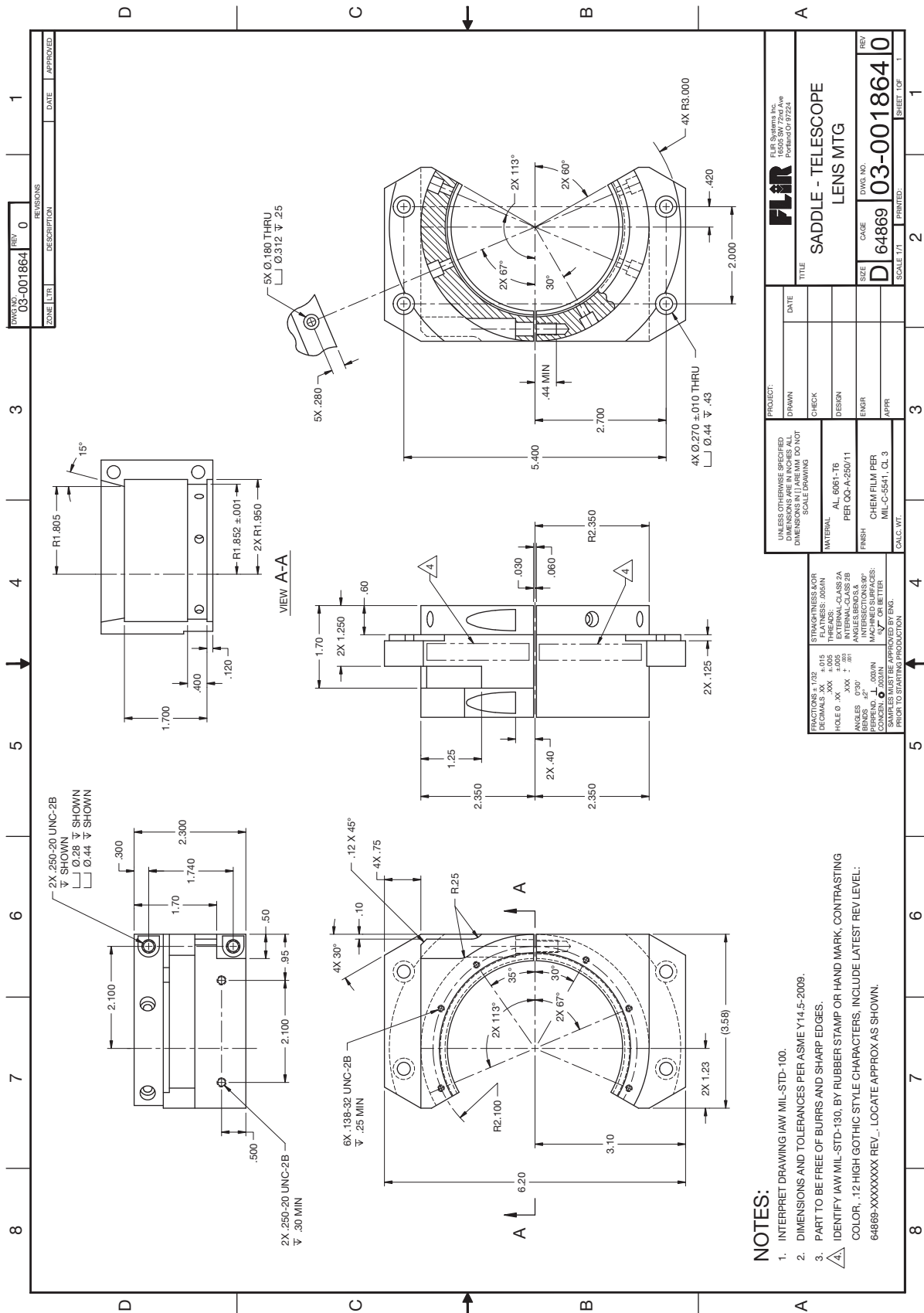
Working with auxiliary views is a little more complex than working with the normal multiviews. The auxiliary view is often difficult to place in relationship to the other views. Sheet size requirements can cause the auxiliary view to interfere with other views. Whenever possible, it is best to project the auxiliary view directly from the inclined surface with one projection line connecting the inclined surface to the auxiliary view. This arrangement makes it easier for the reader to correctly interpret the relationship of the views. This method is shown in the layout steps provided in Figure 9.13 through Figure 9.15.

When drawing space is limited, it is possible to use the viewing-plane method or the rotated view method to display the auxiliary view. These techniques are shown in Figure 9.9 through Figure 9.11. The advantage of the viewing-plane method is that it allows you to place the auxiliary view in any convenient place on the drawing. Multiple auxiliary views should be placed in a group arranged from right to left and from top to bottom on the drawing. A poor practice sometimes used by entry-level drafters is to place viewing planes all over the drawing and shift views from their normal position. This practice should be avoided because the normal multiview projection is always best. You should follow the layout procedure described in Chapter 8 for multiviews and for auxiliary views described in this chapter.

The following steps summarized creating a multiview and an auxiliary view layout:

- Select and sketch the front view.
- Select and sketch the other principal views in proper relationship to the front view, eliminating any unnecessary views.
- Sketch the auxiliary view or views in their proper positions.
- Establish the sheet size and the working area to be used.
- Determine the approximate total drawing area.
- Lay out the views using construction lines.
- Complete the formal drawing.

Instruction on the development of views often focuses on the use of three views, such as a front, top, and side view or a front, top, and auxiliary view. Although this view orientation is common, the actual view selection depends entirely on the part you are drawing. Many parts can require a number of views that can include several multiviews and an auxiliary view. The combination of views can even include a sectional view. Section views are covered in detail in Chapter 12. Spend some time looking at as many real-world drawings as you can find. You may discover that some actual industry drawing could be done in a different manner and that you might have ideas for improving the way drawings are done. This is your challenge as you begin to create your own drawings. The actual industry drawing shown in Figure 9.24 shows a front view, top view, right-side view, VIEW A–A created with a viewing plane, a broken-out sectional view, and a partial auxiliary view projected from the sectional view. This example demonstrates the complexity of some drawings.

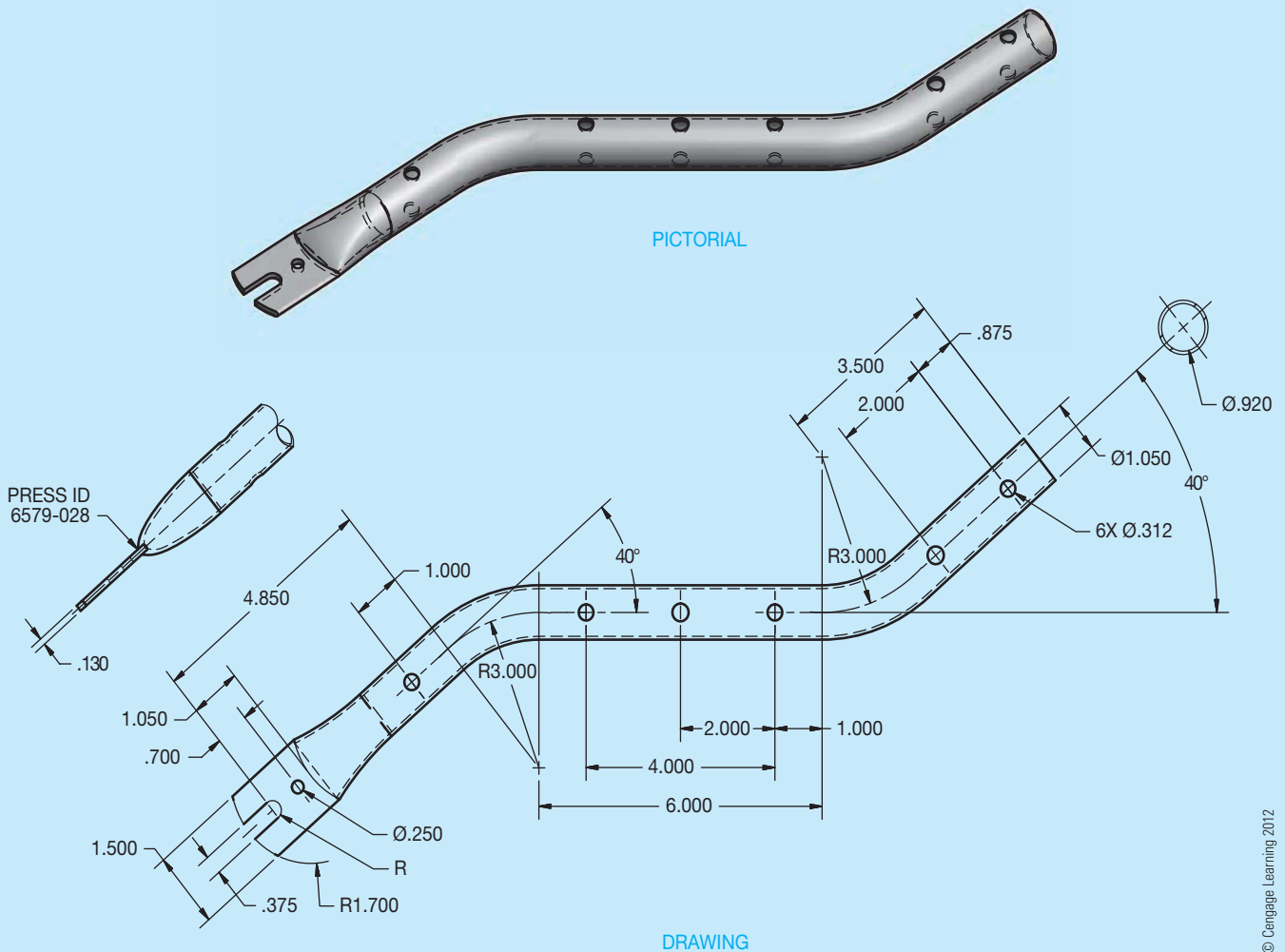


**FIGURE 9.24** A complex part displayed on the drawing using several carefully selected views including a front, top, and right-side view; a view created from a viewing plane; a sectional view; and an auxiliary view. Courtesy FLIR Systems

## DRAWING ACCURACY

One important aspect of CADD technology is accuracy. Multiview and auxiliary view drawings produced with CADD should be perfect if you use appropriate CADD techniques and follow correct drafting standards throughout the drawing process. The reason for high accuracy involves the capabilities of computer hardware and software and the fact that the computer displays the mathematical counterpart of the true geometry. Drawing views are a representation of the mathematical coordinates of the design problem. Therefore, the accuracy potential of the computer controls drawing accuracy.

Figure 9.25 shows an example of a drawing of a tubular mainframe part. A front view and two partial auxiliary views represent the part completely. CADD offers tools and options that allow you to construct the geometry of the front view quickly and accurately. You can then easily project the auxiliary views from the inclined surfaces using a viewing plane exactly perpendicular to the inclined surfaces. The final step is to add dimensions associated with view objects. The computer stores data about each object. Any changes you make to the drawing update in the associated views and dimensions.



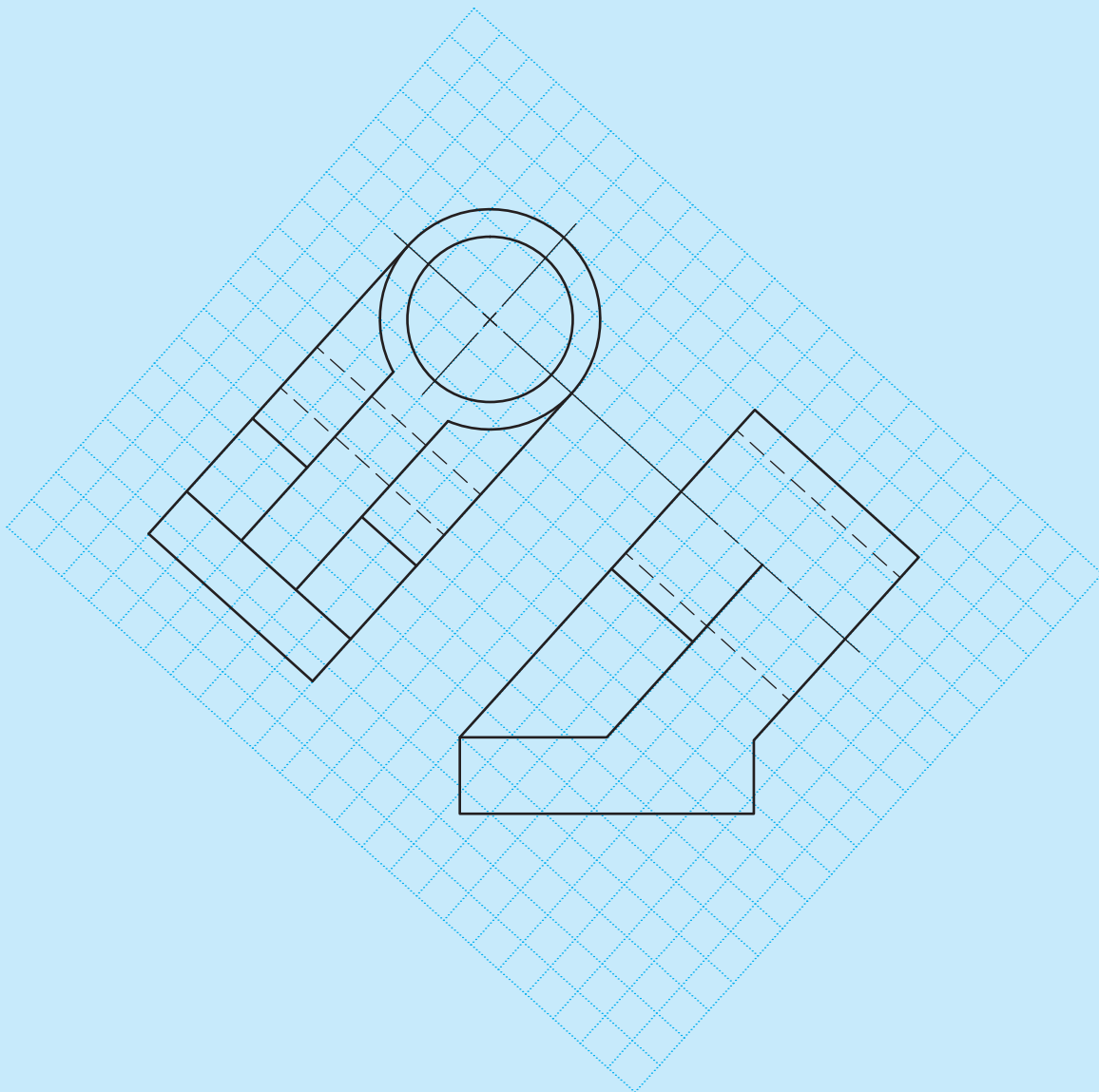
**FIGURE 9.25** An example of a part with a front view and two auxiliary views.

## AUXILIARY VIEW CONSTRUCTION

The process of construction auxiliary views using 2-D drafting software is similar to drawing principal multiviews. The main difference is you must account for a viewing plane that is perpendicular to inclined surfaces. Most 2-D drafting applications include functions for accurately defining object points using coordinate point entry methods and basic drawing aids such as grid lines and grid snaps. You can also develop auxiliary views using common construction geometry or specific

software drawing aids, such as AutoCAD's object snap and AutoTrack tools.

Figure 9.26 shows an example of using on-screen grid rotated to the same angle as the inclined surface from which the auxiliary view projects. The grid is a drawing aid for development purposes only and may display as dots or as the lines shown. The grid does not plot and can be turned off when no longer needed. Figure 9.27 shows another method of projecting the auxiliary view. This example uses infinite length construction lines drawn perpendicular to the inclined surface. Construction lines are objects in the drawing and can be reused for future

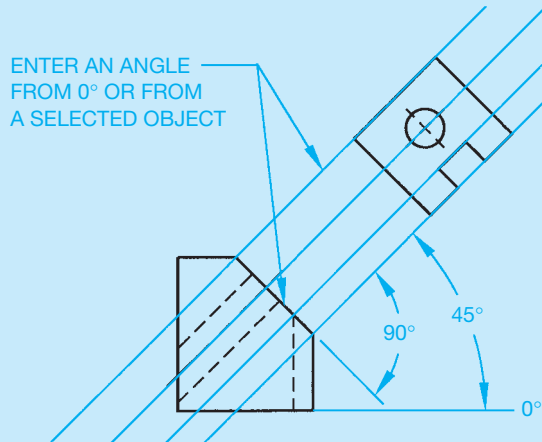


**FIGURE 9.26** Using the rotated on-screen grid to help draw the auxiliary view.

© Cengage Learning 2012

(Continued)



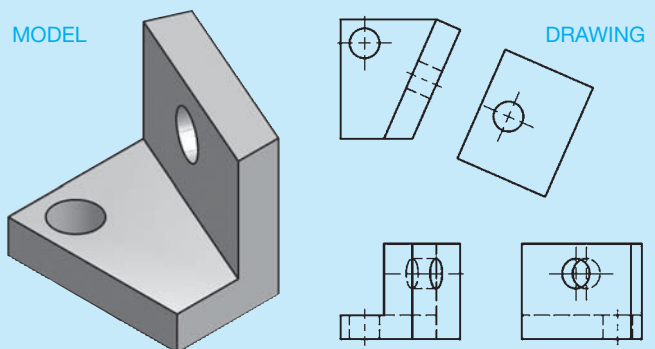


**FIGURE 9.27** Laying out an auxiliary view using construction lines perpendicular to the inclined surface. © Cengage Learning 2012

layout, hidden by freezing or turning off a dedicated construction layer, or removed using a DELETE or ERASE command. Several other techniques for constructing auxiliary views may be possible, depending on the software. For example, AutoCAD's object snap and AutoTrack tracking allow you to locate points on the auxiliary view by referencing points on the existing view, perpendicular to the inclined surface. This process mimics accurate construction lines, without you having to spend time drawing additional objects.

## AUXILIARY VIEWS

The parametric 2-D drawing capabilities of some 3-D solid modeling programs allow you to easily produce a variety of drawing views, including auxiliary views. Tools such as AUXILIARY VIEW allow you to create an auxiliary view by referencing an existing drawing view to parametrically associate a view with the model (see Figure 9.28). Using a tool like AUXILIARY VIEW typically involves selecting an existing drawing view with the inclined surface from which the auxiliary view will project and then picking the edge of the inclined surface and specifying a location for the auxiliary view. You can also choose to add auxiliary view information, such as a view label, by selecting the appropriate options. Often when you create an auxiliary view, all object geometry located on and beyond the selected inclined surface projects onto the auxiliary view plane. This means that you may be required to hide or turn off the visibility of certain, foreshortened edges to create a partial auxiliary view as shown in Figure 9.28.



**FIGURE 9.28** CADD tools such as AUXILIARY VIEW allow you to create an auxiliary view by referencing an existing drawing view, which parametrically associates a view with the model. © Cengage Learning 2012

## PROFESSIONAL PERSPECTIVE

For many people, one of the most difficult aspects of engineering drafting is the need to visualize two-dimensional views. This special ability is natural for some, whereas others must carefully analyze every part of a multiview and auxiliary view drawing in order to fully visualize the product. Ideally, you should be able to look at the views of an object and readily formulate a pictorial representation in your mind. The main reason that multiviews are aligned is to assist in the visualization and interpretation process. The front view is the most important view, and that is why it contains the most significant features. As you look at the front view, you should be able to gain a lot of information about the object

then visually project from the front view to other views to gain an understanding of the entire product.

It is up to you to select the best views to completely describe the object. Too few views make the object difficult or impossible to interpret, and too many views make the drawing too complex and also waste valuable drafting time. If you follow the guidelines set up in this chapter, you should be able to successfully complete the task. Remember, always begin with a sketch. With the sketch, you can quickly determine view arrangement and spacing. Without the preliminary sketch, you might use a lot of drafting time and end up discovering that the layout does not work as you expected.

### PROJECTED AREA

**Problem:** Suppose the steel plate in the shape of an ellipse with an area of  $65.98 \text{ ft}^2$  (from the Math Application in Chapter 8) is set at a  $60^\circ$  angle on the ground. With the sun overhead, what is the area of the *shadow* of the plate on the ground? (See Figure 9.29.)

**Solution:** The shadow's area is called the *projected area* in math. It is found by multiplying the true area by the *cosine* of the inclined angle. Using a calculator,  $\cos 60^\circ = .5$ , so the area of the shadow is  $65.98 \times .5 = 32.99$  or  $33 \text{ ft}^2$ . The principle of multiplying true area by cosine to obtain projected area applies to all 2-D shapes. Math Applications in later chapters further explore right triangles and trigonometry functions, such as cosine.

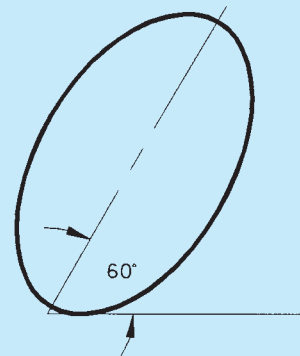


FIGURE 9.29 Tilted ellipse. © Cengage Learning 2012

### WEB SITE RESEARCH

Use the following Web sites as a resource to help find more information related to engineering drawing and design and the content of this chapter.

Address	Company, Product, or Service
<a href="http://www.asme.org">www.asme.org</a>	American Society of Mechanical Engineers (ASME)
<a href="http://www.iso.org">www.iso.org</a>	International Organization for Standardization
<a href="http://www.adda.org">www.adda.org</a>	American Design Drafting Association and American Digital Design Association (ADDA International)

## Chapter 9 Auxiliary Views Test

To access the Chapter 9 test, go to the Student CD, select **Chapter Tests and Problems**, and then **Chapter 9**. Answer the questions

with short, complete statements, sketches, or drawings as needed. Confirm the preferred submittal process with your instructor.

## Chapter 9 Auxiliary Views Problems

### Parts 1, 2, and 3: Problems 9.1 Through 9.14

To access the Chapter 9 problems, go to the Student CD, select **Chapter Tests and Problems** and **Chapter 9**, and then open the problem of your choice or as assigned by your instructor. Solve the problems using the instructions provided on the CD, unless otherwise specified by your instructor.

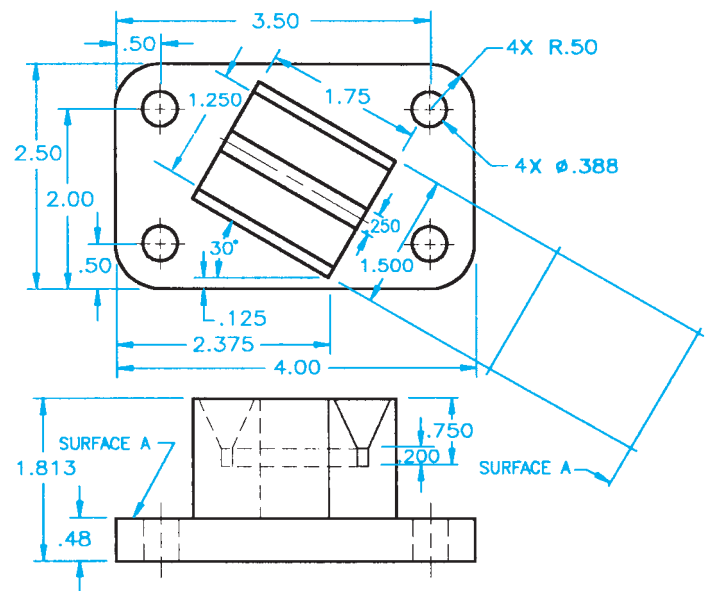
### Part 4: Problem 9.15

This problem provides you with dimensioned pictorial views and a proposed start for your multiview and auxiliary view layout. Draw the required multivIEWS and auxiliary views. Use the given dimensions to create your final drawing. Set up your drawings with a properly sized sheet, border, and sheet block. Properly complete the information in the title block. Do not draw the pictorial view unless required by your instructor. Do not draw the dimensions.

### PROBLEM 9.15 Primary auxiliary view (in.)

Title: Angle V-block

Material: SAE 4320



© Cengage Learning 2012

### Part 5: Problems 9.16 Through 9.24

The following problems provide you with pictorial views that contain dimensions and a recommended view layout. Draw the views. The pictorial views are provided to aid in visualization and to display the dimensions. You do not need to draw the pictorial view. Use the given dimensions to create your final drawing. Set up your drawings with a properly sized sheet, border, and sheet block. Properly complete the information in the title block. Do not draw the dimensions.

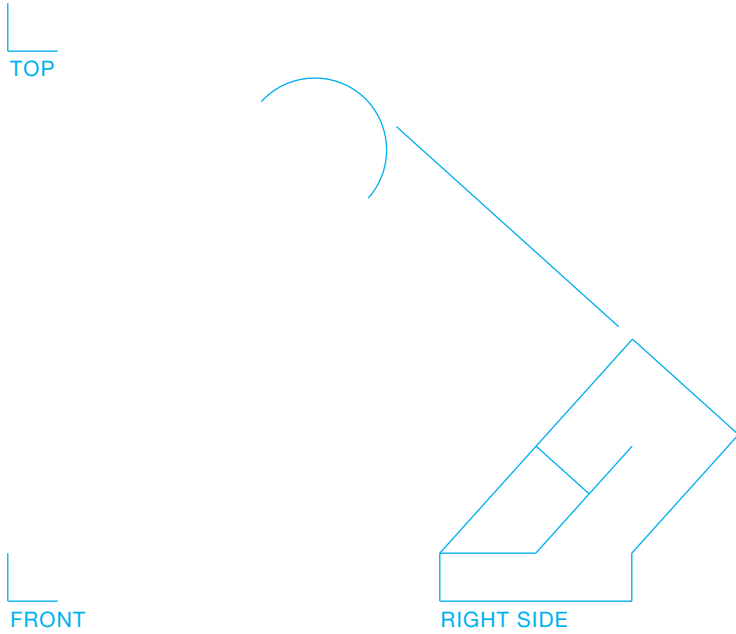
## Drafting Templates

To access CADD template files with predefined drafting settings, go to the Student CD, select **Drafting Templates**, and then the appropriate template file. Use the templates to create new designs, as a resource for drawing and model content, or for inspiration when developing your own templates. The ASME-Inch and ASME-Metric drafting templates follow ASME, ISO, and related mechanical drafting standards. Drawing templates include standard sheet sizes and formats and a variety of appropriate drawing settings and content. You can also use a utility such as the AutoCAD DesignCenter to add content from the drawing templates to your own drawings and templates. Consult with your instructor to determine which template drawing and drawing content to use.

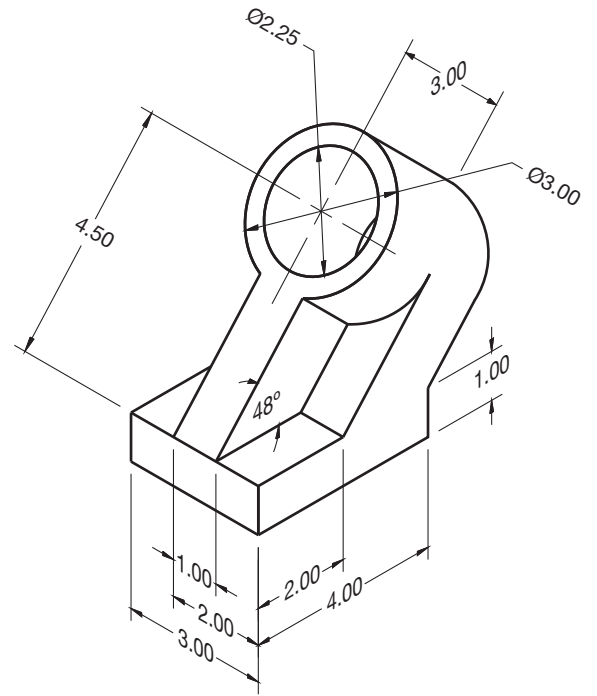
**PROBLEM 9.16 Primary auxiliary view (in.)**

Title: Cylinder Support

Material: Cast iron



SUGGESTED VIEW LAYOUT

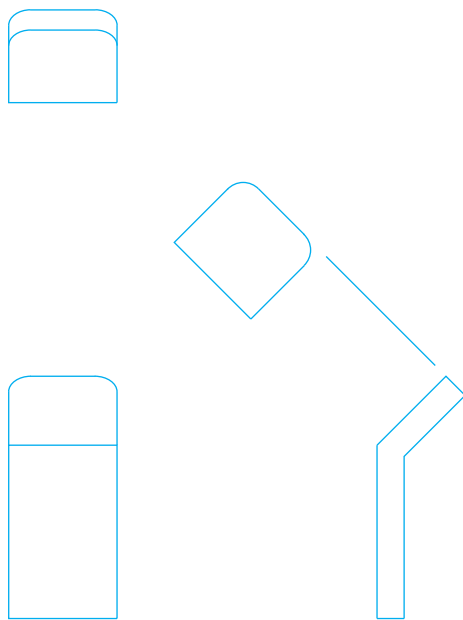


© Cengage Learning 2012

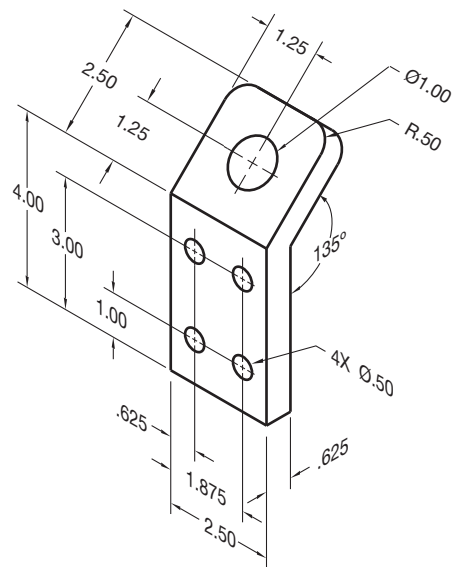
**PROBLEM 9.17 Primary auxiliary view (in.)**

Title: 135 Bracket

Material: Aluminum



SUGGESTED VIEW LAYOUT

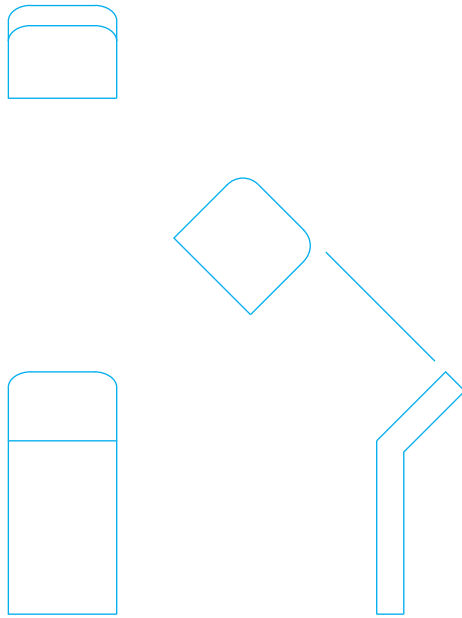


© Cengage Learning 2012

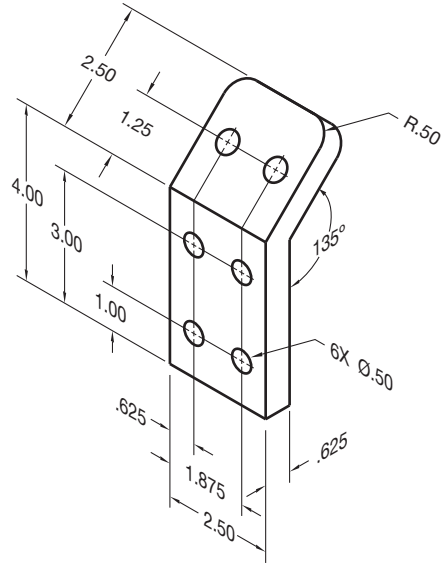
PROBLEM 9.18 Primary auxiliary view (in.)

Title: 135-1 Bracket

Material: Aluminum



SUGGESTED VIEW LAYOUT

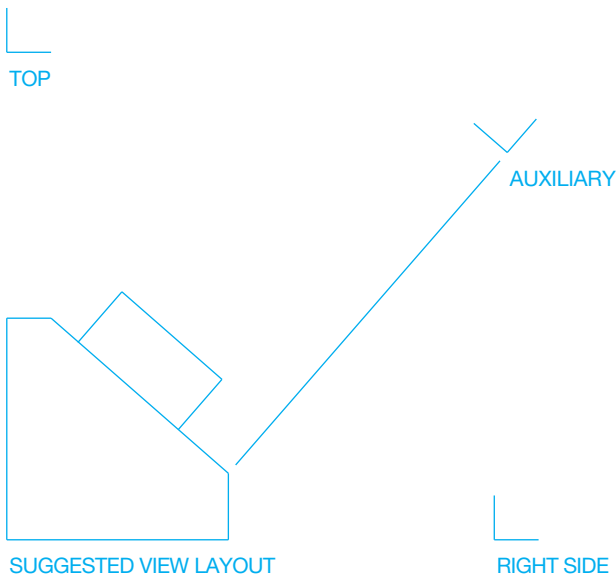


© Cengage Learning 2012

PROBLEM 9.19 Primary auxiliary view (in.)

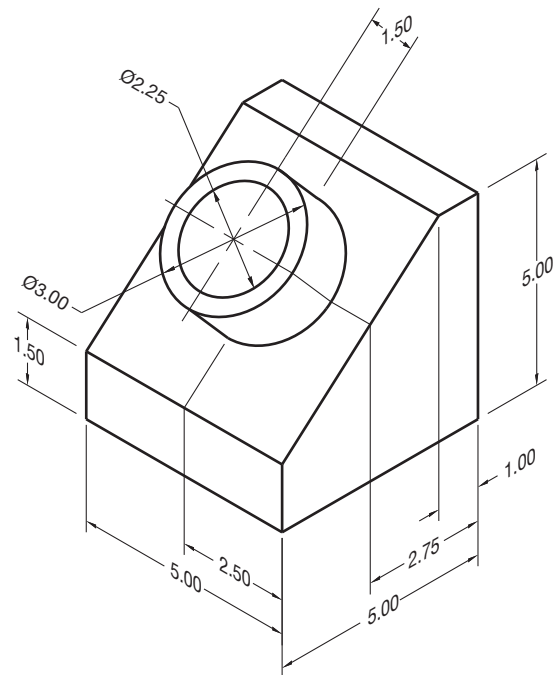
Title: Support Base

Material: Cast aluminum



SUGGESTED VIEW LAYOUT

RIGHT SIDE

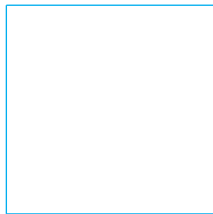
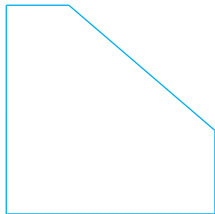
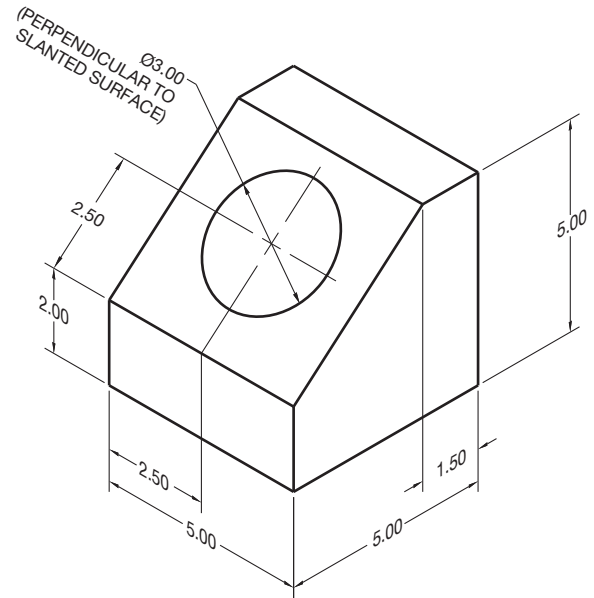


© Cengage Learning 2012

**PROBLEM 9.20 Primary auxiliary view (in.)**

Title: Shaft Support

Material: SAE 1020



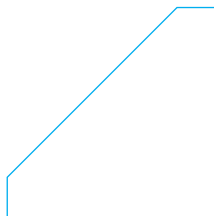
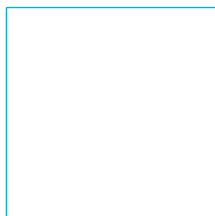
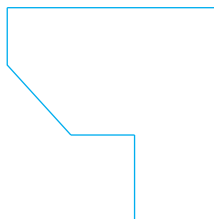
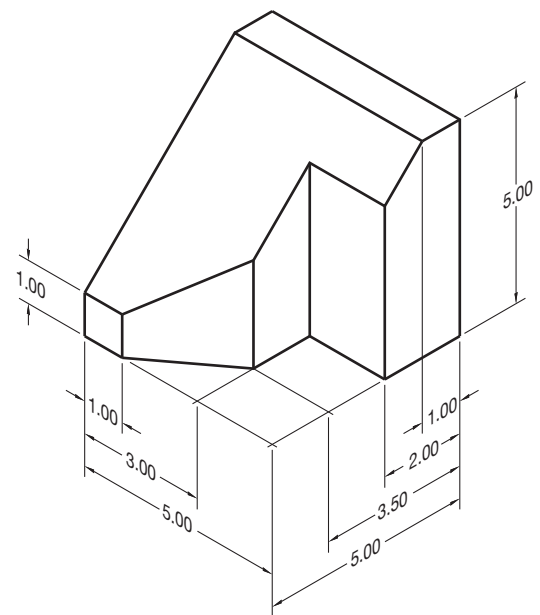
SUGGESTED VIEW LAYOUT

© Cengage Learning 2012

**PROBLEM 9.21 Primary auxiliary view (in.)**

Title: Spacer

Material: Cast iron



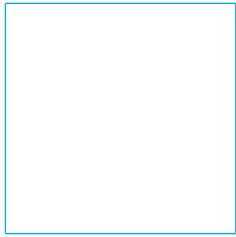
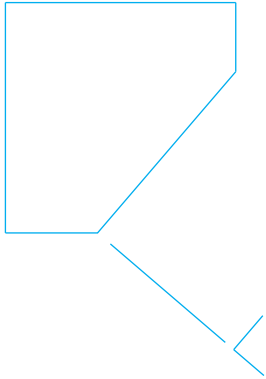
SUGGESTED VIEW LAYOUT

© Cengage Learning 2012

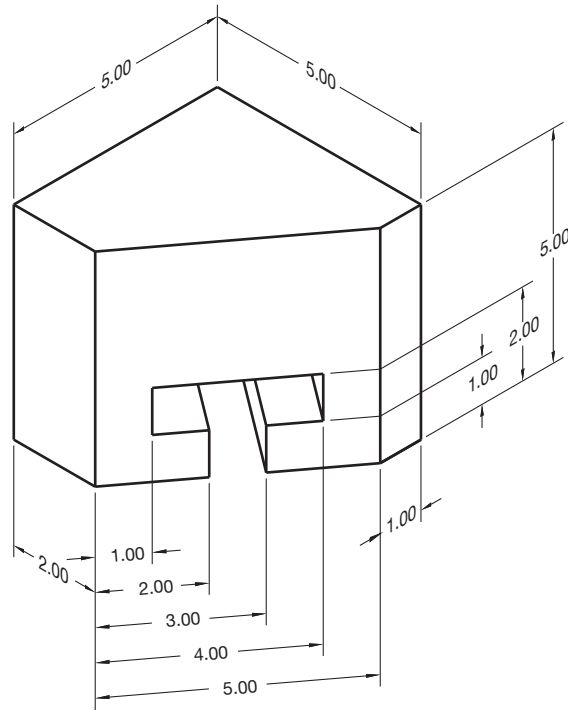
**PROBLEM 9.22 Primary auxiliary view (in.)**

Title: T-Block

Material: SAE 4320



SUGGESTED VIEW LAYOUT

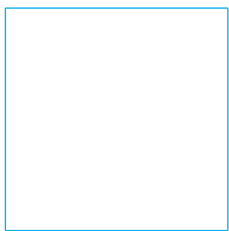
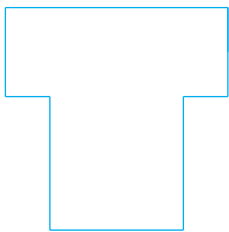


© Cengage Learning 2012

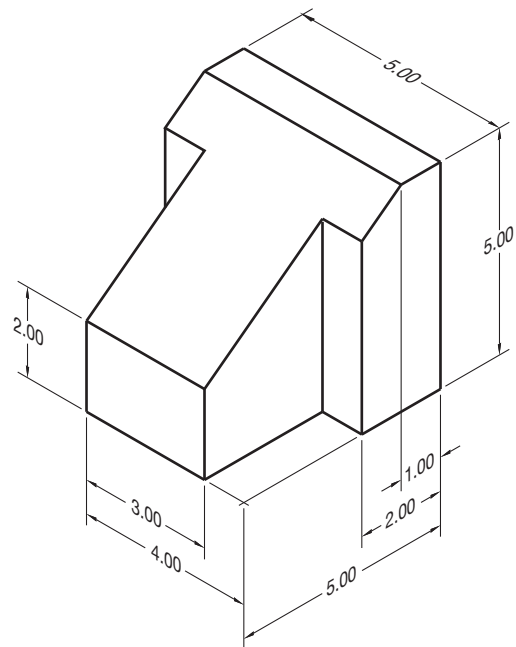
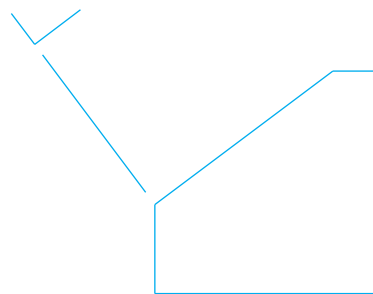
**PROBLEM 9.23 Primary auxiliary view (in.)**

Title: T-Wedge

Material: Mild steel



SUGGESTED VIEW LAYOUT

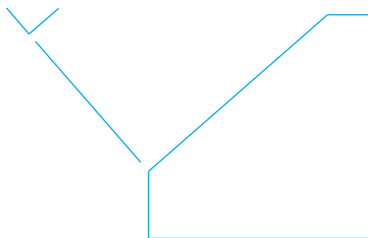
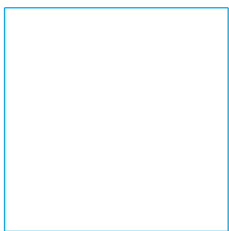
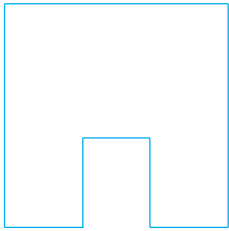


© Cengage Learning 2012

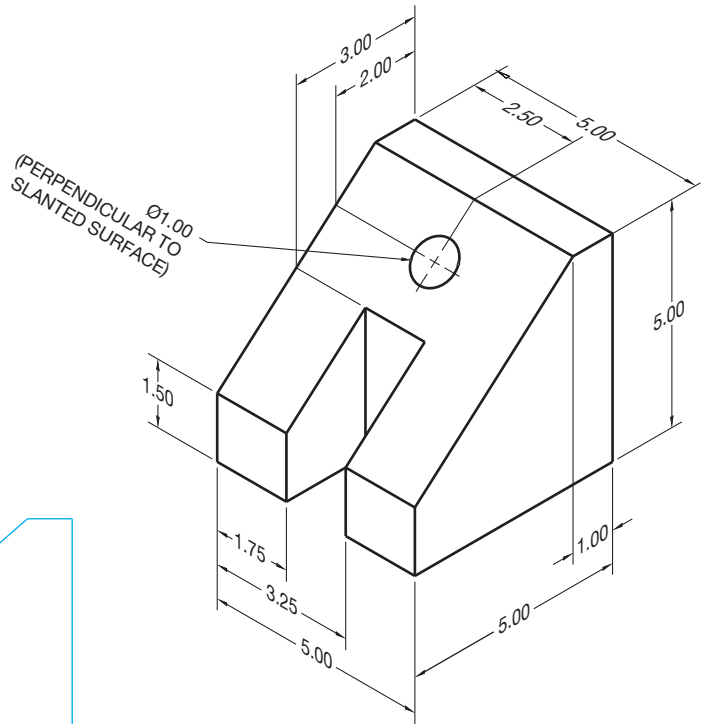
**PROBLEM 9.24 Primary auxiliary view (in.)**

Title: Brace

Material: Cast iron



SUGGESTED VIEW LAYOUT



© Cengage Learning 2012

**Part 6: Problems 9.25 Through 9.37**



To access the Chapter 9 problems, go to the Student CD, select **Chapter Tests and Problems** and **Chapter 9**, and then open the problem of your choice or as assigned by your instructor. Solve the problems using the instructions provided on the CD, unless otherwise specified by your instructor.

**Part 7: Problems 9.38 and 9.39**

The following problems provide you with pictorial views that contain dimensions and a recommended view layout. Draw the views. The pictorial views are provided to aid in visualization and to display the dimensions. You do not need to draw the pictorial view. Use the given dimensions to create your final drawing. Set up your drawings with a properly sized sheet, border, and sheet block. Properly complete the information in the title block. Do not draw the dimensions.

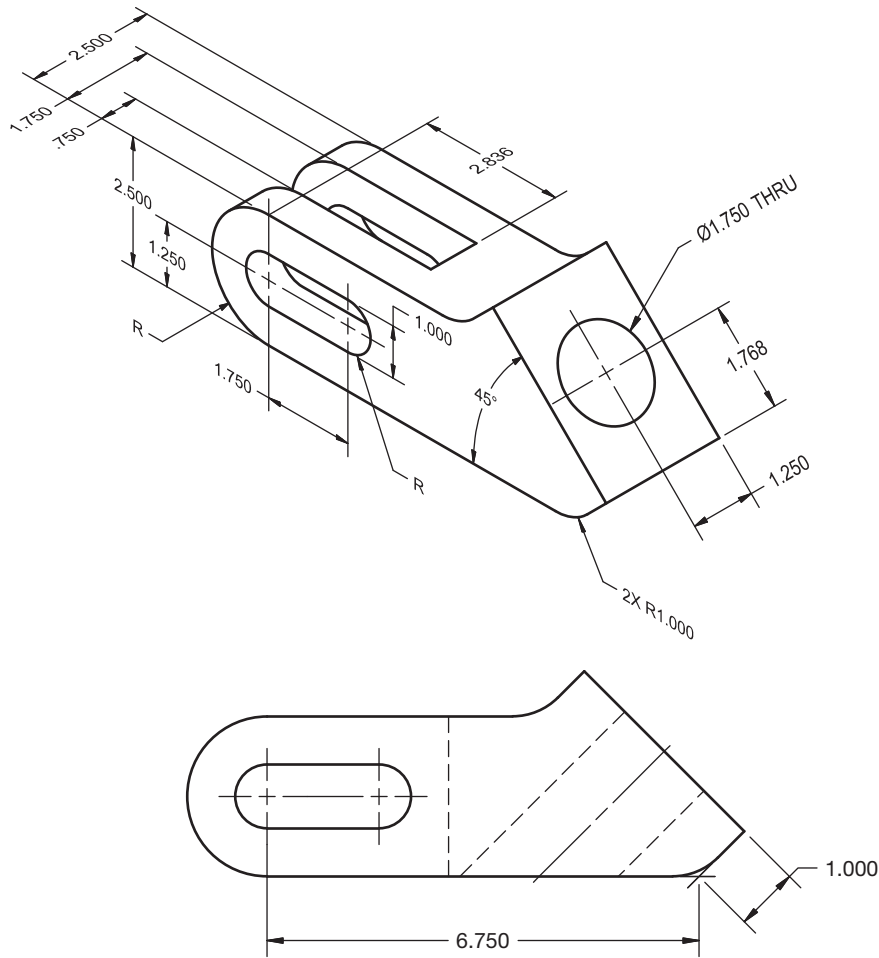


**PROBLEM 9.38 Rotated primary auxiliary view (in.)**

Title: Coupler

Material: Cast iron

Draw the required auxiliary view using the viewing-plane line rotation method.



© Cengage Learning 2012

**PROBLEM 9.39 Rotated primary auxiliary view (in.)**

Title: Coupler

Material: Cast iron

Given the same part provided in Problem 9.38, draw the required auxiliary view using the arrow and rotation arrow method.

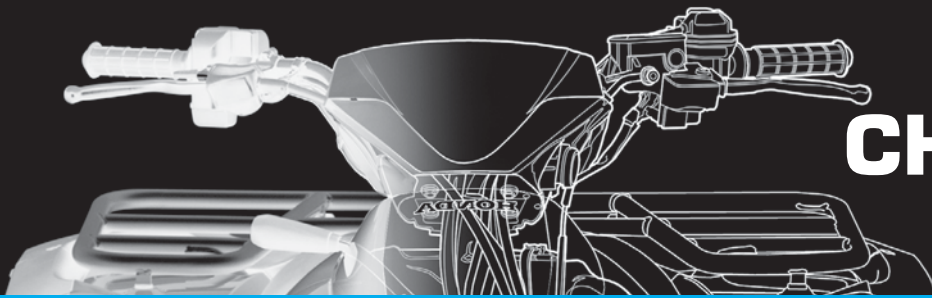
**Math Problems**

**Part 8: Problems 9.40 Through 9.49**



To access the Chapter 9 problems, go to the Student CD, select **Chapter Tests and Problems** and **Chapter 9**, and then open the

math problem of your choice or as assigned by your instructor. Solve the problems using the instructions provided on the CD, unless otherwise specified by your instructor.



# CHAPTER 10

## Dimensioning and Tolerancing

### LEARNING OBJECTIVES

After completing this chapter, you will:

- Identify and use common dimensioning systems.
- Explain and apply dimensioning standards based on ASME Y14.5-2009.
- Apply proper specific notes for manufacturing features.
- Place proper general notes and flag notes on a drawing.
- Interpret and use correct tolerancing techniques.
- Prepare completely dimensioned multiview drawings from engineering sketches and industrial drawings.
- Apply draft angles as needed to a drawing.
- Dimension CAD/CAM machine tool drawings.
- Prepare casting and forging drawings.
- Provide surface finish symbols on drawings.
- Solve tolerance problems including limits and fits.
- Use an engineering problem as the basis for your layout techniques.
- Describe the purpose of ISO 9000 Quality Systems Standard and related standards.

## THE ENGINEERING DESIGN APPLICATION

A complete detail drawing is made up of multiviews and dimensions. The layout techniques of a detail drawing must include an analysis of how the views and dimensions go together to create the finished drawing. The most effective way to form preliminary layout ideas is with rough sketches as described in Chapter 5. The following gives you a preliminary look at the steps used in the creation of a completely dimensioned multiview drawing from an engineer's sketch. Although this is only a brief introduction to what you will learn throughout this chapter, it gives you an idea of the process a drafter goes through when given this assignment.

Consider the engineering sketch in Figure 10.1 as you evaluate how to prepare a complete detail drawing. The procedure is the same with CADD or manual drafting.

**STEP 1** Select and make a rough sketch of the proper multiviews. Leave plenty of space between views to add dimensions. The engineer's sketch is not always accurate. It is your responsibility to convert the engineering ideas from the rough stage to a formal drawing. The information provided by the engineer may be correct, but the organization of information and proper layout of the drawing is up to you. Figure 10.2 shows the rough sketch of the multiviews you select for the drawing.

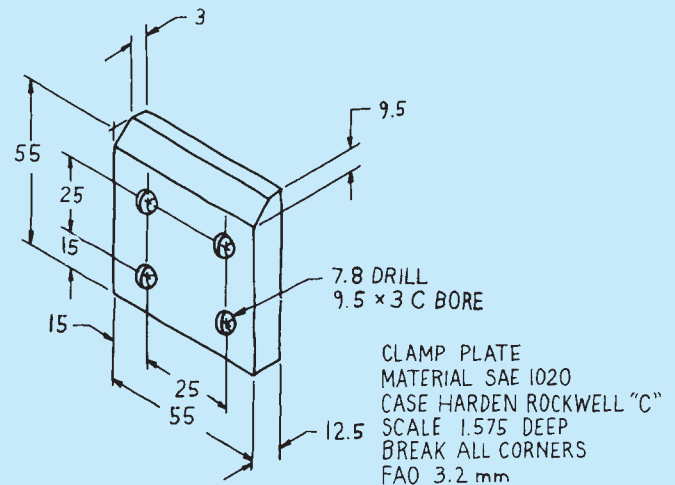


FIGURE 10.1 Engineering sketch. © Cengage Learning 2012

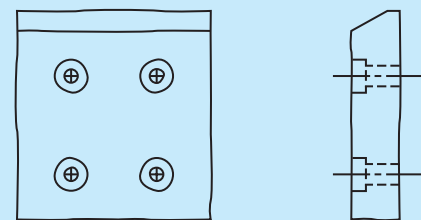
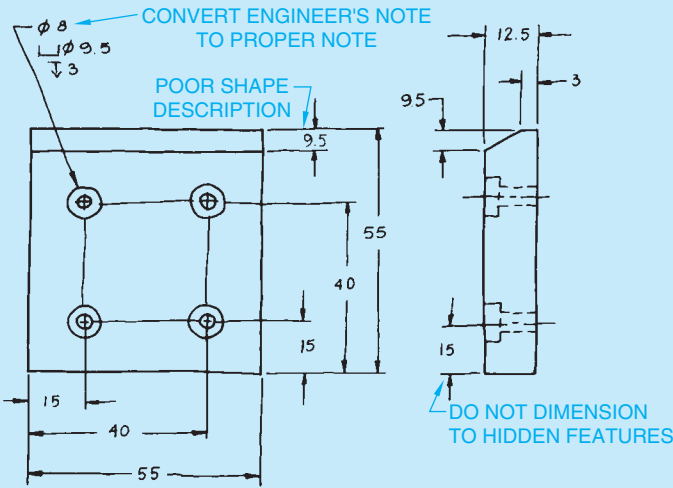


FIGURE 10.2 Rough sketch of selected multiviews.

© Cengage Learning 2012



**FIGURE 10.3** Rough sketch with dimensions and notes place. In this rough sketch, as in the real world, the dimensions and features are often out of proportion. © Cengage Learning 2012

**STEP 2** Place dimensions and notes on your multiview sketch as shown in Figure 10.3. Keep the following dimensioning rules in mind as you select and place the dimensions.

- Begin with smallest dimension closest to the object and place dimensions that progressively increase in size farther away from the object.
- Do not crowd dimensions.
- Dimension between views where possible.
- Dimension to views that show the best shape of features.
- Group dimensions when possible.
- Do not dimension size or location dimensions to hidden features.
- Stagger adjacent dimension numerals.
- Use leaders to label specific notes properly.
- Convert all information to proper drafting standards.
- Evaluate these basic rules as you decide where dimensions should be placed.

**STEP 3** Determine the scale to use based on the amount of detail to be shown and the total size of the part.

You decide that the clamp plate can easily be drawn full scale.

**STEP 4** Determine the sheet size based on the drawing scale to be used, the total drawing area, including views and dimensions, and the amount of clear area needed for general notes and future revisions. Refer to Chapter 6. Use a recommended ASME border and title block as described in Chapter 2.

Look at Figure 10.3 as you follow the calculations to determine the width and height of the drawing area needed for the clamp plate. The engineer’s sketch shows dimension values in millimeters, which is the commonly used metric value. You should do the preliminary layout work using metric values if the drawing is in metric. Use inch values if the drawing is dimensioned in inches. The spacing suggestions are presented as guidelines and can vary, depending on your specific drawing and school or company practices. The spacing calculations are also approximate and are used as a general guide for setting up your drawing. When using CADD, these values can be adjusted easily while working on your drawing and can be changed to fit any desired sheet size during the final layout process. Additional information is provided throughout this chapter.

The following provides values for laying out the width of the proposed drawing:

Width of drawing area in millimeters	
Front view width	55
Space between views:	
Space from front view to first dimension	20
Space from first to second dimension	10
Space from second to third dimension	10
Open space	20
Space from right-side view to first dimension	20
Right-side view depth	+12.5
Drawing area total width	147.5
Round off drawing area to	148

The space from the view to the first dimension and the spaces between dimensions are a drafting decision. The first space is often, but not always, larger than distances to additional dimension lines. Each dimension line, after the first, is equally spaced so dimensions are not crowded.

The following gives approximate calculations for the height of the drawing area:

Height of drawing area in millimeters	
Height of views	55
Space from front view to first dimension below view	20
Space from first to second dimension	10
Space from second to third dimension	10
Space from right-side view to first dimension above view	20
Space from first to second dimension above right-side view	+10
There should be enough space for the counterbore note.	
Drawing area total height	125

The total width and height of the drawing area is 148 × 125. Keep in mind that these calculations are approximate. There should be enough space on your drawing for some flexibility. Select an A3- or B-size sheet for this drawing. Figure 10.4 shows the 148 × 125 drawing area blocked out on an A3-size sheet using construction lines that can be erased, turned off, or frozen when finished. The drawing area can be adjusted by resizing or moving at any time. It is only a preliminary guide for laying out the drawing.

**STEP 5** Project the selected multiviews.

**STEP 6** Use the selected dimension spacing and placement from rough sketch. Draw hidden lines and centerlines on a designated layer with proper line thickness and style. Use a dimensioning

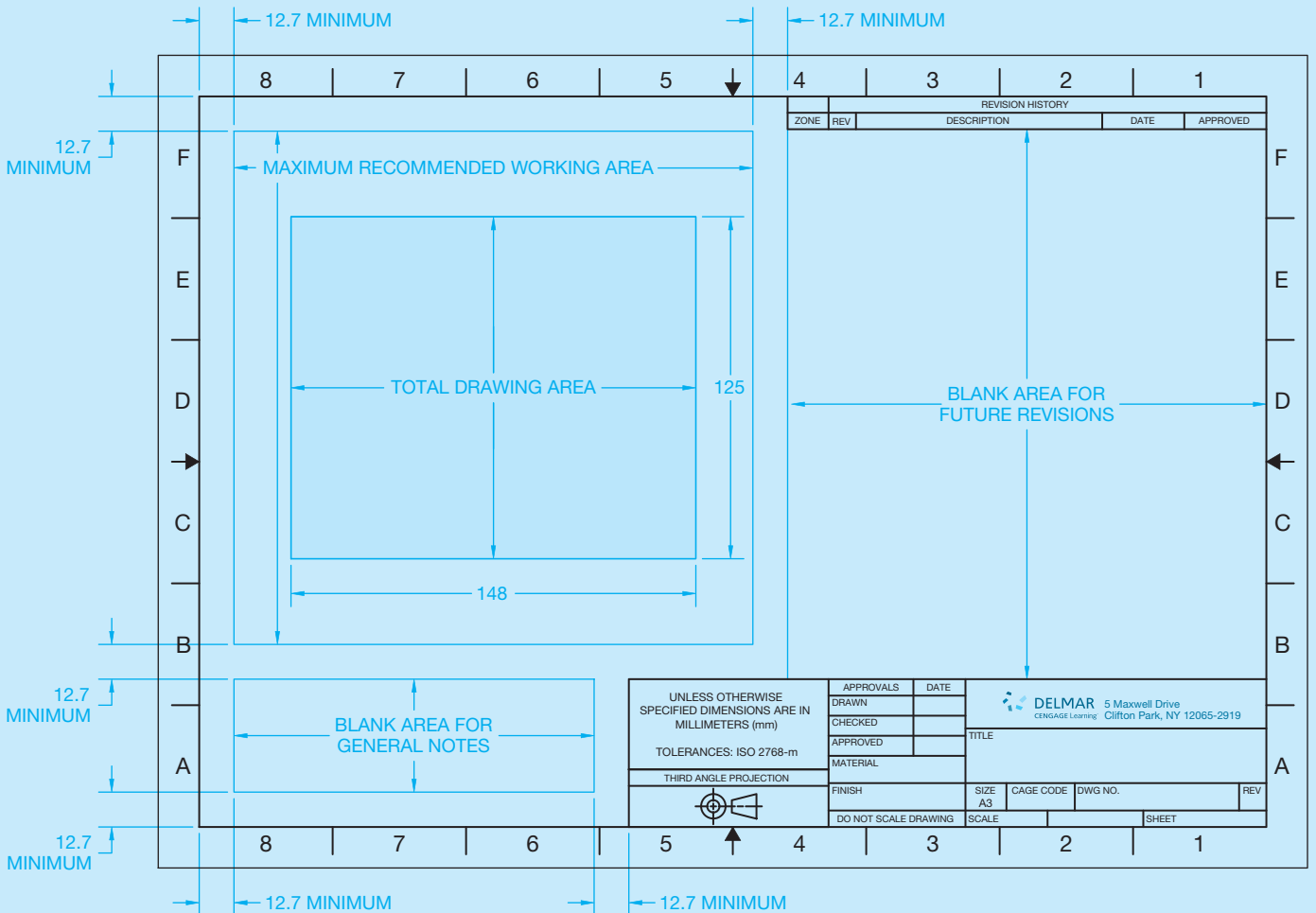
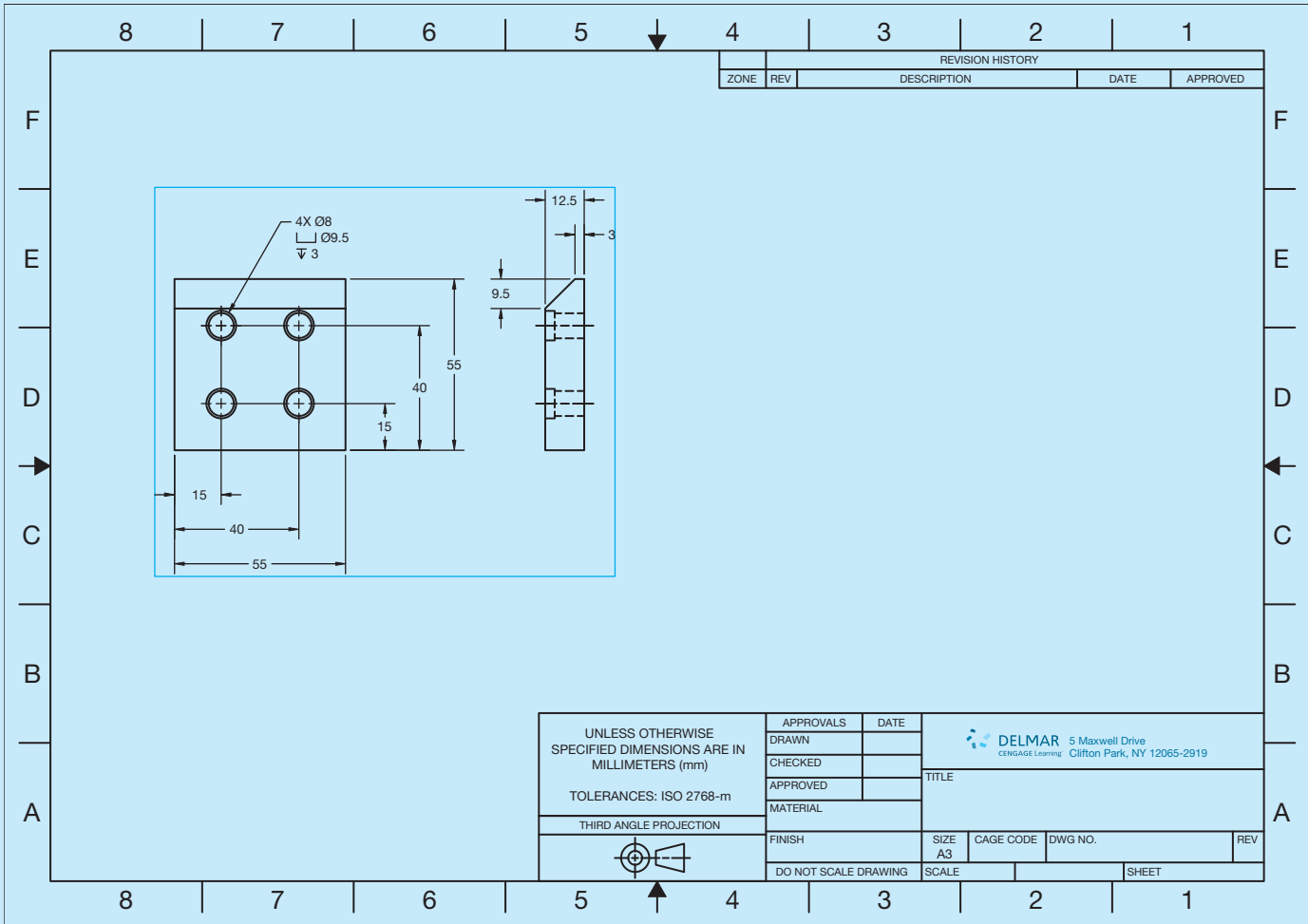


FIGURE 10.4 Establish the approximate drawing area. © Cengage Learning 2012

layer. Use a linear dimensioning command or tool to place vertical and horizontal dimensions. Uniformly space the dimensions on the views. Use a leader command or tool to place the leader line and counterbore note. This drafter chose to change the hole location dimensions to the baseline method. This system is defined

and advantages given later in this chapter (see Figure 10.5).

**STEP 7** Complete the detail drawing by adding the general notes and filling in the title block information (see Figure 10.6). Erase, turn off, or freeze any remaining construction lines.



**FIGURE 10.5** Lay out the multiviews with object lines, hidden lines, and centerlines. Layout the dimensions with extension and dimension lines, dimension numerals, leader lines, and arrowheads and place the specific notes. © Cengage Learning 2012

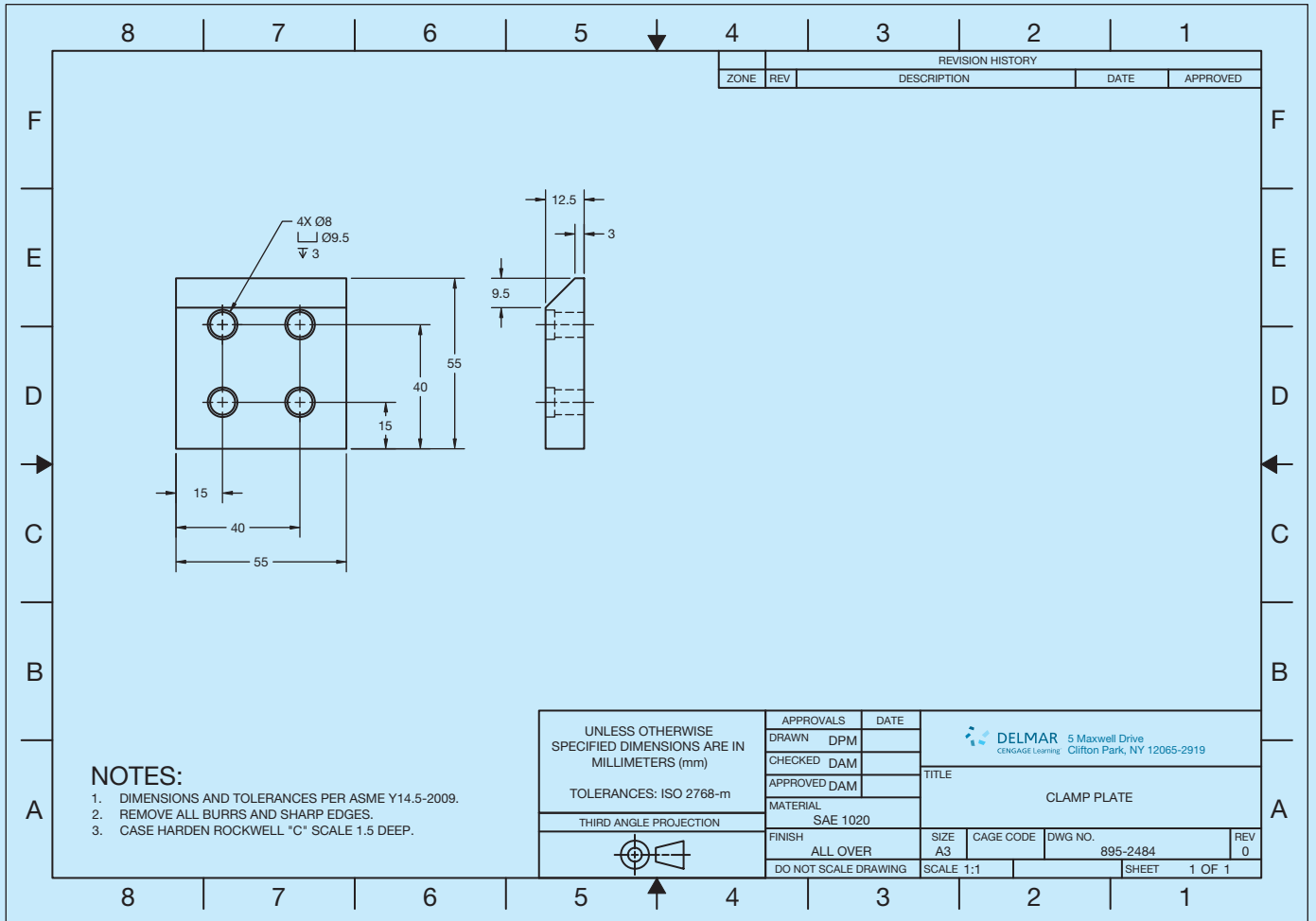


FIGURE 10.6 Complete the drawing with the general notes place in the lower-left corner and fill in the title block information. © Cengage Learning 2012

## INTRODUCTION TO DIMENSIONING

A **dimension** is a numerical value or values or mathematical expression provided in appropriate units of measure and used to define form, size, orientation, or location of a feature or part. Dimensions can also contain standard symbols that are unique to the specific dimensioned feature or dimensioning application. This chapter provides information about and practices used for placing dimensions on mechanical drawings for manufacturing, referred to as *engineering drawings*. The terms and applications provide the foundation for dimensioning practices used in all disciplines. Other drafting fields such as architectural, structural, and civil drafting use different techniques and applications that are described in the chapter where the related content is described.

## STANDARDS

**ASME** The primary standard published by the American Society of Mechanical Engineers (ASME) is ASME Y14.5-2009 titled *Dimensioning and Tolerancing*. This standard establishes uniform practices for stating and interpreting dimensioning, tolerancing, and related requirements for use on engineering drawings and related documents. The standard ASME Y14.5.1, *Mathematical Definition of Dimensioning and Tolerancing Principles*, provides a mathematical definition of geometric dimensioning and tolerancing (GD&T) for the application of ASME Y14.5. ASME Y14.5.2, *Certification of Geometric Dimensioning and Tolerancing Professionals*, establishes certification requirements for a Geometric Dimensioning and Tolerancing

Professional (GDTP). The standard ASME Y14.31, *Undimensioned Drawings*, provides the requirements for undimensioned drawings that graphically define features with true geometry views without the use of dimensions. ASME Y14.43, *Dimensioning and Tolerancing Principles for Gages and Fixtures*, provides practices for dimensioning and tolerancing of gages and fixtures used for the verification of maximum material condition. The standard that controls general dimensional tolerances found in the dimensioning and tolerancing block or in general notes is ASME Y14.1, *Decimal Inch Drawing Sheet Size and Format*, and ASME Y14.1M, *Metric Drawing Sheet Size and Format*.

The ASME Y14.41 publication, *Digital Product Definition Data Practices*, establishes requirements for the creation and revision of *digital product definition data sets*. Digital product definition data sets are computer files that completely define a product. The physical and functional requirements of the product are defined, in the computer files, by graphical or textual presentations or a combination of both. The data set includes all information required to fully define the product. Information included in the data set can be a 3-D CADD model, its annotations, and any other supporting documentation believed necessary. The standard supports two methods of defining the product: model only, and model and drawing. Existing ASME standards should be used for drawing creation. However, ASME Y14.41 defines exceptions to existing standards and additional requirements for use on data sets and digital drawings.

If a company decides to completely define the product using only a CADD model, the standard provides guidance for the application of GD&T, size dimensions, and tolerances directly to the model. A company might also decide to use a combination of a CADD model and a 2-D drawing to define the product completely. In this case, the standard provides requirements for the relationship between the model and the drawing. For example, the information on the drawing and in the model shall match. The drawing shall reference all models defined by the drawing. The drawing border and sheet block information is created per ASME Y14.1 or ASME Y14.1M. If the drawing does not contain complete product definition and the model must be queried for complete definition, it shall be noted on the drawing.

## DIMENSIONING BASICS

Dimension numerals are displayed using millimeters (mm) in dimensions on example drawings throughout this chapter, unless otherwise specified. Where values are given within the text content, inches are followed by millimeters in parentheses—for example, .24 in. (6 mm). If the given measurement is a specification for a standard feature such as text height, the inch standard is followed by the metric standard, even if the exact metric conversion is not accurate. For example, the standard text height is .12 in. (3 mm). In some applications, an inch value is given followed by a rounded metric conversion in parentheses. The exact metric conversion is not given in most cases in an effort to keep the information in whole millimeters.

A complete detail drawing includes multiviews and dimensions, which provide shape and size description. There are two classifications of dimensions: size and location. **Size dimensions** are placed directly on a feature to identify a specific size, or they may be connected to a feature in the form of a note. **Location dimensions** provide the relationship of features of an object. **Notes** are a type of dimension that generally identify the size of a feature or features with written specifications that are more detailed than a numerical value. For example, a note for a counterbore gives size and identification of the machine process used in manufacturing. There are two types of notes: **local notes** and **general notes**. Local notes are connected to specific features on the views of the drawing. Local notes are also commonly called *specific notes* because they are specific to a feature. General notes are placed separate from the views and relate to the entire drawing.

It is important for you to effectively combine shape and size descriptions so the drawing is easy to read and understand. Many techniques help apply this goal. You should carefully evaluate the dimensioning rules while preparing detail drawings, and you should never crowd information on a drawing. It is better to use larger paper than to crowd the drawing, unless otherwise indicated by your company or instructor.

## DIMENSIONING CHARACTERISTICS AND DEFINITIONS

An introduction to the following definitions is provided to help you gain a good understanding of the terminology associated with dimensioning practices. Many of the terms and definitions given in the following are described in further detail throughout this chapter. Additional terminology is provided as you continue through this chapter. Terminology related to geometric dimensioning and tolerancing (GD&T) is provided in Chapter 13.

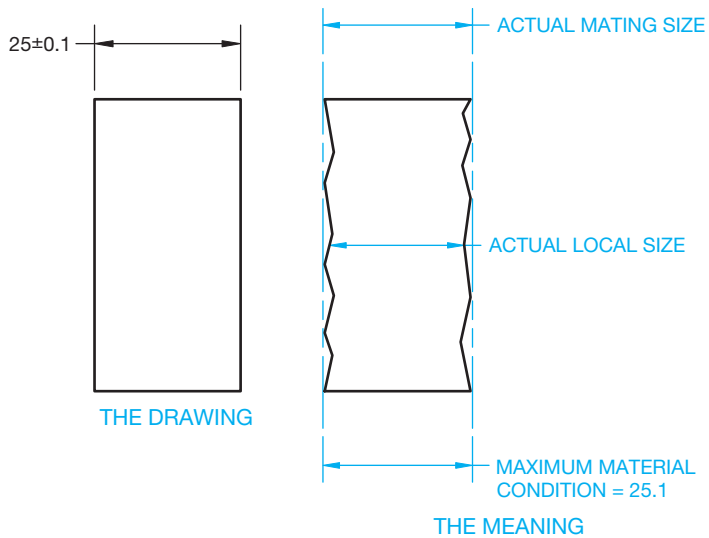
### Actual Size

The actual size is the measured size of a feature or part after manufacturing. The **actual size** includes the **actual local size** and the **actual mating size** (see Figure 10.7). The actual local size is any cross sectional measurement at any two adjacent points. There can be an infinite number of actual local size values. The actual mating size is the smallest distance between two parallel planes within



### ASME Dimensioning Symbols

For ASME dimensioning symbols, go to the Student CD, select **CD Appendices** and then **Appendix C**.



**FIGURE 10.7** The actual size includes the actual local size and the actual mating size. © Cengage Learning 2012

which the actual surface features are contained. The actual mating size could be less than Maximum material condition (MMC) if the part is manufactured to the low limit so the two parallel planes are not necessarily at MMC. The size of the feature (local and mating) must not violate the size tolerance. The two parallel planes are at maximum material condition, which is described later in this chapter.

### Allowance

**Allowance** is tightest possible fit between two mating parts. The allowance is calculated using this formula: MMC external feature – MMC internal feature = allowance.

### Basic Dimension

A **basic dimension** is considered a theoretically exact size, location, profile, or orientation of a feature or point. The basic dimension provides a basis for the application of tolerance located in feature control frames or notes. Basic dimensions are drawn with a rectangle around the numerical value. For example  $\boxed{.625}$  or  $\boxed{30^\circ}$ . This is discussed more in Chapter 13, *Geometric Dimensioning and Tolerancing*.

### Bilateral Tolerance

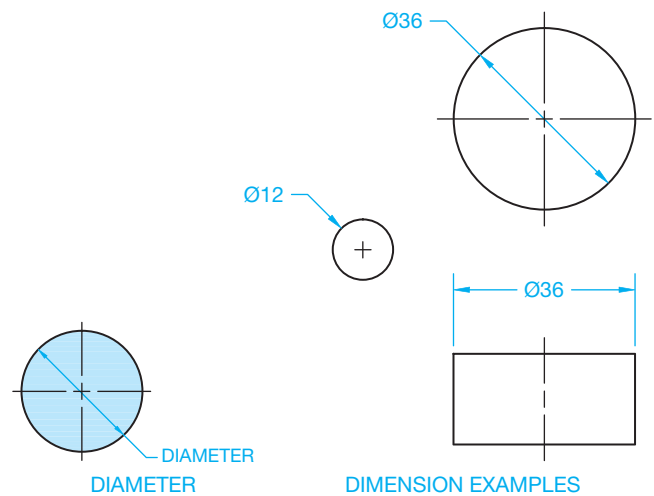
A **bilateral tolerance** is allowed to vary in two directions from the specified dimension.

Inch examples are  $.250 \begin{smallmatrix} +.002 \\ -.005 \end{smallmatrix}$  and  $.500 \pm .005$ .

Metric examples are  $12 \begin{smallmatrix} +0.1 \\ -0.2 \end{smallmatrix}$  and  $12 \pm 0.2$ .

### Datum

A **datum** is considered a theoretically exact surface, plane, axis, center plane, or point from which dimensions for related features are established.



**FIGURE 10.8** Dimensioning circles with a diameter. © Cengage Learning 2012

### Diameter

**Diameter** is the distance across a circle measured through the center. A diameter dimension is represented on a drawing with the Ø symbol preceding the value as shown in Figure 10.8. Circles on a drawing are dimensioned with a diameter.

### Dimension

A dimension is a numerical value used on a drawing to describe size, shape, location, form, or orientation of a feature.

### Feature

A **feature** is the general term applied to describe a physical portion of a part or object, such as a surface, slot, tab, pin, keyseat, or hole.

### Feature of Size

The term **feature of size** refers to one cylindrical or spherical surface, a circular element, or a set of two opposed elements or opposed parallel plane surfaces, each of which is associated with a directly tolerated dimension.

### Geometric Tolerance

**Geometric tolerance** is the general term applied to the category of tolerances used to control size, form, profile, orientation, location, and runout. Geometric tolerancing is described in detail in Chapter 13, *Geometric Dimensioning and Tolerancing*.

### Least Material Condition (LMC)

**Least material condition (LMC)** is the condition in which a feature contains the least amount of material allowed by the size limits. For example, the lower limit for an external feature and the upper limit for an internal feature.



## Limits of Dimension

The **limits** of a dimension are the largest and smallest possible boundaries to which a feature can be made as related to the tolerance of the dimension. Consider the following inch dimension and tolerance:  $.750 \pm .005$ . The limits of this dimension are calculated as follows:  $.750 + .005 = .755$  upper limit, and  $.750 - .005 = .745$  lower limit. For the metric dimension  $19.00 \pm 0.15$ ,  $19.00 + 0.15 = 19.15$  is the upper limit, and  $19.00 - 0.15 = 18.85$  is the lower limit.

## Maximum Material Condition (MMC)

The **maximum material condition (MMC)**, given the limits of the dimension, is the situation in which a feature contains the most material possible. MMC is the largest limit for an external feature and the smallest limit for an internal feature.

## Nominal Size

**Nominal size** is a dimension used for general identification such as stock size and thread diameter.

## Radius

A **radius** is the distance from the center of a circle to the outside. Arcs are dimensioned on a drawing with a radius. A radius dimension is preceded by an R. The symbol CR refers to

a **controlled radius**, a term applied when the limits of the radius tolerance zone must be tangent to the adjacent surfaces. The radius must be a **fair curve**, and radii taken at all points on the part contour shall be neither smaller than the specified minimum limit nor larger than the specified maximum limit. A fair curve is a smooth curve without sharp changes in direction over any portion of its length. The symbol SR refers to a spherical radius, which is the radius of a sphere (see Figure 10.9).

## Reference Dimension

A reference dimension is used for information purposes only and is usually without a tolerance. A reference dimension does not govern production or inspection. Reference dimensions are enclosed in parentheses on the drawing, such as (25) (see Figures 10.12 and 10.13).

## Stock Size

**Stock size** is a commercial or premanufactured size, such as a particular size of square, round, or hex steel bar.

## Specified Dimension

The **specified dimension** is the part of the dimension from which the limits are calculated. For example, the specified dimension of  $.625 \pm .001$  in. is .625. In the following metric example,  $15 \pm 0.1$  mm, 15 is the specified dimension.

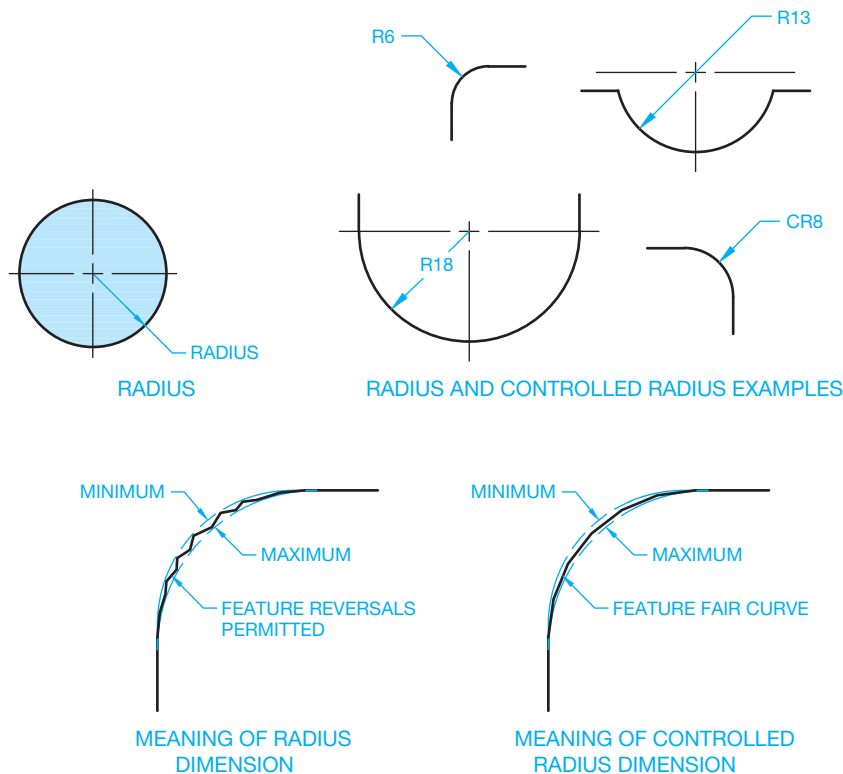


FIGURE 10.9 Dimensioning a radius and a controlled radius.

## Tolerance

The **tolerance** of a dimension is the total permissible variation in size or location. Tolerance is the difference of the lower limit from the upper limit. For example, the limits of  $.500 \pm .005$  in. are .505 and .495, making the tolerance equal to .010 in. These are the tolerance calculations:  $.500 + .005 = .505$  upper limit,  $.500 - .005 = .495$  lower limit, and  $.505 - .495 = .010$  tolerance. The tolerance for this metric example,  $12 \pm 0.1$  mm, is 0.2 mm. This is the tolerance calculation:  $12 + 0.1 = 12.1$  upper limit,  $12 - 0.1 = 11.9$  lower limit, and  $12.1 - 11.9 = 0.2$  tolerance.

A tolerance is not given to values that are identified as reference, maximum, minimum, or stock sizes. The tolerance can be applied directly to the dimension, indicated by a general note, or identified in the drawing title block.

## Unilateral Tolerance

A **unilateral tolerance** is a tolerance that has a variation in only one direction from the specified dimension, as in  $.875 \begin{smallmatrix} +.000 \\ -.002 \end{smallmatrix}$  in. or  $22 \begin{smallmatrix} 0 \\ -0.2 \end{smallmatrix}, 22 \begin{smallmatrix} +0.2 \\ 0 \end{smallmatrix}$  mm.

## FUNDAMENTAL DIMENSIONING RULES

The following rules are summarized from ASME Y14.5-2009. These rules are intended to give you an understanding of the purpose for standardized dimensioning practices. Short definitions are given in some cases for terminology that is explained in detail in this textbook.

- Each dimension has a tolerance except for dimensions specifically identified as reference, maximum, minimum, or stock. The tolerance can be applied directly to the dimension, applied indirectly in the case of basic dimensions, indicated by a general note, or located in the title block of the drawing.
- Dimensioning and tolerancing must be complete to the extent that there is full understanding of the characteristics of each feature. Neither measuring the drawing nor assumption of a dimension is permitted. Exceptions include drawings such as loft, printed wiring, templates, and master layouts prepared on stable material. However, in these cases the necessary control dimensions must be given.
- Each necessary dimension of an end product must be shown. Only dimensions needed for complete definition should be given. Reference dimensions should be kept to a minimum.
- Dimensions must be selected and arranged to suit the function and mating relationship of a part.
- Dimensions must not be subject to more than one interpretation.
- The drawing should define the part without specifying the manufacturing processes. For example, give only the diameter of a hole without a manufacturing process such as DRILL or REAM. However, there should be specifications given on the drawing, or related documents, in cases where manufacturing, processing, quality assurance, or environmental information is essential to the definition of engineering requirements.
- It is allowed to identify (as nonmandatory) certain processing dimensions that provide for finish allowance, shrink allowance, and other requirements, provided the final dimensions are given on the drawing. Nonmandatory processing dimensions should be identified by an appropriate note, such as NONMANDATORY (MFG DATA).
- Dimensions should be arranged to provide required information arranged for optimum readability. Dimensions should be shown in true profile views and should refer to visible outlines.
- Wires, cables, sheets, rods, and other materials manufactured to gage or code numbers should be specified by dimensions indicating the diameter or thickness. Gage or code numbers can be shown in parentheses following the dimension.
- A 90° angle is implied where centerlines and lines displaying features are shown on a 2-D drawing at right angles and no angle is specified. The tolerance for these 90° angles is the same as the general angular tolerance specified in the title block or in a general note.
- A 90° basic angle applies where centerlines of features are located by basic dimensions and no angle is specified. Basic dimensions are considered theoretically perfect in size, profile, orientation, or location. Basic dimensions are the basis for variations that are established by other tolerances.
- A zero basic dimension applies where axes, center planes, or surfaces are shown one over the other on a drawing and geometric controls establish the relationship between the features.
- Unless otherwise specified, all dimensions and tolerances are measured at 20°C (68°F). Compensation can be made for measurements taken at other temperatures.
- Unless otherwise specified, all dimensions and tolerances apply in a *free state condition* except for nonrigid parts. Free state condition describes distortion of the part after removal of forces applied during manufacturing. Nonrigid parts are those that can have dimensional change due to thin wall characteristics.
- Unless otherwise specified, all tolerances apply for the full depth, length, and width of the feature.
- Dimensions and tolerances apply on the drawing where specified.
- A coordinate system shown on a drawing is considered right-handed unless otherwise specified. Right-handed means that the coordinate system is arranged clockwise. Each axis shall be labeled and the positive direction shown.
- A 3-D model coordinate system shall comply with ASME Y14.41, *Digital Product Definition Data Practices*, when shown on a drawing.

## DIMENSIONING COMPONENTS

The types of lines and the text used in dimensioning were introduced in Chapter 6. The following provides a brief review of these and gives additional information related to dimensioning components. Look at Figure 10.10 as you review the following. The terminology used in Figure 10.10 also correlates with dimensioning terminology commonly used in CADD.

- **Dimension lines** indicate the length of the dimension. They are thin lines capped on the ends with arrowheads and broken along the length, providing a space for the dimension numeral. The **gap** between the dimension line and the dimension numeral varies but is commonly .06 in. (1.5 mm). Dimension lines for architectural and structural drafting have different characteristics as discussed in Chapter 22, *Structural Drafting*.
- An **angular dimension line** is an arc with the center of the arc from the vertex of the angle.
- **Dimension text** is normally .12 in. (3 mm) high, centered in the space provided in the dimension line.
- A **leader line** is a thin line used to connect a specific note to a feature on the drawing. The leader line can be at any angle between 15°–75°, with 45° preferred. There is a short

horizontal **shoulder** between .12 and .24 in. (3–6 mm), centered where it meets the text.

- **Arrowheads** are used to cap the dimension line and leader line ends. These are discussed in detail later.
- **Extension lines** are thin lines used to establish the extent of a dimension. They start with a small offset of .06 in. (1.5 mm) from the object and extend .12 in. (3 mm) past the last dimension line. Extension lines do not extend between views.
- The **center dash** is part of the centerline and is drawn as thin lines. Center dashes are generally drawn .12 in. (3 mm). Additional center dash information is provided later in this chapter. The center dashes in Figure 10.7 cross at the center of the circle and are used to dimension the center location. Centerlines become extension lines as they extend out to the dimension. Centerlines do not extend between views, unless as applied to an auxiliary view discussed in Chapter 9.
- The **centerline space** is commonly .06 in. (1.5 mm). This is the space between the short and long dashes of the centerline. The **centerline offset** is the part of the centerline extending beyond the circle or other related feature. The centerline extension is generally .12–.24 in. (3–6 mm).

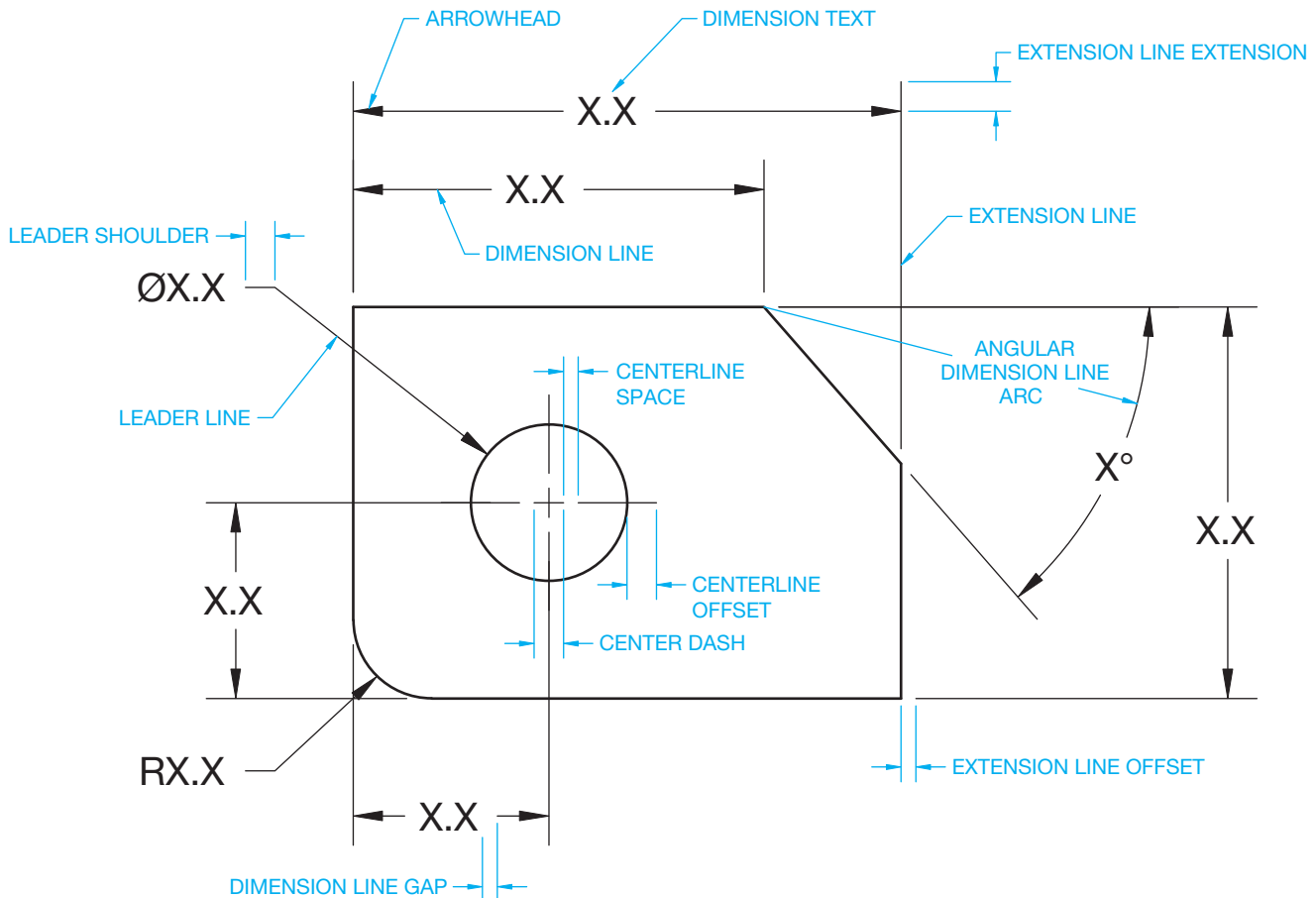


FIGURE 10.10 Standard dimensioning characteristics. © Cengage Learning 2012

### DIMENSIONING SYMBOLS

Symbols are commonly used in drafting to replace words, to simplify the drawing, to aid in clarity, and to ease drawing presentation. The symbols used throughout this chapter represent a universal language that has been adopted by the ASME. Many

of these symbols are also adopted by the international community governed by the International Organization for Standardization (ISO), although, some ISO symbols are different. Individual symbols are represented and detailed throughout this chapter each time they are introduced. Figure 10.11 shows the ASME standard dimension symbols.

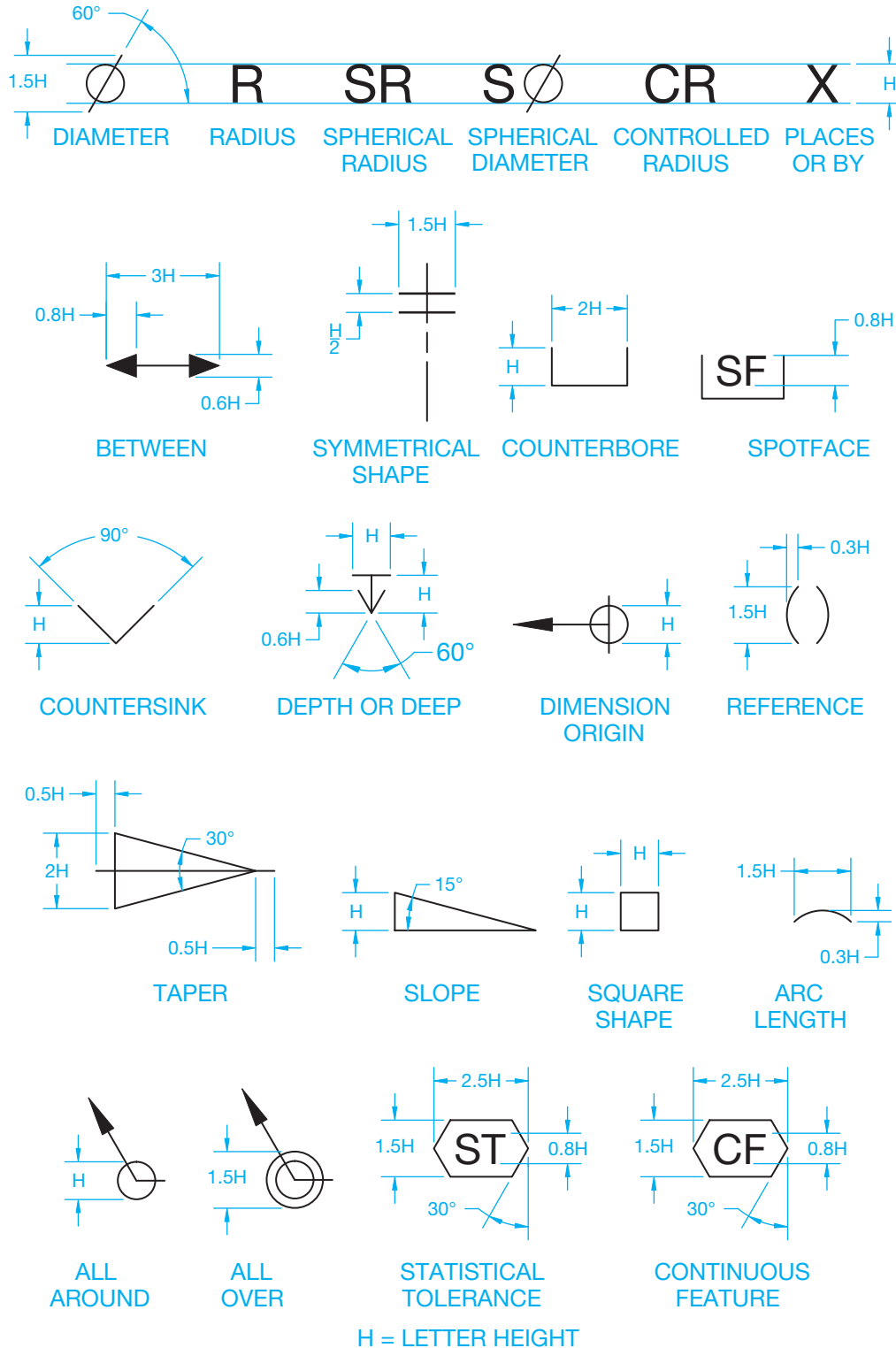


FIGURE 10.11 Standard ASME-recommended dimensioning symbols. © Cengage Learning 2012

## DIMENSIONING SYSTEMS

Dimensioning systems refers to the manner in which dimensions are applied to drawings for different applications.

### Unidirectional Dimensioning

**Unidirectional dimensioning** is commonly used in mechanical drafting for manufacturing. Unidirectional dimensioning requires that all numerals, figures, and notes be lettered horizontally and be read from the bottom of the drawing sheet. Figure 10.12 shows unidirectional dimensioning in use. The dimension in parentheses (80) is a reference dimension defined earlier.

### Aligned Dimensioning

**Aligned dimensioning** requires that all numerals, figures, and notes be aligned with the dimension lines so they can be read from the bottom for horizontal dimensions and from the right side for vertical dimensions (see Figure 10.13). Aligned dimensioning is commonly used in architectural and structural drafting.

### Rectangular Coordinate Dimensioning without Dimension Lines

Omitting dimension lines is common for drawings in industries that use computer-controlled machining processes and when unconventional dimensioning practices are required because of product features. **Rectangular coordinate dimensioning without dimension lines** is a type of dimensioning that includes only extension lines and text aligned with the extension

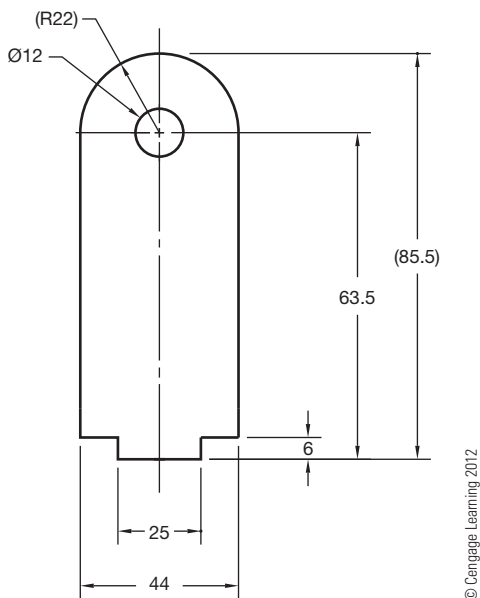


FIGURE 10.12 Unidirectional dimensioning.

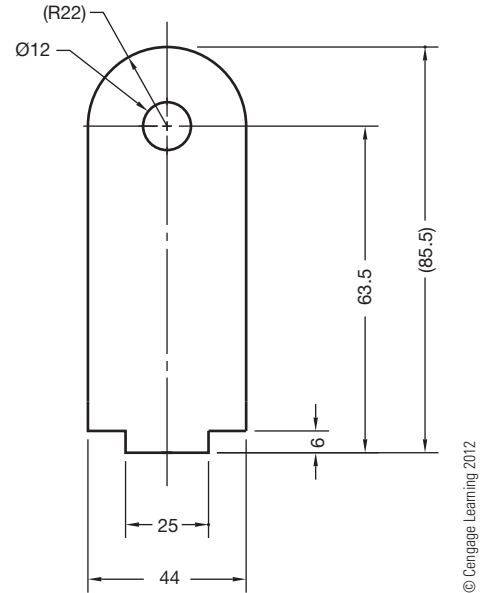
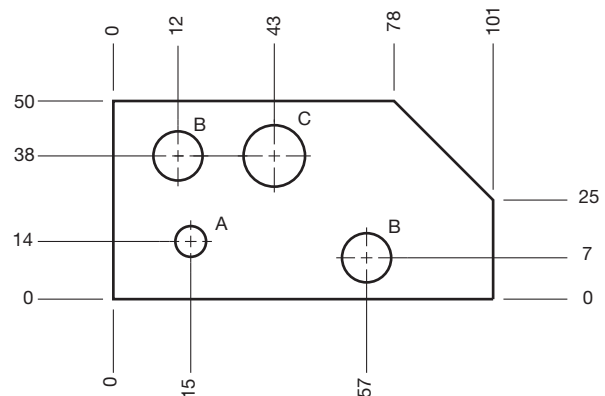


FIGURE 10.13 Aligned dimensioning.



HOLE SYMBOL	HOLE DIA	QTY
A	6	1
B	9	2
C	12	1

FIGURE 10.14 Rectangular coordinate dimensioning without dimension lines.

lines. Each dimension represents a measurement originating from datums or coordinates (see Figure 10.14). Often identification letters label holes or similar features. A table, keyed to the identification letters, indicates feature size or specifications. Alternately, features sizes, such as holes, can be dimensioned using traditional leaders and notes rather than using a table. Use of the table is common, so you should confirm the desired practice with your employer or instructor. Rectangular coordinate dimensioning without dimension lines is popular for specific applications, such as precision sheet metal part

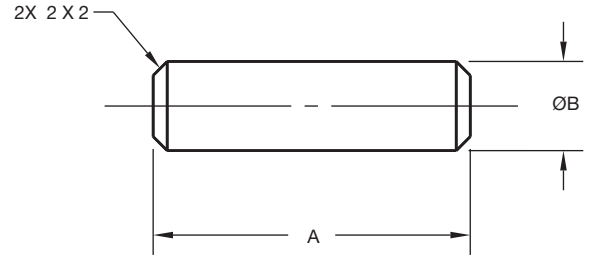
drawings and electronics drafting, especially for chassis layout. Rectangular coordinate dimensioning without dimension lines is also called **ordinate dimensioning**.

### Tabular Dimensioning

**Tabular dimensioning** is a form of rectangular coordinate dimensioning without dimension lines in which size and location dimensions from datums or coordinates (*X*, *Y*, *Z* axes) are given in a table identifying features on the drawing. In tabular dimensioning, each feature receives a label with a letter or number that correlates to a table. Some companies take this practice one step further and display the location and size of features in the table from an *X* and a *Y* axis. The depth of features is also provided from the *Z* axis where appropriate. Each feature is labeled with a letter or number that correlates to the table, as shown in Figure 10.15.

### Chart Drawing

**Chart drawings** are used when a particular part or assembly has one or more dimensions that change depending on the specific application. For example, the diameter of a part and the lengths have alternate dimensions required for different purposes. The variable dimension is usually labeled on the drawing with a letter in the place of the dimension. The letter is placed in a chart in which the changing values are identified. Figure 10.16 is a chart drawing showing dimensions having alternate sizes. The view drawn represents a typical part, and the dimensions are labeled *A* and *B*. The correlated chart identifies the various (*A*) lengths available at given (*B*) diameters. The chart in this example also shows purchase part numbers



LENGTH A	B=20.3	B=38.1	B=50.8	B=57.2
	PART NO.	PART NO.	PART NO.	PART NO.
76	DP20.3-76.2	DP38.1-76.2	DP50.8-76.2	DP57.2-76.2
101	DP20.3-101.6	DP38.1-101.6	DP50.8-101.6	DP57.2-101.6
127	DP20.3-127	DP38.1-127	DP50.8-127	DP57.2-127
152	DP20.3-152.4	DP38.1-152.4	DP50.8-152.4	DP57.2-152.4

FIGURE 10.16 Chart drawing. © Cengage Learning 2012

for each specific item. This method of dimensioning is commonly used in vendor or specification catalogues for alternate part identification.

### DIMENSIONING FUNDAMENTALS

Dimension layout standards are established to help make sure dimensions are represented the same on all drawings. There are varieties of variables that make up the dimensioning layout as shown in Figure 10.17. The variables displayed in this figure represent the recommended standard.

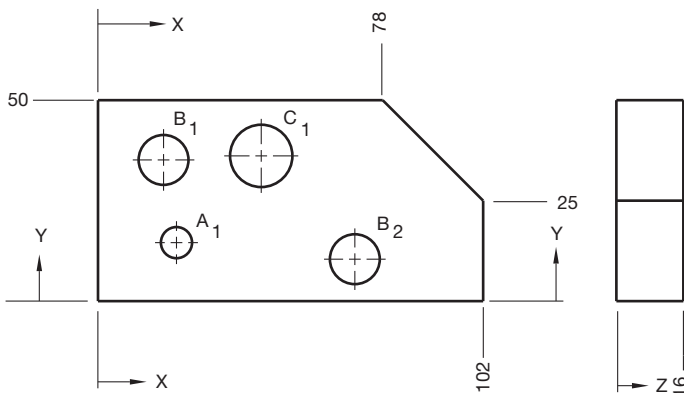
### Dimensioning Units

The metric **International System of Units (SI)** is commonly used in this chapter because SI units are provided in ASME Y14.5-2009 rather than **United States (U.S.) customary units** for use on engineering drawings. Metric units expressed in **millimeters** or U.S. customary units expressed in **decimal inches** are considered the standard units of linear measurement on engineering documents and drawings.

The selection of millimeters or inches depends on the specific application and the needs of the individual company. When all dimensions are either in millimeters or inches, the general note, **UNLESS OTHERWISE SPECIFIED, ALL DIMENSIONS ARE IN MILLIMETERS (or INCHES)**, is placed on the drawing. Inch dimensions should be followed by *IN* on mostly millimeter-dimensioned drawings, and *mm* should follow millimeter dimensions on mostly inch-dimensioned drawings.

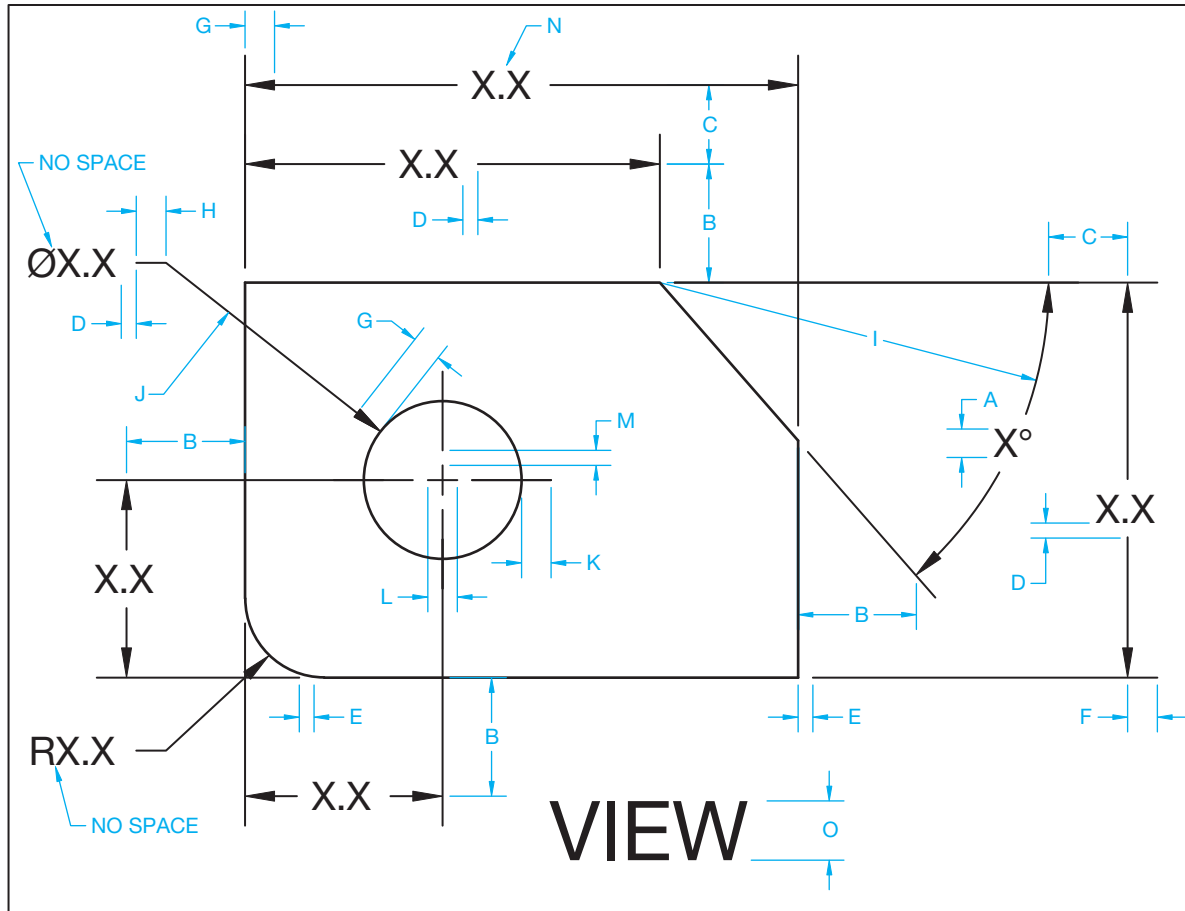
### Decimal Points

When dimensions have numerals containing decimal points, the decimal points should be uniform throughout the drawing.



HOLE SYMBOL	HOLE DIA	LOCATION		DEPTH Z
		X	Y	
A <sub>1</sub>	6	15	14	THRU
B <sub>1</sub>	9	12	38	9
B <sub>2</sub>	9	57	7	12
C <sub>1</sub>	12	43	38	THRU

FIGURE 10.15 Tabular dimensioning. © Cengage Learning 2012



KEY	DESCRIPTION	INCH VALUE (IN)	METRIC VALUE (mm)
A	DIMENSION TEXT HEIGHT	.12	3
B	FIRST DIMENSION LINE SPACING	.375 (MINIMUM)	10 (MINIMUM)
C	FOLLOWING DIMENSION LINE SPACING	.25 (MINIMUM)	6 (MINIMUM)
D	DIMENSION LINE GAP	.063	1.5
E	EXTENSION LINE OFFSET	.063	1.5
F	EXTENSION LINE EXTENSION	.125	3
G	ARROWHEAD LENGTH	.125	3
H	SHOULDER LENGTH	.125 - .25	3 - 6
I	DIMENSION LINE ARC	RADIUS FROM ANGLE VERTEX	RADIUS FROM ANGLE VERTEX
J	LEADER ANGLE	15° - 75° (45° PREFERRED)	15° - 75° (45° PREFERRED)
K	CENTERLINE OFFSET	.125	3
L	CENTER DASH	.125	3
M	CENTERLINE SPACE	.063	1.5
N	LETTERING/FONT	SINGLE STROKE/ROMANS	SINGLE STROKE/ROMANS
O	TITLE HEIGHT	.24	6

© Cengage Learning 2012

FIGURE 10.17 Standard dimensioning layout standards and specifications.

The decimal should be clear and bold and in line with the bottom of the numerals, for example, 1.750. A specified dimension in inches is expressed to the same number of decimal places as its tolerance, and zeros are added to the right of the decimal point if needed; for example, .500 ±.002.

### Using Metric and Inch Units

Specific rules apply to the use of metric and inch units. The following describes the use of metric, inch, and angular units as shown in Figure 10.18.

		35°
	2.00	24.5°
	2.375	30°15'35"
28	.625	0°45'30"
24.5	.750 <sup>+0.002</sup> <sub>-0.003</sub>	30°0'±0°5'
0.5	.750±.005	0°0'30"±0°0'15"
24 <sup>+0.08</sup> <sub>-0.20</sub>	.625 <sup>+0.000</sup> <sub>-0.004</sub>	25.0°±0.5°
24±0.1	.625 <sup>+0.004</sup> <sub>-0.000</sub>	30° <sup>0</sup> <sub>-2°</sub>
24 <sup>0</sup> <sub>-0.2</sub> 24 <sup>+0.2</sup> <sub>0</sub>		25.5° <sup>0</sup> <sub>-0.2°</sub>
7.0-7.5	1.000-1.062	30°0'0"-30°30'30"
24.25	1.000	15°30'45"
24.30	1.062	15°30'0"
<b>METRIC</b>	<b>INCH</b>	<b>ANGULAR</b>

© Cengage Learning 2012

FIGURE 10.18 Displaying metric, inch, and angular dimension values.

### Placing Millimeter Dimensions

The following outlines the proper use of metric units on engineering drawings:

- The decimal point and zero are omitted when the metric dimension is a whole number. For example, the metric dimension 12 has no decimal point.
- A zero precedes a decimal millimeter that is less than 1. For example, the metric dimension 0.5 has a zero before the decimal point.
- When the metric dimension is greater than a whole number by a fraction of a millimeter, the last digit to the right of the decimal point is not followed by a zero. For example, the metric dimension 12.5 has no zero to the right of the 5. This rule is true unless tolerance values are displayed.
- Plus and minus values of a metric tolerance have the same number of decimal places. Zeros are added to fill in where needed. For example, 24<sup>+0.25</sup><sub>-0.10</sub> and 24.25<sub>24.00</sub>.
- Metric limit tolerance values have the same number of decimal points. When limit tolerance values are displayed on one line, such as 7.5–7.6, the lower value precedes the higher value, and the values are separated with a dash. When limit tolerance values are displayed stacked, such as  $\begin{matrix} 7.6 \\ 7.5 \end{matrix}$ , the higher value is placed above the lower value.
- Examples in ASME Y14.5 show no zeros after the specified dimension to match the tolerance. For example, 24±0.25 and 24.5±0.25 are correct.
- When using unilateral tolerances, a single 0 is used without a + or – sign for the 0 part of the value. For example, 24<sup>0</sup><sub>-0.25</sub> and 24<sup>+0.25</sup><sub>0</sub>.
- Basic dimension values follow the same display rules as stated for other metric numbers. For example, 24 and 24.5.

### Placing Inch Dimensions

The following outlines the proper use of inch units on engineering drawings:

- A zero does not precede a decimal inch that is less than one. For example, the inch dimension “.5” has no zero before the decimal point.
- A specified inch dimension is expressed to the same number of decimal places as its tolerance. Zeros are added to the right of the decimal point if needed. For example, the inch dimension .250 ± .005 has an additional zero added to .25.
- Fractional inches can be used, but they generally indicate a larger tolerance. Fractions can be used to give nominal sizes, such as in a thread callout.
- Plus and minus values of an inch tolerance have the same number of decimal places. Zeros are added to fill in where needed. For example, .250<sup>+0.005</sup><sub>-0.010</sub> and  $\begin{matrix} .255 \\ .240 \end{matrix}$ .
- Unilateral tolerances use the + and – symbols, and the 0 value has the same number of decimal places as the value that is greater or less than 0. For example, .250<sup>+0.005</sup><sub>-0.000</sub> and .250<sup>+0.000</sup><sub>-0.005</sub>.
- Inch limit tolerance values have the same number of decimal points. When limit tolerance values are displayed on one line, such as 1.000–1.062, the lower value precedes the higher value, and the values are separated with a dash. When limit tolerance values are displayed stacked, such as  $\begin{matrix} 1.062 \\ 1.000 \end{matrix}$ , the higher value is placed above the lower value.
- Basic dimension values are not required to have the same number of decimal places as their associated tolerance. For example, a geometric tolerance of .005 might have a basic dimension of 2.

### Placing Angular Dimensions

The following outlines the proper use of angular units on engineering drawings:

- Angular dimensions are established in degrees (°) and decimal degrees (30.5°), or in degrees (°), minutes (′), and seconds (″). For example, 24°15′30″.
- Both the plus and minus tolerance values and the angle have the same number of decimal places. For example, 30.0°±0.5°, not 30°±0.5°.
- Where only minutes or seconds are specified, the number of minutes or seconds is preceded by 0° or 0°0′, as applicable. For example, 0°45′30″ and 0°0′45″.

### Using Fractions

Fractions are used on engineering drawings, but they are not as common as decimal inches or millimeters. Fractions are typically used on architectural, structural, and other construction-related drawings. Fraction dimensions generally mean a larger tolerance than decimal numerals when used on engineering drawings. When fractions are used on a drawing, the fraction





FIGURE 10.19 Numerals in fractions. © Cengage Learning 2012

numerals should be the same size as other numerals on the drawing. The fraction bar should be drawn in line with the direction the dimension reads. For unidirectional dimensioning, the fraction bars are all horizontal. For aligned dimensioning, the fraction bars are horizontal for dimensions that read from the bottom of the sheet and vertical for dimensions that read from the right. The fraction numerals should not be allowed to touch the fraction bar. In a few situations—for example, when a fraction is part of a general note, material specification, or title—the fraction bar can be placed diagonally, as shown in Figure 10.19. This is also a common practice using CADD, although fractions can easily be placed as previously described. The ASME standard is not specific about the use of fractions. The previous recommendations are preferred by most companies, but the actual practice depends on company and school standards.

### Arrowheads

Arrowheads are used to terminate dimension lines and leaders. Properly drawn arrowheads should be three times as long as they are wide. All arrowheads on a drawing should be the same size. Do not use small arrowheads in small spaces. Limited-space dimensioning practice is covered later in this chapter (see Figure 10.20).

Individual company preference indicates if arrowheads are filled in solid or left open as shown in Figure 10.20. Most companies prefer the appearance of the filled-in arrowhead. The filled-in arrowheads look better and make the dimension easier to read.

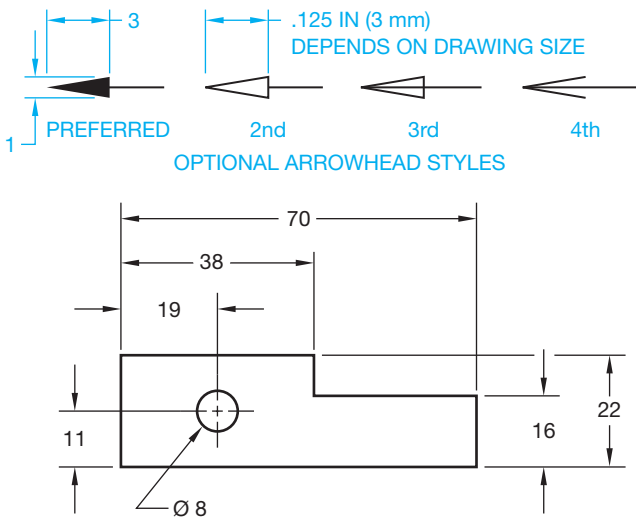


FIGURE 10.20 Arrowheads. © Cengage Learning 2012

### Dimension Line Spacing

Dimension lines are drawn parallel to the feature or object being dimensioned. Dimension lines should be placed at a uniform distance from the object, and all succeeding dimension lines should be equally spaced. The first dimension line should be a minimum of .375 in. (10 mm) from the object, and the second dimension line should be a minimum distance of .25 in. (6 mm) from the first dimension line. All additional dimensions lines should be spaced equally, with the same space as the distance from the first to second dimension line. Figure 10.21 shows the minimum acceptable distances for spacing dimension lines.

In actual practice, the minimum distance is normally too crowded. Judgment should be used based on space available and information presented. Never crowd dimensions, if possible. Drafters typically prefer a distance of .5–1.0 in. (12–24 mm) and a spacing of .5–.75 in. (12–20 mm) for the following dimension lines. The first dimension line is normally spaced farther from the object than the spacing for additional dimension lines. Always place the smallest dimensions closest to the object and progressively larger dimensions outward from the object. Group dimensions and place dimensions between views when possible (see Figure 10.21).

### Relationship of Dimension Lines to Numerals

Dimension numerals are centered on the dimension line unless another placement is necessary. Alternate options are discussed later in this chapter. Numerals are commonly all the same height and are lettered horizontally (unidirectionally). A space equal to at least half the height of lettering should be provided between numerals in a tolerance. The actual space between the numerals in a tolerance is determined by your CADD program, but some programs allow the space to be adjusted. The numeral, dimension line, and arrowheads should be placed between extension lines when space allows. When space is limited, other options should be used.

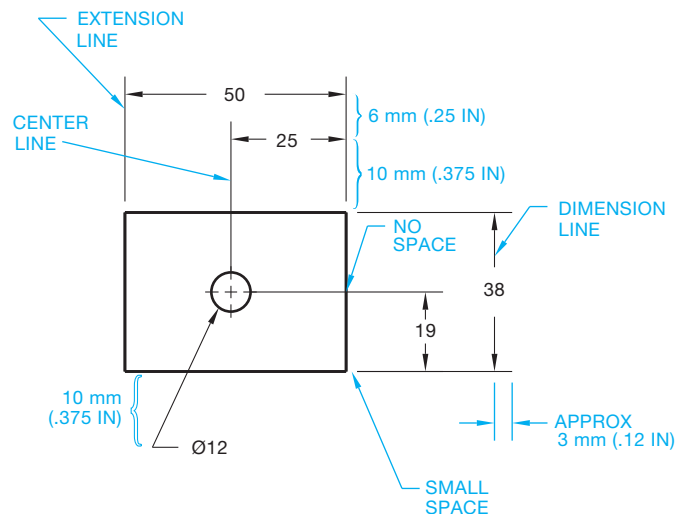


FIGURE 10.21 Minimum dimension line spacing. © Cengage Learning 2012

Figure 10.22 shows several dimensioning options. Evaluate each example carefully as you dimension your own drawing assignments. Figure 10.23 shows some correct and incorrect dimensioning practices. Keep in mind that some computer-aided drafting programs do not necessarily acknowledge all of the rules or accepted examples. Some flexibility on your part is needed to become accustomed to the potential differences that may exist between the recommended applications and the CADD software format.

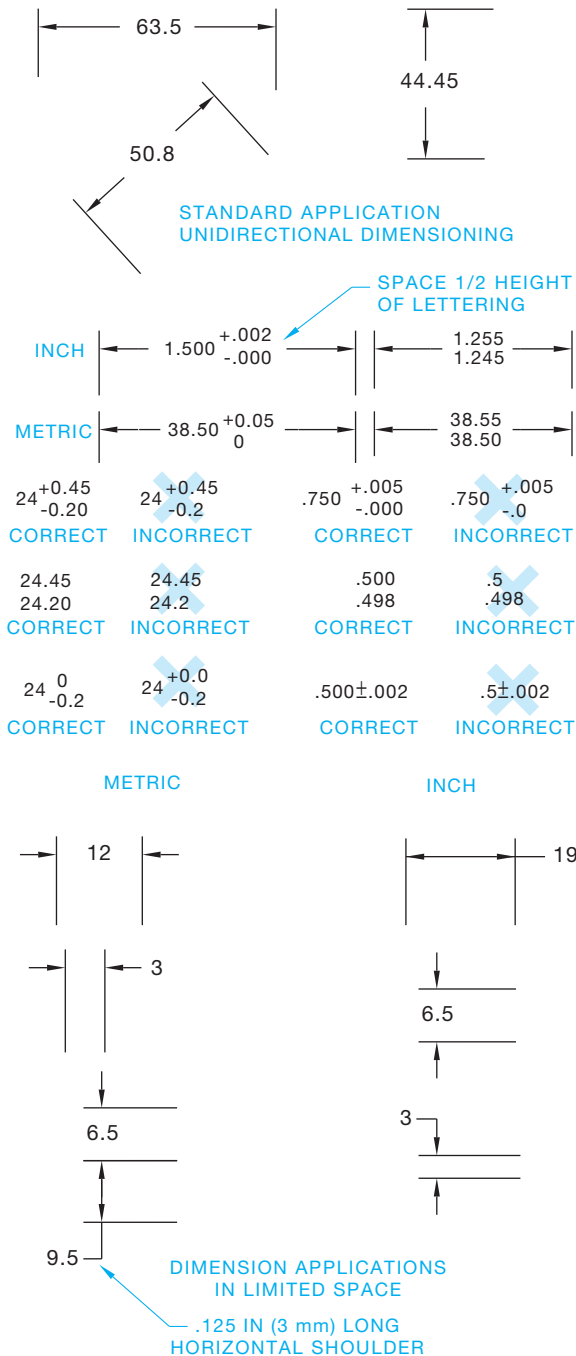


FIGURE 10.22 Dimensioning applications to limited spaces. Metric values are used unless otherwise identified.

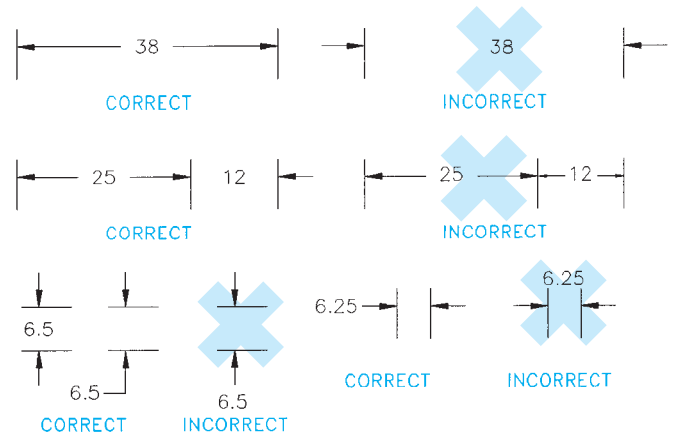


FIGURE 10.23 Correct and incorrect dimensioning practices. © Cengage Learning 2012

### Chain Dimensioning

**Chain dimensioning** also known as **point-to-point dimensioning**, is a methods of dimensioning from one feature to the next. Each dimension is dependent on the previous dimension or dimensions. This is a common practice, although caution should be used as the tolerance of each dimension builds on the next, which is known as **tolerance stacking**, or **buildup**. Figure 10.24 also shows the common mechanical drafting practice of providing an overall dimension while leaving one of the intermediate dimensions blank. The overall dimension is often a critical dimension that should stand independently in relationship to the other dimensions. In addition, if all dimensions are given, then the actual size may not equal the given overall dimension because of tolerance buildup. An example of tolerance buildup is when three chain dimensions have individual tolerances of .15 and each feature is manufactured at or toward the .15 limit: The potential tolerance buildup is three times .15, for a total of .45. The overall dimension has to carry a tolerance of 0.45 to accommodate this buildup. If the overall dimension is critical, such a buildup may not be acceptable. Thus, either one intermediate dimension should be omitted or the overall dimension omitted. The exception to this rule is when a dimension is given only as reference. A **reference dimension** is enclosed in parentheses, as in Figure 10.25a. Figure 10.25b shows the overall dimension of an object as a reference. Chain

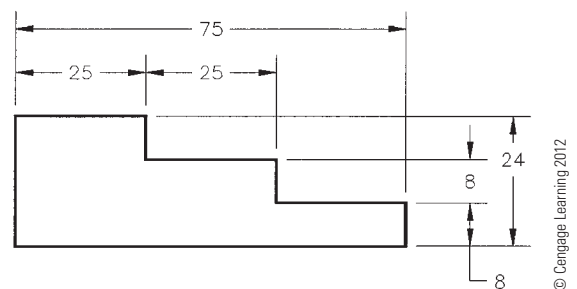


FIGURE 10.24 Chain dimensioning.

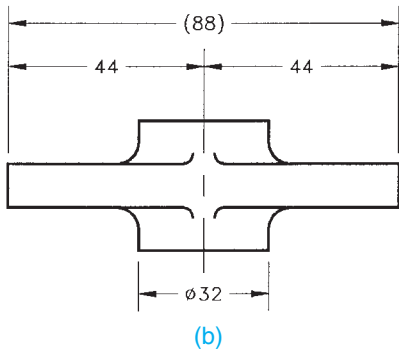
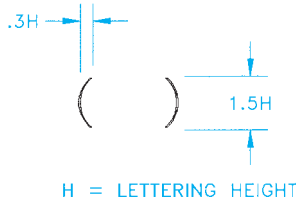
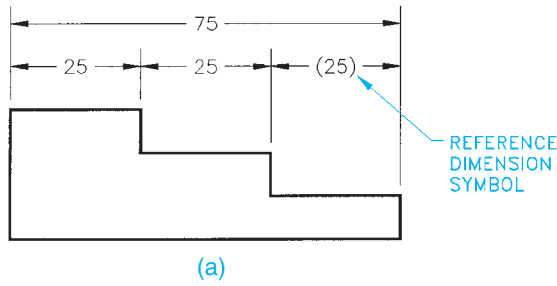


FIGURE 10.25 Reference dimension examples and reference dimension symbol.

dimensioning is commonly used in architectural drafting and related construction industries.

### Baseline Dimensioning

**Baseline dimensioning** is a common method of dimensioning machine parts whereby each feature dimension originates from a common surface, axis, or center plane (see Figure 10.26). Tolerance buildup is less likely to occur than when using chain dimensioning. Baseline dimensioning is used when the size or location of features must be controlled from a common reference plane and less tolerance accumulation is desired. Each dimension in baseline dimensioning is independent, reducing the possibility of tolerance buildup.

Figure 10.27 shows how baseline dimensions can be placed symmetrical about a center plane. Figure 10.27 also shows the use of the symmetrical symbol. In this application, the baseline dimensions originate from the center plane of the part. The symmetrical symbol is used to show that both sides of the object are symmetrical when the object is too large to fit on the sheet and a portion is broken away. A short break line is used to represent the break. While this practice is an option for very large parts, it should be avoided when possible because

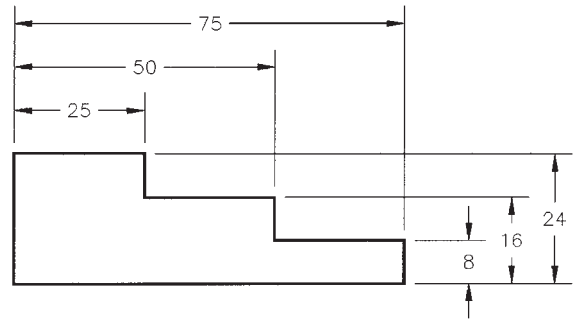


FIGURE 10.26 Baseline dimensioning from a common surface.

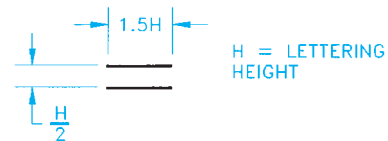
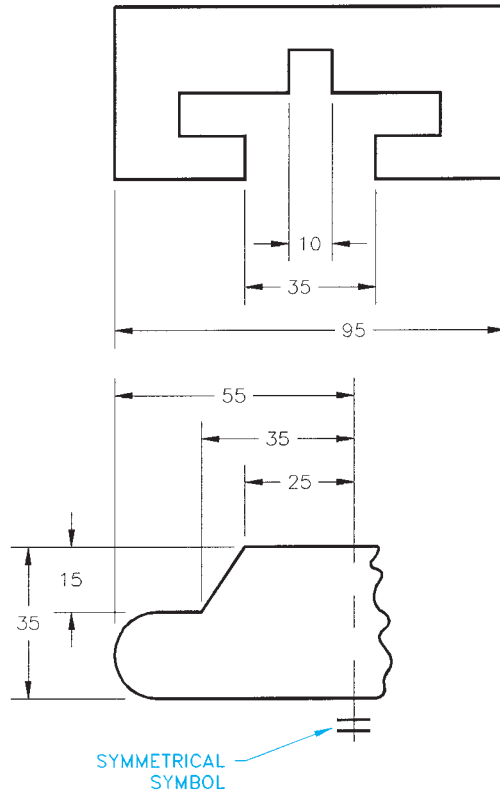


FIGURE 10.27 Baseline dimensioning from center planes and using the symmetrical symbol.

the application can cause confusion. Drawing the entire view on a larger sheet is normally preferred.

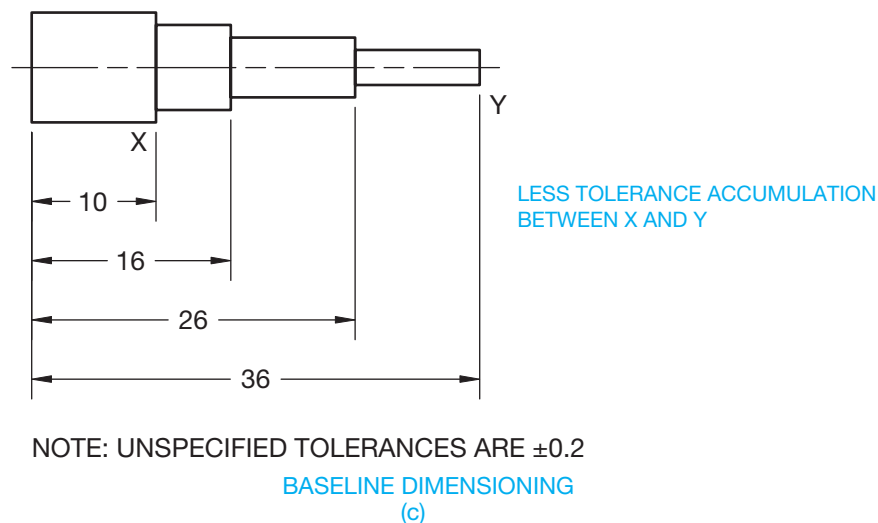
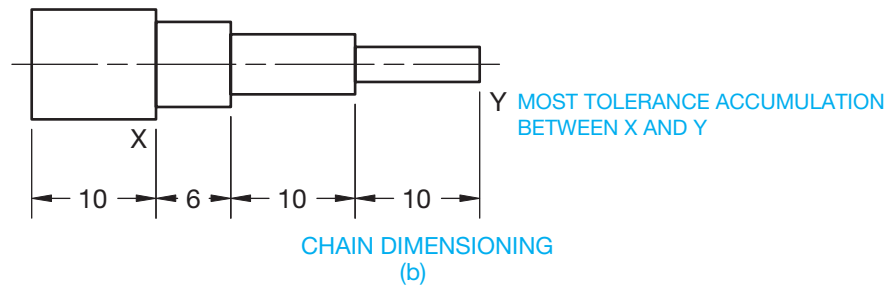
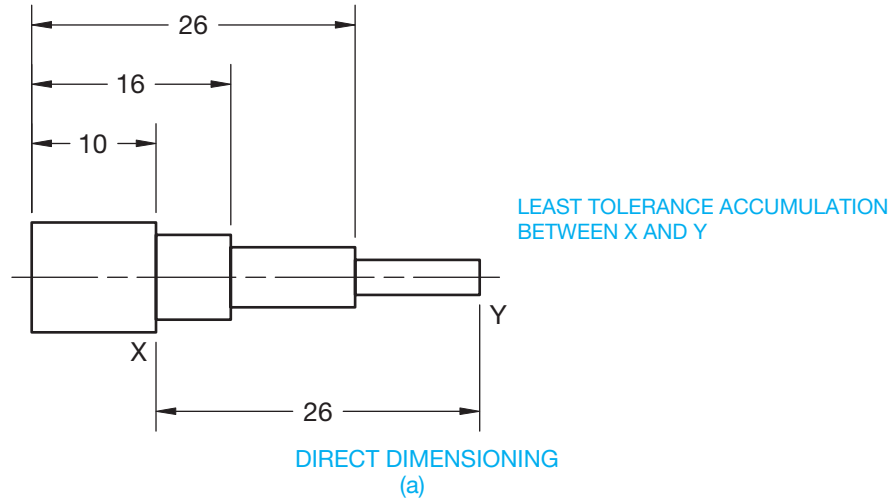
### Direct Dimensioning

**Direct dimensioning** is applied to control the size or location of one or more specific features. The following describes the difference in tolerance buildup between using direct dimensioning, chain dimensioning, and baseline dimensioning.

Baseline dimensioning is used in Figure 10.28a to control the size of three features, and direct dimensioning is used to control the maximum variation of two features by the tolerance on the dimension between the features. This results with direct

dimensioning is the least tolerance buildup where the accumulation between surfaces X and Y is  $\pm 0.2$ .

In contrast, the drawing in Figure 10.28b uses chain dimensioning where the maximum variation between the features is



NOTE: UNSPECIFIED TOLERANCES ARE  $\pm 0.2$

**FIGURE 10.28** A comparison of tolerance buildup between direct, chain, and baseline dimensioning. (a) Direct dimensioning results in the least tolerance buildup. (b) Chain dimensioning results in the most tolerance buildup. (c) Baseline dimensioning results in less tolerance buildup than chain dimensioning but more than direct dimensioning.

© Cengage Learning 2012

the sum of the tolerances controlling the dimensions. In this case, the tolerance accumulation between surfaces X and Y is  $\pm 0.6$ . The drawing in Figure 10.28c uses baseline dimensioning alone where the maximum variation between features is controlled by the sum of the tolerances from the origin to the features. The tolerance accumulation is limited to the possible buildup from the origin to the second and third dimensions between surfaces X and Y, which is  $\pm 0.4$ .

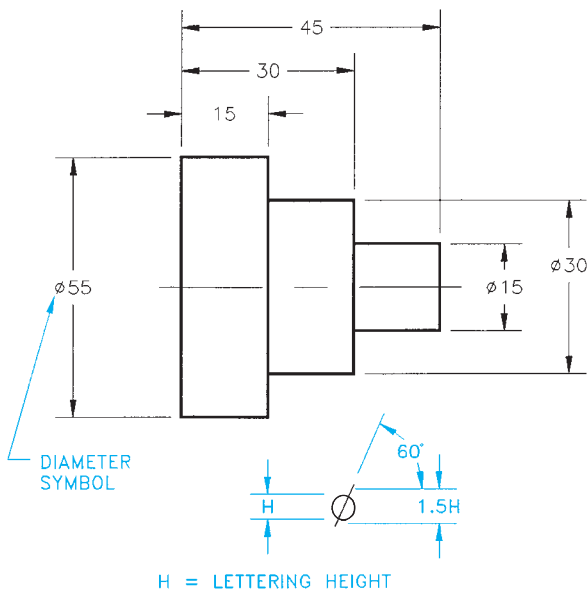
### Staggering Adjacent Dimensions

Notice in Figure 10.27 how dimension numerals are staggered rather than being stacked directly above one another. Always stagger adjacent dimensions when possible. Doing so helps clarity and reduces crowding. To accomplish this, the dimension numeral of some dimensions need to be offset from the center of the dimension line.

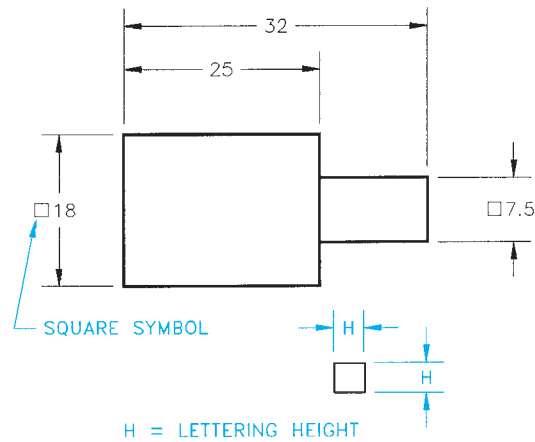
### Dimensioning Symmetrical Objects, Cylinders, and Square Features

Figure 10.24 also shows use of the symmetrical symbol as previously discussed. Both halves of the object are the same. Part of the right side is removed, and a short break line is used to save space. Use this practice only if necessary because it can cause confusion if improperly read. If in doubt and if space permits, draw the entire object.

Dimension cylindrical shapes in the view where the cylinders appear rectangular. The diameters are identified by the diameter symbol, and the circular view can be omitted (see Figure 10.29). Square features are dimensioned in a similar manner using the square symbol shown in Figure 10.30.



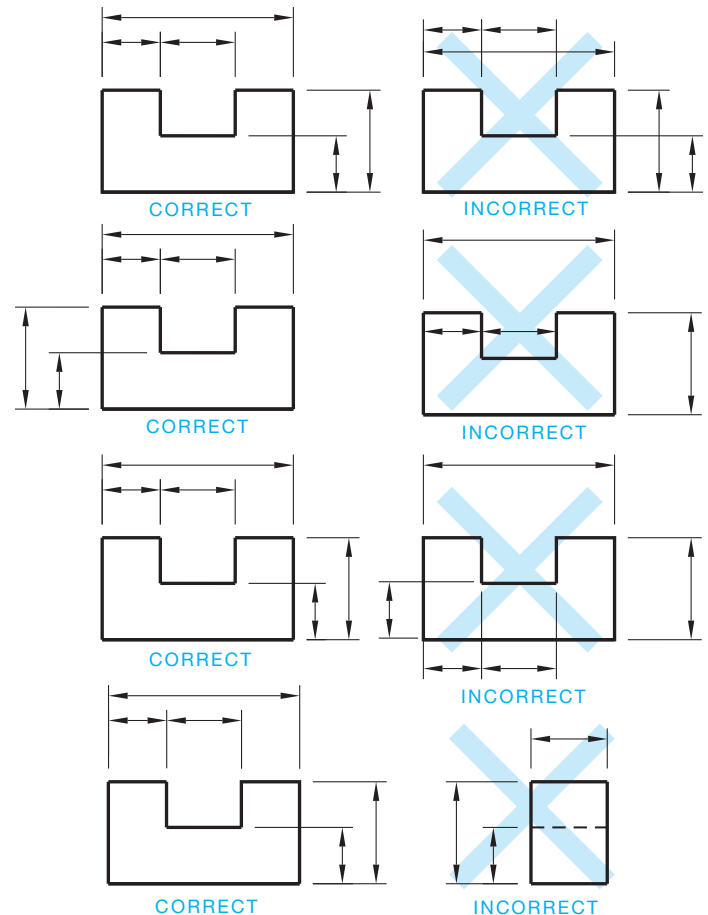
**FIGURE 10.29** Dimensioning cylindrical shapes and using the diameter symbol. *Note:* Some CADD programs do not automatically provide the property sized diameter symbol as shown in this example.



**FIGURE 10.30** Dimensioning square features and the square symbol.

### PREFERRED DIMENSIONING PRACTICES

The drawings in Figure 10.31 show correct and incorrect dimensioning practices. Good judgment should be used when placing dimensions. Basic rules apply to the placement of dimensions, but you will find situations in the real world when it is impossible to follow the rules. When it is necessary to break a



**FIGURE 10.31** Correct and incorrect dimensioning examples. © Cengage Learning 2012

dimensioning rule, do it as wisely as possible while maintaining clarity. The following provides basic guidelines to follow when placing dimensions.

- Avoid crossing extension lines, but *do not* break extension lines when they do cross.
- *Never* cross extension lines over dimension lines. When there is no other solution, break the extension line where it crosses over the dimension line. *Never* break a dimension line.
- Break extension lines when they cross *over or near* an arrowhead, such as when an extension line crosses a leader line near the arrowhead. It is not necessary to break the extension line in other cases. Your CADD drafting application may not allow for breaks in extension lines. Confirm this with your CADD instructions.
- *Avoid* dimensioning over or through the object.
- *Avoid* dimensioning to hidden features.
- *Avoid* unnecessary long extension lines.
- *Avoid* using any line of the object as an extension line.
- Dimension *between* views when possible.
- *Group* adjacent dimensions.
- Dimension to views that provide the *best shape description*.
- *Do not* use a centerline, extension line, phantom line, visible object line, or a continuation of any of these lines as a dimension line.
- *Stagger* adjacent dimension numerals so they do not line up.

## Dimensioning Angles

**Angular surfaces** can be dimensioned as coordinates, as angles in degrees, or as a flat taper (see Figure 10.32). Angles are measured in degrees using the degree symbol ( $^{\circ}$ ). There are  $360^{\circ}$  in a circle. Each degree contains 60 minutes. Minutes are identified with the minute symbol ( $'$ ). Each minute has 60 seconds, identified with the seconds symbol ( $''$ ). The following is the breakdown of degrees, minutes, and seconds:  $1^{\circ} = 60'$  and  $1' = 60''$ . When using the angular method of dimensioning an angle, notice in Figure 10.32 that the dimension line for the  $45^{\circ}$  angle is drawn as an arc. The radius of this arc is centered at the vertex of the angle.

## Dimensioning Chamfers

A **chamfer** is a slight surface angle used to relieve a sharp corner. Chamfers of  $45^{\circ}$  are dimensioned with a note, while other chamfers require an angle and size dimension, or two size dimensions as shown in Figure 10.33. A note is used on  $45^{\circ}$  chamfers because both sides of a  $45^{\circ}$  angle are equal. When placing the  $45^{\circ}$  chamfer note, the size is followed by the (X) symbol and then the  $45^{\circ}$  angle without spaces. For example,  $3X45^{\circ}$ . Both sides of a  $45^{\circ}$  angle are equal. For this reason, another option is to place the value for the dimension of the sides in the note and leave out the  $45^{\circ}$  angle, such as  $3X3$ .

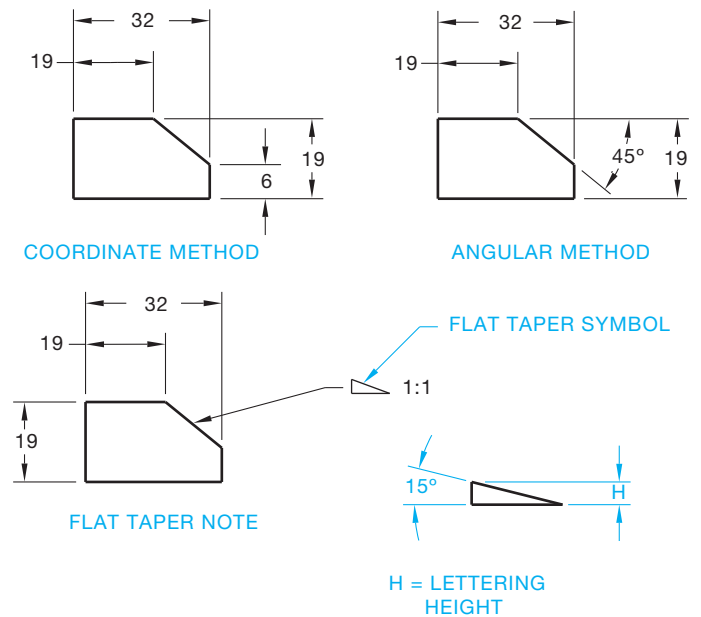


FIGURE 10.32 Dimensioning angular surfaces and flat taper symbol. © Cengage Learning 2012

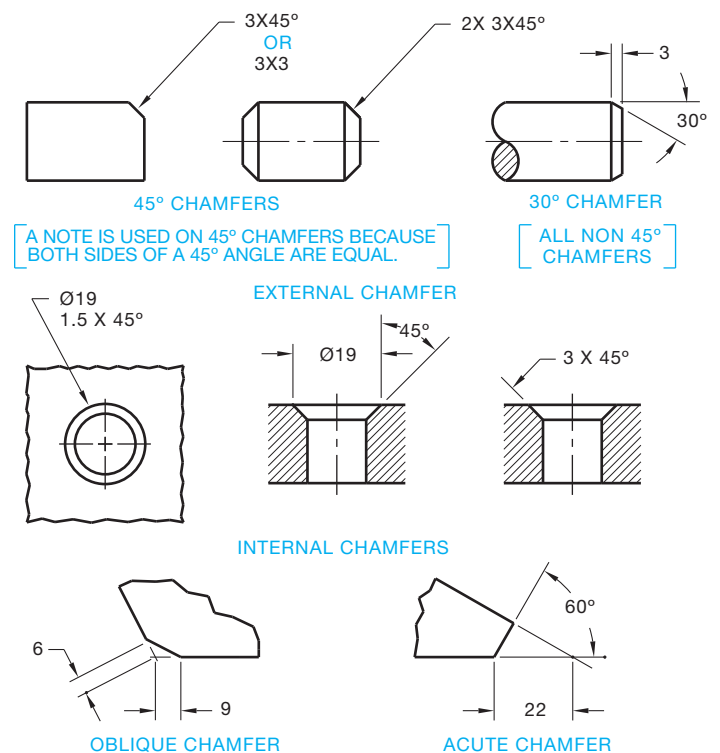


FIGURE 10.33 Dimensioning chamfers. © Cengage Learning 2012

## Dimensioning Conical Shapes

**Conical shapes** should be dimensioned when possible in the view where the cone appears as a triangle as shown in Figure 10.34. The circular view can be omitted because the base is dimensioned with a diameter. A conical taper can be treated in one of three possible ways, as shown in Figure 10.35. The

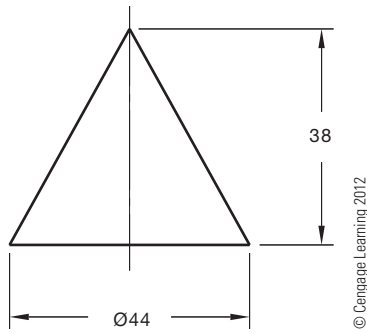


FIGURE 10.34 Dimensioning conical shapes.

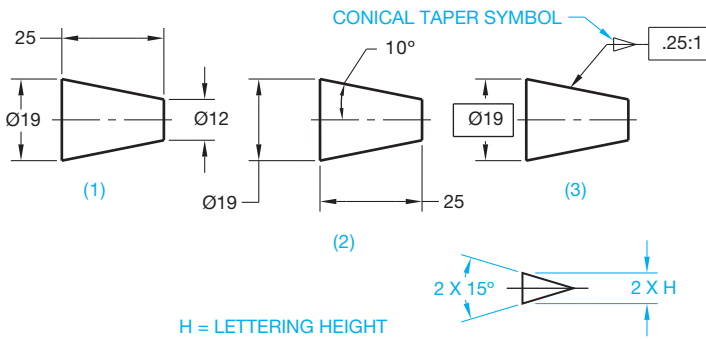


FIGURE 10.35 Dimensioning conical tapers and the conical taper symbol.

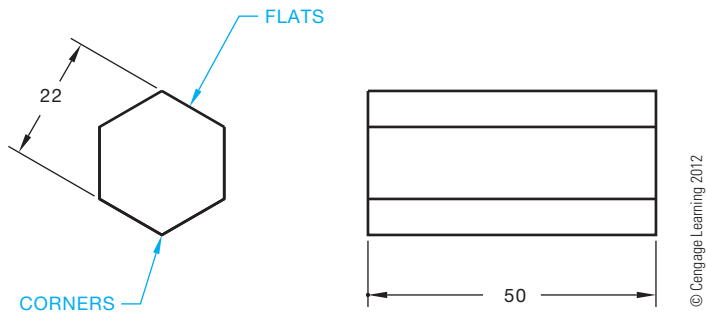


FIGURE 10.36 Dimensioning hexagons.

circular views are omitted in these examples. Notice the use of the conical taper symbol as an option in Figure 10.35.

### Dimensioning Hexagons and Other Polygons

Dimension hexagons and other polygons across the flats in the views where the true shape is shown. Provide a length dimension in the adjacent view as shown in Figure 10.36.

### Dimensioning Arcs

**Arcs** are dimensioned with leaders and radius dimensions in the views where they are shown as arcs. The leader can extend from the center to the arc or point to the arc as shown in Figures 10.37 and 10.38. The letter *R* precedes all radius dimension values. Depending on the situation, arcs can be dimensioned

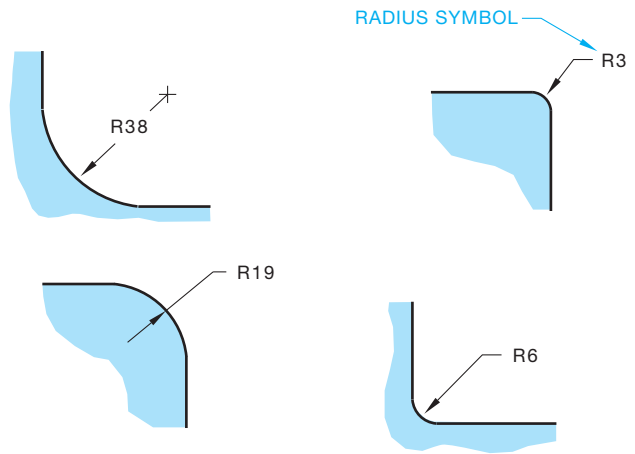


FIGURE 10.37 Dimensioning arcs with no centers located and using the radius symbol.

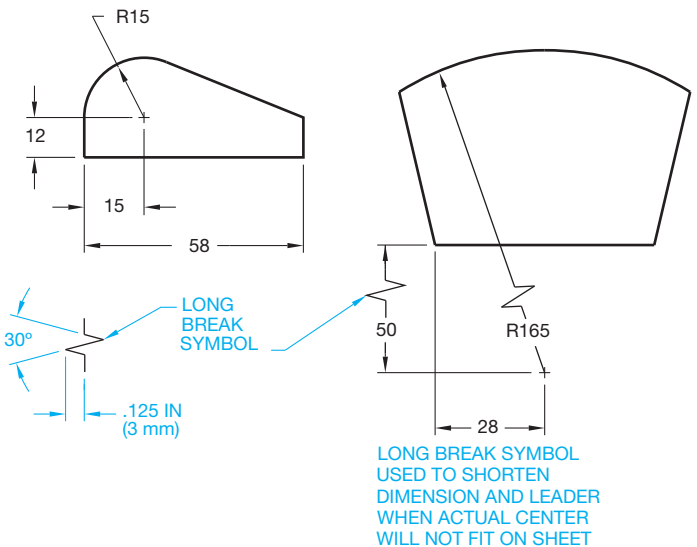


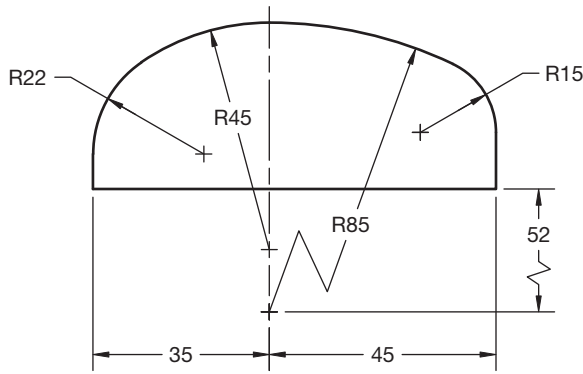
FIGURE 10.38 Dimensioning arcs with centers located and using the long break symbol for a very long radius dimension.

with or without their centers located. It is common to leave the center marks off small arcs and the arc center location is not dimensioned. This depends on the specific application and the company or school preference.

Figure 10.38 shows a very large arc with the center moved closer to the object. To save space, a break line is used in the leader and in the shortened locating dimension to indicate that the dimension is not in true length. The given dimension value is the accurate location dimension.

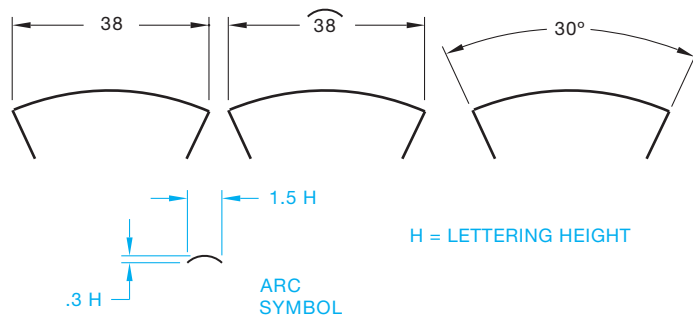
A design can be created that has a series of tangent arcs. When this is done, the curved outline made up of two or more arcs is dimensioned by providing the radii of all arcs and locating the arc centers with coordinate dimensions as shown in Figure 10.39.

Providing an arc length is an optional dimensioning application for an arc. The arc length can be dimensioned one of three ways as shown in Figure 10.40. Notice the detailed drawing of the arc length symbol for use in one of the options in Figure 10.40.

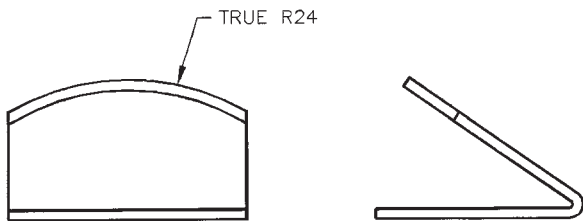


© Cengage Learning 2012

**FIGURE 10.39** Defining a curve with continuous radii. The center for the radius of each arc is located.



**FIGURE 10.40** Dimensioning arc length and using the arc symbol.  
© Cengage Learning 2012



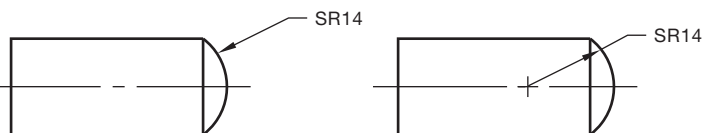
© Cengage Learning 2012

**FIGURE 10.41** Dimensioning a true radius in an inclined plane.

In a situation in which an arc lies on an inclined plane and the true representation is not shown, the note TRUE R is used to specify the actual radius. However, dimensioning the arc in an auxiliary view of the inclined surface is better, if possible (see Figure 10.41).

The symbol CR refers to controlled radius. Controlled radius means the limits of the radius tolerance zone must be tangent to the adjacent surfaces, and there can be no reversals in the contour. The CR control is more restrictive than use of the R radius symbol where reversals in the contour of the radius are permitted.

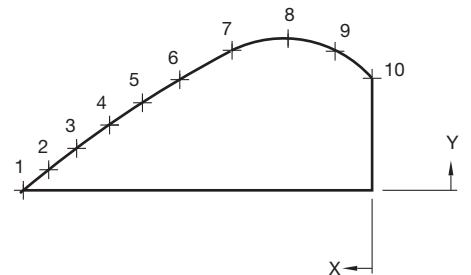
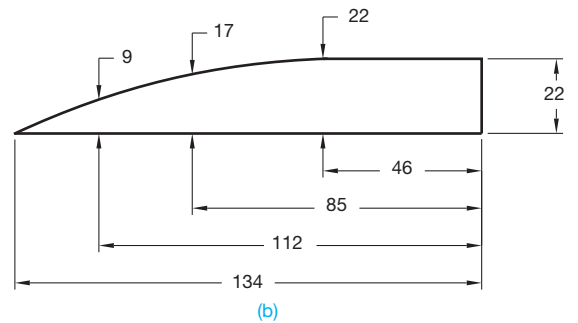
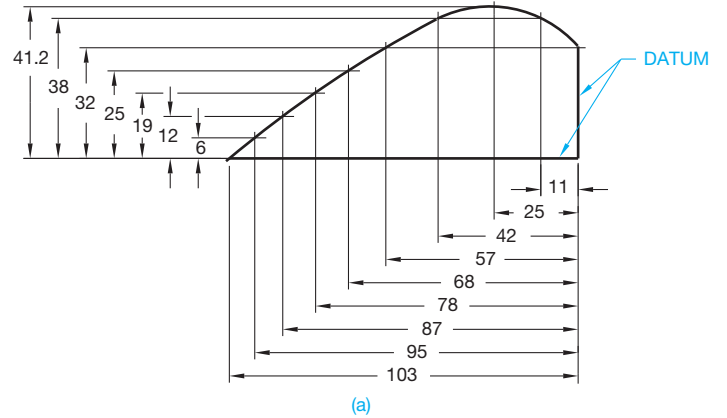
A spherical radius is dimensioned with the abbreviation SR in front of the numerical value as shown in Figure 10.42.



**FIGURE 10.42** Dimensioning a spherical radius. © Cengage Learning 2012

## Dimensioning Contours Not Defined as Arcs

An arc can be drawn without a defined radius in some design applications. An example is a curved contour. Coordinates or points along the contour are located from common surfaces as shown in Figure 10.43a. Another option is to place a series of dimensions on the object and along the contour. Additional dimensions are placed from a common surface to

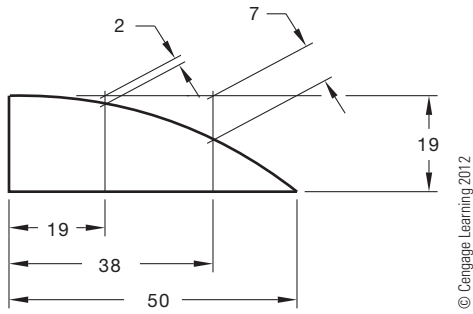


POINT	1	2	3	4	5	6	7	8	9	10
X	-103	-95	-87	-78	-68	-57	-42	-25	-11	0
Y	0	6	12	19	25	32	38	41	38	32

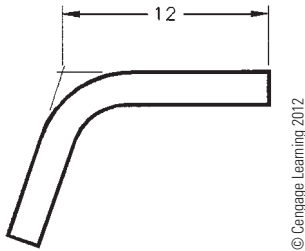
(c)

**FIGURE 10.43** Dimensioning contours not defined as arcs. (a) Dimensioning a series of points along the contour using baseline dimensions from common surfaces. (b) Dimensioning points along a contour using an alternate method. (c) Dimensioning points along a surface using tabular dimensioning. © Cengage Learning 2012





**FIGURE 10.44** Dimensioning a curved contour using oblique extension lines.



**FIGURE 10.45** Locating a point established by extension lines.

each of the previous dimensions. The dimension lines of the first set of dimensions are used as extension lines for the second set of dimensions. This application is an option, but it is not as practical as other options and it violates the rule of using a dimension line as an extension line. Another option is the placement of a series of points along the contour and dimension the points using tabular dimensioning as shown in Figure 10.43c.

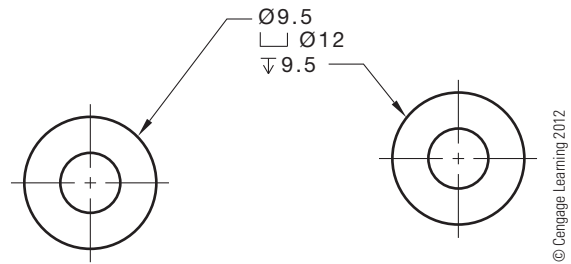
Figure 10.44 shows a curved contour dimensioned using oblique extension lines. Although this technique can be used, it is not as common as using vertical and horizontal coordinate dimensions. The use of oblique extension lines can be considered when space is limited and the oblique extension lines clearly show where they apply.

### Locating a Point Established by Extension Lines

If the sides of the object in Figure 10.45 are extended beyond the bend, they meet at the intersection of the extension lines. This imaginary point is where the dimension often originates in this type of situation.

## NOTES FOR MACHINED FEATURES

Machined features such as holes, counterbores, countersinks, threads, and slots are commonly dimensioned using a leader connected to the feature and a related note.



**FIGURE 10.46** Leader orientation to the note. Center leader shoulder at beginning or end of the note text.



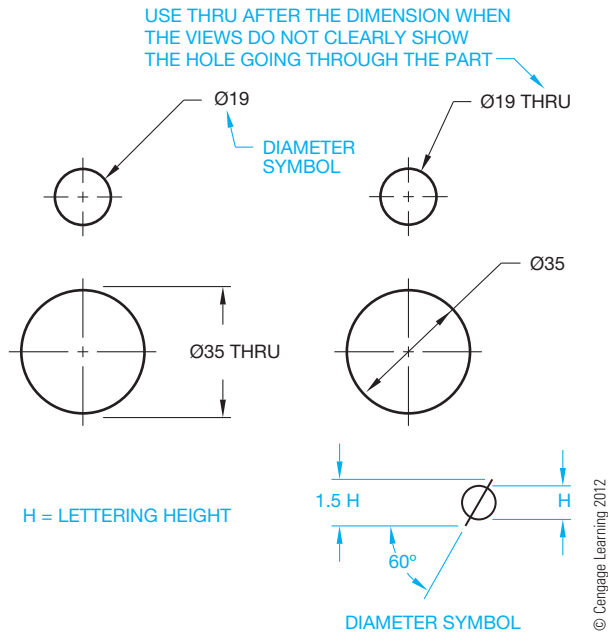
**FIGURE 10.47** Leader orientation to the circle. Leader arrow should point to center.

## Dimensioning Holes

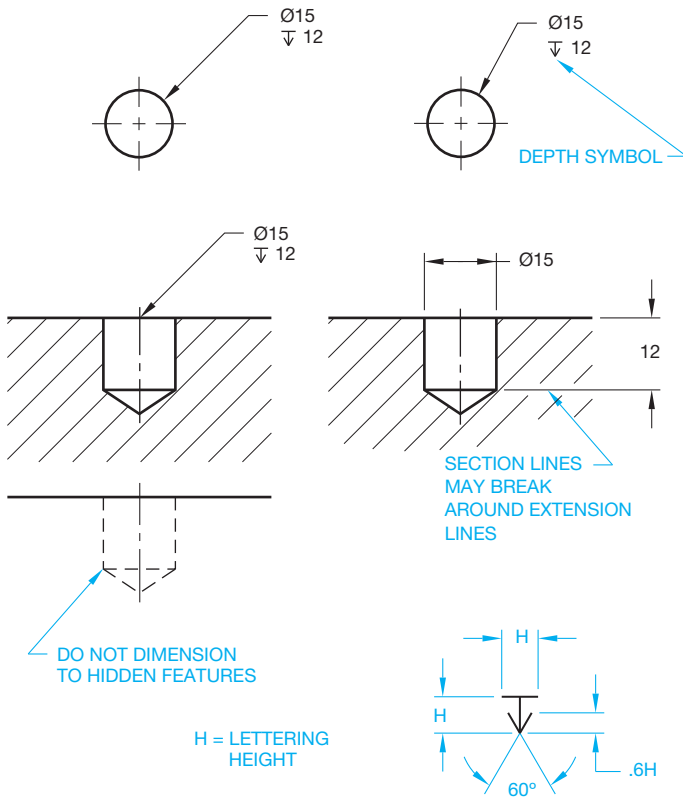
Hole sizes are dimensioned with leaders to the view where they appear as circles, or dimensioned in a sectional view. When leaders are used to establish notes for holes, the shoulder should be centered on the beginning or the end of the note. When a leader begins at the left side of a note, it should originate at the beginning of the note. When a leader begins at the right side of a note, it should originate at the end of the note as shown in Figure 10.46.

Figure 10.47 shows the leader touching the circumference of the circle. The correct application shows that the leader would intersect the center of the circle if it were to continue. Notice the incorrect application on the right. Most CADD programs automatically connect leaders to circles using the correct method. Leaders can be drawn at any angle, but 45° is the preferred angle. Leaders drawn between 15° and 75° from horizontal are acceptable. Do not draw horizontal or vertical leaders.

The diameter symbol precedes all dimensions for circular features as shown in Figure 10.48. The properly drawn diameter symbol is shown in Figure 10.48. A hole through a part can be noted with the word THRU following the numeral, if it is not obvious that the hole goes through. If a hole does not go through the part, the depth must be noted in the circular view or in section as shown in Figure 10.49. The properly drawn depth symbol is also shown in Figure 10.49. It is not necessary to specify the machining process with the hole diameter. Holes are commonly machined with a drill that creates a conical point at the bottom of the hole. The conical drill end is drawn using a 120° included angle (see Figure 10.49).



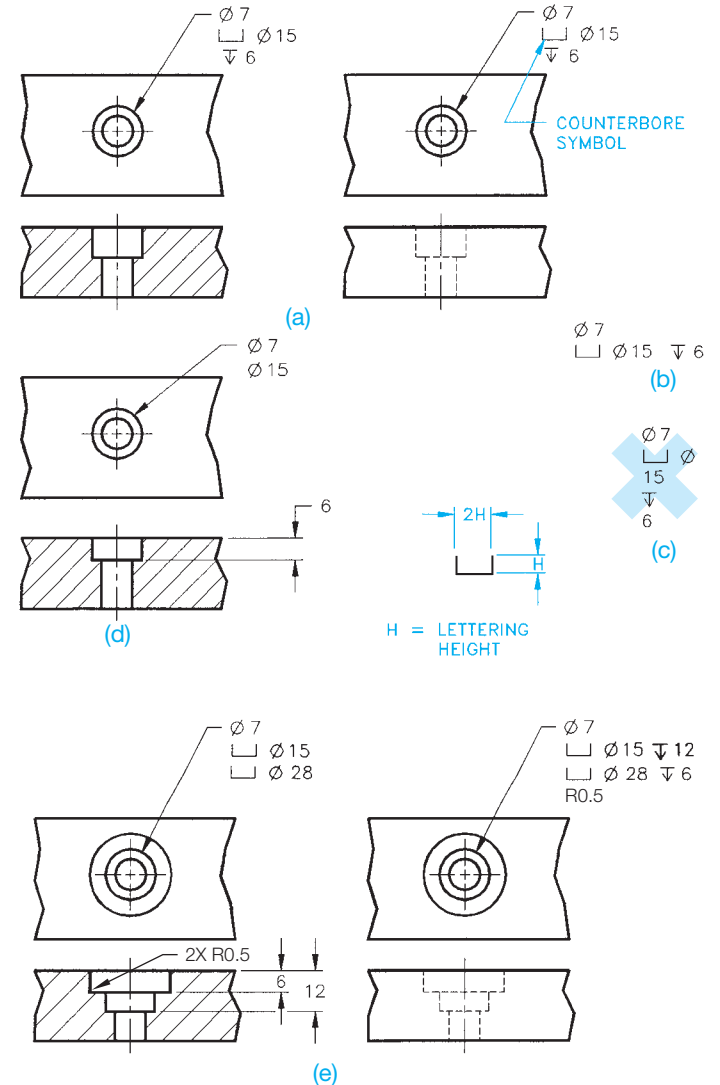
**FIGURE 10.48** Dimensioning hole diameters and using the diameter symbol.



**FIGURE 10.49** Dimensioning hole diameters and depths and using the depth symbol. The machine process, such as DRILL, is not given in the note. © Cengage Learning 2012

## Dimensioning a Counterbore

A **counterbore** is often used to machine a diameter below the surface of a part so a bolt head or other fastener can be recessed. Counterbore and other similar notes are given in the order of machine operations with a leader in the view where they appear as circles. The properly drawn counterbore symbol is detailed in Figure 10.50. The counterbore note is normally stacked and uses the order of small hole diameter, followed by the counterbore symbol and diameter, followed by the counterbore depth

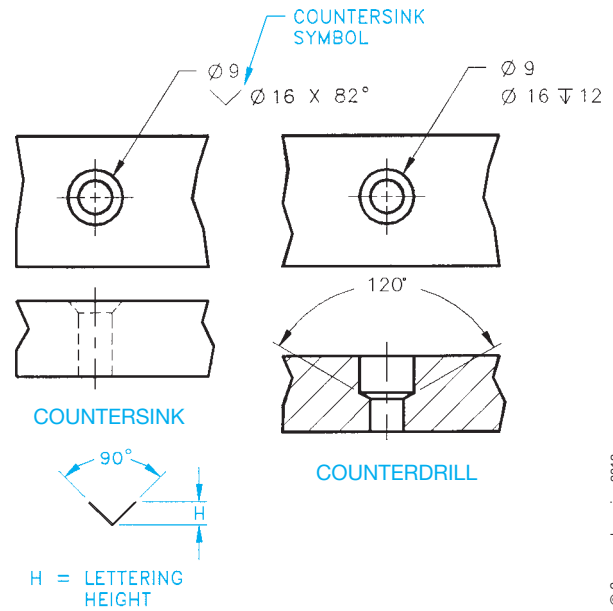


**FIGURE 10.50** Counterbore note applications. (a) Typical counterbore note. (b) Alternate counterbore note with elements of note grouped on one line. (c) Never split individual note elements. (d) Dimensioning the counterbore depth in a sectional view. (e) Dimensioning multiple counterbore depths. The proper counterbore symbol is also displayed. The radius at the bottom of a counterbore can be dimensioned if required. The radius value is placed after the counterbore depth in the note or dimensioned directly in a sectional view. © Cengage Learning 2012

(see Figure 10.50a). Figure 10.50b shows an alternate note format with the elements in a line. Figure 10.50c shows an incorrect counterbore note format. The counterbore diameters can be dimensioned with a leader in the circular view and the depth given in a sectional view as shown in Figure 10.50d. Multiple counterbores are dimensioned in a similar manner as shown in Figure 10.50e. A radius value can be specified on the inside of the counterbore where the side meets the bottom of the counterbore. This radius value on the inside of the counterbore can be put in the note following the depth or in a sectional view as shown in Figure 10.50e.

**STANDARDS**

**ASME** The ASME Y14.5-2009 standard recommends that the elements of each note shown in Figures 10.50 through 10.53 be aligned as shown. However, because of individual preference or drawing space constraints, the elements of the note can be confined to fewer lines as shown in Figure 10.50b. *Never separate individual note components as shown in Figure 10.50c.*



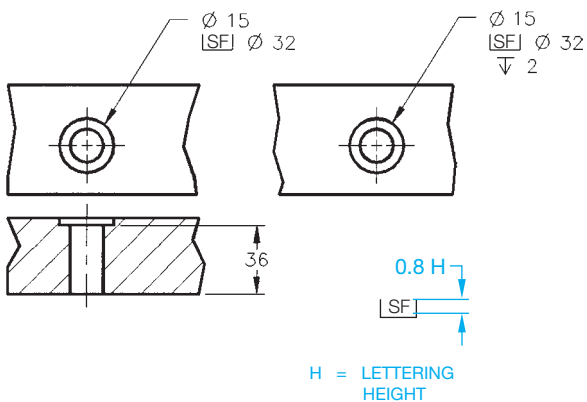
**FIGURE 10.52** Countersink and counterdrill notes with dimensions. The properly drawn countersink symbol is also shown.

© Cengage Learning 2012

**Dimensioning a Spotface**

A **spotface** is used to provide a flat bearing surface for a washer face or bolt head. The spotface is similar in appearance to the counterbore, except that the spotface depth is generally shallow, such as .06 in. (1.5 mm) (see Figure 10.51). The spotface symbol is also the same as the counterbore symbol, except SF is placed in the symbol. Follow the counterbore guidelines when lettering the spotface note. The radius value at the bottom of the spotface can also be put in the spotface note.

**NOTE:** The diameter of a counterbore is the outside diameter and the cylinder that forms the counterbore diameter, and the diameter of a spotface is the diameter of the flat surface formed by the diameter value.



**FIGURE 10.51** Spotface note and dimensioning options. The proper spotface symbol is also displayed.

© Cengage Learning 2012

**Countersink or Counterdrill**

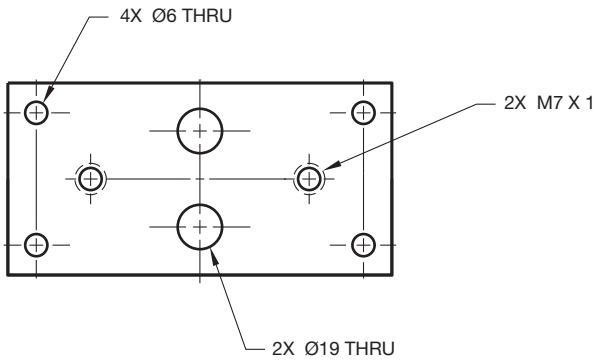
A **countersink** or **counterdrill** is used to recess the head of a fastener below the surface of a part. The countersink specifications are designed to match the fastener head to be used in the application. The order of elements in the note are hole diameter, followed by the countersink symbol, countersink diameter, followed by the *by* symbol (X) and the included angle of the countersink. The counterdrill uses a smaller drill followed by a larger drill to a specified depth. The bottom of the larger drill has the 120° included angle of a drill point (see Figure 10.52). The countersink symbol is detailed in Figure 10.52.

**Dimensioning Multiple Features**

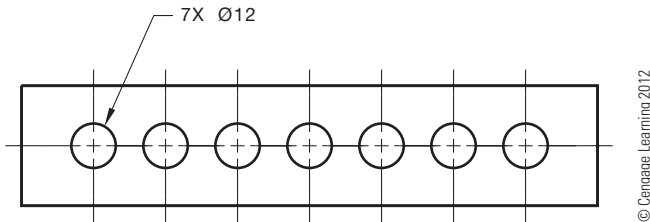
When a part has more than one feature of the same size, the features are dimensioned with a note specifying the number of like features as shown in Figure 10.53. For example, specify the number of features such as 4 followed by the *by* symbol (X), followed by a space and then the feature specification, resulting in this note: 4X Ø6 THRU. The method shown in Figure 10.54 is used if a part contains several same size features.

**Dimensioning Slots**

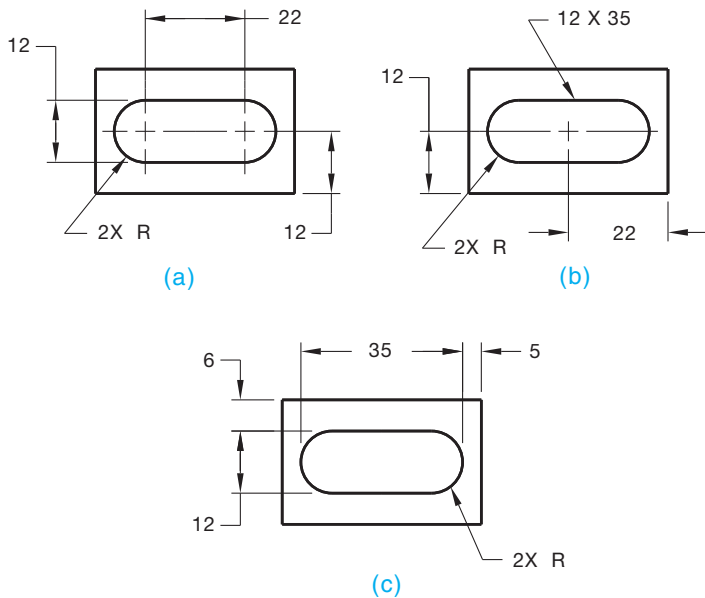
**Slotted features** can be dimensioned in one of three ways, as shown in Figure 10.55. The slot dimensioning practice shown in Figure 10.55a is generally used when milling is the desired



**FIGURE 10.53** Dimension notes for multiple features. The number of like features is placed first, followed by the *by* symbol (X), followed by a space and the diameter dimension is placed last.

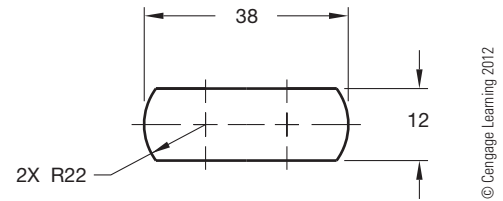


**FIGURE 10.54** Dimension notes for multiple features all of common size.



**FIGURE 10.55** Dimensioning slotted holes with full radius ends.  
© Cengage Learning 2012

machining process. Figure 10.55b displays the normal dimensioning practice when using a punching process to make slotted holes. The preferred slot dimensioning practice for the laser-cutting process is shown in Figure 10.55c. These methods are



**FIGURE 10.56** Dimensioning slot or external feature with end radius larger than feature width.

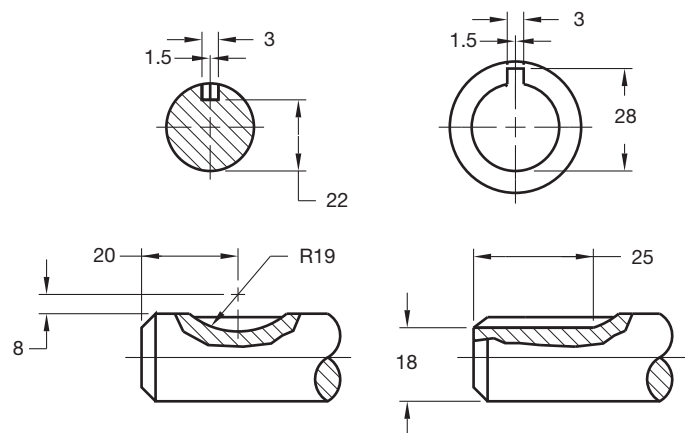
used only when the ends are fully rounded and tangent to the sides. In Figure 10.55, notice the note dimensioning the slot ends reading: 2X R. The 2X means there are two radii, one on each end, followed by a space and the letter R. R is the radius note, and no size is given because a full radius is assumed. When the ends of a slot or external feature have a radius greater than the width of the feature, then the size of the radius must be given, as shown in Figure 10.56.

### Dimensioning Keyseats and Keyways

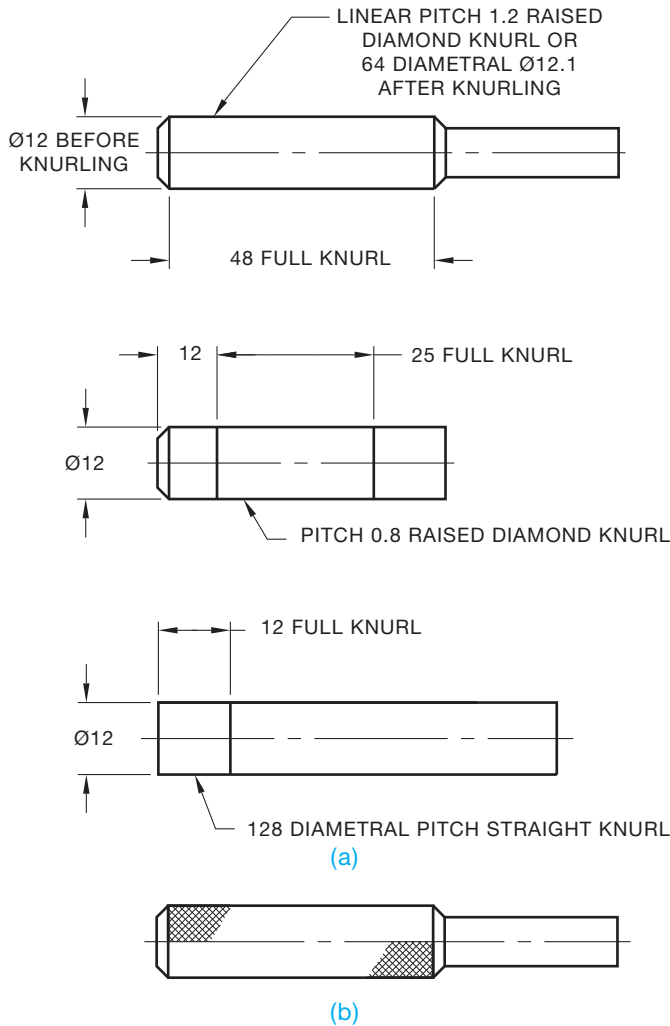
**Keyseats** and **keyways** are dimensioned in the view that clearly shows their shape by width, depth, length, and location as shown in Figure 10.57. A sectional view is often used to expose the feature for dimensioning. Finding specifications for keyseats and keyways is described in Chapter 16, *Mechanisms: Linkages, Cams, Gears, and Bearings*.

### Dimensioning Knurls

**Knurling** is a cold forming process used to form a cylindrical or flat surface uniformly with a diamond or straight pattern creating a knurl. Knurls are dimensioned with notes

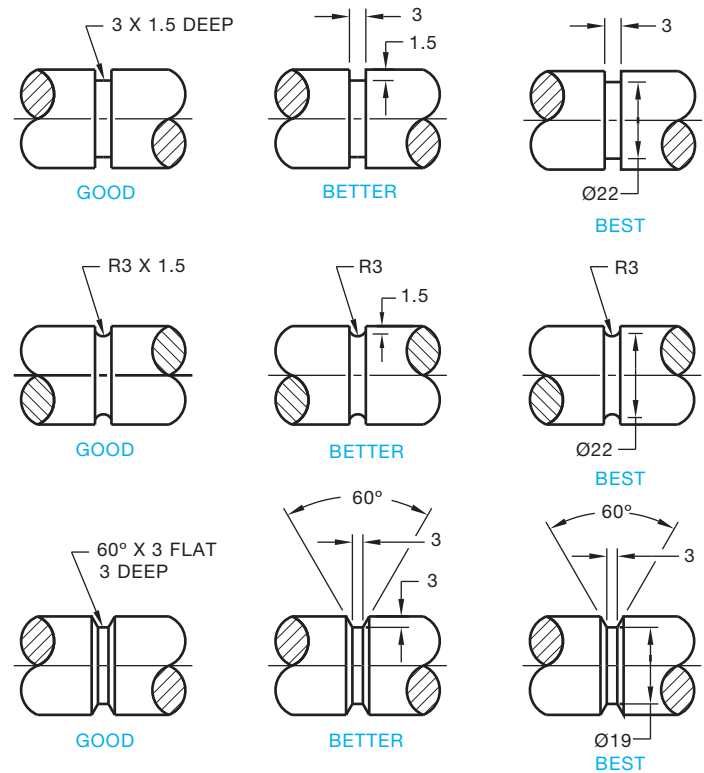


**FIGURE 10.57** Dimensioning keyseats. © Cengage Learning 2012



**FIGURE 10.58** Dimensioning knurls. (a) The recommended ASME method for dimensioning knurls. (b) Optional knurl representation. © Cengage Learning 2012

and leaders pointing to the knurl in the rectangular view as shown in Figure 10.58a. A knurling process is dimensioned with the type of knurl, such as diamond or straight, and the diameter before or after knurling. The diameter before or after knurling is omitted, if not required. The knurl **pitch** or **diametral pitch** is also given in the note. The pitch is the distance from the crest of one knurl form to the crest on the next knurl form. The pitch can also be referred to as *linear pitch*. The diametral pitch is a value found by dividing the total number of teeth in the circumference by the nominal diameter. When dimensioning knurls that are decorative or used for gripping, such as a thumb screw, it is recommended to give the dimension and tolerance and state **BEFORE KNURLING**. For knurls used to press fit into another part, the tolerance diameter of the feature should be specified **BEFORE KNURLING**, and the minimum acceptable diameter of the feature should be specified **AFTER KNURLING**. ASME Y14.5-2009 does not recommend showing a knurl



**FIGURE 10.59** Dimensioning options for necks and grooves. © Cengage Learning 2012

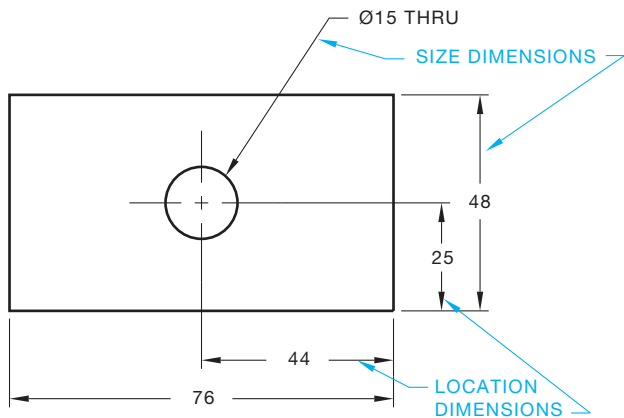
representation on the view as in Figure 10.58b, although some companies prefer this practice to help characterize the knurl on the view.

## Dimensioning Necks and Grooves

Necks and grooves are used for a variety of purposes, including thread relief at a fastener head, the assembly of an O-ring seal, or the insertion of a retaining ring. Necks and grooves are dimensioned as shown in Figure 10.59. This example shows multiple groove characteristics being dimensioned with GOOD, BETTER, and BEST options. In some of the examples, notice the dimensions placed within the objects. Although this method should be avoided, these cases can require this practice. If the extension lines are not too long, it is possible to extend these dimensions through the object to the outside. The use of any of these options and practices should be confirmed with your company or school standards.

## PLACING LOCATION DIMENSIONS

In general, dimensions identify either size or location as shown in Figure 10.60. The previous dimensioning discussions focused on size dimensions. Location dimensions to cylindrical features, such as holes, are given to the center of the feature in the view where the features appear as a circle or in a sectional



© Cengage Learning 2012

FIGURE 10.60 Size and location dimensions.

view. Rectangular shapes are located to their sides, and symmetrical features can be located to their center plane. Some location dimensions also control size.

### Locating Holes

Locate a hole center in the view where the hole appears as a circle as shown in Figure 10.60. The hole centerlines are generally extended beyond the object where centerlines become extension lines. The location dimensions are commonly placed from a surface of the part or from other features.

### Dimensioning Rectangular Coordinates

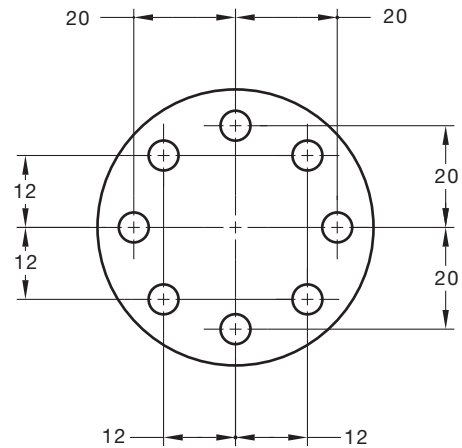
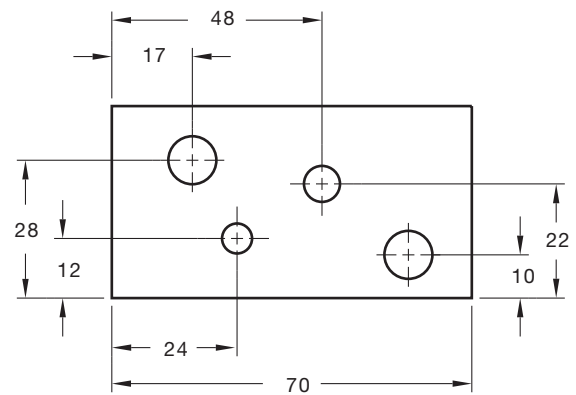
Linear dimensions are used to locate features from planes or centerlines as shown in Figure 10.61. This method is referred to as **rectangular coordinate dimensioning**. Rectangular coordinate dimensioning without dimension lines can also be used as described earlier in this chapter.

### Dimensioning Polar Coordinates

Angular dimensions locate features from planes or centerlines as shown in Figure 10.62. This method is called **polar coordinate dimensioning**. A linear and angular dimension is used to specify the feature location from surfaces or centerlines.

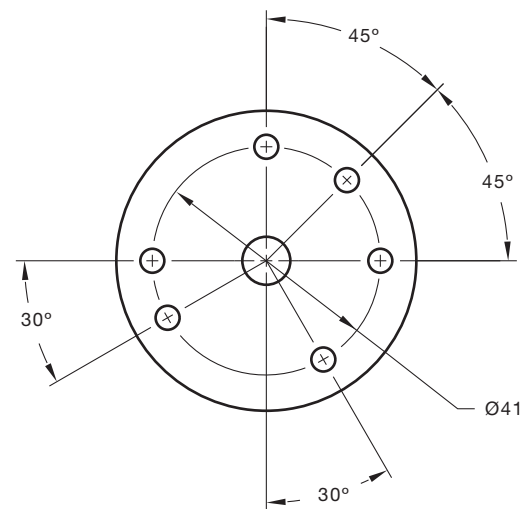
### Dimensioning Repetitive Features

Repetitive features are located by noting the number of times a dimension is repeated and giving one typical dimension and the total length as reference. This method is acceptable for chain



© Cengage Learning 2012

FIGURE 10.61 Rectangular coordinate location dimensions.



© Cengage Learning 2012

FIGURE 10.62 Polar coordinate location dimensions. If all features are equally spaced, a dimension such as 6X 60° can be used at one location.

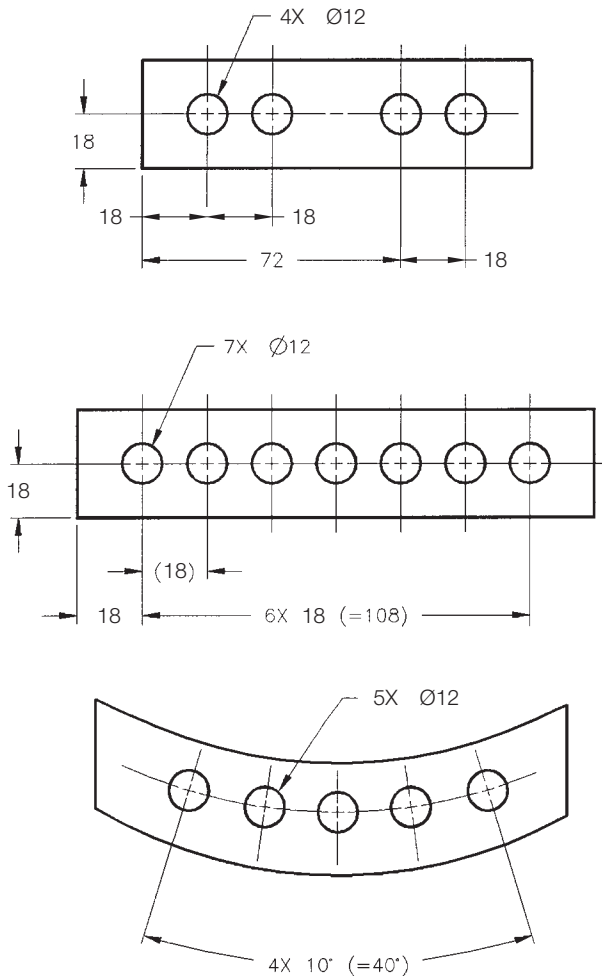


FIGURE 10.63 Dimensioning repetitive features.

dimensioning (see Figure 10.63). If chain dimensioning is not acceptable because of possible tolerance stacking, baseline or direct dimensioning should be used to locate the multiple features. With baseline dimensioning, each feature is dimensioned independently from a common surface or other feature and tolerance stacking is reduced.

### Locating Multiple Tabs in a Polar Orientation

Locating multiple tabs in a polar orientation is shown in Figure 10.64. This method also works for locating multiple slots in a polar orientation.

### Locating Multiple Features of Nearly the Same Size

When repetitive features on an object are nearly the same size, they can be dimensioned with an identification letter, such as Y. In Figure 10.65, there are two sets of holes that

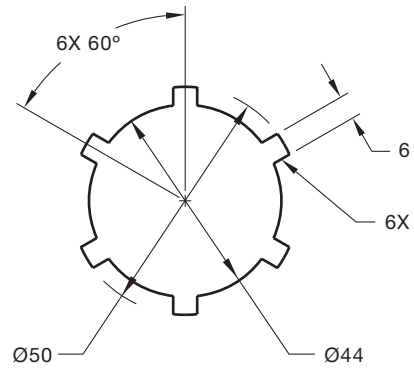


FIGURE 10.64 Locating multiple tabs.

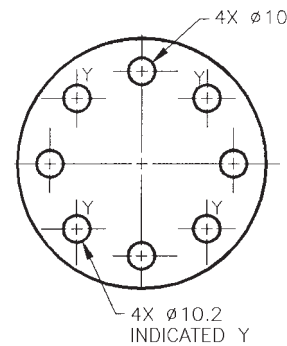


FIGURE 10.65 Dimensioning similar sized multiple features.

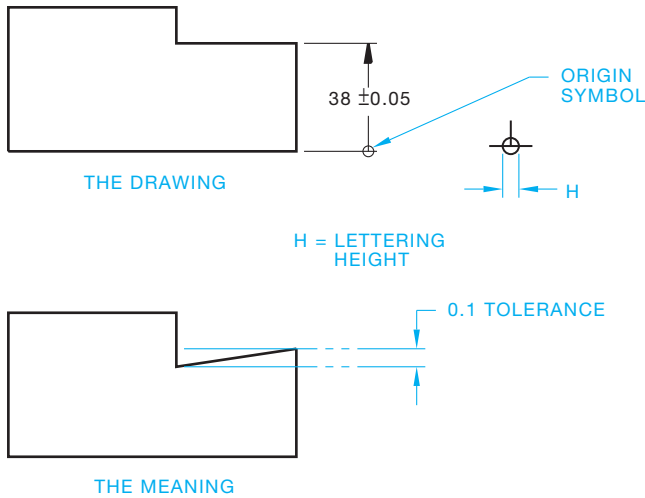
are close to the same diameter. It is impossible to distinguish the holes apart without individual identification. In this example, the 4X Ø 10.2 holes are identified with the letter Y by each hole, and the note: INDICATED Y is placed below the hole note.

### SPECIFYING DIMENSION ORIGIN

The **dimension origin** symbol is used when the dimension between two features must clearly identify from which feature the dimension originates. This method of dimensioning means the origin feature must be established first, and the related feature is then dimensioned from the origin (see Figure 10.66).

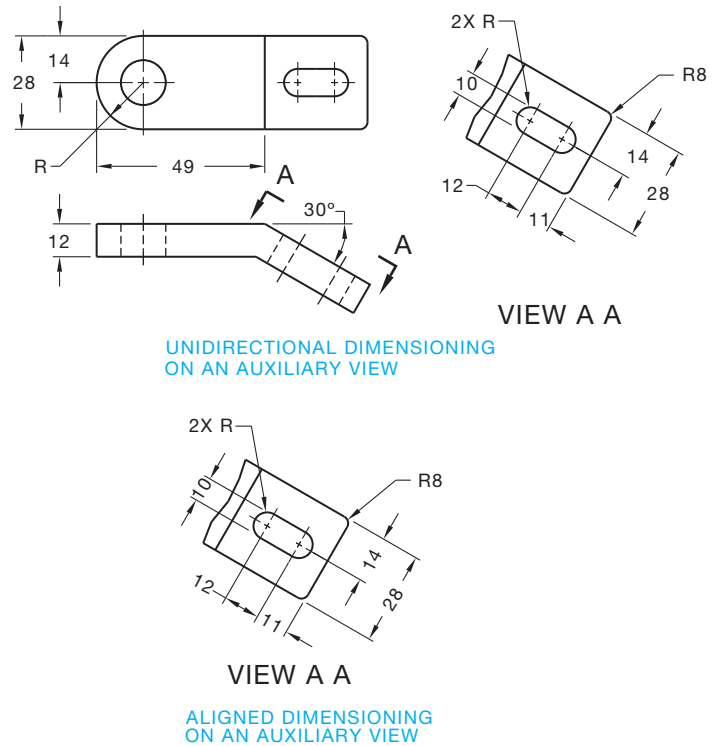
### DIMENSIONING AUXILIARY VIEWS

Dimensions should be placed on views that provide the best size and shape description of an object. In many instances, the surfaces of a part are foreshortened and require auxiliary views to describe true size, shape, and the location of features completely. Dimensions should be placed on the auxiliary view for clarity when foreshortened views occur. In unidirectional dimensioning, the dimension numerals are placed horizontally



**FIGURE 10.66** Using the dimension origin and the dimension origin symbol.

so they read from the bottom of the sheet. When aligned dimensioning is used, the dimension numerals are placed in alignment with the dimension lines (see Figure 10.67). Keep in mind that unidirectional dimensioning is the preferred ASME standard for numeral placement.



**FIGURE 10.67** Dimensioning auxiliary views. © Cengage Learning 2012

### DIMENSIONING WITH CADD

The proper placement and use of dimensions requires thought and planning. You must first determine the type of dimension that suits the application and then place the dimension on the drawing correctly. Most CADD systems offer a variety of dimensioning tools and options to assist dimensioning. Methods for placing dimensions vary, depending on the CADD software and design process. A basic approach is to use a dimensioning tool that allows you to dimension to points or a selected object. The common method is to choose the appropriate dimensioning command, select points or the object to dimension, and then locate the dimension value. Some CADD programs include tools that significantly automate dimensioning and may even allow you to dimension a view or drawing using a single operation.

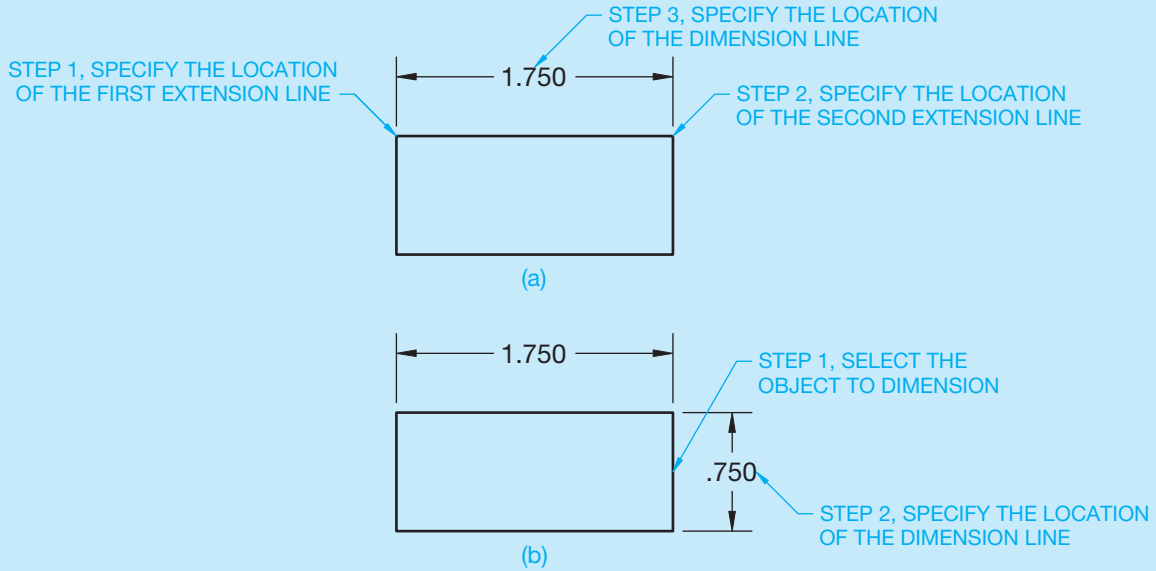
Figure 10.68a shows an example of the steps for drawing a horizontal linear dimension to establish the length of a feature. This example establishes the origin of extension lines according to point coordinates. Figure 10.68b shows an example of the steps for adding a vertical linear dimension to establish the height of a feature. This

example shows the alternative method of establishing the origin of extension lines by selecting an object. Depending on the software, you may use a general-purpose dimensioning command or a command specific to the type of dimension, such as the AutoCAD DIMLINEAR command for linear dimensions.

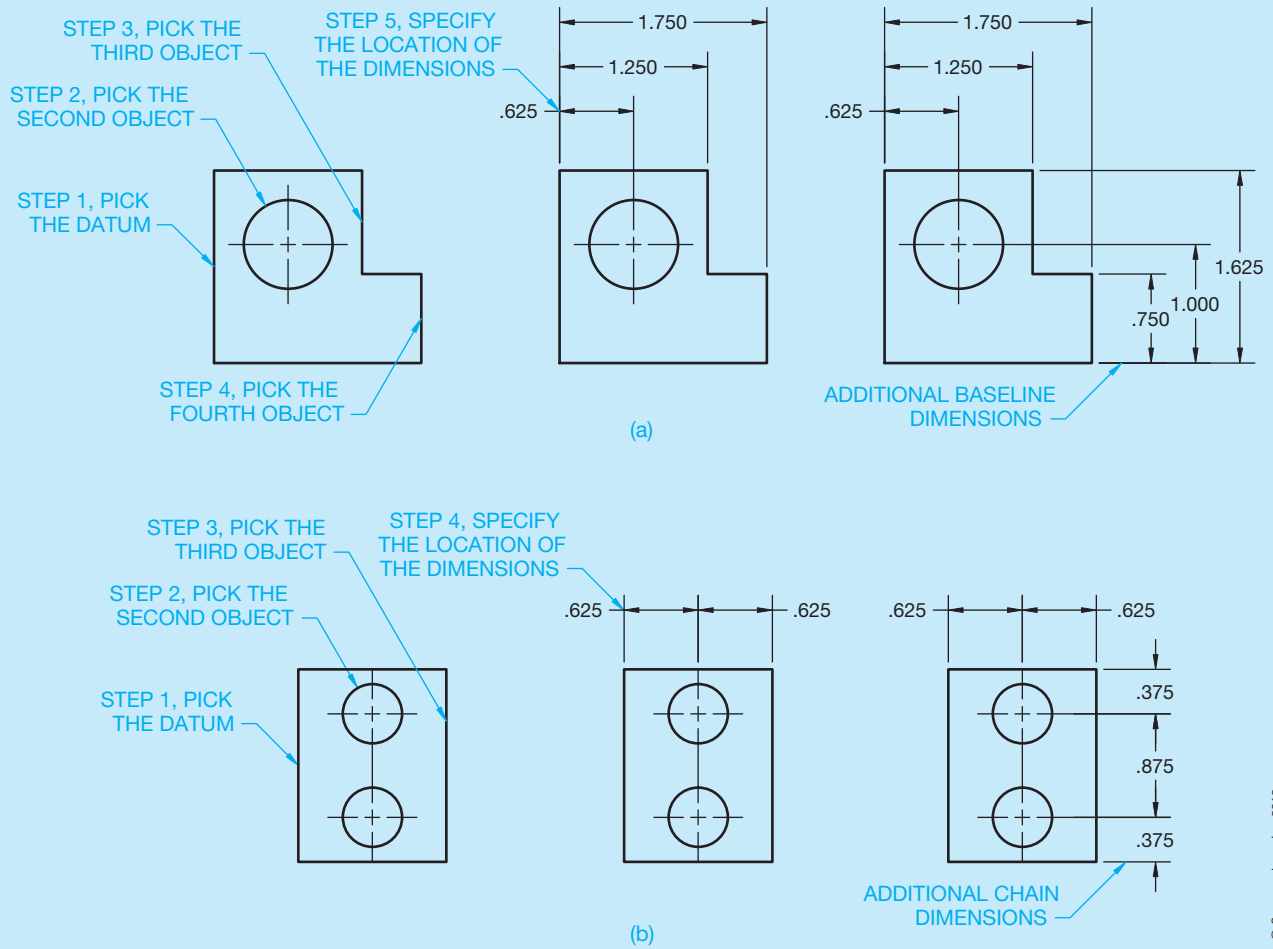
A basic example of automated dimensioning with CADD is using a baseline or chain dimensioning command. A baseline dimensioning command allows you to select several points or objects to define a series of baseline dimensions (see Figure 10.69a). The software typically spaces all dimension lines according to predefined distances, though you may have the option to specify the location for the first dimension line or adjust the spaces later. A chain dimensioning command allows you to select several points or objects to define a series of chain dimensions (see Figure 10.69b). Other programs allow you to create an entire group of dimensions at the same time, as shown in Figure 10.69. Other systems require you to establish the first dimension or specify the datum before placing additional dimensions using a baseline or chain dimensioning command.

(Continued)



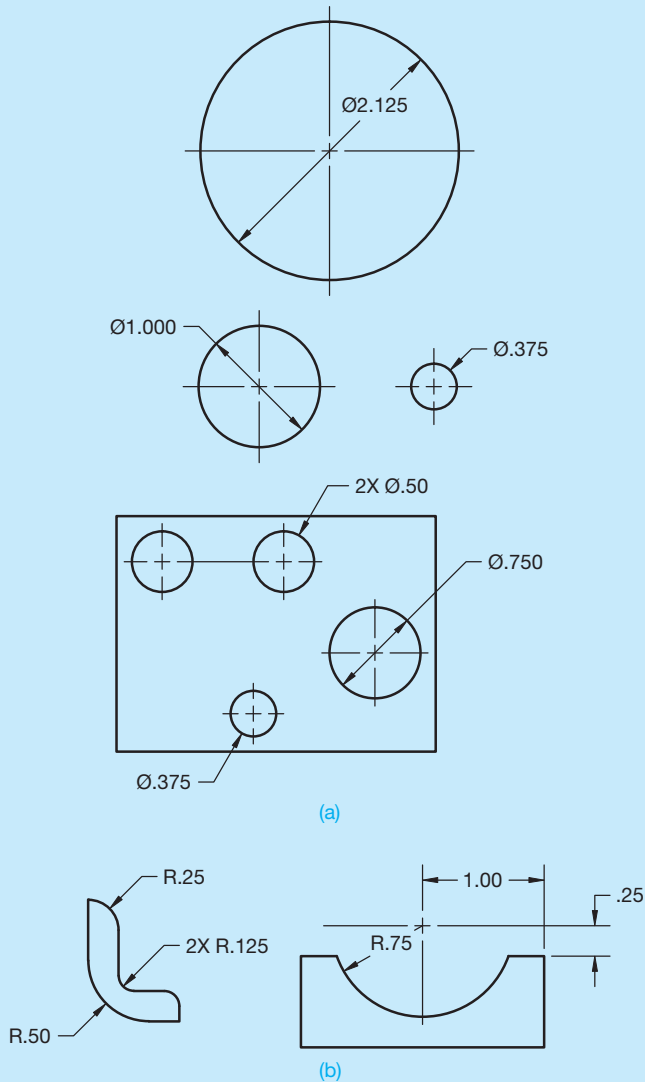


**FIGURE 10.68** Using CADD to place linear dimensions. (a) Specifying points to locate extension lines. (b) Selecting an object to locate extension lines. Dimension values in this figure are in inches.



**FIGURE 10.69** (a) Creating two sets of baseline dimensions using a baseline dimensioning command. (b) Creating two sets of chain dimensions using a chain dimensioning command. Dimension values in this figure are in inches.

(Continued)



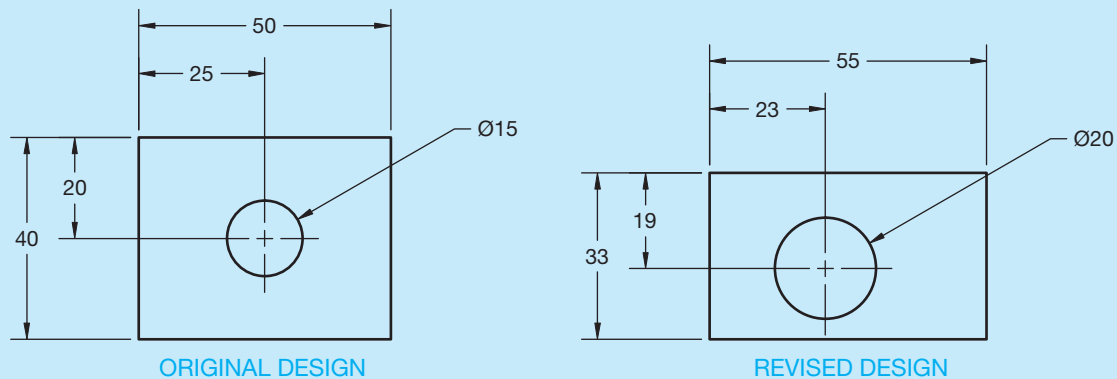
**FIGURE 10.70** Dimensioning circles and arcs with CADD. Dimension values in this figure are in inches. © Cengage Learning 2012

Some software provides a general-purpose dimensioning command that allows you to dimension different features, such as circles, arcs, and chamfers. The program automatically recognizes the object you select and attempts to place the appropriate dimension. Usually an icon or other on-screen information indicates the dimension that will form. Other software uses specific commands to dimension specific features, such as the AutoCAD DIMDIAMETER command for dimensioning circles and the DIMRADIUS command for dimensioning arcs. Typically, when dimensioning features such as circles and arcs, you select objects instead of points. Figure 10.70a shows examples of dimensioning circles with CADD. Figure 10.70b shows examples of dimensioning arcs with CADD.

### ASSOCIATIVE DIMENSIONING AND DIMENSIONAL CONSTRAINTS

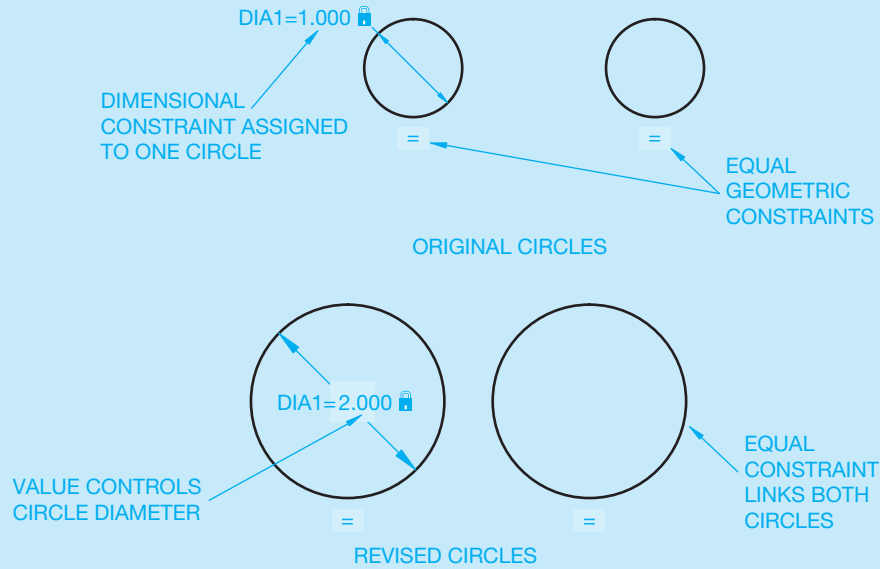
A CADD dimension is usually a single object or a group of objects that act as a single item. The dimension object includes all elements and characteristics assigned by the dimension style or standard. Usually, the distance between extension lines or the size and location of the selected object determines the dimension value, which the computer calculates. For example, if you draw a 25 mm-long line and then dimension the line, the dimension value displays 25. You typically have the option to add information to the value, such as a prefix or suffix, but for most applications, you do not change the calculated dimension value.

An **associative dimension** is associated with an object. The dimension value updates automatically when the object changes. For example, when you dimension the Ø15 circle in Figure 10.71 and then change the size of the circle to Ø20, the diameter dimension adapts to



**FIGURE 10.71** An example of revising a drawing with associative dimensions. Dimensions adjust to the modified geometry, and the dimension values update to reflect the size and location of the modified geometry. Dimension values in this figure are in inches.

(Continued)



**FIGURE 10.72** An example of a basic relationship created using dimensional and geometric constraints. Dimension values in this figure are in inches.

© Cengage Learning 2012

show the correct size of the modified circle. Associative dimensions relate best to object size and often make revisions easier. A **nonassociative dimension** is linked to point locations, not an object, and it does not update when the object changes. A nonassociative dimension is still a single object that updates when you make changes to the dimension, such as stretching the extension line origin. Nonassociative dimensions are appropriate when associative dimensions would result in dimensioning difficulty or unacceptable standards. When using nonassociative dimensions, remember to edit the dimension with the object it dimensions or adjust the dimension after the object changes.

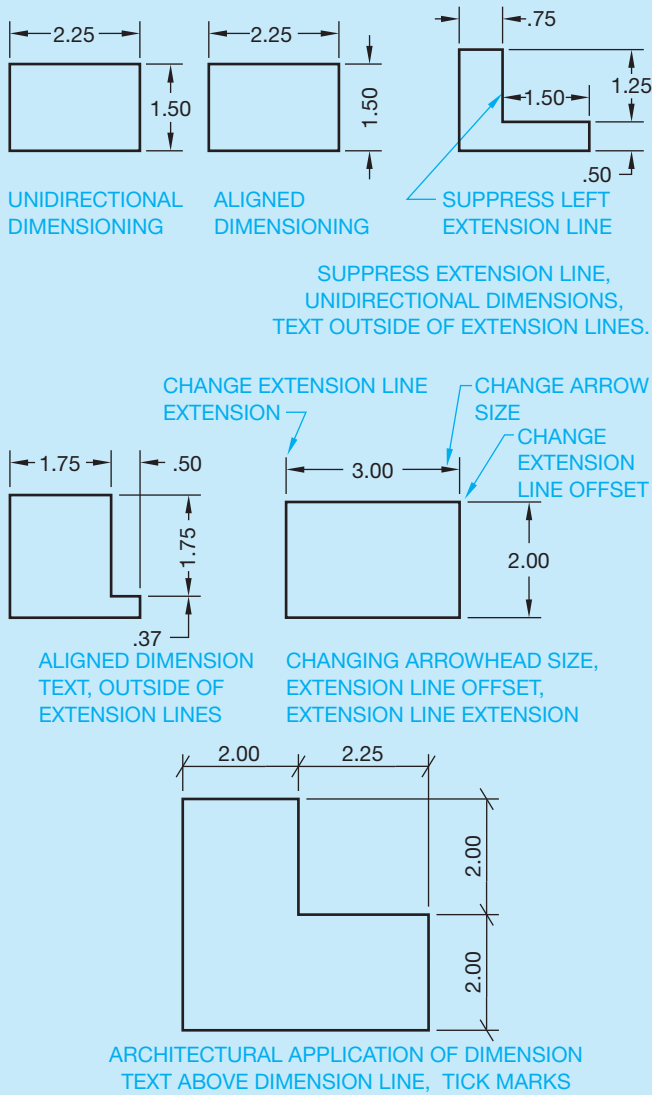
Dimension commands allow you to dimension a drawing, but unlike **constraints**, dimensions do not control object size and location. Constraints are geometric characteristics and dimensions that control the size, shape, and position of drawing geometry. **Geometric constraints** are geometric characteristics applied to restrict the size or location of geometry. **Dimensional constraints** are measurements that numerically control the size or location of geometry. Well-defined constraints allow you to incorporate and preserve specific design intentions and increase revision efficiency. For example, if two holes through a part, drawn as circles, must always be the same size, use a geometric constraint to make the circles equal and add a dimensional constraint to size one of the circles. The size of both circles changes when you modify the dimensional constraint value (see Figure 10.72).

## DIMENSION STYLES AND SETTINGS

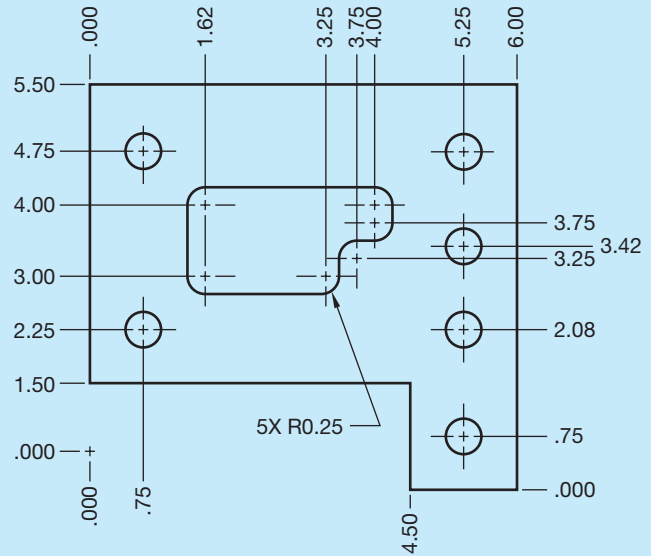
A **dimension style** presets many dimension characteristics to control the appearance of dimension elements. Dimension style settings usually apply to a specific drafting field or dimensioning application and correspond to appropriate drafting standards. For example, a mechanical drafting dimension style developed according to ASME Y14.5 uses unidirectional placement; references a text style assigned as RomanS, Arial, or CenturyGothic font; centers text in a break in the dimension line; and terminates dimension lines with arrowheads. An architectural drafting dimension style may use an aligned dimension format, reference a text style assigned a SansSerif or Stylus BT font, place text above the dimension line, and terminate dimension lines with tick marks. Dimensioning for drafting applications such as structural, industrial pipe, and civil drafting are discussed where they apply in this textbook. Figure 10.73 shows some of the flexibility available with adjusting dimension style.

You should generally create a dimension style for each unique but frequently used dimension appearance or function. For example, create a dimension style for unspecified tolerances and a different dimensions style with a common specified tolerance. Another example is developing a dimension style specifically for rectangular coordinate dimension without dimension lines (see Figure 10.74). Add dimension styles to drawing

(Continued)



**FIGURE 10.73** Examples of using dimension styles to display dimensions for specific applications. © Cengage Learning 2012



**FIGURE 10.74** Rectangular coordinate dimensioning without dimension lines developed using a specific dimension style and dimensioning command. Dimension values in this figure are in inches. Courtesy CADMASTER, Inc.

templates for repeated use. Most CADD systems provide ease and flexibility to control the appearance of dimensions for unique dimensioning requirements without using a separate dimensions style. For example, change the precision of, or add a prefix to, a limited number of special-case dimensions instead of creating separate dimension styles. It is good practice to define dimension styles before you place dimensions as you draw so that dimensions display correctly. However, most CADD systems allow you to modify dimension style variables at any time and update existing dimensions according to new display characteristics.

## USING GENERAL NOTES

### STANDARDS

**ASME** According to ASME Y14.5-2009, notes are placed on the drawing using uppercase text and the notes read from the bottom of the sheet. General notes are located next to the title block for ASME drawings. The exact location of the general notes depends on specific company or school standards. A common location for general notes is the lower-left corner of the drawing, usually .5 in. 912 mm each way from the border line. Military standards specify general notes be located in the upper-left corner of the drawing.

ASME Y14.1, *Decimal Inch Drawing Sheet Size and Format*, and ASME Y14.1M, *Metric Drawing Sheet Size and Format*, provide recommended layout for inch and metric drawing sheets and title blocks. This is described in detail in Chapter 2 of this textbook.

The notes previously described throughout this chapter are classified as **specific notes** because they refer to specific features of an object. Specific notes are also referred to as local notes. General notes relate to the entire drawing. Each drawing contains a certain number of general notes either in or near


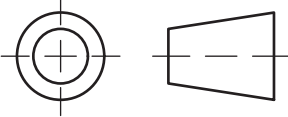
UNLESS OTHERWISE SPECIFIED DIMENSIONS ARE IN INCHES (IN) TOLERANCES: .X ± .1 .XX ± .01 .XXX ± .005 .XXXX ± .0050 ANGULAR: ± 30'		APPROVALS		DATE		<b>WRIGHT MEDICAL TECHNOLOGY PROPRIETARY:</b> THIS MATERIAL IS CONSIDERED PROPRIETARY AND MUST NOT BE COPIED OR EXHIBITED EXCEPT WITH PERMISSION OF WRIGHT MEDICAL TECHNOLOGY'S RESEARCH & DEVELOPMENT DEPARTMENT AND MUST BE DESTROYED AFTER USE.   5677 Airline Road Arlington, TN 38002	
		DRAWN	DPM				
THIRD ANGLE PROJECTION		CHECKED	DAM			TITLE <b>INST SAW GDE TOP CAP</b>	
		APPROVED	DAS				
		MATERIAL ASTM A564 TYPE 630		SIZE	CAGE CODE	DWG NO.	REV
		FINISH GLASS BEAD		B		102450	0
		DO NOT SCALE DRAWING		SCALE	2:1	SHEET 1 OF 1	

FIGURE 10.75 Typical title block information. Courtesy Wright Medical Technology, Inc.

the drawing title block. The types of general notes found in the title block can include a variety of information as shown in Figure 10.75. ASME Y14.1, *Decimal Inch Drawing Sheet Size and Format*, and ASME Y14.1M, *Metric Drawing Sheet Size and Format*, recommend that general notes in the title block can provide the following:

- Material specifications.
- Dimensions: inches or millimeters.
- General tolerances.
- Confidential note, copyrights, or patents.
- Name of drafter or drawing creator.
- Scale.
- Date.
- Part name.
- Drawing size.
- Part number.
- Number of revisions.
- First-angle or third-angle projection symbol.
- ANSI, ASME, MIL (military), or other standard reference.
- General machining, finish, or paint specifications.
- Identification of features that are the same throughout the drawing.

The general notes placed outside the title block are generally identified with the word NOTES typically lettered with text .24 in. (6 mm) high and are placed below in numerical order using text .12 in. (3 mm) high. The space between notes is from one-half to full height of the lettering. Figure 10.76 shows general notes commonly included on ASME standard format drawings. Other common locations for general notes are directly above the title block, just to the left of the title block, or in the upper-left corner of the drawing. Depending on company or school standards, the first note typically reads DIMENSIONING AND TOLERANCEING PER ASME Y14.5-2009. This note should be included on all new drawings.

NOTES:

1. INTERPRET DRAWING IAW MIL-STD-100. CLASSIFICATION PER MIL-T-31000, PARA 3.6.4.
2. DIMENSIONS AND TOLERANCES PER ASME Y14.5-2009.
3. PART TO BE FREE OF BURRS AND SHARP EDGES.
4. BAG ITEM AND IDENTIFY IAW MIL-STD-130, INCLUDE CURRENT REV LEVEL: 64869-0956356 REV 42375.
5. DIMENSION APPLIES BEFORE PLATING.

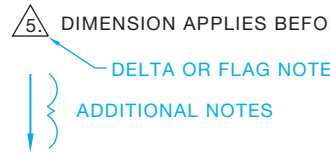


FIGURE 10.76 General notes located in the lower-left corner of the sheet. Notes can be conveniently place to read from the first note downward with CADD. This makes it easy to continue from one note to the next. Editing notes is easy with CADD because all you have to do is move the group of notes up to place addition notes when needed. Notice the flag note using the delta symbol (Δ) for note number 5.

Additional notes depend on the information required to support the drawing.

General notes placed outside the title block can include some of the information previously listed for inside the title block. This depends on company or school standards. General notes placed outside the title block commonly contain this type of information:

- A reference to the standard or standards used on the drawing. Some companies list a variety of applicable standards.
- Machining practices used on the entire part, such as removal of all burrs and sharp edges. A burr is a rough edge left by a cutting tool or other operation.
- Dimensions common throughout the drawing, such as all fillets and rounds of the same radius.
- Other specifications related to the entire drawing, such as common surface finish, painting, or other treatments.

The dimension, machining practice, or other specifications relating to specific features are shown on the drawing with dimensioning practices and using specific notes as discussed throughout this chapter.

**Specifications** are any written information or instructions included on the drawing or with a set of drawings, giving all necessary information not shown in the drawing field. In addition to the previous discussion, specifications include such items as quality requirements; manufacturer name, type, part number, and details for purchase parts or material applications and finishes; and instructions defining the manner in which work is to be done. Specifications are commonly included with the general notes when possible. These specifications often refer to an industry standard application, such as ASME, ANSI, American Welding Society (AWS), Aerospace Industries Association of America (AIAA), American Institute of Steel Construction (AISC), Society of Automotive Engineers (SAE), American Petroleum Institute (API), Military Standards (MIL-STD), and many others. Reference can be made to details found in these and other nationally and internationally accepted standards by code or content because their meaning is clear and consistent in the industry. Examples of these types of specifications are similar to the following general notes found on drawings:

- DRAFT REQUIREMENTS PER AIAA STANDARDS E4, E7, AND E8, UNLESS OTHERWISE SPECIFIED.
- HEAT MANIFOLD ITEM 11 TO 200 °F
- CHILL UPPER BEARING ITEM 21 TO -50 °F
- HEAT TREAT PER MIL-H-6875 TO H1100 CONDITION.
- PENETRATE INSPECT FINISHED PART PER MIL-STD-271, GROUP III.

The words UNLESS OTHERWISE SPECIFIED are often placed with notes to remind the reader that the given specification generally applies, but they can be modified by other information provided on the drawing or in other documents.

Additional specifications can be provided off the drawing in related documents. These types of specifications can be prepared using upper- and lowercase text as in a typical text document. However, lowercase text is not recommended on formal drawings.

## Using Flag Notes

A **flag note**, sometimes referred to as a **delta note**, is a specific note placed with general notes and keyed to the drawing with a delta symbol ( $\Delta$ ). The term **delta** refers to a triangle symbol placed on the drawing for reference. The triangle is commonly placed next to a dimension such as 2.625  $\Delta$  or other location where it applies to a feature or item. This is used to refer the reader to a general note that relates to this item. This method is often used when it applies to a specific feature, but placing the note directly on the drawing is difficult because the note is too long or it applies to several dimensions or features. Look at the note  $\Delta$  in Figure 10.76. This note relates to the same delta item located somewhere on the drawing. Some companies use symbols other than a triangle. Hexagons and circles also can be used, but the triangle is common.

## TOLERANCING APPLICATIONS

A review of the following tolerancing definitions is suggested to help you gain a good understanding of the terminology associated with dimensioning practices. A tolerance is the total permissible variation in a size or location dimension. Dimensions are placed on a drawing to make sure the parts fit together in an assembly and that all parts function as intended in that assembly. The following describes the related tolerance terminology and the variety of fits used for different applications.

A specified dimension is that part of the dimension from which the limits are calculated. For example, 15.8 is the specified dimension of  $15.8 \pm 0.2$ .

**Plus-minus dimensioning** uses a bilateral or unilateral tolerance format, depending on the application. Plus-minus dimension values are placed using the plus-minus symbol ( $\pm$ )—for example,  $12 \pm 0.1$  or  $.750 \pm .005$ . A bilateral tolerance is allowed to vary in two directions from the specified dimension, as in  $6.5^{+0.1}_{-0.3}$  or  $6.5 \pm 0.2$ .

The dimension value  $6.5^{+0.1}_{-0.3}$  is an unequal bilateral tolerance, and the  $6.5 \pm 0.2$  dimension value is called an equal bilateral tolerance.



**NOTE:** Bilateral tolerancing is the most common tolerancing method. Manufacturers typically prefer equal bilateral tolerancing because they attempt to manufacture features as close to the specified dimension as possible.

A unilateral tolerance varies in only one direction from the specified dimension. For example,  $22^{0}_{-0.2}$  or  $19.5^{+0.5}_{0}$ .



**NOTE:** Some companies use unilateral tolerances to define fits between mating parts. An example might be a slip fit or press fit where one part is dimensioned  $\varnothing.250^{+0.002}_{-0.000}$ , and the mating part is dimensioned  $\varnothing.248^{+0.000}_{-0.002}$ , which is a slip fit or sliding fit. However, manufacturers who use the drawing to program computerized numerically controlled (CNC) machining equipment often avoid unilateral tolerancing because the program is generated from the 3-D CAD model and the CAD model should be created at the mean value so the machinist has tolerance to apply in both directions. If the CAD model is created at one of the extremes and a unilateral tolerance is given, then the machinist must compensate for the tolerance difference and program the machine to the mean value. This might require the machinist to re-create or modify the model to create the CNC program.

**Limit dimensioning** is an alternative method of showing and calculating tolerance. With limit dimensioning, the extreme values of the tolerance are given in the dimension. The limits are the upper limit and the lower limit. The **upper limit** is the largest the feature can be within the given tolerance of the dimension. The **lower limit** is the smallest the feature can

be within the given tolerance of the dimension. The following gives example dimensions and the calculations used to determine the upper and lower limits of the tolerance.


*Example 1:*  $19.0 \pm 0.1$   
 Upper limit:  $19.0 + 0.1 = 19.1$   
 Lower limit:  $19.0 - 0.1 = 18.9$

*Example 2:*  $9.5 - \begin{smallmatrix} 0 \\ 0.5 \end{smallmatrix}$   
 Upper limit:  $9.5 + 0 = 9.5$   
 Lower limit:  $9.5 - 0.5 = 9.0$

The tolerance, being the total permissible variation in the dimension, is calculated by subtracting the lower limit from the upper limit as demonstrated in these examples.

*Example 3:*  $22.0 \pm 0.1$   
 Upper limit: 22.1  
 Lower limit:  $-21.9$   
 Tolerance: 0.2

*Example 4:*  $31.75 + \begin{smallmatrix} 0.10 \\ 0 \end{smallmatrix}$   
 Upper limit: 31.85  
 Lower limit:  $-31.75$   
 Tolerance: 0.10

 **NOTE:** Limit dimensioning is most common for defining fits between mating parts, such as a sliding fit between a hole and shaft or a press fit between a hole and bearing, because it makes it easy at a glance to see the clearance or interference between the mating parts.

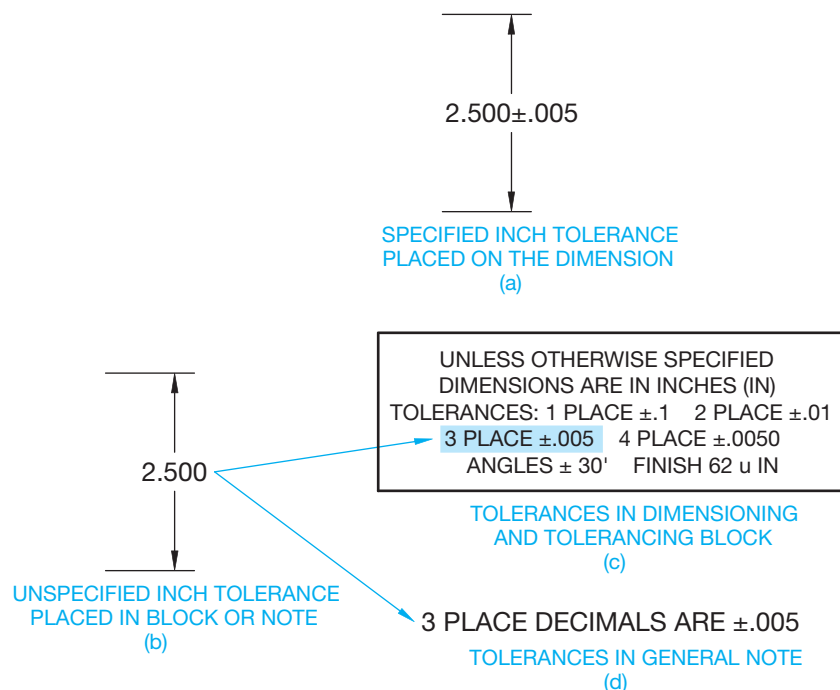
Some companies, or departments within a company, such as an inspection department, prefer limit dimensioning, because it does not require calculating limits as does plus and minus tolerancing. However, the actual dimension of the object in the drawing is unknown. When a limit dimension is used, there is no way for the reader of the drawing to know the actual value used to create the CAD model. This might be important if the model needs to be re-created from the drawing later. If specific dimensions are used, then they match the actual value of the model.

## Single Limits

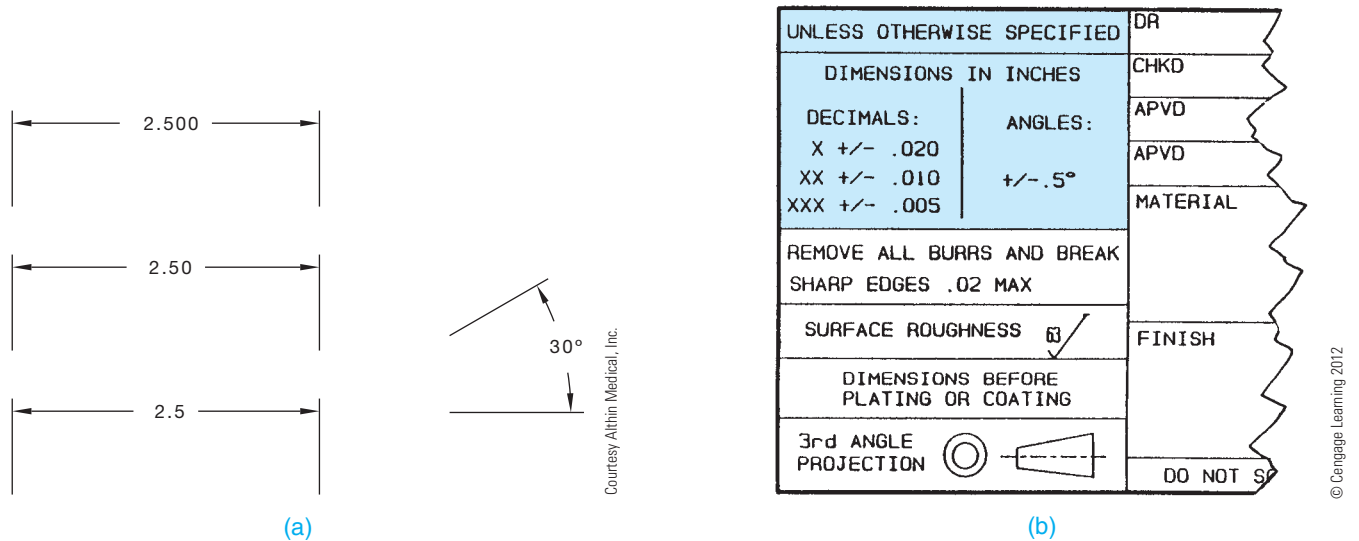
Various features, such as chamfers, fillets, rounds, hole depths, and thread lengths, can be dimensioned with single limits. Single limits are used when the specified dimension cannot be any more than the maximum or less than the minimum given value. The abbreviation for minimum (MIN) or maximum (MAX) follows the dimension value to specify a single limit application. The unspecified limit is determined by the design, or it can be 0 when MAX is used or reach infinity when MIN is specified.

## Specified and Unspecified Inch Tolerances

All dimensions on a drawing have a tolerance except reference, maximum, minimum, or stock size dimensions. The tolerance can be applied directly to the dimension, identified in the dimensioning and tolerancing block or indicated by a general note. A tolerance applied directly to a dimension is called a **specified tolerance** as shown in Figure 10.77a. A



**FIGURE 10.77** Inch tolerance applications. (a) A specified inch tolerance with the tolerance value placed on the dimension. (b) An unspecified inch tolerance with the tolerance value placed in the dimensioning and tolerancing block or a general note. (c) The unspecified tolerance values placed in the dimensioning and tolerancing block. (d) A typical general note for three place unspecified tolerance values.



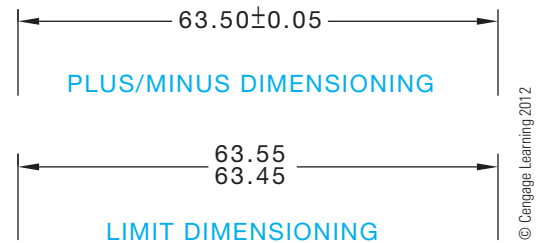
**FIGURE 10.78** (a) General tolerances found in a typical company dimensioning and tolerancing block, group next to the title block. Dimension values in this figure are in inches. (b) Typical drawing dimensions showing three place, two place, and one place unspecified tolerance dimensions. Dimension values in this figure are in inches.

dimension can read without a specified tolerance as shown in Figure 10.77b. Dimensions without a specified tolerance have what is referred to as **unspecified tolerances** and relate to **general tolerances**.

All dimensions have tolerances, so general tolerances are specified in the dimensioning and tolerancing block or a general note. Figure 10.77c shows a dimensioning and tolerancing block, which is typically found near or as an element of the title block. The dimensioning and tolerancing block lists the general tolerance for one-place dimensions in inches such as  $2.5 \pm .1$ , two-place dimensions such as  $2.50 \pm .01$ , three-place dimensions such as  $2.500 \pm .005$ , and four-place dimensions such as  $2.5000 \pm .0050$ . The tolerance for unspecified angular dimensions is  $\pm 30'$ . Figure 10.77d shows general tolerances specified in a general note.

General tolerance specifications can also be given in the dimensioning and tolerancing block using x to represent the number of decimal places. The partial industry title block with a dimension and tolerancing block shown in Figure 10.78a uses x to refer to the tolerance applied to one-place decimal dimensions, xx to refer to the tolerance applied to two-place decimals, and xxx to refer to the tolerance applied to three-place decimal dimensions. Using this dimensioning and tolerancing block as an example, the tolerances of the dimensions in Figure 10.78b are as follows (given in inches):

- 2.500 has .xxx  $\pm .005$  applied;  $2.500 \pm .005$ , tolerance equals .010.
- 2.50 has .xx  $\pm .010$  applied;  $2.50 \pm .010$ , tolerance equals .020.
- 2.5 has .x  $\pm .020$  applied;  $2.5 \pm .020$ , tolerance equals .040.
- $30^\circ$  has Angles  $\pm 0.5^\circ$  applied;  $30^\circ \pm 0.5^\circ$ , tolerance equals  $1^\circ$ .



**FIGURE 10.79** Specific tolerance dimensions using plus/minus dimensioning and limit dimensioning.

As a review, dimensions requiring tolerances different from the general tolerances given in the dimensioning and tolerancing block or a general note must be specified on the dimension in the drawing. These are referred to as **specific tolerance dimensions** and are represented with plus/minus dimensioning or limits dimensioning as shown in Figure 10.79.

### Specified and Unspecified Metric Tolerances

The previous discussion using general tolerances applied in a general note or in the title block only applies to inch dimensioning. This does not apply to metric dimensioning because trailing zeros are not included in metric dimensions. Metric tolerancing is generally controlled by the ISO 2768 standard, *General Tolerances*, developed by ISO. ISO 2768 tolerancing is based on the size of features. Small feature sizes have closer tolerances, and larger feature sizes have larger tolerances. There are four classes of size tolerances: fine (f), medium (m), coarse (c), and very coarse (v). Each class is represented by its abbreviation in parentheses.

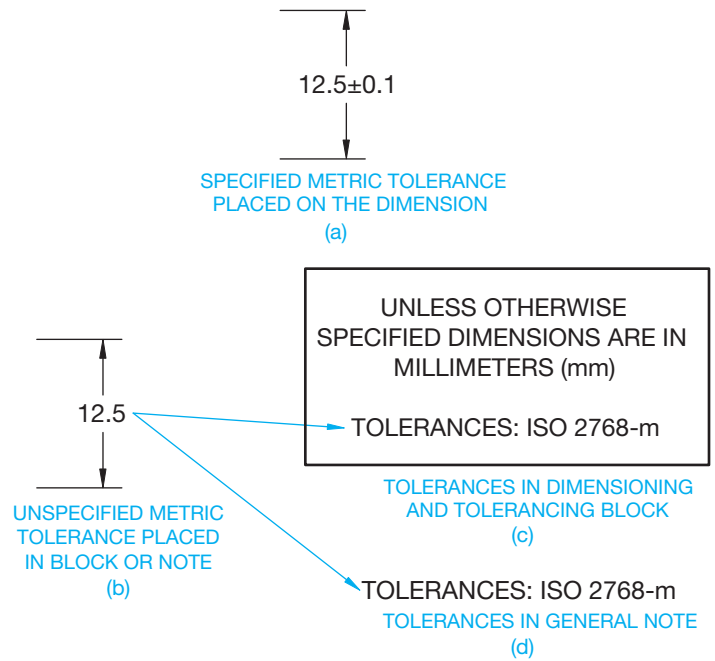


A company can select the class that best meets its dimensioning requirements. For example, a company that manufactures precision parts and equipment might select the medium class (m) for general metric tolerances. Figure 10.80a shows an example of a specified metric dimension. Figure 10.80b shows an unspecified metric dimension. General tolerances according to ISO 2768 are specified in the dimensioning and tolerancing block, as shown in Figure 10.80c, or a general note, as shown in Figure 10.80d.

Table 10.1 gives the ISO 2768 general tolerances for linear, radius, chamfer, and angular dimensions. Notice in Table 10.1 that sizes from 0 mm to 0.5 mm are not included. Dimensions under 0.5 mm must have the specified tolerance on the dimension on the drawing. Any dimension that requires a different tolerance from the general tolerances listed in Table 10.1 must have the specific tolerance directly applied to the dimension on the drawing.

### Applying Statistical Tolerancing

**Statistical tolerancing** is the assigning of tolerances to related dimensions in an assembly based on the requirements of statistical process control (SPC). SPC is discussed in Chapters 4 and 13. Statistical tolerancing is displayed in dimensioning as shown in Figure 10.81a. When the feature can be manufactured using SPC or conventional means, it is necessary to show both the statistical tolerance and the conventional tolerance as in Figure 10.81b. The appropriate general note should also accompany the drawing as shown in Figure 10.81.



**FIGURE 10.80** Metric tolerance applications. (a) A specified metric tolerance with the tolerance value placed on the dimension. (b) An unspecified metric tolerance with the tolerancing according to ISO 2768 as specified in the dimensioning and tolerancing block or a general note. (c) ISO 2768 tolerancing specified in the dimensioning and tolerancing block. (d) ISO 2768 tolerancing specified in a general note. © Cengage Learning 2012

**TABLE 10.1 GENERAL TOLERANCES FOR METRIC DIMENSIONS USING ISO 2768 GENERAL TOLERANCE STANDARD.**

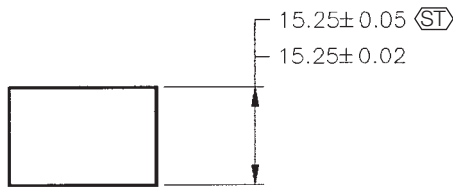
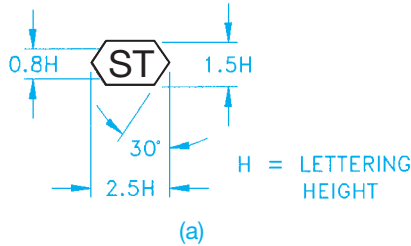
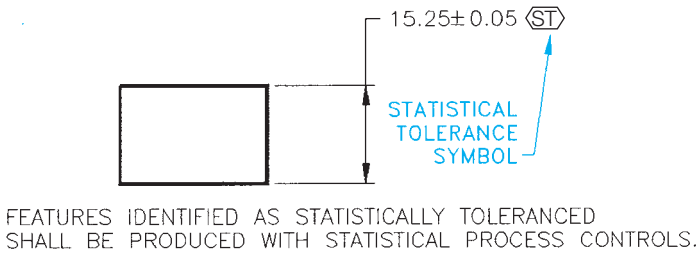
Permissible Tolerances for Linear Dimensions (mm)								
	0.5–3	3–6	6–30	30–120	120–400	400–1000	1000–2000	2000–4000
Fine (f)	±0.05	±0.05	±0.1	±0.15	±0.2	±0.3	±0.5	
Medium (m)	±0.1	±0.1	±0.2	±0.3	±0.5	±0.8	±1.2	±2
Coarse (c)	±0.2	±0.3	±0.5	±0.8	±1.2	±2	±3	±4
Very coarse (v)		±0.5	±1	±1.5	±2.5	±4	±6	±8

Permissible Tolerances for External Radii and Chamfer Dimensions (mm)			
	0.5–3	3–6	over 6
Fine (f)	±0.2	±0.5	±1
Medium (m)	±0.2	±0.5	±1
Coarse (c)	±0.4	±1	±2
Very coarse (v)	±0.4	±1	±2

Permissible Tolerances for Ranges of Shorter Side Lengths of the Angle (mm)					
	Up to 10	10–50	50–120	120–400	over 400
Fine (f)	±1°	±0°30'	±0°20'	±0°10'	±0°5'
Medium (m)	±1°	±0°30'	±0°20'	±0°10'	±0°5'
Coarse (c)	±1°30'	±1°	±0°30'	±0°15'	±0°10'
Very coarse (v)	±3°	±1°	±1	±0°30'	±0°20'

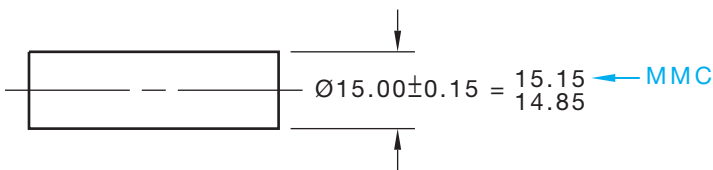


**FIGURE 10.81** Statistical tolerancing application and notes, and the statistical tolerancing symbol. © Cengage Learning 2012

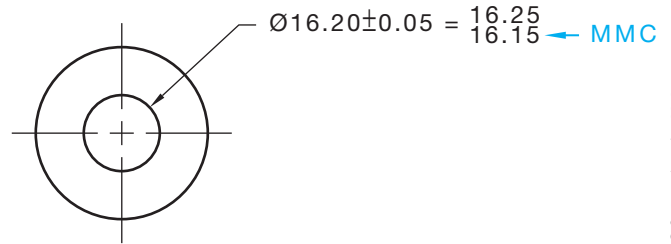
### Maximum and Least Material Conditions

Maximum material condition (MMC) is the condition of a part or feature when it contains the most amount of material within the stated limits. The key is *most material*. The MMC of an external feature is the upper limit (see Figure 10.82). The MMC of an internal feature is the lower limit (see Figure 10.83).

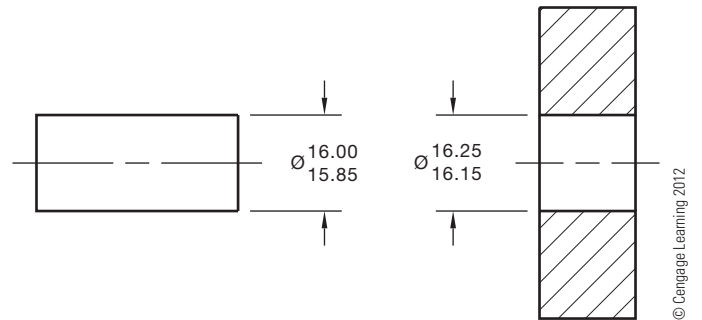
The least material condition (LMC) is the opposite of MMC. LMC is the least amount of material possible in the size of a feature within the stated limits. The LMC of an external feature is its lower limit. The LMC of an internal feature is its upper limit.



**FIGURE 10.82** Maximum material condition (MMC) of an external feature. Plus/minus dimension shown with the limits calculated. © Cengage Learning 2012



**FIGURE 10.83** Maximum material condition (MMC) of an internal feature. Plus/minus dimension shown with the limits calculated.



**FIGURE 10.84** A clearance fit between two mating parts. Limits dimensions shown.

### Clearance Fit

A **clearance fit** is a condition when, because of the limits of dimensions, there is always a clearance between mating parts. The features in Figure 10.84 have a clearance fit. Notice the largest limit of the shaft is smaller than the smallest hole limit, which allows for a clearance fit.

### Allowance

The allowance of a clearance fit between mating parts is the tightest possible fit between the parts. The allowance is calculated with the formula:

$$\frac{\text{MMC Internal Feature} - \text{MMC External Feature}}{\text{Allowance}}$$

The allowance of the parts in Figure 10.84 is:

MMC Internal Feature	16.15
-MMC External Feature	-16.00
Allowance	0.15

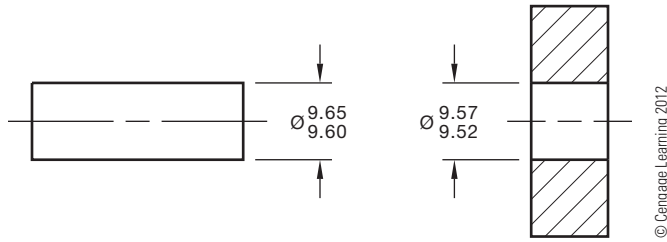
### Interference Fit

Interference fit also known as **force** or **shrink** fit is the condition that exists when, because of the limits of the dimensions, mating parts must be pressed together. Interference fits are used,

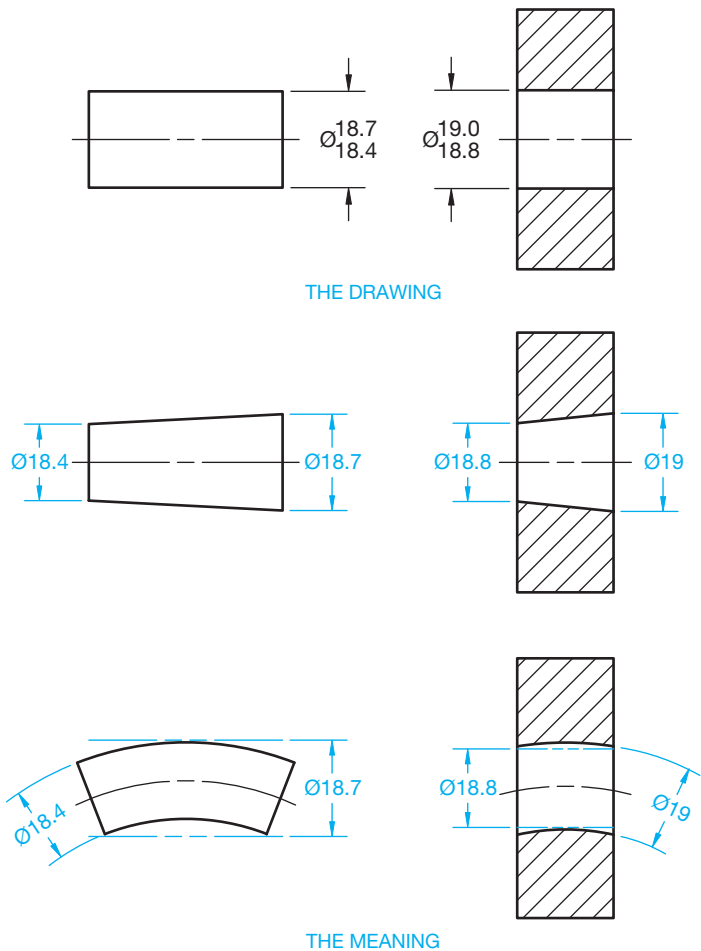
for example, when a bushing must be pressed onto a housing or when a pin is pressed into a hole (see Figure 10.85).

### Extreme Form Variation

The limits of size of a feature controls the amount of variation in size and geometric form. This is referred to as “Rule 1” in ASME Y14.5. The limits of size establishes the dimensional limits between MMC and LMC. The form of the feature can vary between the upper limit and lower limit of a size dimension. This is known as **extreme form variation**, as shown in Figure 10.86.



**FIGURE 10.85** An interference fit between two mating parts. Limits dimensions shown.



**FIGURE 10.86** Extreme form variation for external and internal clearance fit applications. © Cengage Learning 2012

The control of geometric form established by limits of size does not apply to premanufactured items, such as bar stock, sheets, tubing, or structural shapes. These items are produced to government or industry standards that have established geometric tolerances, such as straightness and flatness. These standards govern cases where the finished product contains the original premanufactured shape, unless other geometric tolerances are specified on the drawing.

### Types of Fits

Based on ANSI/ASME B4.1, *Preferred Limits and Fits for Cylindrical Parts*, the three general groups of limits and fits between mating parts are running and sliding fits, force fits, and locational fits. Based on ANSI/ASME B4.2, *Preferred Metric Limits and Fits*, the general groups of metric limits and fits between mating parts are clearance fits, transition fits, and interference fits. The variety of inch and metric limits and fits are described in the following.

### Selection of Fits

In selecting the limits of size for any application, the type of fit is determined first based on the use or service required from the equipment being designed, and then the limits of size of the mating parts are established to ensure the desired fit is produced. The number of standard fits described here covers most applications.

### Designation of Standard ANSI Fits

Standard fits are designated by means of the following symbols, which facilitate reference to classes of fit for educational purposes. The symbols are not intended to be shown on manufacturing drawings; instead, sizes should be specified on drawings. The letter symbols used are as follow:

- RC Running, or Sliding, Clearance Fit
- LC Locational Clearance Fit
- LT Transition Clearance, or Interference, Fit
- LN Locational Interference Fit
- FN Force, or Shrink, Fit

These letter symbols are used together with numbers representing the class of fit—for example, FN 4 represents a class 4 force fit.

### Description of Standard ANSI Fits

The classes of fits are arranged in three general groups known as **running and sliding fits**, locational fits, and force fits. Standard fit tables are given in Appendix I.

**Running and Sliding Fits (RFC)** Running and sliding fits are intended to provide a similar running performance with suitable lubrication allowance throughout their range of sizes. The clearances for the first two classes, used chiefly as sliding fits,

increase more slowly with the diameter than do the clearances for the other classes, so accurate location is maintained even at the expense of free relative motion. These fits are described as follows:

- RC1: **Close sliding fits** are intended for the accurate location of parts that must assemble without perceptible play.
- RC2: **Sliding fits** are intended for accurate location but with greater maximum clearance than class RC1. Parts made to this fit move and turn easily but are not intended to run freely, and in the larger sizes they may seize with small temperature changes.
- RC3: **Precision running fits** are about the closest fits that can be expected to run freely and are intended for precision work at slow speeds and light journal pressures. However, these are not suitable where appreciable temperature differences are likely to be encountered.
- RC4: **Close running fits** are intended chiefly for running fits on accurate machinery with moderate surface speeds and journal pressures, where accurate location and minimum play are desired.
- RC5 and RC6: **Medium running fits** are intended for high running speeds, or heavy journal pressures, or both.
- RC7: **Free running fits** are intended for use where accuracy is not essential, or where large temperature variations are likely to be encountered, or under both these conditions.
- RC8 and RC9: **Loose running fits** are intended for use where wide commercial tolerances may be necessary, together with an allowance, on the external member.

### Locational Fits (LC, LT, and LN)

**Locational fits** are fits intended to determine only the location of the mating parts. Locational fits provide rigid or accurate location, as with interference fits, or provide some freedom of location, as with clearance fits. Accordingly, locational fits are divided into three groups: clearance fits (LC), transition fits (LT), and interference fits (LN). These fits are described as follows:

- LC: **Locational clearance fits** are intended for parts that are normally stationary but can be freely assembled or disassembled. They range from snug fits for parts requiring accuracy of location, through medium clearance fits for parts such as spigots, to looser fastener fits where freedom of assembly is of prime importance.
- LT: **Locational transition fits** are a compromise between clearance and interference fits. They are for applications where accuracy of location is important but either a small amount of clearance or interference is permissible.
- LN: **Locational interference fits** are used where accuracy of location is of prime importance and for parts requiring rigidity and alignment with no special requirements for bore pressure. Such fits are not intended for parts designed

to transmit frictional loads from one part to another by virtue of the tightness of fit. Such conditions are covered by force fits.

### Force Fits (FN)

Force, or shrink, fits constitute a special type of interference fit normally characterized by maintenance of constant bore pressures throughout its range of sizes. The interference varies almost directly with diameter, and the difference between its minimum and maximum values is small to maintain the resulting pressures within reasonable limits. These fits are described as follows:

- FN1: **Light drive fits** are those requiring light assembly pressures and producing more or less permanent assemblies. They are suitable for thin sections or long fits or in external cast iron members.
- FN2: **Medium drive fits** are suitable for ordinary steel parts or for shrink fits on light sections. They are about the tightest fits that can be used with high-grade cast iron external members.
- FN3: **Heavy drive fits** are suitable for heavy steel parts or for shrink fits in medium sections.
- FN4 and FN5: Force fits are suitable for parts that can be highly stressed or for shrink fits where the heavy pressing forces required are impractical.

### Establishing Dimensions for Standard ANSI Fits

The fit used in a specific situation is determined by the operating requirements of the machine. When the type of fit has been established, the engineering drafter refers to tables that show the standard hole and shaft tolerances for the specified fit. One source of these tables is the *Machinery's Handbook*. Tolerances are based on the type of fit and nominal size ranges, such as 0 – .12, .12 – .24, .24 – .40, .40 – .71, .71 – 1.19, and 1.19 – 1.97 in. So, if you have a 1 in. nominal shaft diameter and an RC4 fit, refer to Figure 10.87 to determine the shaft and hole limits. The hole and shaft limits for a 1 in. nominal diameter are:

- Upper hole limit =  $1.000 + .0012 = 1.0012$
- Lower hole limit =  $1.000 + 0 = 1.000$
- Upper shaft limit =  $1.000 - .0008 = .9992$
- Lower shaft limit =  $1.000 - .0016 = .9984$

You then dimension the hole as  $\varnothing 1.0012 - 1.0000$ , and the shaft as  $\varnothing .9992 - .9984$ .

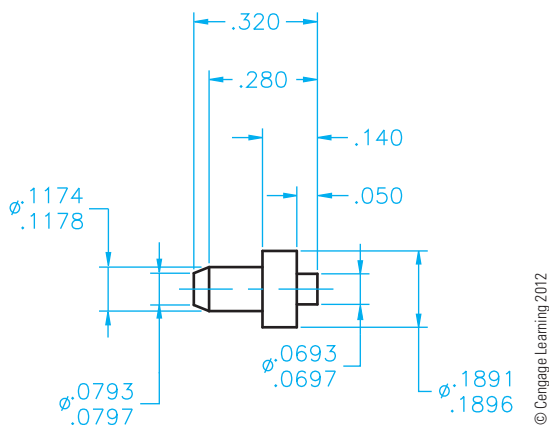
Figure 10.88 provides an actual drawing showing the use of standard ANSI fits.

### Standard ANSI/ISO Metric Limits and Fits

The standard for the control of metric limits and fits is governed by the document ANSI B4.2, *Preferred Metric Limits and Fits*.

NOMINAL SIZE RANGE IN INCHES	RC4 STANDARD TOLERANCE LIMITS	
	HOLE	SHAFT
0–.12	+0.0006	–.0003
	0	–.0007
.12–.24	+0.0007	–.0004
	0	–.0009
.24–.40	+0.0009	–.0005
	0	–.0011
.40–.71	+0.0010	–.0006
	0	–.0013
.71–1.19	+0.0012	–.0008
	0	–.0016
1.19–1.97	+0.0016	–.0010
	0	–.0020

**FIGURE 10.87** Standard RC4 fits for nominal sizes ranging from 0 to 1.97 in. Standard fit tables are given in Appendix B, Table 28. © Cengage Learning 2012



**FIGURE 10.88** An actual drawing showing the use of standard ANSI fits. The diameter dimension limits were calculated using the RC4 fits found in Figure 10.87.

The system is based on symbols and numbers relating to the internal or external application and the type of fit. The specifications and terminology for fits are slightly different from the ANSI standard fits previously described. The metric limits and fits are divided into three general categories: clearance fits, transition fits, and interference fits.

- Clearance fits are generally the same as the running and sliding fits explained earlier. With clearance fits, a clearance always occurs between the mating parts under all tolerance conditions.

TYPE OF FIT	ISO SYMBOL		DESCRIPTION OF FIT
	HOLE	SHAFT	
CLEARANCE FIT	H11/c11	C11/h11	Loose running
	H9/d9	D9/h9	Free running
	H8/f7	F8/h7	Close running
	H7/g6	G7/h6	Sliding
	H7/h6	H7/h6	Locational clearance
TRANSITION FIT	H7/k6	K7/h6	Locational transition
	H7/n6	N7/h6	Locational transition
INTERFERENCE FIT	H7/p6 <sup>1</sup>	P7/h6	Locational interference
	H7/s6	S7/h6	Medium drive
	H7/u6	U7/h6	Force

**FIGURE 10.89** Description of metric fits. Standard fit tables are given in Appendix J. © Cengage Learning 2012

- With **transition fits**, a clearance or interference can result because of the range of limits of the mating parts.
- When **interference fits** are specified, a press or force situation exists under all tolerance conditions.

Refer to Figure 10.89 for the ISO symbol and descriptions of the different types of metric fits.

The metric limits and fits are designated in a dimension one of three ways. The method used depends on individual company or school standards and the extent of use of the ISO system. When most companies begin using this system, the tolerance limits are calculated and shown on the drawing followed by the tolerance symbol in parentheses; for example, 25.000 – 24.979 (25 h7). The symbol in parentheses represents the basic size, 25, and the shaft tolerance code, h7. The term **basic size** is the dimension from which the limits are calculated, which is the same as the term *specified dimension* previously introduced.

When the feature is external as in the previous h7 shaft specification, a lowercase letter is used in the symbol. Uppercase letters are used in the symbol for internal features such as a hole. An example of the symbol for an internal feature is H7.

When companies become accustomed to using the system, they represent dimensions with the code followed by the limits in parentheses, as follows: 25 h7 (25.000 – 24.979).

Finally, when a company has used the system long enough for interpreters to understand the designations, the code is placed alone on the drawing, like this: 25 h7.

A **metric fit** is specified by providing the basic size common to the internal and external mating features, followed by a symbol corresponding to each feature. In this application, the internal feature symbol is first, followed by a backward slash, and then followed by the external features symbol—for example, 25H8/f7.

The ISO symbols for the different types of metric fits are listed as follows:

ISO Symbol		
Basic Internal	Basic External	Type of Fit
H11/c11	C11/h11	Loose running fit.
H9/d9	F8/h7	Close running fit.
H8/f7	F8/h7	Sliding fit.
H7/g6	G7/h6	Sliding fit.
H7/h6	H7/h6	Locational clearance fit.
H7/k6	K7/h6	Locational transition fit.
H7/n6	N7/h6	Additional accuracy locational transition fit.
H7/p6	P7/h6	Locational interference fit.
H7/s6	S7/h6	Medium drive fit.
H7/u6	U7/h6	Force fit.

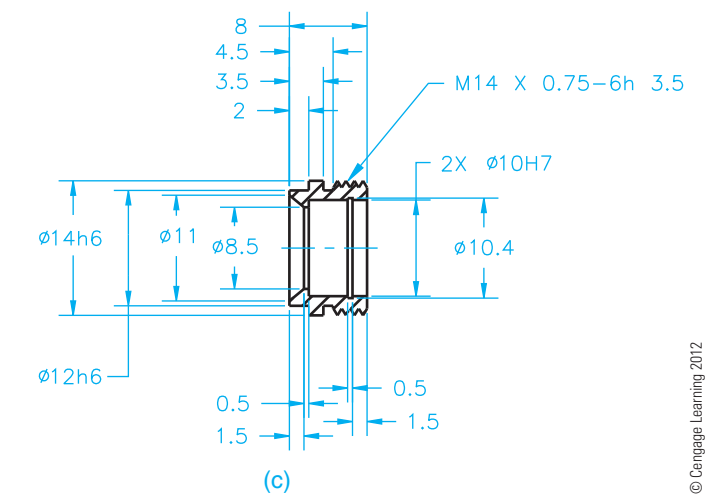
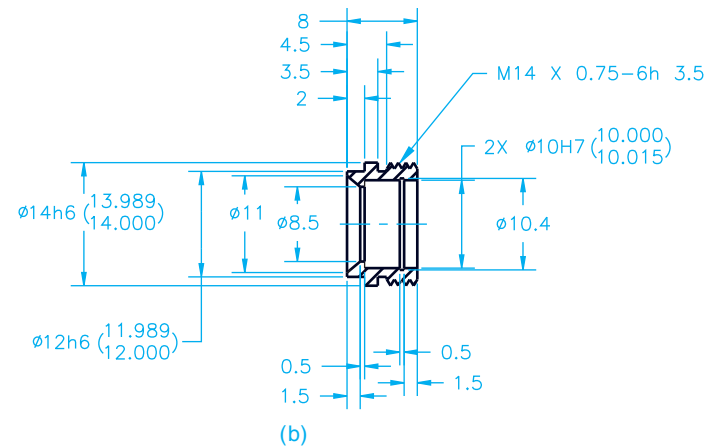
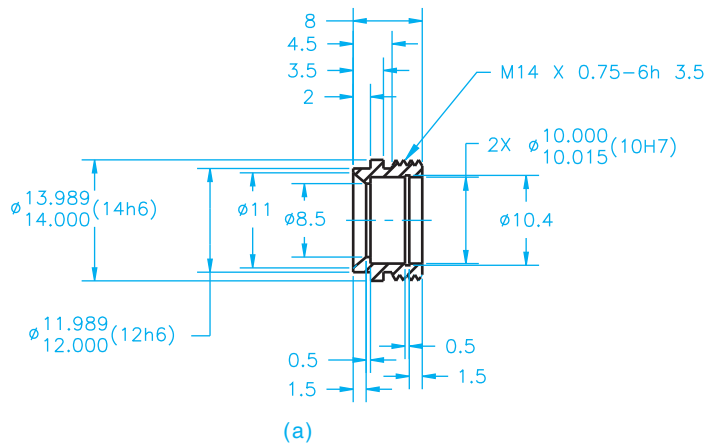
When it is necessary to determine the dimension limits from code dimensions, use the charts in Appendix I of this textbook, ANSI B4.2, or the *Machinery's Handbook*. For example, if you want to determine the limits of the mating parts with a basic size of 30 and a close running fit, refer to the chart shown in Figure 10.90. The hole limits for the 30 mm basic size are 30.033 – 30.000 (30 h8), and the shaft dimension limits are  $\varnothing 29.980 - 29.959$  (30 f7).

A drawing showing the use of the previously discussed standard ASME/ISO metric limit and fit applications is given in Figure 10.91. Figure 10.91a shows the use of the ISO system with the limits followed by the tolerance symbol in parentheses. Figure 10.91b shows the use of the ISO system

BASIC SIZE	CLOSE RUNNING FIT	
	HOLE (h8)	SHAFT (f7)
20	20.033	19.993
	20.000	19.959
25	25.033	24.980
	25.000	24.959
30	30.033	29.980
	30.000	29.959
40	40.039	39.975
	40.000	39.950
50	50.039	49.975
	50.000	49.950

**FIGURE 10.90** Tolerances of close running fits for basic sizes ranging from 20 to 50 mm. Standard fit tables are given in Appendix J.

with the tolerance symbol followed by the limits in parentheses. Figure 10.91c shows using only the ISO system tolerance symbol on the dimensions where metric limits and fits are applied.

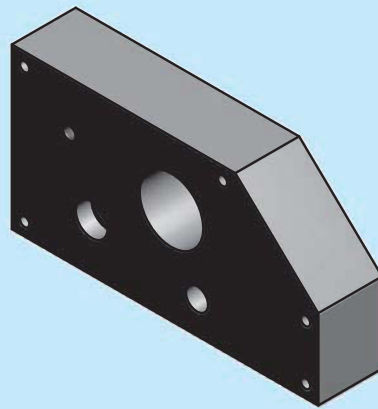
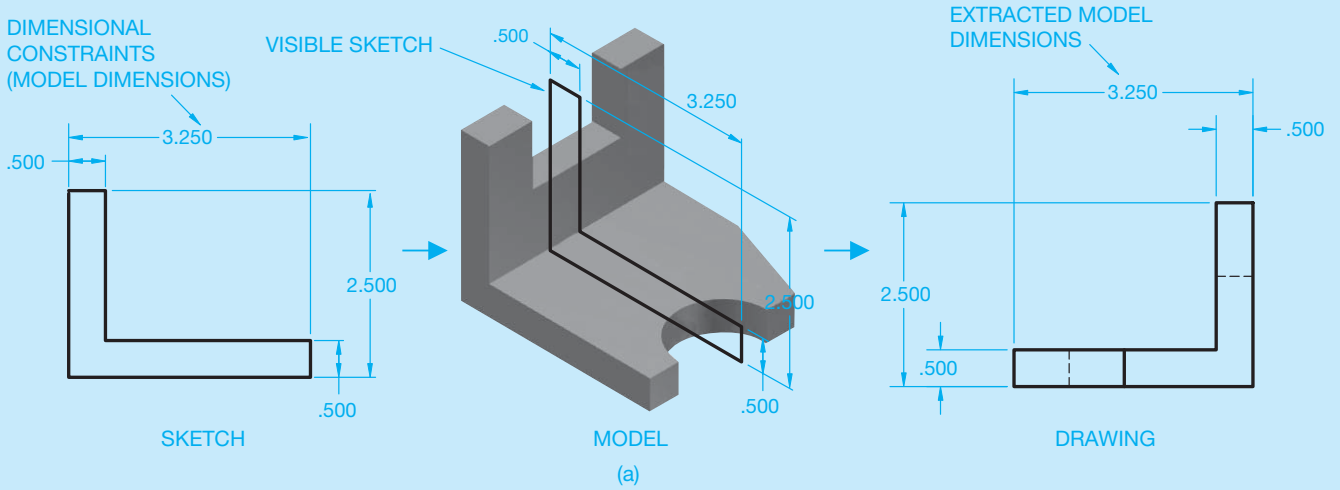


**FIGURE 10.91** A drawing showing the use of standard ASME/ISO metric limits and fits.

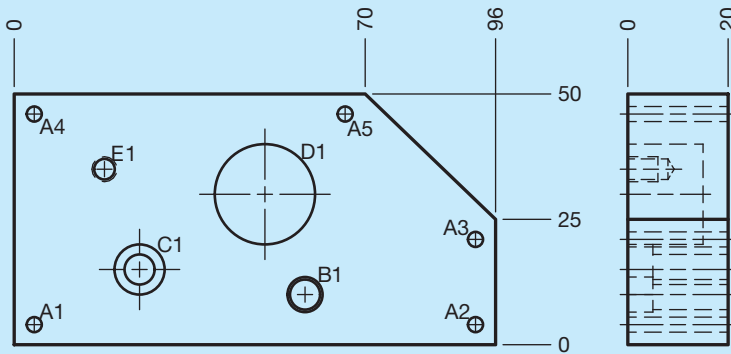
## DIMENSIONING AND TOLERANCING

The parametric 2-D drawing capabilities of some 3-D solid modeling programs allow you to extract existing model information to dimension a 2-D drawing accurately and

easily. The model that you reference to create drawing views includes parameters that you can extract and use as **model dimensions**. Model dimensions are model parameters, such as dimensional constraints and feature specifications, that are available to use as dimensions in a drawing (see Figure 10.92a). Every time you create a feature, a model



MODEL



DRAWING (b)

HOLE TABLE			
HOLE	XDIM	YDIM	DESCRIPTION
A1	4.00	4.00	Ø3 THRU
A2	92.00	4.00	Ø3 THRU
A3	92.00	21.00	Ø3 THRU
A4	4.00	46.00	Ø3 THRU
A5	66.00	46.00	Ø3 THRU
B1	58.00	10.00	Ø6 THRU ⊥Ø7 ∇5
C1	25.00	15.00	Ø6 THRU ⊥Ø10 ∇5
D1	50.00	30.00	Ø20 15
E1	18.00	35.00	M5x0.8-6H∇6

**FIGURE 10.92** (a) An example of model dimensions extracted to a drawing view. Dimension values in this figure are in inches. (b) Using model and drawing dimensions to dimension a part drawing using tabular dimensioning practices.

(Continued)

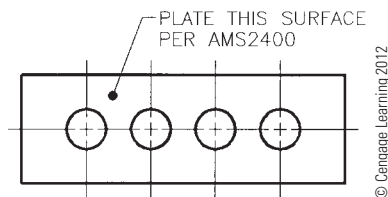
dimension is stored in the system. The depth of an extrusion, diameter of a cylinder, and location of a hole are all examples of model dimensions. You may also have the option of adding tolerances to model size and location dimensions. You can edit parametric model dimensions in the drawing to make changes to the size and shape of the model.

You can usually only extract or retrieve model dimensions that are planar to the drawing view. For example, you can show the model dimension that defines the part thickness in the view that displays the thickness (see Figure 10.92a). Depending on the CADD system, you may have the option to add model dimensions during view placement. Automatic means of retrieving model dimensions are effective for some applications. However, often you want additional control over the dimensions that appear or to acquire model dimensions formed after initial view placement. Most software offers additional tools to extracting model dimensions that provides this level of flexibility.

**Drawing dimensions** are dimensions you place as an alternative or in addition to model dimensions to fully

describe the drawing. Add drawing dimensions when model dimensions do not fully document design intent or are not appropriate according to correct drafting practices. Most programs provide many tools and options for annotating a drawing. Tools are available for specific dimensioning methods. You can add dimensions, notes, symbols, and tables required for most drawing applications.

Unlike model dimensions, you cannot control model parameters using drawing dimensions. However, drawing dimensions associate with model geometry. If you modify model parameters in the model file drawing and model, dimensions in the drawing adjust to the changes. Figure 10.92b shows an example of using a rectangular coordinate dimensioning without dimension lines tool and a hole table tool to dimension a part drawing. In this example, the rectangular coordinate dimensions without dimension lines are drawing dimensions associated with view geometry. The coordinates and descriptions in the hole table are model dimensions.



**FIGURE 10.93** A dot replaces the arrowhead on a leader connecting a specific note to a surface.

## DIMENSIONS APPLIED TO PLATINGS AND COATINGS

When platings such as chromium, copper, and brass, or coatings such as galvanizing, polyurethane, and silicone are applied to a part or feature, the specified dimensions should be defined in relation to the coating or plating process. A general note that indicates the dimensions apply before or after plating or coating is commonly used and specifies the desired variables. For example, DIMENSIONAL LIMITS APPLY BEFORE (AFTER) PLATING (COATING). A leader connecting a specific note to a surface can also be used for specific applications. Notice the dot replaces the arrowhead when the leader points to the surface in Figure 10.93. The dot is .06 in. (1.5 mm) minimum in diameter.

## MAXIMUM AND MINIMUM DIMENSIONS

In some situations, a dimension with an unspecified tolerance requires that the general tolerance is applied between zero and the specified dimension. For example, when a 12 mm radius

shall not exceed 12 mm, the dimension reads R12 MAX. If a dimension of R12 MAX is given, it means the radius can be between zero and 12 mm. It does not mean that the general tolerance is applied in one direction. Therefore, when it is desirable to establish a maximum or minimum dimension, the abbreviations MAX or MIN are applied to the dimension. A dimension with a specified tolerance reads as previously discussed, for example:

$$R12 \begin{matrix} 0 \\ -0.05 \end{matrix}, \text{ or } R12 \begin{matrix} +0.05 \\ 0 \end{matrix}.$$

## CASTING DRAWING AND DESIGN

A review of Chapter 4, *Manufacturing Materials and Processes*, is recommended before proceeding to the next few sections.

The result of a casting drawing is the fabrication of a pattern. The preparation of casting drawings depends on the casting process used, the material to be cast, and the design or shape of the part. When doing this, you make the drawing of the part the same as the desired result after the part has been cast. A casting is a part obtained by solidification of material in a die or mold. A die is any device used to produce a desired shape, form, or finish to a material. A mold is a form made to pour or inject material to produce the desired shape. You also need to consider certain casting characteristics, and the pattern maker needs to adjust the size and shape of the pattern to take into account characteristics that you do not intentionally apply on the drawing.



## STANDARDS

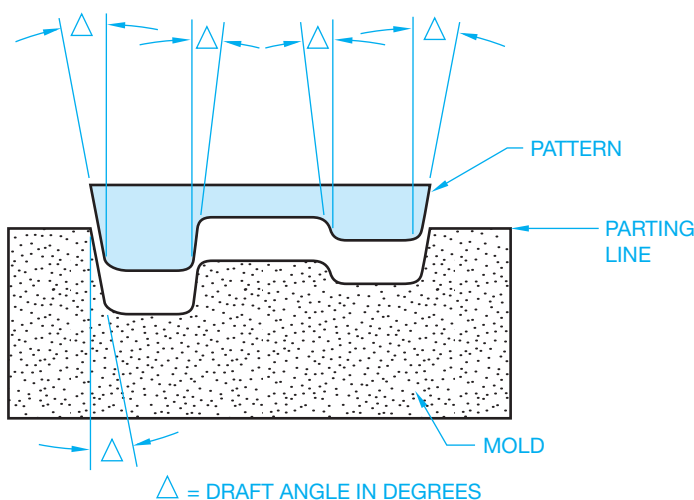
**ASME Standards for the drafting of castings and forgings are recommended in ASME Y14.8-2009, *Castings, Forgings, and Molded Parts*. This standard covers definitions and features unique to casting and forging and molded part technologies and provides recommendations for uniform specifications on engineering drawings and related documents. A general note should be placed on the casting, forging, or molded part drawing that reads **PREPARED IN ACCORDANCE WITH ASME Y14.8-2009**.**

## Shrinkage Allowance

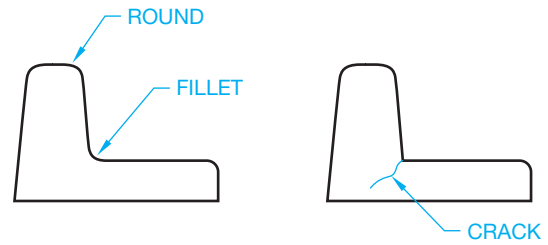
When metals are heated and then cooled, they shrink until the final temperature is reached. The amount of shrinkage depends on the material used. The shrinkage for most iron is about .125 in. per ft. (0.4 mm per meter), .250 in. per ft. for steel, .125 to .156 in. per ft. (0.4–0.5 mm per meter) for aluminum, .22 in. per ft. (0.7 mm per meter) for brass, and .156 in. per ft. (.5 mm per meter) for bronze. Values for shrinkage allowance are approximate because the exact allowance depends on the size and shape of the casting and the contraction of the casting during cooling. You normally do not need to consider shrinkage because the pattern maker applies shrink rules that use expanded scales to take into account the shrinkage of various materials.

## Draft

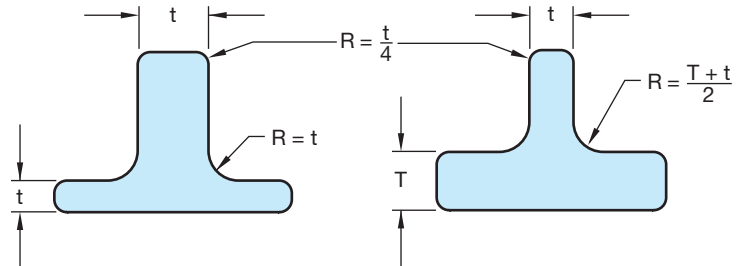
**Draft** is the taper allowance on all vertical surfaces of a pattern, which is necessary to facilitate the removal of the pattern from the mold. Draft is not necessary on horizontal surfaces because the pattern easily separates from these surfaces without sticking. Draft angles begin at the **parting line** and **parting plane** and taper away from the molding material (see Figure 10.94). The parting line is the separation between the mold or die components and is a line on the drawing representing the mating surfaces between the mold or die components. A parting plane represents the mating surfaces of a die or mold. The draft is added to the



**FIGURE 10.94** Draft angles for castings. © Cengage Learning 2012



**FIGURE 10.95** Fillets and round for castings.



**FIGURE 10.96** Recommended fillet and round radii for sand castings. © Cengage Learning 2012

minimum design sizes of the product. Draft varies with different materials, size and shape of the part, and casting methods. For example, little if any draft is necessary in investment casting. The factors that influence the amount of draft are the height of vertical surfaces, the quality of the pattern, and the ease with which the pattern must be drawn from the mold. A typical draft angle for cast iron and steel is .125 in. per ft. Whether you consider draft on a drawing depends on company standards. Some companies leave draft angles to the pattern maker, whereas others require you to place draft angles on the drawing.

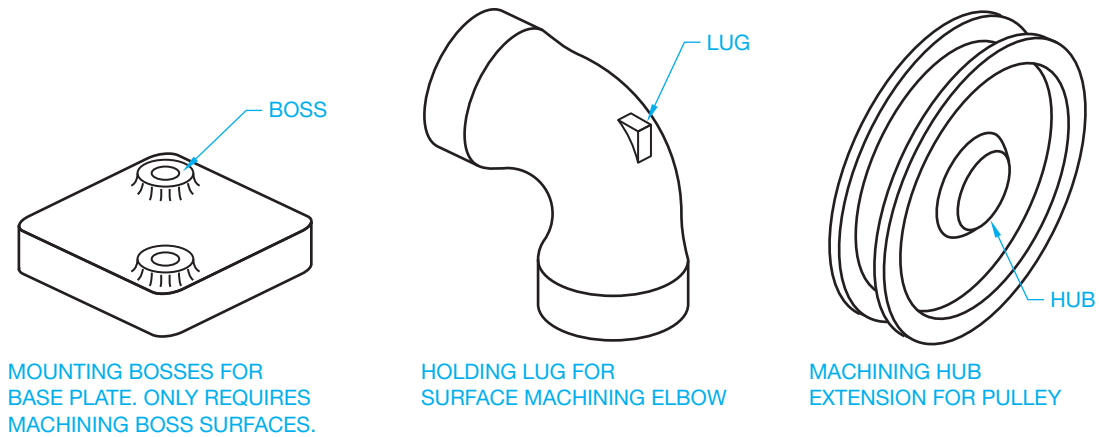
## Fillets and Rounds in Casting

One of the purposes of fillets and rounds on a pattern is the same as draft angles: allow the pattern to eject freely from the mold. The use of fillets on inside corners also helps reduce the tendency of cracks to develop during shrinkage (see Figure 10.95). In most applications, all surface intersections and inside corners should have fillets and rounds. The radius for fillets and rounds depends on the material to be cast, the casting method, and the thickness of the part. The recommended radii for fillets and rounds used in sand casting is determined by part thickness as shown in Figure 10.96.

## MACHINING ALLOWANCE

Extra material must be left on the casting for any surface to be machined. As with other casting design characteristics, the machining allowance depends on the casting process, material, size, and shape of the casting, and the machining process to be used for finishing. The standard finish allowance for iron and steel is .125 in. (3 mm) and .062 in. (1.5 mm) for nonferrous metals such as brass, bronze, and aluminum. In some situations, the finish allowance can be as much as .5 to .75 in. (12 to 20 mm) for castings that are very large or have a tendency to warp.

Other machining allowances are the addition of lugs, hubs, or bosses on castings that are otherwise hard to hold. You can



**FIGURE 10.97** Cast features added for machining. © Cengage Learning 2012

add these items to the drawing or the pattern maker can add them to the pattern. These features may or may not be added for product function, but they serve as aids for chucking or clamping the casting in a machine (see Figure 10.97).

## CASTING DRAWINGS

There are several methods used to prepare drawings for casting and machining operations. The method used depends on company standards. A commonly used technique is to prepare two drawings, one a casting drawing and the other a machining drawing.

### Casting Drawing

The **casting drawing** shows the part as a casting as in Figure 10.98. Only dimensions necessary to make the casting are shown in the casting drawing. The preferred method recommended by ASME is to show casting and machining on separate drawings.

### Machining Drawing

When a cast part requires machining and a separate casting drawing is used, a machining drawing is required. Only dimensions necessary to machine surfaces or features on the casting are shown in the machining drawing. The actual casting goes to the machine shop along with the machining drawing so the features can be machined as specified. The machining drawing, for the casting in Figure 10.98, is shown in Figure 10.99.

## Combined Casting and Machining Drawing

Another method of preparing casting and machining drawings is to show both casting and machining information together on one drawing. This technique requires the **pattern maker** to add machining allowances. The drawing can have draft angles specified in the form of a note. The pattern maker must add the draft angles to the finished sizes given. With draft angles and finish allowances omitted, you need to consult with the pattern maker to ensure the casting is properly made. A combination casting and machining drawing is shown in Figure 10.100. A pattern maker is a person who makes a **pattern** for casting and forging

applications. A pattern is a form made of wood, metal, or other material around which a material is placed to make a mold.

## Drawing Phantom Lines to Show Machining Allowance and Draft Angles

Another technique is to draw the part as a machining drawing and then use phantom lines to show the extra material for machining allowance and draft angles as shown in Figure 10.101.

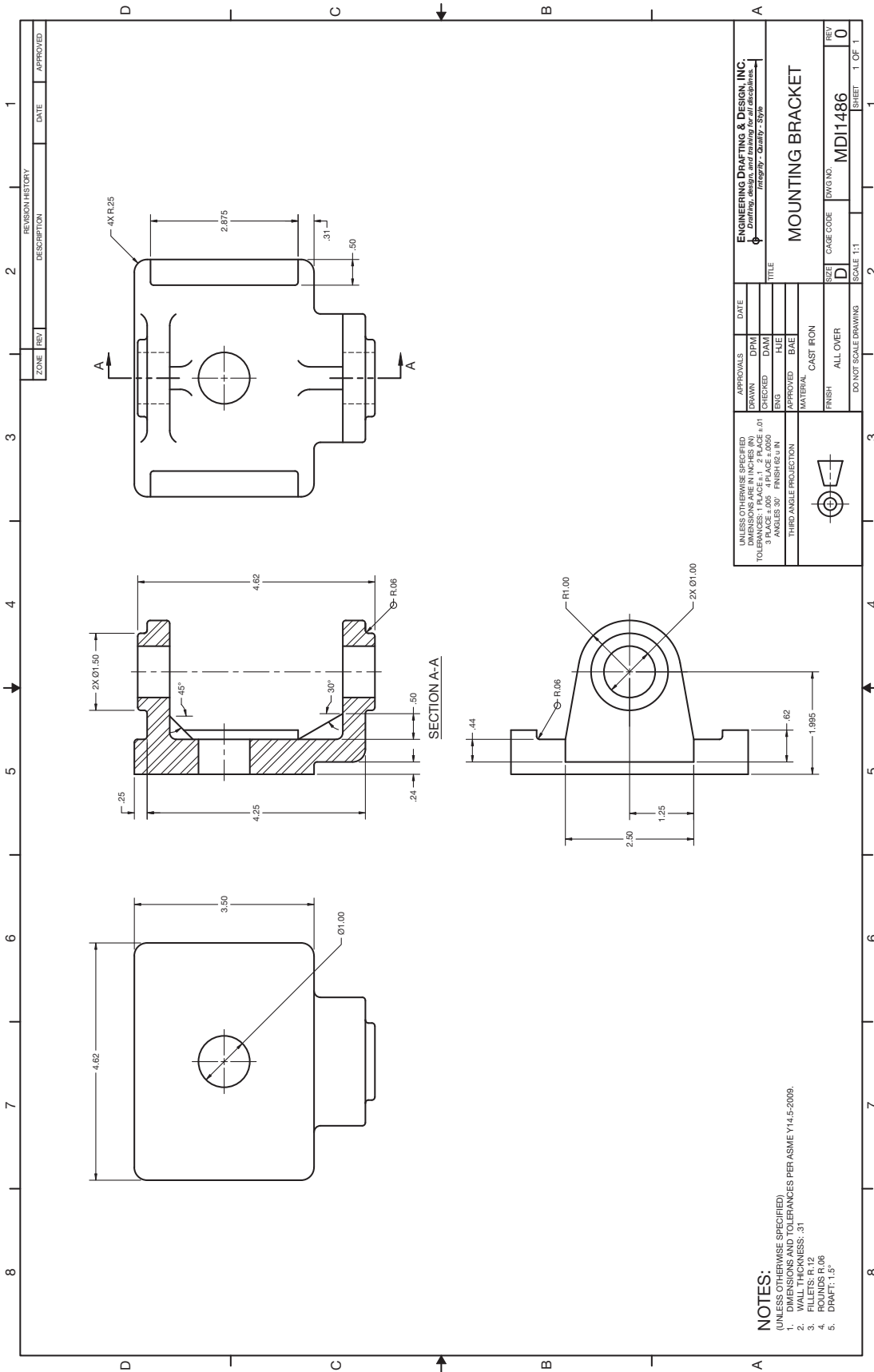
## FORGING, DESIGN, AND DRAWING

Draft for **forgings** serves much the same purpose as draft for castings. Forging is a process of shaping malleable metals by hammering or pressing between dies that duplicate the desired shape. The draft associated with forging is found in the dies. The sides of the dies must be angled to help the release of the metal during the forging process. If the vertical sides of the dies do not have draft angle, then the metal sticks in the die. Internal and external draft angles can be specified differently because the internal drafts in some materials have to be greater to help reduce the tendency of the part to stick in the die. Although draft angles can change slightly with different materials, the common exterior draft angle recommended is  $7^\circ$ . The internal draft angles for most soft materials is also  $7^\circ$ , but the recommended interior draft for iron and steel is  $10^\circ$ .

The application of fillets and rounds to forging dies is to improve the ejection of the metal from the die. Another reason, similar to that for casting, is increased inside corner strength. One factor that applies to forgings as different from castings is that fillets and rounds that are too small in forging dies can substantially reduce the life of the dies. Recommended fillet and round radius dimensions are shown in Figure 10.102.

### Forging Drawings

A number of methods can be used in the preparation of forging drawings. One technique used in forging drawings that is clearly different from the preparation of casting drawings is the addition of draft angles. Casting drawings usually do not show draft angles. Forging detail drawings usually do show draft.



Courtesy Engineering Drafting & Design, Inc.

**FIGURE 10.98** Casting drawing. Dimension values in this figure are in inches.

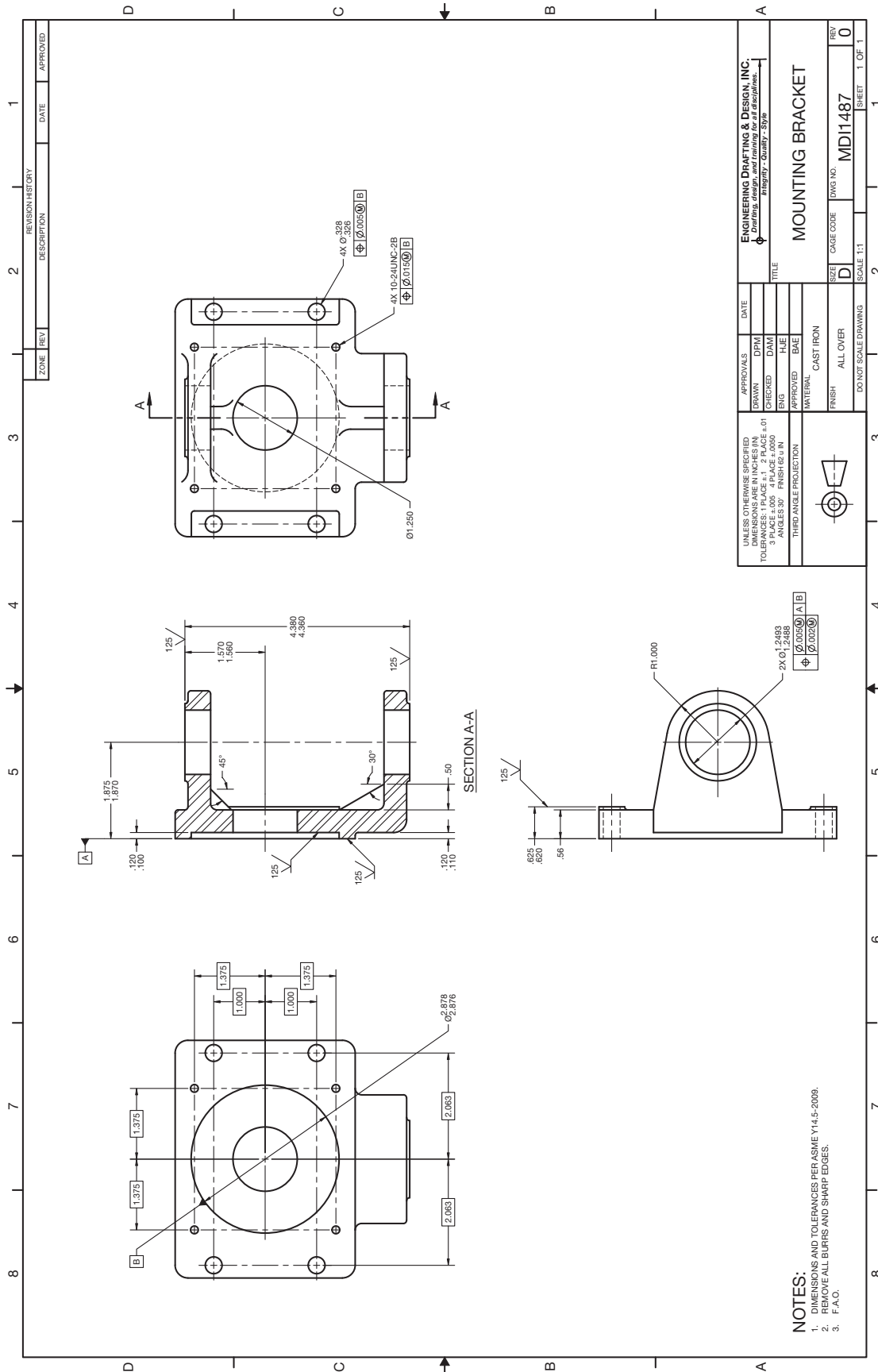
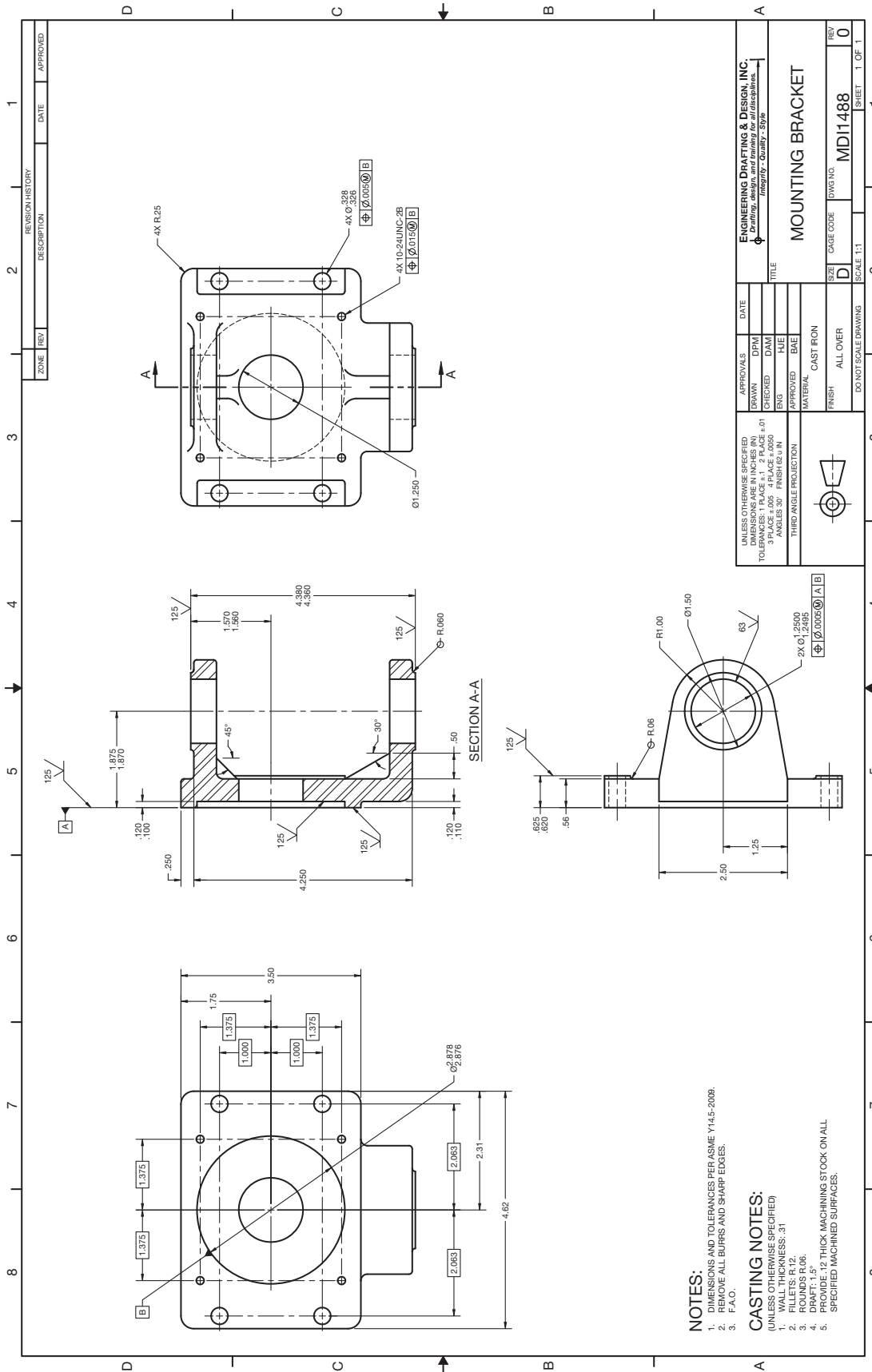
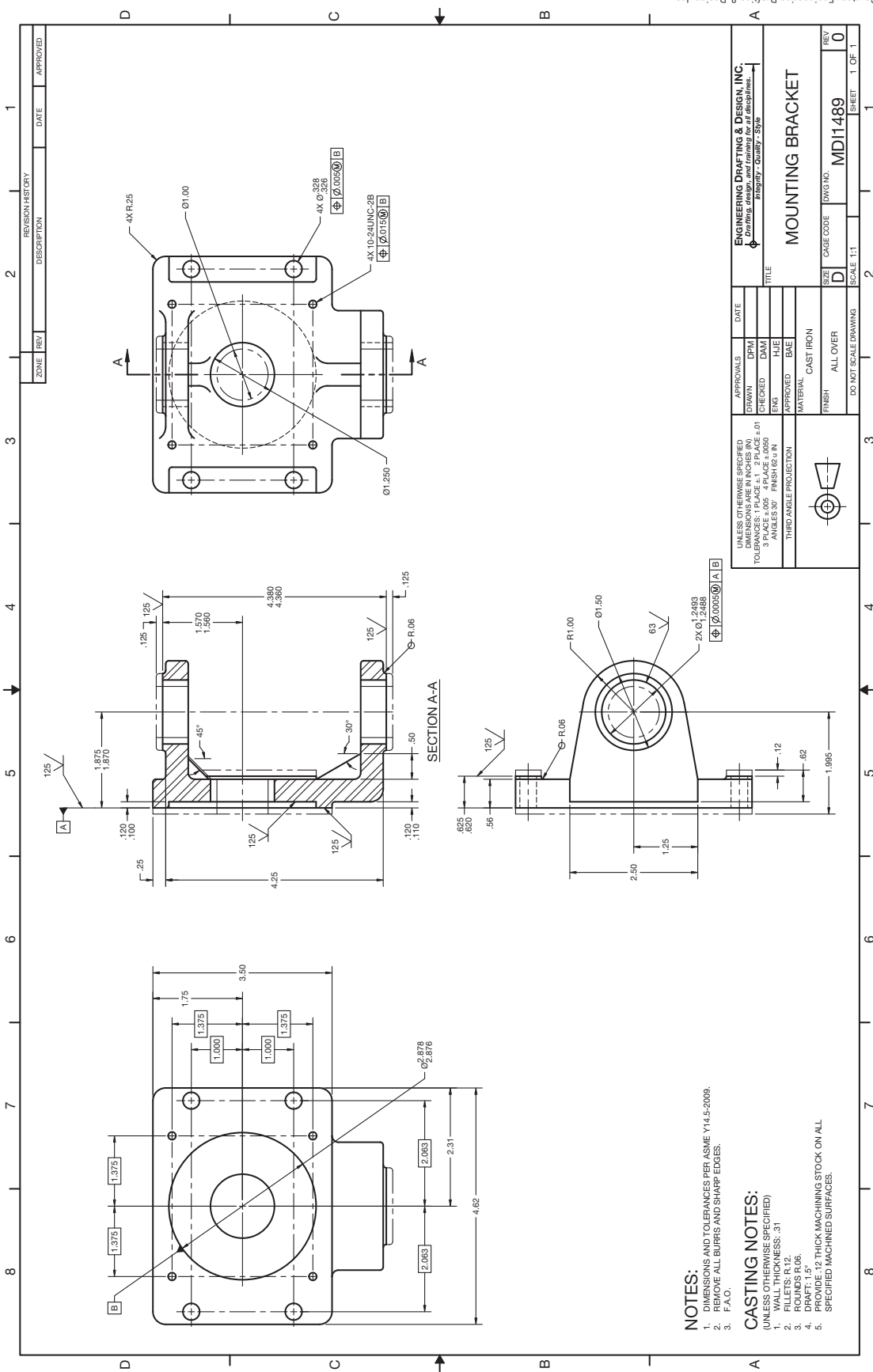


FIGURE 10.99 Machining drawing. Dimension values in this figure are in inches.



Courtesy Engineering Drafting & Design, Inc.

FIGURE 10.100 Drawing with casting and machining information. Dimension values in this figure are in inches.



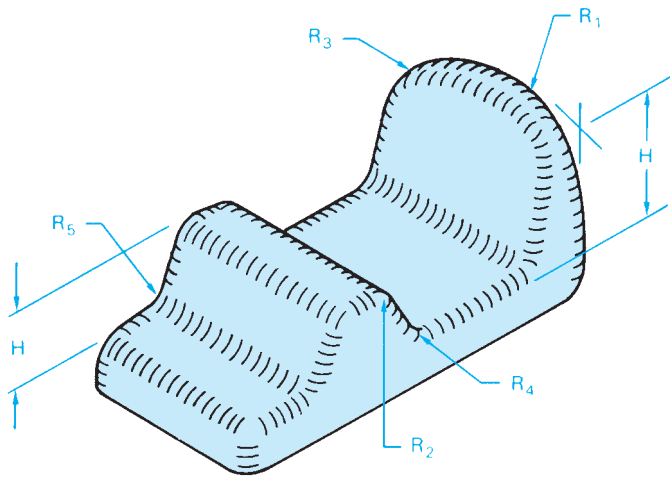
Courtesy Engineering Drafting & Design, Inc.

FIGURE 10.101 Phantom lines used to show machining allowances. Dimension values in this figure are in inches.

Before a forging can be made, the dimensions of the stock material to be used for the forging must be determined. Some companies leave this information to the forging shop to determine. Other companies have their engineering department make these calculations. After the stock size is determined, a drawing showing size

and shape of the stock material is prepared. The blank material is dimensioned, and the outline of the end product is drawn inside the stock view using phantom lines (see Figure 10.103).

Forgings are made with extra material added to surfaces that must be machined. Forging detail drawings are made to show the desired end product with the outline of the forging shown in phantom lines at areas that require machining (see Figure 10.104). Notice the double line around the perimeter showing draft angle. Another option used by some companies



DIMENSIONS IN MILLIMETERS					
H	R <sub>1</sub>	R <sub>2</sub>	R <sub>3</sub>	R <sub>4</sub>	R <sub>5</sub>
6	1.5	1.5	4.5	3	3
13	1.5	1.5	4.5	3	3
25	3	3	9	6	9
50	4.5	6	13	13	15
75	6	7.5	16	16	25
100	7.5	10.5	25	25	35
125	9	13	23	32	44
150	10.5	15	32	38	50

FIGURE 10.102 Recommended fillets and rounds for forgings.

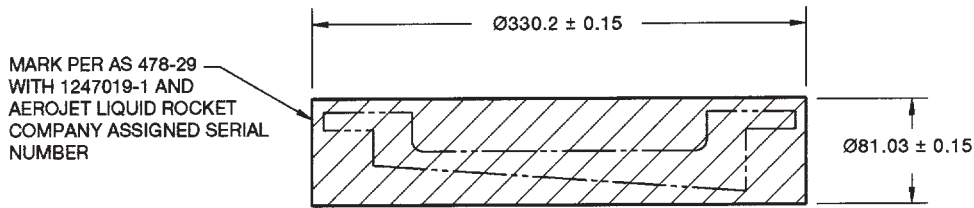


FIGURE 10.103 Blank material for forging process.

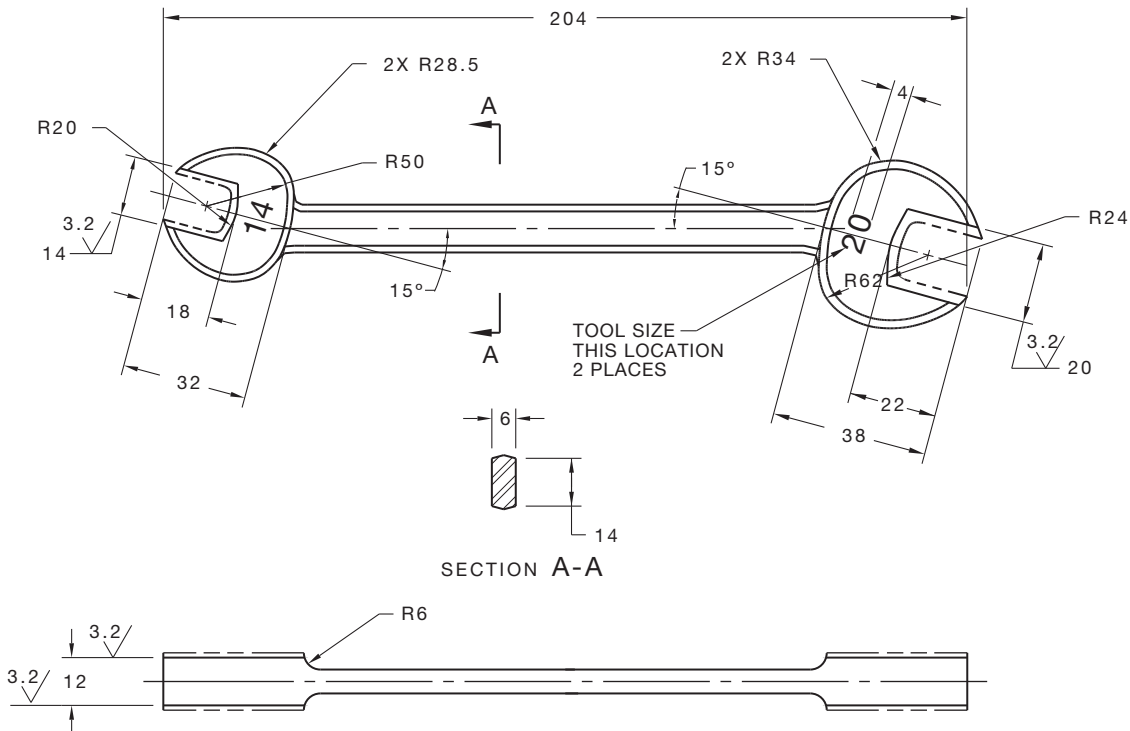


FIGURE 10.104 Phantom lines used to show machining allowance on a forging drawing.

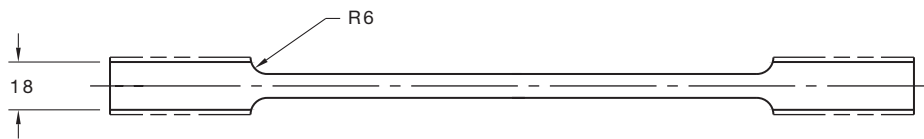
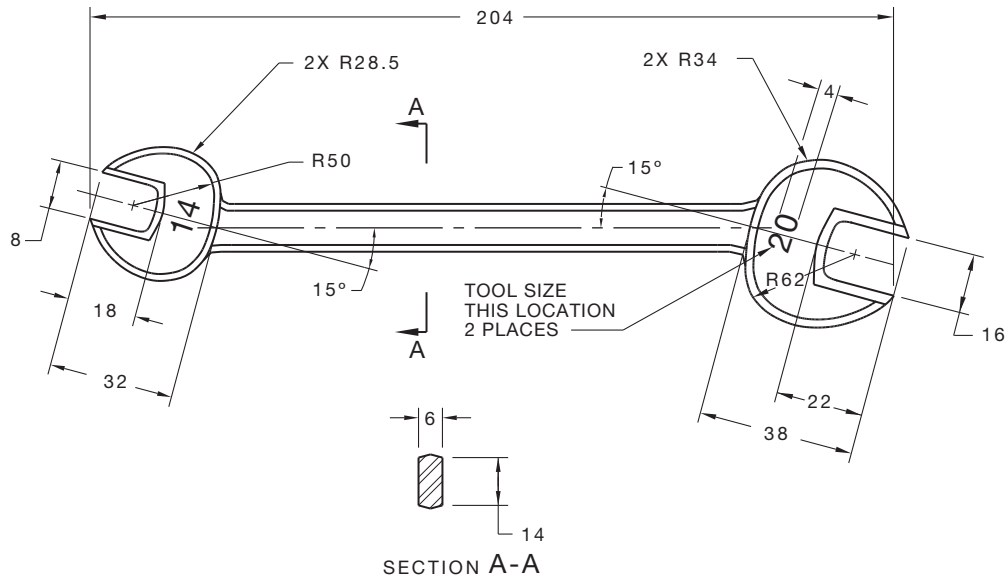


FIGURE 10.105 Forging drawing with forging dimensions only.

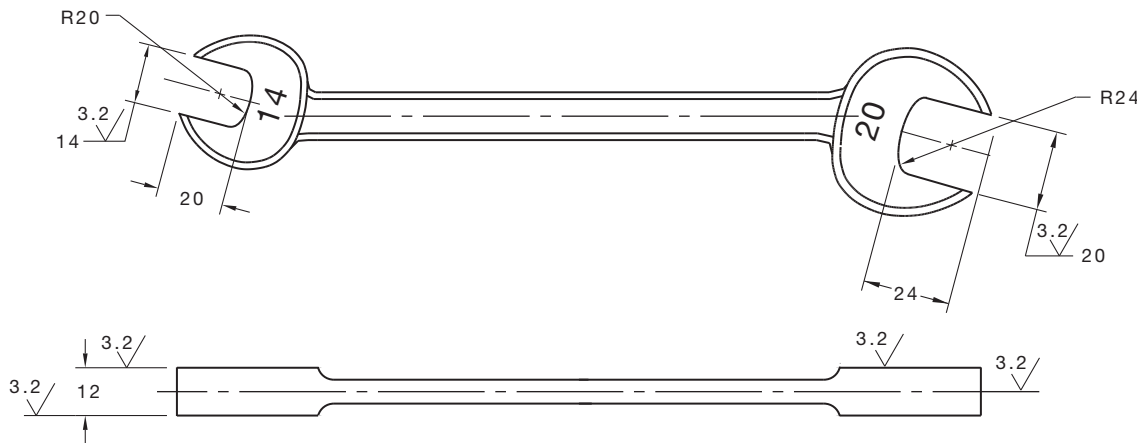


FIGURE 10.106 Machining drawing with machining dimensions only.

is to make two separate drawings, one a forging drawing and the other a machining drawing. The forging drawing shows all of the views, dimensions, and specifications that relate only to the production of the forging, as shown in Figure 10.105. The machining drawing gives views, dimensions, and specifications related to the machining processes, as shown in Figure 10.106.

## DRAWINGS FOR PLASTIC PART MANUFACTURING

As discussed in Chapter 4, there is a wide variety of plastic materials and manufacturing processes for creating plastic parts. Much like castings and forgings of metal parts, plastic

manufacturing often requires draft angles to be applied to the design. This depends on the type of plastic and the manufacturing method used. Draft angles allow the finished plastic part to be ejected or removed from the mold without difficulty. A parting line is associated with plastic molded parts and with metal castings and forgings. A parting line can be placed on the drawing to represent the mating surfaces of the die or mold components, and it is used in the same manner on castings, forgings and molded parts. The parting line can be drawn using a phantom line type, and it can have a parting line symbol placed on the parting line. Figure 10.107 shows examples of parting lines used on drawings. Figure 10.107 details the proper parting line symbol.



Draft angles can be specified in a note, such as .010 MAX DRAFT ANGLE. In this case, the pattern maker uses this amount of draft as a guide and produces a pattern that has draft angles that are less than .010 on each side where needed for the manufacturing process. These draft angles are generally established within the specified part dimensions rather than added

on to the part dimensions. A draft angle tolerance can also be specified as a zone. This can be shown on the drawing as in Figure 10.108, or it can be specified as a tolerance in a general note or in the title block. A general note might read: ALL DRAFT ANGLES .010, or ALL DRAFT ANGLES 6°. The engineer or the mold maker determines the amount of draft angle.

Another method of specifying draft is the plus draft and minus draft methods. This is abbreviated as +DFT or -DFT and is placed with the feature dimensions on the part. In the DFT application, the draft is added to the dimension for external dimensions and removed from internal dimensions as shown in Figure 10.109a. In the -DFT method, the draft is removed from the external dimension and added to the internal dimension as shown in Figure 10.109b. Both +DFT and -DFT can be combined on a drawing as shown in Figure 10.109c.

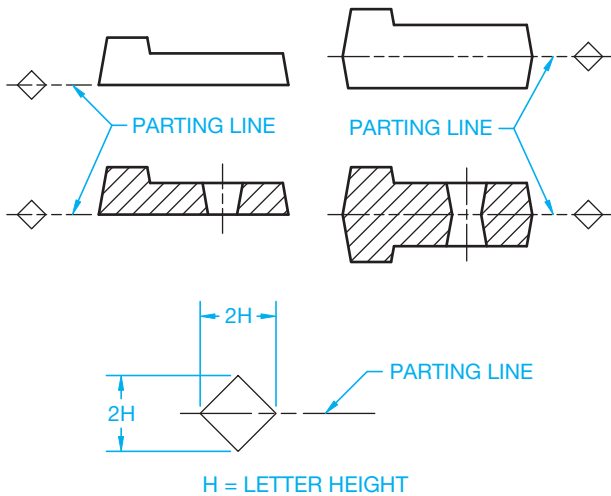


FIGURE 10.107 Parting lines labeled on example drawings.

### MACHINED SURFACES

As you learned in Chapter 4, *Manufacturing Materials and Processes*, there are a wide variety of machine tools available to produce parts in manufacturing. A review of the machine tools and machining processes discussed in Chapter 4 is recommended.

### Surface Finish Definitions

**Surface finish** or **surface texture** is the intended condition of the material surface after the machining processes have been completed. Surface texture includes such characteristics as roughness, waviness, lay, and flaws.

### Surface Finish

Surface finish refers to the roughness, waviness, lay, and flaws of a surface. Surface finish is the specified smoothness required

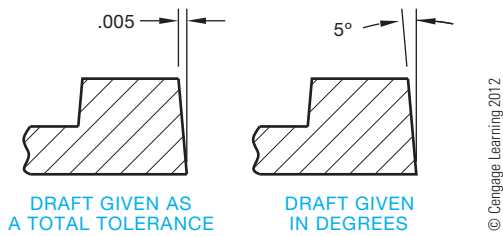


FIGURE 10.108 Draft angle tolerances shown on a drawing. Dimension values in this figure are in inches.

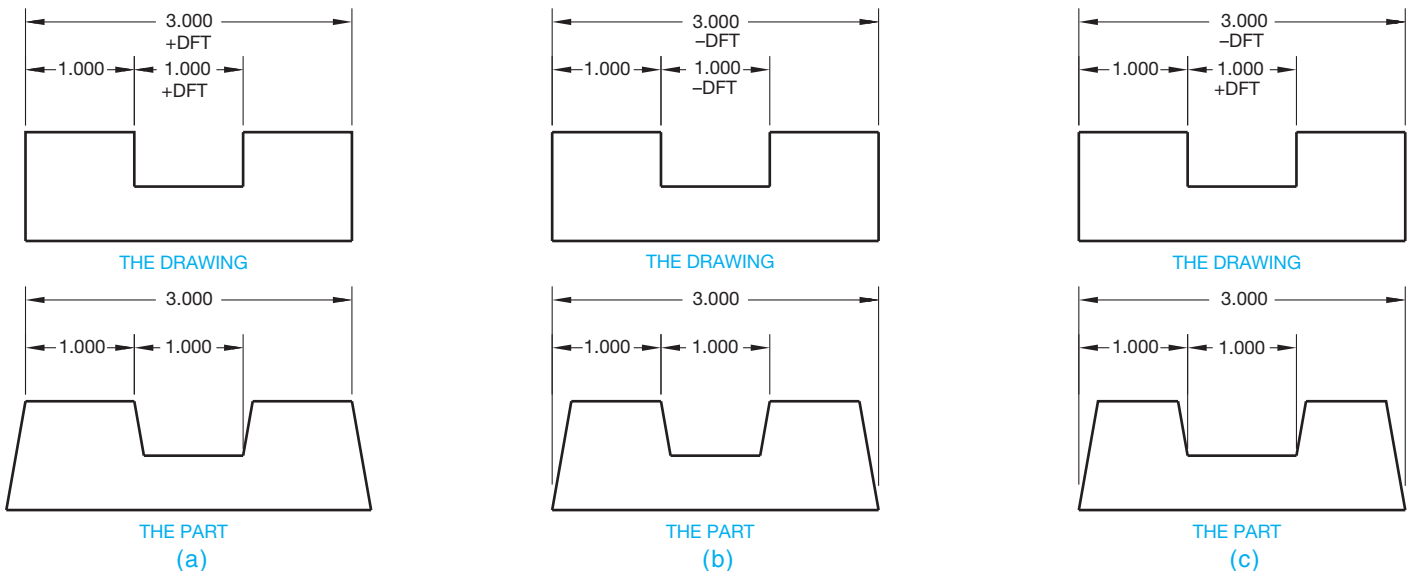


FIGURE 10.109 Draft can be specified on a drawing with (a) the plus draft method, (b) the minus draft method, or (c) a combination of both methods. Dimension values in this figure are in inches. © Cengage Learning 2012

on the finished surface of a part that is obtained by machining, grinding, honing, or lapping. Figure 10.110 shows the drawing symbol associated with surface finish.

**Lay**

**Lay** is the term used to describe the direction or configuration of the predominant surface pattern. The lay symbol is used if considered essential to a particular surface finish. The characteristic lay symbol can be attached to the surface finish symbol, as shown in Figure 10.111.



FIGURE 10.110 Surface finish symbol. © Cengage Learning 2012

ILLUSTRATION	DEFINITION	SYMBOL
	PARALLEL TO EDGE OF INDICATED SURFACE	
	PERPENDICULAR TO EDGE OF INDICATED SURFACE	
	ANGULAR IN BOTH DIRECTION TO INDICATED EDGE	
	CIRCULAR RELATIVE TO CENTER	
	MULTIDIRECTIONAL	
	RADIAL RELATIVE TO CENTER	

FIGURE 10.111 Characteristic lay added to the surface finish symbol. © Cengage Learning 2012

**Surface Finish Symbol**

Some of the surfaces of an object are machined to certain specifications. When this is done, a surface finish symbol is placed on the view where the surface or surfaces appear as lines, which is an edge view (see Figure 10.112). The finish symbol on a machine drawing alerts the machinist that the surface must be machined to the given specification. The finish symbol also tells the pattern maker or die maker that extra material is required in a casting or forging.

The surface finish symbol is properly drawn using a thin line as detailed in Figure 10.113. The numerals or letters associated with the surface finish symbol should be the same height as the lettering used on the drawing dimensions and notes.

Often only the surface roughness height is used with the surface finish symbol. For example, 3.2 means 3.2 micrometers. When other characteristics of a surface texture are specified, they are shown in the format represented in Figure 10.114 for a

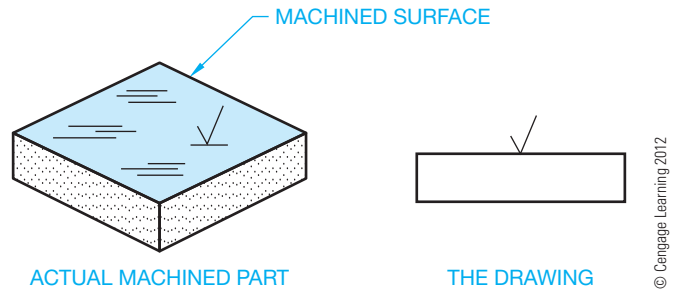


FIGURE 10.112 Standard surface finish symbol placed on the edge view. The symbol should always be placed horizontally when unidirectional dimensioning is used.

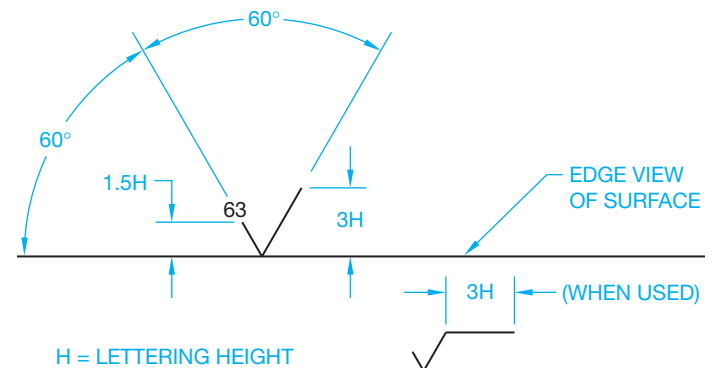


FIGURE 10.113 Properly drawn surface finish symbol. © Cengage Learning 2012

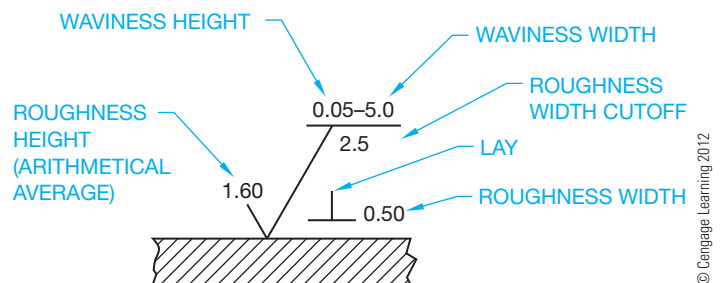


FIGURE 10.114 Elements of a complete surface finish symbol.

metric drawing. The values are in microinches when used on an inch drawing. For example, roughness width cutoff is a numerical value establishing the maximum width of surface irregularities to be included in the roughness height measurement. Standard roughness width cutoff values for inch specifications are .003, .010, .030, .100, .300, and 1.000; .030 is implied when no specification is given.

### Surface Roughness

Surface roughness refers to fine irregularities in the surface finish and is a result of the manufacturing process used. Roughness height is measured in micrometers,  $\mu$ m (millionths of a meter), or in microinches,  $\mu$ in (millionths of an inch). (See Figure 10.114.)

### Surface Waviness

Surface waviness is the often widely spaced condition of surface texture usually caused by such factors as machine chatter, vibrations, work deflection, warpage, or heat treatment. Waviness is rated in millimeters or inches (see Figure 10.114).

## Characteristics of a Surface Finish Symbol

Figure 10.115 is a magnified pictorial representation showing the characteristics of a surface finish symbol. Figure 10.116 shows some common roughness height values in micrometers

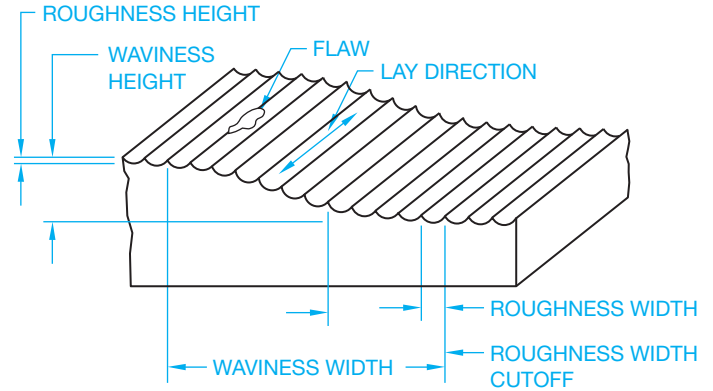


FIGURE 10.115 Surface finish characteristics magnified. © Cengage Learning 2012

MICROMETERS	ROUGHNESS HEIGHT RATING MICRO INCHES	SURFACE DESCRIPTION	PROCESS
25 ✓	1000 ✓	VERY ROUGH	SAW AND TORCH CUTTING, FORGING, OR SAND CASTING.
12.5 ✓	500 ✓	ROUGH MACHINING	HEAVY CUTS AND COARSE FEEDS IN TURNING, MILLING, AND BORING.
6.3 ✓	250 ✓	COARSE	VERY COARSE SURFACE GRIND, RAPID FEEDS IN TURNING, PLANING, MILLING, BORING, AND FILING.
3.2 ✓	125 ✓	MEDIUM	MACHINING OPERATIONS WITH SHARP TOOLS, HIGH SPEEDS, FINE FEEDS, AND LIGHT CUTS.
1.6 ✓	63 ✓	GOOD MACHINE FINISH	SHARP TOOLS, HIGH SPEEDS, EXTRA-FINE FEEDS AND CUTS.
0.80 ✓	32 ✓	HIGH-GRADE MACHINE FINISH	EXTREMELY FINE FEEDS AND CUTS ON LATHE, MILL, AND SHAPERS REQUIRED. EASILY PRODUCED BY CENTERLESS, CYLINDRICAL, AND SURFACE GRINDING.
0.40 ✓	16 ✓		
0.20 ✓	8 ✓	VERY FINE MACHINE FINISH	FINE HONING AND LAPPING OF SURFACE.
0.050 ✓ 0.100 ✓	2-4 ✓	EXTREMELY SMOOTH MACHINE FINISH	EXTRA-FINE HONING AND LAPPING OF SURFACE. MIRROR FINISH.
0.025 ✓	1 ✓	SUPER FINISH	DIAMOND ABRASIVES.

FIGURE 10.116 Common roughness height values with a surface description and associated machining process.

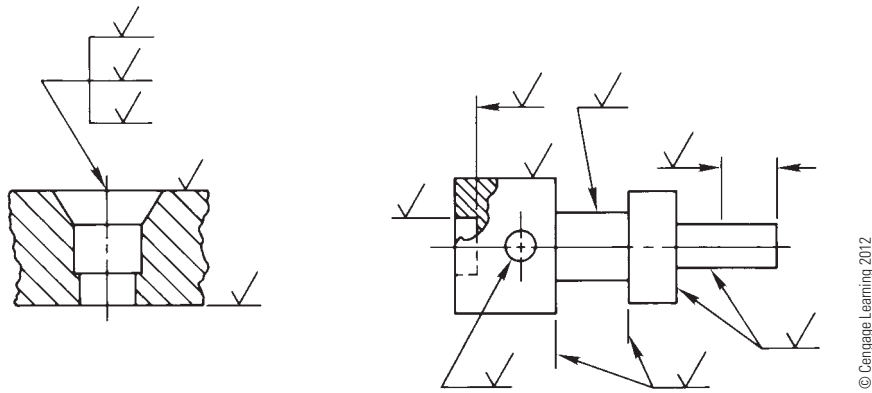


FIGURE 10.117 Proper placement of surface finish symbols.

- ✓ STANDARD SURFACE FINISH SYMBOL WITH ROUGHNESS HEIGHT ONLY SPECIFIED.
- ✓ SYMBOL DENOTES MATERIAL REMOVAL BY MACHINING IS REQUIRED, AND EXTRA MATERIAL MUST BE PROVIDED FOR THAT PURPOSE.
- 2.5 ✓ THE NUMBER TO THE LEFT OF THE SYMBOL MAY BE USED TO SPECIFY THE AMOUNT OF STOCK TO BE REMOVED BY MACHINING. GIVEN IN MILLIMETERS OR IN INCHES.
- ✓ THE SYMBOL DENOTES THAT MATERIAL REMOVAL IS PROHIBITED. THE SURFACE MUST BE PRODUCED BY PROCESSES SUCH AS CASTING OR FORGING.

FIGURE 10.118 Material removal elements added to the surface finish symbol. © Cengage Learning 2012

and microinches, a description of the resulting surface, and the process by which the surface is produced. When a maximum and minimum limit is specified, the average roughness height must lie within the two limits.

When a standard or general surface finish is specified in the drawing title block or in a general note, a surface finish symbol without roughness height specified is used on all surfaces that are the same as the general specification. When a part is completely finished to a given specification, the general note FINISH ALL OVER, or abbreviation FAO or FAO 125 IN, can be used. The placement of surface finish symbols on a drawing can be accomplished a number of ways as shown in Figure 10.117. Additional elements such as material removal specifications can be applied to the surface finish symbol as shown in Figure 10.118.

## DESIGN AND DRAFTING OF MACHINED FEATURES

You should gain a working knowledge of machining processes and the machining capabilities of the company for which they are used. Drawings should be prepared that allow machining within the capabilities of the machinery available. The first consideration should be the least-expensive method to get the

desired result. Avoid overmachining. Machining processes are expensive, so do not call for requirements on a drawing that are not necessary for the function of the part. For example, as the roughness height decreases, surface finishes become more expensive to machine. If a surface roughness of 125 microinches is adequate, then do not use a 32-microinch specification just because you like smooth surfaces. Another example is demonstrated by the difference between the 63- and 32-microinch finish. A 63-microinch finish is a good machine finish that can be performed using sharp tools at high speeds with extrafine feeds and cuts. The 32-microinch callout requires extremely fine feeds and cuts on a lathe or milling machine and in many cases requires grinding. The 32 finish is more expensive to perform.

In a manufacturing environment in which cost and competition are critical considerations, a great deal of thought must be given to meeting the functional and appearance requirements of a product at the least possible cost. It generally does not take very long for an entry-level drafter to pick up these design considerations by communicating with engineering and manufacturing department personnel. Many drafters become designers, checkers, or engineers within a company by learning the product and being able to implement designs based on manufacturing capabilities.

## TOOL DESIGN

In most production machining operations, special tools are required to either hold the workpiece or guide the machine tool. Tool design involves knowledge of kinematics, which is the study of mechanisms covered in Chapter 16 of this text, machining operations, machine tool function, material handling, and material characteristics. **Tool design** is also known as **jig and fixture design**. In mass-production industries, jigs and fixtures are essential to make sure each part is produced quickly and accurately within the dimensional specifications. These tools are used to hold the workpiece so machining operations are performed in the required positions. Fixture application examples are shown in Figure 10.119. Jigs are either fixed or moving devices used to hold the workpiece in position and guide the cutting tool. Fixtures do not guide the cutting tool but are used in a fixed position to hold the workpiece.

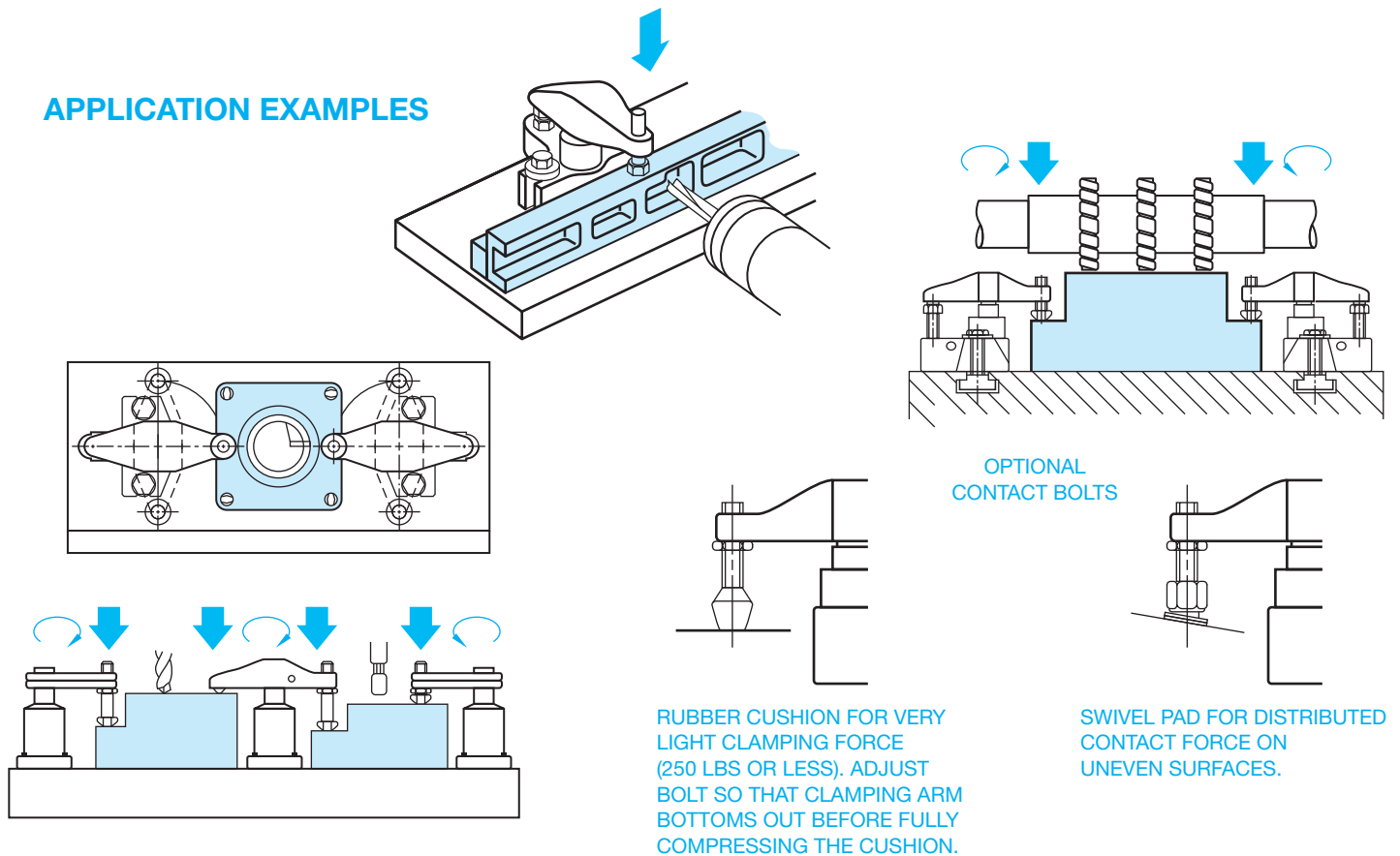


FIGURE 10.119 Fixture application examples. Courtesy Carr Lane Manufacturing Company

Fixtures are often used in the inspection of parts to make sure that the part is held in the same position each time a dimensional or other type of inspection is made.

Jig and fixture drawings are prepared as an assembly drawing where all of the components of the tool are shown as if they are assembled and ready for use, as shown in Figure 10.120. Assembly drawings are discussed in detail in Chapter 15, *Working Drawings*. Components of a jig or fixture often include items such as fast-acting clamps, spring-loaded positioners, clamp straps, quick-release locating pins, handles, knobs, and screw clamps as shown in Figure 10.121. Normally the part or workpiece is drawn in position using phantom lines, in a color such as red, or a combination of phantom lines and color. Non standard components are usually drawn and completely dimensioned on following sheets of the assembly drawing. Standard components are labeled and defined in a parts list or bill of material, which is usually found on the first sheet of the assembly drawing. Assembly drawing and parts lists are described in detail in Chapter 15, *Working Drawings*.

## The Tool Design Process

By Martin Soll

Hammers, pliers, screwdrivers, wrenches, and other related items are tools, but they are not the kind of tools that are created by tool designers. Tools, as referred to in this discussion,

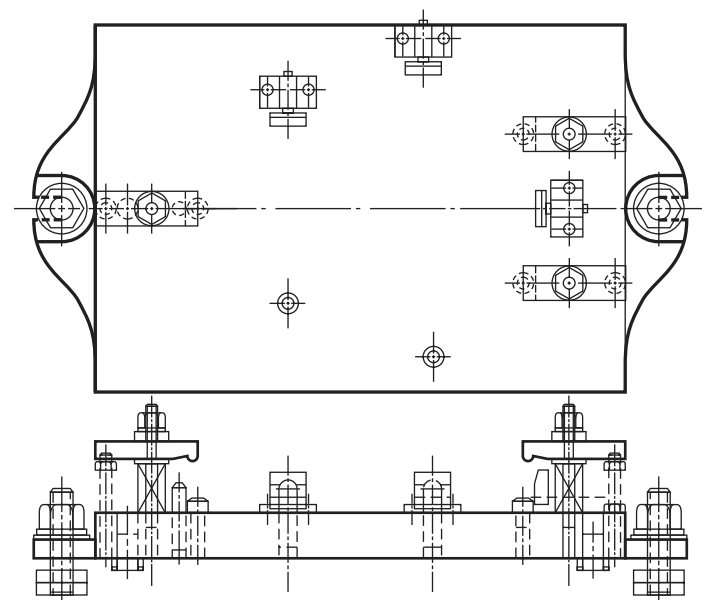


FIGURE 10.120 Fixture assembly drawing. Courtesy Carr Lane Manufacturing Company

are specially designed and built manufacturing aids, normally in production, that are used to assist operators in the manufacture of specific parts. There are many different kinds of tools that fit this definition. These include machining fixtures, welding

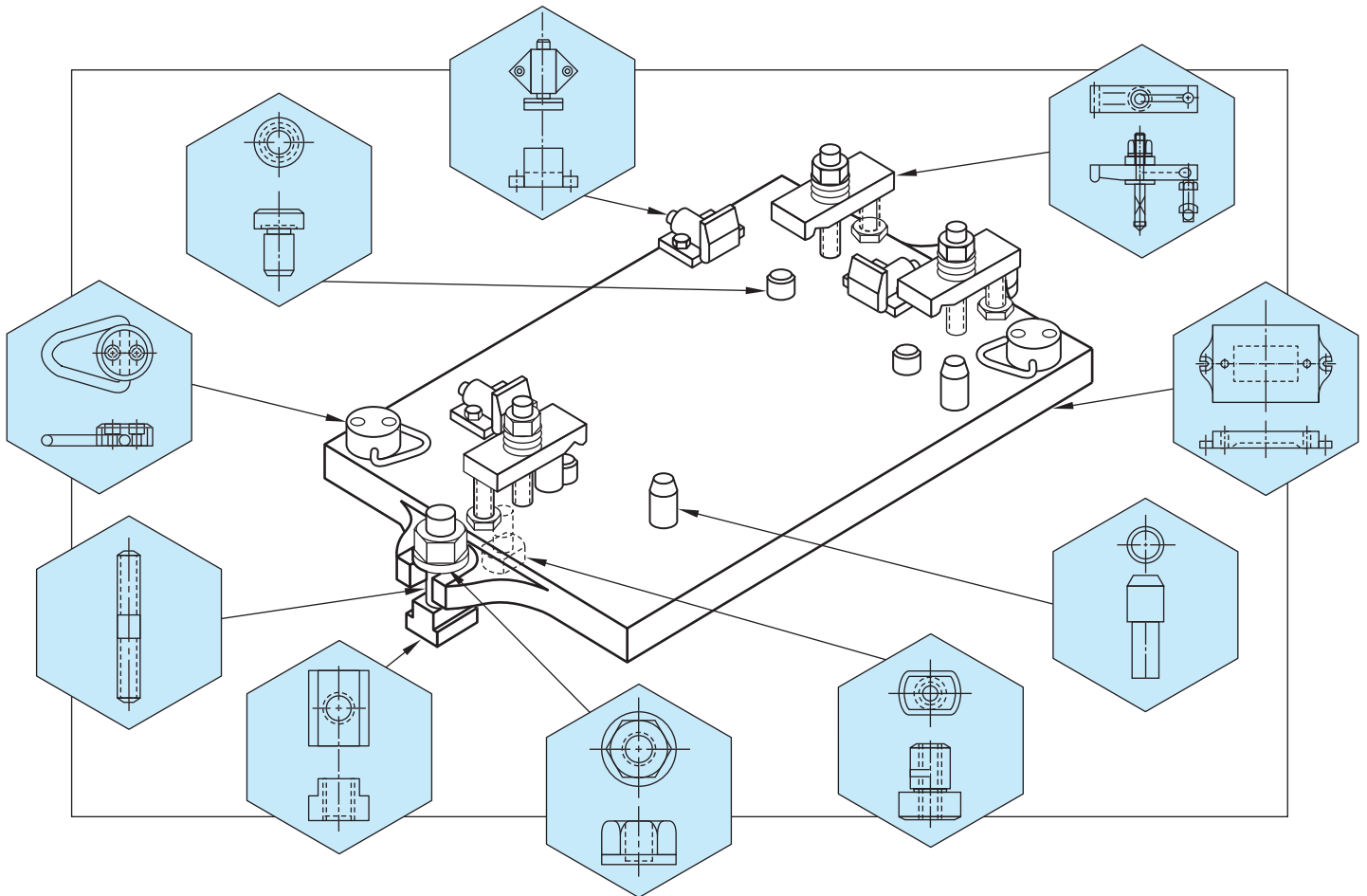
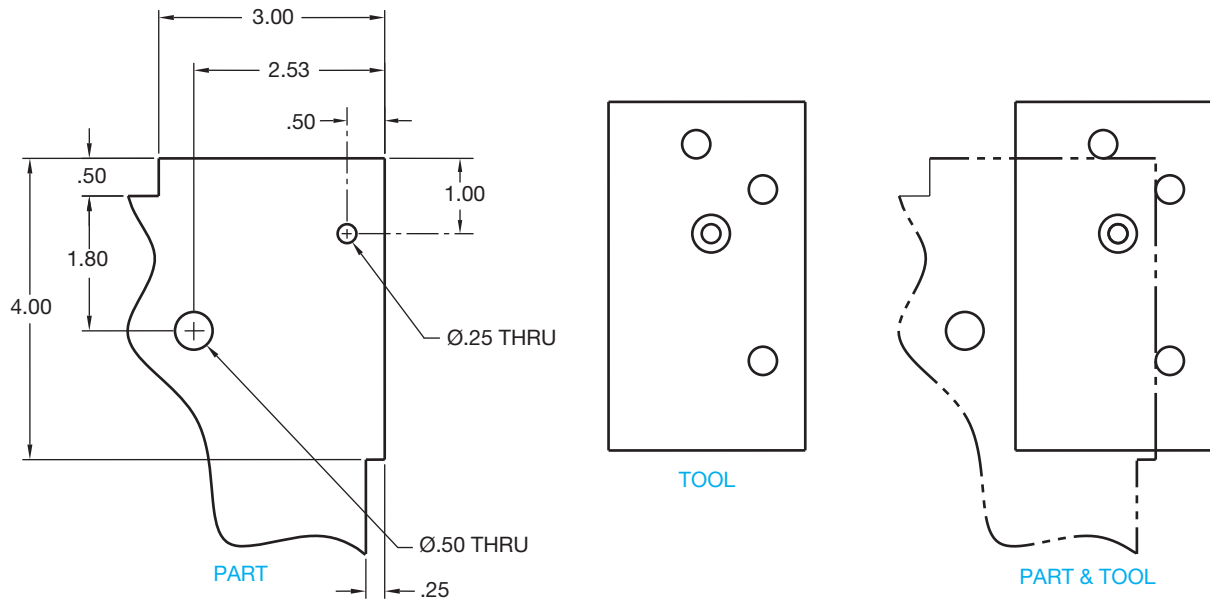


FIGURE 10.121 Fixture components. Courtesy Carr Lane Manufacturing Company

fixtures, drill fixtures, drill jigs, inspection fixtures, progressive dies, injection molds, and many others. Tools can be very small and simple, to very large and complicated. Some tools are mechanisms that resemble machinery, but there is a clear difference between tools and machines. Tools are dedicated to a specific part, family of parts, or product, while machines are for general usage across many parts and products. This differentiation is made more for accounting and tax purposes than it is for technical reasons. Machines are capital investments, while tools are expense items related to a particular part or product. In many cases, the tool is so complex that from a technical perspective, it is a machine, but from an accounting perspective, it is a tool. The following are some very simplified definitions of the typical types of tools used in manufacturing.

- **Drill jigs** are used in drilling operations using hand drills, drill presses, or radial drills, rather than milling machines. The drill jig registers the part relative to the critical datums.
- **Datums** are important points, axes, surfaces, or planes from which features are established and dimensioned. Datums are discussed in detail in Chapter 13, *Geometric Dimensioning and Tolerancing*. The operator then drills through a drill bushing or bushings in the jig, to locate the hole or holes in the part.
- **Drill fixtures** are sometimes referred to as **holding fixtures**. Drill fixtures are used for drilling operations using milling machines, either manual or computer numerical control (CNC). The drill fixture registers the part relative to the critical datums but does not have drill bushings. The machine axes are used to locate the hole or holes. Drill fixtures must resist the force of the drilling operation. Typically, drilling forces are relatively low and are only in one direction.
- **Machining fixtures** are used for machining operations using milling machines that are either manual or CNC. The machining fixture registers the part relative to the critical datums. The machine axes are used to locate the feature or features to be machined. Machining fixtures must resist the force of the machining operation; typically, machining forces are relatively high and can be in any direction.
- **Welding fixtures** are more accurately termed **welding jigs**, but the names have become synonymous in the industry. Welding fixtures are used to hold two or more pieces in the proper position and orientation so the pieces can be welded together, to change orientation to provide for proper welding positions, and to resist shrinkage forces and distortion from heat input.



**FIGURE 10.122** A simple example of a PART and a TOOL. The task of the employee is to drill a .25 in. diameter hole in a specific location. It is very efficient for the employee to use the TOOL to locate the hole. He or she simply places the TOOL on the PART, holds it with one hand, and drills the hole through the PART, using the hole in the TOOL to locate the hole in the PART. Dimension values in this figure are in inches.

- **Inspection fixtures** are very common in the casting industry. They are used to hold a part, registering it on the critical datums, while an inspector checks critical feature sizes, or locations, or both.
- **Progressive dies** are the tooling used in punch-press operations. Continuous stock of relatively thin material is fed into the punch press from coils. As the punch press cycles, the material is cut to appropriate shape, holes are punched, or other operations are performed to make a finished part. Cookie cutters, scissors, and paper hole punches are comparable to progressive dies.

Figure 10.122 shows a very simple drill jig tool. This drill jig is designed and manufactured to assist a shop employee in performing a specific task on a production part. The part is very simple, and the employee could measure and drill the hole without any tool; but for production work, the tool makes the location of the hole much faster, and the accuracy of the hole location is less dependent on the employee's abilities. This type of drill jig is referred to as a **pickoff jig**: *pickoff* because it sits on the part, rather than the part being put into the fixture, and *jig* because it actually locates a feature, which is the .25 in. diameter hole in this example.

Now that you have an idea of what makes up a tool, the following gives you the three basic elements of tool design:

1. Visualizing how shop personnel will accomplish a specific task.
2. Conceptualizing hardware to assist in the accomplishment of that task.
3. Creating drawings so the hardware can be manufactured.

*Visualizing* and *conceptualizing* are not to be confused with inventing. Tool designers are not inventors. In fact, a good tool designer may not consider him- or herself to be creative. Although many tool designers are creative, tool designers use existing products and items whenever possible. Many times, an existing design can be modified to satisfy a new requirement, and good tool designers often save their employer time and money by using existing designs. A tool designer *must* be familiar with shop practices and *must* be able to visualize shop personnel accomplishing specific tasks within the shop environment. This visualization leads to a concept of tools that the shop personnel use to assist in the accomplishment of the task.

The part print contains all the information the tool designer needs. The tool designer must be able to find the important information. Looking back to the example in Figure 10.116, you are shown only a small corner of the part. Even this small corner has much more information than is required for this drill jig. Print reading is the first step in the tool design process. The information necessary to design the drill jig must be found on the part print. Some dimensions are directly related to the drill jig, some are incidental to the tool design, and some are totally unrelated to this drill jig. Looking at Figure 10.116, it is relatively easy to sort out the applicable information. Dimensions defining the feature size and location are directly related to the required tool. Dimensions that define the size and locations of other features that affect the tool are of incidental interest. Dimensions that define the size and locations of features not affecting the design of the tool are not relevant to the tool designer. More complicated part prints require in-depth study to find the relevant information.

Tool designers often receive their assignments from a manufacturing engineer (ME). The ME defines the specific task and how it is to be accomplished. Consider the example in Figure 10.116 again. The tool designer receives a tooling design request (TDR) from the ME. The TDR has an engineering drawing of the part attached and might contain the following information:

- PART NAME: ----- PART
- PART NO: ----- XXXX-XX
- OPERATION:----- DRILL .25 in. DIA HOLE
- MACHINE: ----- USE HAND DRILL
- FIXTURE:----- PICKOFF JIG LOCATING THE HOLE  
.50 in. AND 1.00 in. FROM THE EDGES  
OF THE PLATE

The decision to use a pickoff jig and hand drill rather than a radial drill or even a CNC machine is made prior to the tool designer's involvement in the project. If the ME had determined that the best way to accomplish this task is to put this part on a CNC machine to drill the hole, then the TDR would be written accordingly. The tool designer would design a drill fixture that would be mounted on the CNC machine table. The fixture would hold and clamp the PART. The PART would be located with accurate registration to the two critical edges that define the location of the .25 in. diameter hole.

### The Tool Designer's Tools

A tool designer uses manual drafting or CADD practices to design a fixture. He or she must capture the concept on paper or computer screen in order for the fixture to be built. The tool designer must also be familiar with standard tooling components that are available from numerous manufacturers. Various components, such as rest pads, clamps, pins, and drill bushings, to name a few, are available in a wide variety of sizes and shapes. Remember, tool designers do not create something that already exists, but they use standard components whenever possible.

Tools, in general, must possess some of the following qualities:

- Reliability.
- Repeatability.
- Ease of use.
- Ease of manufacture.
- Ease of maintenance and repair.

In the tool design process, the designer must account for all possible uses and situations that could result in a failure or misuse of the tool. Knowing the use is especially important for material selection in which the choice of material must be based on wear prevention, repeatability, and ergonomics, or where ease of use prevents operator fatigue and errors. In lean manufacturing, the practice of designing against operator or machine errors is commonly called **poka-yoke**, which means **mistake-proofing**. This practice mandates that the design should be such that it simplifies the tool making process and prevents errors by including constraints in the design.

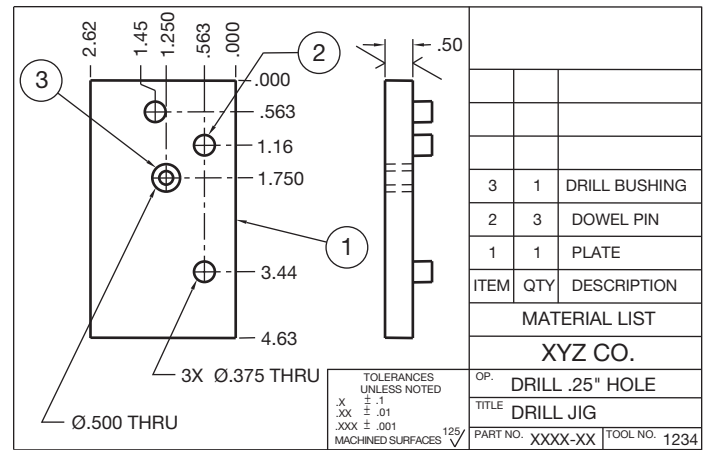


FIGURE 10.123 A basic example of a tool design drawing. © Cengage Learning 2012

Process improvements like **lean manufacturing** and **Six Sigma** are very useful in achieving the qualities listed above. Lean manufacturing is a production practice that eliminates waste in all departments and in all phases from design through manufacturing and to marketing and distribution. Six Sigma is a business management strategy that seeks to improve the quality of process outputs by identifying and removing the causes of defects and minimizing manufacturing variables by using quality management methods, and creates a special network of people within the company who are experts in the use of these methods. Lean manufacturing and Six Sigma are described in detail in Chapter 25, *The Engineering Design Process*. Procedures like checking and testing the design with an operator in the earlier stages of the design can save time and materials in the end.

Figure 10.123 shows the design that would go to the tool room for a machinist to use to build the pickoff drill jig previously discussed and shown in Figure 10.122. The drawing shown is a combination assembly drawing and detail drawing. Fixtures that are more complex require the fixture assembly to be drawn on one sheet and the component details to be drawn on separate sheets. Detail and assembly drawings are covered in Chapter 15, *Working Drawings*.

Notice that the PART in Figure 10.122 is dimensioned using conventional dimension and extension lines, and the DRILL JIG drawing in Figure 10.123 is dimensioned using arrowless dimensioning. Either type of dimensioning practice can be used on both drawings. In addition, note the tolerances of the jig, which should always be held tighter than those of the final part.

The PLATE (Figure 10.123, item 1) is the only piece that must be made in the tool room. The *tool room* is the shop where tools are manufactured. The DOWEL PIN (Figure 10.123, item 2) and the DRILL BUSHING (Figure 10.123, item 3) are purchased components. The following evaluates whether this jig would meet the list of quality requirements for tools.

- **Reliability:** Yes, this jig is simple, and very little could break or cause problems.
- **Repeatability:** Yes, again the simplicity makes repeatability inherent. The drill jig registers directly on the datum surfaces from which the hole location is defined.



## JIG AND FIXTURE DESIGN

CADD jig and fixture design programs make it possible for the designer or engineer to construct the tooling for a specific application electronically. As with other CADD programs, tooling component libraries, consisting of fully detailed and accurate jig and fixture components, are

available in the tool design CADD program or from vendor Web sites. The speed of tooling design can be sharply increased when items such as clamps, locator pins, rests, or fixture bases can be retrieved from the library or online and inserted into your design quickly by using the specific functions provided by the software.

- *Ease of use:* Yes, the jig offers the operator a simple means to locate the hole.
- *Ease of manufacture:* Yes, with only one manufactured part, and four purchased parts, it is very easy to make.
- *Ease of maintenance and repair:* Yes, should something break or wear out, the component parts can be easily replaced.

In summary, you have learned about tools, tool design, and tool designers. Tools are shop aids, sometimes simple and sometimes very complex. Tool design is the process of turning a concept of a tool into drawings so that the fixture can be manufactured. Tool designers are the people who imagine the concepts and turn them into drawings.

## INTRODUCTION TO ISO 9000

The ISO 9000 Quality Systems Standard was established to encourage the development of standards, testing, quality control, and the certification of companies, organizations, and institutions where these practices are implemented. ISO stands for the **International Organization for Standardization**. The ISO is an international organization made up of nearly 100 countries. The United States is a member country that is represented by the American National Standards Institute (ANSI). ISO 9000 can certify companies, organizations, and institutions when their engineering, drafting standards, manufacturing, and quality control meet the requirements of a model quality-management system established by the ISO 9000 organization. A certification is obtained by passing an inspection by an independent representative of the ISO. ISO 9000 certification is also referred to as *registration*. There are a number of reasons why a company may want to become ISO 9000 certified. The reasons can include:

- In order to do business with customers that require ISO 9000 certification. This includes agencies of the U.S. government.

- To compete in a competitive market that requires strict attention to quality control.
- To lower cost and improve profits.
- To improve and maintain customer confidence.
- A desire to improve product quality and place emphasis on customer relations.
- To manufacture and sell products in the European Union markets where this certification is required.
- To require that subcontractors meet the same expectations for quality control.
- The ISO 9000 certification also satisfies requirements established by other local and national organizations.
- To improve company standards.

The ISO 9000 Quality Systems Standard is made up of a series of five international standards that provide leadership in the development and completion of a successful quality management system. These five standards are briefly described as follows:

- ISO 9000-1 provides direction and definitions that describe what each standard contains and assists companies in the selection and use of the appropriate ISO standard for the desired results.
- ISO 9001 is the model that can be used by any organization for designing, documenting, and implementing ISO standards. The model takes a product through the process of design, drafting, manufacturing, quality control, installation, and service.
- ISO 9002 is the same as ISO 9001, except that it does not contain the requirement of documenting the design and development process.
- ISO 9003 is for companies or organizations that only need to demonstrate through inspection and testing methods that they are providing the desired product or service.

- ISO 9004-1 is a set of guidelines that can be used to assist organizations in the development and implementation of a quality management system.

In addition to the ISO 9000 series are the QS 9000 and AS 9000 standards. The QS 9000 is the Automotive Requirements,

and the AS 9000 is the Aerospace Standard. These standards contain all of ISO 9001 plus requirements beyond ISO 9001. These standards were developed by the U.S. automotive and aerospace industries for specific applications and needs that customize the standard for their industries.

## PROFESSIONAL PERSPECTIVE

The proper placement and use of dimensions is one of the most difficult aspects of drafting. It requires careful thought and planning. First, you must determine the type of dimension that fits the application and then correctly place the dimension on the drawing. Although the CADD system makes the actual placement of dimensions quick and easy, it does not make the planning process any easier. Making preliminary sketches is very important before beginning a drawing. The preliminary sketch allows you to select and place the views and then place the dimensions.

One of the big issues an entry-level drafter faces is determining which dimensions are important and where the dimensions should be placed. In many cases, dimensioning requirements are underestimated. In addition, try to avoid creating a drawing that is crowded with dimensions. As a rule of thumb, if you think the drawing is crowded on a particular size sheet, then play it safe and use the next larger size sheet to help reduce crowding. Most companies want the drawing information spread out and easy to read, but some companies want the drawing crowded with as much information as you can get on a sheet. This text supports a clean and easy-to-read drawing that is not crowded. Out on the job, however, you must do what is required by your employer. If you are creating an uncrowded drawing, you should consider leaving about one-quarter of the drawing space clear of view and dimensional information. Usually this space is above and to the left of the title block. This clear space provides adequate room for general notes and engineering changes. Engineering changes are covered in Chapter 15, *Working Drawings*.

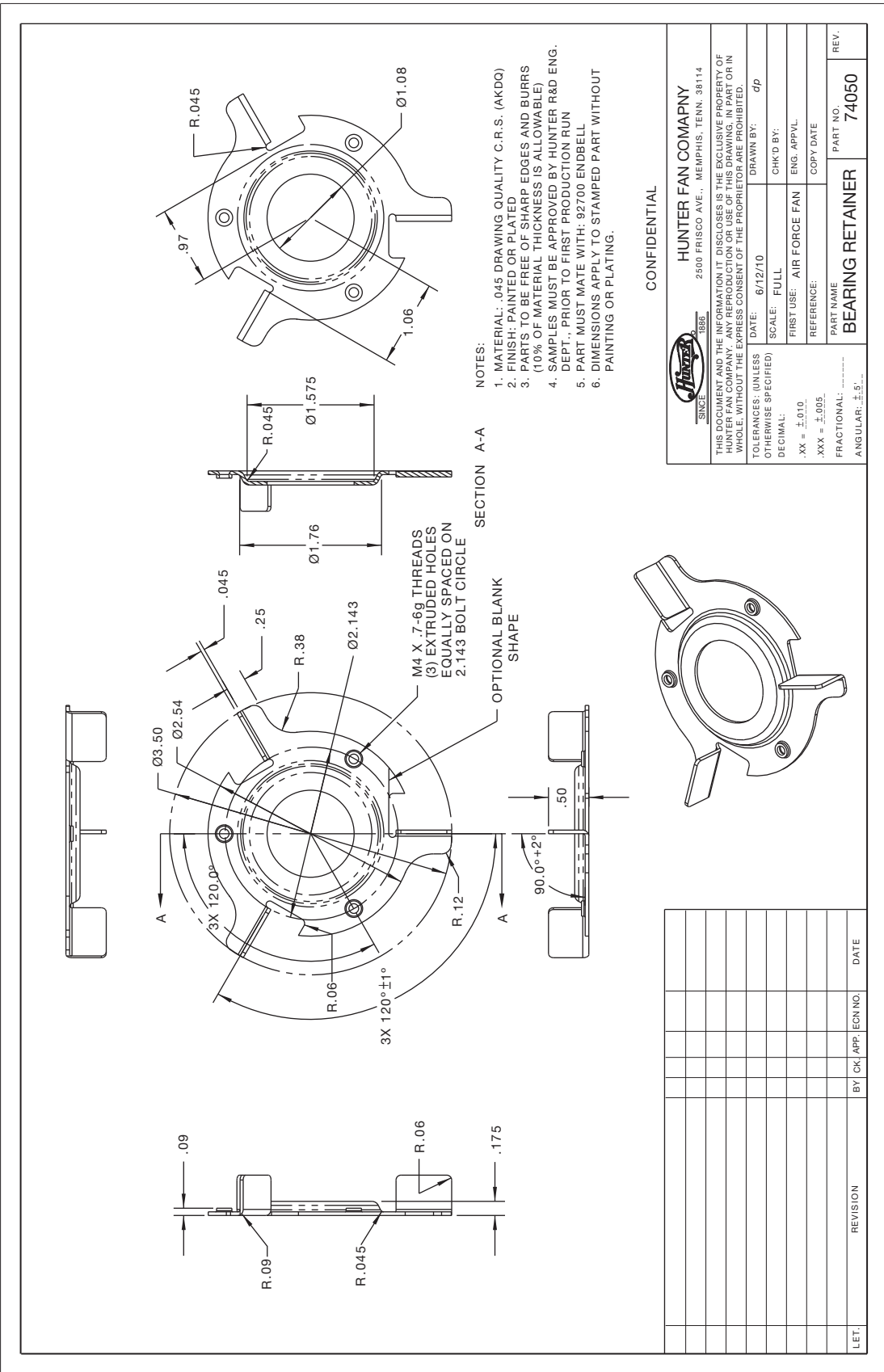
Follow the dimensioning rules, guidelines, and examples discussed in this chapter and use proper dimensioning standards. Try hard to avoid breaking dimensioning standards. The following are some of the pitfalls to watch out for when placing dimensions as a beginning drafter.

- Do not crowd dimensions. Keep your dimension line spacing equal and far enough apart to separate the dimension numerals clearly.
- Do not dimension to hidden features. This also means do not dimension to the centerline of a hole in the hidden view. Always dimension to the view where the feature appears as a visible object line.

- Dimension to the view that shows the most characteristic shape of an object or feature. For example, dimension shapes where you see the contour, dimension holes to the circular view, and dimension cylindrical shapes in the rectangular view.
- Do not stack adjacent dimension numerals. Stagger dimension numerals so they are easier to read.
- Group dimensions as much as you can. It is better to keep dimensions concentrated to one location or one side of a feature rather than spread around the drawing. This makes the drawing easier to read.
- Create a standard symbol library or use software with symbols available. Symbols speed up the drafting process, and they clearly identify the feature. For example, if you draw a single view of a cylinder, the diameter  $\varnothing$  dimension is identified in the rectangular view and drawing the circular view may not be necessary. Most CADD programs automatically recognize a diameter dimension and properly place the symbol, but you may need to create some symbols.
- Look carefully at the figures in this text and use them as examples as you prepare your drawings.

Try to put yourself in the place of the person who has to read and interpret your drawing. Make the drawing as easy to understand as possible. Keep the drawing as uncluttered and as simple as possible yet still complete. Figure 10.124 shows an industry drawing of a complex part. Notice how the drafter carefully selected views and dimension placement to make the drawing as easy to read as possible.

Now go back to the beginning of this chapter and read the Engineering Design Application segment again. The steps used to lay out a dimensioned multiview drawing were presented to give you a general idea about the process a drafter goes through when converting an engineering sketch into a formal drawing. Read the steps again and look at Figures 10.1 through 10.6. This review, along with spending some time looking at the complex actual industry drawing in Figure 10.124, will help you pull together the dimensioning basics that you learned throughout this chapter.



Courtesy Hunter Fan Company

**FIGURE 10.124** A complex drawing with dimensions placed in the proper locations to aid in reading the drawing. Notice the pictorial drawing in the bottom center. This is shown to help you visualize the part. Dimension values in this figure are in inches.

### DIMENSIONING FOR CADD/CAM

The implementation of CADD and computer-aided manufacturing (CAM) in industry is best accomplished when common control of the computer exists between engineering and manufacturing. The success of this automation is, in part, relative to the standardization of operating and documentation procedures. CADD can be accomplished through the same coordinate dimensioning systems previously described in this chapter. Standard dimensioning systems are used to establish a geometric model of the part, which in turn is displayed at a CADD workstation. The data retrieved from this model is the mathematical description of the part to be produced. The drafter must dimension the part completely and accurately so that each contour or geometric shape of the part is continuous. The dimensioning systems that locate features or points on a feature in relation to X, Y, and Z axes derived from a common origin are most effective, such as datum, tabular, arrowless, and polar coordinate dimensioning. The X, Y, and Z axes originate from three mutually perpendicular planes that are generally the geometric counterpart of the sides of the part when the surfaces are at right angles as seen in Figure 10.125. If the part is cylindrical, two of the planes intersect at right angles to establish the axis of the cylinder and the third is perpendicular to the intersecting planes as shown in Figure 10.126. The X, Y, and Z coordinates that are used to establish features on a drawing are converted to X, Y, and Z axes that correspond to the linear and rotary motions that occur in CAM.

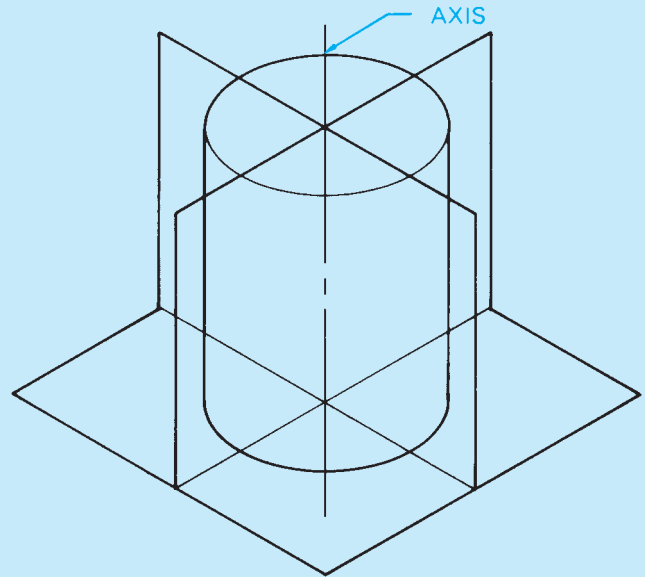


FIGURE 10.126 The planes related to the axis of a cylindrical feature. © Cengage Learning 2012

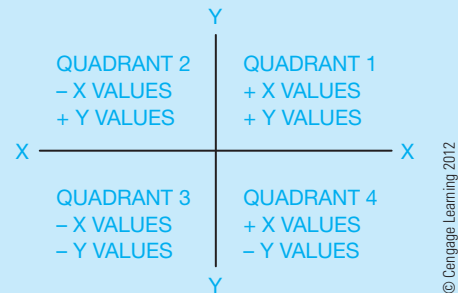


FIGURE 10.127 Determination of X and Y values in related quadrants.

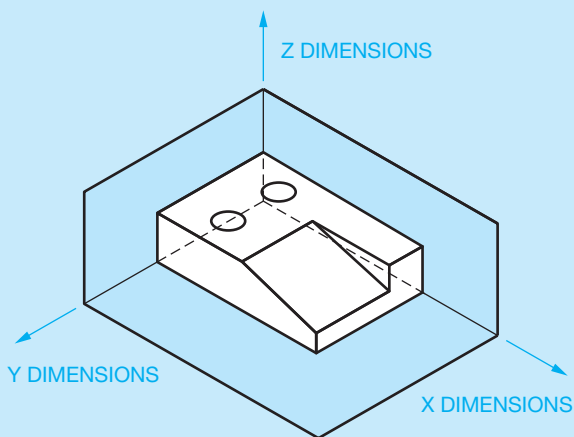
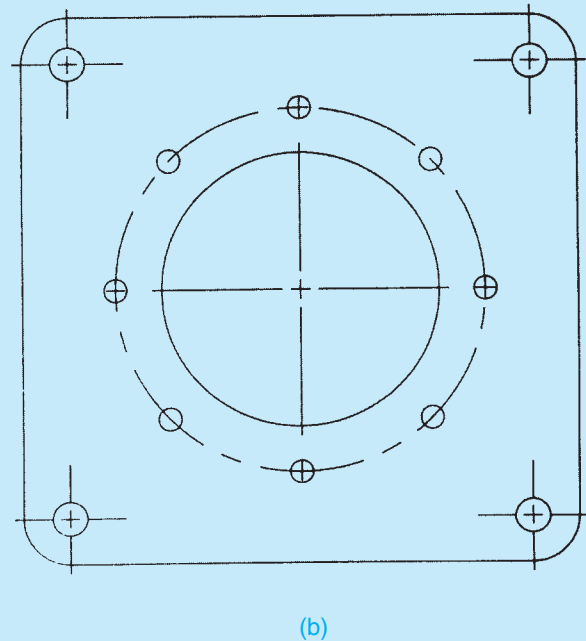
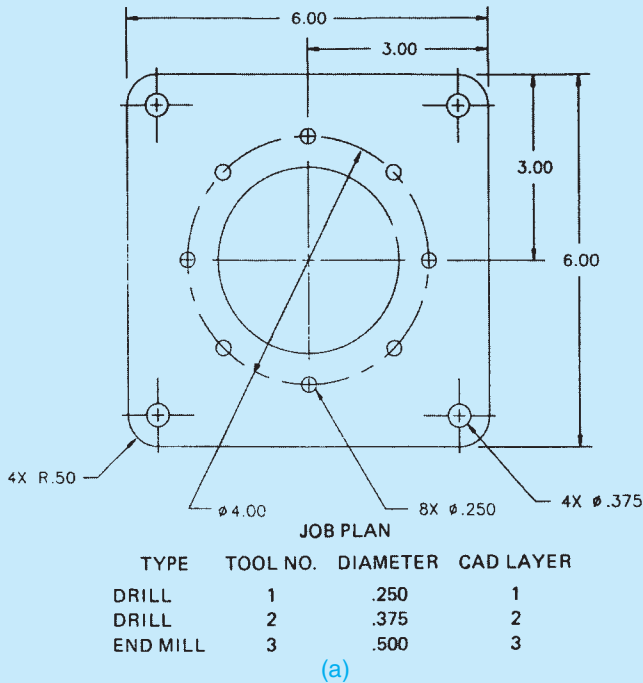


FIGURE 10.125 Features of a part dimensioned in relation to X, Y, and Z axes.

The position of the part in relation to mathematical quadrants determines whether the X, Y, and Z values are positive or negative. The preferred position is the mathematical quadrant that allows for programming positive commands for the machine tool. Notice in Figure 10.127 that the positive X and Y values occur in quadrant 1.

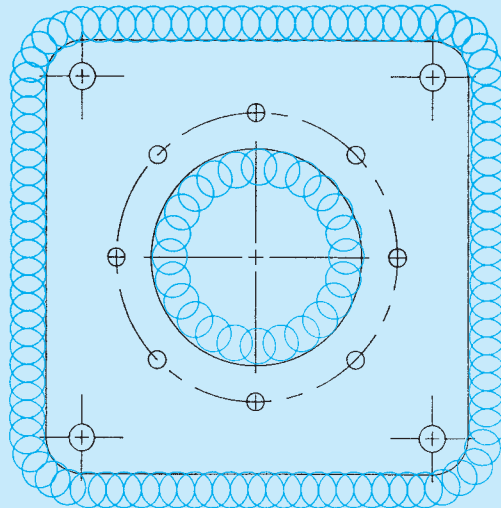
In CAD/CAM and computer-integrated manufacturing (CIM) programs, the drawing is made on the computer screen and sent directly to the computer numerical control machine tool without generating a hard copy of the drawing. In this situation, it becomes important for the drafter to understand the machine tool operation. Figure 10.128a shows a drawing created for CAD/CAM,

(Continued)



**FIGURE 10.128** A drawing created for CAD/CAM. Dimension values in this figure are in inches. (b) Drawing from (a) represented on the computer screen prior to generating the machine tool program. © Cengage Learning 2012

and Figure 10.128b shows the same drawing as represented on the computer screen prior to generating the machine tool program. Notice the dimensions are not displayed on the drawing in Figure 10.128b. The data used to input the information from the original design drawing is used by the computer to establish the machine tool paths. The CAD/CAM program also allows the operator to show the tool path, as shown in Figure 10.129. The tool path display allows the operator to determine if the machine tool will perform the assigned machining operation.



**FIGURE 10.129** The tool path display, shown in color, allows the operator to determine if the machine tool will perform the assigned machining operations. Dimension values in this figure are in inches.

## RECOMMENDED REVIEW

It is recommended that you review the following parts of Chapter 6 before you begin working on fully dimensioned multiview drawings. This will refresh your memory about how related lines are properly drawn.

- Object lines.
- Extension lines.
- Viewing planes.
- Hidden lines.

- Break lines.
- Dimension lines.
- Centerlines.
- Phantom lines.
- Leader lines.
- Lettering standards and practices.

In addition, review Chapters 8 and 9, covering multiview and auxiliary view drawings, and Chapter 4, discussing manufacturing materials and processes.

### FINDING DIAGONALS

Suppose you need the distance from one point on a drawing to another, such as between points A and B in Figure 10.130.

#### SOLUTION

Sides: height (h) = 5, width (w) = 13

$$\text{Diagonal (d)} = \sqrt{h^2 + w^2}$$

$$d = 13.9$$

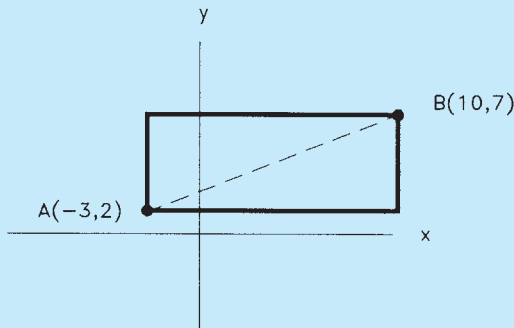


FIGURE 10.130 Finding the diagonal of a rectangle.

© Cengage Learning 2012

Find the distance from C to D in Figure 10.131.

#### SOLUTION

Sides: height (h) = 2, width (w) = 2

length (L) = 3

$$\text{Diagonal (d)} = \sqrt{h^2 + w^2 + L^2}$$

$$d = 4.12$$

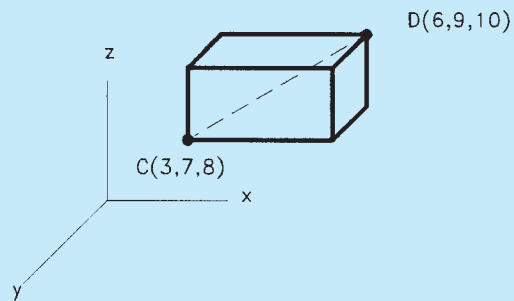


FIGURE 10.131 Finding the diagonal of a cube.

© Cengage Learning 2012

### WEB SITE RESEARCH

Use the following Web sites as a resource to help find more information related to engineering drawing and design and the content of this chapter.

Address	Company, Product, or Service
www.adda.org	American Design Drafting Association and American Digital Design Association (ADDA International)
www.amazon.com	Search Books for <i>AutoCAD and Its Applications</i>
www.ansi.org	American National Standards Institute (ANSI)
www.asme.org	American Society of Mechanical Engineers (ASME)
www.globalspec.com	The Engineering Web makes it faster and easier for you to research topics, products, and services by limiting your search to technical and engineering-related Web sites.
www.g-w.com	Select <b>Technical and Trades Technology</b> , followed by <b>CAD/Animation/Drafting</b> , and look for the latest, or your desired, edition of <i>AutoCAD and Its Applications, Basic</i> . This provides in-depth coverage on the use of AutoCAD to create dimensions based on ASME and other accepted standards.
www.industrialpress.com	Information about the <i>Machinery's Handbook</i> . This is a valuable resource for manufacturing standards, sizes, tolerances, fits, materials, and anything else you can think of for design and drafting.
www.industrialpress.com	On line trigonometry tables
www.iso.org	International Organization for Standardization

## Chapter 10 Dimensioning and Tolerancing Test



To access the Chapter 10 test, go to the Student CD, select **Chapter Tests and Problems**, and then **Chapter 10**. Answer the questions

with short, complete statements, sketches, or drawings as needed. Confirm the preferred submittal process with your instructor.

## Chapter 10 Dimensioning and Tolerancing Problems

### Problems Continued from Previous Chapters

In addition to the problems found in this chapter, you can go back to the following previous chapters and complete the drawings by adding the given dimensions. Open the existing drawing and edit views by moving to accommodate dimension placement.

- Chapter 6 Lines and Lettering: Problems 6.1 through 6.11.
- Chapter 7 Drafting Geometry: Problems 7.21 through 7.43.
- Chapter 8 Multiviews: Problems 8.58 through 8.89.
- Chapter 9 Auxiliary Views: Problems 9.15 through 9.37.

## INSTRUCTIONS

- From the selected sketch, determine which view should be the front view. Then determine which other views, if any, you need to draw to fully display the part in a multiview drawing.
- Make a multiview sketch of the selected problem as close to correct proportions as possible. Be sure to indicate where you intend to place the dimension lines, extension lines, arrowheads, and hidden features to help you determine the spacing for your final drawing.
- Using the sketch you have just developed as a guide, make an original multiview drawing on an adequate size drawing sheet and at an appropriate scale. Include all dimensions needed using unidirectional dimensioning. From the selected problems, determine which views and dimensions should be used to completely detail the part.
- Include the following general notes at the lower-left corner of the sheet .5 in. each way from the corner border lines:

### NOTES:

- DIMENSIONING AND TOLERANCING PER ASME Y14.5-2009.
- REMOVE ALL BURRS AND SHARP EDGES.

Additional general notes may be required, depending on the specifications of each individual assignment. Use the following for tolerances for unspecified inch values. A tolerance block is recommended as described in Chapter 2.

### UNSPECIFIED TOLERANCES

DECIMALS	IN
X	$\pm .1$
XX	$\pm .01$
XXX	$\pm .005$
ANGULAR	$\pm 30'$
FINISH	125 $\mu\text{in.}$

For metric drawings, provide a general note that states: TOLERANCES FOR UNSPECIFIED DIMENSIONS COMPLY WITH ISO 2768-m. Provide a general note that states: SURFACE FINISH 3.2  $\mu\text{m}$  UNLESS OTHERWISE SPECIFIED.

Each problem assignment is given as an engineer's layout to help simulate actual drafting conditions. Initial problems provide a suggested layout and problems become more complex as you continue.

Dimensions and views on engineers' layouts may not be placed in accordance with acceptable standards. You need to carefully review the chapter material when preparing the layout sketch. In some problems, the engineer's layout *assumes* certain information, such as the symmetry of a part or the alignment of holes. You need to place enough dimensions or draw lines between features to *fully* dimension the part.



### Drafting Templates

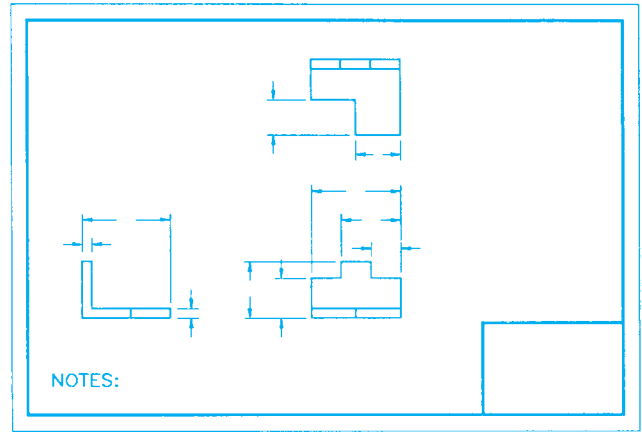
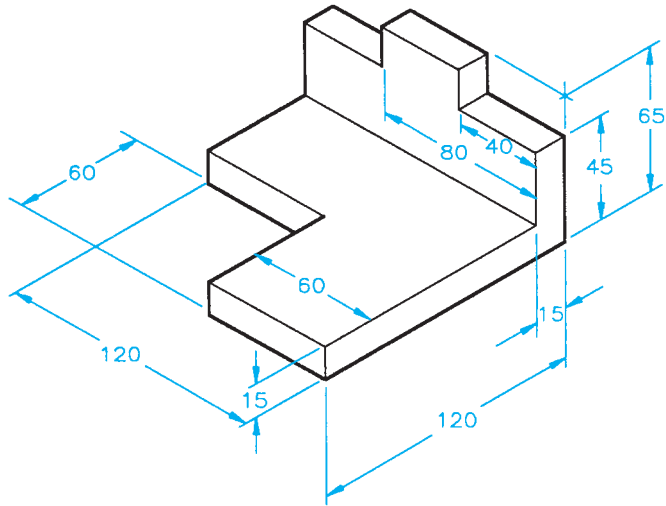
To access CADD template files with predefined drafting settings, go to the Student CD, select **Drafting Templates**, and then select the appropriate template file. Use the templates to create new designs, as a resource for drawing and model content, or for inspiration when developing your own templates. The ASME-Inch and ASME-Metric drafting templates follow ASME, ISO, and related mechanical drafting standards. Drawing templates include standard sheet sizes and formats, and a variety of appropriate drawing settings and content. You can also use a utility such as the AutoCAD DesignCenter to add content from the drawing templates to your own drawings and templates. Consult with your instructor to determine which template drawing and drawing content to use.

Part 1: Problems 10.1 Through 10.20

PROBLEM 10.1 Basic practice (metric)

Part Name: Step

Block Material: SAE 1020



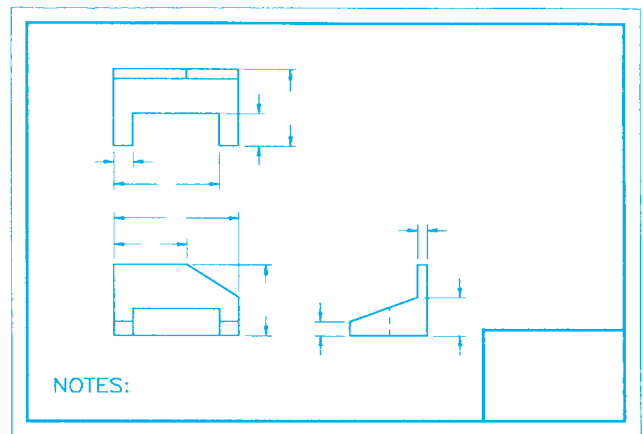
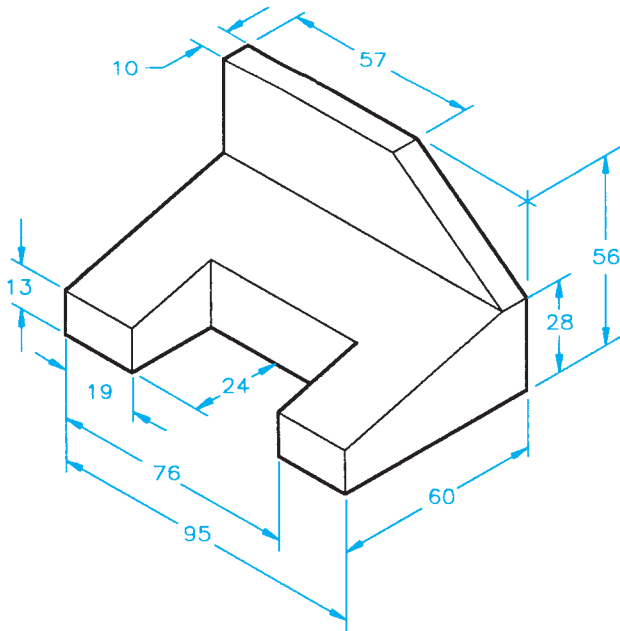
LAYOUT SKETCH STARTED

© Cengage Learning 2012

PROBLEM 10.2 Basic practice (metric)

Part Name: Machine Tool Wedge

Plate Material: SAE 4320



LAYOUT SKETCH STARTED

© Cengage Learning 2012

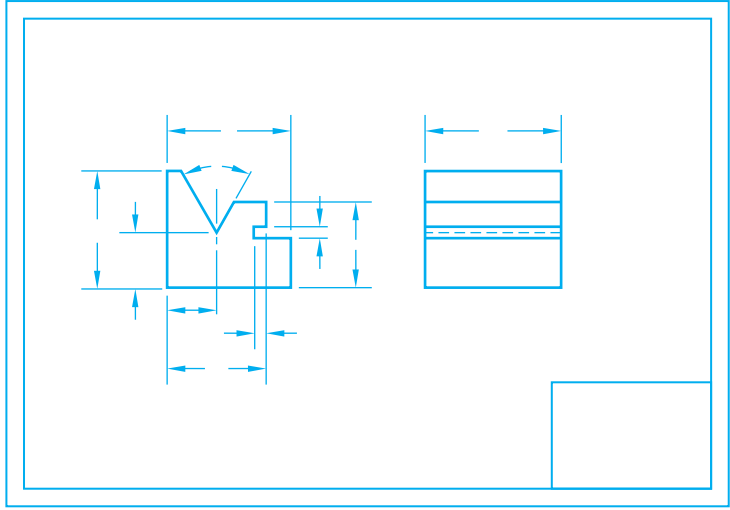
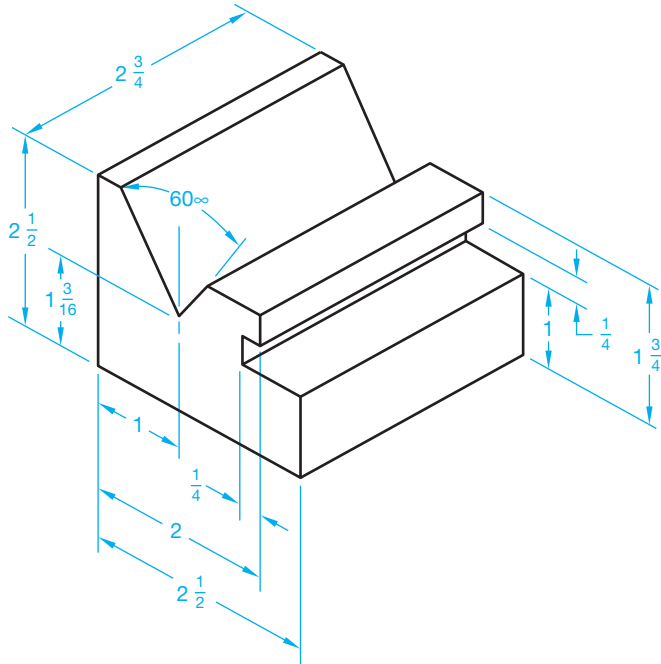


**PROBLEM 10.3** Dimensioning basic practice (in.)

Part Name: V-guide

Material: SAE 4320

Fractions:  $\pm 1/32$



LAYOUT SKETCH  
OPTIONAL SINGLE VIEW WITH LENGTH  
GIVEN IN GENERAL NOTE OR TITLE BLOCK

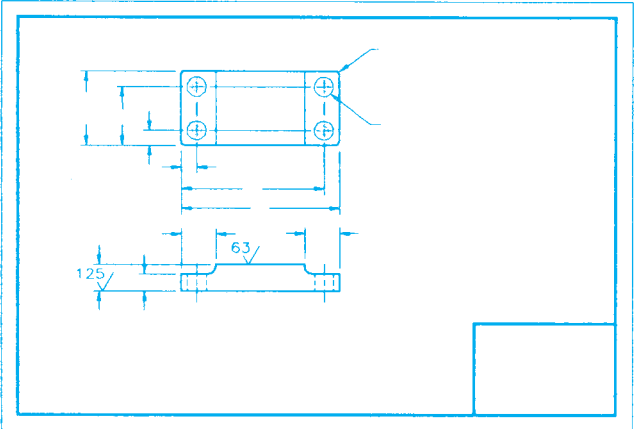
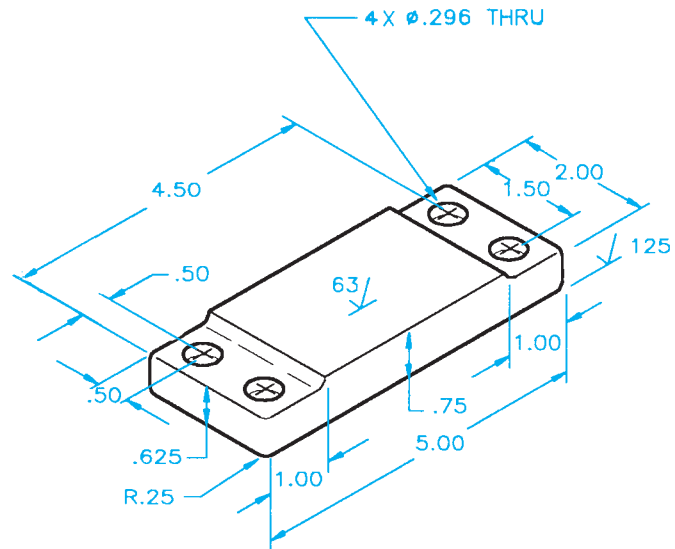
© Cengage Learning 2012

**PROBLEM 10.4** Circles and arcs. (in.)

Part Name: Rest Pad

Material: SAE 1040

Fillets: R.125

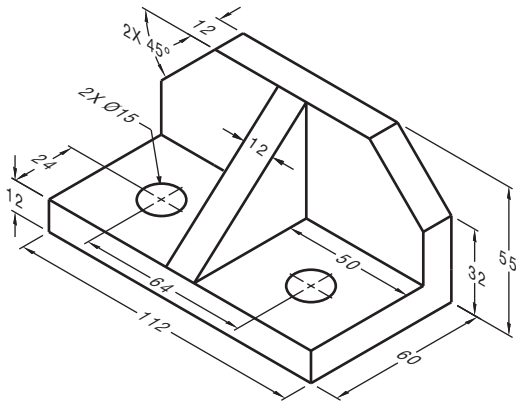


LAYOUT SKETCH

© Cengage Learning 2012

**PROBLEM 10.5 Limited space (metric)**

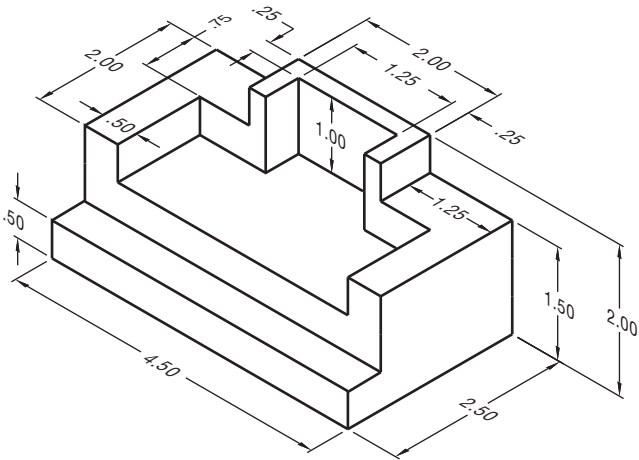
Part Name: Angle Bracket  
 Material: Mild Steel (MS)



© Cengage Learning 2012

**PROBLEM 10.6 Dimensioning contours and limited spaces (in.)**

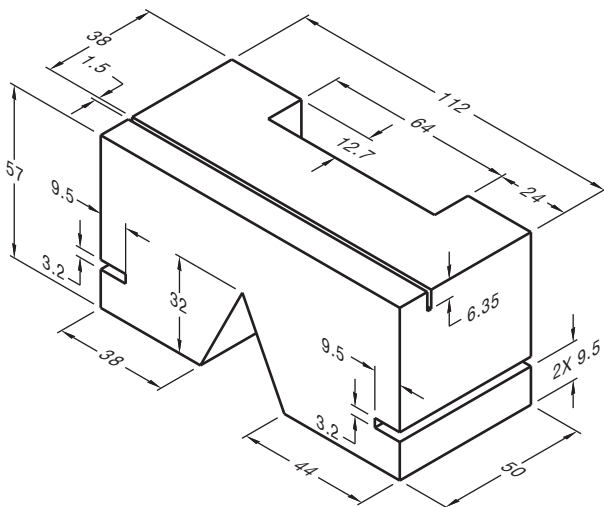
Part Name: Support  
 Material: Aluminum



© Cengage Learning 2012

**PROBLEM 10.7 Limited spaces (metric)**

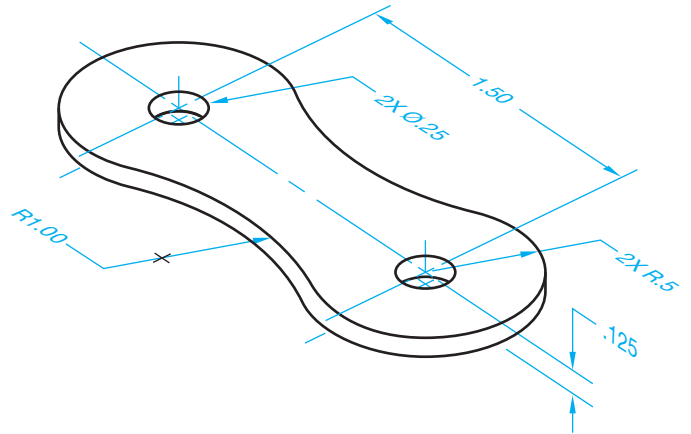
Part Name: Selector Slide Kicker  
 Material: Aluminum 1510



© Cengage Learning 2012

**PROBLEM 10.8 Circles and arcs (in.)**

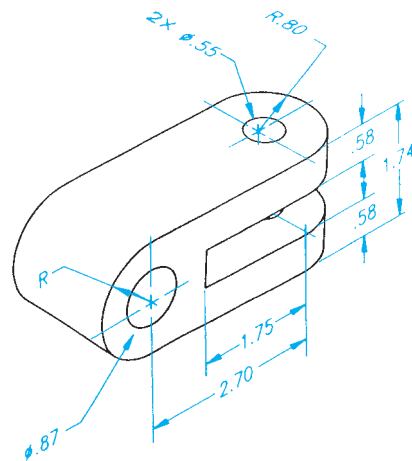
Part Name: Chain Link  
 Material: SAE 4320



© Cengage Learning 2012

**PROBLEM 10.9 Holes and limited space (in.)**

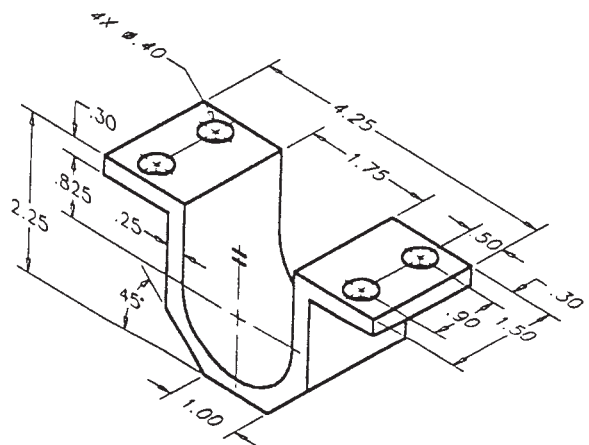
Part Name: Pivot Bracket  
 Material: SAE 1040



© Cengage Learning 2012

**PROBLEM 10.10 Holes, angles, and arcs (in.)**

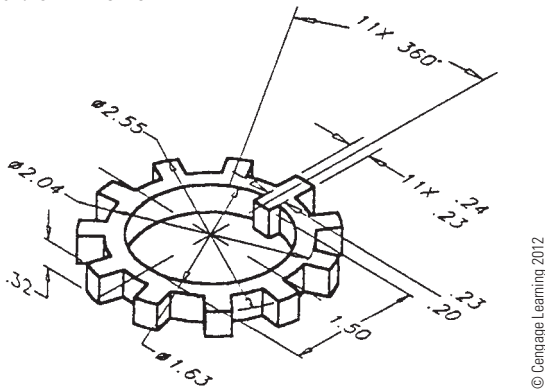
Part Name: Journal Bracket  
 Material: Cast iron (CI)



© Cengage Learning 2012

**PROBLEM 10.11 Dimensioning multiple features (in.)**

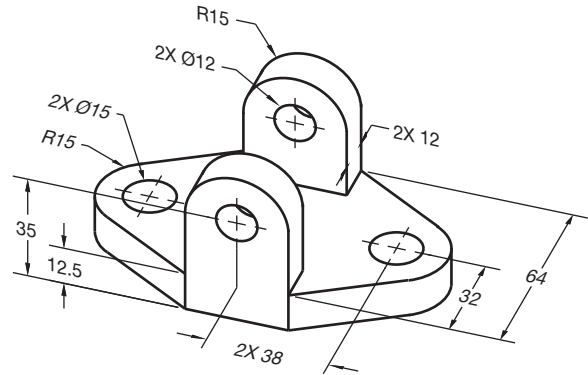
Part Name: Lock Ring  
Material: SAE 1020



© Cengage Learning 2012

**PROBLEM 10.14 Circles and arcs (metric)**

Part Name: Hinge  
Bracket Material: Cast aluminum

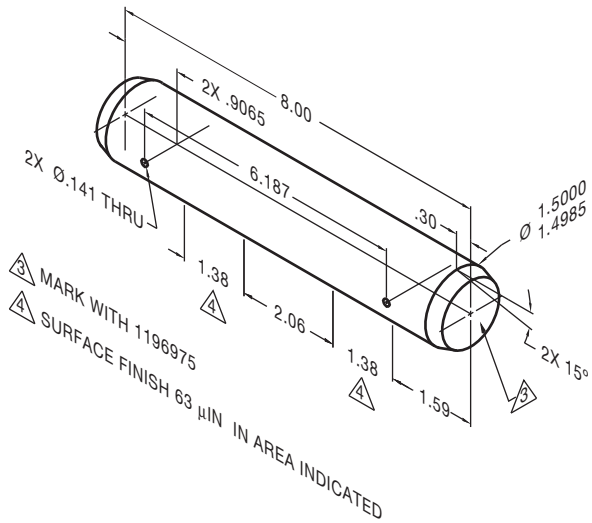


© Cengage Learning 2012

**PROBLEM 10.12 Single view (in.)**

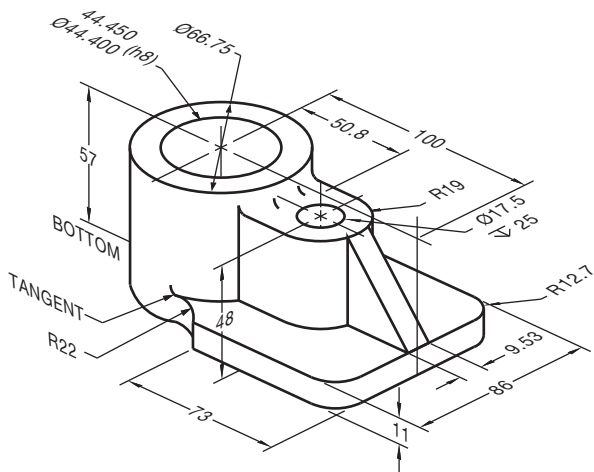
Part Name: Idler Gear Shaft  
Material: MIL-S-7720

Problem based on original art courtesy of Aerojet TechSystems Company



**PROBLEM 10.13 Circles and arcs (metric)**

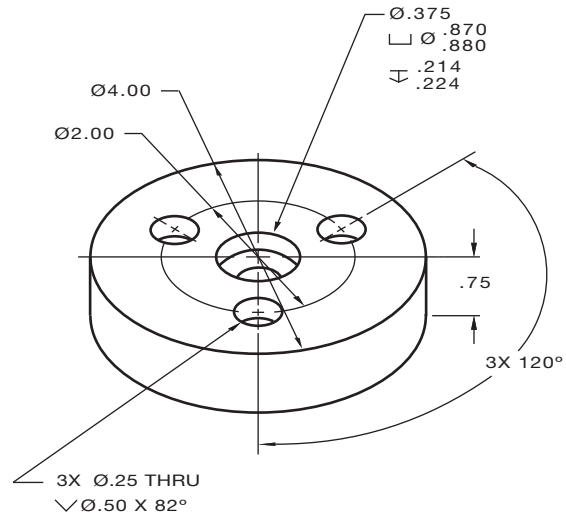
Part Name: Bearing Support  
Material: SAE 1040  
Fillet: R6



© Cengage Learning 2012

**PROBLEM 10.15 Machine features (in.)**

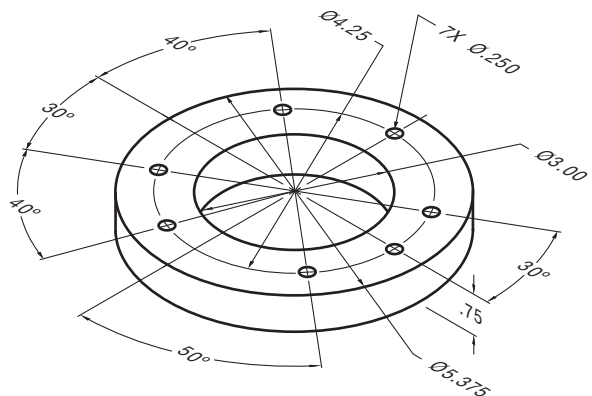
Part Name: Spacer  
Material: SAE 1030



© Cengage Learning 2012

**PROBLEM 10.16 Polar coordinate dimensioning (in.)**

Part Name: Spacer  
Material: Plastic



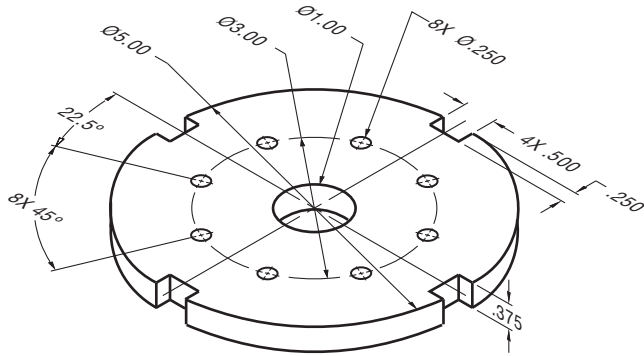
© Cengage Learning 2012

**PROBLEM 10.17 Repetitive features (in.)**

Part Name: Slot Plate

Material: Aluminum

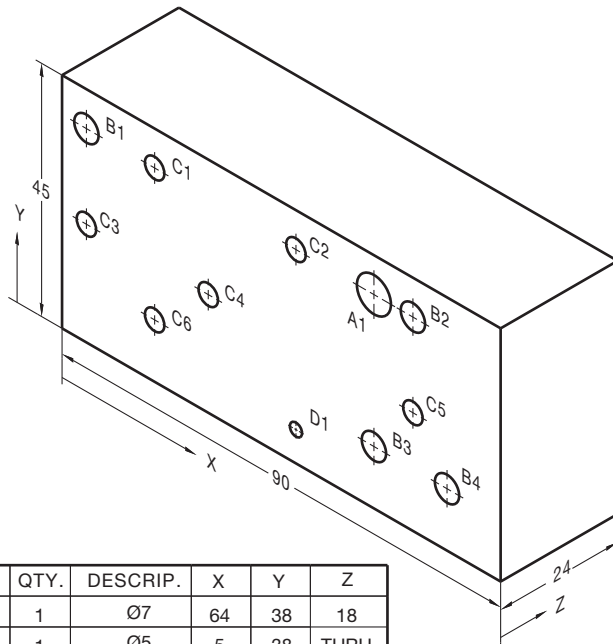
SPECIFIC INSTRUCTIONS: Using the RC4 standard tolerance limits found in Figure 10.81, the Appendices, or the *Machinery's Handbook*, calculate and apply limits values to the 1.00 dimension.



**PROBLEM 10.18 Tabular dimensioning (metric)**

Part Name: Mounting Base

Material: Stainless steel



HOLE	QTY.	DESCRIP.	X	Y	Z
A1	1	Ø7	64	38	18
B1	1	Ø5	5	38	THRU
B2	1	Ø5	72	38	THRU
B3	1	Ø5	64	11	THRU
B4	1	Ø5	79	11	THRU
C1	1	Ø4	19	38	THRU
C2	1	Ø4	48	38	THRU
C3	1	Ø4	5	21	THRU
C4	1	Ø4	30	21	THRU
C5	1	Ø4	72	21	THRU
C6	1	Ø4	19	11	THRU
D1	1	Ø2.5	48	6	THRU

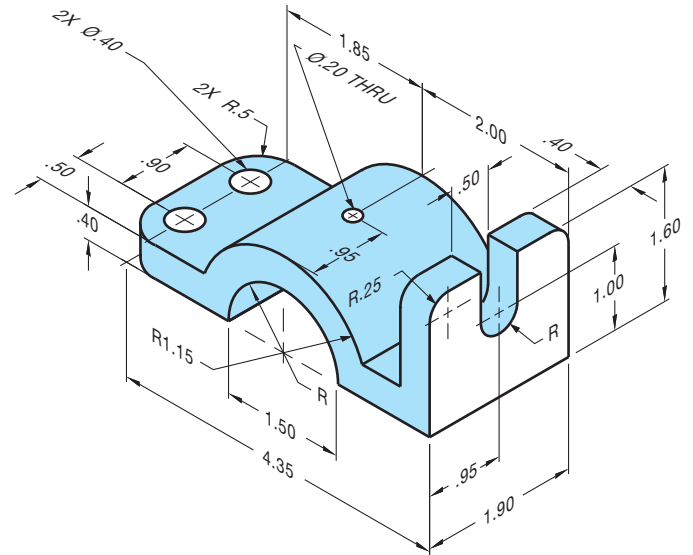
© Cengage Learning 2012

**PROBLEM 10.19 Dimensioning circles, arcs, and slots (in.)**

Part Name: Top Pipe Support Bracket

Material: SAE 1020

Fillets: R12



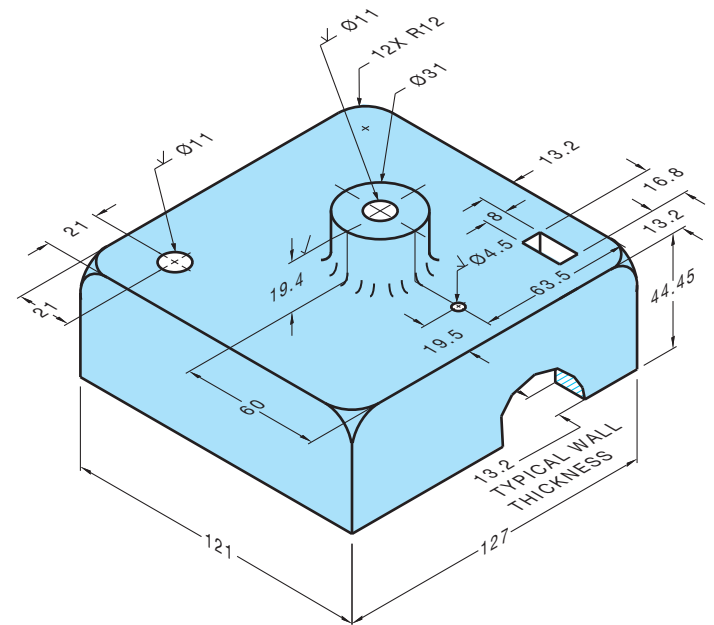
© Cengage Learning 2012

**PROBLEM 10.20 Chain dimensioning (metric)**

Part Name: Control Housing Cover

Material: Cast iron

Do not draw a sectional view. Sections are covered in Chapter 12. Consider a bottom view to show wall thickness.



© Cengage Learning 2012

Part 2: Problems 10.21 Through 10.32

To access the Chapter 10 problems, go to the Student CD, select **Chapter Tests and Problems** and **Chapter 10**, and then open the problem of your choice or as assigned by your instructor. Solve the problems using the instructions provided on the CD, unless otherwise specified by your instructor.

Part 3: Problems 10.33 Through 10.35

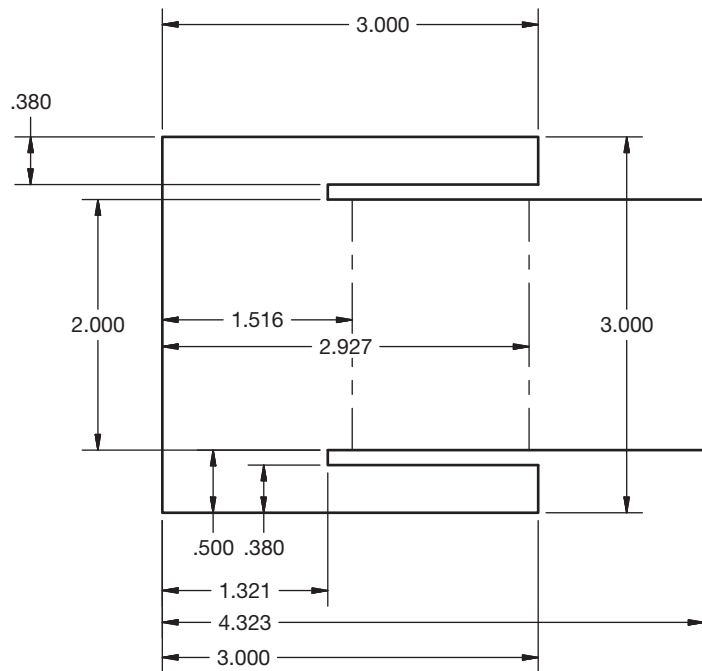
Use the same instructions provided at the beginning of the problems for this chapter, using an appropriately sized sheet, border, and sheet block for each problem.

**PROBLEM 10.33 Correct ASME errors (in.)**

Part Name: Electronics Divider

Material: .125 in. THICK, Acrylonitrile-butadiene-styrene (ABS)

The given drawing has intentional ASME dimensioning errors. Redraw the part using correct ASME dimensioning standards as described throughout this chapter.

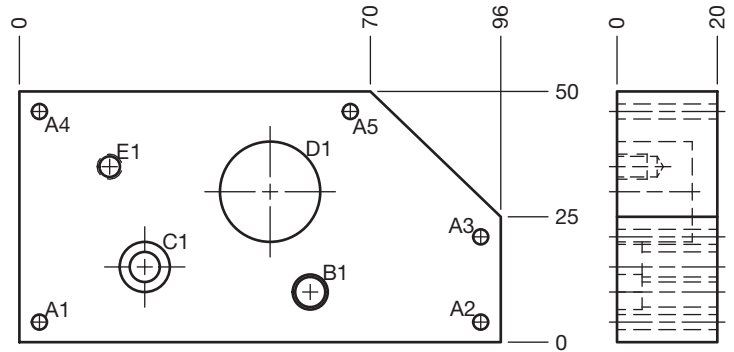
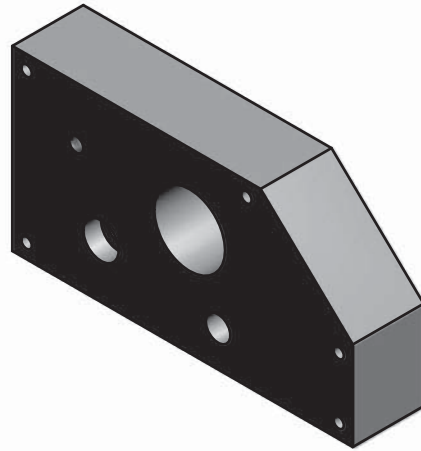


© Cengage Learning 2012

**PROBLEM 10.34 Tabular dimensioning (metric)**

Part Name: Mounting Plate

Material: 7075 Aluminum



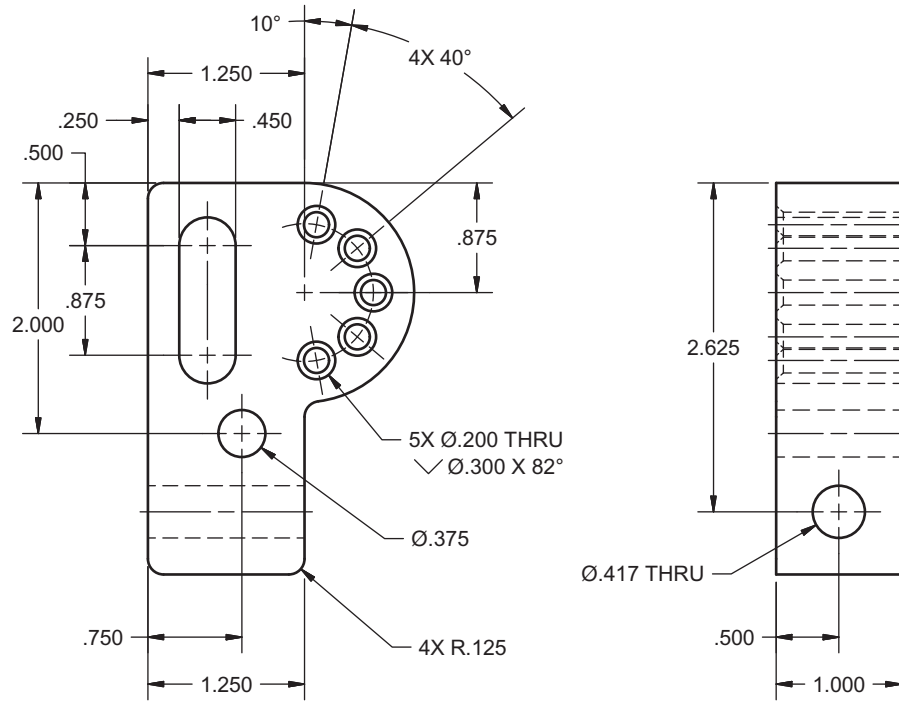
HOLE TABLE			
HOLE	XDIM	YDIM	DESCRIPTION
A1	4.00	4.00	Ø3 THRU
A2	92.00	4.00	Ø3 THRU
A3	92.00	21.00	Ø3 THRU
A4	4.00	46.00	Ø3 THRU
A5	66.00	46.00	Ø3 THRU
B1	58.00	10.00	Ø6 THRU □Ø7 ▽ 5
C1	25.00	15.00	Ø6 THRU □Ø10 ▽ 5
D1	50.00	30.00	Ø20 ▽ 15
E1	18.00	35.00	M5X0.8-6H ▽ 6

© Cengage Learning 2012

**PROBLEM 10.35** Rectangular and polar coordinate dimensioning (in.)

Part Name: Adjustable Hitch

Material: SAE 1085



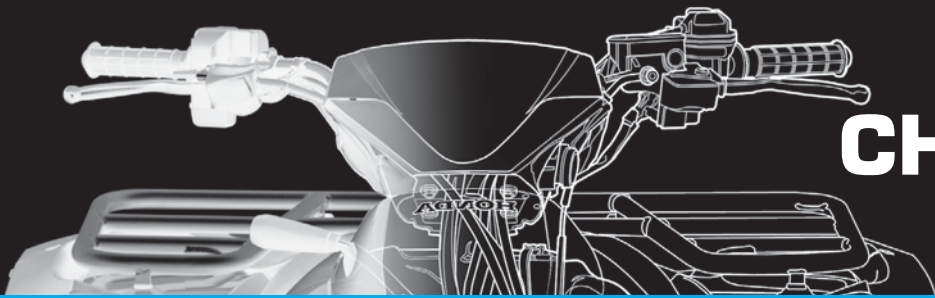
**Math Problems**

**Part 4: Problems 10.36 Through 10.45**



To access the Chapter 10 problems, go to the Student CD, select **Chapter Tests and Problems** and **Chapter 10**, and then open the

math problem of your choice or as assigned by your instructor. Solve the problems using the instructions provided on the CD, unless otherwise specified by your instructor.



# CHAPTER 11

## Fasteners and Springs

### LEARNING OBJECTIVES

After completing this chapter, you will:

- Draw screw thread representations and provide correct thread notes.
- Read, write, and interpret written fastener specifications.
- Prepare drawings for fastening devices.
- Draw completely dimensioned spring representations.
- Prepare formal drawings from engineers' sketches and actual industry layouts.

## THE ENGINEERING DESIGN APPLICATION

You are asked to make a drawing from an engineer's notes for a fastening device that is needed for one of the products the engineer is designing. The engineer's notes look like those in Figure 11.1. You may be thinking:

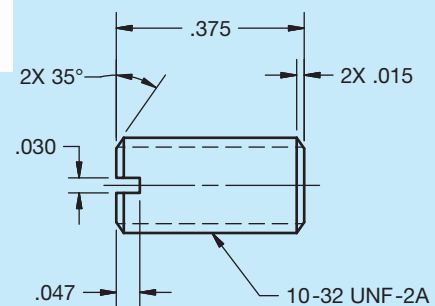
- An option would be to use the screw machine and thread a 10-gage rod with 32 UNF-2A specifications. Another option would be to use a 10-32 UNF-2A threaded rod and cut it to .375 length.
- Then you would need to chamfer both ends with  $.015 \times 35^\circ$  and provide a slot in one end that is  $.030$  wide and  $.047$  deep.

The engineer has provided enough information in the thread note and other specifications. One option for solving the problem is that standard screws and other fasteners can be completely described without a drawing.

10-32 UNF-2A THREADED  
MATERIAL .375 LG.  
W/ .015 LATERAL X 35°  
CHAMFERS ON BOTH ENDS  
PROVIDE A .030 WIDE X  
.047 DEEP SLOT ON  
ONE END.

© Cengage Learning 2012

A written specification can be used to describe an object completely. For example, 1/2-13 UNC-2  $\times$  1.5 LG FIL- LISTER HEAD MACHINE SCREW. In the case of this engineering problem, you decide that a drawing is needed, because there is too much detail for a written specification. Therefore, you go to work preparing the drawing shown in Figure 11.2. The CADD program makes the job very easy, and you can even include a 3-D model in the upper left corner of the drawing. You finish the assignment in less than 30 min.



© Cengage Learning 2012

FIGURE 11.1 Engineer's notes.

FIGURE 11.2 CADD model and drawing from engineer's notes.

## STANDARDS

**ASME** This chapter introduces you to the methods of specifying and drafting **fasteners** and **springs**. Fasteners include screw threads, keys, pins, rivets, and **weldments**. A weldment is an assembly of parts welded together. There are two types of springs: helical and flat. The ASME document that governs the standards for fasteners is ASME Y14.6, *Screw Thread Representation*. There is also an ASME B series of standards with extensive information covering screw threads. The following is a list of the ASME B series of standards:

- ASME B1.1, *Unified Inch Screw Threads* (UN and UNR Thread Form).
- ASME B1.3M, *Screw Thread Gaging Systems for Dimensional Acceptability-Inch and Metric Screw Threads* (UN, UNR, M, and MJ).
- ASME B1.5, *Acme Screw Threads*.
- ASME B1.7M, *Nomenclature, Definitions, and Letter*.
- ASME B1.8, *Stub Acme Screw Threads*.
- ASME B1.9, *Buttress Inch Screw Threads Symbols for Screw Threads*.
- ASME B1.10M, *Unified Miniature Screw Threads*.
- ASME B1.11, *Microscope Objective Thread*.
- ASME B1.12, *Class 5 Interference-Fit Thread*.
- ASME B1.13M, *Metric Screw Threads—M Profile*.
- ASME B1.15, *Unified Inch Screw Threads (UNJ Thread)*.
- ASME B1.20.1, *Pipe Threads, General Purpose (Inch)*.
- ASME B1.20.3, *Dryseal Pipe Threads (Inch)*.
- ASME B1.20.7, *Hose Coupling Screw Threads (Inch)*.
- ASME B1.21M, *Metric Screw Threads: MJ Profile*.

ASME B18.29.1, *Helical Coil Screw Thread Inserts*.

ASME B18.29.2M, *Helical Coil Screw Thread Inserts*.

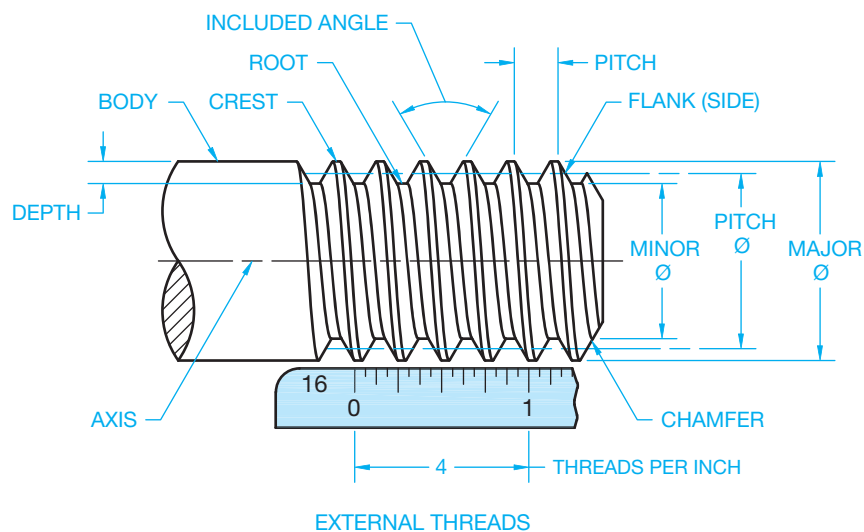
The ASME document that governs the standards for springs is ASME Y14.13M, *Mechanical Spring Representation*.

**AWS** The document that provides recommendations for welding applications is published by the American Welding Society (AWS). The document is AWS A2.4-2007, *Standard Symbols for Welding, Brazing and Nondestructive Examination*. Although welding is a fastening application, it is not described in this chapter, because of the extensive nature of representations and applications. Chapter 18, *Welding Processes and Representations*, covers this subject in detail.

## SCREW THREAD FASTENERS

**Screw threads** are helix or conical spirals formed on the external surface of a shaft or internal surface of a cylindrical hole. The features and related terminology for external and internal screw threads are shown in Figures 11.3 and 11.4. Screw threads are used for an unlimited number of applications, such as holding parts together as fasteners, leveling and adjusting objects, transmitting power from one object or feature to another, and as covers for containers.

The standardization of screw threads was achieved in the United States, United Kingdom, and Canada in 1949. A need for interchangeability of screw thread fasteners was the purpose of this standardization and resulted in the Unified Thread Series. The Unified Thread Series is now the American standard for screw threads. Before 1949, the United States standard was the American National screw threads. The unification standard occurred because of combining some of the characteristics of the American



**FIGURE 11.3** External screw thread components and terminology.



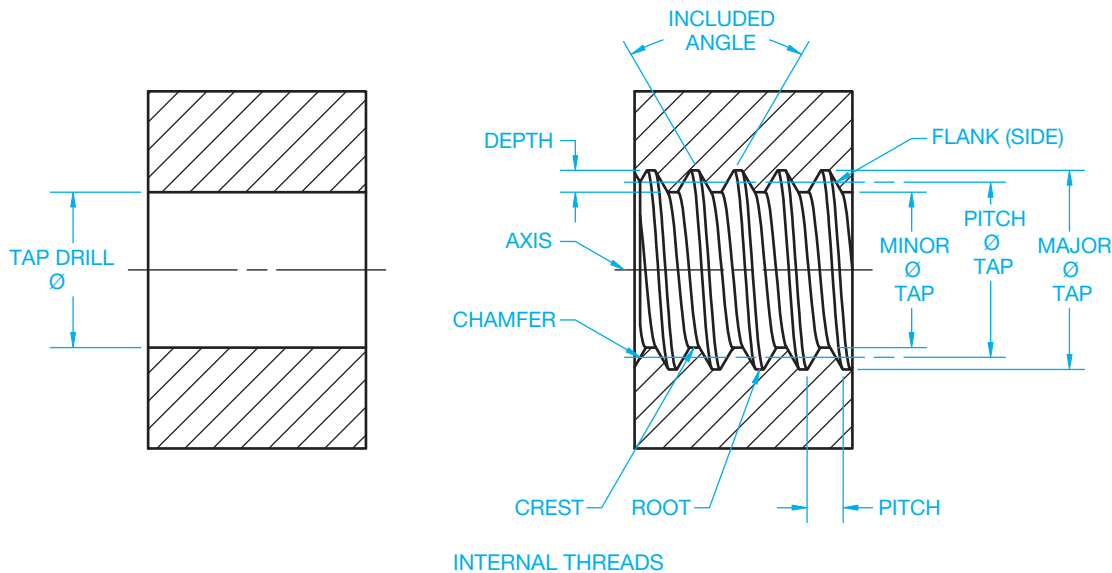


FIGURE 11.4 Internal screw thread components and terminology.

© Cengage Learning 2012

National screw threads with the United Kingdom's long-accepted Whitworth screw threads. Screw thread systems were revised again in 1974 for metric application. The modifications were minor and based primarily on metric translation. To emphasize that the Unified screw threads evolve from inch calibrations, the term *Unified Inch Screw Threads* is used while the term *Unified Screw Threads Metric Translation* is used for the metric conversion.

## Screw Thread Terminology

Refer to Figures 11.3 and 11.4 as a reference for the following definitions related to external and internal screw threads:

**Axis:** The thread axis is the centerline of the cylindrical thread shape.

**Body:** Sometimes referred to as the **shank**, that portion of a screw shaft that is left unthreaded.

**Chamfer:** An angular relief at the last thread to help allow the thread to engage with a mating part more easily.

**Classes of Threads:** A designation of the amount of tolerance and allowance specified for a thread.

**Crest:** The top of external threads and the bottom of internal threads.

**Depth of Thread:** Depth is the distance between the crest and the root of a thread as measured perpendicular to the axis.

**Die:** A machine tool used for cutting external threads.

**Fit:** Identifies a range of thread tightness or looseness.

**Included Angle:** The angle between the flanks (sides) of the thread.

**Lead:** The lateral distance a thread travels during one complete rotation.

**Left-Hand Thread:** A thread that engages with a mating thread by rotating counterclockwise or with a turn to the left when viewed toward the mating thread.

**Major Diameter:** The distance on an external thread from crest to crest through the axis. For an internal thread, the major diameter is measured from root to root across the axis.

**Minor Diameter:** The dimension from root to root through the axis on an external thread and measured across the crests through the center for an internal thread.

**Pitch:** The distance measured parallel to the axis from a point on one thread to the corresponding point on the adjacent thread.

**Pitch Diameter:** A diameter measured from a point halfway between the major and minor diameter through the axis to a corresponding point on the opposite side.

**Right-Hand Thread:** A thread that engages with a mating thread by rotating clockwise or with a turn to the right when viewed toward the mating thread.

**Root:** The bottom of external and the top of internal threads.

**Runout:** As applied to screw threads, this term refers to circular runout of major or minor cylinders with respect to the pitch cylinder. Also see *vanish thread* below.

**Tap:** The machine tool used to form an interior thread. Tapping is the process of making an internal thread.

**Tap Drill:** A tap drill is used to make a hole in material before tapping.

**Thread:** The part of a screw thread represented by one pitch.

**Thread Form:** The design of a thread determined by its profile.

**Thread Series:** Groups of common major diameter and pitch characteristics determined by the number of threads per inch.

**Threads per Inch:** The number of threads measured in 1 in. The reciprocal of the pitch in inches.

**Vanish Thread:** Also referred to as a *partial thread*, *wash-out thread*, or *thread runout*. That portion of the incomplete thread that is not fully formed at root or at crest and root. Vanish is produced by the chamfer at the starting end of the thread-forming tool.

## THREAD-CUTTING TOOLS

A **tap** is a machine tool used to form an internal thread as shown in Figure 11.5. A **die** is a machine tool used to form external threads (see Figure 11.6).

A **tap set** is made up of a taper tap, a plug tap, and a bottoming tap as shown in Figure 11.7. The **taper tap** is generally used for starting a thread. The threads are tapered to within ten threads from the end. The tap is tapered so the tool evenly distributes the cutting edges through the depth of the hole. The **plug tap** has the threads tapered to within five threads from the end. The **plug tap** has the threads tapered to within five threads from the end. The **plug tap** can be used to completely thread through

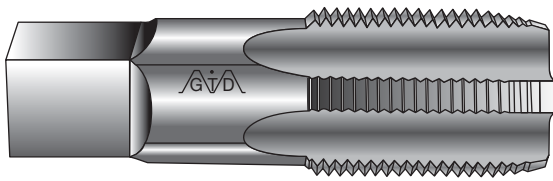


FIGURE 11.5 Tap.

Courtesy Greenfield Tap & Die, Division of TRW, Inc.

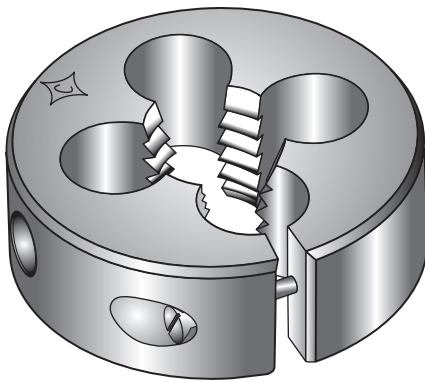


FIGURE 11.6 Die.

Courtesy Greenfield Tap & Die, Division of TRW, Inc.

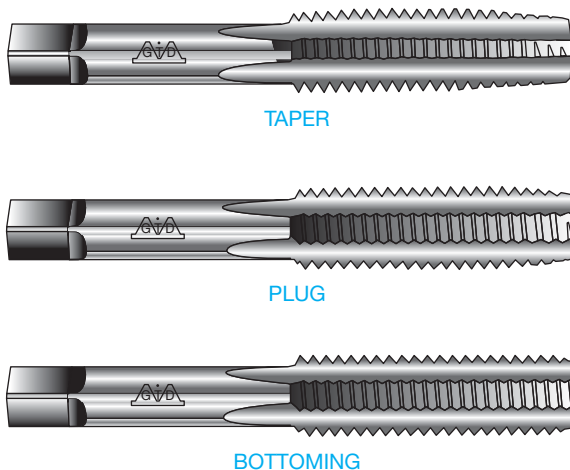


FIGURE 11.7 Tap set includes taper, plug, and bottoming taps.

Courtesy Greenfield Tap & Die, Division of TRW, Inc.

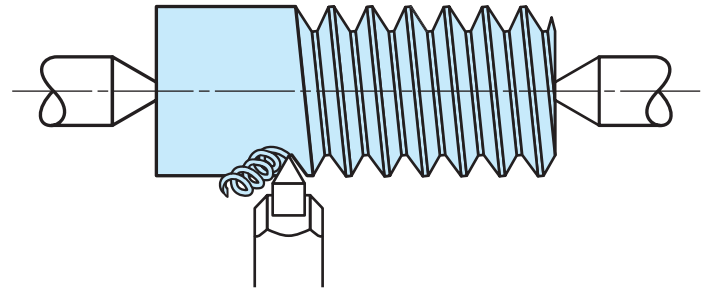


FIGURE 11.8 Thread cutting on a lathe. © Cengage Learning 2012

material or thread a **blind hole** if full threads are not required all the way to the bottom. A blind hole is a hole that does not go through the material. The **bottoming tap** is used when threads are needed to the bottom of a blind hole.

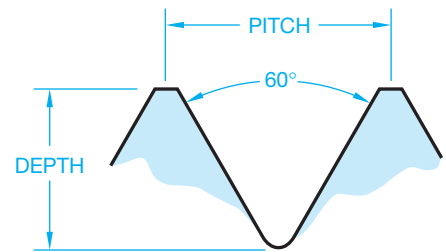
The **die** is a machine tool used to cut external threads. Thread-cutting dies are available for standard thread sizes and designations.

External and internal threads can also be cut on a **lathe**. A lathe is a machine that holds a piece of material between two centers or in a chucking device. The material is rotated as a cutting tool removes material while traversing along a carriage that slides along a bed. Figure 11.8 shows how a cutting tool can make an external thread.

## THREAD FORMS

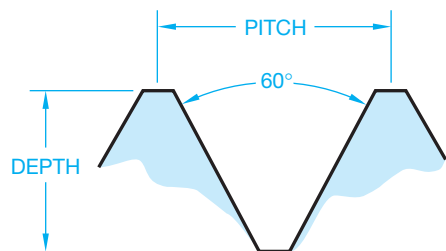
**Unified threads** are the most common threads used on threaded fasteners. Figure 11.9 shows the profile of a unified thread.

**American National threads**, shown in profile in Figure 11.10, are similar to the unified thread but have a flat root. Still in use today, the American National thread has generally replaced the sharp-V thread form.



© Cengage Learning 2012

FIGURE 11.9 Unified thread form. The unified thread form is the most commonly used thread.



© Cengage Learning 2012

FIGURE 11.10 American National thread form.

The **sharp-V thread**, although not commonly used, is a thread that fits and seals tightly. It is difficult to manufacture because the sharp crests and roots of the threads are easily damaged (see Figure 11.11). The sharp-V thread was the original United States standard thread form.

**Metric thread** forms vary slightly from one European country to the next. The International Organization for Standardization (ISO) was established to standardize metric screw threads. The ISO thread specifications are similar to the unified thread form (see Figure 11.12).

**Whitworth threads** are the original British standard thread forms developed in 1841. These threads have been referred to as *parallel screw threads*. The Whitworth thread forms are primarily used for replacement parts (see Figure 11.13).

**Square thread** forms, shown in Figure 11.14, have a longer pitch than unified threads. Square threads were developed as threads that would effectively transmit power. Square threads are difficult to manufacture because of their perpendicular sides. There are modified square threads with  $10^\circ$  sides. The square thread is generally replaced by Acme threads.

**Acme thread** forms are commonly used when rapid traversing movement is a design requirement. Acme threads are

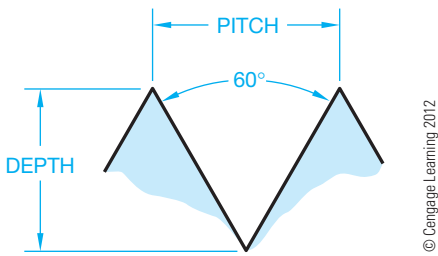


FIGURE 11.11 Sharp-V thread form.

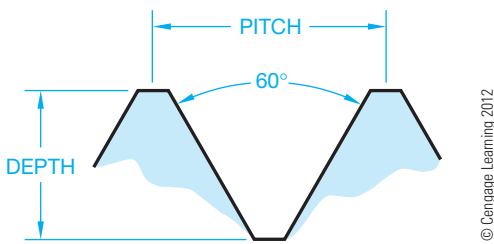


FIGURE 11.12 Metric thread form.

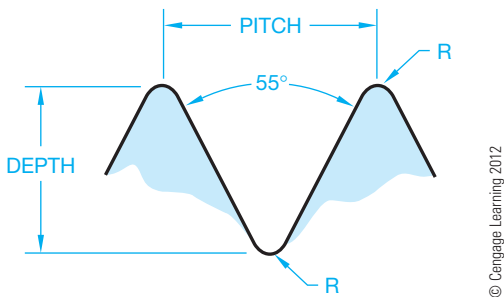


FIGURE 11.13 Whitworth thread form.

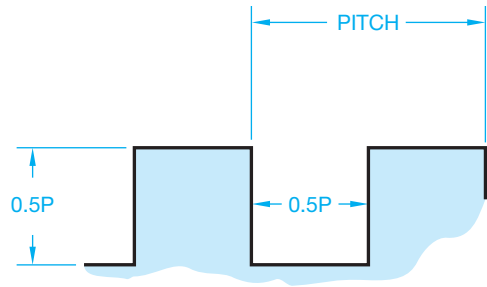


FIGURE 11.14 Square thread form.

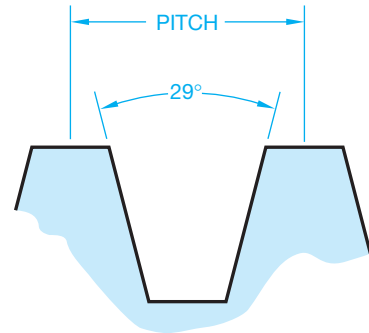


FIGURE 11.15 Acme thread form.

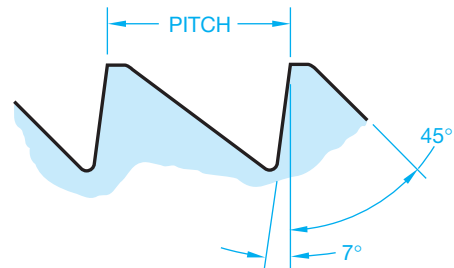


FIGURE 11.16 Buttress thread form.

popular on such designs as screw jacks, vise screws, and other equipment and machinery that require rapid screw action. A profile of the Acme thread form is shown in Figure 11.15.

**Buttress threads** are designed for applications where high stress occurs in one direction along the thread axis. The thread flank or side that distributes the thrust or force is within  $7^\circ$  of perpendicularity to the axis. This helps reduce the radial component of the thrust. The buttress thread is commonly used in situations where tubular features are screwed together and lateral forces are exerted in one direction (see Figure 11.16).

**Darlet thread** forms are primarily used in situations where a self-locking thread is required. These threads resist vibrations and remain tight without auxiliary locking devices (see Figure 11.17).

**Rolled thread** forms are used for screw shells of electric sockets and lamp bases (see Figure 11.18).

**American National Standard taper pipe threads** are the standard threads used on pipes and pipe fittings. These threads

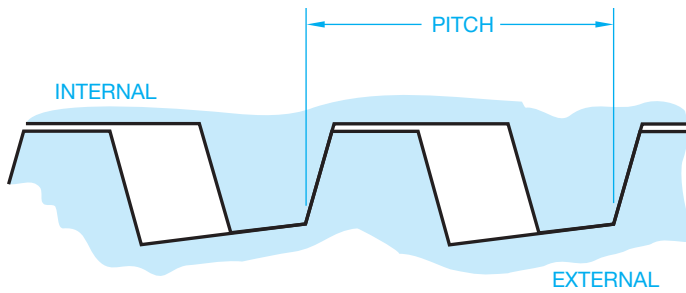


FIGURE 11.17 Dardelet self-locking thread form. © Cengage Learning 2012

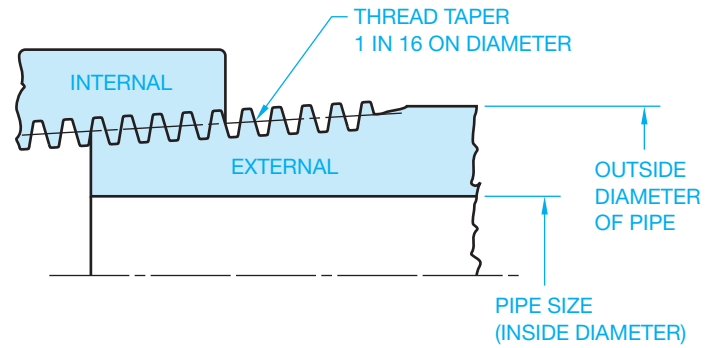


FIGURE 11.19 American National Standard taper pipe thread form. © Cengage Learning 2012

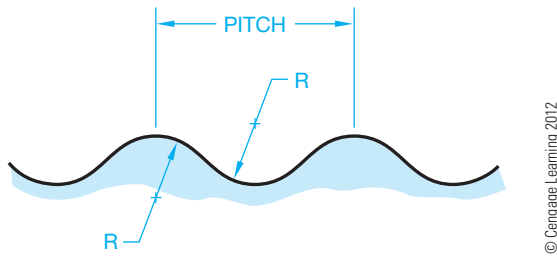


FIGURE 11.18 Rolled thread form.

are designed to provide pressure-tight joints or not, depending on the intended function and materials used. American pipe threads are measured by the **nominal pipe size**, which is the inside pipe diameter. For example, a 1/2 in. nominal pipe size has an outside pipe diameter of .840 in. (see Figure 11.19). Pipe thread design considerations and drafting practices are discussed later in this text.

### THREAD REPRESENTATIONS

Three methods of thread representation are in use: detailed, schematic, and simplified, as shown in Figure 11.20. The **detailed representation** is used in special situations that require a pictorial display of threads, such as in a sales catalog or a display drawing, because they represent the appearance of the actual thread form. **Schematic representations** show the threads as a symbol rather than as they actually look. Some companies prefer to use the schematic thread representation, but the simplified thread representation, described next, is most commonly used.

The actual use and purpose of the drawing helps determine which thread symbol to draw. It is possible to mix representations on a particular drawing if clarity is improved, but this practice is generally avoided. The simplified representation is the most common method of drawing thread symbols. **Simplified representations** clearly describe threads, and they are easy

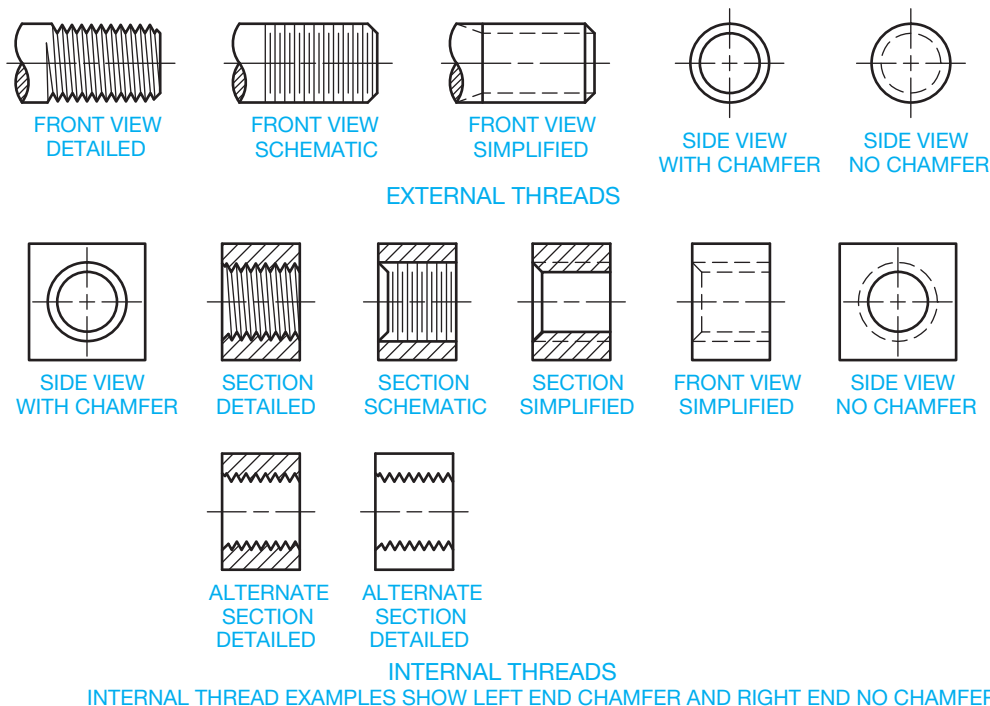
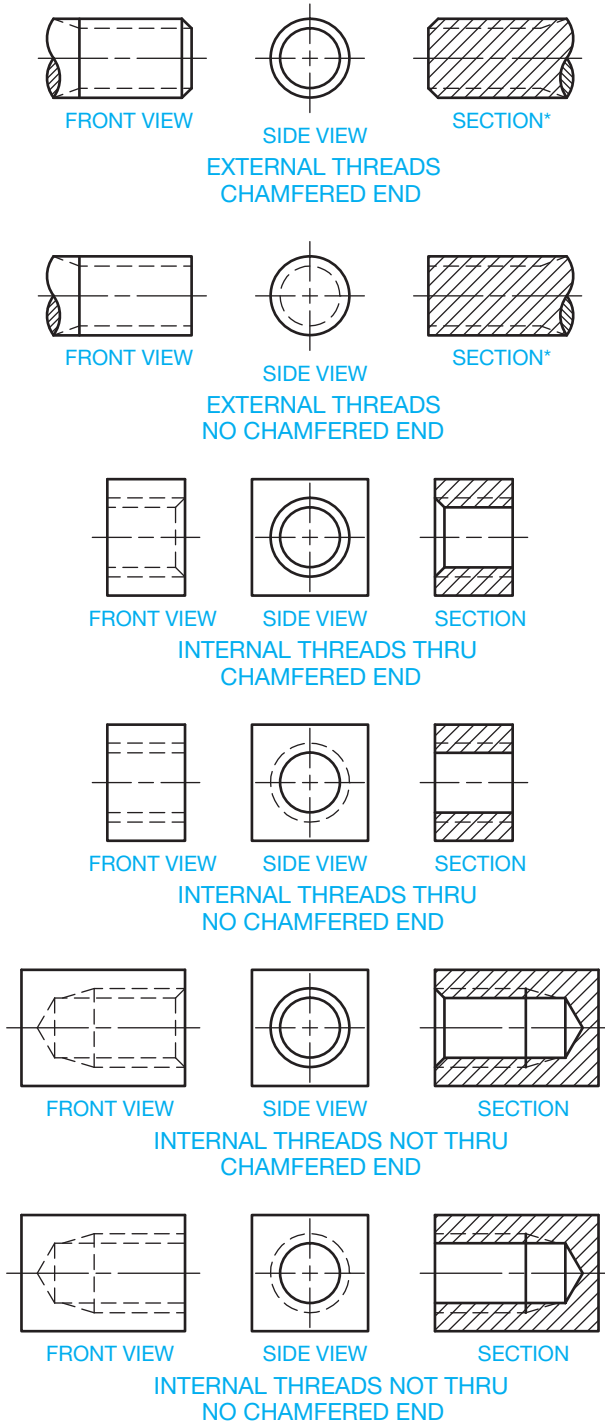


FIGURE 11.20 Thread representations.

and quick to draw. They are also very versatile and can be used in all situations, whereas the other representations cannot be used in all situations. Figure 11.21 shows simplified threads in different applications.

Also, notice how the use of a thread chamfer slightly changes the appearance of the thread. Chamfers are commonly applied to the first thread to help start a thread in or onto its mating part.



**FIGURE 11.21** Simplified thread representations. \*Threaded shafts area not sectioned unless there is a need to expose an internal feature.

When an internal screw thread does not go through the part, it is common to drill deeper than the depth of the required thread when possible. This process saves time and reduces the chance of breaking a tap during the threading operation. The thread can go to the bottom of a hole, but to produce it requires an extra process using a bottoming tap and some clearance. Figure 11.22 shows a simplified representation of a thread that does not go through. The tap drill is deeper than the thread, and the thread vanish or runout continues past the full thread depth. The vanish is represented as an arc that begins at the end of the full thread and ends into the extended minor diameter. The vanish is drawn as a representation of runout and is not dimensioned unless a dimension is required for design purposes. The bolt used for the application should be shorter than the depth of thread so the bolt does not hit the bottom of the thread. Notice in Figure 11.22 that the hidden lines representing the major and minor thread diameters are spaced far enough apart to be clearly separate. This spacing is important because on some threads, the difference between the major and minor diameters is very small and the lines run together if drawn as they actually appear. The hidden line dashes are also drawn staggered for clarity. Figure 11.23 shows a bolt fastener as it appears drawn in assembly with two parts using simplified thread representation.

### DRAWING THREAD REPRESENTATIONS

CADD software programs offer varying degrees of automation for drawing screw thread representations. Most 2-D applications allow you to create a screw thread symbol and use it every time you need to insert the same screw thread representation. Some programs allow you to make a symbol dynamic, which means that when you insert the symbol you can enter screw and thread specifications to create the desired thread representation. Once you create a symbol, you should always copy it or make a saved symbol for multiple use. The parametric 2-D drawing capabilities of some 3-D solid modeling programs allow you to extract existing model information to create the 2-D thread representation. Most systems display simplified thread representations in the 2-D drawing environment. You must typically model actual 3-D thread geometry to display detailed threads in a drawing.

As a beginning drafter using a 2-D CADD program, you can use the steps presented in the following to help you create the first screw thread representation for your drawings. You can use the following steps to create any of the three standard screw thread representations.

### Drawing Simplified Threads

Simplified representations are the easiest thread symbols to draw and are the most common in industry. The following steps show how to draw simplified threads:

- STEP 1** Draw the major thread diameter as an object line for external threads and hidden line for internal threads as in Figure 11.24.

© Cengage Learning 2012

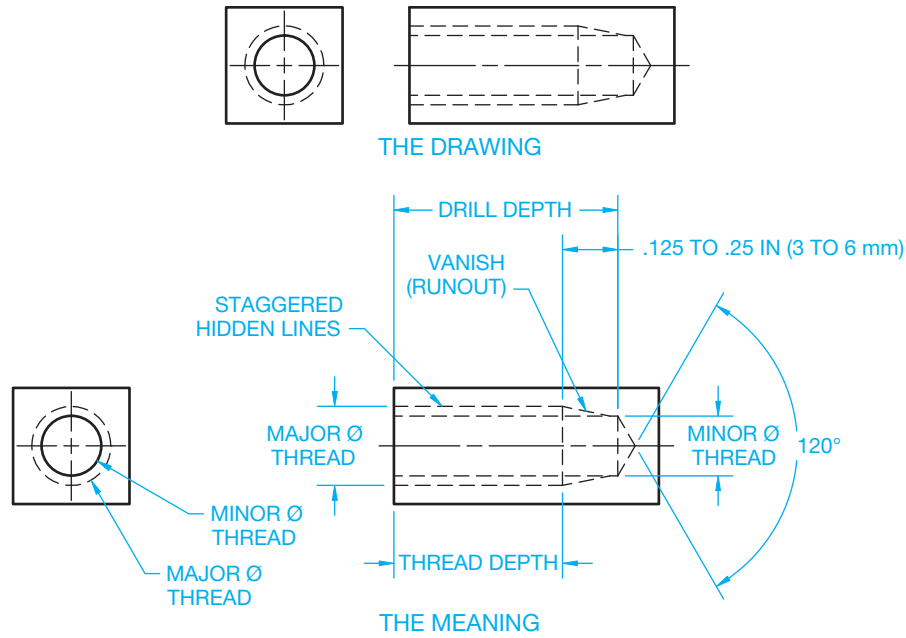


FIGURE 11.22 This simplified internal thread that does not go through the part.

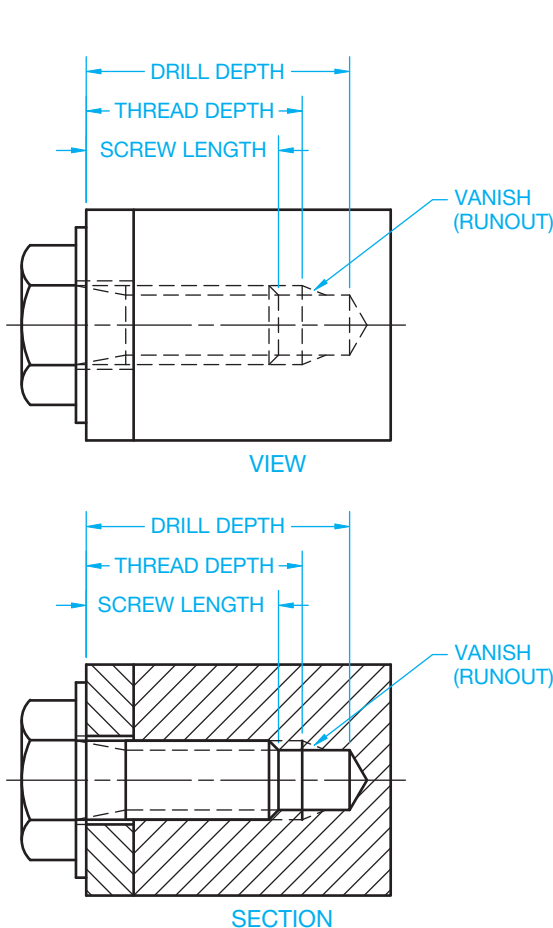


FIGURE 11.23 The simplified external thread in a threaded assembly where the thread does not go through the part.

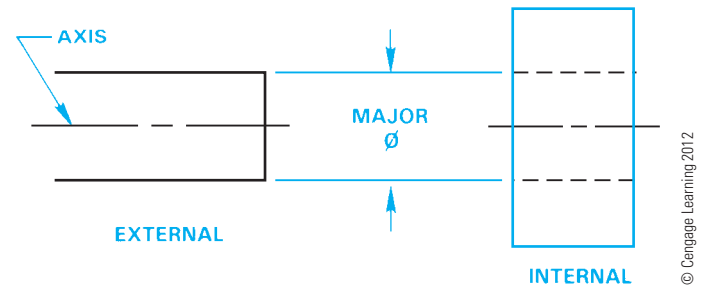


FIGURE 11.24 Step 1: Establishing the major thread diameter.

**STEP 2** Draw the minor thread diameter, which is about equal to the tap drill size found in a tap drill chart. If the minor diameter and major diameter are too close together, then slightly exaggerate the space. A minimum space of .016 in. (4 mm) is recommended. The minor diameter is a hidden line for the external thread and a hidden line staggered with the major diameter lines for the internal thread. The minor diameter is an object line for the internal thread in section (see Figure 11.25). You can determine the tap drill size for a specific thread specification by looking at Appendix R in this textbook or refer to the *Machinery's Handbook*. A section is a view used to describe the interior portions of an object that are otherwise difficult to visualize. Interior features that are described using hidden lines are not as clear as if they are exposed for viewing as visible features. Sectioning is described in detail in Chapter 12, *Sections, Revolutions, and Conventional Breaks*.

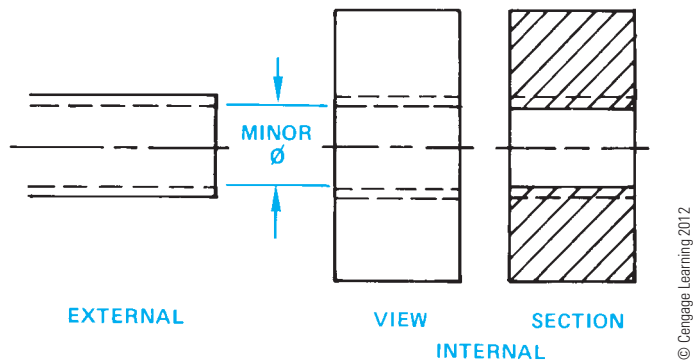


FIGURE 11.25 Step 2: Establishing the minor diameter.

When using AutoCAD, for example, the object lines are drawn with a continuous line type, and the hidden lines are drawn with a hidden line type. The line weights can be set to display the proper line contrast between object lines and hidden lines. The lines can also be put on their own layers as needed. Simplified thread symbols can also be inserted as blocks in AutoCAD and scaled as needed upon insertion. When using a 3-D modeling program, such as Autodesk Inventor, ProEngineer, NX, or SolidWorks, you can extract information from the 3-D model to create the 2-D simplified thread representation automatically.

## Drawing Schematic Threads

Schematic thread representations are drawn to approximate the appearance of threads by spacing lines that represent the pitch of the thread. When there are too many threads per inch to draw without crowding, then the distance should be exaggerated for clarity. Schematic thread representations are not used for hidden internal threads or for sectioned external threads. The following steps show how to draw schematic thread representations:

**STEP 1** Draw the major diameter of the thread. Schematic symbols can only be drawn in section for internal threads. Then lay out the number of threads per inch using a thin line at each space. You can only use the actual number of threads per inch as the spacing if distance is far enough apart to provide a clear representation without crowding. If you are making a schematic thread representation with eight threads per inch at full scale, then the spacing is 1/8 in. between threads, which is acceptable. If your thread has 24 threads per inch at full scale, then you need to exaggerate the distance between threads for clarity. You should maintain a minimum of about .016 in. (4 mm) between the lines of a schematic thread representation, regardless of the number of threads per inch or the drawing scale. Figure 11.26 uses eight threads per inch.

**STEP 2** Draw a thin line equal in length to the minor diameter between each pair of thin lines drawn in Step 1 (see Figure 11.27). Depending on your CADD program, certain commands allow you to equally space multiple lines at the same time.

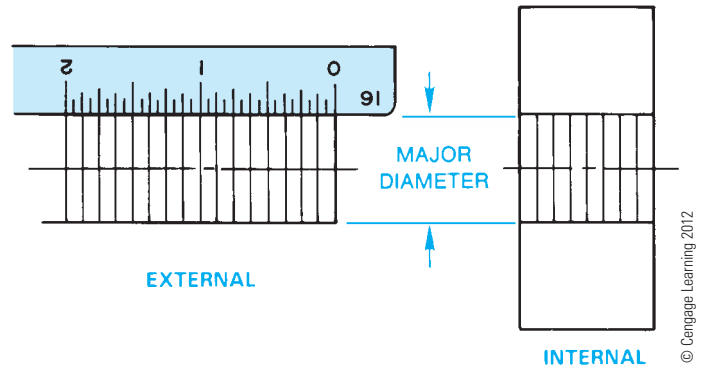


FIGURE 11.26 Step 1: Establishing the major diameter and the number of threads per inch on the schematic thread.

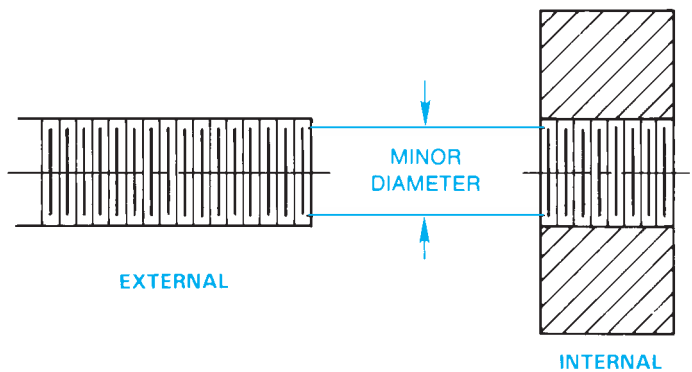


FIGURE 11.27 Step 2: Establishing the minor diameter and completing the schematic thread. © Cengage Learning 2012

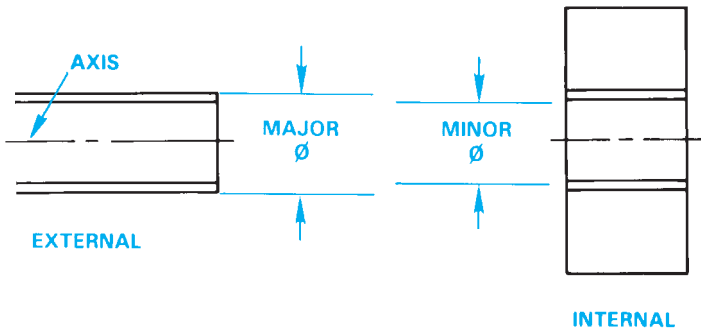
When using AutoCAD, for example, the lines are drawn with a continuous line type. The line weights can be set to display the proper line contrast. The longer lines representing the major diameter and the shorter lines representing the minor diameter are drawn as thin lines that are the same thickness as other thin lines in your drawing. The lines can be put on their own layers as needed. The lines representing the schematic threads can also be copied as needed with a command such as ARRAY that makes multiple copies of an object. Schematic thread symbols can be constructed and inserted as CADD symbols, such as AutoCAD blocks, and scaled as needed upon insertion.

## DRAWING DETAILED THREADS

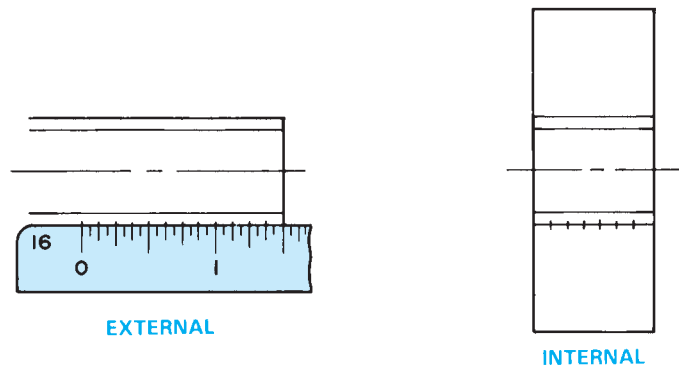
Detailed thread representations are the most difficult and time-consuming thread symbols to draw. Detailed thread representations are necessary for some applications as they most closely approximate the actual thread appearance. Detailed external and sectioned threads can be drawn, but detailed internal threads cannot be drawn in multiview, because they cannot be shown as hidden lines. Detailed internal threads can only be drawn in

section. The following steps show how to draw detailed thread representations for external and internal threads in section:

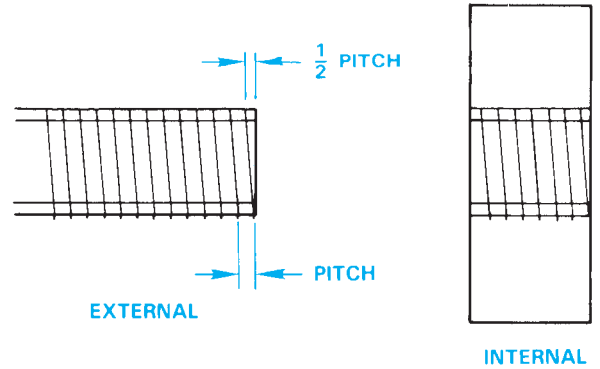
- STEP 1** Use construction lines to lightly draw the major and minor diameters of the thread as shown in Figure 11.28.
- STEP 2** Divide one edge of the thread into equal parts. Eight threads per inch are used in this example, so the pitch is .125 in., as shown in Figure 11.29. If the pitch is too small, such as less than .125 in., then exaggerate the distance to avoid crowding. Remember, thread representations should have an appearance close to the actual thread, but they do not have to be exact if the result is too difficult to draw or unclear because of crowding.
- STEP 3** Stagger the opposite side one-half pitch and draw parallel thin lines equal to the spaces established in Step 2 (see Figure 11.30).
- STEP 4** Draw V's at 60° to form the root and crest of each thread (see Figure 11.31).
- STEP 5** Complete the detailed thread representation by connecting the roots of opposite threads by drawing parallel lines as shown in Figure 11.32. The detailed thread representation is not an exact duplication of an actual screw thread, because an actual thread has a helical shape and additional thread detail that is not necessary to represent on the drawing.



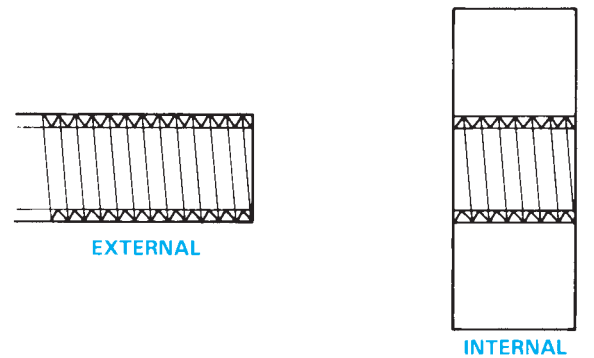
**FIGURE 11.28** Step 1: Establishing the major and minor diameters for the detailed thread. © Cengage Learning 2012



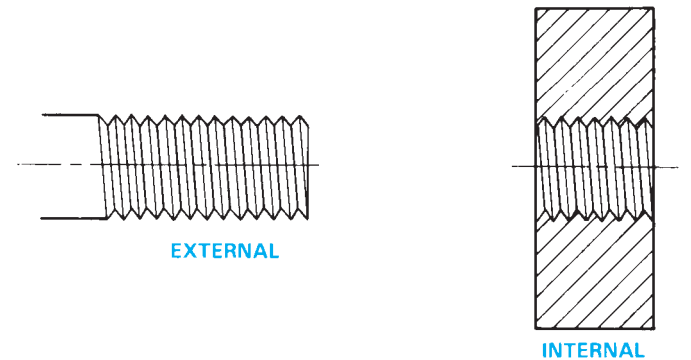
**FIGURE 11.29** Step 2: Establishing the number of threads per inch on the detailed thread. © Cengage Learning 2012



**FIGURE 11.30** Step 3: Constructing the thread pitch on the detailed thread.



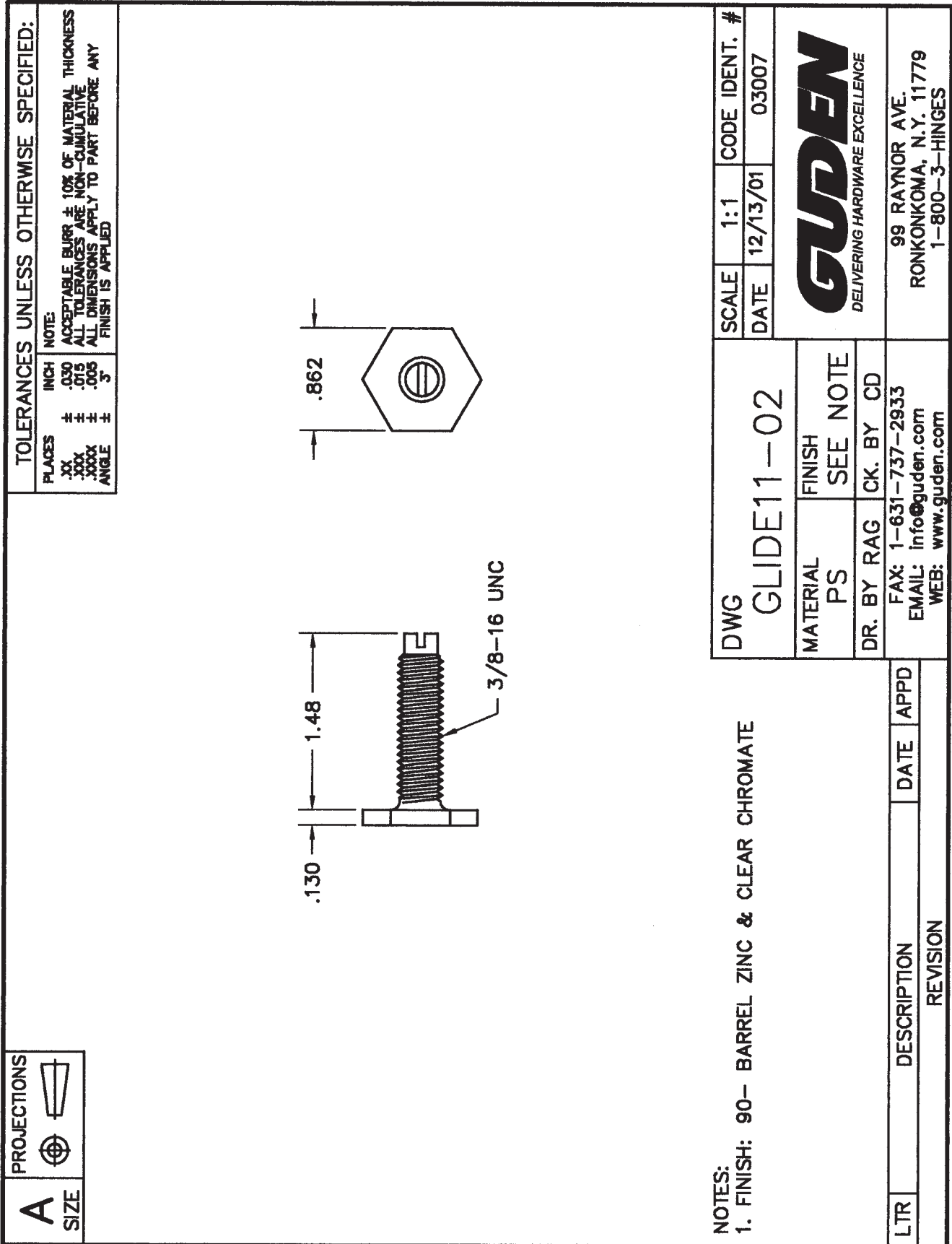
**FIGURE 11.31** Step 4: Drawing the thread form on the detailed thread.



**FIGURE 11.32** Step 5: The complete detailed thread representation.

When using AutoCAD, for example, the object lines are drawn with a continuous line type. You can draw one V thread form and then use the ARRAY command to conveniently copy the desired number of threads onto one side of the fastener. Then use the MIRROR command to copy the threads to the other side and the MOVE command to move them over one-half pitch. Then draw one set of major diameter and minor diameter lines and use the ARRAY command to duplicate them across the entire thread. Use the TRIM command as needed to finish the thread detail. The thread representation can be put on its own layer as needed. Detailed thread symbols can also be created as a block and then scaled as needed upon insertion.





**FIGURE 11.33** An industry drawing using the detailed thread representation.

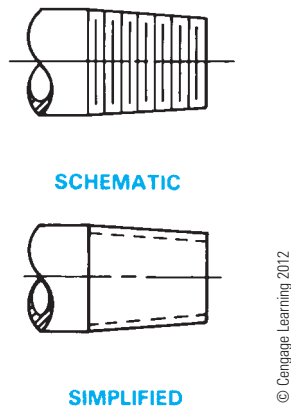


FIGURE 11.34 Tapered pipe thread representation.

Detailed thread representations can be used to draw any thread form using the same steps previously shown. The difference occurs in drawing the profile of the thread. For example, V's are used to draw unified, sharp-V, American Standard, and metric threads. The profile changes for other threads. An industry drawing of a fastener using a detail thread representation is shown in Figure 11.33.

The detailed thread drawings for American National Standard taper pipe threads are the same as for unified threads except that the major and minor diameters taper at a rate of .0625 in./in. Figure 11.34 shows the schematic and simplified representations for tapered pipe threads. The thread note clearly defines the type of thread. Additional information about pipe thread design and drafting is provided later in this chapter.

## THREAD NOTES

Simplified, schematic, and detailed thread representations clearly show where threads are displayed on a drawing. Thread representations alone do not give the full information about the thread. As the term **representation** implies, the symbols are not meant to be exact but to describe the location of a thread where used. The information that clearly and completely identifies the thread being used is the **thread note**. The thread note must always be in the same order and must be accurate. The thread will be manufactured incorrectly if the thread note is not displayed properly or if the content is inaccurate.

## Unified and American National Threads

The thread note is always drawn in the order shown, and the components of the note are described as follows:

**1/2–13 UNC–2 A**

(A) (B) (C) (D)(E)(F)(G) (H)

- (A) The major diameter of the thread in inches followed by a dash (–). The major diameter is generally given as a fractional value. The fraction numerals can be stacked with a horizontal fraction bar or using a diagonal fraction bar

as in this example. The fraction numerals should be the same height as the other text on the drawing. Confirm the preferred practice with your school or company.

- (B) Number of threads per inch.
- (C) Series of threads are classified by the number of threads per inch as applied to specific diameters and thread forms, such as coarse or fine threads. In this example, UNC means Unified National Coarse. Others include UNF for Unified National Fine, UNEF for Unified National Extra Fine, or UNS for Unified National Special. The UNEF and UNS thread designations are for special combinations of diameter, pitch, and length of engagement. American National screw threads are identified with UN for external and internal threads, or UNR, a thread designed to improve fatigue strength of external threads only. The series designation is followed by a dash (–).
- (D) Class of fit is the amount of tolerance. The numeral 1 means a large tolerance, 2 is a general-purpose moderate tolerance, and 3 is for applications requiring a close tolerance.
- (E) Shown in the example, A means an external thread. B used in this location means an internal thread. (B replaces A in this location.) The A or B can be omitted if the thread shown on the drawing is clearly external or internal.
- (F) A blank space at (F) means a right-hand thread. A right-hand thread is assumed. LH in this space identifies a left-handed thread.
- (G) A blank space at (G) identifies a thread with a single lead. A single lead is a thread that engages one pitch when rotated 360°. If a double or triple lead is required, the letter L and a value are used to specify double and triple lead. The L means lead, and the value is 2X pitch for double lead threads.
- (H) This location is for internal thread depth or external thread length in inches. This space is left blank when the drawing clearly shows that the internal thread goes through the part. If clarification is needed, then the word THRU is placed here.

## STANDARDS

ASME recommends the controlling organization and thread standard be specified here or as a general note on the drawing. For example, ASME B1.1.

The abbreviation MOD is placed here, and the modification is specified under the thread designation if the thread is to be modified in some way. For example, a standard thread with a modified major diameter is designated as 3/8-24 UNF-3A MOD (21)

MAJOR DIA .3648–.3720 MOD

The ASME standard also recommends that the thread gaging standard be added to the thread note. For example, (21)

**M6X1-5H6H (21), ASME B1.13M**

The value in parenthesis is the thread gaging system. ASME B1.1, *Inch Screw Thread Designation*; ASME B1.13M, *Metric Screw Thread Designation*; and ASME B1.3, *Screw Thread Gaging Systems*, all recommend adding the gaging system to the thread callout. This is to ensure that all the individuals involved in design, manufacturing, and inspection know how the threads are to be verified. This is especially important when items are manufactured outside the United States. As explained in ASME B1.3, the gaging system numbers are (21), (22), and (23). Gaging system (21) is a **go-no-go gage**. System (22) is a go-no-go gage and the minimum pitch diameter must be verified. System (23) is a go-no-go gage, minimum pitch diameter verification, and other elements such as lead, flank angles, taper, and roundness may have to be independently verified. A go-no-go gage is an instrument that determines whether a part feature simply passes or fails inspection. No effort is made to determine the exact degree of error.



**NOTE:** Numbered series threads are major thread diameters less than 1/4 in. These threads are specified by the screw number 0 through 12, which is the gage diameter from which the thread is manufactured. Numbered series threads are designated by their number followed by the decimal value of the major diameter in parenthesis. For example, 10 (.190) -32 UNF-2A.

## Metric Threads

The metric thread notes shown below are the recommended standard as specified by the ISO. The note components are described as follows:

### M 10×1.5–6H

(A) (B) (C) (D) (E) (F)

- (A) M is the symbol for ISO metric threads and is always placed in this location.
- (B) The nominal major diameter in millimeters, followed by the symbol X, meaning *by*.
- (C) The thread pitch in millimeters, followed by a dash (–).
- (D) The number can be a 3, 4, 5, 6, 7, 8, or 9, which identifies the grade of tolerance from fine to coarse. The larger the number, the larger the tolerance. Grades 3 through 5 are fine, and 7 through 9 are coarse. Grade 3 is very fine, and grade 9 is very coarse. Grade 6 is the most commonly used and is the medium tolerance metric thread. The grade 6 metric thread is comparable to the class 2 unified screw thread. A letter placed after the number gives the thread tolerance class of the internal or external thread. Internal threads are designated by uppercase letters such as G or H, where

G means a tight allowance and H identifies an internal thread with no allowance. The term **allowance** refers to the tightness of fit between the mating parts. External threads are defined with lowercase letters such as e, g, or h. For external threads, e indicates a large allowance, g is a tight allowance, and h establishes no allowance. Grades and tolerances below 5 are intended for tight fits with mating parts, and those above 7 are a free class of fit intended for quick and easy assembly. When the grade and allowance are the same for both the major diameter and the pitch diameter of the metric thread, then the designation is given as 6H, as shown in this example. In some situations in which precise tolerances and allowances are critical between the major and pitch diameters, separate specifications could be used—for example, 4H 5H, or 4g 5g, where the first group (4g) refers to the grade and allowance of the pitch diameter, and the second group (5g) refers to the grade and tolerance of the major diameter. A fit between a pair of threads is indicated in the same thread note by specifying the internal thread followed by the external thread specifications separated by a slash: for example, 6H/6g.

- (E) A blank space at (E) indicates a right-hand thread. A right-hand thread is assumed unless an LH is entered in this space. LH describing a left-hand thread must be specified for a thread that engages when rotated to the left.
- (F) The depth of internal threads or the length of external threads in millimeters is provided at the end of the note. When the thread goes through the part, this space is left blank, although some companies prefer to use the description THRU for internal threads that go through the part.

## Other Thread Forms

Other thread forms, such as Acme, are noted on a drawing using the same format. For example, 5/8–8 ACME–2 describes an Acme thread with a 5/8 in. major diameter, eight threads per inch, and a general-purpose class 2 thread fit. For a complete analysis of threads and thread forms, refer to the *Machinery's Handbook* published by Industrial Press, Inc.

American National Standard taper pipe threads are noted in the same manner with the letters NPT (National Pipe Thread) used to designate the thread form. A typical note reads 3/4–14 NPT. Additional information about pipe thread design is provided later in this chapter.

## Thread Notes on a Drawing

The thread note is usually applied to a drawing with a leader in the view where the thread appears as a circle for internal threads as shown in Figure 11.35. External threads can be dimensioned with a leader as shown in Figure 11.36, with the thread length given as a dimension or at the end of the note. An internal thread that does not go through the part can be

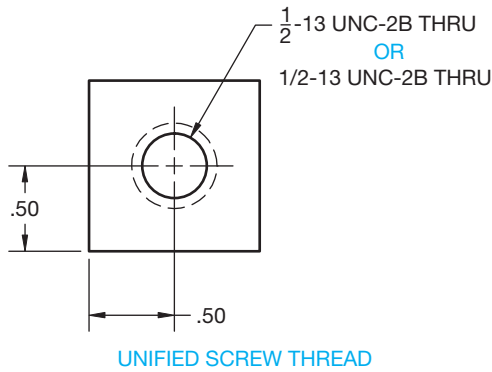


FIGURE 11.35 Drawing and noting internal screw threads using a simplified representation.

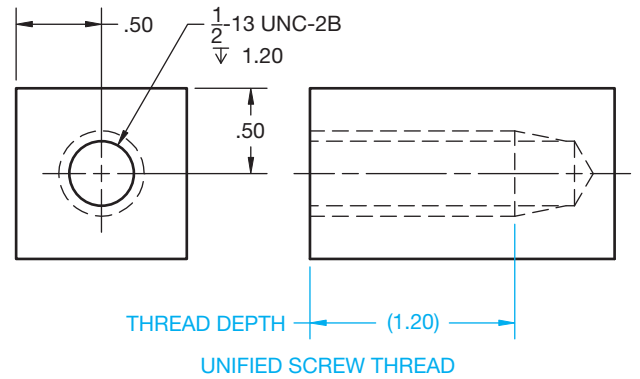


FIGURE 11.37 Drawing and noting internal screw threads with a given depth.

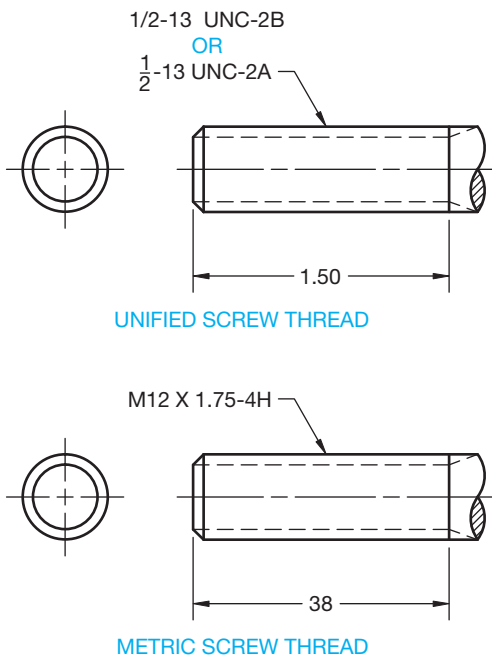


FIGURE 11.36 Drawing and noting external screw threads using a simplified representation.

dimensioned as in Figure 11.37. The dimension given for the length of threads, either directly or with the depth symbol, is the length of full threads, and there can be imperfect threads beyond the dimension, unless otherwise specified.

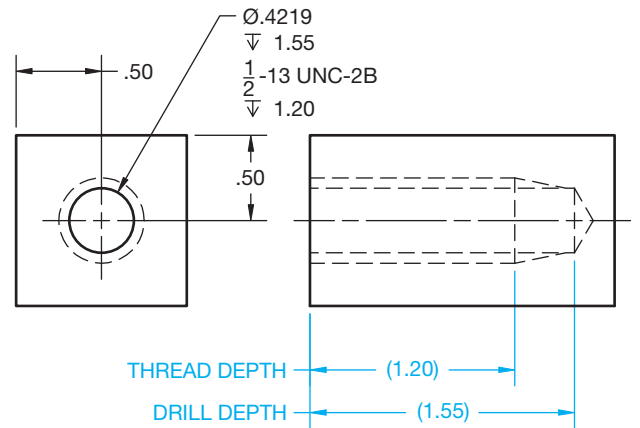
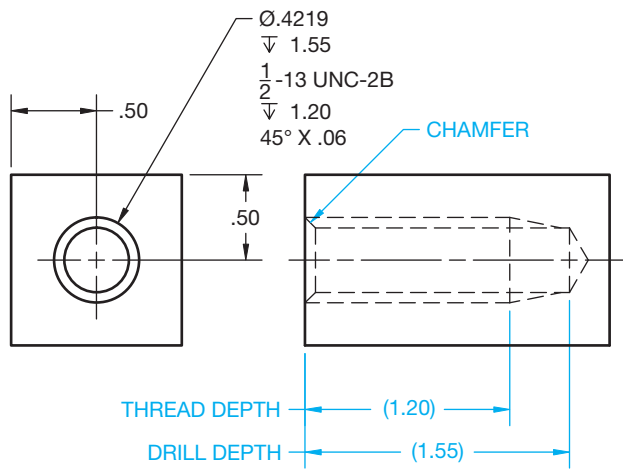


FIGURE 11.38 Showing tap drill depth and thread depth.

Some companies require the drafter to note the complete process required to machine a thread, which includes the tap drill size, tap drill depth if not through, and the thread note and thread depth if not through (see Figure 11.38). A thread chamfer can also be specified in the note as shown in Figure 11.39. Many companies require only the thread note and depth. The complete process is determined in manufacturing.



© Cengage Learning 2012

FIGURE 11.39 Showing tap drill and thread depth with a chamfer.

## MEASURING SCREW THREADS

When measuring features from prototypes or existing parts, the screw thread size can be determined on a fastener or threaded part by measurement. Measure the major diameter with a vernier caliper or micrometer. Determine the number of threads per inch when a rule or scale is the only available tool by counting the number of threads between inch graduations. The quickest and easiest way to determine the thread specification is with a screw pitch gage, which is a set of thin leaves with teeth on the edge of each leaf that correspond to standard thread sections. Each leaf is stamped to show the number of threads per inch. Therefore, if the major diameter measures .625 in. and the number of teeth per inch is 18, then by looking at a thread chart, you find that you have a 5/8-18 UNF thread. Screw thread charts are found in the appendix of this textbook and in the *Machinery's Handbook*.

## THREAD NOTES

CADD makes adding thread information to a drawing quick and accurate. As described throughout this chapter, threads are drawn using specific CADD commands and techniques. CADD tools such as layers and specific commands including COPY, MOVE, OFFSET, ARRAY, and TRIM greatly aid in the process of adding any style of thread representation. In addition to the tools and commands used to draw thread representations, most CADD systems contain specific dimension or annotation options that are very effective for adding thread notes.

A thread note typically attaches to a leader, capped with an arrowhead, that points to the thread representation. Though you can draw thread notes using basic CADD drafting commands such as LINE and TEXT, there are specific tools that quickly and efficiently allow you to produce thread notes complete with a leader. Usually, the leader and thread text is a single editable object. When using AutoCAD, for example, you can create a thread callout using the Multileader, or MLEADER, command. Figure 11.40 shows examples and typical steps used to add a multileader object. A multileader references predefined multileader style settings.

As when creating text objects, most leader and specific note commands include options for formatting the note and adding symbols. For example, if you add the thread note to an internal feature, a variety of symbols can be used to fully describe the hole and desired thread. Some CADD programs offer a general-purpose dimensioning tool or a command specifically for dimensioning circles. When using this type of command, you may have to

replace the diameter value with the proper thread note. Thread notes are a type of dimension, so they are typically drawn using the settings that correspond to the dimension style and layer.

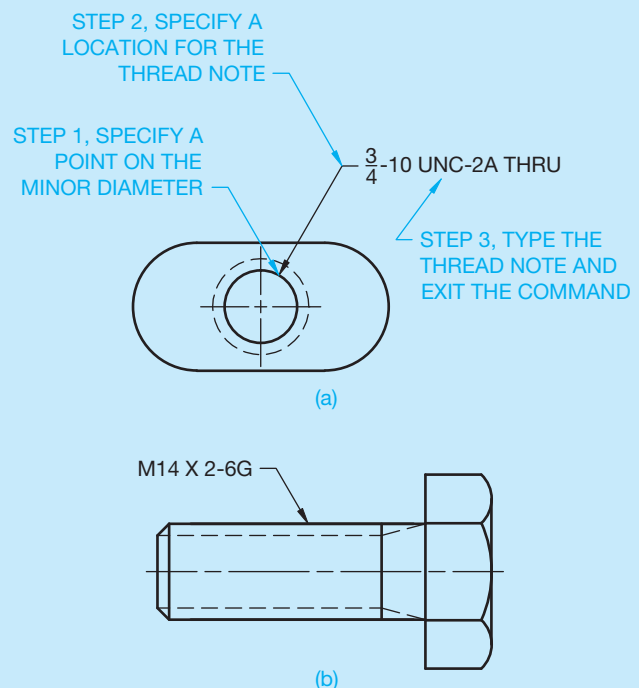


FIGURE 11.40 (a) The typical steps for adding a thread note using the AutoCAD MLEADER command. You can specify the location of the leader shoulder or the note first by selecting the appropriate option. (b) An external thread note. © Cengage Learning 2012

### THREAD REPRESENTATIONS

Typically, you can create threaded model features one of two ways, depending on the CADD system. The first option is to draw a thread profile and, if necessary, the path for the profile to follow and then generate the threaded feature using a tool such as COIL, HELIX, or SWEEP. This technique creates a very realistic 3-D thread representation for applications when a true threaded feature is required (see Figure 11.41).

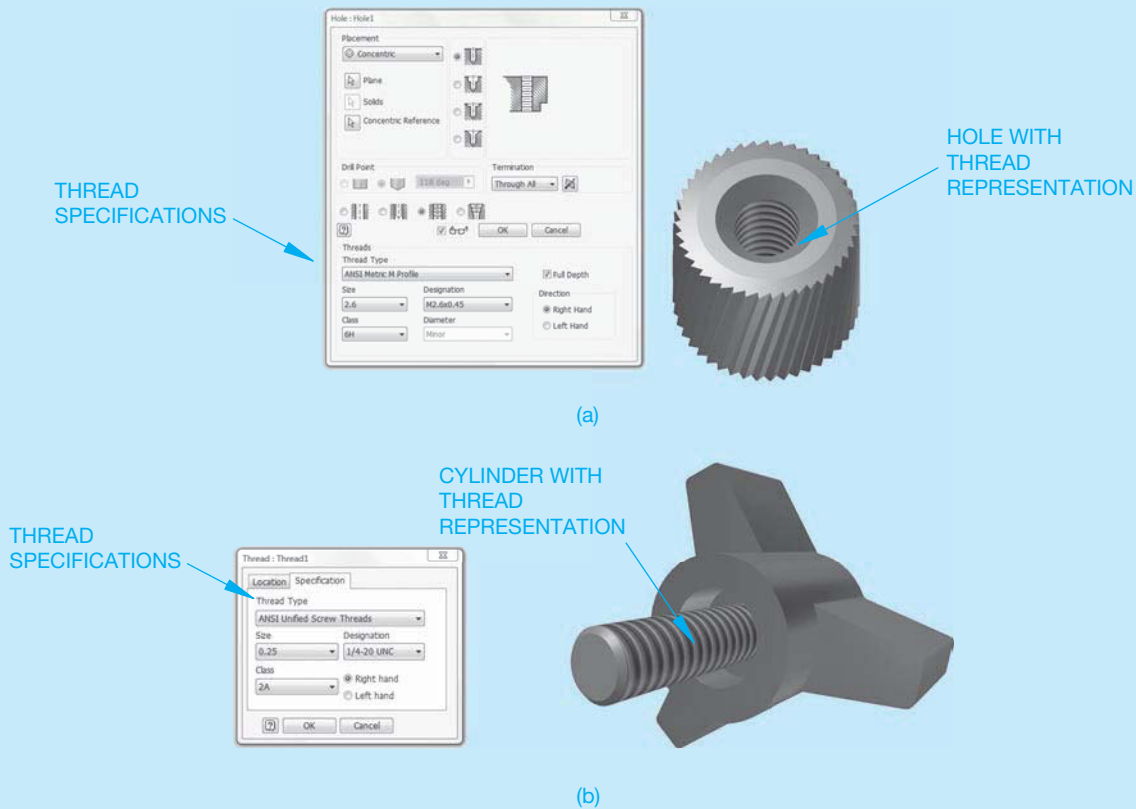
The second option available in some CADD systems involves defining threads by selecting or entering thread specifications but typically not actually creating true thread geometry. This option involves using a tool such as HOLE to add internal thread information or THREADS to describe external threads, depending on the software. Figure 11.42a shows a dialog box used to create a hole and add internal threads. Figure 11.42b shows a dialog box used to add external threads to a cylinder. Notice how all of the thread specifications are entered in the dialog box. Though a real model of threads is not created, the thread characteristics are stored in the file, and you may have the option of displaying an image of threads for representation and visualization purposes, such as the **bitmap** images



© Cengage Learning 2012

**FIGURE 11.41** Examples of solid part models with threads created using a COIL, HELIX, or similar tool.

shown in Figure 11.42. A bitmap is an image of any kind, such as a picture, drawing, text character, or photo, composed of a collection of tiny individual dots.



© Cengage Learning 2012

**FIGURE 11.42** (a) Creating a threaded hole using a HOLES tool. (b) Adding threads to a cylinder using a THREAD tool.

(Continued)

## THREAD NOTES

As described throughout this book, one of the benefits of using a 3-D CADD program that combines 2-D drawing capabilities is the power to dimension a drawing by referencing existing model information. Reference parametric solid model thread specifications in a 2-D drawing using a command such as HOLE CALLOUT or HOLE/THREAD

NOTES. For example, if you create a 1/2-13 UNC-2B hole in a model, the model stores the thread specifications, and it is just a matter of referencing the model thread parameters in the drawing to add a complete thread note (see Figure 11.43). In addition, parametrically drawn thread notes automatically update when changes are made to the specifications of the corresponding model.

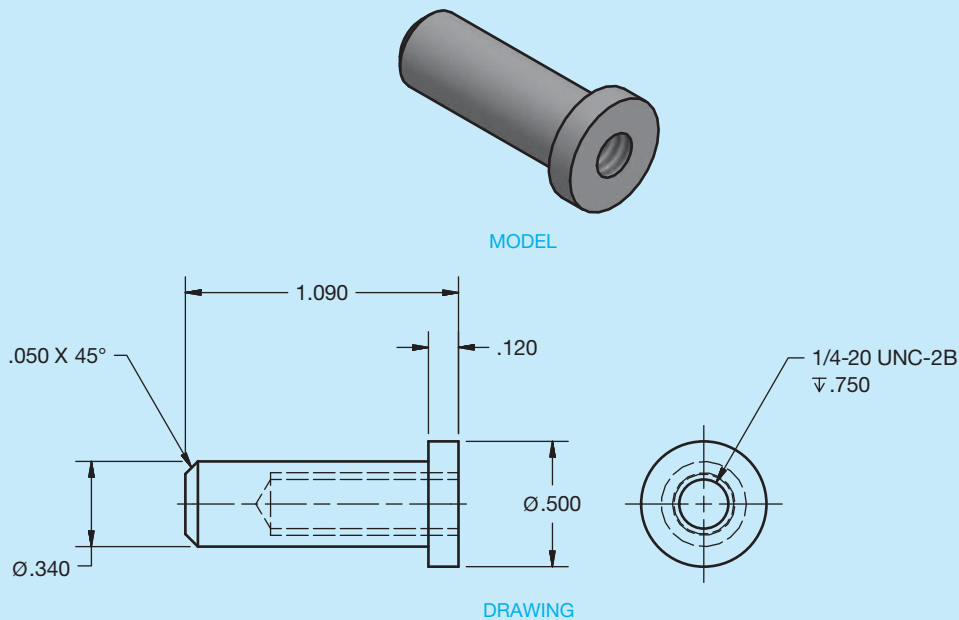


FIGURE 11.43 Adding a thread note to a drawing by referencing existing model parameters.

© Cengage Learning 2012

## THREADED FASTENERS

**Threaded fasteners** are any of the thread forms described in this chapter and manufactured into products that can be used for fastening two or more features or parts together. Threaded fasteners include bolt and nuts, machine screws, cap screws, set screws, and other products. Standard threaded fasteners are identified in the appendixes found in this textbook and in the *Machinery's Handbook*.

### Bolts and Nuts

A **bolt** is a threaded fastener with a head on one end and is designed to hold two or more parts together with a nut or threaded feature. The **nut** is tightened on the bolt or the bolt head can be tightened into a threaded feature. Bolts can be tightened or released by torque applied to the head or the

nut. Bolts are identified by a thread note, length, and head type; for example, 5/8-11 UNC-2 X 1 1/2 LONG HEXAGON HEAD BOLT. Figure 11.44 shows various types of bolt heads. Figure 11.45 shows common types of nuts. Nuts are classified by thread specifications and type. Nuts are available with a flat base or a washer face.

### Machine Screws

**Machine screws** are thread fasteners used for general assembly of machine parts. Machine screws are available in coarse (UNC) and fine (UNF) threads, in diameters ranging from .060 in. to .5 in., and in lengths from 1/8 in. to 3 in. Machine screws are specified by thread, length, and head type. Machine screws have no chamfer on the thread end. There are several types of heads available for machine design flexibility (see Figure 11.46).

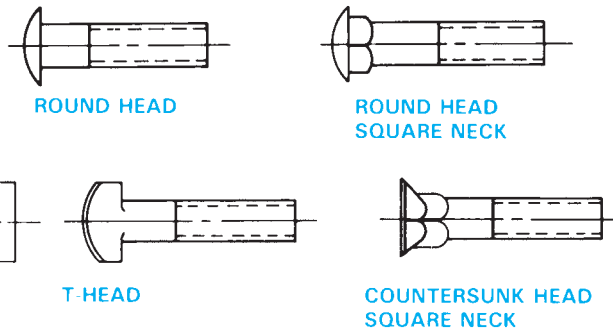
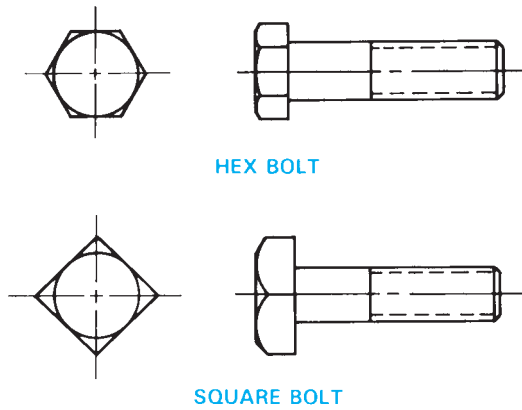


FIGURE 11.44 Bolt head types. © Cengage Learning 2012

### Cap Screws

Cap screws are fine-finished machine screws that are generally used without a nut. Mating parts are fastened where one feature has a through hole for the fastener to pass through and the other feature is threaded to accept the fastener thread. Cap screws have a variety of head types and range in diameter from .060 in. to 4 in. Lengths vary with diameter. For example, lengths increase in 1/16 in. increments for diameters up to 1 in. For diameters larger than 1 in., lengths increase in increments of 1/8 in. or 1/4 in. The other extreme is 2 in. increments for lengths over 10 in. Cap screws have a chamfer to the depth of the first thread. Standard cap screw head types are shown in Figure 11.47.

### Set Screws

Set screws are used to help prevent rotary motion and to transmit power between two parts such as a pulley and shaft. Purchased with or without a head, set screws are ordered by specifying thread, length, head or headless, and type of point. Headless set screws are available slotted and with hex or spline sockets. The shape of a set screw head is usually square. Standard square-head set screws have cup points, although other points are available. Figure 11.48 shows optional types of set screw point styles.

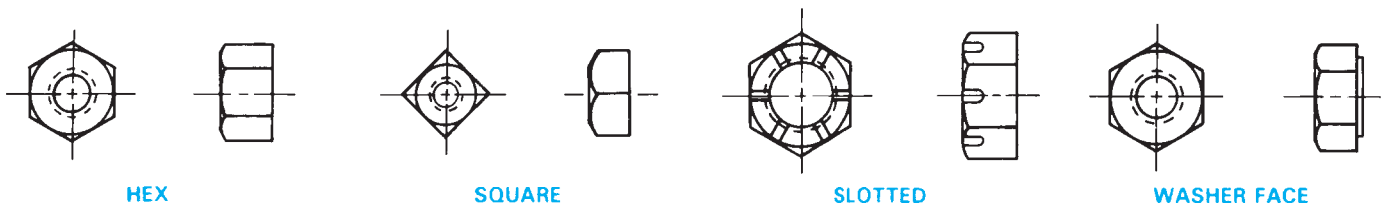


FIGURE 11.45 Types of nuts.

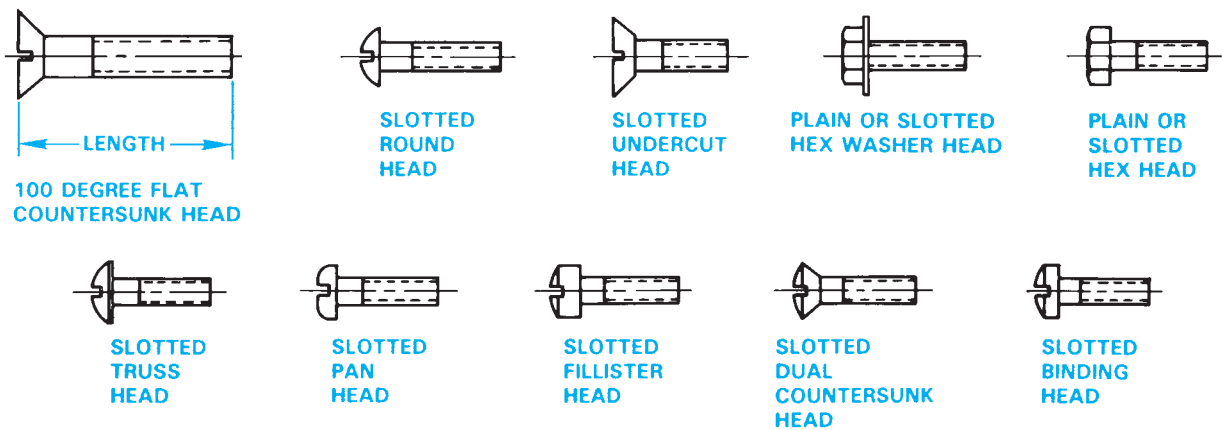


FIGURE 11.46 Types of machine screw heads.



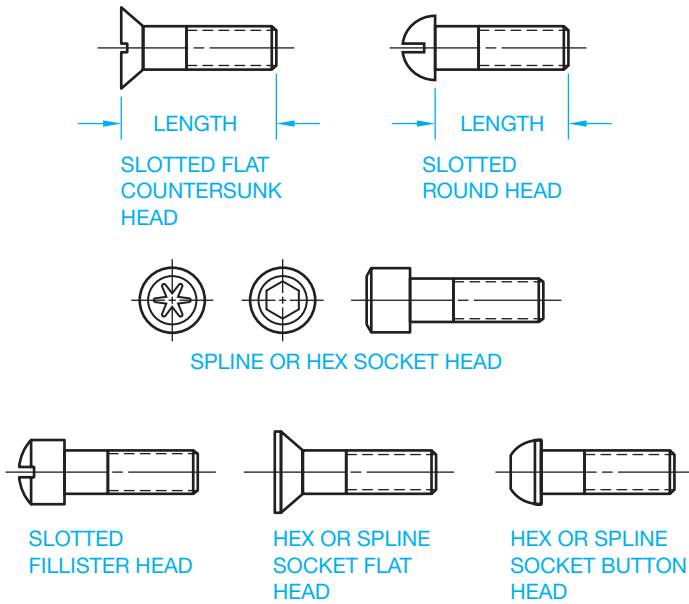


FIGURE 11.47 Cap screw head styles. © Cengage Learning 2012

### THREAD DESIGN GUIDELINES

By Dick Button

The ASME Y14 series of standards includes the ASME Y14.6 and Y14.6aM, *Screw Thread Representation* inch and metric series. Although these standards provide the guidelines for representing threads on the drawing, they do not include design criteria.

The focus of this discussion is to provide design guidelines for threaded features that accommodate manufacturing practices and tooling. Standard thread-forming tools generally have lead-in chamfers that produce two or more incomplete threads on the leading edge of the tool as shown in Figure 11.49. These incomplete threads are called *runout*. Designing features that do not provide enough allowance for runout or sufficient room for the tool affect tool life and reduce the probability of a good thread.

### Designing Threaded Holes

Holes threaded to receive a fastener are produced as either a through hole or a blind hole. Through holes are preferred over blind holes from a manufacturing standpoint. This eliminates

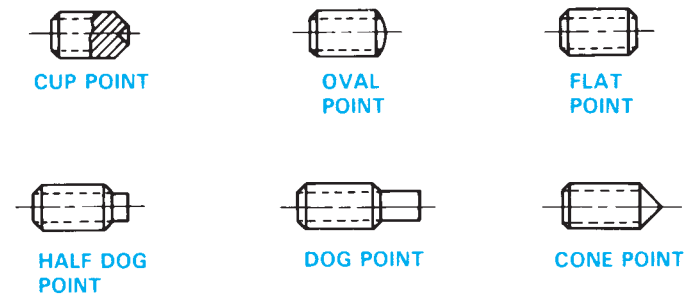
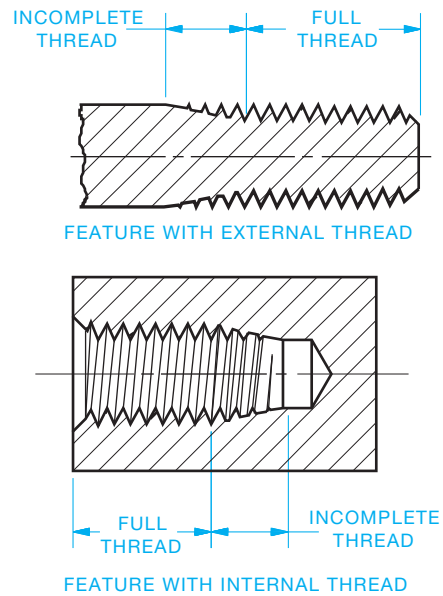


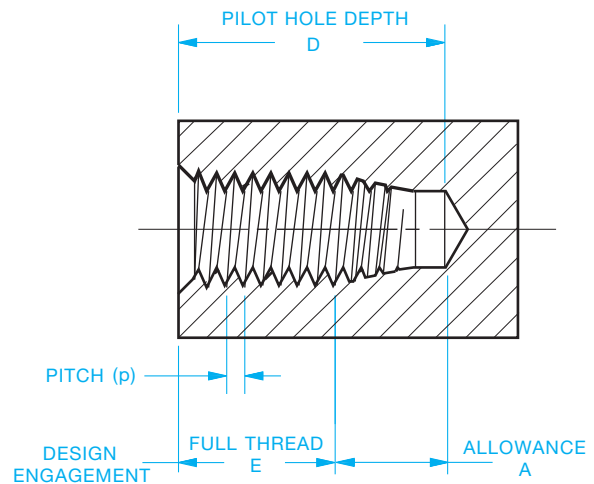
FIGURE 11.48 Set screw point styles. © Cengage Learning 2012



© Cengage Learning 2012

FIGURE 11.49 Standard thread-forming tools generally have lead-in chamfers that produce two or more incomplete threads on the leading edge of the tool.

consideration of incomplete threads, facilitates chip disposal, and allows use of most effective production methods. Unless the thickness of the material to be threaded is considerably greater than the required thread length, or unless design requirements prevent it, the pilot hole (tap drill) for the thread should be drilled through the section. For example, if the total material thickness is equal to or less than the thread depth plus two times the allowance *A* shown in Figure 11.50, then make the feature a through hole.



$$D = E + A$$

$$A = 5p + \text{ADDITIONAL}$$

ADDITIONAL TO BE ESTABLISHED LOCALLY BASED ON EXPERIENCE WITH PARTICULAR MANUFACTURING ENVIRONMENT. CONSIDER 1 TO 2 EXTRA PITCHES.

FIGURE 11.50 Specification for a threading for a blind hole.

© Cengage Learning 2012

A blind hole is a hole that does not go through. If a blind hole is required, the part design should allow the pilot hole to be considerably deeper than the required thread length to maximize machining procedures. There must be an allowance for the chamfer (tap lead) that is greater than the typical lead for the style of threading tool expected to be used. The most common method of producing internal threads is with taps. ASME B94.9 covers designs of ten different types of taps, furnished in taper, plug, or bottoming chamfers. This was introduced earlier in this chapter.

Taper taps generally have lead-in chamfers equal to or greater than ten pitches. They are typically used with through holes in high-speed or high-quantity production applications.

Bottoming taps have lead-in chamfers equal to two pitches. They are used for special applications where through holes are not acceptable and the space is limited for pilot hole allowance. These should be avoided if possible by considering a different design approach. It is difficult to obtain a good start for the tapping process because there is such a short chamfer. In addition, depending on the type of material being machined, bottoming taps may not produce “clean” threads.

Plug taps have lead-in chamfers of 5–7 pitches and are the most commonly used production tool for thread forming. Typical is the cutting tap, but gaining popularity is the cold forming tap. Because cold forming does not remove material and cold work hardens some materials. This method, when done correctly, usually produces a stronger thread.

When determining pilot hole depth, this formula should be a minimum:

$$\text{Pilot hole depth} = \text{Required thread depth} + [5p]$$

where  $p$  is the thread pitch, which is the distance between two thread crests as shown in Figures 11.3 and 11.4. Tap drill sizes are given in Appendix R.

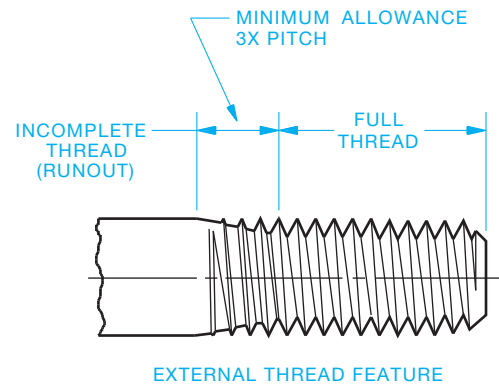
Additional allowance for chips from the machining is beneficial. According to ASME Y14.6, the dimension specified on the drawing for thread depth is to be the minimum measured distance to the last full thread, which means crowding the allowance for chips, tool chamfer, and general machining tolerances could jeopardize the quality of the thread.

A thread chamfer (or countersink) in the pilot hole before tapping helps prevent burrs from the tapping process. A reasonable countersink is a 90° inclusive, .01 to .02 in. (0.2–0.5 mm) larger than the major diameter of the thread.

## Designing External Threads

External threaded features are used with a variety of applications that require considerations for manufacture as well as design function. This discussion deals with the standard unified or metric (M) profile V thread. These are used primarily for fastening and joining.

Just as with the internal thread production, there must be allowance for incomplete threads because of tool runout. Generally, an allowance of three pitch lengths minimum should be used when designing tool runout. **Tool runout** is the distance



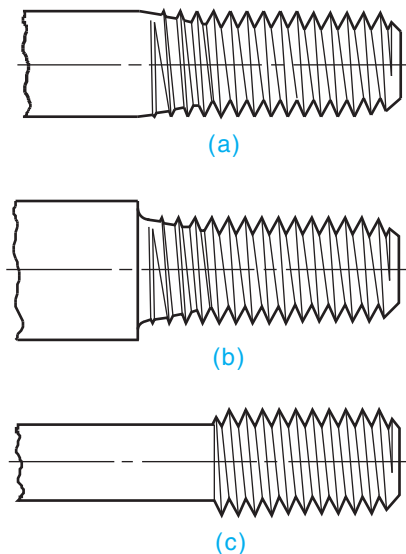
© Cengage Learning 2012

FIGURE 11.51 Tool runout is the incomplete threads that a tool can go beyond the required full thread length.

a tool can go beyond the required full thread length as shown in Figure 11.51. Whenever design permits, this allowance should be increased. If design requirements do not permit the full allowance for standard tools, other possibilities must be investigated with your manufacturing source. For long-term cost-effectiveness of a product, it is better to design around standard tooling.

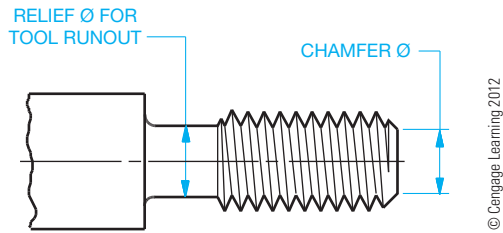
There are three physical possibilities to consider when designing external threaded features:

1. Apply the thread to a straight rod sized to the major diameter of the thread. This includes continuously threaded studs and rods as shown in Figure 11.52a.



© Cengage Learning 2012

FIGURE 11.52 There are three physical properties to consider when designing external threads: (a) Apply the thread to a straight rod sized to the major diameter of the thread. (b) Apply the thread to a feature diameter that is reduced in size from its adjacent feature, creating a shoulder. (c) Apply the thread to a feature diameter that is larger in size than the adjacent feature.

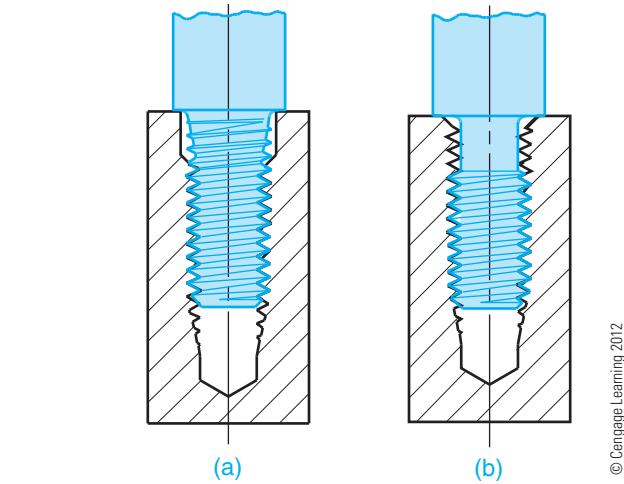


**FIGURE 11.53** If a relief is used to provide room for tool runout, the applied relief diameter should not exceed the minor diameter of the threads.

2. Apply the thread to a feature diameter that is reduced in size from its adjacent feature, creating a shoulder as shown in Figure 11.52b.
3. Apply the thread to a feature diameter that is larger than the adjacent feature (see Figure 11.52c).

External threads should have a lead-in chamfer for tooling. The applied chamfer diameter should not exceed the minor diameter of the thread as indicated in ASME B1.1, *Unified Inch Screw Threads*, or ASME B1.1M, *Metric Screw Thread—M Profile*. If a relief is used to provide room for tool runout, then the applied relief diameter should not exceed the minor diameter of the thread as shown in Figure 11.53. Chamfer and relief calculations and tool runout lengths for drawing application can be made available to designers and drafters by preparing a chart of allowance values to be used for commonly used thread sizes as displayed in Table 11.1. Each design and manufacturing group must determine an acceptable allowance for their environment and product. The design that is applied to large assemblies may not be applicable to small precision products.

When designing a threaded joint with a shoulder, there must be the provision of either a counterbore on the internal threaded feature, as shown in Figure 11.54a, or a relief on the



**FIGURE 11.54** When designing a threaded joint with a shoulder, provide (a) a counterbore on the internal threaded feature or (b) a relief on the external threaded feature.

external threaded feature, as shown in Figure 11.54b, to accommodate the tool runout.

Designs using threads with greater than normal length of engagement require special designations and gaging tolerances to verify the length during the manufacturing process properly. Typical applications are an internal thread in soft material such as plastic or aluminum, where longer engagement is required to increase sheer strength, or a continuously threaded rod used in an assembly for an adjusting mechanism. In either case, binding of the assembly can occur if the special length of thread is not properly noted. For example, if a standard thread gage is used to verify a long external threaded feature, the gage typically covers only 15 pitches. However, if the thread is assembled into a feature that covers greater than 15 pitches, the gage area will not have verified the amount of thread relationship equal to that of the assembly. Normal length of engagement and gaging lengths are defined in ASME B1.1 and B1.13M, Section 5, *Allowances and Tolerances*. Normal length of engagement and full thread length of a threaded feature are not necessarily the same.

**TABLE 11.1** EXAMPLE OF CHART FOR RELIEF OR CHAMFER ALLOWANCE FOR INCH THREADS (USE WITH FIGURE 11.53)

Threads per Inch	For Relief Ø or Chamfer Ø, Subtract from Major Ø
20	.08
18	.08
16	.09
14	.10
13	.11
12	.12
11	.13
10	.14
8	.17

The allowances for this table were created by determining the difference between the maximum major and minor Ø, then adding .02.

### Designing Pipe Threads

Pipe threads appear to be such a simple concept, and yet, depending on the desired function, they can consume many hours of engineering time attempting to define them adequately and manufacturing time trying to get the expected results.

There are three major functions of pipe threads:

1. An assembly that creates a pressure-tight joint, either with a sealer or without a sealer.
2. An assembly with a free or loose-fitting mechanical joint that is not pressure tight.
3. An assembly with a rigid mechanical joint that is not pressure tight.

The assembly with a rigid mechanical joint that is not pressure tight is used for structural purposes such as railings or racks.

The assembly with a free or loose-fitting mechanical joint that is not pressure tight can be used for fixture joints, mechanical joints with locknuts, and hose couplings that have a gasket to seal the joint.

The assembly that creates a pressure-tight joint, either with or without a sealer for pressure-tight joints, can be obtained by these two separate pipe thread types:

- Taper pipe threads for general use, NPT (National Pipe Thread).
- Dryseal pipe threads, NPTF (National Pipe Taper Fuel).

The **dryseal pipe thread** form is called the National Pipe Taper Fuel (NPTF) and called the Dryseal American National Standard Taper Pipe Thread. The dryseal pipe thread form is based on the NPT thread, but with some modifications and greater accuracy of manufacture, it can make a pressure-tight joint without a sealer. General-use NPT threads must have a sealing compound applied to get a pressure-tight joint.

**STANDARDS**

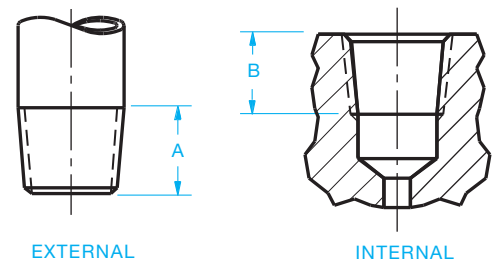
**ASME Inch Series NPT** has wide use throughout the world because of U.S. influence and an increase in the number of piping products and construction projects. There is also the DIN (German) metric pipe thread and the ISO pipe thread that is based on the British Whitworth pipe thread. The ISO pipe thread uses a designation that is similar to the NPT designation, and a few of the sizes appear to assemble with the NPT thread, so be aware of this when dealing with products or manufacturing from other countries.

Taper pipe threads, NPT, are the focus of this discussion. ASME B1.20.1, *Pipe Threads, General Purpose (Inch)*, is the standard for manufacture and gaging of NPT threads. ASME Y14.6, *Screw Thread Representation*, is the standard for presentation and designation on drawings. Figure 11.55 shows recommended methods of representing NPT threads on detail drawings. An introduction to this was provided earlier in this chapter.

The drawing angle for representing the taper of a pipe thread should be 1 1/2° to 2° from the axis of the thread, or a 3 1/2° included angle. The values A and B in Table 11.2 refer to Figure 11.55 and provide a suggested distance on the drawing to represent where the thread ends or the runout of imperfect threads. These dimensions are for drawing representation purposes only and must not be used for manufacture. Do not specify a dimension on the drawing.

When defining the criteria on the drawing for internal threads, two major factors for producing a good thread are the drill diameter and the depth of the pilot hole. There are many published drill guides for pipe thread tapping, and most list a single drill size. The *Machinery's Handbook* is a good

NPT Size	A	B
1/16–27	.38	.31
1/8–27	.38	.31
1/4–18	.58	.50
3/8–18	.61	.50
1/2–14	.78	.62
3/4–14	.78	.62
1–11 1/2	.97	.75
1 1/4–11 1/2	1.00	.75
1 1/2–11 1/2	1.03	.78
2–11 1/2	1.06	.78



**FIGURE 11.55** Recommended methods of representing NPT threads on detail drawings. The dimensions A and B are for reference to Table 11.2 and are not shown on the drawing.

reference. However, various materials require adjustments to the pilot hole size because of differing machining characteristics. A better approach is to specify the pilot hole size on the drawing as a maximum size, then let manufacturing put in a pilot hole size that suits the process. When specifying the depth of the pilot hole, provide clearance for the tap lead that permits cutting into the hole far enough to produce thread for full gaging. Most standard pipe thread taps require at least a seven-pitch lead.

Specify the requirements on the drawing according to the examples in Figure 11.56. The dimensions given in Table 11.3 provide a guideline for values that can be used in dimensioning the pipe thread. These values result from calculations and experience over many years of manufacturing NPT threads on products. These figures and values should not be taken as absolute for every application and process. The production of NPT threads has always been a bit of an art form, and it takes cooperation between engineering and manufacturing at each factory to develop the best criteria.

External NPT threads applied to a feature that has a shoulder similar to the example in Figure 11.56 must have room for the tooling. The part should be designed to provide as much room as possible. Dimension D from Figure 11.57 must be greater than dimension A in Figure 11.55. See the values from Table 11.2 for dimension A.

TABLE 11.3 MAXIMUM HOLE SIZES FOR NPT THREADS

NPT Thread		Produced Hole	Countersink Ø	Dimension C
Size	Pitch	Max Ø	(Tol ± 0.02)	Min
1/16	27	.253	.34	.56
1/8	27	.345	.44	.56
1/4	18	.448	.56	.81
3/8	18	.583	.69	.81
1/2	14	.721	.86	1.06
3/4	14	.931	1.06	1.06
1	11 1/2	1.168	1.34	1.25
1 1/4	11 1/2	1.513	1.69	1.31
1 1/2	11 1/2	1.752	1.91	1.31
2	11 1/2	2.226	2.38	1.31

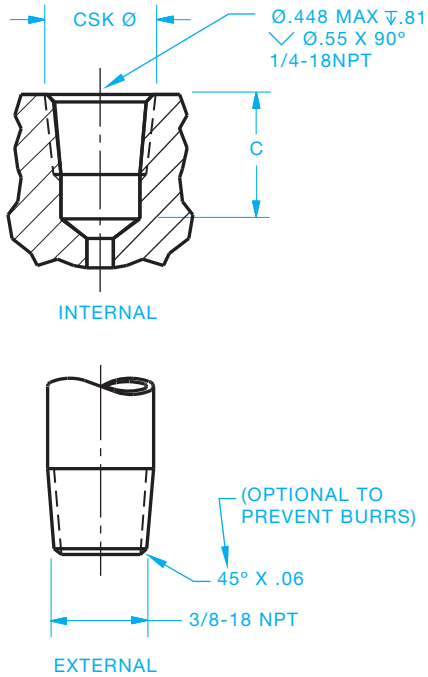


FIGURE 11.56 Methods for showing NPT thread specification on a drawing.

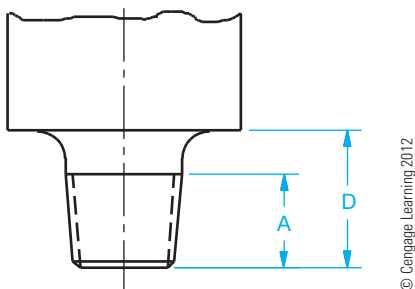


FIGURE 11.57 Applying an NPT thread to a feature that has a shoulder. Dimension D must be greater than dimension A, which is found in Table 11.2. These dimensions are for reference only and are not displayed on the drawing.

In the process of manufacturing taper pipe threads, several considerations for producing a good joint are:

- Pilot holes that are round.
- Minimal waviness on produced thread, both internal and external. Watch tool alignment.
- Full crests for at least the first three internal threads.
- L1 gaging that goes deep instead of shallow. L1 is a gaging member that effectively checks the functional conformance of the threads.
- Proper installation torque. Too much torque can be damaging.

### LAG SCREWS AND WOOD SCREWS

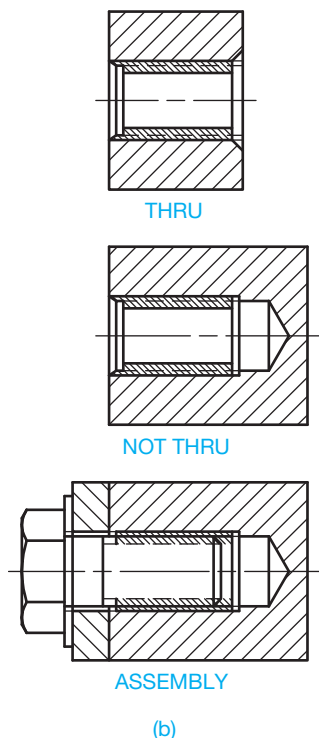
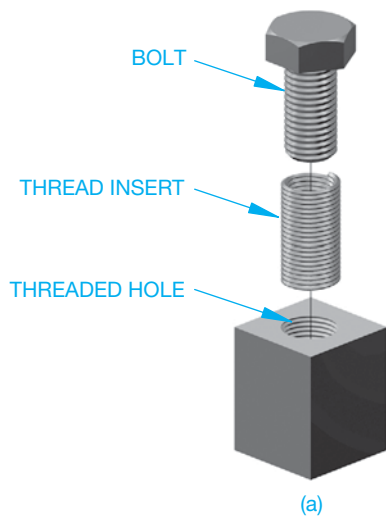
Lag screws are designed to attach metal to wood or wood to wood. Before assembly with a lag screw, a pilot hole is cut into the wood. The threads of the lag screw then form their own mating thread in the wood. Lag screws are sized by diameter and length. Wood screws are similar in function to lag screws and are available in a wide variety of sizes, head styles, and materials.

### SELF-TAPPING SCREWS

Self-tapping screws are designed for use in situations where the mating thread is created by the fastener. These screws are used to hold two or more mating parts when one of the parts becomes a fastening device. A clearance fit is required through the first series of features or parts while the last feature receives a pilot hole similar to a tap drill for unified threads. The self-tapping screw then forms its own threads by cutting or displacing material as it enters the pilot hole. There are several different types of self-tapping screws with head variations similar to cap screws. The specific function of the screw is important because these screws may be designed for applications ranging from sheet metal to hard metal fastening.

## THREAD INSERTS

**Screw thread inserts** are helically formed coils of diamond-shaped wire made of stainless steel or phosphor bronze. The inserts are used by being screwed into a threaded hole to form a mating internal thread for a threaded fastener. Inserts are used to repair worn or damaged internal threads and to provide a strong thread surface in soft materials. Some screw thread inserts are designed to provide a secure mating of fasteners in situations where vibration or movement could cause parts to loosen. Figure 11.58 shows the relationship among the fastener, thread insert, and tapped hole.



© Cengage Learning 2012

**FIGURE 11.58** (a) Threaded insert. (b) The simplified representation for threaded insert applications.

## SELF-CLINCHING FASTENERS

A **self-clinching fastener** is any device, usually threaded, that displaces the material around a mounting hole when pressed into a properly sized drilled or punched hole. This pressing or squeezing process causes the displaced sheet material to cold flow into a specially designed annular recess in the shank or pilot of the fastener. A serrated clinching ring, knurl, ribs, or hex head prevents the fastener from rotating in the metal when tightening torque is applied to the mating screw or nut. When properly installed, self-clinching fasteners become a permanent and integral part of the panel, chassis, bracket, printed circuit board, or other item in which they are installed. They meet high-performance standards and can allow for easier disassembly of components for repair or service.

Self-clinching fasteners generally take less space and require fewer assembly operations than caged and other types of locking nuts. They also have greater reusability and more holding power than sheet metal screws. They are used mainly where good pullout and torque loads are required in sheet metal that is too thin to provide secure fastening by any other method.

Self-clinching fasteners traditionally fall into the categories of nuts, spacers and standoffs, and studs.

### Self-Clinching Nuts

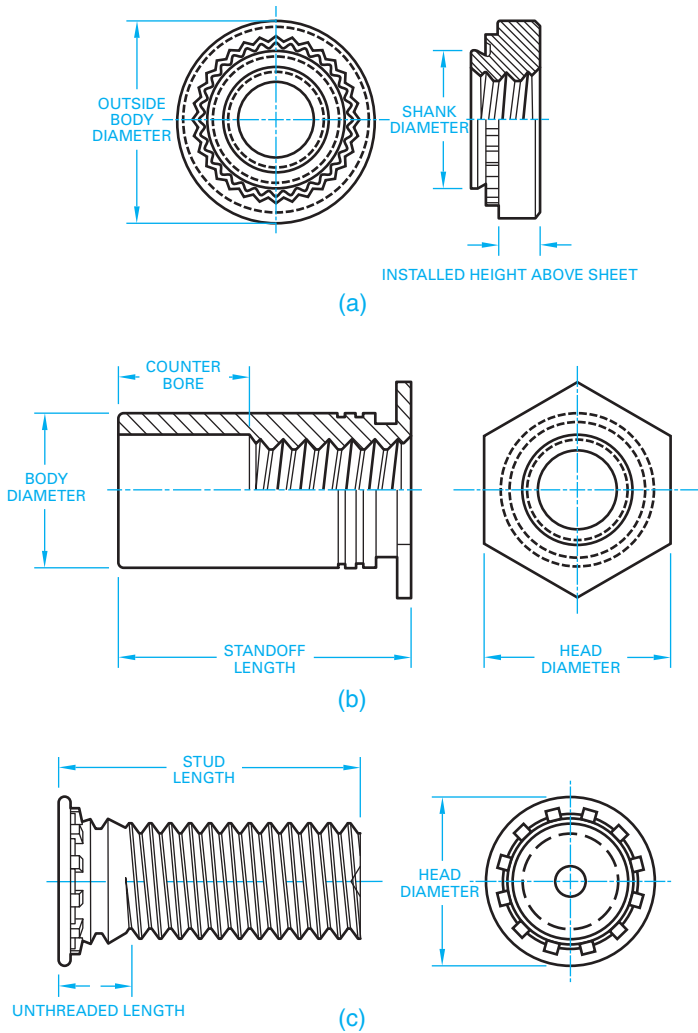
**Self-clinching nuts** feature thread strengths greater than those of mild screws and are commonly used wherever strong internal threads are needed for component attachment or fabrication assembly. During installation, a clinching ring locks the displaced metal behind the fastener's tapered shank, resulting in a high push-out resistance. High torque-out resistance is achieved when the knurled platform is embedded in the sheet metal. The clinching action of self-clinching nuts occurs on the fastener side of the thin sheet, with the reverse side remaining flush. A self-clinching nut is shown in Figure 11.59a.

### Self-Clinching Spacers and Standoffs

**Self-clinching spacers** and **standoffs** are used where it is necessary to space or stack components away from a panel. Thru-threaded or blind types are generally standard, but variations have been developed to meet emerging applications, primarily in the electronics industry. These types include standoffs with concealed heads, others that allow boards to snap into place for easier assembly and removal, and those designed specifically for use in printed circuit boards. Figure 11.59b shows an example of a self-clinching standoff.

### Self-Clinching Studs

**Self-clinching studs** are externally threaded self-clinching fasteners that are used where the attachment must be positioned



**FIGURE 11.59** PEM® self-clinching fasteners: (a) A self-clinching nut. (b) A self-clinching standoff. (c) A self-clinching stud. Courtesy of Penn Engineering & Manufacturing Corp. and Hammer Inc., Advertising & Public Relations

before being fastened. Flush-head studs are normally specified, but variations are available for desired high torque, thin sheet metal, or electrical applications. Figure 11.59c shows a self-clinching stud.

### HOW TO DRAW VARIOUS TYPES OF SCREW HEADS

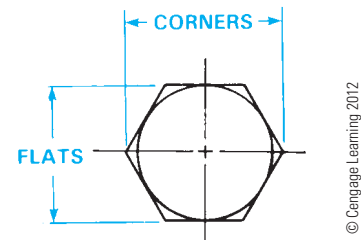
As you have found from the previous discussion, screw fasteners are classified, in part, by head type, and there is a large variety of head styles. A valuable drafting reference is the *Machinery's Handbook*, which clearly lists specifications and drawing details for all common head types.

### Hexagon Head Fasteners

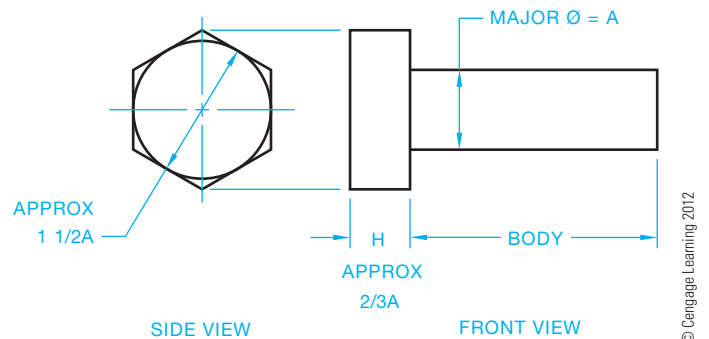
Hexagon head fasteners are generally drawn with the hexagon positioned across the corners vertically in the front view.

Hexagon head fasteners and nuts are often referred to as **hex**. When projected across the flats, the hex head looks like a square head, which is a poor view to use when representing a hexagon. The following steps show how to draw a hex head bolt. Hex nuts are drawn in the same manner:

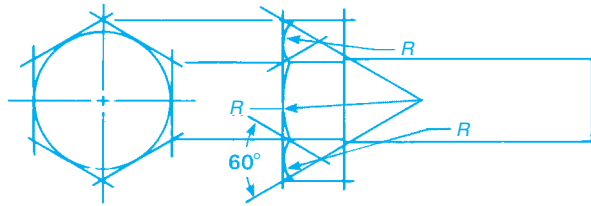
- STEP 1** Use construction lines to draw the end view of the hexagon using the distance across the flats as the construction information. Refer to Chapter 7, *Drafting Geometry*, if necessary. Do all construction on a construction layer. The distance across the flats is calculated using the formula  $1 \frac{1}{2}A$  (1.5A), where  $A = \frac{3}{4}$  (.75). Calculation:  $1.5 \times .75 = 1.125$ . This calculation determines that a  $\frac{3}{4}$  in. nominal thread diameter has  $\frac{1}{8}$  in. across the flats. This can also be determined by looking at a hexagon head bolt chart. Position the bolt head so a front-view projection is across the corners as shown in Figure 11.60.
- STEP 2** Block out the major diameter and length, and bolt head height. The same  $\frac{3}{4}$  in. hex bolt has a head height  $H$ , which is calculated as  $\frac{2}{3}A$ , where  $A = \frac{3}{4}$  (.75).  $\frac{2}{3} \times .75 = .5$  in. (see Figure 11.61).
- STEP 3** Project the hexagon corners to the front view. Then establish radii  $R$  with centers established using the  $60^\circ$  angles as shown in Figure 11.62. Draw the radii.
- STEP 4** Complete the head by drawing a  $30^\circ$  chamfer tangent on each side to the small radius arcs. Use object lines to complete both views. Draw a vertical object line to extent of the thread length on the body. This is determined



**FIGURE 11.60** Step 1: Draw a hexagon given the flats and corner of a hexagon.

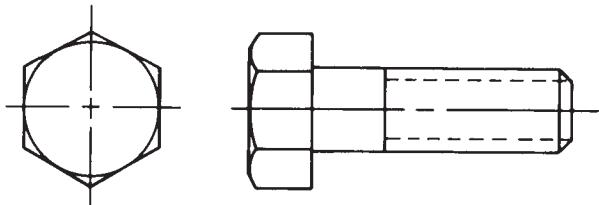


**FIGURE 11.61** Step 2: Layout two views using construction lines.



© Cengage Learning 2012

FIGURE 11.62 Step 3: Layout the hex head.



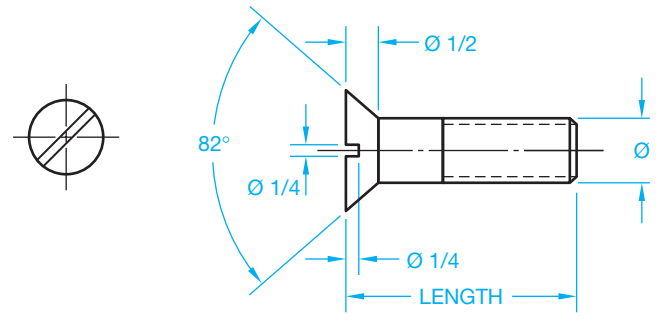
© Cengage Learning 2012

FIGURE 11.63 Step 4: The finished drawing of a hex head fastener using simplified thread representation.

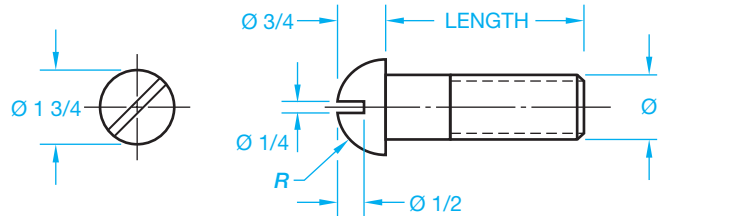
by looking at a hex head bolt chart and referring to the specific size bolt used. Make the thread length about 2/3 of the body length for this drawing. Draw the thread representation using hidden lines as described earlier in this chapter. Draw a 45° chamfer at the thread end (see Figure 11.63).

A CADD system can quickly and accurately draw bolt heads, screw heads, and nuts. The commonly used commands include LINE, ARC, CIRCLE, and POLYGON. The fastener heads are commonly constructed from a series of lines, arcs, circles, and polygons. A common polygon is the hexagon, which creates the hex head bolt or screw, and the nut. The different types of fasteners can be created as blocks and then inserted and scaled into the drawing as needed. This practice saves a great deal of time. Special applications software is also available for inserting fasteners into the drawing. Your 2-D CADD program can be used to draw hex head fasteners using the steps described. Use a construction layer that can be turned off or frozen when finished. Use a command such as TRIM to clean up overrun lines. Use a command such as CHAMFER to draw the chamfer at the thread end. When using a 3-D modeling program, you can create the 2-D views of the hex head bolt by selecting the desired views. For example, you can select a front and left side view as shown in Figure 11.63. You can also display a 3-D view in the corner of the sheet for visualization purposes.

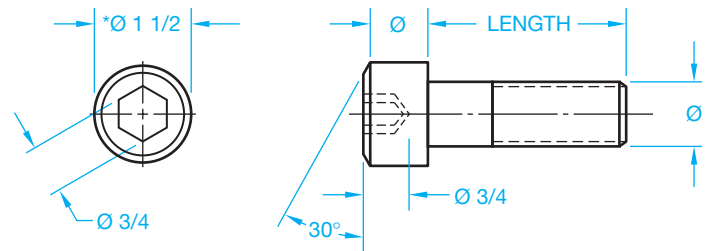
Square-head bolts are drawn in the same manner as hex-head bolts. Refer to Chapter 7, *Drafting Geometry*, for instructions and examples on drawing square and hexagonal shapes. Use the appendixes in this textbook or the *Machinery's Handbook* for specific dimensions related to the fastener head type you are drawing.



FLAT HEAD CAP SCREW



ROUND HEAD CAP SCREW



HEX SOCKET HEAD CAP SCREW

FIGURE 11.64 Layout specification for common cap screws. \*For metric screw sizes, the ratio of screw diameter to head diameter is 1.5 for 12 mm and above, but for sized 3 mm to 10 mm it is 1.5 times plus 1 mm. Consult the *Machinery's Handbook* for sizes 2 mm and smaller. © Cengage Learning 2012

## Cap Screws

Figure 11.64 shows a few common cap screw heads with approximate layout dimensions.

## DRAWING NUTS

A **nut** is used as a fastening device in combination with a bolt to hold two or more pieces of material together. The nut thread must match the bolt thread for acceptable mating. Figure 11.65 shows the nut and bolt relationship. The hole in the parts must be drilled larger than the bolt for clearance.

There are varieties of nuts in hexagon or square shapes. Nuts are also designed as slotted to allow them to be secured with a pin or key. Acorn nuts are capped for appearance so the bolt thread is concealed. Self-locking nuts are available with nylon inserts that help keep the nut tight when movement or vibration is a factor. Figure 11.66 shows some common nuts.



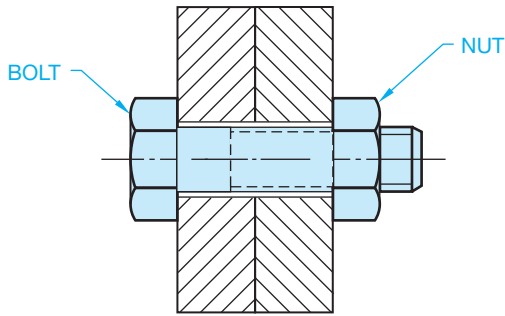


FIGURE 11.65 Nut and bolt relationship known as a floating fastener.

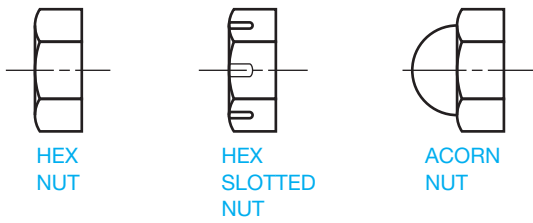


FIGURE 11.66 Common nuts.

Hex nuts are drawn in a manner similar to the method used to draw hex head fasteners shown in Figures 11.60 through 11.63. Use the appendixes in this textbook or the *Machinery's Handbook* to get specific dimensions and information for the specific hex nut you are drawing. Square nuts and other types of fasteners are also detailed in the textbook appendixes the *Machinery's Handbook* for your reference.

### DRAWING WASHERS

Washers are flat, disc-shaped objects with a center hole to allow a fastener to pass through. Washers are made of metal, plastic, or other materials for use under a nut or bolt head, or at other machinery wear points, to serve as a cushion or a bearing surface, to prevent leakage, to relieve friction, or as a fastener locking device (see Figure 11.67). Washer thickness varies from .016 in. to .633 in. Refer to the appendixes in this textbook or to the *Machinery's Handbook* for washer tables with sizes and specifications.

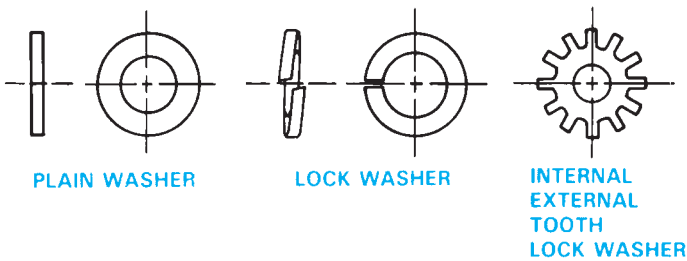


FIGURE 11.67 Types of washers. © Cengage Learning 2012

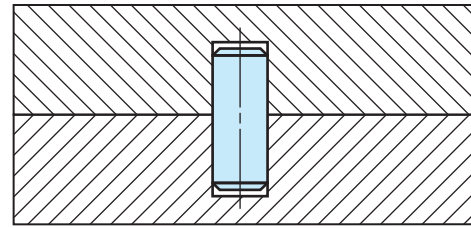
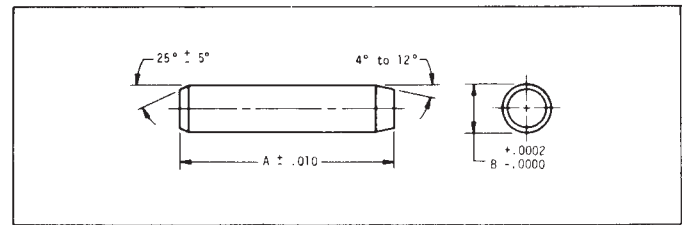


FIGURE 11.68 Dowel pin in place, sectional view.

### DOWEL PINS

HARDENED-PRESS FIT

1/16 TO 3/8 DIAMETERS  
3/16 TO 1-1/2 LENGTHS



Material: 416 Stainless Steel (Clear Passivate) Hardened to: Rockwell C 36-40  
Conforms to specification MS-16555  
For 303 stainless pins, please see Cat. No. EPS-A1 and EPS-B1

	1/16 DIA. PIN B = .0626		3/32 DIA. PIN B = .0938		1/8 DIA. PIN B = .1251		5/32 DIA. PIN B = .1563	
A	Cat. No.	Price	Cat. No.	Price	Cat. No.	Price	Cat. No.	Price
3/16	EPS-D1-1	\$.09	*EPS-D2-1	\$.14	-	-	-	-
1/4	EPS-D1-2	.09	*EPS-D2-2	.15	*EPS-D3-2	\$.14	-	-
5/16	EPS-D1-3	.10	EPS-D2-3	.11	*EPS-D3-3	.15	-	-
3/8	EPS-D1-4	.10	EPS-D2-4	.11	EPS-D3-4	.13	*EPS-D4-4	\$.17
7/16	EPS-D1-5	.10	EPS-D2-5	.11	EPS-D3-5	.13	*EPS-D4-5	.17
1/2	EPS-D1-6	.11	EPS-D2-6	.11	EPS-D3-6	.13	EPS-D4-6	.17

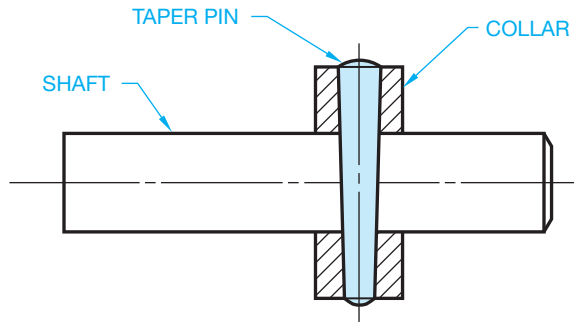
FIGURE 11.69 Dowel pin chart drawing. Courtesy Nordex, Inc.

### DRAWING DOWEL PINS

Dowel pins used in machine fabrication are metal cylindrical fasteners that retain parts in a fixed position or keep parts aligned. Generally, depending on the function of the parts, one or two dowel pins are enough for holding adjacent parts. Dowel pins must generally be pressed into a hole with an interference tolerance of between .0002 in. and .001 in., depending on the material and the function of the parts. Figure 11.68 shows the section of two adjacent parts and a dowel pin application. Figure 11.69 is a chart drawing of some standard dowel pins. Chart drawings were introduced in Chapter 10.

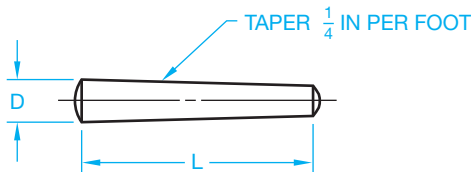
### TAPER PINS AND OTHER PINS

For applications that require perfect alignment of accurately constructed parts, tapered dowel pins can be better than straight dowel pins. Taper pins are also used for parts that have to be taken apart frequently or where removal of straight dowel



© Cengage Learning 2012

FIGURE 11.70 Taper pin in assembly, sectional view.



© Cengage Learning 2012

FIGURE 11.71 Taper pin.

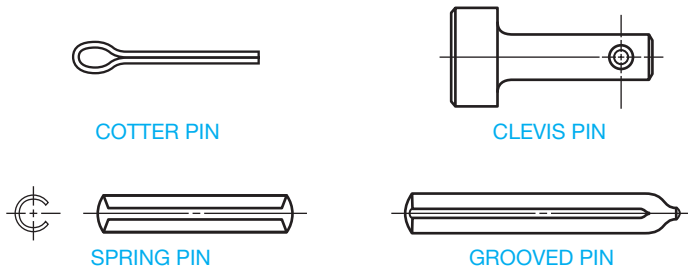


FIGURE 11.72 Other common pins. © Cengage Learning 2012

pins can cause excess hole wear. Figure 11.70 shows an example of a taper pin assembly. Taper pins, shown in Figure 11.71, range in diameter,  $D$ , from  $7/8$ , which is .0625 in. to .875 in., and lengths,  $L$ , vary from .375 in. to 8 in.

Other types of pins serve functions similar to taper pins, such as holding parts together, aligning parts, locking parts, and transmitting power from one feature to another. Figure 11.72 shows other common pins.

## RETAINING RINGS

Internal and external retaining rings are available as fasteners to provide a stop or shoulder for holding bearings or other parts on a shaft. They are also used internally to hold a cylindrical feature in a housing. Common retaining rings require a groove in the shaft or housing for mounting with a special pliers tool. Also available are self-locking retaining rings for certain applications (see Figure 11.73).

## KEYS, KEYWAYS, AND KEYSEATS

Standards for keys were established to control the relationship among key sizes, shaft sizes, and tolerances for key applications. A key is an important machine element, which is used to provide a positive connection for transmitting torque between a shaft and hub, pulley, or wheels. The key is placed in position in a keyseat, which is a groove or channel cut in a shaft. The shaft and key are then inserted into the hub, wheel, or pulley, where the key mates with a groove called a keyway. Figure 11.74 shows the relationship among the key, keyseat, keyway, shaft, and hub.

### Determining Key, Keyway, and Keyseat Dimensions

Standard key sizes are determined by shaft diameter. For example, shaft diameters ranging from  $7/8$  in. to  $1\ 1/4$  in. require a  $1/4$  in. nominal width key. Keyseat depth dimensions are established in relationship to the shaft diameter. Figure 11.75a shows the standard dimensions for the related features. For a shaft with a  $3/4$  in. diameter, the recommended shaft dimension,  $S$ , is .676 in. and the hub dimension,  $T$ , is .806 in. when using a parallel rectangular key. Refer to this dimensional information in the Key Sizes Versus Shaft Diameter table in Appendix Q and in the *Machinery's Handbook*. Figure 11.75b shows the drawing of a shaft and hub using the example  $3/4$  in. diameter shaft and a parallel rectangular key.

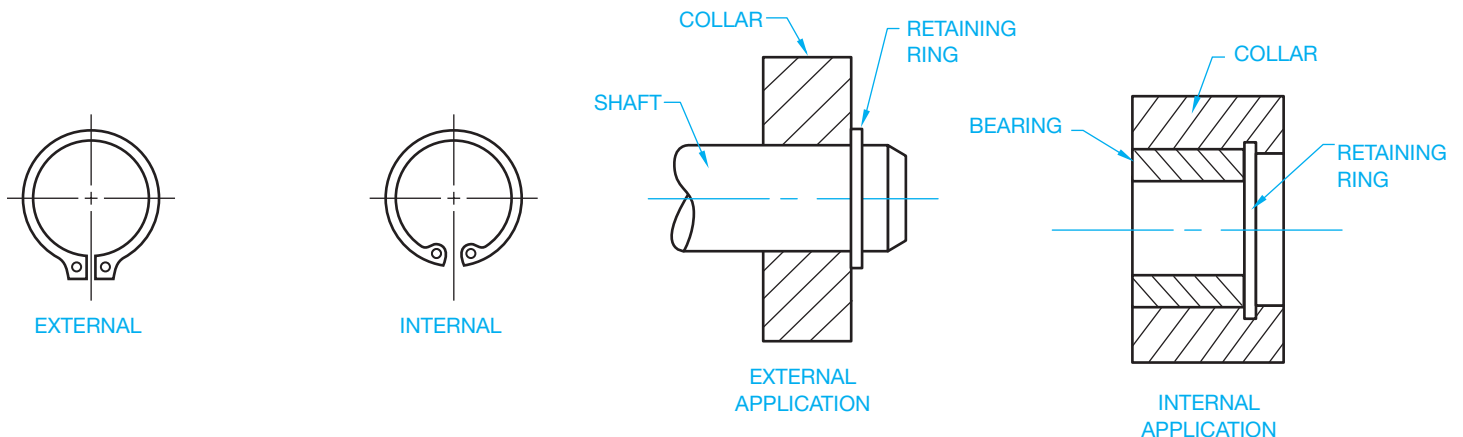


FIGURE 11.73 Retaining rings. © Cengage Learning 2012

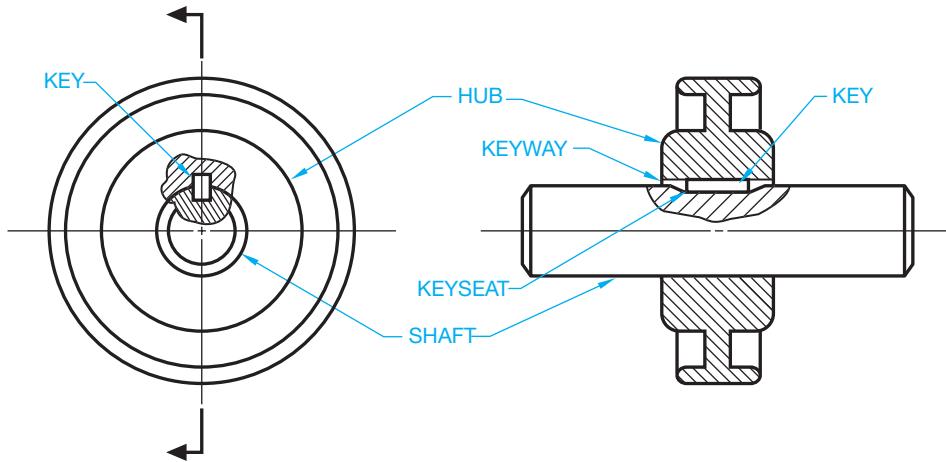


FIGURE 11.74 Relationship between the key, keyseat, keyway, shaft, and hub.

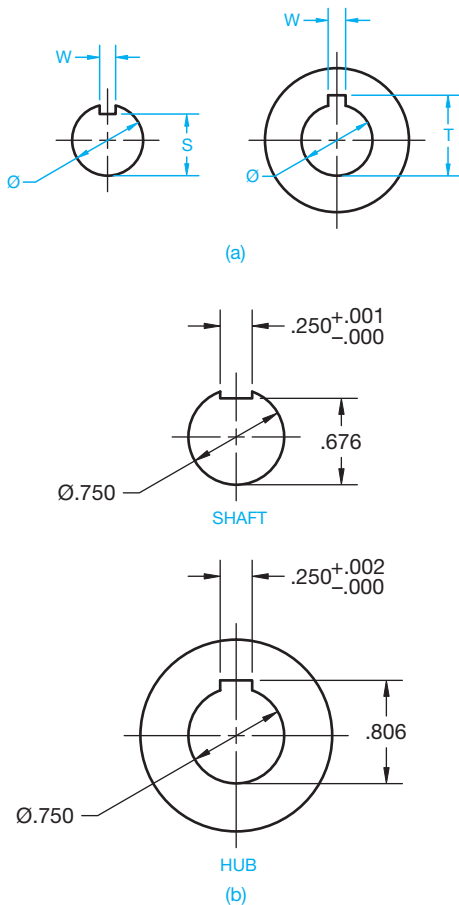


FIGURE 11.75 (a) Keyseats and keyways are generally sized as related to shaft size. S, T, and W are dimensions typically found in keyseat and keyway data. (b) A shaft and hub dimensioned drawing.

The width of the keyway and keyseat, W in Figure 11.75b, is determined by the width of the key used and the tolerance needed for the key to fit in the keyway and keyseat. Look at

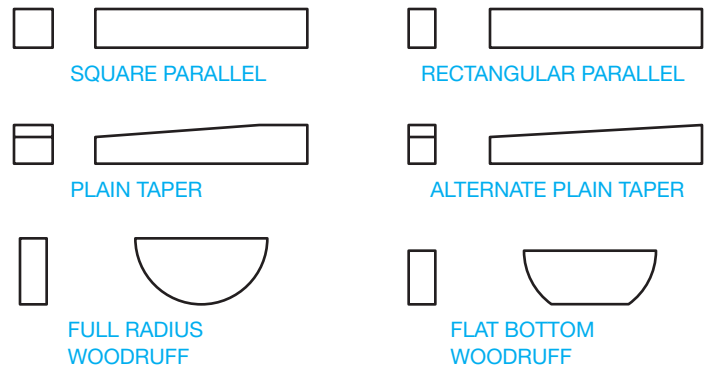


FIGURE 11.76 Types of keys. © Cengage Learning 2012

the Fit for Parallel and Taper Keys table found in Appendix Q or in the *Machinery's Handbook* for this information. The width tolerance for the example 1/4 in. nominal width key is  $+.001-.000$  for the keyseat, and  $+.002-.000$  for the keyway. Using the 1/4 in. nominal width key, convert the fraction value 1/4 to a decimal value of .250. Now, apply the tolerance for the keyseat width dimension of  $.250+.001-.000$  and the keyway width dimension of  $.250+.002-.000$  (see Figure 11.75b).

Appendix Q and the *Machinery's Handbook* provide key and keyseat specifications. Figure 11.76 shows types of keys.

## RIVETS

A **rivet** is a metal pin with a head used to fasten two or more materials together. The rivet is placed through holes in mating parts and the end without a head extends through the parts to be **headed-over** by hammering, pressing, or forging. Headed-over means formed into a head. The end with the head is held in place with a solid steel bar known as a *dolly* while a head is formed on the other end. Rivets are classified by body diameter, length, and head type (see Figure 11.77).

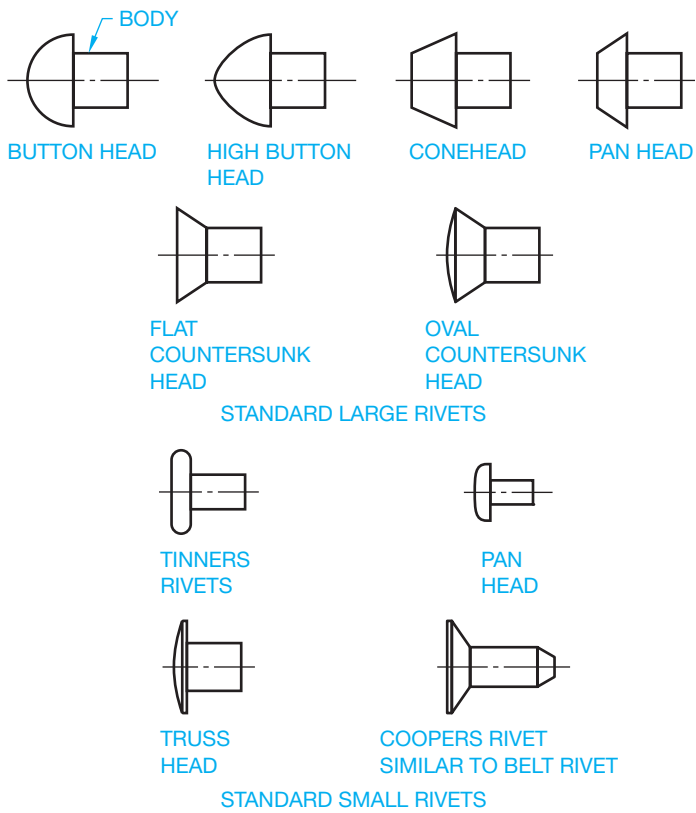


FIGURE 11.77 Common rivets. © Cengage Learning 2012

## DESIGNING AND DRAWING SPRINGS

A **spring** is a mechanical device, often in the form of a helical coil that yields by expansion or contraction due to applied pressure, force, or stress. A **mechanical spring** is defined by ASME as an elastic body whose mechanical function is to store energy when deflected by a force and to return the equivalent amount of energy on being released. Springs are made to return to their normal form when the force or stress is removed. Springs are designed to store energy for the purpose of pushing or pulling machine parts by reflex action into certain desired positions. Improved spring technology provides springs with the ability to function for a long time under high stresses. The effective use of springs in machine design depends on five basic criteria, including: material, application, functional stresses, use, and tolerances.

Continued research and development of spring materials have helped to improve spring technology. The spring materials most commonly used include high-carbon spring steels, alloy spring steels, stainless spring steels, music wire, oil-tempered steel, copper-based alloys, and nickel-based alloys. Depending on use, spring materials may have to withstand high operating temperatures and high stresses under repeated loading.

Spring design criteria are generally based on material gage, kind of material, spring index, direction of the helix, type of ends, and function. Spring wire gages are available from

### FASTENER SYMBOL LIBRARIES

One of the most powerful features of CADD software is the ability to reuse drawing and model content. This is especially true when designing and drafting products that contain fasteners. Often fasteners are standard parts that are used multiple times for several different projects. As a result, creating or purchasing a library of fasteners can prove very beneficial. As shown in this chapter, many fasteners contain complex shapes, especially if drawing threaded fasteners that require the use of detailed thread representations. Reusing existing fasteners and using fastener symbol libraries can save a significant amount of time and allow designers and drafters to focus on the design and documentation of a product instead of the task of creating individual fasteners using basic drawing tools.

Figure 11.78 shows an example of symbols found in a 2-D fastener library. This particular library contains several commonly used fasteners that can be added to a specific drawing view in the form of a symbol. Once you insert the base symbol, you have the option to

Image not available due to copyright restrictions

Text not available due to copyright restrictions

(Continued)

create a unique fastener by editing the size and shape of the symbol. For example, you may want to adjust the length of a bolt. Many of these CADD library applications allow you to dynamically adjust the diameter, length, and thread specification and add the proper thread note.

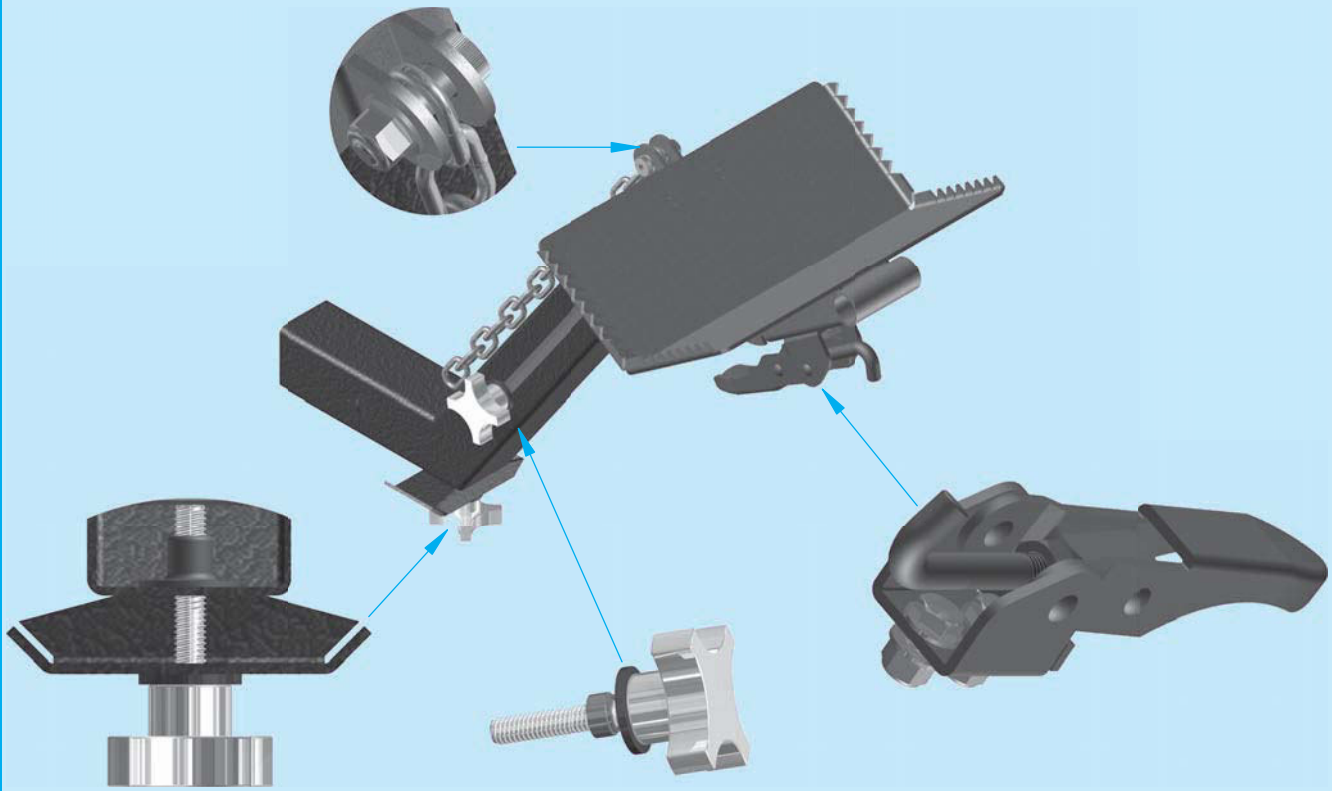
### FASTENER TOOLS

Some CADD programs and specialized fastener software systems make the process of adding fasteners to drawings and models quick and easy. Instead of drawing and creating fasteners, or even picking fasteners from a symbol library, some CADD systems allow you to select fastener variables and automatically generate a fastener based on those specifications. CADD fastener software

allows you to select the following variables, depending on the particular program:

- Type of bolt or screw.
- Type of head, if any.
- Type and location of washers, if used.
- Threading of holes or studs.
- Type of thread representation.
- Type of nut, if used.

After selecting these variables, you typically choose a location to place the fastener. Then using parametrics based on your specifications, a drawing or model of the fastener is automatically created. Figure 11.79 shows an example of fasteners added to an assembly using a CADD software fastener generator.



Courtesy 2-Kool Inc.

**FIGURE 11.79** An example of using a specialized CADD software fastener tool to create complete fasteners. Some components are hidden in the view enlargements to show the complete fasteners.

several different sources ranging in diameter from number 7/0 (.490 in.) to number 80 (.013 in.). The most commonly used spring gages range from 4/0 to 40. There are varieties of spring materials available in round or square stock for use depending on spring function and design stresses.

The **spring index** is a ratio of the average coil diameter to the wire diameter. The index is a factor in determining spring stress,

deflection, and the evaluation of the number of coils needed and the spring diameter. Recommended index ratios range between 7 and 9, although other ratios commonly used range from 4 to 16. The direction of the helix is a design factor when springs must operate in conjunction with threads or with one spring inside of another. In such situations, the helix of one feature should be in the opposite direction of the helix for the other feature.



© Cengage Learning 2012

FIGURE 11.80 Compression and extension spring.

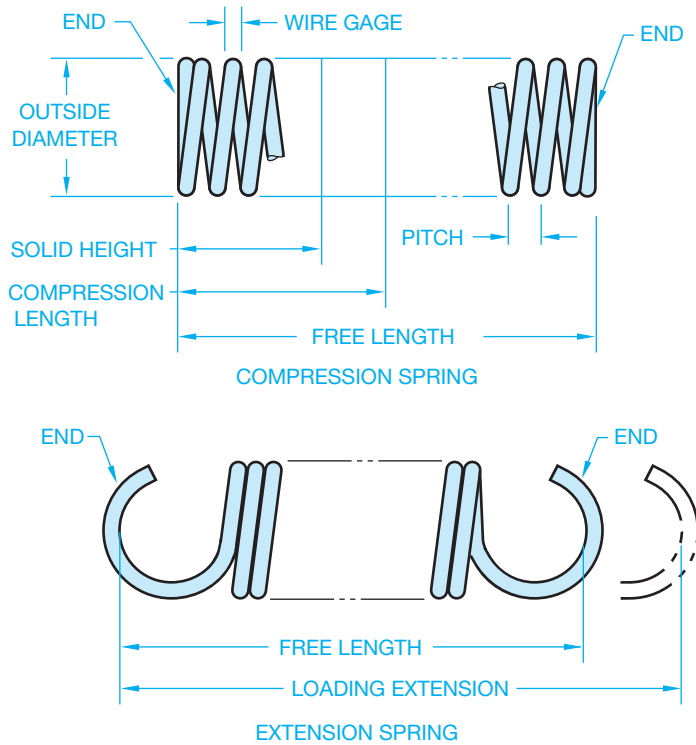


FIGURE 11.81 Spring characteristics. © Cengage Learning 2012

Compression springs are available with ground or unground ends. Unground, or rough, ends are less expensive than ground ends. If the spring is required to rest flat on its end, then ground ends should be used. Spring function depends on one of two basic factors: compression or extension. **Compression springs** release their energy and return to their normal form when compressed. **Extension springs** release their energy and return to the normal form when extended (see Figure 11.80).

### Spring Terminology

The springs given in Figure 11.81 show common characteristics that are identified throughout the following discussion.

#### Coils

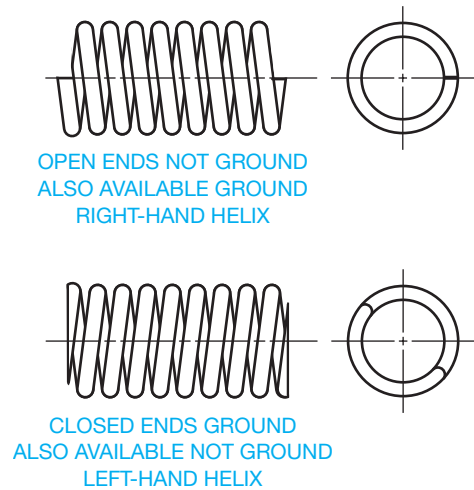
Helical springs are made in coils. A **coil** is one 360° revolution of the wire used to make the spring. **Active coils** are the total number of coils used to calculate the total deflection of a spring. **Total coils** are the number of active coils plus the coils used to form the spring ends for compression springs.

#### Deflection

**Deflection** is the movement from free length to the solid length in a compression spring. Deflection is the movement of a spring from free position to maximum open position in an extension spring.

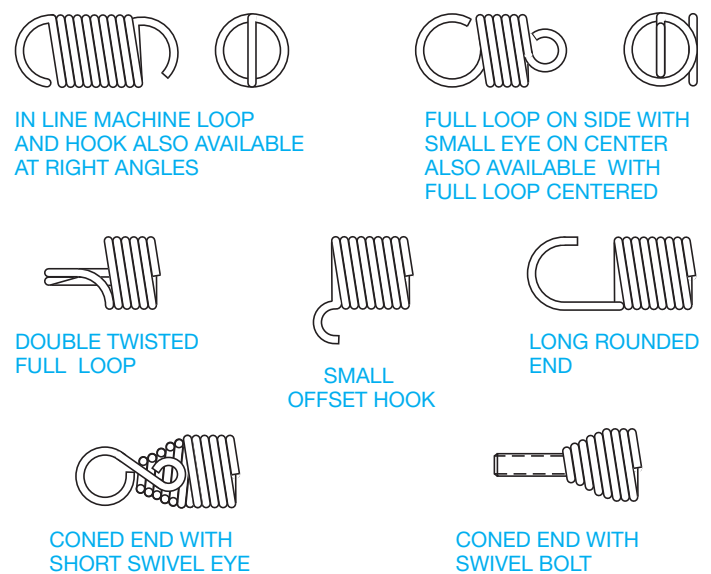
#### Spring Ends

Compression springs have four general types of ends: open or closed ground ends and open or closed unground ends, shown in Figure 11.82. Extension springs have a large variety of optional ends, a few of which are shown in Figure 11.83.



© Cengage Learning 2012

FIGURE 11.82 Helix direction and compression spring end types.



MANY OTHER COMBINATIONS ARE AVAILABLE

FIGURE 11.83 Extension spring end types. © Cengage Learning 2012

## Helix Direction

The **helix direction** can be specified as right-hand or left-hand. This is the direction of the twist used to create the spring (see Figure 11.82).

## Free Length

The length of the spring when there is no pressure or stress to affect compression or extension (see Figure 11.81).

## Compression Length

The **compression length**, also called the **solid length**, is the maximum recommended design length for the spring when compressed (see Figure 11.81).

## Solid Height

The **solid height** is the maximum compression possible. The design function of the spring should not allow the spring to reach solid height when in operation unless this factor is a function of the machinery (see Figure 11.81).

## Loading Extension

The **loading extension** extended distance to which an extension spring is designed to operate (see Figure 11.81).

## Pitch

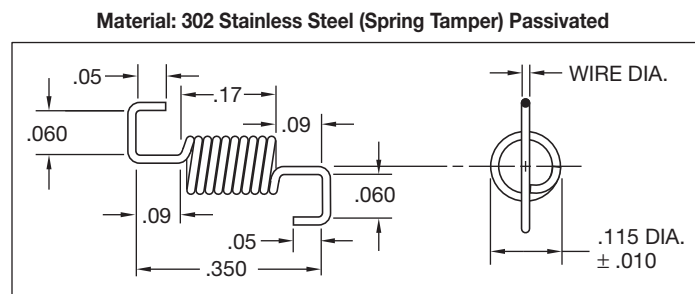
The **pitch** is one complete helical revolution, or the distance from a point on one coil to the same corresponding point on the next coil (see Figure 11.81).

## Torsion Springs

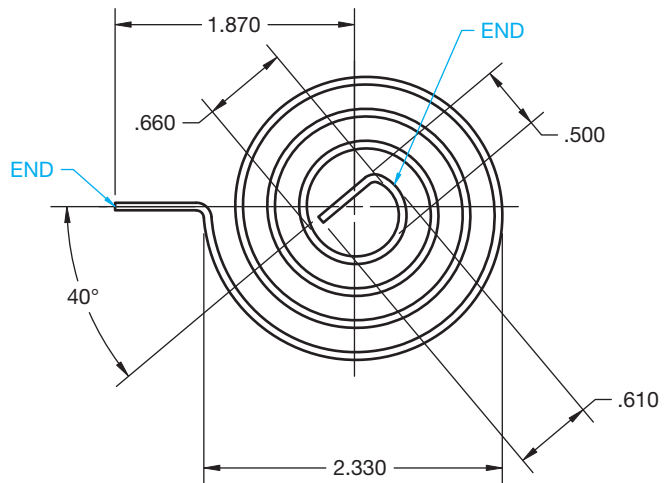
**Torsion springs** are designed to transmit energy by a turning or twisting action. **Torsion** is defined as a twisting action that tends to turn one part or end around a longitudinal axis while the other part or end remains fixed. Torsion springs are often designed as antibacklash devices or as self-closing or self-reversing units.

### Helical Torsion Spring

**Helical torsion springs** are designed to provide resistance or to exert a turning force in a plane at  $90^\circ$  to the axis of the coil. Helical torsion springs can be designed with a variety of ends for use in their applications (see Figure 11.84).



**FIGURE 11.84** Torsion spring, also called an *antibacklash spring*.  
Courtesy Nordex, Inc.



© Cengage Learning 2012

**FIGURE 11.85** The spiral torsion spring is designed to wind up and exert force in a rotating direction around the spring axis.

### Spiral Torsion Spring

A **spiral torsion spring** is made by winding flat spring material into a coil in the form of a spiral. The spiral torsion spring is designed to wind up and exert force in a rotating direction around the spring axis. The force can be delivered as **torque** or applied in a push and pull action (see Figure 11.85). Torque is a turning force around an axis.

### Torsion Bar Spring

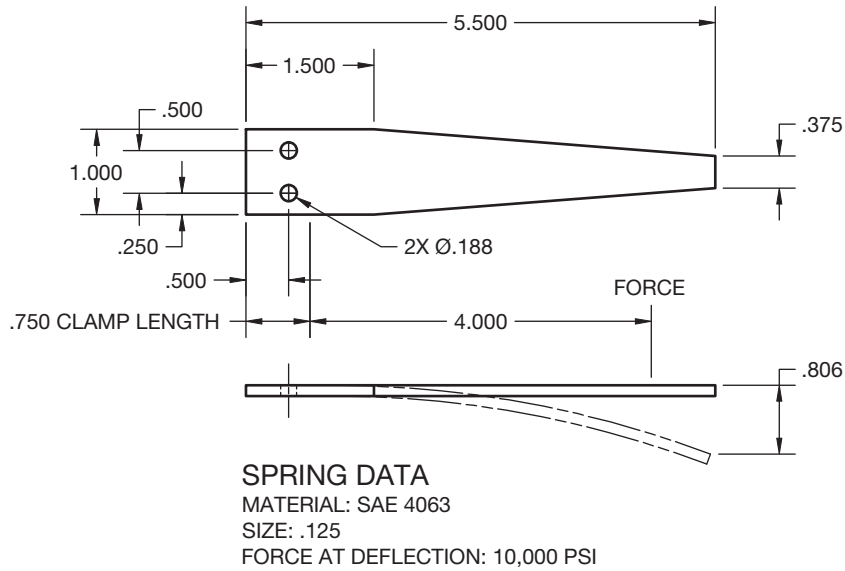
A **torsion bar spring** is a straight bar or rod used to provide resistance to a twisting movement around a longitudinal axis. The cross section can be round, square, rectangular, or hexagonal. The ends of the torsion bar spring are usually flattened to allow for fastening at the ends.

## Flat Springs

**Flat springs** are arched or bent flat-metal shapes designed so when placed in machinery they cause tension on adjacent parts. The tension can be used to level parts, provide a cushion, or position the relative movement of one part to another. One of the most common examples of flat springs are leaf springs on an automobile (see Figure 11.86).

## Wave Springs

**Wave springs** are also called **flat wire compression springs**. A wave spring occupies an extremely small area for the work it performs. Wave springs offer the advantage of space savings when used to replace coil springs in machine design. By reducing spring operating height, wave springs also produce a decrease in the spring cavity, which is the location where the spring is placed in the assembly. This feature can allow for a smaller assembly size and less material used in the manufacturing process. Wave springs can also operate as load-bearing



© Cengage Learning 2012

**FIGURE 11.86** Flat springs are arched or bent flat-metal shapes designed so when placed in machinery they cause tension on adjacent parts.

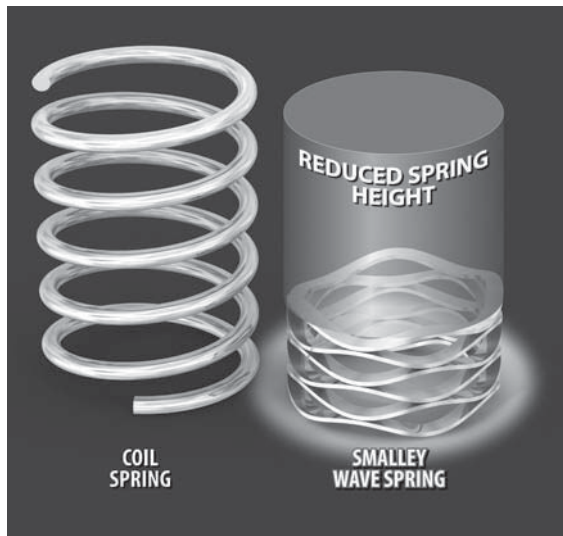
devices. They take up play and compensate for dimensional variations within assemblies. An unlimited range of forces can be produced whereby loads build either gradually or quickly to reach a predetermined working height. Wave springs can be used in **dynamic** and **static load** spring applications. A dynamic load is a type of load that changes in the direction or degree of force during operation. A static load is a type of load that maintains the same direction and degree of force during operation. Special performance characteristics are individually built into each spring to satisfy a variety of precise operating conditions. Figure 11.87 shows a comparison between a coil spring and a wave spring. Notice the spaces savings of the wave spring.

### Volute Spring

A **volute spring** is a conical shaped compression spring made of rectangular cross section material. The spring is manufactured in conical coils that are able to telescope into each other.

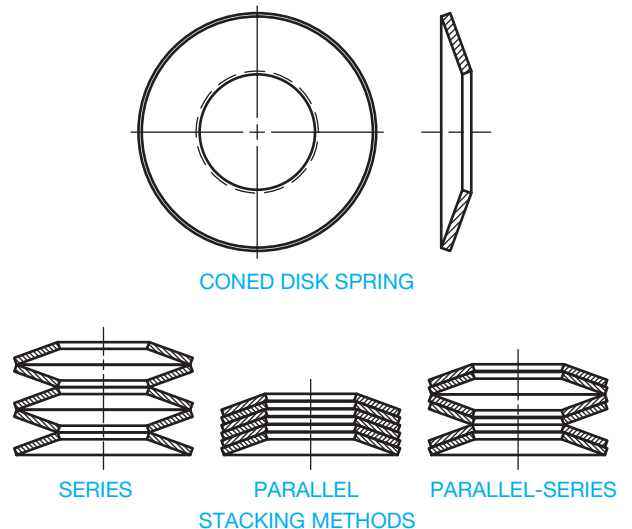
### Coned Disk Spring

The **coned disk spring**, also known as the Belleville spring, is a conically shaped spring washer for use as a compression spring (see Figure 11.88). Individual coned disk springs can be stacked in different arrangements for a variety of applications as shown in Figure 11.88.



Courtesy Smalley Steel Ring Company

**FIGURE 11.87** Wave springs are also called flat wire compression springs. A wave spring occupies a very small area for the work it performs.



© Cengage Learning 2012

**FIGURE 11.88** The coned disk spring is a conically shaped spring washer for use as a compression spring.



## Constant Force Spring

A **constant force spring** is made out of strip spring material similar to a spiral torsion spring. The inner end is normally not fastened so it is free to rotate. The coils do not expand. The outer end of the spring can be pulled, creating uniform force on the coil.

## Garter Spring

The **garter spring** is a long, close coil extension spring with hook or ring ends so the ends can be joined forming a large loop. Garter springs are used to hold round features together.

## SPRING REPRESENTATIONS AND SPECIFICATIONS

There are two types of spring representations: detailed and schematic as shown in Figure 11.89. The **detailed spring representation** is commonly used on most spring drawings and in situations that require a realistic representation, such as vendor's catalogs, assembly instructions, or detailed assemblies. The **schematic spring representations** is less commonly used on drawings. The single-line schematic symbols are easy to draw and clearly represent springs without taking the additional time required to draw a detailed spring, although the time element is normally not a factor with CADD applications. The use of either spring representation method must be accompanied by clearly written spring specifications.

### STANDARDS

#### ASME Standards Related to Springs

B18.8.100M, 2001: *Spring Pins: Coiled Type, Spring Pins: Slotted, Machine Dowel Pins: Hardened Ground, and Grooved Pins (Metric)*. This standard covers data for metric series coiled spring pins, slotted spring pins, hardened ground pins, and grooved pins.

B18.21.1, 2009: *Washers: Helical Spring-Lock, Tooth Lock, and Plain Washers (Inch Series)*. This standard covers the dimensional requirements, physical properties, and related test methods for helical spring-lock washers, tooth-lock washers, and plain washers.

B18.21.3, 2008: *Double Coil Helical Spring Lock Washers for Wood Structures*. This standard covers the dimensional and physical properties and methods of testing for double coil helical spring-lock washers for wood structures.



DETAILED



SCHEMATIC

© Cengage Learning 2012

FIGURE 11.89 Spring representations.

B18.8.2, 2000: *Taper Pins, Dowel Pins, Straight Pins, Grooved Pins, and Spring Pins (Inch Series)*. This standard covers data for taper, dowel, straight, grooved, and spring pins and information for the drilling of holes for taper pins and the testing of pins in double shear.

Y14.13M: *Mechanical Spring Representation*. This standard is no longer an American National Standard or an ASME-approved standard. It is available for historical reference only. This standard establishes uniform methods for specifying end product data on drawings for mechanical springs.

## Spring Specifications

No matter which spring representation method is used, several important specifications must accompany the spring drawing. This information is also referred to as **spring data**. Spring information is generally lettered in the form of a specific or general note or placed as dimensions on the spring drawing.

Spring specifications include:

- Outside or inside diameter.
- Wire gage.
- Material.
- Type of ends.
- Surface finish.
- Free and compressed length.
- Pitch.
- Number of coils.
- Helix direction.
- Force requirements.
- Types of ends.
- Torque.

When required, other information can include spring design criteria and heat-treatment specifications. The information is often provided on a drawing as shown in Figure 11.90. The material can also be duplicated in the title block or can be found only in the title block.

## Drawing a Detailed Coil Spring Representation

You need to use the spring data and dimensions when drawing a detailed coil spring representation. Determine the outside diameter, number of coils, wire diameter, and free length or compressed length.



SPRING DATA:

MATERIAL: 15 MOEN GAGE

NUMBER OF COILS: 12

TYPE OF ENDS: GROUND

HELIX DIRECTION: OPTIONAL

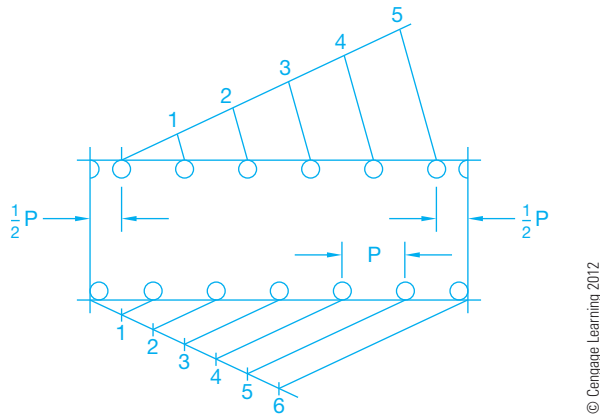
FIGURE 11.90 Detailed spring drawing with spring data chart.

© Cengage Learning 2012



© Cengage Learning 2012

FIGURE 11.91 Step 1: Preliminary spring layout.



© Cengage Learning 2012

FIGURE 11.92 Step 2: Spacing the coils.

The following steps show how to draw a detailed spring representation with the following specifications:

- Material: 2.5 mm diameter high-carbon spring steel
- Outside diameter: 16 mm
- Free length: 50 mm
- Number of coils: 6

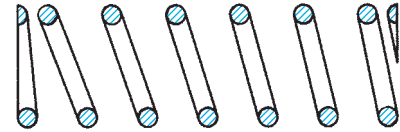
- STEP 1** Using construction lines, draw a rectangle equal to the outside diameter 16 mm wide with free length 50 mm long (see Figure 11.91).
- STEP 2** Along one inside edge of the length of the rectangle, draw seven equally spaced full circles, each with a 2.5 mm diameter. This is the wire size. The layout can be done by dividing the length into six equal spaces or by using a command such as ARRAY (see Figure 11.92). On the other inside edge, lay out a half circle at each end. Beginning at a distance of  $1/2 P$  away from one end, draw the first of six full 2.5 mm circles with equal spaces between them.
- STEP 3** Connect the circles drawn in Step 2 to make the coils. Draw lines from a point of tangency on one circle to a corresponding point on a circle on the other side. Draw the last element on each side down the edge of the rectangle for ground ends. To draw unground ends, make the last element terminate at the axis of the spring. Use a command such as TRIM to clean up unwanted line segments. Freeze or turn off the construction lines (see Figure 11.93).

For detailed coils in a longitudinal sectional view, leave the circles from Step 2 and draw that part of the spring that



© Cengage Learning 2012

FIGURE 11.93 Step 3: Connect the coils to complete the detailed spring representation.



© Cengage Learning 2012

FIGURE 11.94 Detailed spring representation in section.

appears as if the front half were removed as shown in Figure 11.94. Then fill in or section line the circles. Sectioning is described in detail in Chapter 12, *Sections, Revolutions, and Conventional Breaks*.

### Drawing a Detailed Coil Spring Representation Using Phantom Lines

Phantom lines can be used to simplify the drafting of repeated detail. This is an option, especially for a long spring where the detail is the same throughout the length. When using this practice, you draw a portion of each end of the spring as described in the previous steps and then draw phantom lines between the detailed ends as shown in Figure 11.95. This practice is not necessary with CADD applications, because of the ease and speed of drawing the entire spring, but it is an option when you want to simplify the drawing or reduce excess detail. Notice in Figure 11.95 that the FREE LENGTH is dimensioned on the spring and the LOADING EXTENSION is shown as an alternate position using phantom lines with a dimension provided.

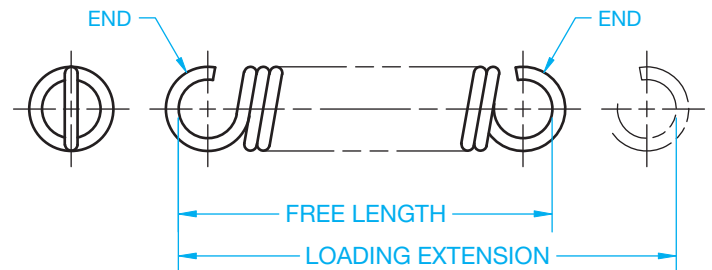


FIGURE 11.95 Phantom lines can be used to simplify the drafting of repeated detail. This is an option, especially for a long spring where the detail is the same throughout the length. © Cengage Learning 2012

## Drawing Schematic Spring Representations

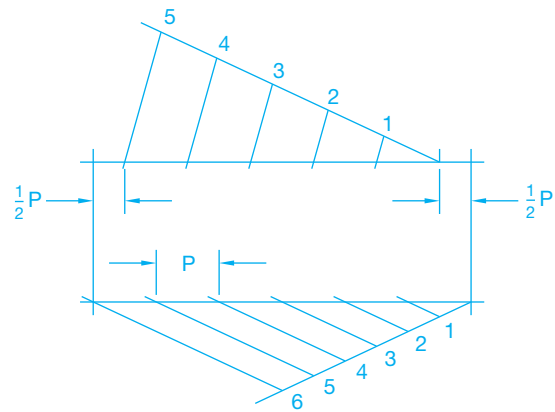
Schematic spring symbols are much easier to draw than detailed representations, and they clearly represent a spring. The schematic spring representation is an option, but it is not commonly used on drawings because of the ease of drawing detailed spring representations using CADD applications. The following steps show how to draw a schematic spring symbol for the same spring previously drawn:

- STEP 1** Use construction lines to draw a rectangle equal in size to the outside diameter by the free length as shown in Figure 11.91.
- STEP 2** Establish six equal spaces at  $P$  distance along one edge of the rectangle. Along the opposite edge begin and end with a space equal to  $1/2 P$ . Establish five equal spaces between the  $1/2 P$  ends (see Figure 11.96).
- STEP 3** Beginning on one side, draw the elements of each spring coil as shown in Figure 11.97.

### RECOMMENDED REVIEW

It is recommended that you review the following parts of Chapter 6, *Lines and Lettering*, before you begin working on fully dimensioned fastener and spring drawings. This will refresh your memory about how related lines are properly drawn.

- Object lines.
- Extension lines.
- Viewing planes.
- Hidden lines.



**FIGURE 11.96** Step 2: Spacing the coils.



**FIGURE 11.97** Step 3: Complete the schematic representation.

- Break lines.
- Phantom lines.
- Dimension lines.
- Leader lines.
- Centerlines.

In addition, review Chapters 8 and 9 covering multiview and auxiliary view drawings and Chapter 10, *Dimensioning and Tolerancing*, covering dimensioning practices.

### DRAWING SPRINGS

CADD offers a variety of commands and options that can assist you when creating a coil spring drawing. Common 2-D drafting commands for coil spring drawing include ARC, CIRCLE, LINE, COPY, MOVE, MIRROR, and TRIM. Drawing aids and layers also help to automate drawing springs. You can use the steps described in this chapter to draw the first coil spring and then copy the other coils as needed. In addition, springs, like fasteners, are

often standard parts that are used multiple times within a product or for several different projects. Reusing existing springs and using spring symbol libraries can save a significant amount of time by allowing designers and drafters to insert commonly used springs or to modify a basic spring to produce a unique drawing. Two-dimensional spring software is also available that automatically generates springs based according to the specifications and characteristics you input.

## CREATING SPRINGS

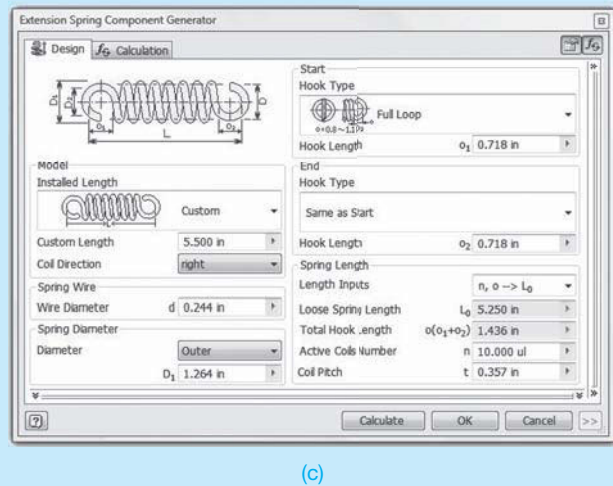
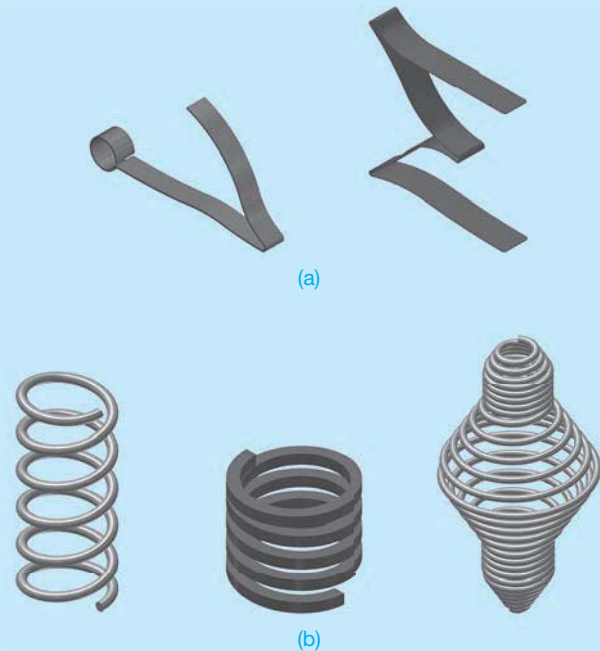
Three-dimensional CADD software allows you to model springs and prepare 2-D drawings from model content. Standard feature tools, such as EXTRUDE, or specialized sheet metal tools are common for some styles of springs, such as flat springs (see Figure 11.98a). Tools such as COIL, HELIX, and SWEEP are common for constructing solid model coil springs (see Figure 11.98b). The first step to developing a coil spring is to draw a profile or cross section of one of the coils. The profile is often of a circle that represents the wire diameter. You then draw or reference the axis of the coil spring in proper relationship to the coil cross section. Next, you specify a set of data that allows the software to build the 3-D coil spring model. Common input options include:

- Wire diameter.
- Number of coils.
- Coil direction.
- Outside diameter.
- Free length.
- Compressed length.
- End type.

Some CADD programs and specialized spring software systems make the process of adding springs to models very fast and easy. Instead of creating springs using feature tools, some CADD systems allow you to select spring variables and automatically generate a spring based on those specifications (see Figure 11.98c). CADD spring software allows you to select the following options, depending on the particular program:

- Outside diameter.
- Wire gage.
- Solid height.
- Compression length.
- Free length.
- Right or left-hand helix.
- Number of revolutions.
- Pitch.
- Extension or compression type.
- Open or closed ends.
- Ground or unground ends.
- Special ends.

After specifying the spring data, you typically choose a location to place the spring. Often you locate the spring in reference to associated components within the assembly. Then a model of the spring is automatically created using parametrics based on your specifications.



**FIGURE 11.98** (a) Examples of 3-D solid model flat springs. (b) Examples of 3-D solid model coil springs. (c) A specialized CADD tool for generating spring models.

Courtesy FLIR Systems, Inc.

## PROFESSIONAL PERSPECTIVE

Many CADD software programs are available that allow drawing of screw threads in simplified, schematic, or detailed representations. A complete variety of head types can be drawn easily. This type of CADD software makes an otherwise complex task very simple and saves drafting time. Regardless of the thread symbol used, the thread note tells the reader the exact thread specifications. This is why threads are shown on a drawing as a representation rather than as duplications of the real thing. The

simplified representation is the most commonly used technique, because it is easy to draw and accepted as a common standard.

Your goal as a professional drafter is to make the drawing communicate so that there is no question about what is intended. In simple terms, make the drawing clear and accurate using the easiest method, and make sure the thread note and specifications are complete and correct as shown in the real world example found in Figure 11.99.

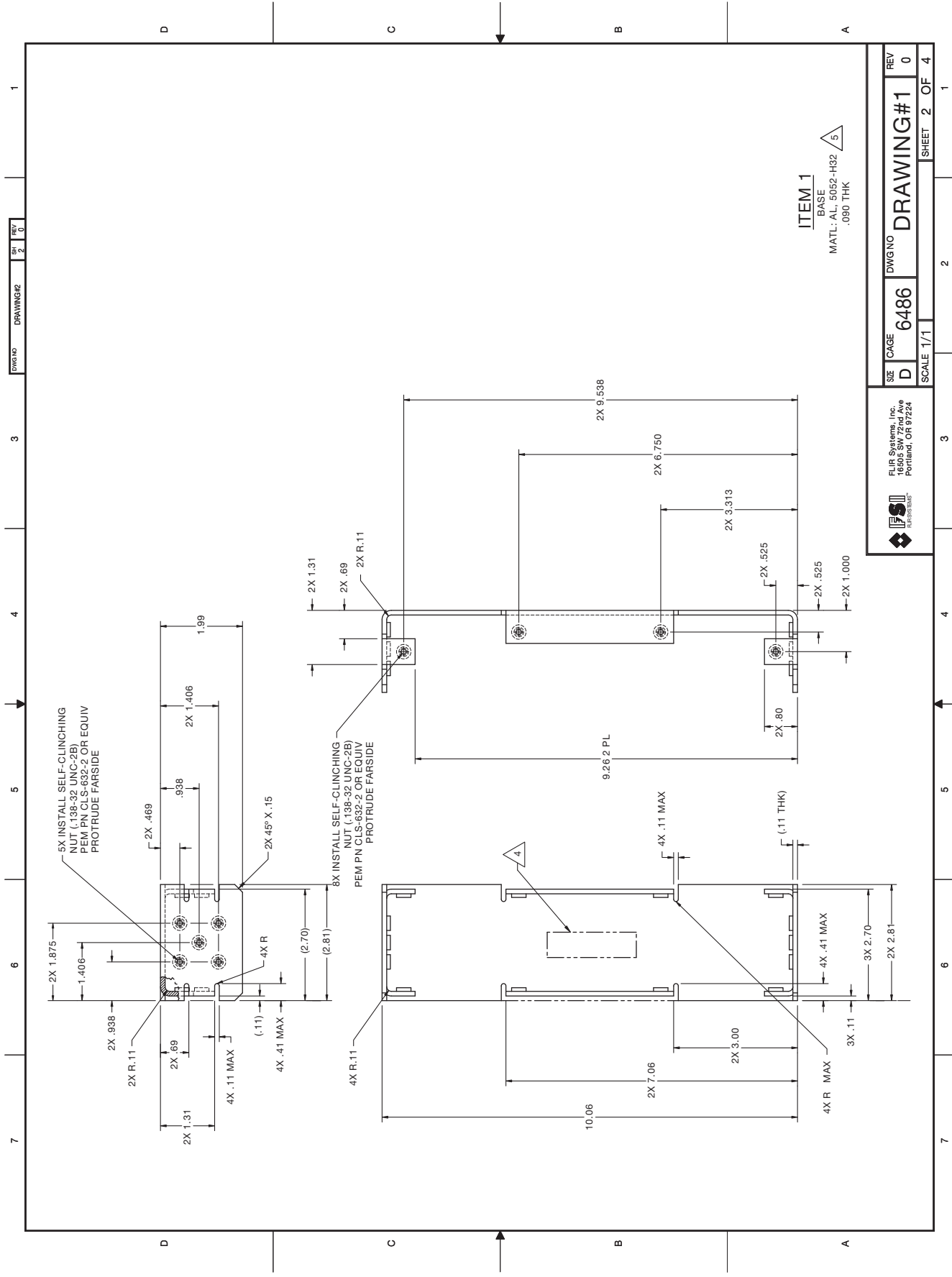


FIGURE 11.99 An actual industry drawing with fasteners displayed and specified.

## RATIO AND PROPORTION OF A TAPER PIN

**PROBLEM:** The taper of a pin is .25:12. What is the taper for the 3-in. long pin shown in Figure 11.100?

**SOLUTION:**

$$\frac{.25}{12} = \frac{x \text{ taper}}{3 \text{ length}}$$

$$(12)(x) = (.25)(3)$$

$$12x = .75$$

$$x = .75 \div 12$$

$$x = .0625 \text{ in.}$$

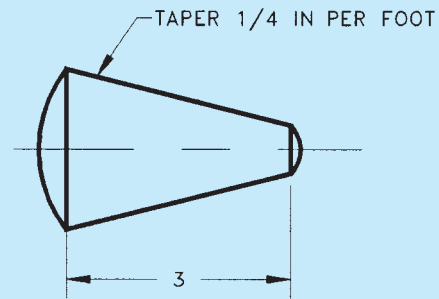


FIGURE 11.100 Taper pin.

© Cengage Learning 2012

## WEB SITE RESEARCH

Use the following Web sites as a resource to help find more information related to engineering drawing and design and the content of this chapter.

Address	Company, Product, or Service
<a href="http://www.adda.org">www.adda.org</a>	American Design Drafting Association and American Digital Design Association (ADDA International)
<a href="http://www.ansi.org">www.ansi.org</a>	American National Standards Institute (ANSI)
<a href="http://www.asme.org">www.asme.org</a>	American Society of Mechanical Engineers (ASME)
<a href="http://www.avdel.textron.com">www.avdel.textron.com</a>	Technical information on fasteners
<a href="http://www.cadtechcorp.com">www.cadtechcorp.com</a>	CADD fasteners software applications
<a href="http://www.globalspec.com">www.globalspec.com</a>	The Engineering Web makes it faster and easier for you to research topics, products, and services by limiting your search to technical and engineering-related Web sites
<a href="http://www.industrialpress.com">www.industrialpress.com</a>	Information about the <i>Machinery's Handbook</i> . This is a valuable resource for all types of fasteners and fastener specifications
<a href="http://www.iso.org">www.iso.org</a>	International Organization for Standardization
<a href="http://www.sae.org">www.sae.org</a>	Find information and publications related to the Society of Automotive Engineers
<a href="http://www.thomasnet.com">www.thomasnet.com</a>	CAD symbols

## Chapter 11 Fasteners and Springs Test



To access the Chapter 11 test, go to the Student CD, select **Chapter Tests and Problems**, and then **Chapter 11**. Answer the questions

with short, complete statements, sketches, or drawings as needed. Confirm the preferred submittal process with your instructor.

## Chapter 11 Fasteners and Springs Problems

### INSTRUCTIONS

- From the selected problems, determine which views and dimensions should be used to completely detail the part. Use simplified representation for thread representations unless otherwise specified in the instructions or by your instructor. Use detailed representation for spring representations unless otherwise specified in the instructions or by your instructor.
- Make a multiview sketch to proper proportions, including dimensions and notes.
- Using the sketch as a guide, draw an original multiview drawing on an adequately sized ASME drawing sheet with border and sheet blocks. Add all necessary dimensions and notes using unidirectional dimensioning.
- Include the following general notes at the lower left corner of the sheet .5 in. each way from the corner border lines:

#### NOTES:

- DIMENSIONING AND TOLERANCING PER ASME Y14.5-2009.
- REMOVE ALL BURRS AND SHARP EDGES.

Additional general notes may be required, depending on the specifications of each individual assignment. Use the following for tolerances for unspecified inch values. A tolerance block is recommended as described in Chapter 2, *Drafting Equipment, Media, and Reproduction Methods*, and as shown in problems for Chapter 10, *Dimensioning and Tolerancing*, unless otherwise specified.

UNSPECIFIED TOLERANCES		
DECIMALS	mm	IN
X		±.1
XX		±.01
XXX		±.005
ANGULAR		±30'
FINISH	3.2 μm	125 μin.

For metric drawings, provide a general note that states TOLERANCES FOR UNSPECIFIED DIMENSIONS COMPLY WITH ISO 2768-m. Provide a general note that states SURFACE FINISH 3.2 μm UNLESS OTHERWISE SPECIFIED.



### Drafting Templates

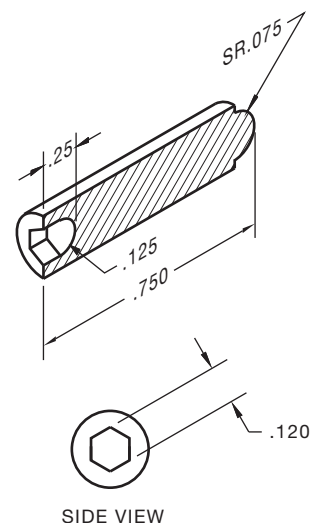
To access CADD template files with predefined drafting settings, go to the Student CD, select **Drafting Templates**, and then select the appropriate template file. Use the templates to create new designs, as a resource for drawing and model content, or for inspiration when developing your own templates. The ASME-Inch and ASME-Metric drafting templates follow ASME, ISO, and related mechanical drafting standards. Drawing templates include standard sheet sizes and formats, and a variety of appropriate drawing settings and content. You can also use a utility such as the AutoCAD DesignCenter to add content from the drawing templates to your own drawings and templates. Consult with your instructor to determine which template drawing and drawing content to use.

#### Part 1: Problems 11.1 Through 11.24

##### PROBLEM 11.1 (in.)

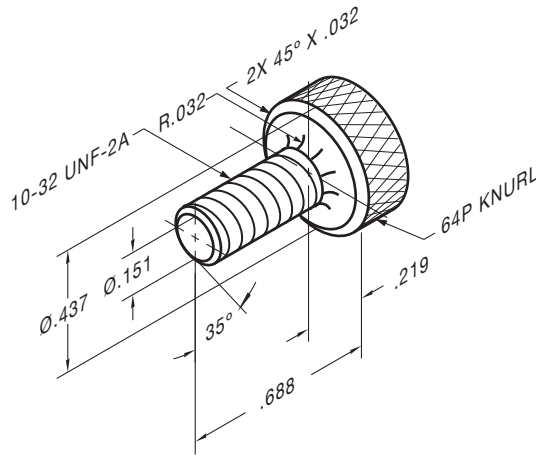
Part Name: Full Dog Point Gib Screw

Material: 10-32 UNF-2A .75 long



**PROBLEM 11.2 (in.)**

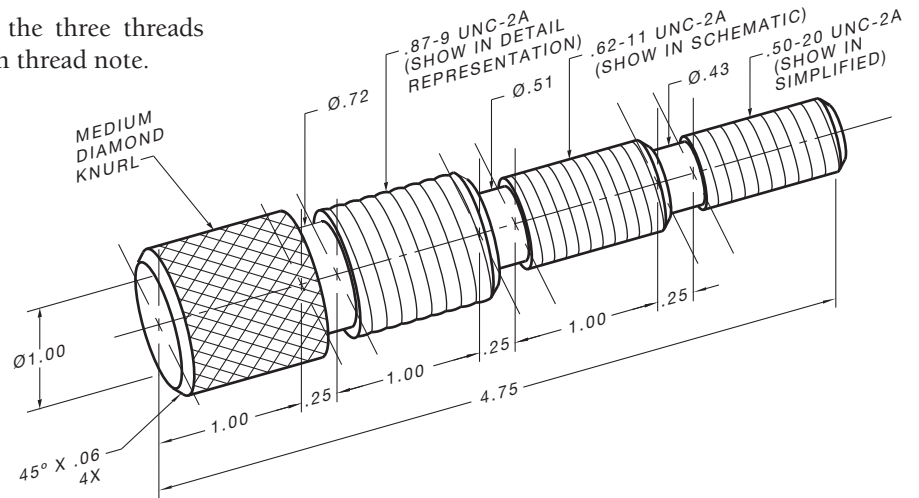
Part Name: Thumb Screw  
 Material: SAE 1315 steel



© Cengage Learning 2012

**PROBLEM 11.3 (in.)**

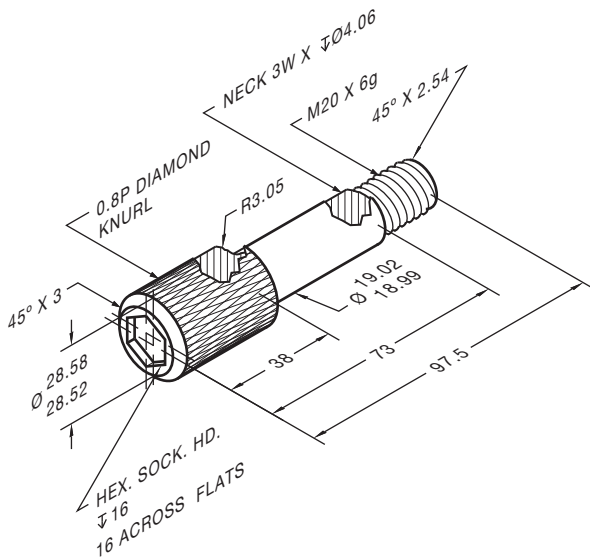
Part Name: H-Step Threading Screw  
 Material: SAE 3130  
 SPECIFIC INSTRUCTIONS: Draw each of the three threads using the representation specified below each thread note.



© Cengage Learning 2012

**PROBLEM 11.4 (metric)**

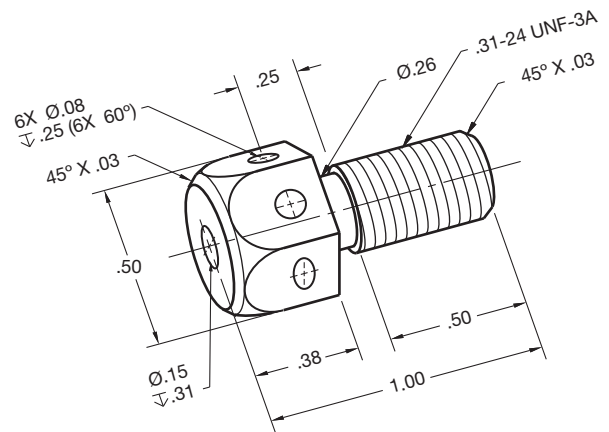
Part Name: Knurled Hex Soc Head Step Screw  
 Material: SAE 1040  
 Case Harden: 1.6 mm deep per Rockwell C Scale  
 Finish: 2 µm; black oxide



© Cengage Learning 2012

**PROBLEM 11.5 (in.)**

Part Name: Machine Screw  
 Material: Stainless steel  
 Finish All Over: 2 µm

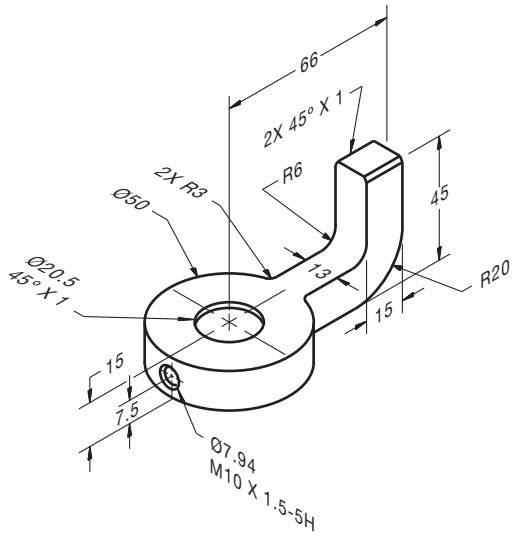


© Cengage Learning 2012



**PROBLEM 11.6 (metric)**

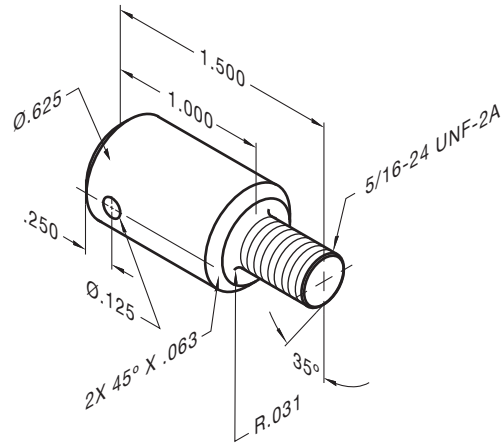
Part Name: Lathe Dog  
Material: Cast iron



© Cengage Learning 2012

**PROBLEM 11.9 (in.)**

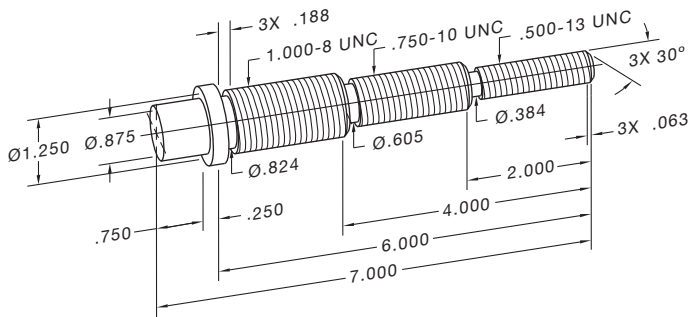
Part Name: Shoulder Screw  
Material: SAE 4320 steel



© Cengage Learning 2012

**PROBLEM 11.7 (in.)**

Part Name: Threaded Step Shaft  
Material: SAE 1030



© Cengage Learning 2012

**PROBLEM 11.10 (in.)**

Part Name: Stop Screw  
Material: SAE 4320  
Hex Depth: .175  
Note: Medium diamond knurl at head

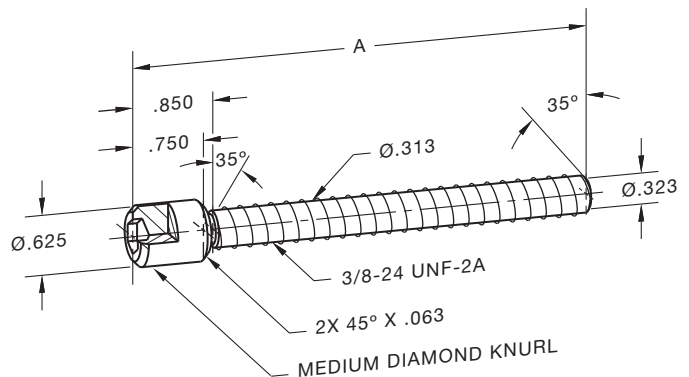
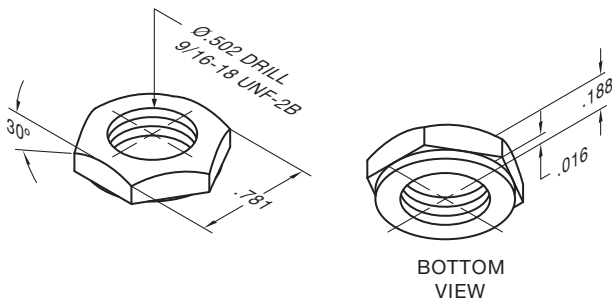


CHART A	
PART #	LENGTH
1DT-1011	4.438
1DT-1012	3.688

© Cengage Learning 2012

**PROBLEM 11.8 (in.)**

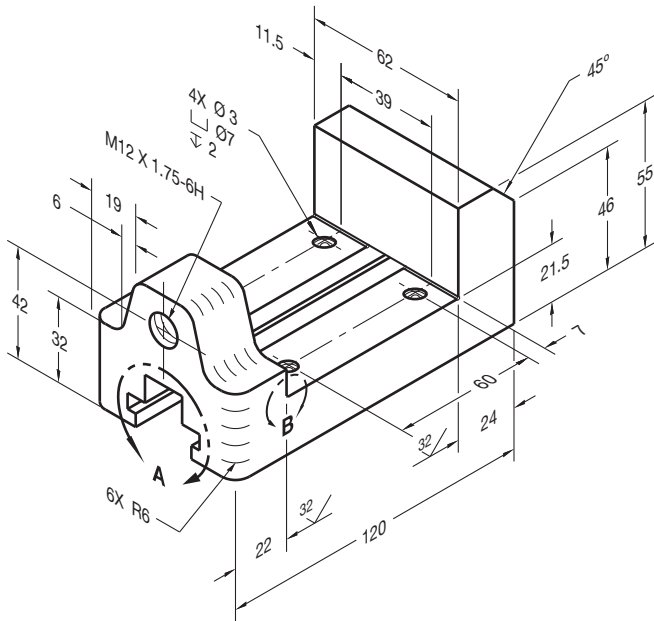
Part Name: Washer Face Nut  
Material: SAE 1330 steel



© Cengage Learning 2012

**PROBLEM 11.11 (metric)**

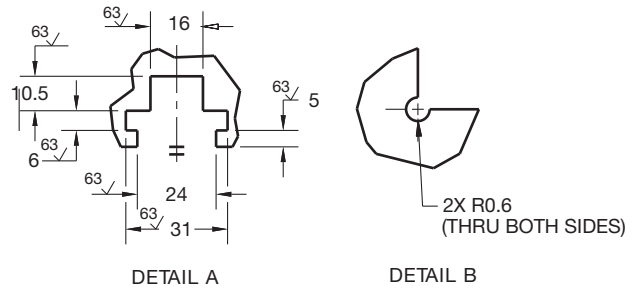
Part Name: Vise base  
 Material: Cast iron



**PROBLEM 11.12 (metric)**

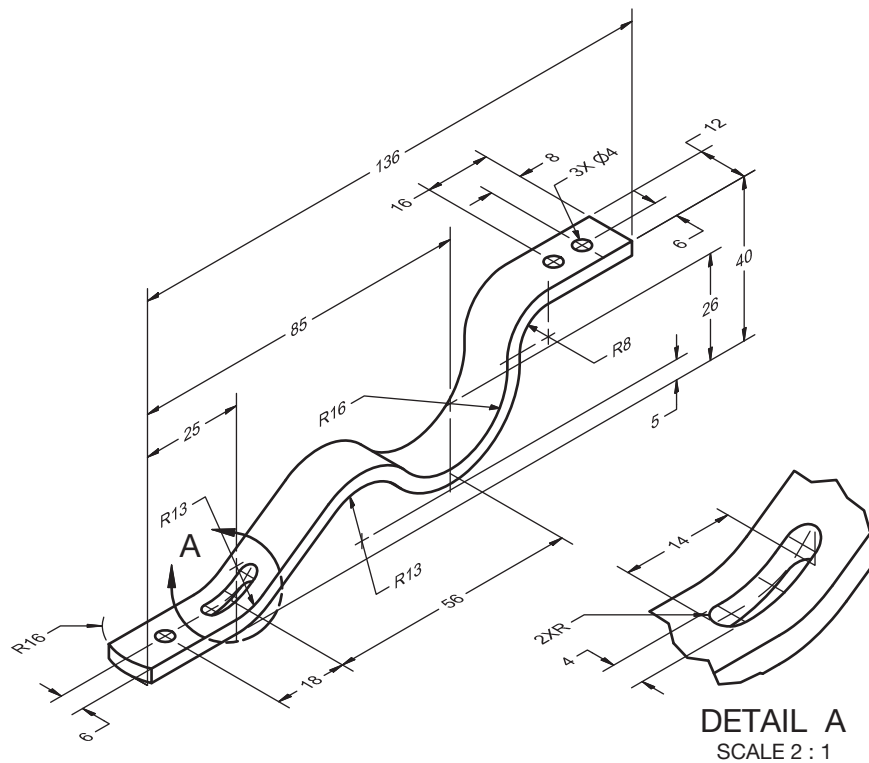
SPECIFIC INSTRUCTIONS: Create spring drawing based on the following specifications:

Part Name: Compression Spring  
 Material: 2.5 mm steel spring wire  
 Ends: Plain Ground  
 Outside Diameter: 25  
 Free Length: 75  
 Number of Coils: 16  
 Finish: Chrome plate



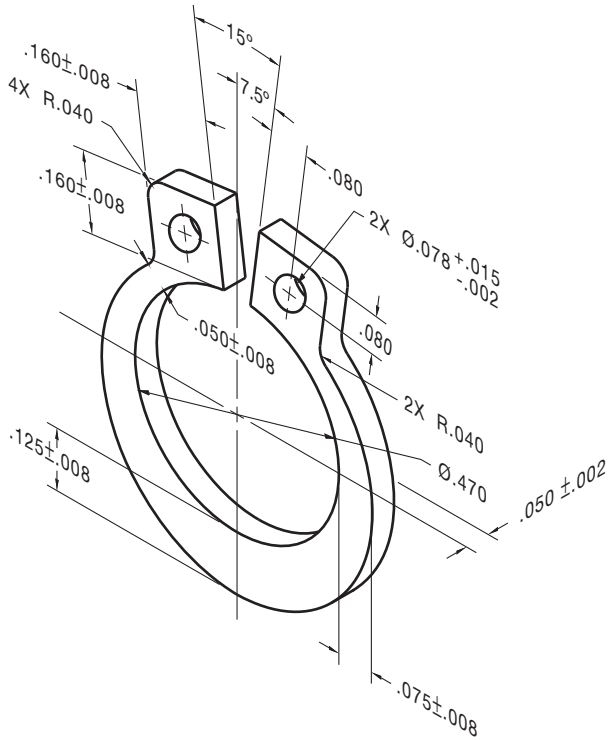
**PROBLEM 11.13 (metric)**

Part Name: Flat Spring  
 Material: 3.5 mm spring steel  
 Finish: Black oxide  
 Heat Treat: 1 mm deep Rockwell C scale



**PROBLEM 11.14 (in.)**

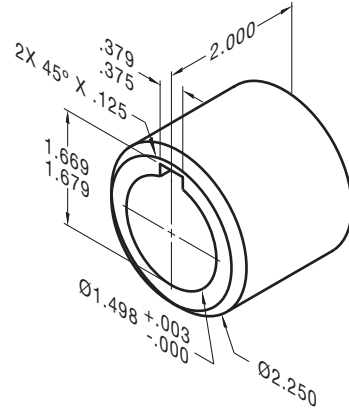
Part Name: Retaining Ring  
Material: Stainless steel



© Cengage Learning 2012

**PROBLEM 11.16 (in.)**

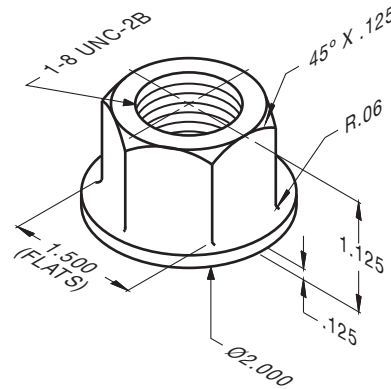
Part Name: Collar  
Material: SAE 1020



© Cengage Learning 2012

**PROBLEM 11.17 (in.)**

Part Name: Bearing Nut  
Material: SAE 1040

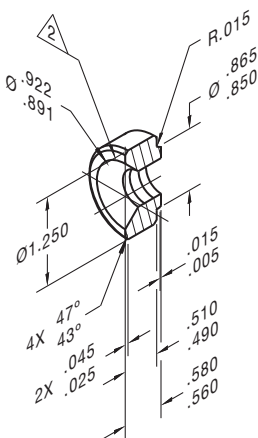


© Cengage Learning 2012

**PROBLEM 11.15 (in.)**

Part Name: Half Coupling  
Material: Ø1.250 C1215 steel

Problem based on original art courtesy TEMCO.



HALF OF PART SHOWN FOR CLARITY.

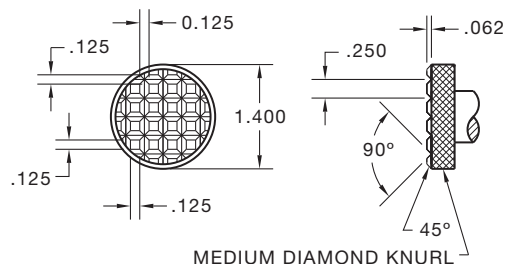
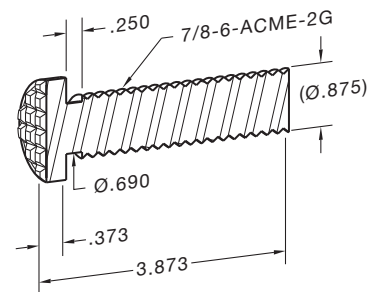
OUTSIDE SURFACE OF COUPLING MUST BE FREE OF OXIDIZATION AND INK.



.500-14 NPTF: L-1 GAGE, PLUS 1/MINUS 1 TURNS FROM NOMINAL. TAP FROM THIS END.

**PROBLEM 11.18 (in.)**

Part Name: Adjustment Screw  
Material: SAE 2010 steel

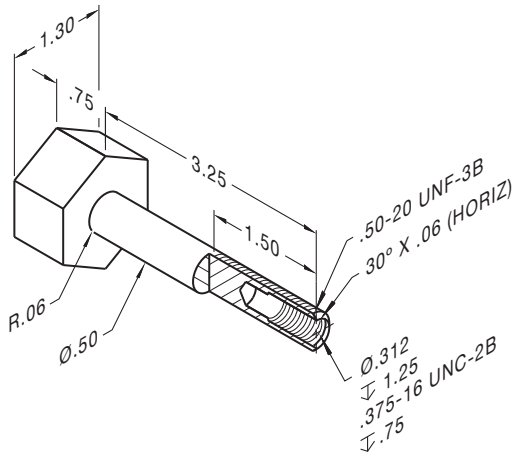


© Cengage Learning 2012

**PROBLEM 11.19 (in.)**

Part Name: Screw Shaft

Material: 3/4 hex X 4 1/8 stock mild steel

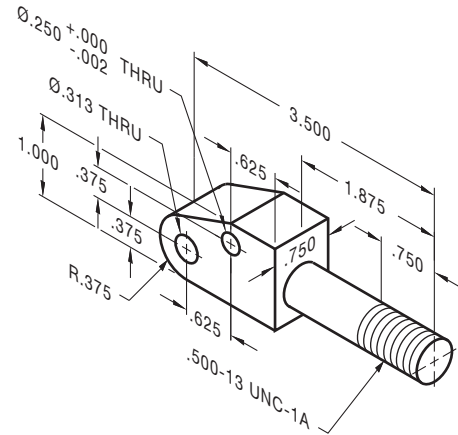


© Cengage Learning 2012

**PROBLEM 11.21 (in.)**

Part Name: Pump Pivot Support

Material: Cold-rolled mild steel



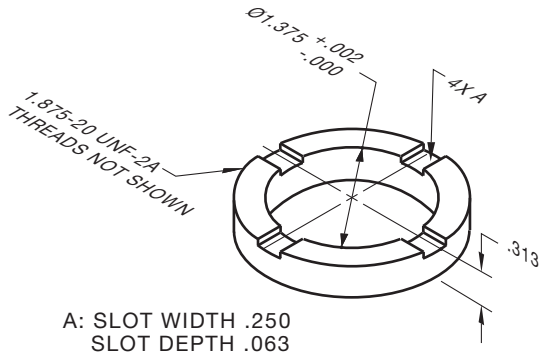
© Cengage Learning 2012

**PROBLEM 11.20 (in.)**

Part Name: Packing Nut

Material: Bronze

A: Spanner slots .250 wide X .063 deep.



© Cengage Learning 2012

**PROBLEM 11.22 (in.)**

Part Name: Set Screw

Material: Steel

SPECIFIC INSTRUCTIONS: Prepare a detailed drawing from the written instructions below.

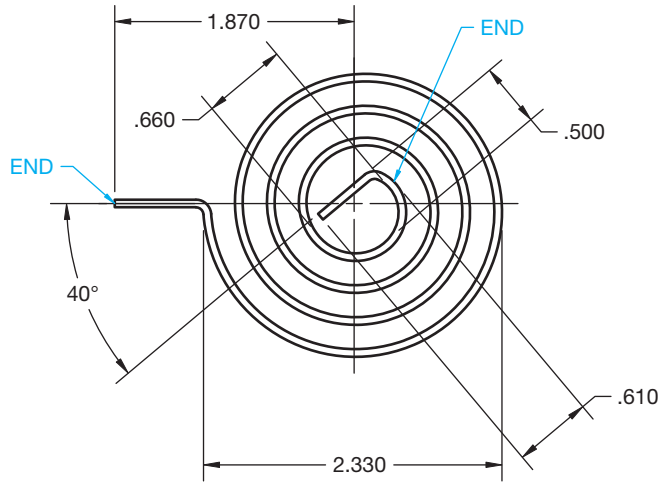
10-32 UNF-2A THREADED  
MATERIAL .375 LG.  
W/ .015 LATERAL X 35°  
CHAMFERS ON BOTH ENDS  
PROVIDE A .030 WIDE X  
.047 DEEP SLOT ON  
ONE END.

© Cengage Learning 2012

PROBLEM 11.23 (in.)

Part Name: Spiral Torsion Spring

Material: SAE 1060

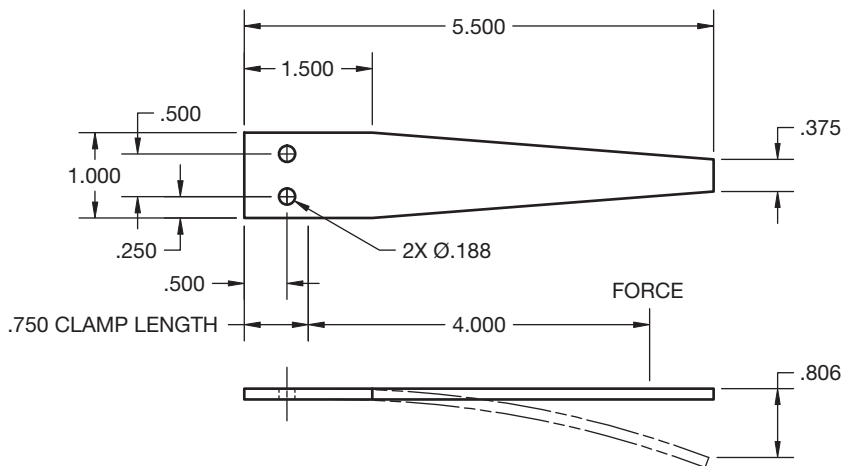


© Cengage Learning 2012

PROBLEM 11.24 (in.)

Part Name: Flat Spring

Material: SAE 4063



**SPRING DATA**  
 MATERIAL: SAE 4063  
 SIZE: .125  
 FORCE AT DEFLECTION: 10,000 PSI

© Cengage Learning 2012

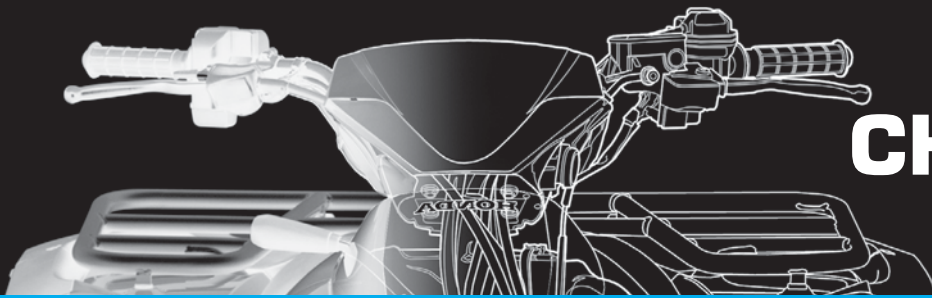
Math Problems

Part 2: Problems 11.25 Through 11.31



To access the Chapter 11 problems, go to the Student CD, select **Chapter Tests and Problems** and **Chapter 11**, and then open the

math problem of your choice or as assigned by your instructor. Solve the problems using the instructions provided on the CD, unless otherwise specified by your instructor.



# CHAPTER 12

## Sections, Revolutions, and Conventional Breaks

### LEARNING OBJECTIVES

After completing this chapter, you will:

- Draw proper cutting-plane line representations.
- Draw sectional views, including full, half, aligned, broken-out, auxiliary, revolved, and removed sections.
- Identify features that should remain unsectioned in a sectional view.
- Prepare drawings with conventional revolutions and conventional breaks.
- Modify the standard sectioning techniques as applied to specific situations.
- Make sectional drawings from given engineers' sketches and actual industrial layouts.

### THE ENGINEERING DESIGN APPLICATION

You are working with an engineer on a special project, and she gives you a rough sketch of a part from which you are to make a formal drawing. At first glance, you think it is an easy part to draw, but with further study you realize that it is more difficult than it looks. The rough sketch, shown in Figure 12.1, has many hidden features. Therefore, your first thought is that a front

exterior view would show only the diameter and length. So instead of drawing an outside view, you decide to use a full section to expose all of the interior features and give the overall length and diameter at the same time. Next, you realize there are six holes spaced  $60^\circ$  apart that remain as hidden features in the left-side view. This is undesirable because you do not want to section all

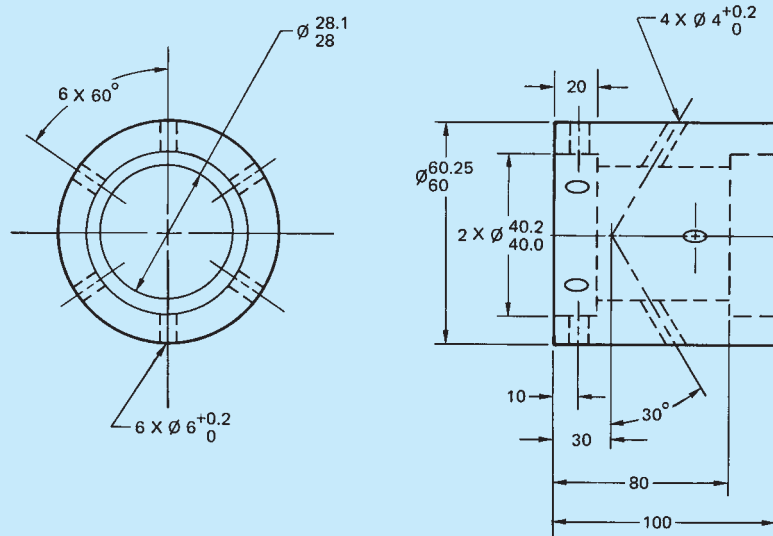


FIGURE 12.1 Engineer's layout drawing.

© Cengage Learning 2012

of the holes. Therefore, you decide to use a broken-out section to expose only two holes. This allows you to dimension the  $6 \times 60^\circ$  and the  $6 \times \varnothing 6^{+0.2}_0$  holes all at the same time. Now with all this thinking and planning

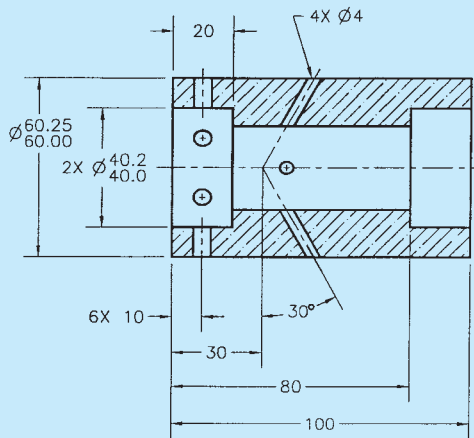
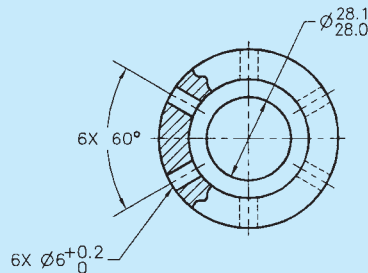


FIGURE 12.2 CADD solution to engineering problem.

## STANDARDS

**ASME** The American Society of Mechanical Engineers document that governs sectioning techniques is ASME Y14.3 titled *Multi and Sectional View Drawings*. The engineering standard *Line Conventions and Lettering*, ASME Y14.2, covers the principles of drawing-recommended cutting-plane and section lines. The content of this chapter is based on the ASME standard and provides an in-depth analysis of the techniques and methods of sectional view presentation.

## INTRODUCTION TO SECTIONAL VIEWS

**Sectional views** are also called **sections**, and the process of creating sections is referred to as **sectioning**. Sections are used to describe the interior portions of an object that are otherwise difficult to visualize. Interior features that are described using hidden lines are not as clear as if they are exposed for viewing as visible features. It is also a poor practice to dimension to hidden features. The sectional view allows you to expose the hidden features for dimensioning. Figure 12.3 shows an object in conventional multiview representation and using a sectional view. Notice how the hidden features are clarified in the sectional view. There are a variety of sectioning methods for different applications discussed throughout this chapter.

## CUTTING-PLANE LINES AND SECTIONAL VIEW IDENTIFICATION

The sectional view is created by placing an imaginary cutting plane through the object that cuts away the area to be exposed. The adjacent view becomes the sectional view by removing the

out of the way, it only takes you three hours to completely draw and dimension the part, and you are ready to give the formal drawing, shown in Figure 12.2, to the checker.

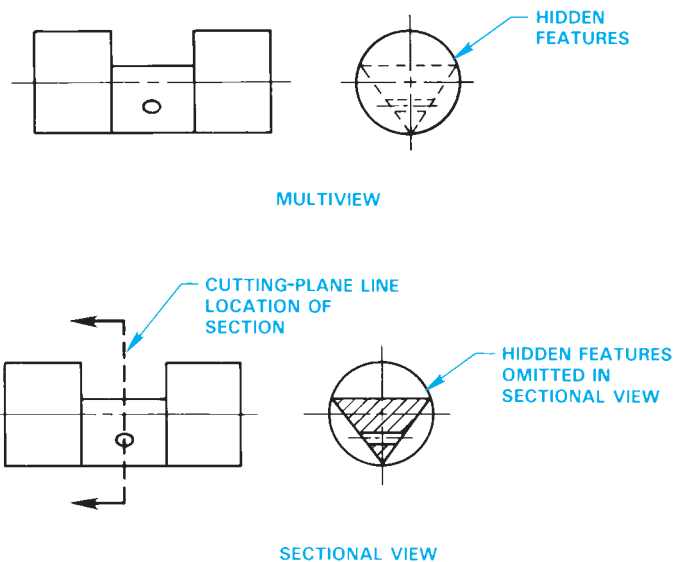


FIGURE 12.3 Convention multiview compared to a sectional view.

© Cengage Learning 2012

portion of the object between the viewer and the cutting plane (see Figure 12.4).

The sectional view should project from the view that has the cutting plane as you normally project a view in multiview. The **cutting-plane line** is a thick line representing the cutting plane as shown in Figure 12.4. The cutting-plane line can be drawn using alternating long and two short dashes, or evenly spaced dashes. The long dashes can vary in length depending on the size of the drawing, but the short dashes are generally .25 in. (6 mm) in length. Figure 12.4 shows an example of the cutting-plane line styles. The cutting-plane line is capped on the ends, with arrowheads showing the direction of sight of the sectional

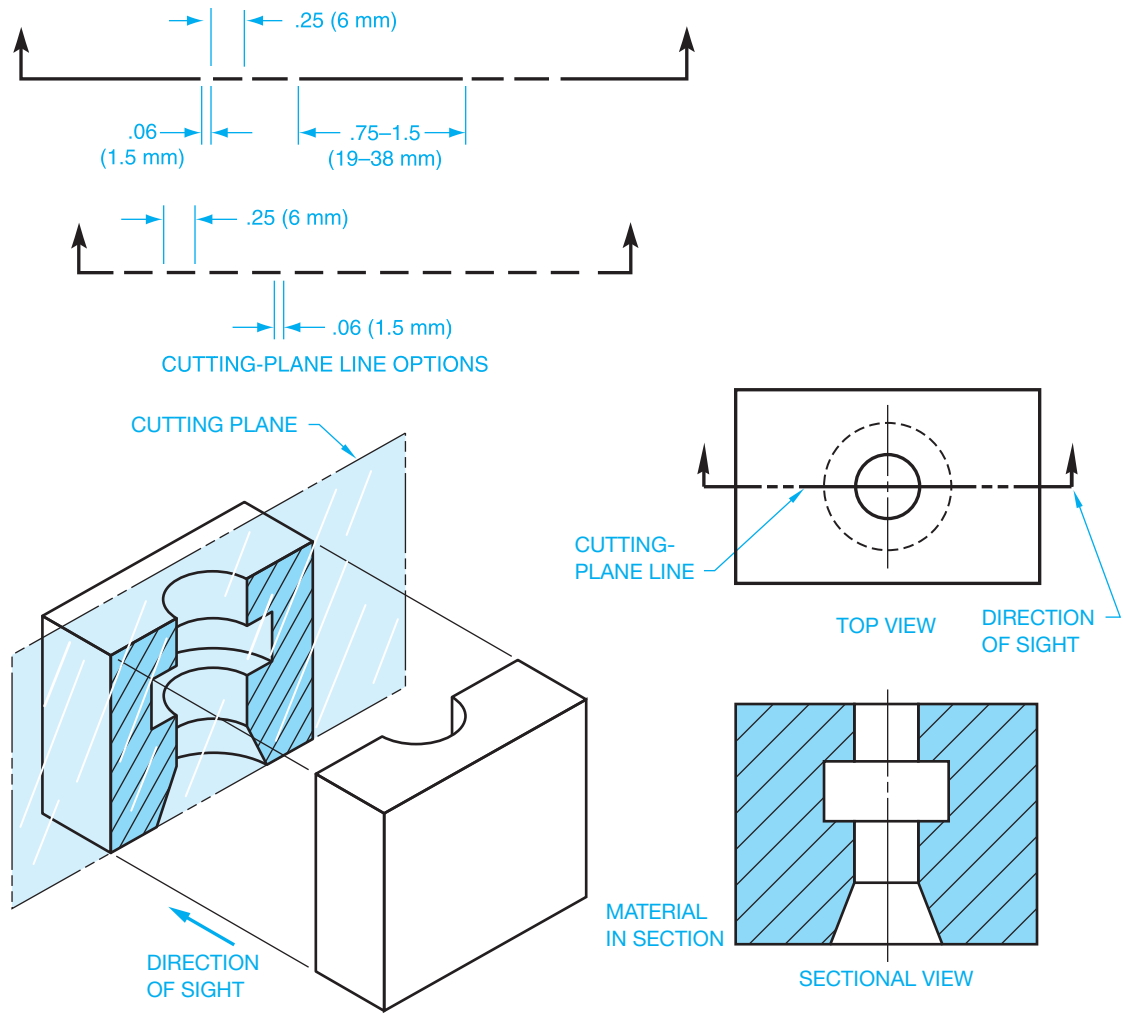


FIGURE 12.4 Cutting-plane line and sectional view visualization.

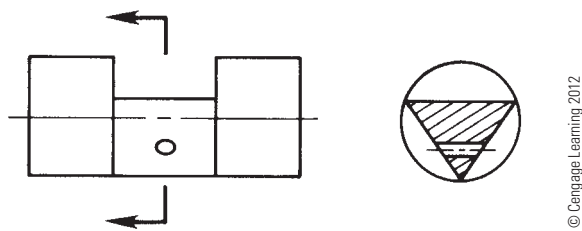


FIGURE 12.5 Simplified cutting-plane line showing only the ends of the cutting-plane line.

view. The cutting-plane line arrowheads maintain the same 3:1 length-to-width ratio as dimension line arrowheads. Cutting-plane line arrowheads are generally twice the size of dimension line arrowheads, so they show up better on the drawing. If the dimension line arrowheads are .125 (3 mm) long on your drawing, then make the cutting-plane line arrowheads .25 in. (6 mm) long. This depends on the size of the drawing and your school or company standards. When the extent of the cutting plane is obvious, only the ends of the cutting-plane line can be used as shown in Figure 12.5. Such treatment of the cutting plane also helps keep the view clear of excess lines.

The sectional view should be projected from and perpendicular to the cutting-plane line and placed as one of the standard principal multiviews. If lack of space restricts the normal placement of a sectional view, the view can be placed in an alternate location. When this is done, the sectional view should not be rotated but should remain in the same orientation as if it is a direct projection from the cutting plane. The cutting planes and related sectional views should be labeled with letters beginning with AA as shown in Figure 12.6. The cutting-plane line labels should be placed near the arrowheads. An option is to place only one identification letter at one arrowhead when a continuous cutting-plane line is used and the application is clear. The text height for cutting-plane line labels and the correlated view identification is generally the same text height used for drawing titles, which is typically .24 in. (6 mm). When the cutting-plane line has labels A on each end, then the sectional view has the related title SECTION A-A placed below the sectional view. When there is more than one sectional view on a drawing, the additional cutting-plane lines and views are labeled BB, CC, and so on. The letters I, O, Q, S, X, and Z are not used for sectional view identification. If there are enough sectional



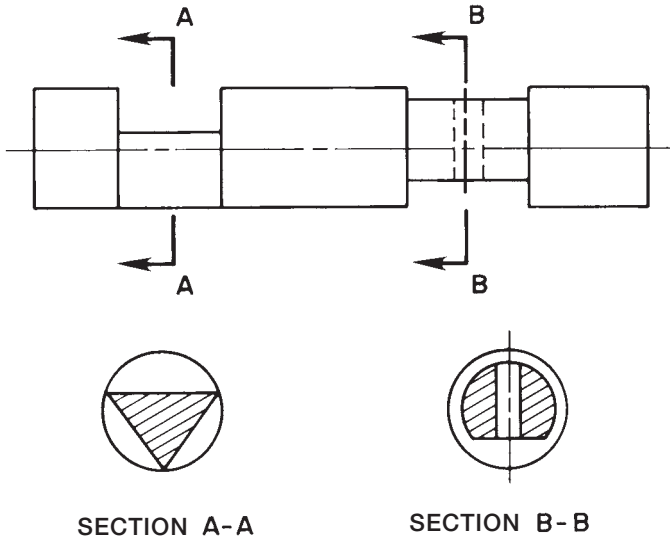


FIGURE 12.6 Labeled cutting-plane lines and related sectional view.

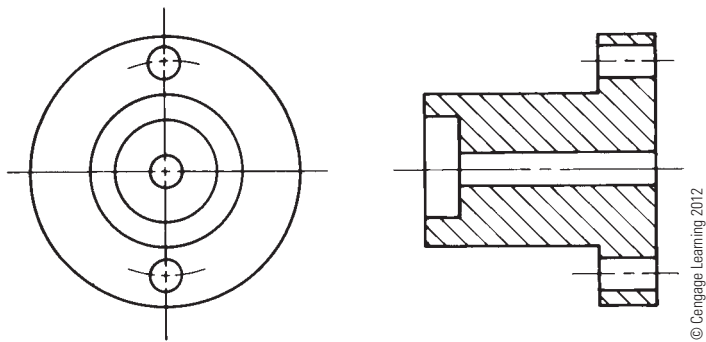


FIGURE 12.7 An obvious cutting-plane line can be omitted.

views on a drawing to use up all of the letters of the alphabet, then double letters are used to label the cutting-plane lines and related views, such as AA-AA, AB-AB, and AC-AC.

The cutting-plane line can be omitted when the location of the cutting plane is obvious as shown in Figure 12.2 and Figure 12.7. When in doubt, use the cutting-plane line.

The order of precedence of lines on a drawing was introduced in Chapter 8, *Multiviews*. Refer to Figure 8.57. Cutting-plane lines take precedence over centerlines.

**NOTE:** The following are poor sectioning practices that should not be used:

- Never take a section from a section. In other words, do not put a cutting-plane line in a section view in order to establish another section view.
- Never projected a standard multiview from a section view.

## SECTION LINES

**Section lines** are thin lines used in the view of the section to show where the cutting-plane line has cut through material (see Figure 12.8). Section lines are usually drawn equally spaced at

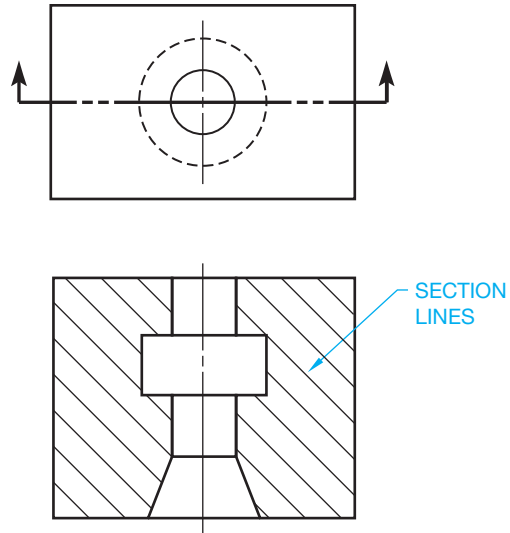


FIGURE 12.8 Section lines represent the material being cut by the cutting plane.

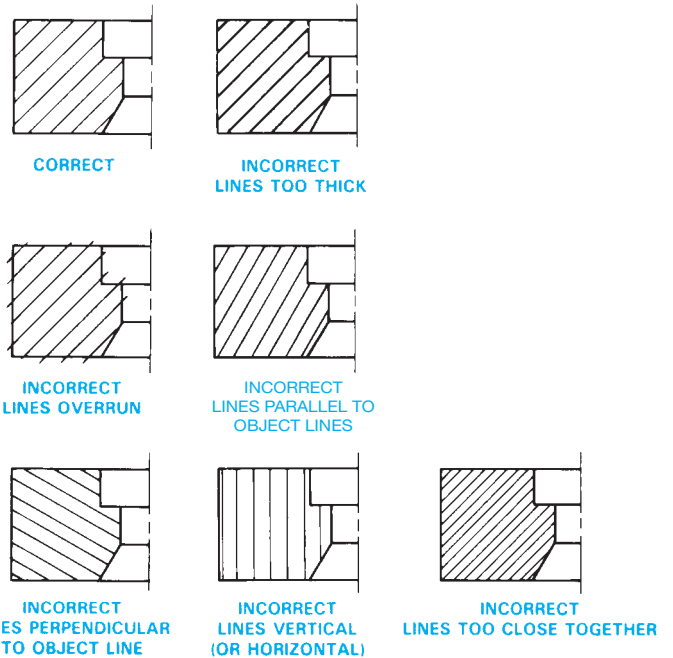


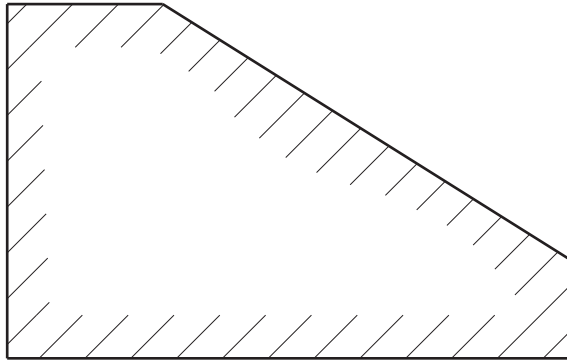
FIGURE 12.9 Common section-line errors. Notice the correct use and possible errors that can occur with improper CADD application. © Cengage Learning 2012

45° but cannot be parallel or perpendicular to any line of the object. Any convenient angle can be used to avoid placing section lines parallel or perpendicular to other lines of the object. Angles of 30° and 60° are common. Section lines that are more than 75° or less than 15° from horizontal should be avoided. Section lines must never be drawn horizontally or vertically. Figure 12.9 shows some common errors in drawing section lines. Section lines should be drawn in opposite directions on adjacent parts; when several parts are adjacent, any suitable angle can be used to make the parts appear clearly separate.

When a very large area requires section lining, you can use outline section lining as shown in Figure 12.10. Confirm the approval of this practice with your company or school before using this option.

Equally spaced section lines specify either a general material designation or cast iron and malleable iron. This method of drawing section lines is common even if the part is made out of another material because the actual material identification is normally located in the drawing title block.

General section lines are evenly spaced. The amount of space between lines depends on the size of the part. Very large parts



© Cengage Learning 2012

FIGURE 12.10 Outline section lines.

have larger spacing than very small parts (see Figure 12.11). Use your own judgment on section-line spacing related to drawing size. The space between section lines can vary depending on the size of the object, but the minimum space recommended by the ASME standard is .06 in. (1.5 mm). The key is to represent section lines so their intent is clear and obvious. Section lines can be omitted in the sectional view when drawing clarity is not affected. Confirm this practice with your supervisor or instructor. Be cautious when omitting section lines because doing so can cause confusion.

### Using Coded Section Lines

Coded section lines are used if you want to represent specific material section line symbols in the sectional view. Coded section line symbols are shown in Figure 12.12.

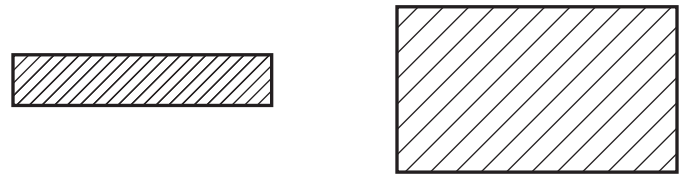
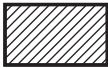
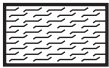
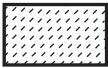

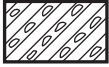




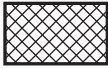
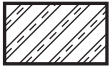
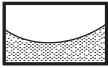

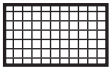


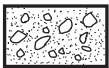

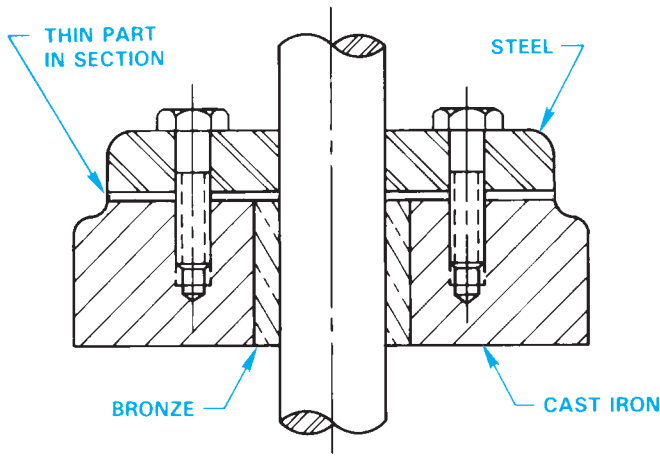


FIGURE 12.11 The space between section lines is closer together for small parts than for larger parts. © Cengage Learning 2012

		
CAST OR MALLEABLE IRON AND GENERAL USE FOR ALL MATERIALS	CORK, FELT, FABRIC, LEATHER, AND FIBER	MARBLE, SLATE, GLASS, PORCELAIN
		
STEEL	SOUND INSULATION	EARTH
		
BRONZE, BRASS, COPPER, AND COMPOSITIONS	THERMAL INSULATION	ROCK
		
WHITE METAL, ZINC, LEAD, BABBITT, AND ALLOYS	TITANIUM AND REFRACTORY MATERIAL	SAND
		
MAGNESIUM, ALUMINUM, AND ALUMINUM ALLOYS	ELECTRIC WINDINGS, ELECTROMAGNETS, RESISTANCE, ETC.	WATER AND OTHER LIQUIDS
		
RUBBER, PLASTIC, AND ELECTRICAL INSULATION	CONCRETE	ACROSS GRAIN } WOOD WITH GRAIN }

© Cengage Learning 2012

FIGURE 12.12 Coded section lines represent different materials.



**FIGURE 12.13** Assembly section, coded section lines. Each part has its own distinguishing section lines. Very thin parts such as the gasket can be drawn without section lines.

Coded section lining can be used effectively when a section is taken through an **assembly** of adjacent parts of different materials as seen in Figure 12.13. An assembly shows how the parts of a product fit together. An assembly is a grouping of one or more design components. Components can include part models and subassemblies. This is also referred to as an *assembly drawing*.

### Very Thin Features in Section

Very thin features, less than .06 in. (4 mm) thick, can be drawn without section lines. When using this practice, only the outline is drawn as shown in Figure 12.13. This option is often used for features such as the gasket shown in the Figure 12.13 assembly. Although the ASME Y14.3 standard covering sectioning applications recommends omitting section lines in thin sections, some companies prefer the practice of using solid fill on very thin sections.

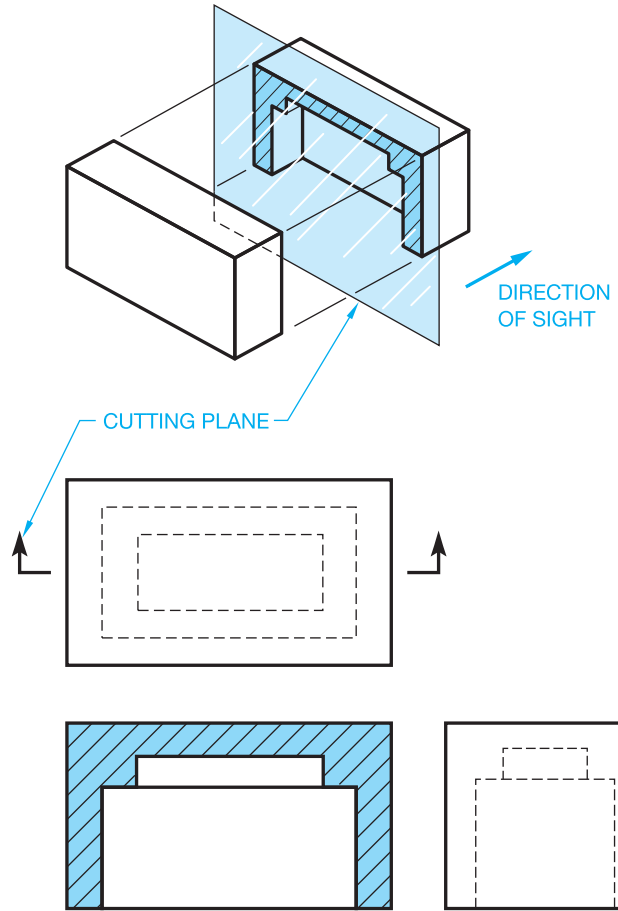
### FULL SECTIONS

A **full section** is drawn when the cutting plane extends completely through the object, usually along a center plane as shown in Figure 12.14. The object shown in Figure 12.14 could have used two full sections to further clarify hidden features. In such a case, the cutting planes and related views are labeled (see Figure 12.15). The cutting-plane line can be omitted when the relationship between views is obvious. Confirm this practice with your instructor or employer. It is normally best to show the cutting-plane line for clarity.

### HALF SECTIONS

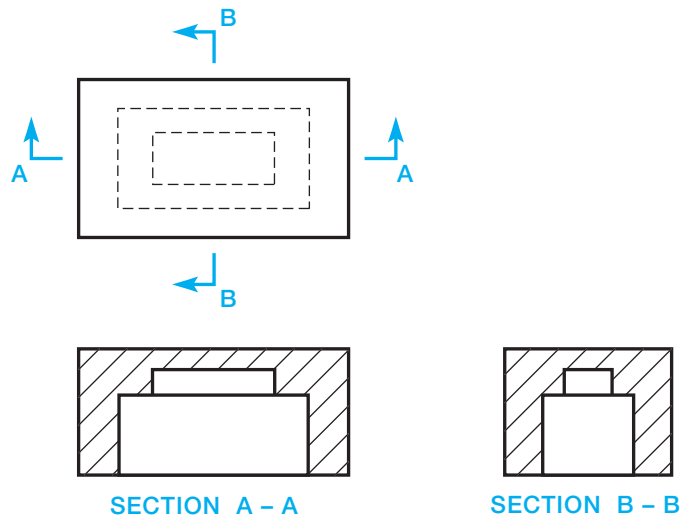
A **half section** is used when a symmetrical object requires sectioning. The cutting-plane line of a half section removes one quarter of the object. The advantage of a half section is the

© Cengage Learning 2012

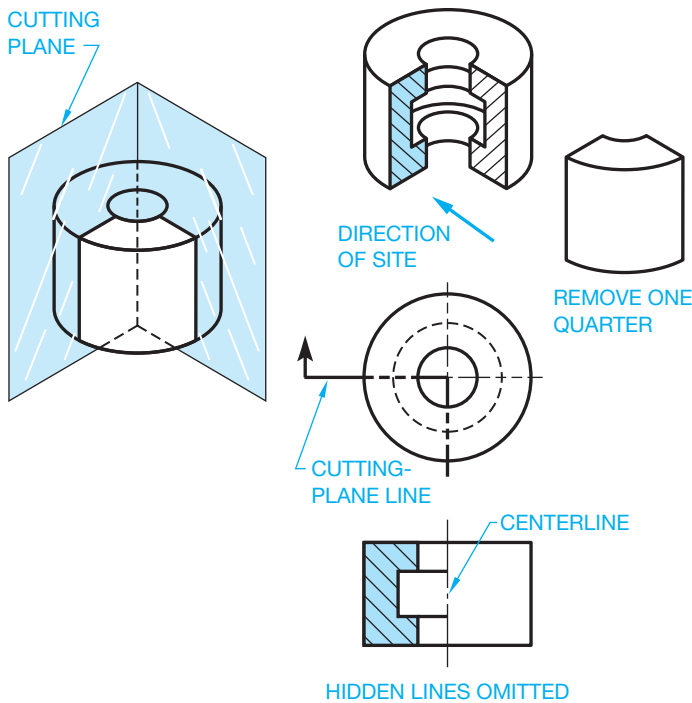


**FIGURE 12.14** Full section pictorial visualization and related views.

© Cengage Learning 2012



**FIGURE 12.15** Two full sections drawn for one part. The cutting-plane lines are labeled, and the sectional views have correlated titles. © Cengage Learning 2012

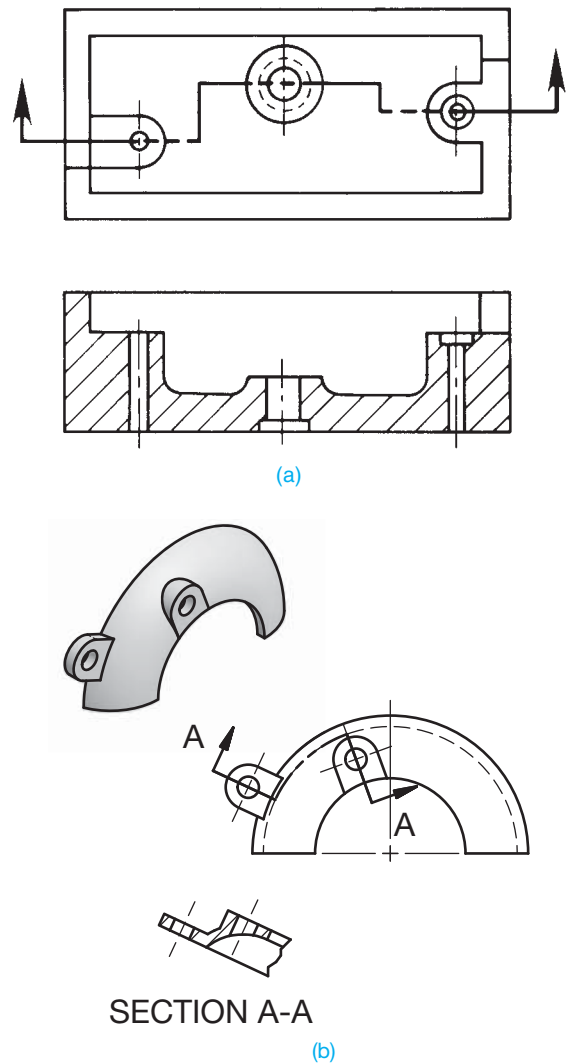


**FIGURE 12.16** Half section pictorial visualization and related views.  
© Cengage Learning 2012

sectional view shows half of the object in section and the other half of the object as it normally appears in multiview without section. The name half section comes from the idea that only half of the sectional view is sectioned (see Figure 12.16). Notice that a centerline is used in the sectional view to separate the sectioned portion from the unsectioned portion. Hidden lines are generally omitted from sectional views unless their use improves clarity.

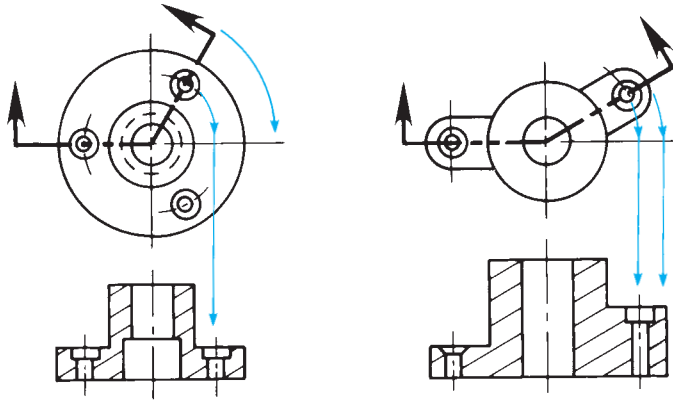
## OFFSET SECTIONS

Staggered interior features of an object are sectioned by allowing the cutting-plane line to **offset** through the features creating an **offset section** as shown in Figure 12.17. The cutting-plane line for an offset section is generally drawn using 90° turns where it offsets through the staggered features as shown in Figure 12.17a. Notice in Figure 12.17 that there is no line in the sectional view indicating a change in direction of the cutting-plane line. Normally, the cutting-plane line in an offset section extends completely through the object to display the location of the section clearly. A cutting-plane line is always used when the cutting plane is bent or offset or when the sectional view is nonsymmetrical. Figure 12.17b shows how the segments of an offset cutting plane project from and are aligned with the center when used on a circular-shaped object. The portion of the cutting-plane line between offsets is drawn as an arc, with the arc center at the center of the object.



**FIGURE 12.17** Offset section. (a) The cutting-plane line offsets using 90° turns to go through offset features on the part. (b) The segments of an offset cutting plane project from and are aligned with the center when used on a circular-shaped object. The portion of the cutting-plane line between offsets is drawn as an arc with the arc center at the center of the object.

As previously mentioned, there is no line in the sectional view of a 2-D drawing indicating the change in direction of the cutting-plane line in the adjacent view where the cutting-plane line is located. This practice can be different when creating 3-D drawings or parametric models using CADD. In this application, the CADD program may automatically create a line representing the edge where the cutting plane changes direction in the 3-D sectional view. When converting the 3-D model to a 2-D drawing, the CADD program may automatically place a line in the sectional view where the cutting-plane line changes direction in the adjacent view. If this happens, you may have to erase the unwanted lines or change the program setting to avoid having the lines displayed.



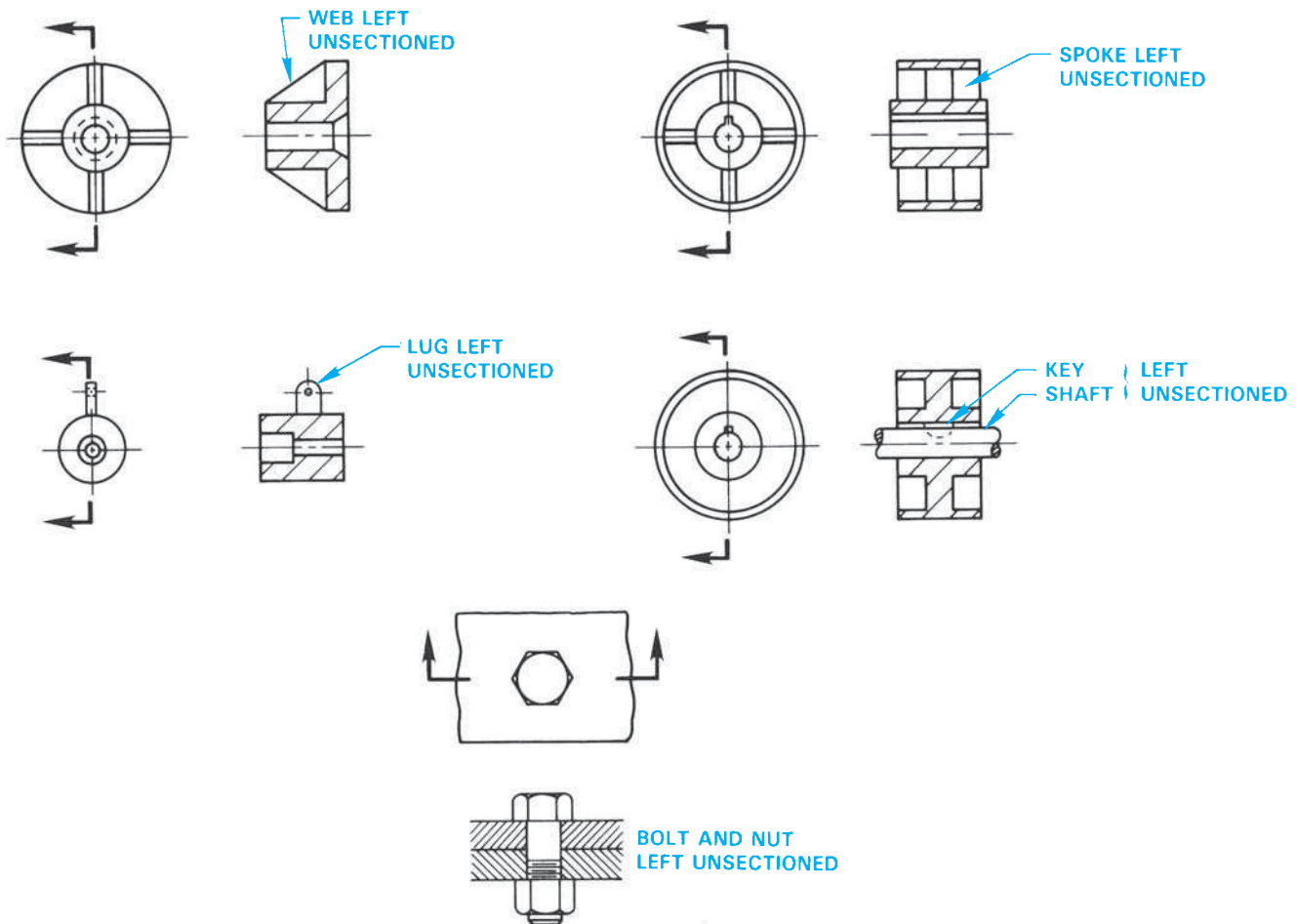
**FIGURE 12.18** Aligned section. The cutting-plane line offsets using less than 90° turns to go through offset features on the part. The cutting plane is rotated to align with the viewing plane to create the sectional view.  
© Cengage Learning 2012

### ALIGNED SECTIONS

Similar to the offset section, the **aligned section** cutting-plane line staggers to pass through offset features of an object. Normally the change in direction of the cutting-plane line is less than 90° in an aligned section. When this section is taken, the sectional view is drawn as if the cutting plane is rotated to a plane perpendicular to the line of sight as shown in Figure 12.18. A cutting-plane line is always used when the cutting plane is bent or offset or when the sectional view is nonsymmetrical.

### UNSECTIONED FEATURES

Specific features of an object are commonly left unsectioned in a sectional view if the cutting-plane line passes through and parallel to the feature. The types of features that are left unsectioned for clarity are bolts, nuts, rivets, screws, rods, shafts, ribs, webs, spokes, bearings, gear teeth, pins, and keys (see Figure 12.19).



**FIGURE 12.19** Certain features are not sectioned when a cutting plane passes parallel to their axes. These features include webs, lugs, spokes, shafts, keys, and fasteners.

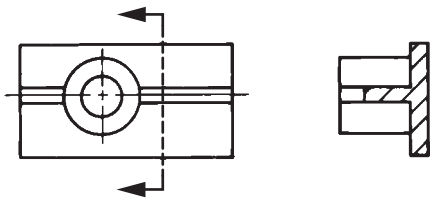


**NOTE:** The practice of leaving features unsectioned when in the plane of the cutting-plane line works well for 2-D drafting, but when using 3-D modeling ribs and webs appear sectioned. This practice can vary depending on your software application.

When the cutting-plane line passes through the previously described features perpendicular to their axes, then section lines are shown as seen in Figure 12.20.

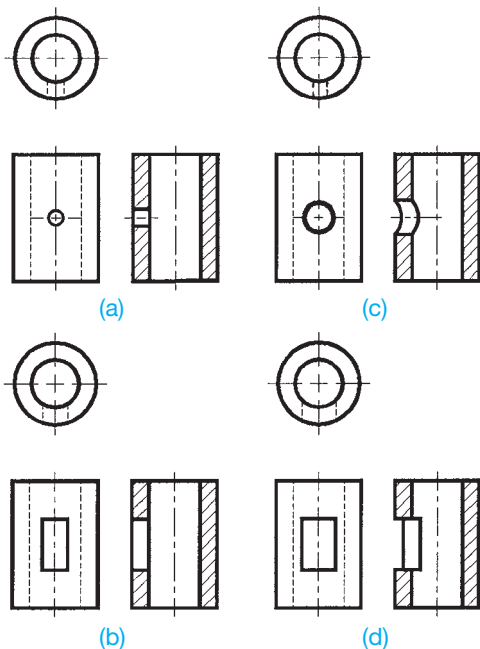
### INTERSECTIONS IN SECTION

When a section is drawn through a small intersecting shape, the true projection can be ignored if creating the fine detail takes too much time or the detail is too complex to represent (see Figure 12.21a and b). Larger intersecting features are drawn as their true geometry representation as shown in Figure 12.21c



© Cengage Learning 2012

**FIGURE 12.20** Cutting plane perpendicular to normally unsectioned features requires that the features are sectioned with section lines.



© Cengage Learning 2012

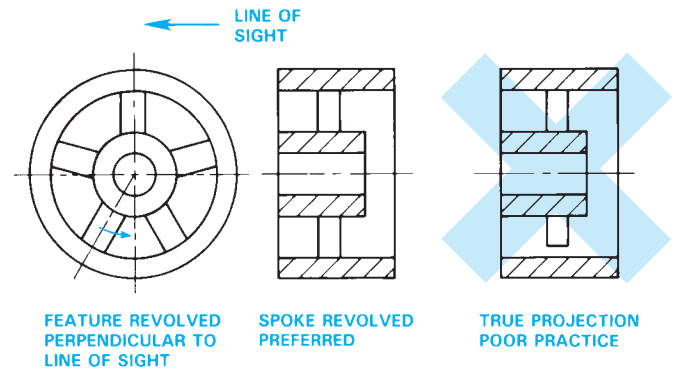
**FIGURE 12.21** Intersections in section.

and d. The professional decision is up to you. The true projection is typically automatically displayed by the CADD program, and an accurate true geometry representation is provided when using 3-D modeling.

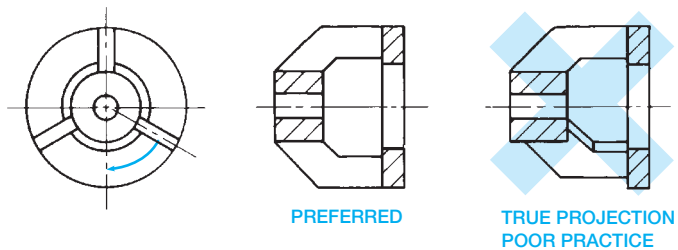
### CONVENTIONAL REVOLUTIONS

When the true projection of a feature results in foreshortening, the feature should be revolved onto a plane perpendicular to the line of sight as in Figure 12.22. The revolved spoke shown gives a clear representation. The true projection is poor practice because the spoke is foreshortened as you can see in Figure 12.22. Figure 12.23 shows another illustration of conventional revolution compared to true projection. Notice how the true projection results in a distorted and foreshortened representation of the web. The revolved web in the preferred view is clear and easy to draw. The practice illustrated here also applies to features of unsectioned objects in multiview as shown in Figure 12.24.

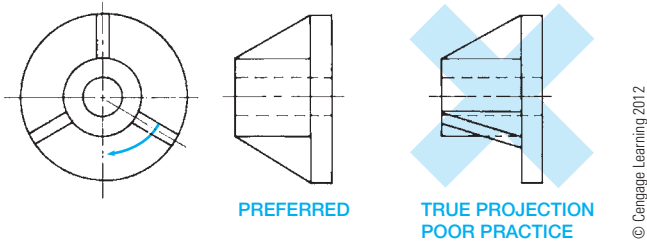
When using a 2-D CADD program such as AutoCAD, you can easily draw the conventional revolution preferred by ASME Y14.3. If the CADD program provides true projection,



**FIGURE 12.22** Conventional revolution. The preferred view has the spoke revolved to the viewing plane and then projected to the sectional view. © Cengage Learning 2012



**FIGURE 12.23** Conventional revolution in section. The preferred view has the web revolved to the viewing plane and then projected to the sectional view. © Cengage Learning 2012



**FIGURE 12.24** Conventional revolution in multiview. The preferred view has the web revolved to the viewing plane and then projected to the adjacent view.

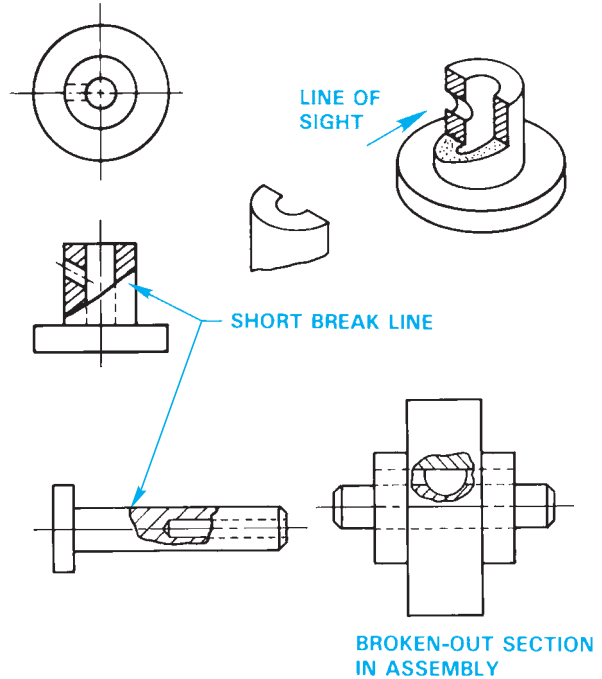
the 2-D drawing can be edited to comply with conventional revolution standards by using commands such as ROTATE. Some 3-D CADD modeling programs automatically display the true projection, and an exact representation of the object is provided. Although the true projection does not comply with ASME Y14.3 recommendations of providing conventional revolutions, it may be difficult for the CADD system to create a drawing other than true projection. Your 3-D CADD modeling program may provide two display options, such as projection and aligned. The projection option provides the true geometry projection, and the aligned option provides the preferred aligned conventional revolution practice. Most 3-D CADD modeling programs establish a parametric relationship between the 3-D model and the 2-D drawing. This parametric relationship means that any changes made to the 3-D model or the 2-D drawing automatically affects the other. Confirm the preferred application with your instructor or company.

### BROKEN-OUT SECTIONS

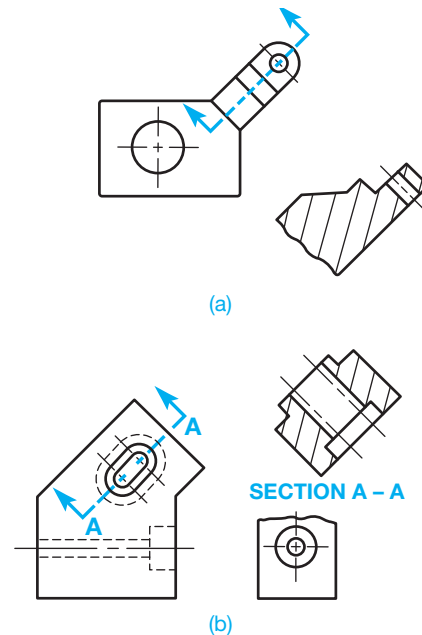
A small portion of a part can be broken away to expose and clarify an interior feature. This technique is called a **broken-out section**. The broken-out section is used when it is not necessary to section the entire view. There is no cutting-plane line used, as shown in Figure 12.25. A short break line is generally used with a broken-out section to separate the sectioned area from the unsectioned view.

### AUXILIARY SECTIONS

A section that appears in an auxiliary view is known as an **auxiliary section**. Auxiliary sections are generally projected directly from the view of the cutting plane. If these sections must be moved to other locations on the drawing sheet, they should remain in the same relationship (not rotated) as if taken directly from the view of the cutting plane (see Figure 12.26). Figure 12.17b shows an example of an offset cutting-plane line used on a circular-shaped object. The use in this drawing is also an auxiliary section application.



**FIGURE 12.25** Broken-out sections remove only a small portion of the view showing the area that requires sectioning. No cutting-plane line is used. A short break line normally separates the sectioned area from the rest of the view. © Cengage Learning 2012



**FIGURE 12.26** Auxiliary sections. (a) The auxiliary section is projected directly from the principal view. (b) The sectional view is placed in a convenient location on the sheet. The cutting plane and sectional view are correlated with letters and view title.

## SECTIONING

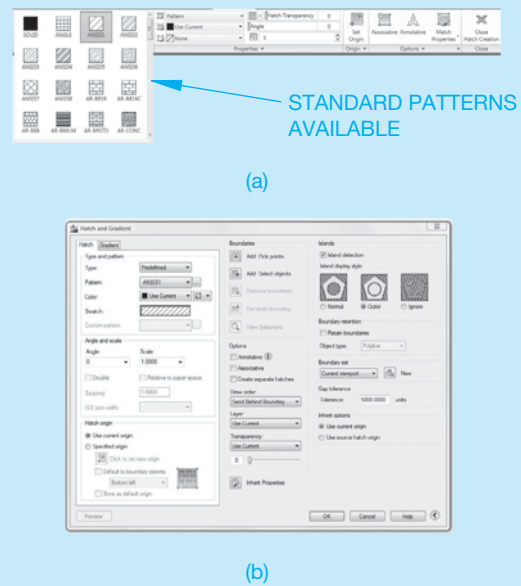
Typically, two primary steps are needed to create a sectional view using 2-D CADD software. The first step involves developing a drawing view that will act as the sectioned view. This process is identical to creating an external multiview or auxiliary view, depending on the application. Usually the only difference is that, instead of using hidden lines, you use visible object lines. If you already have a drawing view with hidden lines, you can easily transform the view into a sectional view by changing the hidden lines from a hidden line format, or layer, to a visible object layer. Once you develop sectional view geometry, the next step is to add section lines.

The power of CADD is obvious when creating section lines. CADD section lines are uniform, equally spaced, and nearly automatic to create. In addition, most CADD drafting packages have many section-line types that can be used to create even the most complex assembly sections requiring multiple section-line styles. There are standard material section lines for use on mechanical drawings, and numerous other patterns are available for architectural, structural, civil, and other engineering drafting disciplines.

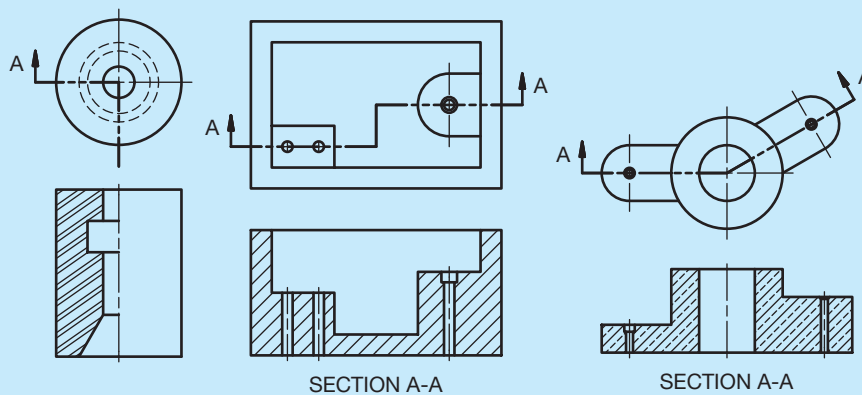
Most 2-D drafting software offers a graphic pattern tool for adding a graphic pattern, such as a pattern of section lines, or a solid fill to an area, known as a *boundary* (see Figure 12.27). The boundary is typically a closed object or group of connected objects, but some software allows for a small opening when using an appropriate gap tolerance. Review Figure 12.27 to identify boundaries associated with each view. The AutoCAD HATCH command is an example of a graphic pattern tool, and forms a single hatch object that fills an existing boundary.

The typical approach to hatching is to specify boundaries, adjust hatch properties and other settings, and then

create the hatch and exit the HATCH command. The HATCH command displays the Hatch Creation contextual ribbon tab or the Hatch and Gradient dialog box, depending on the version of AutoCAD (see Figure 12.28). The default method for placing hatch is to pick a point within a boundary and allow AutoCAD to identify the boundary (see Figure 12.29a). You also have the option to select objects in addition to or instead of internal points as shown in Figure 12.29b.



**FIGURE 12.28** (a) A portion of the AutoCAD Hatch Creation contextual ribbon tab for adding graphic patterns to boundaries. (b) The AutoCAD Hatch and Gradient dialog box for adding graphic patterns to boundaries.

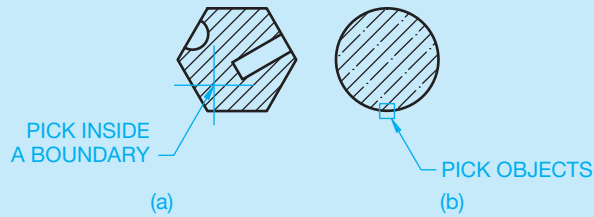


**FIGURE 12.27** Examples of sectional views with section lines created as CADD graphic patterns.

(Continued)

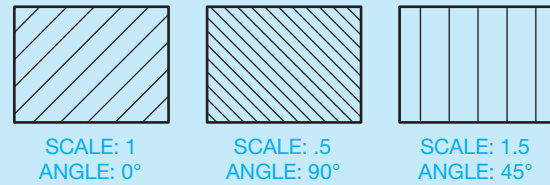


Once you specify the hatch boundary, preview the operation and adjust the hatch properties as needed. The primary hatch property is the hatch pattern. Choose the pattern or a solid fill appropriate for the application. ANSI31, for example, is effective for general use for all



**FIGURE 12.29** (a) Pick inside a closed boundary to define the area to hatch. (b) Pick objects to create a boundary to hatch. © Cengage Learning 2012

materials and cast or malleable iron. Once you choose the pattern, adjust additional properties as needed, such as pattern scale or spacing and rotation. Figure 12.30 shows examples of adjusting pattern scale and angle.

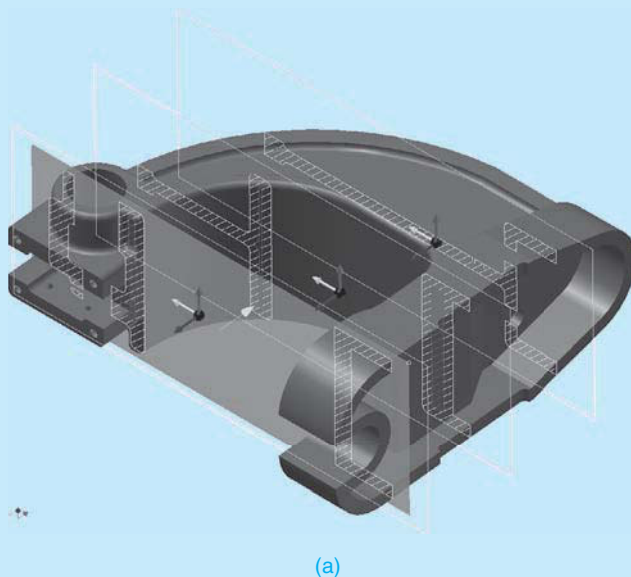


**FIGURE 12.30** Adjust hatch properties to control the display of section lines drawn using the ANSI31 hatch pattern. The default ANSI31 hatch pattern is a pattern of 45° lines .125 in. (3 mm) apart. © Cengage Learning 2012

## MODEL SECTIONS

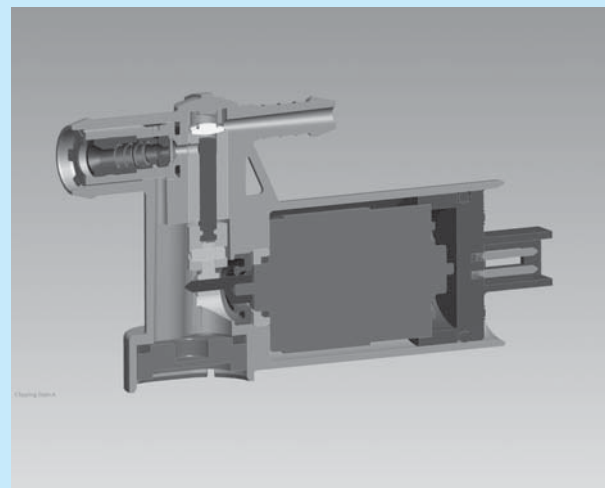
Many 3-D CADD software programs provide the ability to section a model. Sectioning a model is similar to sectioning a 2-D drawing view in that both attempt to describe the interior portions of an object that are otherwise difficult to visualize. Sectioning a model is usually a temporary display option and can be altered or turned

off at any time. You can section part or assembly models, depending on the software. Sectioning a part model is effective to help visualize the shape of internal features, as shown in Figure 12.31a. Another common application for sectioning a part model is to create sketches and features that intersect or originate from other model features.



(a)

**FIGURE 12.31** (a) Displaying several revolved sections in a 3-D part model to help visualize the internal shape of a part. (b) Sectioning a 3-D assembly model to help visualize and work with internal components.



(b)

(Continued)

Sectioning an assembly is useful for a number of applications including:

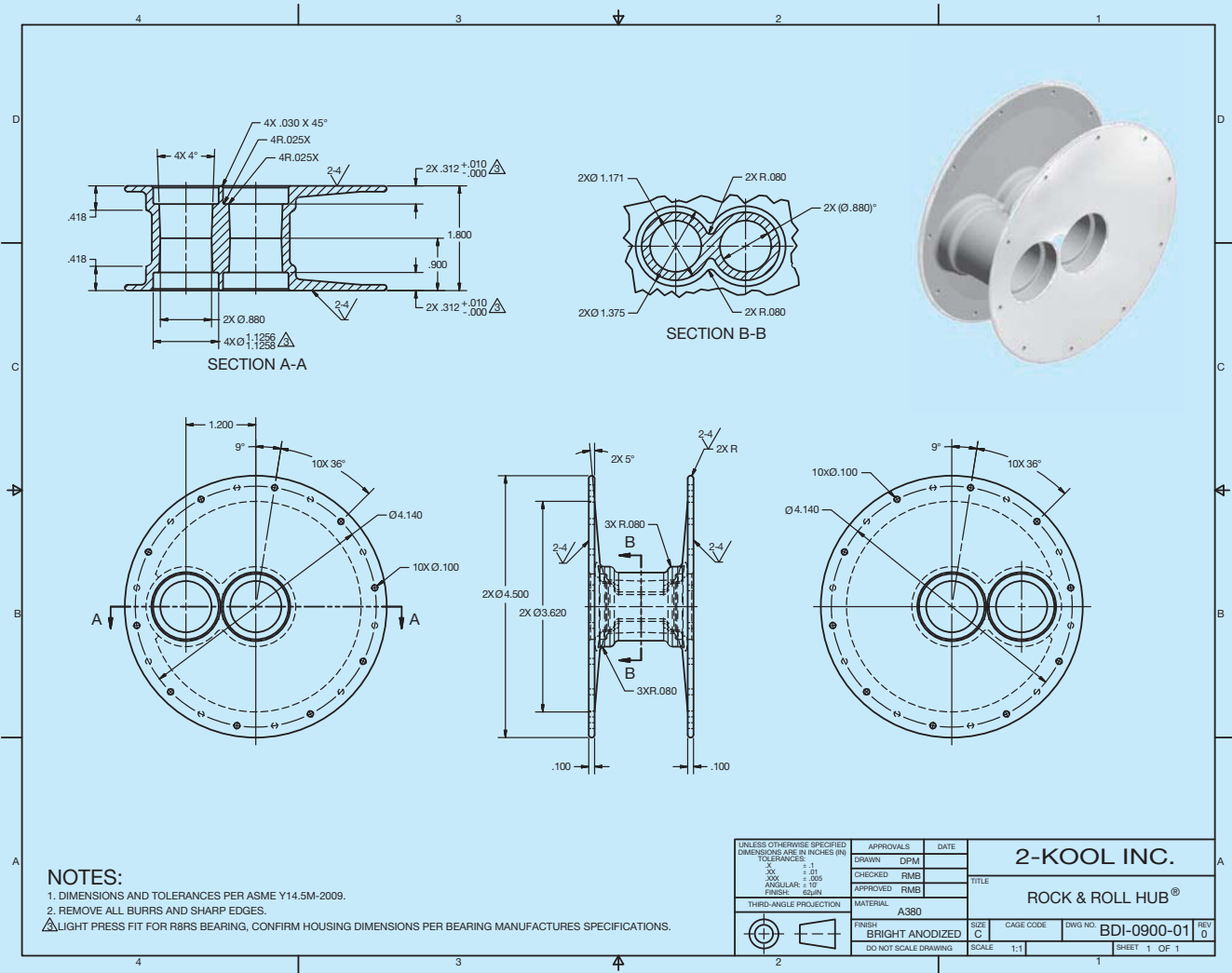
- Clearly displaying a design.
- Creating stylized model views.
- Working with complex assemblies with multiple components.
- Visualizing assembly component relationships.
- Accessing component elements when constraining existing components or creating components in-place.

Figure 12.31b shows an example of a sectioned assembly model.

### DRAWING SECTIONS

Three-dimensional CADD packages that combine 2-D drawing capabilities usually contain tools and options

that allow you to extract a variety of sectional views from a model. A tool such as SECTION VIEW allows you to create a sectional view by referencing an existing drawing view that is parametrically associated with the model. Figure 12.32 shows an example of a 2-D drawing created by taking views from a solid part model. The drawing includes principal multiviews, two section views, and a pictorial view with photorealistic material appearance and shading. Using tools like SECTION VIEW typically involves creating a cutting-plane line through a feature on an existing drawing view such as the front view. Then you pick a location for the sectional view. The new view is automatically sectioned, a cutting-plane line with arrowheads and identification letters is added, section lines are applied, and you often have the option to display a view label and scale, if appropriate.



**FIGURE 12.32** This drawing includes two sectional views, principal multiviews, and a pictorial view extracted from a 3-D solid model. The sectional views are created by referencing existing drawing views, which are parametrically associated with the model. *Courtesy 2-Kool Inc.*

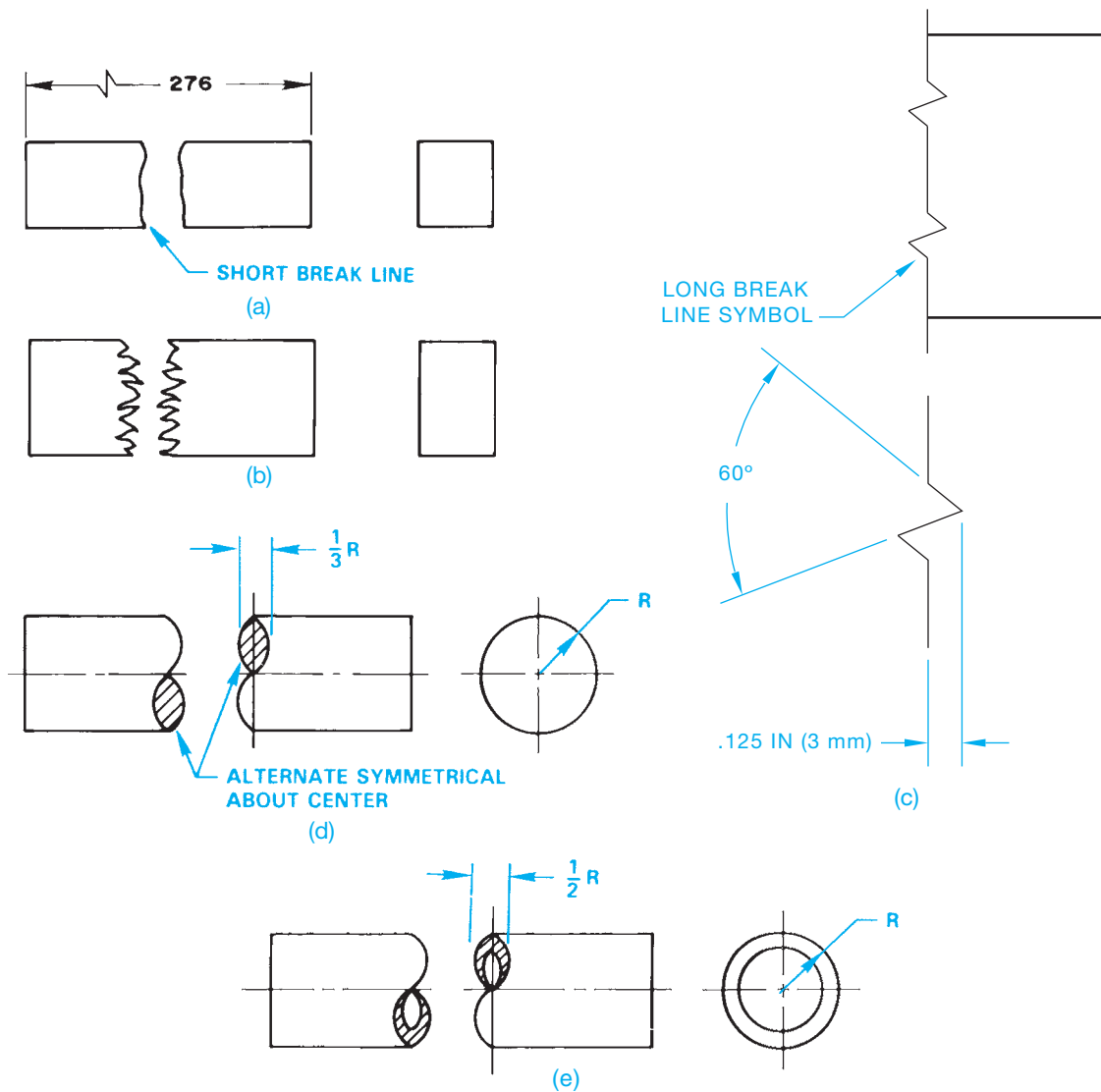
### CONVENTIONAL BREAKS

**Conventional breaks** can be used when a long object of constant shape throughout its length requires shortening to fit on a sheet or for creating a partial view. The actual length of the object is dimensioned, but a portion of the object is removed. These breaks can be used effectively to save space on the sheet, to use a smaller sheet, or to increase the scale of an otherwise very long part. Figure 12.33 shows typical conventional breaks. The short break line is commonly used in mechanical drafting and is used on metal shapes as shown in Figure 12.33a. The short break line is a thick .02 in. (0.6 mm) slightly irregular line. In Figure 12.33a, notice that the actual length dimension is given with a long break symbol placed in the dimension line to indicate that the feature has been shortened using a conventional break. When used for wood shapes, the short break line is drawn as a thick, very irregular line as shown in Figure 12.33b. The long break line is a thin

line used to create a break on a large area. The long break line has a specific break symbol placed periodically throughout the length of the line. The long break symbol should be uniformly spaced with the distance between symbols determined by the size of the drawing. Figure 12.33c shows a long break symbol application.

The break line for a solid round shape is drawn using the specific symbol shown in Figure 12.33d. The shape width should be  $\frac{1}{3}$  the radius of the feature and should be symmetrical about the horizontal centerline and the vertical guidelines as shown. Section lines are drawn on the solid round break to represent material.

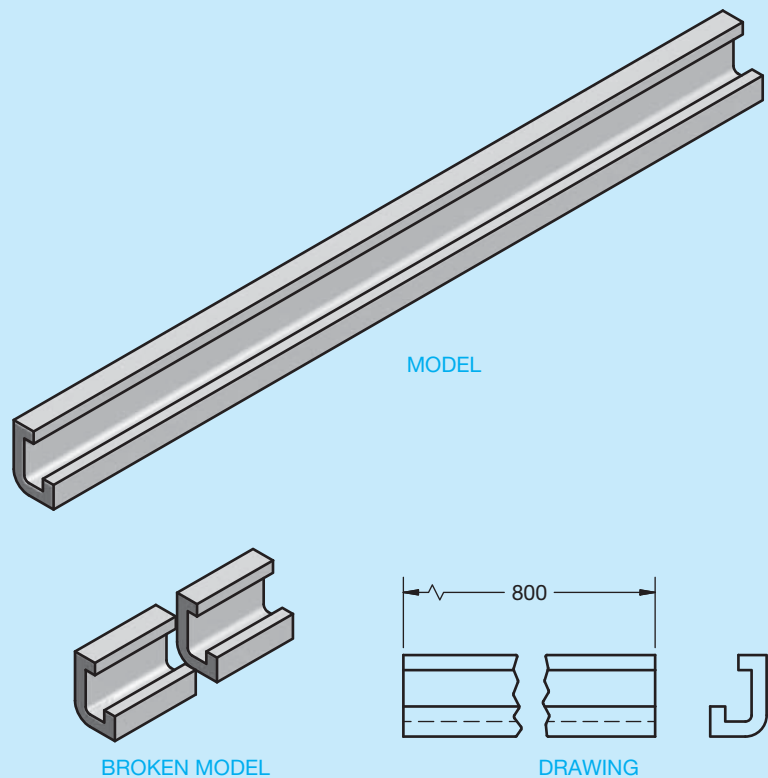
The break lines for a tubular round shape are drawn using the specific symbol shown in Figure 12.33e. The total shape width is  $\frac{1}{2}$  of the radius of the feature and is symmetrical about the horizontal centerline and vertical guidelines as shown. Section lines are drawn on the tubular round break to represent material.



**FIGURE 12.33** Conventional breaks for various shapes. (a) Short break line on metal shape. (b) Short break line on wood shape. (c) Using the long break line for large objects. (d) Break symbol for a cylindrical solid shape. (e) Break symbol for a cylindrical tubular shape.

## CONVENTIONAL BREAKS

Conventional breaks can be easily created in the 2-D drawing environment available with some 3-D CADD software programs. Tools such as **BROKEN VIEW** and **BREAK** allow you to create a conventional break by referencing an existing drawing view that is parametrically associated with the model (see Figure 12.34). A conventional break tool usually requires that you select the existing drawing view to break, such as the front view. Then define the portion of the view to break and adjust other settings, such as selecting the type, scale, and appearance of break lines. The new view breaks automatically, and the software adds break lines. Dimensions reference the actual unbroken length and typically display the appropriate symbol indicating a broken dimension value.

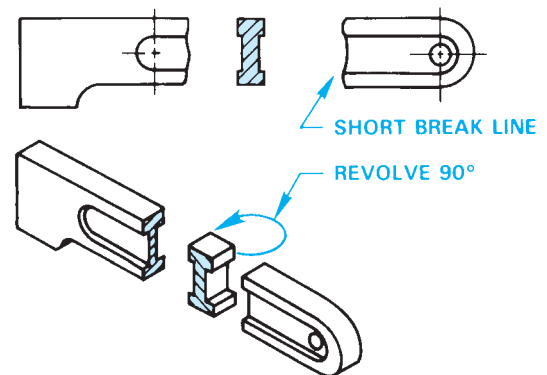


**FIGURE 12.34** Creating a conventional break by referencing an existing drawing view parametrically associated with a model. © Cengage Learning 2012

## REVOLVED SECTIONS

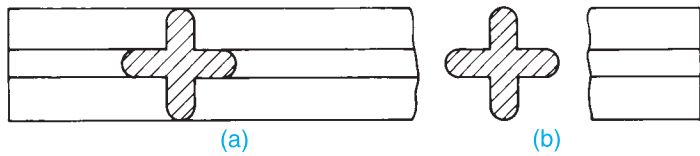
Using conventional breaks was introduced before revolved sections because conventional breaks are commonly used in combination with revolved sections. A **revolved section** can be used when a feature has a constant shape throughout the length that cannot be shown in an external view. The types of feature shapes that are common with revolved sections are extrusions, spokes, beams, and arms. The desired section is revolved  $90^\circ$  in place onto a plane perpendicular to the line of sight as shown in Figure 12.35. No cutting-plane line is used with a revolved section. Revolved sections can be represented on a drawing in one of two ways as shown in Figure 12.36. In Figure 12.36a, the revolved section is drawn on the part without breaking a portion of the part away. The revolved section can also be placed in the view with a portion of the view broken away to create an opening for the revolved section as seen in Figure 12.36b. When using this method, the surrounding space can be used for dimensions as shown in Figure 12.37.

Notice in Figure 12.37 that very thin parts, less than .016 in. (4 mm) thick, in sections can be drawn without section lines. This practice is also common when sectioning a gasket

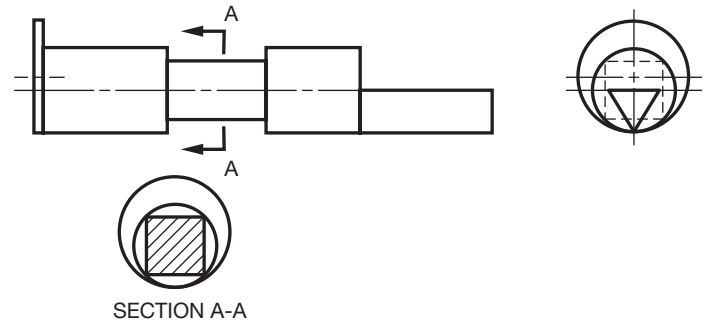


**FIGURE 12.35** Revolved section pictorial visualization and related sectional view. A portion of the object is broken away using short break lines, and the section is rotated  $90^\circ$  to the viewing plane.

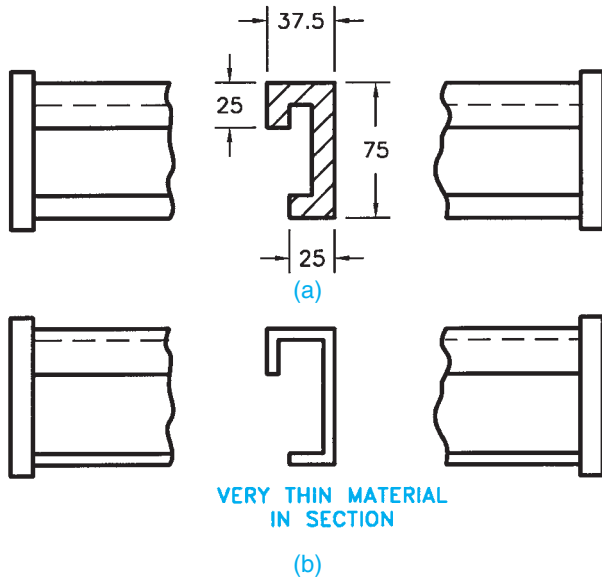
or similar feature. Although the ASME Y14.3 standard covering sectioning applications recommends omitting section lines in thin sections, some companies prefer the practice of using solid



**FIGURE 12.36** (a) Revolved section not broken away. (b) Revolved section broken away. © Cengage Learning 2012

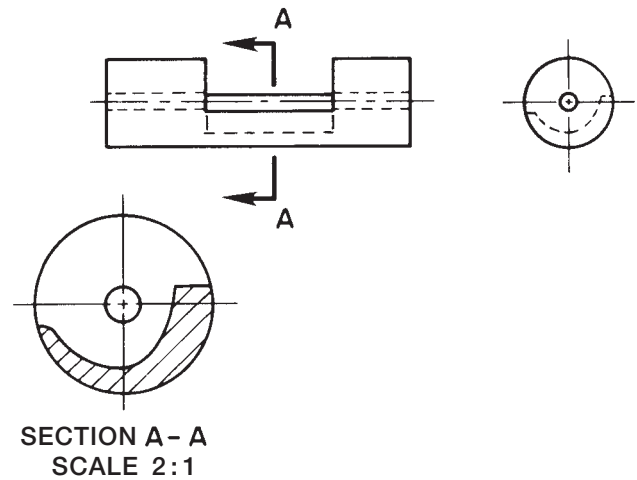


**FIGURE 12.38** Removed section. The cutting-plane line is labeled, and the sectional view can be drawn in any convenient location on the sheet. The sectional view has a title that correlates with the cutting-plane line. © Cengage Learning 2012



**FIGURE 12.37** (a) Dimensioning a broken-away revolved section. (b) A revolved section through thin material less than .016 in. (4 mm) thick can be drawn without section lines.

© Cengage Learning 2012



**FIGURE 12.39** Enlarged removed section. The removed section scale can be increased to show detail. The sectional view scale is placed below the title.

© Cengage Learning 2012

fill on very thin sections. Confirm whether this practice is acceptable with your school or company standards.

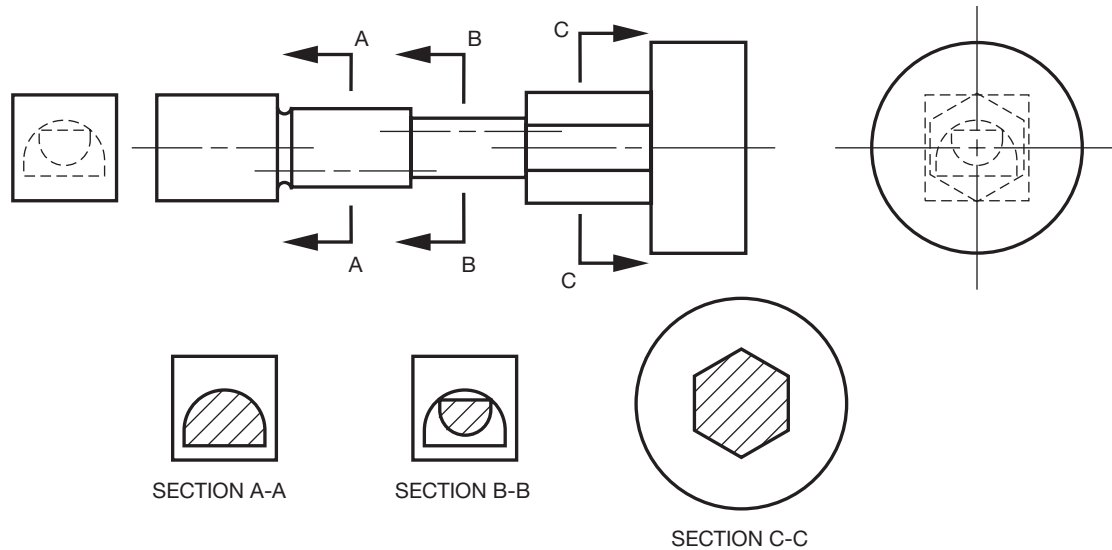
## REMOVED SECTIONS

**Removed sections** are similar to revolved sections except they are removed from the view. A cutting-plane line is placed through the object where the section is taken. Removed sections are not generally placed in direct alignment with the cutting-plane line but are placed in a surrounding area as shown in Figure 12.38. The cutting-plane line is labeled with letters such as AA for the first removed section and BB for the second removed section. The cutting-plane line in Figure 12.39 is labeled AA, and the removed section is placed in any desired location on the drawing. The title SECTION A-A is placed below the sectional view.

Removed sections are usually preferred when a great deal of detail makes it difficult to use a revolved section

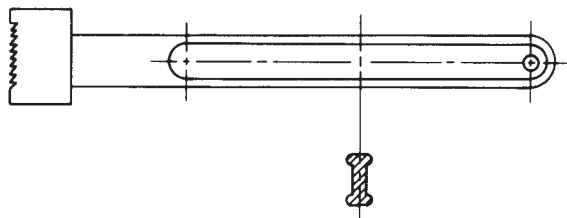
effectively. An additional advantage of the removed section is that it can be drawn to a larger scale so close detail can be more clearly identified as shown in Figure 12.39. The sectional view should be labeled with SECTION A-A and the scale placed below the view as shown in Figure 12.39. The predominant scale of the principal views is shown in the title block.

Multiple removed sections are generally arranged on the sheet in alphabetical order from left to right and top to bottom (see Figure 12.40). The cutting planes and related sections are labeled alphabetically. The only letters that should not be used for labeling sections are I, O, Q, S, X, and Z because they can be mistaken for numbers. When the entire alphabet has been used, label your sections with double letters beginning with AA-AA, AB-AB, AC-AC, and so on.



**FIGURE 12.40** Multiple removed sections. Hidden lines in the right- and left-side views help illustrate the importance of section views. Multiple removed sections are placed in alphabetical order from left to right and top to bottom.

© Cengage Learning 2012



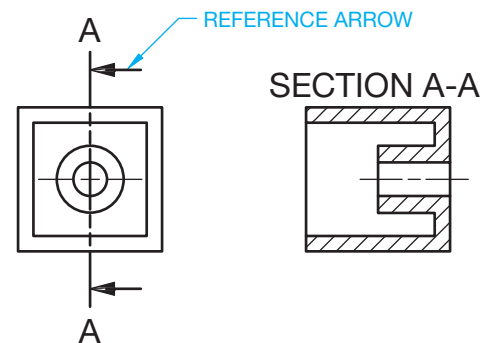
© Cengage Learning 2012

**FIGURE 12.41** Alternate removed section method. A centerline extends from the view, and the revolved section is rotated 90° and placed on the centerline.

Another method of drawing a removed section is to extend a centerline adjacent to a symmetrical feature and revolve the removed section on the centerline as shown in Figure 12.41. The removed section can be drawn at the same scale or enlarged as necessary to clarify detail.

### Reference Arrow Method for Sectional View Identification

An alternate technique for placing the cutting-plane lines is called the **reference arrow method**. When using the reference arrow method for identifying sections, arrowheads point toward each end of the cutting-plane line, and the section identification letters are placed at the ends of the cutting-plane line. The view title is placed above the removed section when using the removed arrow method (see Figure 12.42).



© Cengage Learning 2012

**FIGURE 12.42** Using the reference arrow method for creating a removed section. The ends of the cutting plane are labeled with letters and arrows point in the viewing direction. The view title is placed above the correlated sectional view.

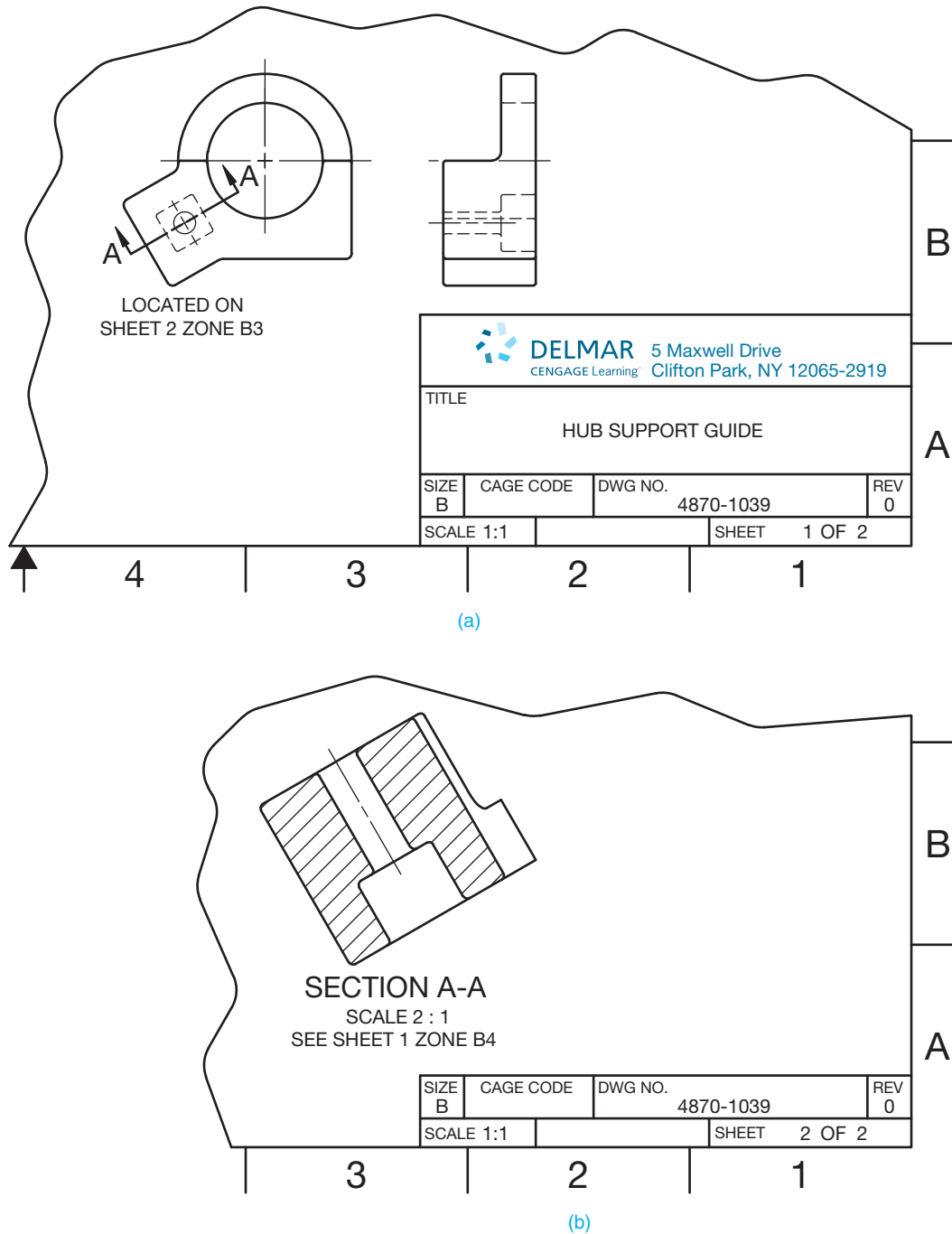
### LOCATING SECTIONAL VIEWS ON DIFFERENT SHEETS

This chapter has described the various methods used for displaying cutting-plane lines and related sectional views. The preferred method is to project the sectional view directly from and perpendicular to the cutting plane. Alternately, you can place labeled cutting-plane lines where needed and locate the related sections in another place on the same sheet. When

using this method, each section has a title correlated to the cutting-plane lines.

When necessary, locate sectional views on a sheet other than where the cutting-plane lines appear. The method for doing this is called **cross-reference zoning**, and it is used to indicate the location of a section back to the viewing location on a previous page. The sectional view is located on a

different page and is labeled with the sheet number and zone of the cross-reference cutting plane as shown in Figure 12.43. ASME Y14.3 does not recommend a specific zone and page identification system. The cutting plane and sectional views should have a note correlating each between sheets as shown in Figure 12.43.



**FIGURE 12.43** Cross-reference zoning is used to indicate the location of a section back to the viewing location on a previous page. (a) The sheet where the cutting plane is located. (b) The sheet where the sectional view is located.

## RECOMMENDED REVIEW

It is recommended that you review the following parts of Chapter 7 before you begin working on fully dimensioned sectioning drawings. This will refresh your memory about how related lines are properly drawn.

- Object lines.
- Viewing planes.
- Extension lines.
- Hidden lines.
- Break lines.
- Dimension lines.
- Centerlines.
- Phantom lines.
- Leader lines.

Study these Chapter 7 topics more carefully as they are related directly to sectioning practices:

- Cutting planes.
- Section lines.
- Coded section lines.

In addition, review Chapters 8 and 9 covering multiview and auxiliary view drawings and Chapter 10 for recommended dimensioning practices.

## PROFESSIONAL PERSPECTIVE

Your role as an engineering drafter is communication. You are the link between the engineer and manufacturing, fabrication, or construction. Up to this point, you have learned a lot about how to perform this communication task, but the hard part comes when you have to apply what you have learned. Your goal is to make every drawing clear, complete, and easy to interpret. There are many factors to consider, including:

- Selection of the front view and related views.
- Deciding whether sections are to be used.
- Placement of dimensions in a logical format so the size description and located features are complete.

This is a difficult job, but you are motivated and enjoy the challenge. Just when you have mastered how to select and dimension multiviews, you are faced with preparing sectional drawings, which means a selection from many options and applications. The following are some key points to consider:

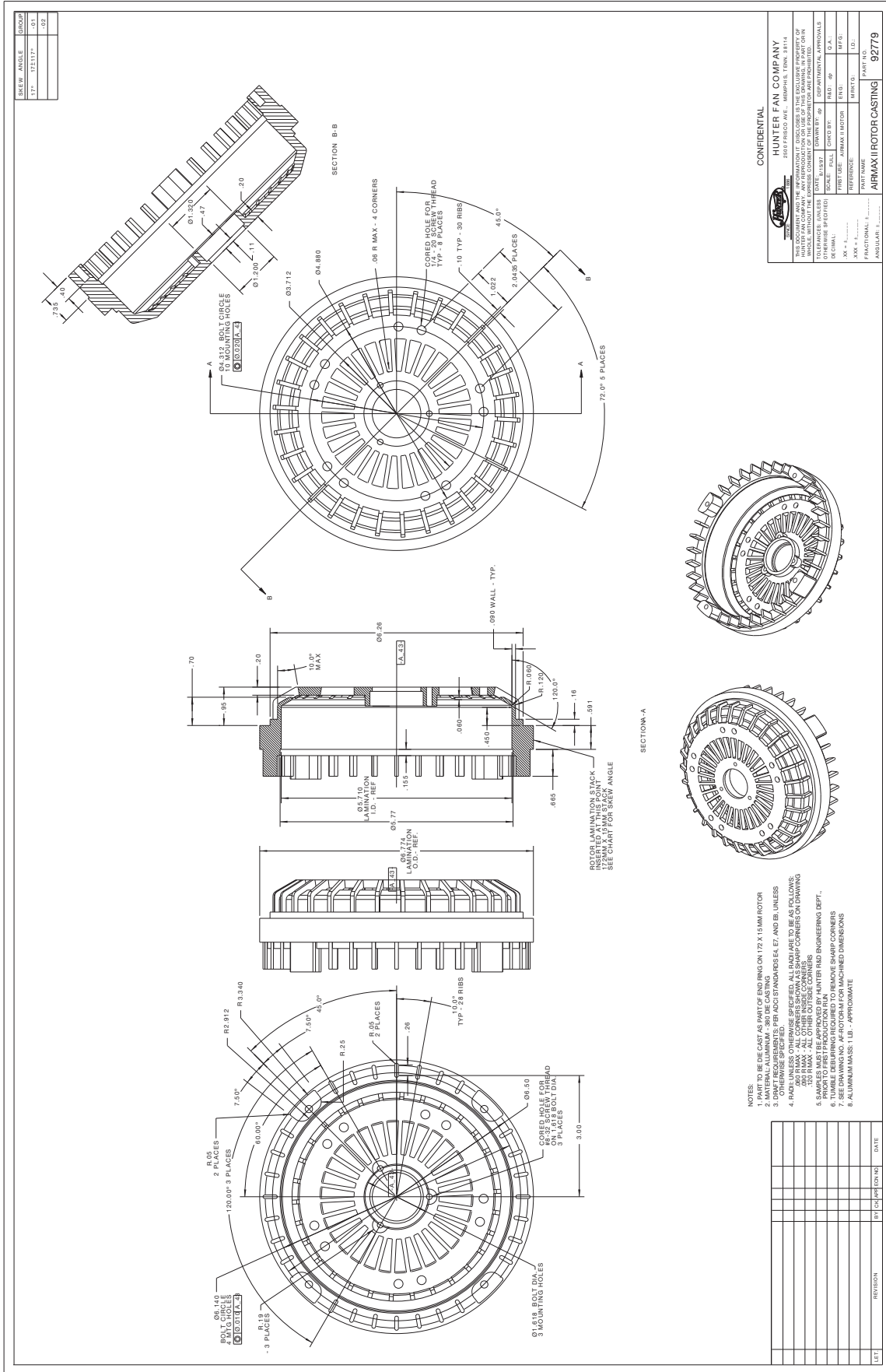
- First, you need to completely show and describe the outside of the part.
- If there are many hidden lines for internal features, you know immediately that a section is needed because you cannot dimension to hidden lines.

- Analyze the hidden lines.
- Review each type of sectioning technique until you find one that looks best for the application.
- Be sure you clearly label the cutting-plane lines and related multiple sections so they correlate.
- Half sections are good for showing both the outside and inside of the object at the same time, but half sections are used only on symmetrical parts. Half sections have a purpose, but be cautious about their use, because they can confuse the reader.

You are not alone in this new venture. The problem assignments in this chapter recommend a specific sectioning technique during your learning process.

Figure 12.44 shows a carefully created drawing of a complex part. Along with front, left-side, and rear views, there is a full section and auxiliary section. Spend some time looking at this drawing and try to imagine the thought process used by the drafter. Find and review as many actual industry drawings as you can in to better understand view and section selection.

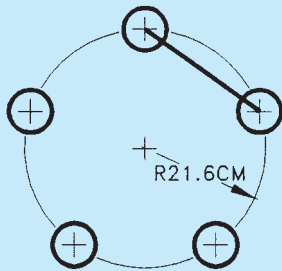




**FIGURE 12.44** An actual industry drawing of a complex part, using front, left-side, and rear views along with a full and auxiliary section. Courtesy Hunter Fan Company

## DISTANCE BETWEEN HOLES ON A BOLT CIRCLE

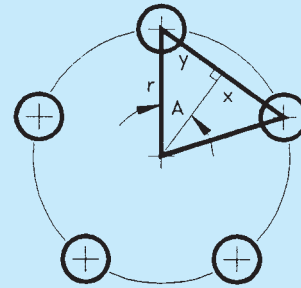
**Problem:** Find the center-to-center distance between adjacent holes on the bolt circle shown in Figure 12.45.



© Cengage Learning 2012

**FIGURE 12.45** Finding the center-to-center distance between holes in a bolt circle.

**Solution:** Problems like this involve finding the side of a right triangle. The first step is to construct a right triangle onto the drawing, as shown in Figure 12.46. From the definition of *sine*. (See Math Instruction Appendix in the Online Companion.)



© Cengage Learning 2012

**FIGURE 12.46** Bolt circle with a right triangle drawn.

From the definition of *sine* (see CD Chapter 3):

$$\sin A = \frac{y}{r}$$

Because there are five holes on the circle, angle A must be  $(\text{half of } 360^\circ) \div 5$ , or  $36^\circ$ . Hypotenuse r is equal to the radius of 21.6 cm, so you now have  $\sin 36^\circ = \frac{y}{21.6}$ . Using a y calculator to find the sine of  $36^\circ$  gives  $.5878 = \frac{y}{21.6}$ .

Multiplying both sides of this equation by 21.6 gives the length of side y of the triangle:  $y = (21.6) (.5878) = 12.696$ . Finally, side y is half of the required center-to-center distance, so  $d = 2(12.696) = 25.4 \text{ cm}$ .



### Engineering Drawing and Design Math Applications

For definitions and information about trigonometry functions, go to the Student CD, select **Reference Material**, and then **Engineering Drawing and Design Math Applications**.

### WEB SITE RESEARCH

Use the following Web sites as a resource to help find more information related to engineering drawing and design and the content of this chapter.

Address	Company, Product, or Service
<a href="http://www.asme.org">www.asme.org</a>	American Society of Mechanical Engineers (ASME)
<a href="http://www.iso.org">www.iso.org</a>	International Organization for Standardization
<a href="http://www.adda.org">www.adda.org</a>	American Design Drafting Association and American Digital Design Association (ADDA International)

## Chapter 12

## Chapter 12 Sections, Revolutions, and Conventional Breaks Test



To access the Chapter 12 test, go to the Student CD, select **Chapter Tests and Problems**, and then **Chapter 12**. Answer the questions

with short, complete statements, sketches, or drawings as needed. Confirm the preferred submittal process with your instructor.

# Chapter 12 Sections, Revolutions, and Conventional Breaks Problems

## INSTRUCTIONS

### Part 1: Problems 12.1 Through 12.4



To access the Chapter 12 problems, go to the Student CD, select **Chapter Tests and Problems** and **Chapter 12**, and then open the problem of your choice or as assigned by your instructor. Solve the problems using the instructions provided on the CD, unless otherwise specified by your instructor.

### Part 2: Problems 12.5 Through 12.13

1. From the selected engineer's sketch or layout, determine the needed views and sections.
2. Make a sketch of the selected views and sections as close to correct proportions as possible. Do not spend a lot of time because the sketch is only a guide. Indicate cutting-plane lines and dimension placement.
3. Using your sketch as a guide, draw all of the necessary multiviews and sectional views necessary to describe the part completely. Prepare the drawing on an adequately sized ASME sheet with border and sheet block. Select a scale that properly details the part on the selected sheet size. Use unidirectional dimensioning.
4. Include the following general notes at the lower left corner of the sheet .5 in. each way from the corner border lines:
  1. DIMENSIONS AND TOLERANCES PER ASME Y14.5-2009.
  2. REMOVE ALL BURRS AND SHARP EDGES.
  3. UNSPECIFIED TOLERANCES:

Use the following for tolerances for unspecified inch values. A tolerance block is recommended as described in Chapter 2, *Drafting Equipment, Media, and Reproduction Methods*, and as shown in problems for Chapter 10, *Dimensioning and Tolerancing*, unless otherwise specified.

#### UNSPECIFIED TOLERANCES

DECIMALS	IN
X	$\pm .1$
XX	$\pm .01$
XXX	$\pm .005$
ANGULAR	$\pm 30'$
FINISH	125 $\mu\text{in.}$

For metric drawings, provide a general note that states: TOLERANCES FOR UNSPECIFIED DIMENSIONS COMPLY

WITH ISO 2768-m. Provide a general note that states SURFACE FINISH 3.2  $\mu\text{m}$  UNLESS OTHERWISE SPECIFIED.

4. The engineering layouts may not be dimensioned properly. This is similar to what you can expect in industry. You cannot assume that what the engineer gives you complies with the drafting standards described throughout this textbook. Verify the correct practice before placing dimensions. For example, the diameter symbol should precede the diameter dimension, and leaders should not cross over dimension lines. Check other line and dimensioning techniques for proper standards. Actual industry drawings are provided as advanced problems throughout.



**NOTE:** Additional notes may be required, depending on the specifications of each individual assignment.



## Drafting Templates

To access CADD template files with predefined drafting settings, go to the Student CD, select **Drafting Templates**, and then select the appropriate template file. Use the templates to create new designs, as a resource for drawing and model content, or for inspiration when developing your own templates. The ASME-Inch and ASME-Metric drafting templates follow ASME, ISO, and related mechanical drafting standards. Drawing templates include standard sheet sizes and formats and a variety of appropriate drawing settings and content. You can also use a utility such as the AutoCAD DesignCenter to add content from the drawing templates to your own drawings and templates. Consult with your instructor to determine which template drawing and drawing content to use.

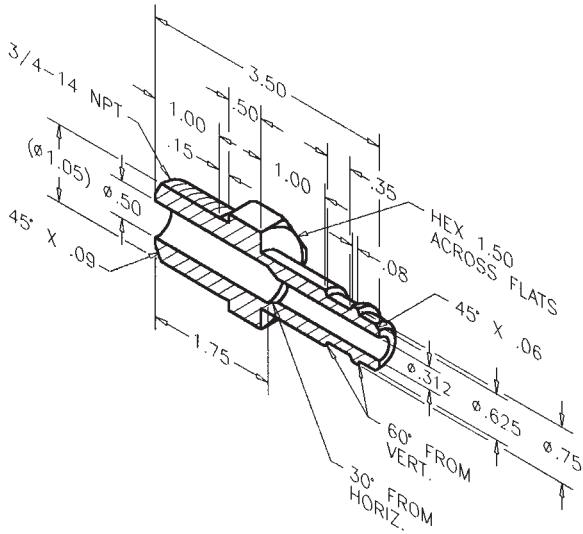
### PROBLEM 12.5 Full section (in.)

Part Name: Fitting

Material: Bronze

Finish All Over: 63  $\mu\text{in.}$

Refer to Chapter 10, *Dimensioning and Tolerancing*, for proper dimensioning practices. Engineering sketches may not display correct practices. This problem may require a front view, side view showing the hexagon, and a full section to expose the interior features for dimensioning.



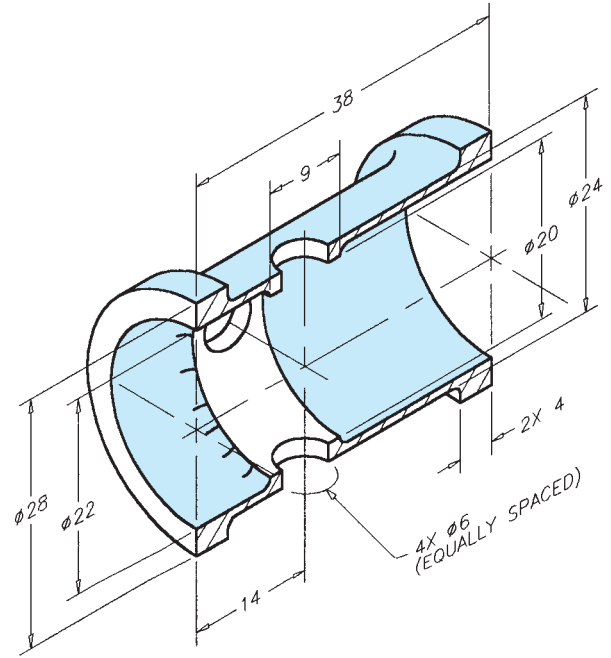
© Cengage Learning 2012

**PROBLEM 12.7 Full section (metric)**

Part Name: Hydraulic Valve Cylinder

Material: Phosphor bronze

All Fillets and Rounds: R.1



© Cengage Learning 2012

**PROBLEM 12.6 Full section and view enlargement (in.)**

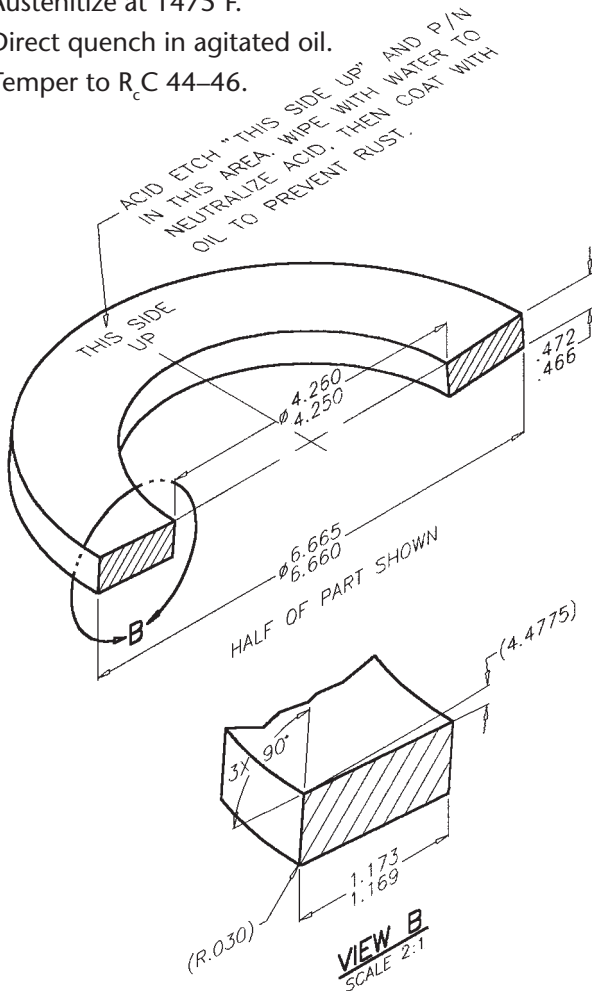
Part Name: Spring

Material: SAE 1060

Problem based on original art courtesy Stanley Hydraulic Tools, Division of The Stanley Works.

Heat-treat:

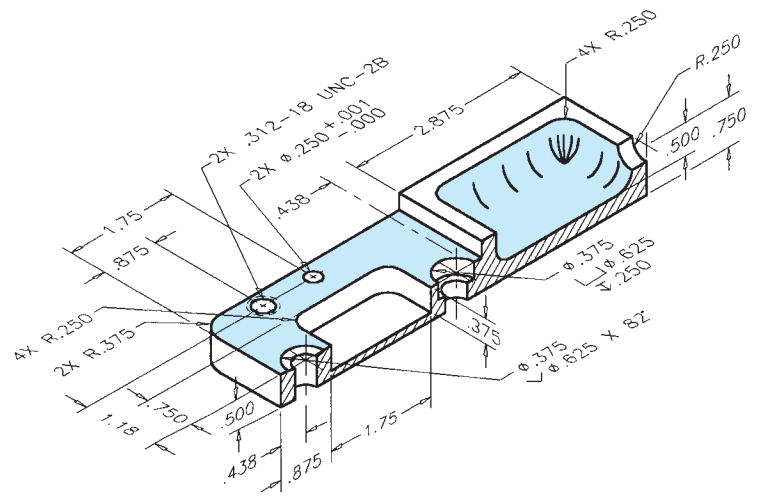
1. Austenitize at 1475°F.
2. Direct quench in agitated oil.
3. Temper to  $R_c$  44–46.



**PROBLEM 12.8 Full section (in.)**

Part Name: Machine Plate

Material: 6160 T6 steel

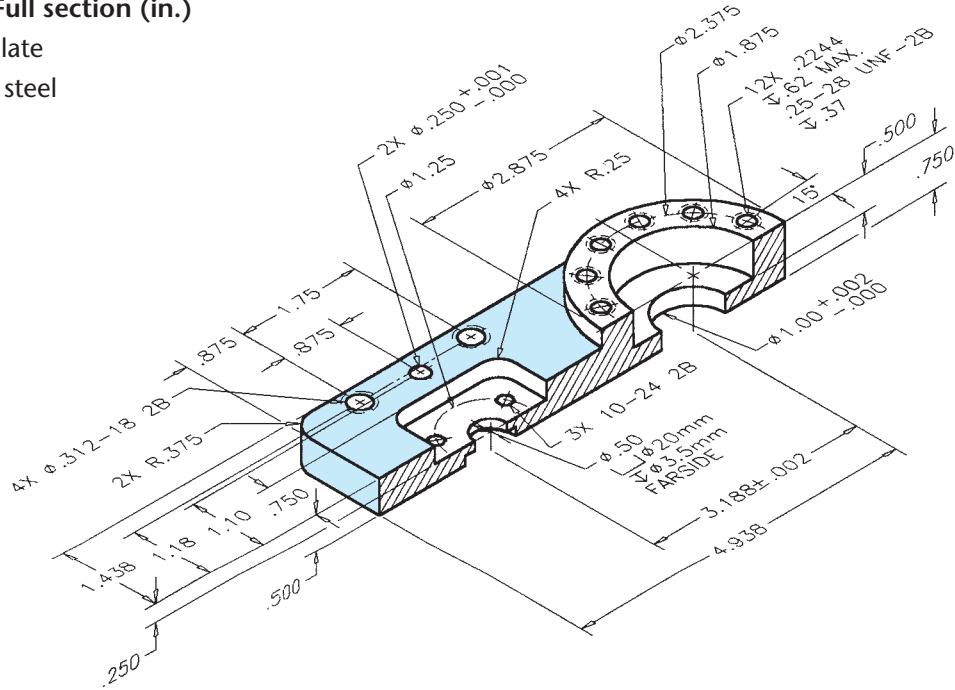


© Cengage Learning 2012

**PROBLEM 12.9 Full section (in.)**

Part Name: Face Plate

Material: 6160 T6 steel

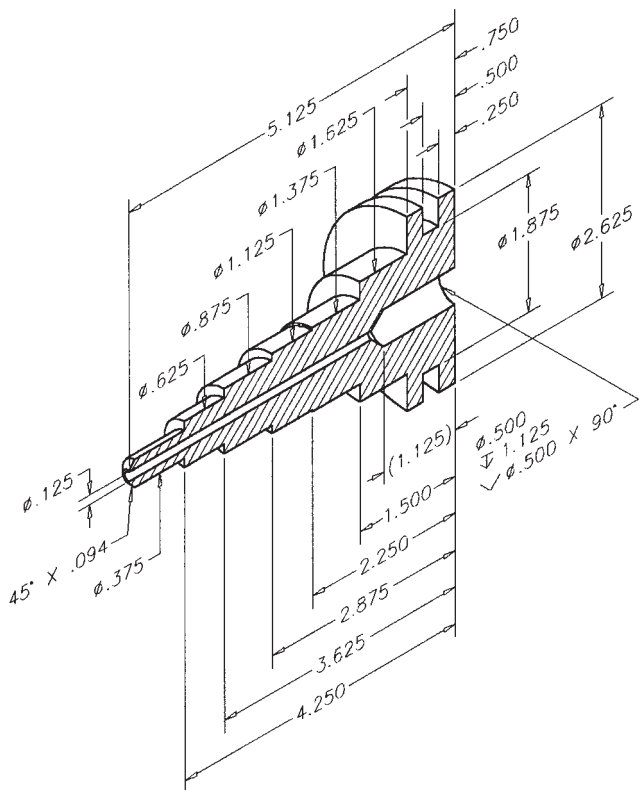


© Cengage Learning 2012

**PROBLEM 12.10 Full section, dimensioning cylindrical shapes (in.)**

Part Name: Plug

Material: Phosphor bronze



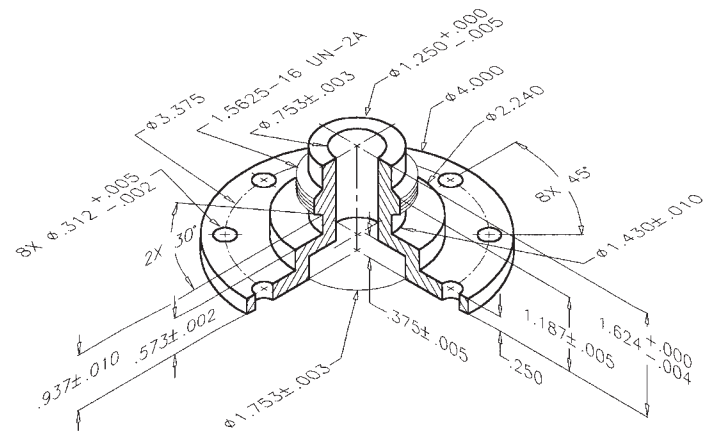
© Cengage Learning 2012

**PROBLEM 12.11 Full section or half section (in.)**

Part Name: Hub

Material: Cast iron

SPECIFIC INSTRUCTIONS: Convert the broken-out section in the given drawing to a full section. Type of section used affects view selection.



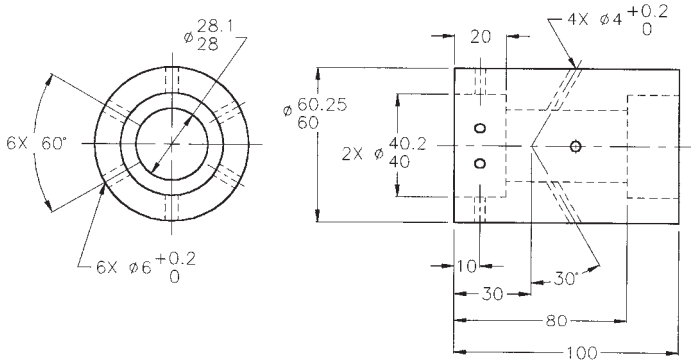
© Cengage Learning 2012

**PROBLEM 12.12 Full and broken-out section (metric)**

Part Name: Hydraulic Valve Cylinder

Material: Phosphor bronze

Proposed sections and section lines are not given in engineer's layout. Refer to "The Engineering Design Application" at the beginning of this chapter.



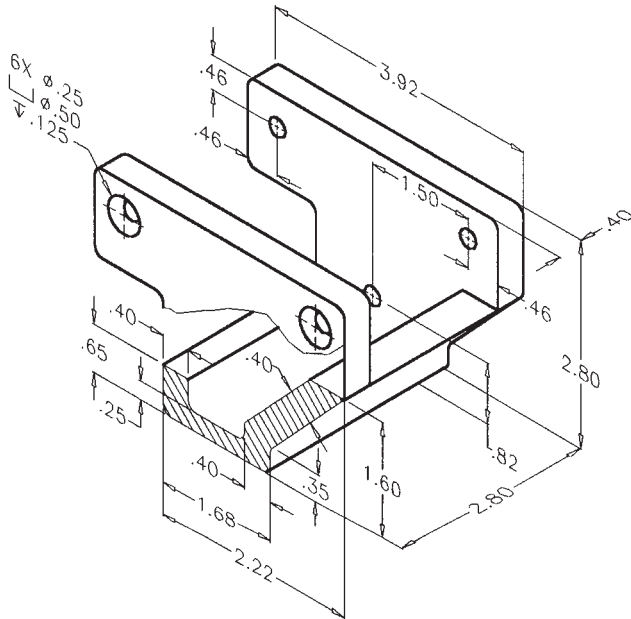
© Cengage Learning 2012

**PROBLEM 12.13 Full section (in.)**

Part Name: Hanger

Material: SAE 1030

Fillets and Rounds: R.062



**Part 3: Problem 12.14**



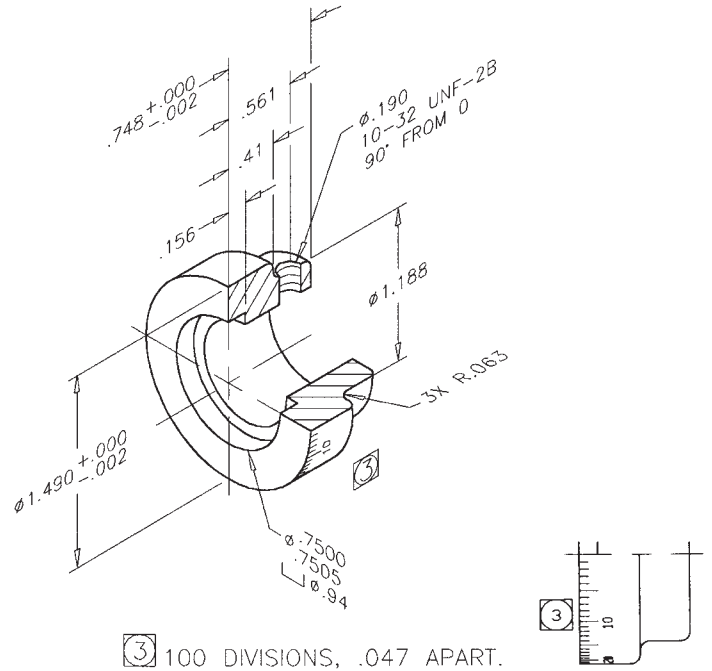
To access the Chapter 12 problems, go to the Student CD, select **Chapter Tests and Problems** and **Chapter 12**, and then open the problem of your choice or as assigned by your instructor. Solve the problems using the instructions provided on the CD, unless otherwise specified by your instructor.

**Part 4: Problems 12.15 and 12.16**

**PROBLEM 12.15 Half section (in.)**

Part Name: Dial

Material: Bronze



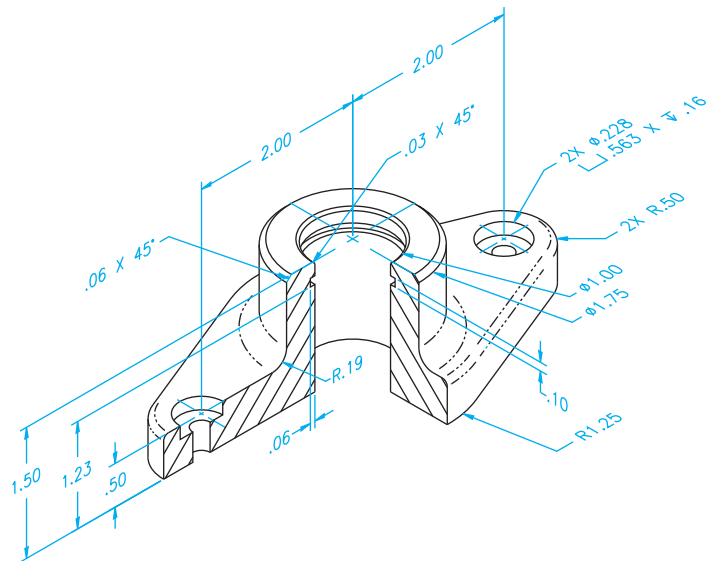
© Cengage Learning 2012

**PROBLEM 12.16 Half section (in.)**

Part Name: Rod Support


Material: 6061-T6 aluminum

Fillets: R.03 unless otherwise specified.



© Cengage Learning 2012

**Part 5: Problems 12.17 Through 12.19**

 To access the Chapter 12 problems, go to the Student CD, select **Chapter Tests and Problems** and **Chapter 12**, and then open the problem of your choice or as assigned

by your instructor. Solve the problems using the instructions provided on the CD, unless otherwise specified by your instructor.

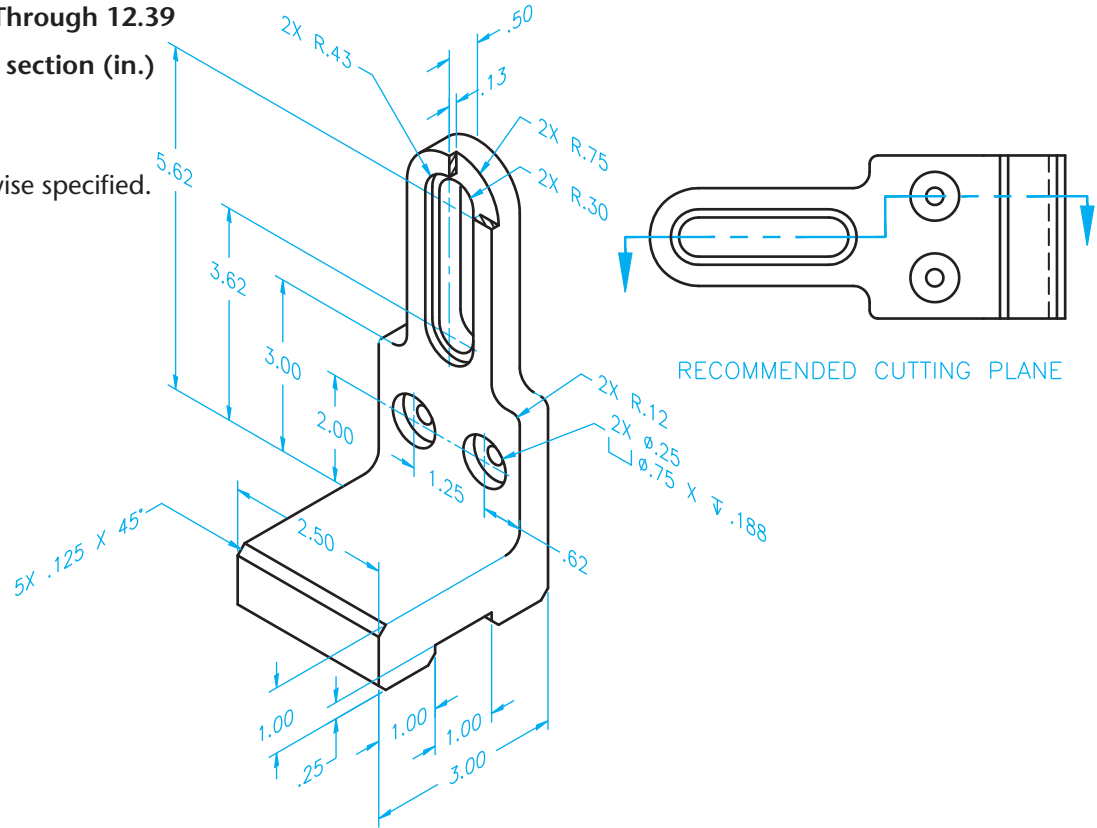
**Part 6: Problems 12.20 Through 12.39**

**PROBLEM 12.20 Offset section (in.)**

Part Name: Slide Bracket

Material: AISI 1020

Fillets: R.25 unless otherwise specified.

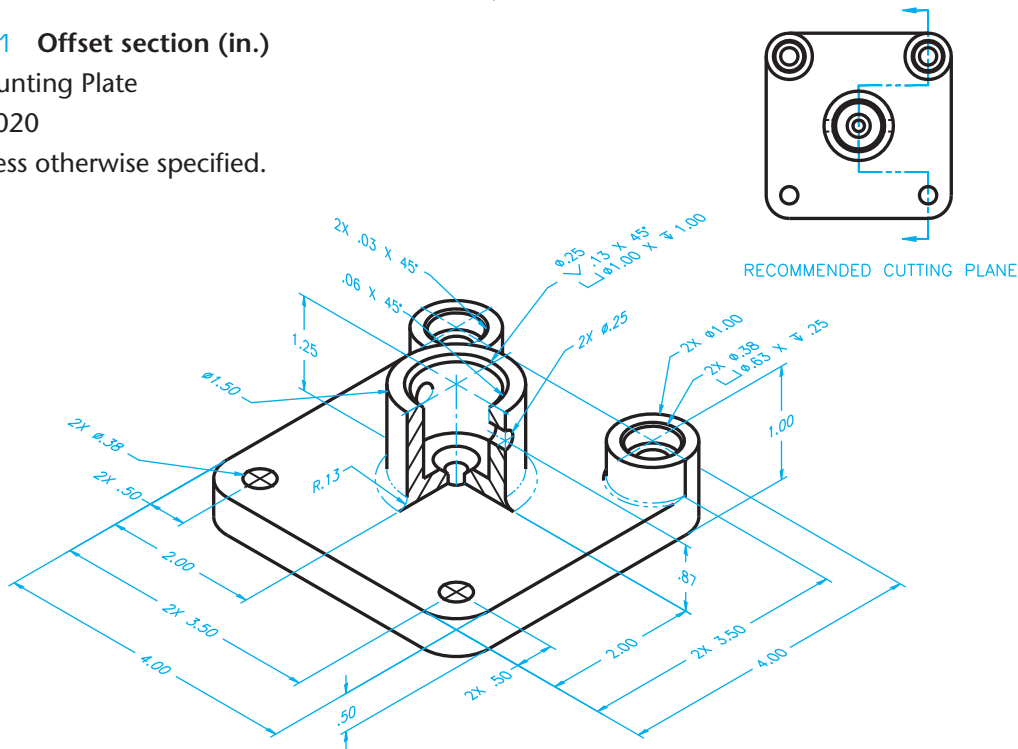


**PROBLEM 12.21 Offset section (in.)**

Part Name: Mounting Plate

Material: AISI 1020

Fillets: R.03 unless otherwise specified.

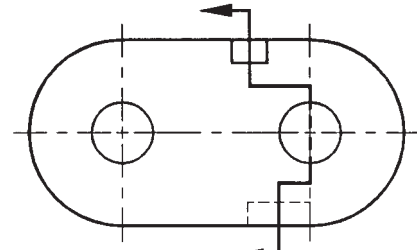
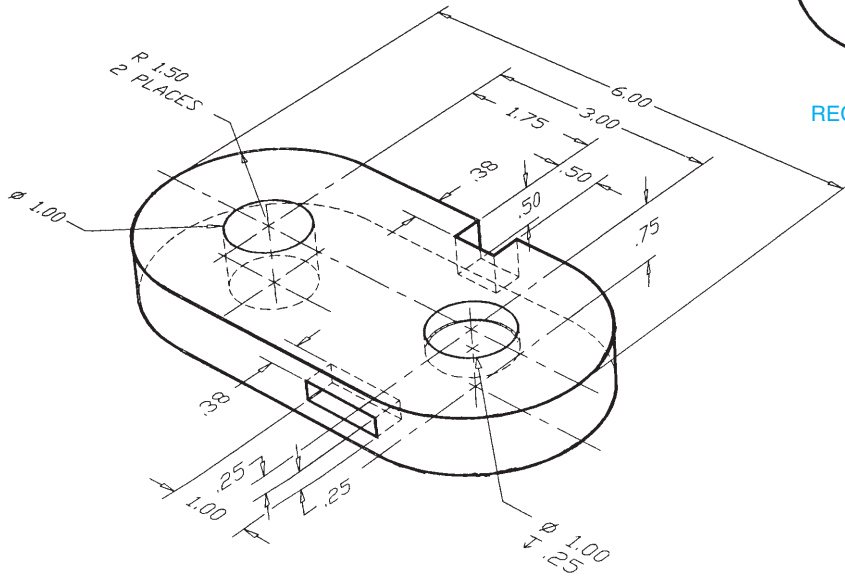


**PROBLEM 12.22** Offset section (in.)

Part Name: Die Casting

Material: SAE 6150

SPECIFIC INSTRUCTIONS: Convert all dimensions to ASME Y14.5 standards as shown and discussed in this textbook.



RECOMMENDED CUTTING PLANE

© Cengage Learning 2012

**PROBLEM 12.23** Offset section (in.)

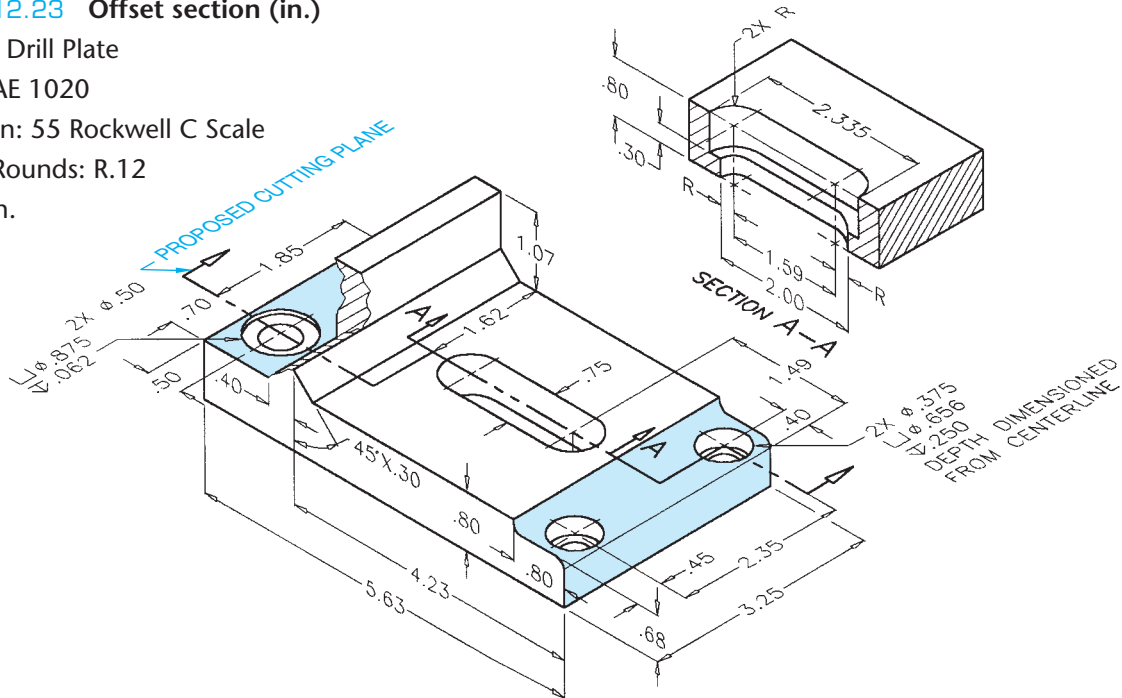
Part Name: Drill Plate

Material: SAE 1020

Case Harden: 55 Rockwell C Scale

Fillets and Rounds: R.12

FAO: 63 μin.



© Cengage Learning 2012

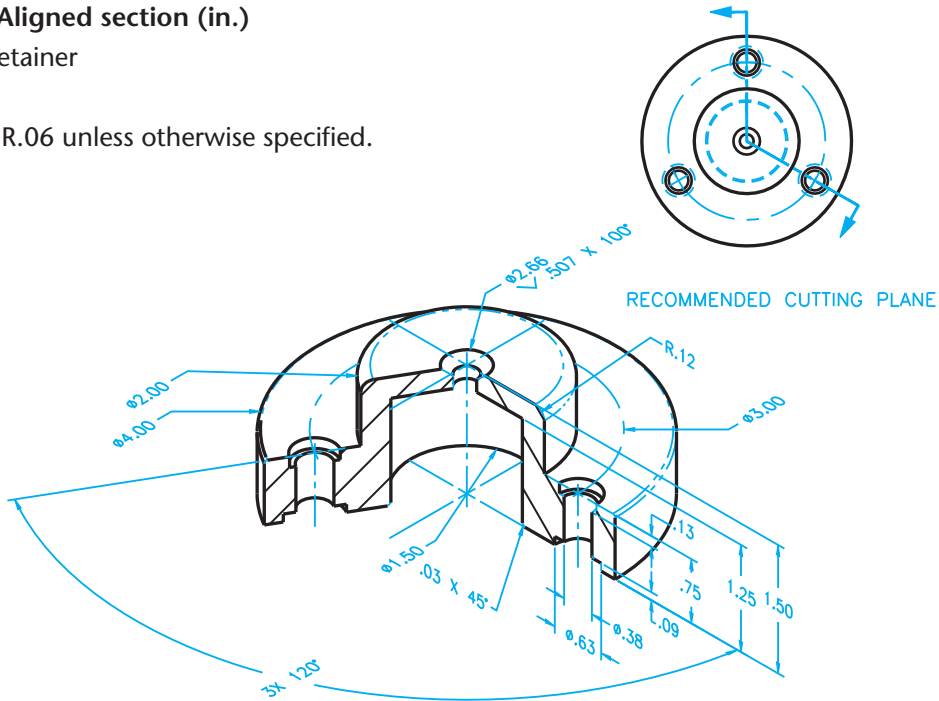


**PROBLEM 12.24** Aligned section (in.)

Part Name: Shaft Retainer

Material: SAE 4340

Fillets and Rounds: R.06 unless otherwise specified.



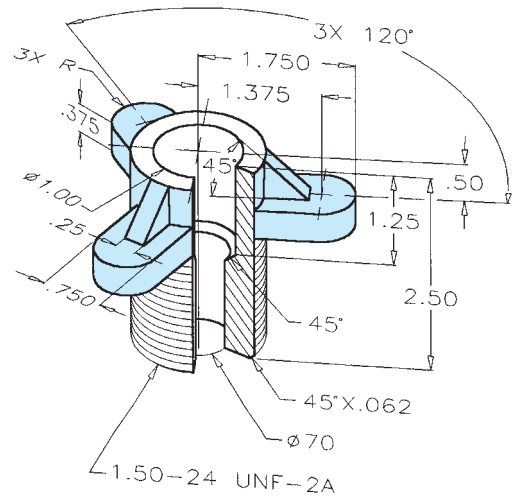
© Cengage Learning 2012

**PROBLEM 12.25** Aligned section (in.)

Part Name: Hub

Material: SAE 3145

Fillets and Rounds: R.125



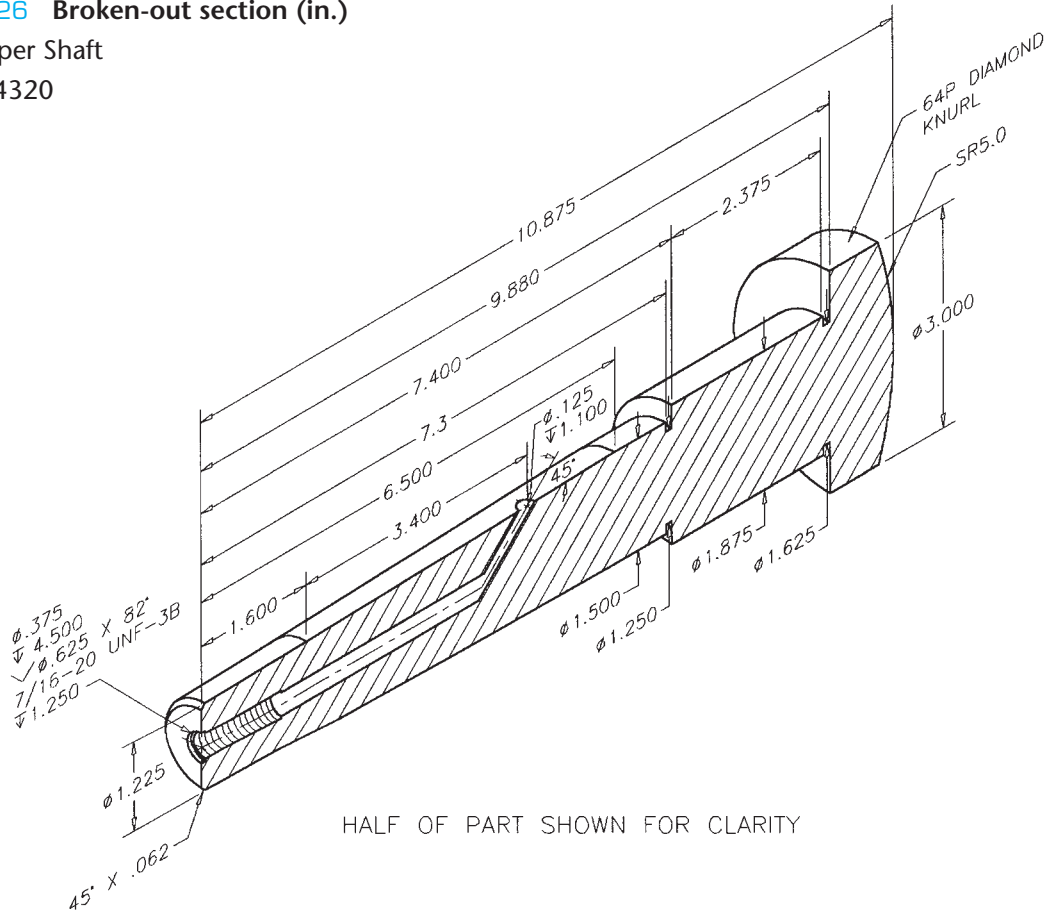
© Cengage Learning 2012

**PROBLEM 12.26 Broken-out section (in.)**

Part Name: Taper Shaft

Material: SAE 4320

FAO: 16 μin.



© Cengage Learning 2012

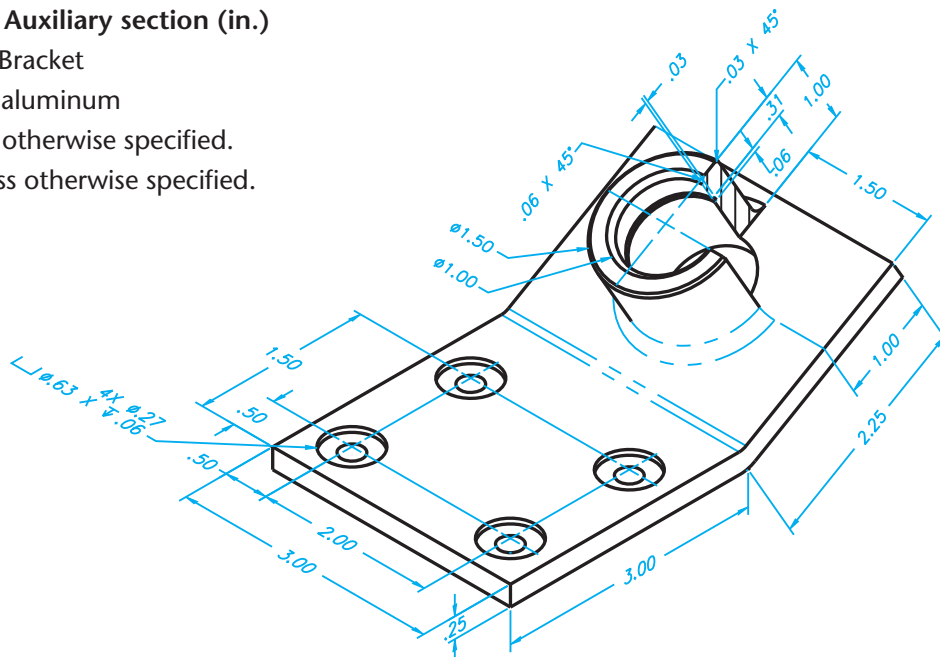
**PROBLEM 12.27 Auxiliary section (in.)**

Part Name: Angle Bracket

Material: 6061-T6 aluminum

Fillets: R.13 unless otherwise specified.

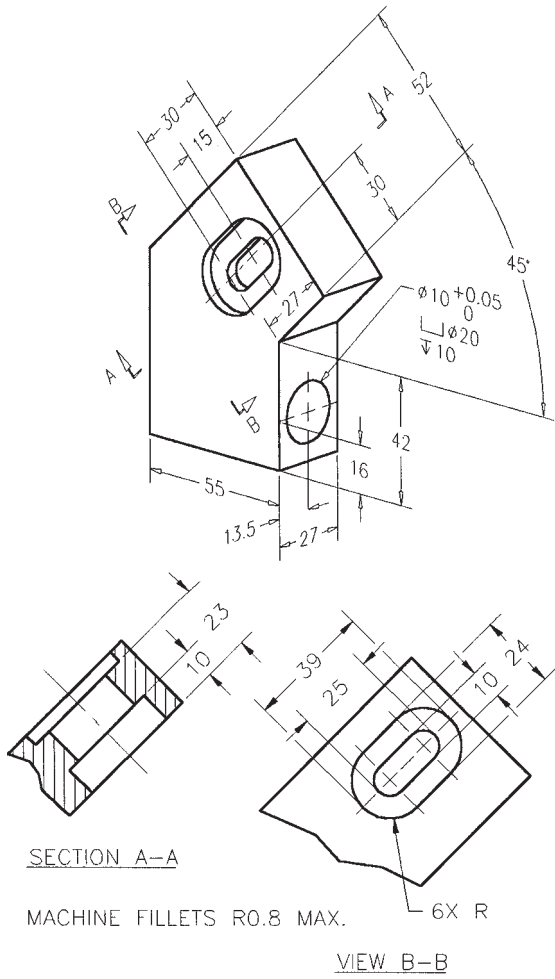
Rounds: R.38 unless otherwise specified.



© Cengage Learning 2012

**PROBLEM 12.28 Auxiliary section (metric)**

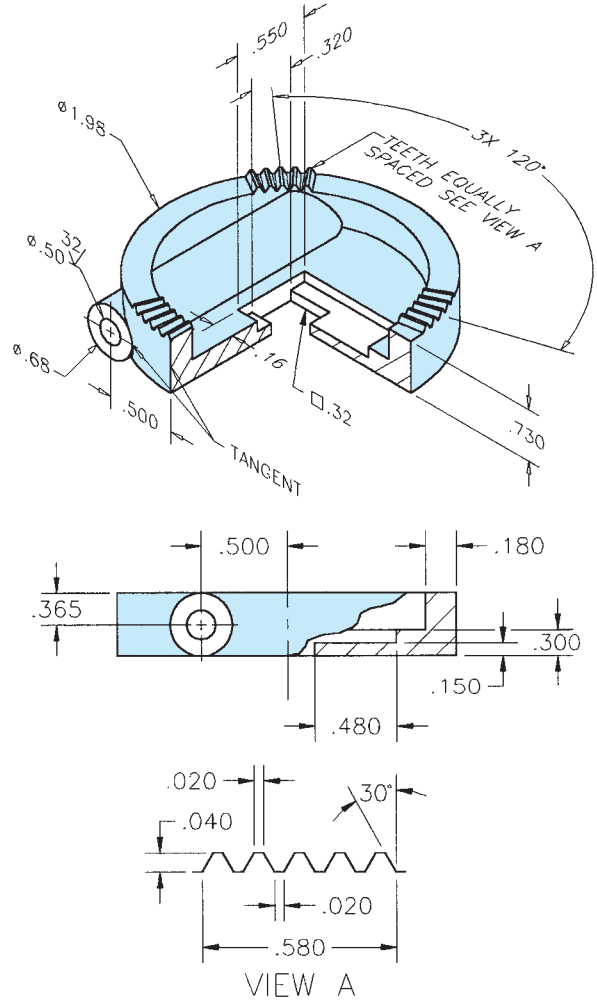
Part Name: Gear Base  
 Material: SAE 2340  
 Finish All Over: 0.8 μm



© Cengage Learning 2012

**PROBLEM 12.29 Broken-out section, view enlargement (in.)**

Part Name: Clamp Cap  
 Material: Cast aluminum  
 Fillets and Rounds: R.06



© Cengage Learning 2012

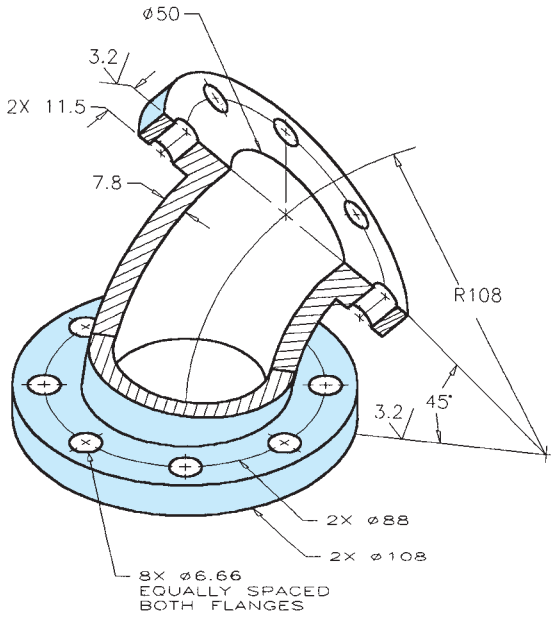
**PROBLEM 12.30 Broken-out section (metric)**

Part Name: 50 mm 45° Elbow

Material: Cast iron

Fillets and Rounds: R4mm

SPECIFIC INSTRUCTIONS: Consider bottom view or auxiliary view for hole pattern dimensions.



© Cengage Learning 2012

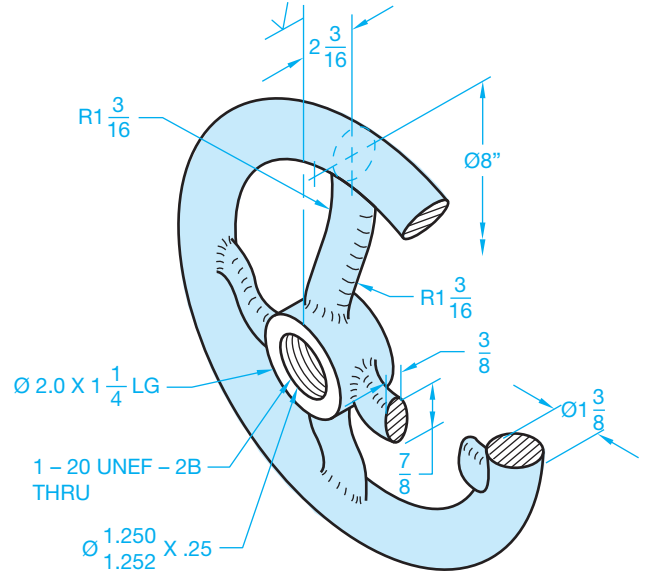
**PROBLEM 12.32 Revolved section (in.)**

Part Name: Offset Handwheel

Material: Bronze

All Fillets and Rounds: R.12

Finishes: 125 μin.



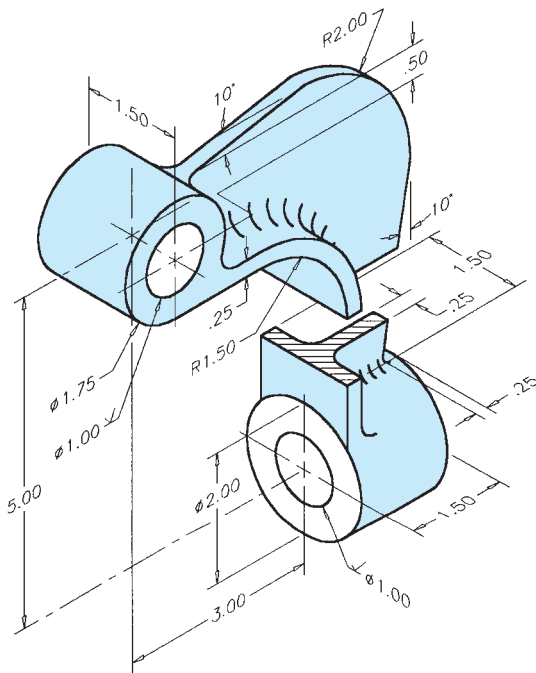
© Cengage Learning 2012

**PROBLEM 12.31 Revolved section (in.)**

Part Name: End Loading Arm

Material: SAE 2310

Fillets and Rounds: R.25



© Cengage Learning 2012

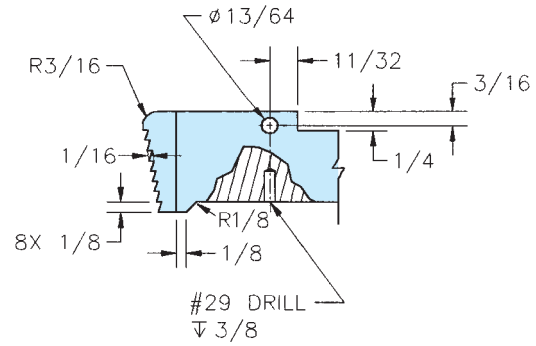
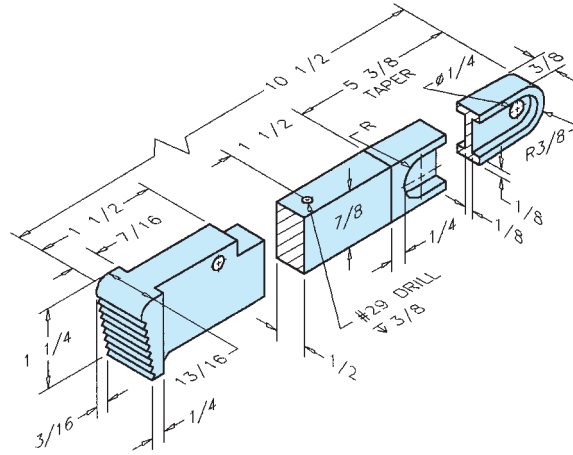
**PROBLEM 12.33** Broken-out, revolved section, view enlargement (in.)

Part Name: Pipe Wrench Handle

Material: SAE 5120

Fillets and Rounds: R.06

SPECIFIC INSTRUCTIONS: Engineering sketch is given in fractional inches. Convert all size dimensions to two-place decimals and location dimensions to three-place decimals for final drawing.

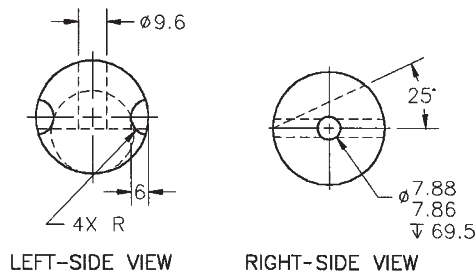


**PROBLEM 12.34** Removed section (metric)

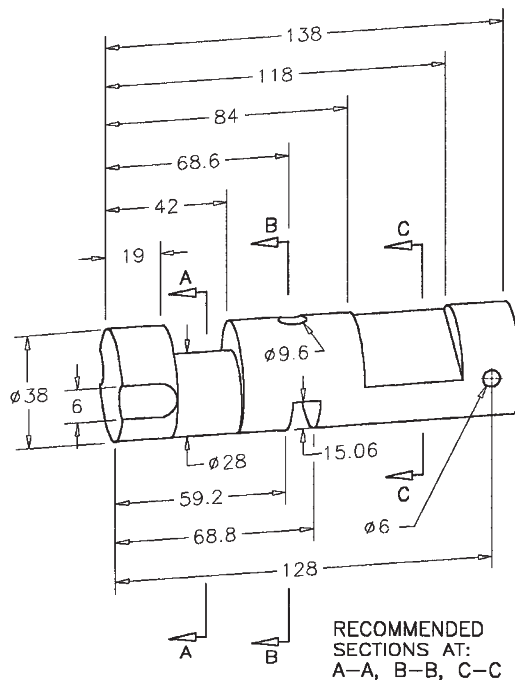
Part Name: Valve Stem

Material: Phosphor bronze

Finish All Over:  $1\ \mu\text{m}$



NOTE: Some hidden lines omitted for clarity.



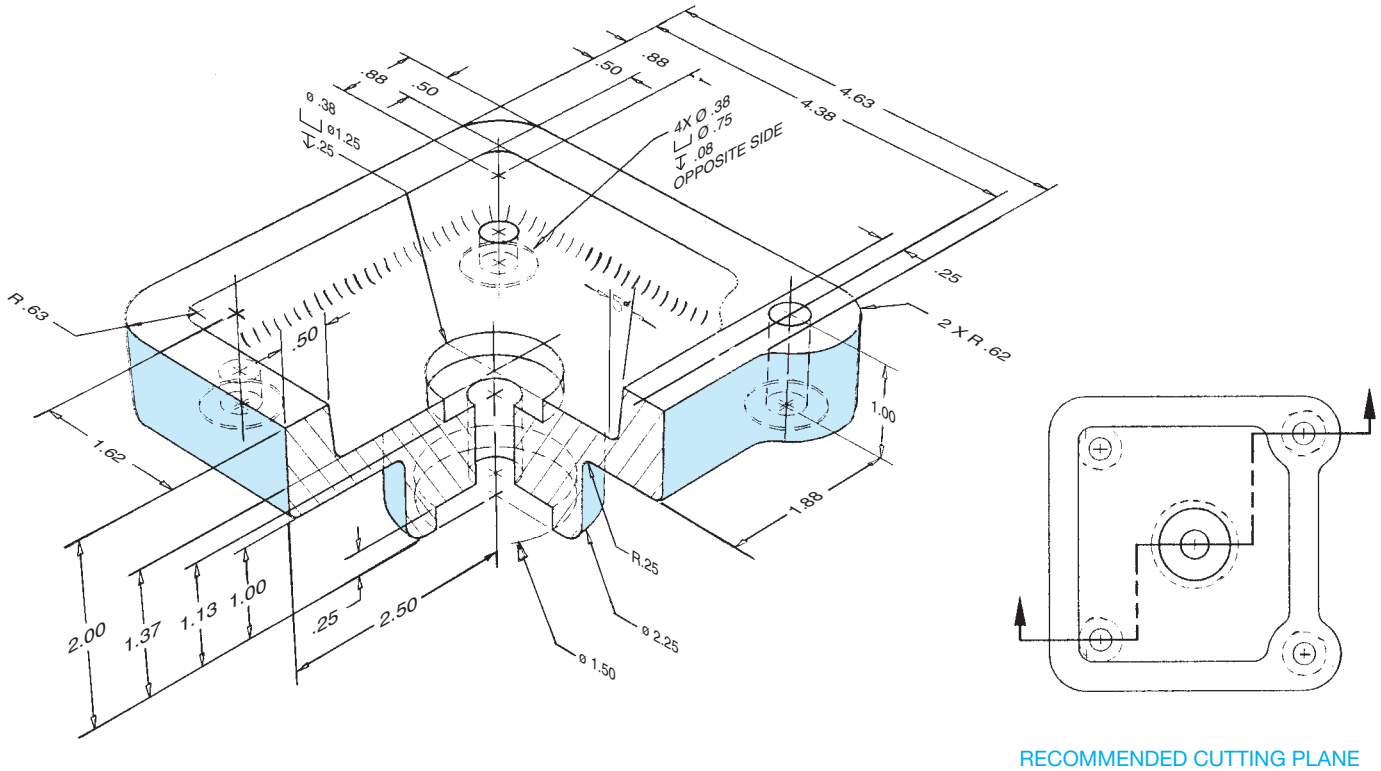
RECOMMENDED SECTIONS AT: A-A, B-B, C-C

**PROBLEM 12.35 Offset section (in.)**

Part Name: Die Plate Casting

Material: SAE 3120

All Fillets and Rounds: R.25 unless otherwise specified.

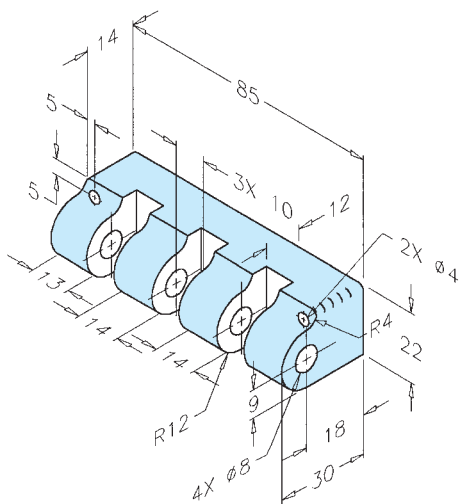


**PROBLEM 12.36 Broken-out section (in.)**

Part Name: Slide Bar Connector

Material: SAE 4120

SPECIFIC INSTRUCTIONS: Convert chain dimensioning to datum dimensioning.

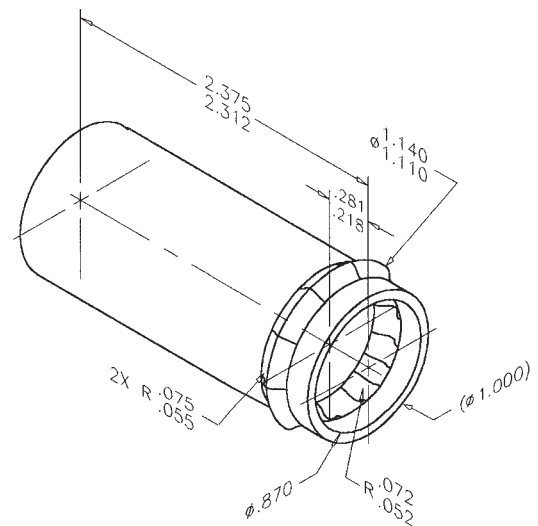


**PROBLEM 12.37 Broken-out section (in.)**

Part Name: Drain Tube

Material: Ø1.00 × .065

Problem based on original art courtesy TEMCO.

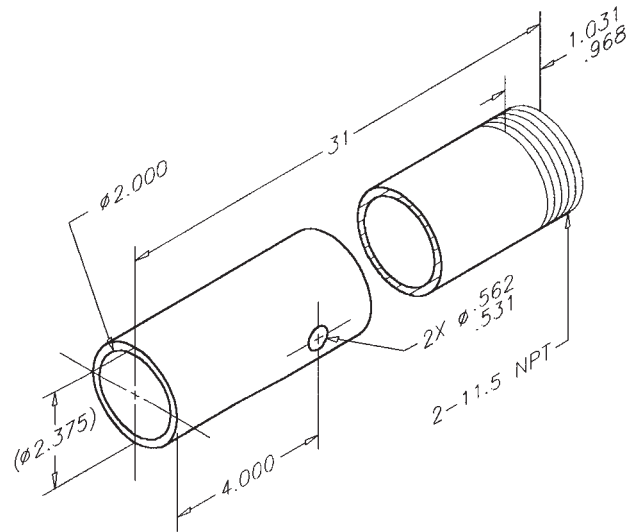


**PROBLEM 12.38 Conventional break (in.)**

Part Name: Leg

Material:  $\varnothing 2.00$  Schedule 40 A120

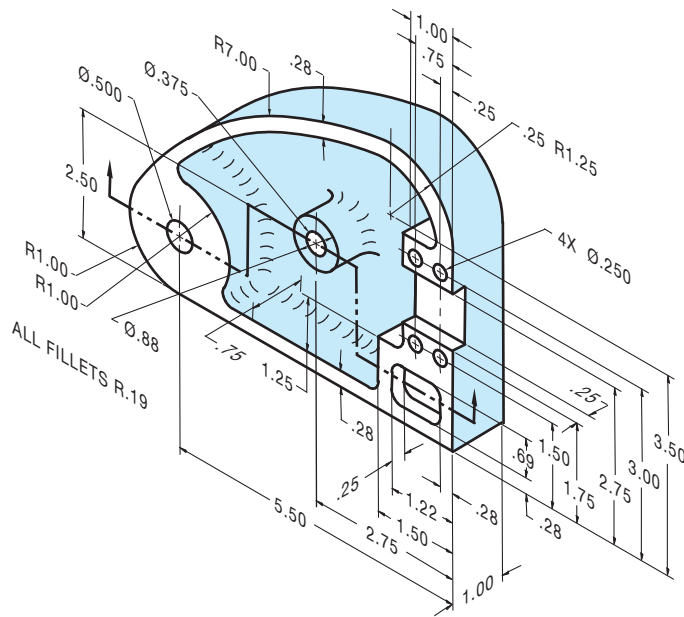
Problem based on original art courtesy TEMCO.



**PROBLEM 12.39 Offset section (in.)**

Part Name: Cover

Material: Cast iron



© Cengage Learning 2012

**Part 7: Problems 12.40 Through 12.51**



To access the Chapter 12 problems, go to the Student CD, select **Chapter Tests and Problems** and **Chapter 12**, and then open the problem of your choice or as assigned

by your instructor. Solve the problems using the instructions provided on the CD, unless otherwise specified by your instructor.

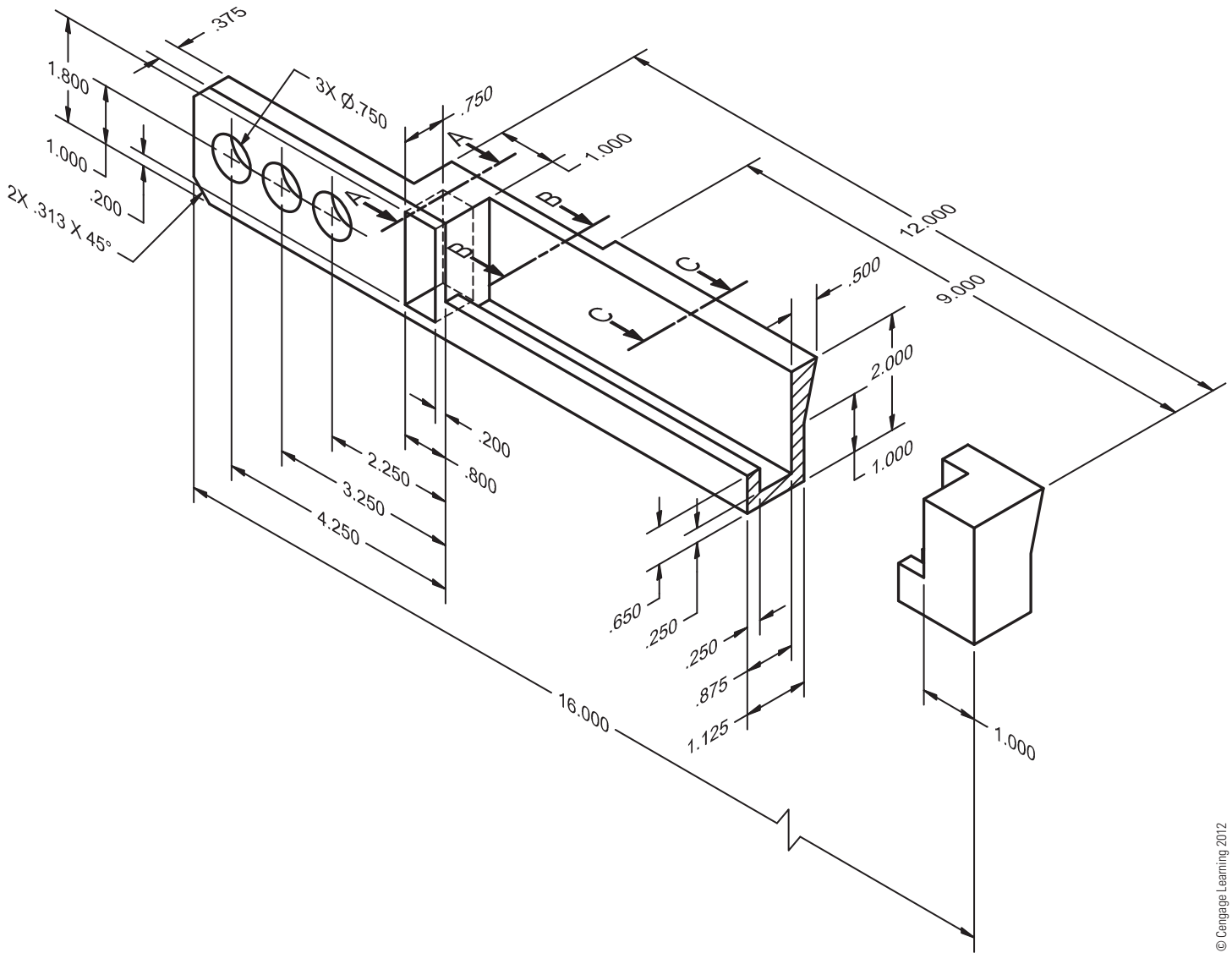
Part 8: Problems 12.52 and 12.53

PROBLEM 12.52 Removed sections (in.)

Part Name: Extension Bar

Material: SAE 4320

SPECIFIC INSTRUCTIONS: This part requires at least three removed sections. A front and top view is recommended, and the recommended section locations are identified. Use conventional removed section cutting planes and place the removed sections in alphabetical order from left to right.





**PROBLEM 12.53** Removed sections arrow method (in.)

Part Name: Extension Bar

Material: SAE 4320

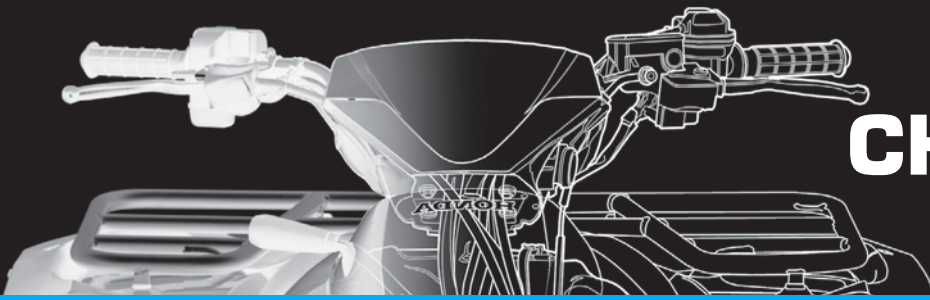
**SPECIFIC INSTRUCTIONS:** Use the same drawing found in Problem 12.52. Use the removed section arrow method for solving this problem.

## Math Problems

### Part 9: Problems 12.54 Through 12.61



To access the Chapter 12 problems, go to the Student CD, select **Chapter Tests and Problems** and **Chapter 12**, and then open the math problem of your choice or as assigned by your instructor. Solve the problems using the instructions provided on the CD, unless otherwise specified by your instructor.



# CHAPTER 13

## Geometric Dimensioning and Tolerancing

### LEARNING OBJECTIVES

After completing this chapter, you will:

- Explain the purpose of geometric tolerancing.
- Use datum feature symbols and datum target symbols on drawings.
- Properly place geometric characteristic, material condition, and material boundary symbols in feature control frames.
- Draw basic dimensions.
- Describe methods for representing datum surfaces, datum target points, areas, lines, datum center planes, and datum axes on drawings.
- Identify the degrees of freedom of a part.
- Use material condition and material boundary symbols on drawings.
- Interpret drawing applications specifying regardless of material size (RFS) and regardless of material boundary (RMB), maximum material condition (MMC) and least material condition (LMC).
- Apply or interpret surface geometric controls and axis geometric controls.
- Determine geometric tolerances for produced sizes at RFS, MMC, and LMC.
- Draw geometric tolerances used to control form tolerances.
- Use geometric tolerances used to control orientation.
- Apply or interpret location tolerances on drawings.
- Explain the differences between conventional tolerancing and positional tolerancing.
- Use and interpret rectangular coordinate and polar coordinate dimensioning on drawings.
- Apply or interpret composite positional tolerances on drawings.
- Interpret geometric tolerances specified for threaded fasteners.
- Apply or interpret projected tolerance zone representations on drawings.
- Calculate and apply virtual condition in designs involving mating parts.
- Draw or interpret concentricity geometric tolerances and positional tolerances specified for coaxial features on drawings.
- Apply or interpret symmetry geometric tolerances and positional tolerances specified for symmetrical features on drawings.
- Use or interpret profile geometric tolerances on drawings.
- Apply or interpret runout geometric tolerances on drawings.
- Interpret form tolerances when independency is specified.

### THE ENGINEERING DESIGN APPLICATION

There have been some problems in manufacturing one of the parts because of the extreme tolerance variations possible. The engineer requests that you revise the drawing in Figure 13.1 and gives you these written instructions:

- Establish datum A with three equally spaced datum target points at each end of the  $\varnothing 28.1\text{--}28.0$  cylinder.
- Establish datum B at the left end surface.
- Make the bottom surfaces of the  $2X \varnothing 40.2\text{--}40.0$  features perpendicular to datum A by 0.06.
- Provide a cylindricity tolerance of 0.3 to the outside of the part.

- Make the  $2X \varnothing 40.2\text{--}40.0$  features concentric to datum A by 0.1.
- Locate the  $6X \varnothing 6 + 0.2$  holes with reference to datum A at MMC and datum B with a position tolerance of 0.05 at MMC.
- Locate  $4X \varnothing 4$  holes with reference to datum A at MMC and datum B with a position tolerance of 0.04 at MMC.

This is an easy job because you did the original drawing on CADD and have a custom geometric tolerancing package. You go back to the workstation and within one hour have the check plot shown in Figure 13.2 ready for evaluation.

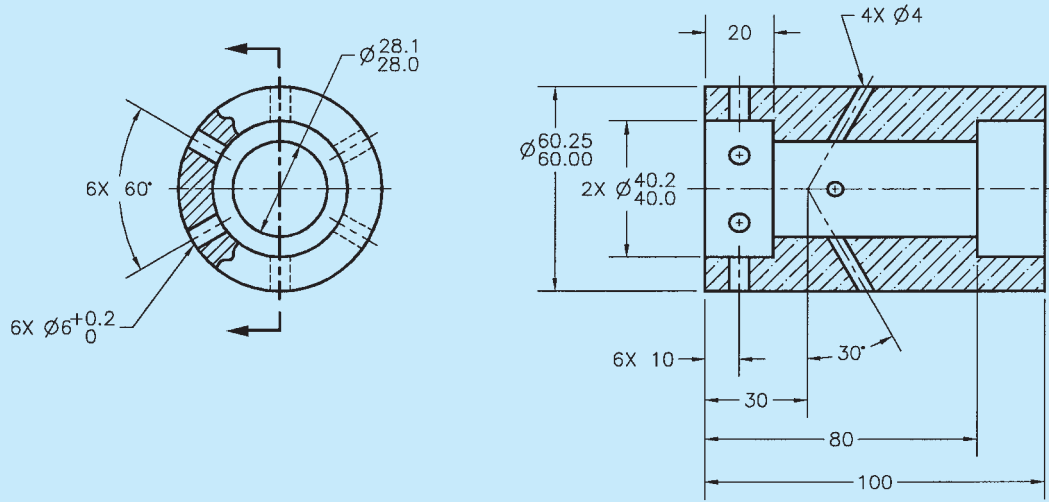


FIGURE 13.1 The original drawing to be revised with geometric tolerancing added from engineering notes.

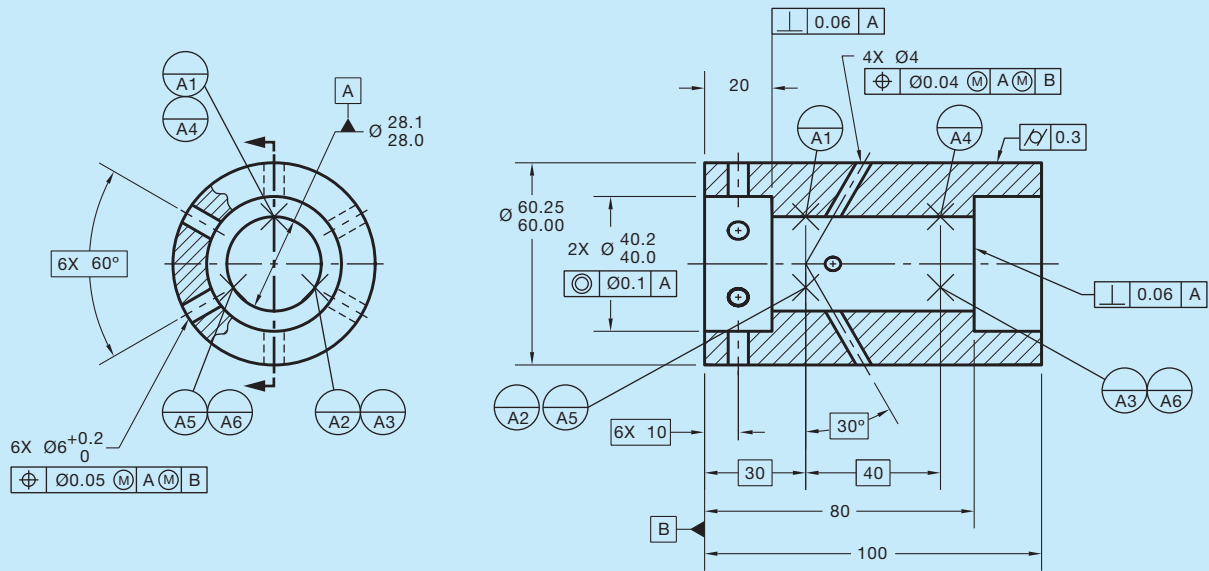


FIGURE 13.2 The revised drawing with geometric tolerancing added.

## INTRODUCTION

When mass-production methods began, interchangeability of parts was important. However, many times parts had to be “hand selected for fitting.” Today, industries have faced the reality that in a technological environment, there is no time to do unnecessary individual fitting of parts. **Geometric tolerancing** helps ensure interchangeability of parts. The function and relationship of a particular feature on a part dictates the use of geometric tolerancing. Geometric tolerancing does not take the place of **conventional tolerancing**. Use of the term *conventional tolerancing* in this text refers to tolerances related to dimensioning practices without regard to geometric tolerancing.

Geometric tolerancing is the dimensioning and tolerancing of individual features of a part in which the permissible variations relate to characteristics of form, profile, orientation, runout, or the relationship between features.

The subject of geometric tolerancing is commonly referred to as *geometric dimensioning and tolerancing (GD&T)*. Geometric tolerancing specifies requirements more precisely than conventional tolerancing, leaving no doubts as to the intended definition. This precision may not be the case when conventional tolerancing is used and notes on the drawing may become ambiguous. When dealing with technology, a drafter needs to know how to represent conventional dimensioning and geometric tolerancing properly. In addition,

a drafter must be able to read dimensioning and geometric tolerancing accurately. Generally, the drafter converts engineering sketches or instructions into formal drawings using proper standards and techniques. After acquiring adequate experience, a design drafter, designer, or engineer begins implementing geometric dimensioning and tolerancing on the research and development of new products or the revision of existing products.

## STANDARDS

**ASME** The primary standard published by the American Society of Mechanical Engineers (ASME) is ASME Y14.5-2009, which is titled *Dimensioning and Tolerancing*. This standard establishes uniform practices for stating and interpreting dimensioning, tolerancing, and related requirements for use on engineering drawings and related documents. The standard ASME Y14.5.1, *Mathematical Definition of Dimensioning and Tolerancing Principles*, provides a mathematical definition of GD&T for the application of ASME Y14.5. ASME Y14.5.2, *Certification of Geometric Dimensioning and Tolerancing Professionals*, establishes certification requirements for a Geometric Dimensioning and Tolerancing Professional (GDTP). The standard ASME Y14.31, *Undimensioned Drawings*, provides the requirements for undimensioned drawings that graphically define features with true geometry views without the use of dimensions. ASME Y14.43, *Dimensioning and Tolerancing Principles for Gages and Fixtures*, provides practices for dimensioning and tolerancing of gages and fixtures used for the verification of maximum material condition. The standard that controls general dimensional tolerances found in the dimensioning and tolerancing block or in general notes is ASME Y14.1, *Decimal Inch Drawing Sheet Size and Format*, and ASME Y14.1M, *Metric Drawing Sheet Size and Format*.

drawings is determined by the policy of your school or company. The general note UNLESS OTHERWISE SPECIFIED, ALL DIMENSIONS ARE IN MILLIMETERS (or INCHES) should be placed on the drawing when all dimensions are in either millimeters or inches. When some inch dimensions are placed on a metric drawing, the abbreviation IN should follow the inch dimensions. The abbreviation mm should follow any millimeter dimensions on a predominately inch-dimensioned drawing. Refer to Chapter 10, *Dimensioning and Tolerancing*, for specific rules related to the use of metric and inch dimension values.

## GD&T SYMBOLS

This section helps you identify symbols and learn related terms. Your main objective is to recognize the various types of symbols by their name, shape, and size. Only a few terms are defined at this time. Other terms are clearly defined later in this chapter as you learn about geometric tolerancing. Symbol sizes are based on drawing lettering height. You will see the note **h = lettering height** when symbol examples are provided. The h equals the predominant lettering height on the drawing. For example, the lettering height on most engineering drawings is .12 in. (3 mm).

Dimensioning and geometric tolerancing symbols are divided into five basic types:

- Dimensioning symbols, which were introduced and described in Chapter 10, *Dimensioning and Tolerancing*.
- Datum feature and datum target symbols.
- Geometric characteristic symbols.
- Material condition symbols.
- Feature control frame.

Geometric tolerancing symbols are drawn using thin lines that are the same thickness as extension and dimension lines .01 in. (0.3 mm). Each type of geometric tolerancing symbol is shown and detailed where it applies to the following content.

## DATUMS

**Datums** are considered theoretically perfect planes, surfaces, points, lines, or axes. Datums are placed on drawings as requirements for referencing features of an object, as in baseline dimensioning (discussed in Chapter 10). Datums are used by the machinist, toolmaker, or quality control inspector to ensure that the part is in agreement with the drawing. Datums are planes, points, lines, or axes from where measurements are made. A **datum feature** is an actual feature on a part, such as a surface, that is used to establish a datum. A datum is the true geometric counterpart of a datum feature. Datums are placed on drawings as requirements for referencing features of an object. Location and size dimensions are established from the datum. Examples of datums in manufacturing are machine tables, surface plates, gauge surfaces, surface tables, and specially designed rotation devices. These are referred to as **datum feature simulators**, and

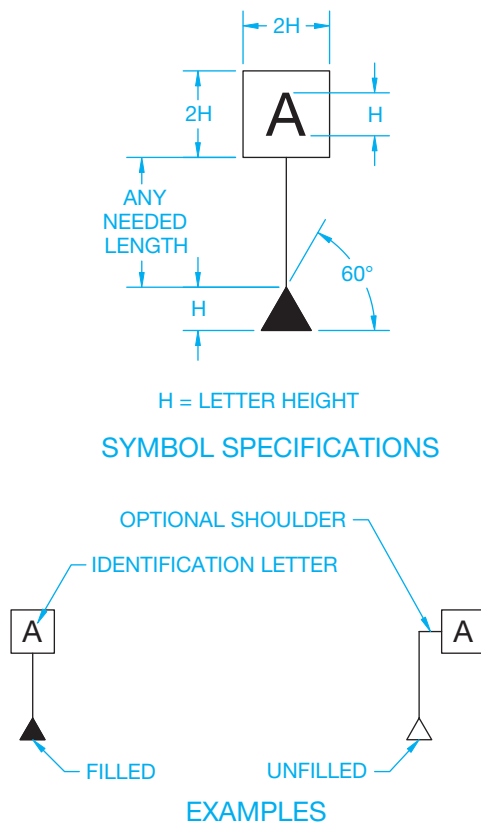


**NOTE:** The examples in this textbook are based on the ASME Y14.5-2009 standard, *Dimensioning and Tolerancing*, published by the American Society of Mechanical Engineers. All drawings based on the ASME Y14.5-2009 standard should have a general note that states DIMENSIONING AND TOLERANCING PER ASME Y14.5-2009. You have been placing this general note on many drawing problems so far throughout this textbook, and you will continue on future drawing problems where instructed. Most dimensions in this text are in metric units based on the International System of Units (SI). Problems are provided with metric and inch dimensions. The common SI unit of measure used on engineering drawings is the millimeter. The common US unit used on engineering drawings is the inch. The actual units used on your engineering

they are used to contact the datum features and establish what are known as the *simulated datums*. The datum feature simulator is an imperfect physical feature of adequate accuracy in which the errors are considered irrelevant. A datum feature simulator can be tooling, such as a surface plate or angle block, or a set of points established on the datum feature using a coordinate measuring machine. There are many concepts to keep in mind when datums are established, including the function of the part or feature, manufacturing processes, methods of inspection, the shape of the part, relationship to other features, assembly considerations, and design requirements. Datum features should be selected to match on mating parts, be easily accessible, and be of adequate size to permit control of the datum requirements.

## Datum Feature Symbol

Datum feature symbols are commonly drawn using thin lines with the symbol size related to the drawing lettering height. The triangular base on the datum feature symbol can be filled or unfilled, depending on the company or school preference. The filled base helps easily locate these symbols on the drawing. Each datum feature on a part requiring identification must be assigned a different datum identification letter. Uppercase letters of the alphabet—except the letters I, O, and Q—are used for datum feature symbol letters. These letters are not used because they can be mistaken for numbers. Figure 13.3 shows the specifications for drawing a datum feature symbol.



**FIGURE 13.3** Drawing specifications for datum feature symbols.

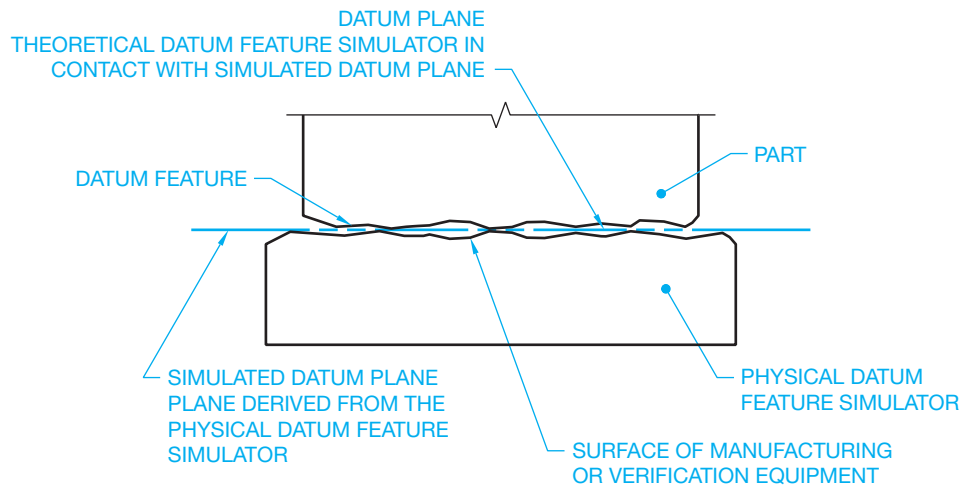
The datum feature symbol is placed on the drawing to identify the features of the object that are specified as datums and referred to as *datum features*. The datum feature symbol identifies physical features and shall not be applied to centerlines, center planes, or axes. This symbol is placed in the following locations on a drawing:

- On the outline of a feature surface in the view where the surface appears as an edge.
- On a leader line directed to the surface. The leader line can be shown as a dashed line if the datum feature is not on the visible surface.
- On an extension line projecting from the edge view of a surface, clearly separated from the dimension line.
- On a chain line next to a partial datum surface.
- On the dimension line or an extension of the dimension line of a feature of size when the datum is an axis or center plane.
- On the outline of a cylindrical feature or an extension line of the feature outline, separated from the size dimension, when the datum is an axis.
- Above or below and attached to a feature control frame.

## Datum Feature

The datum feature is the actual feature of the part that is used to establish the datum. When the datum feature is a surface, it is the actual surface of the object that is identified as the datum. Look at the magnified view of a datum feature placed on the simulated datum in Figure 13.4 and study the following related terms.

- **Actual mating envelope:** The smallest size that can be contracted about an external feature or the largest size that can be expanded within an internal feature.
- **Datum feature:** The actual feature of the part, such as a surface.
- **Datum feature simulator:** The opposite shape of the datum feature. There are two types of datum feature simulators: (1) The theoretical datum feature simulator is a perfect boundary used to establish a datum from a specified datum feature; (2) the physical datum feature simulator is the physical boundary used to establish a simulated datum from a specified datum feature. The manufacturing inspection equipment associated with the datum feature or features is used as the physical object to establish the simulated datum or datums. Physical datum feature simulators represent the theoretical datum feature simulators during manufacturing and inspection. A datum feature simulator can be one of the following: maximum material boundary (MMB), least material boundary (LMB), the actual mating envelope, a tangent plane, or a mathematically defined contour.



**FIGURE 13.4** Datum plane, datum feature, and the simulated datum plane. Datums are to be treated as if they are perfect even though they may not be perfect.

© Cengage Learning 2012

A datum feature simulator has the following requirements:

- Perfect form.
- **Basic** orientation to each other for all the datum references in the feature control frame.
- Basic location relative to other datum feature simulators for all the datum references in the feature control frame, unless a translation modifier or movable datum target symbol is specified.
- Movable location when a translation modifier or movable datum target symbol is specified.

The term *basic* refers to a **basic dimension**. A basic dimension is a theoretically exact dimension. Basic dimensions are used to establish true position from datums and between interrelated features and to define true profile.

In actual practice, measurements cannot be made from theoretical datum features or datum feature simulators. This is why manufacturing inspection equipment is of the highest quality for making measurements and verifying dimensions even though they are not perfect.

**Datum plane:** The theoretically exact plane established by the simulated datum of the datum feature.

**Simulated datum:** A point, axis, line, or plane consistent with or resulting from processing or inspection equipment, such as a surface plate, inspection table, gage surface, or a mandrel. The simulated datum plane in Figure 13.4 is the plane derived from the physical datum feature simulator and coincides with the datum plane when the datum plane is in contact with the simulated datum plane.

**Tangent plane:** A plane that contacts the high points of the specified feature surface.

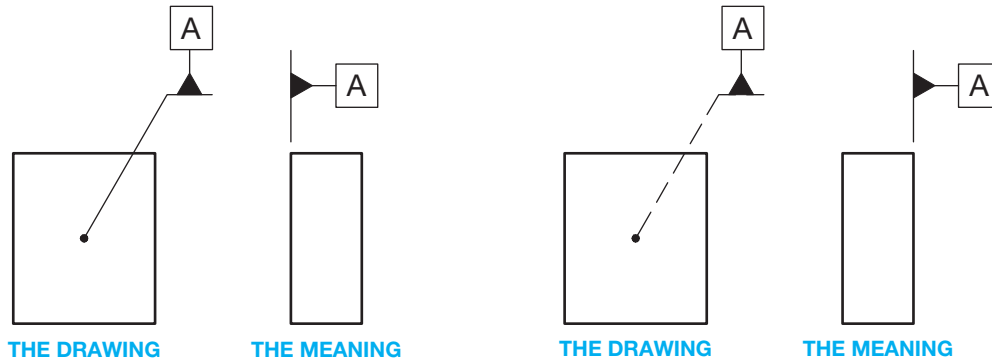
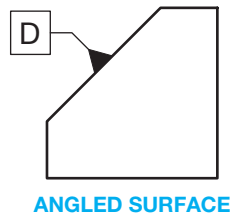
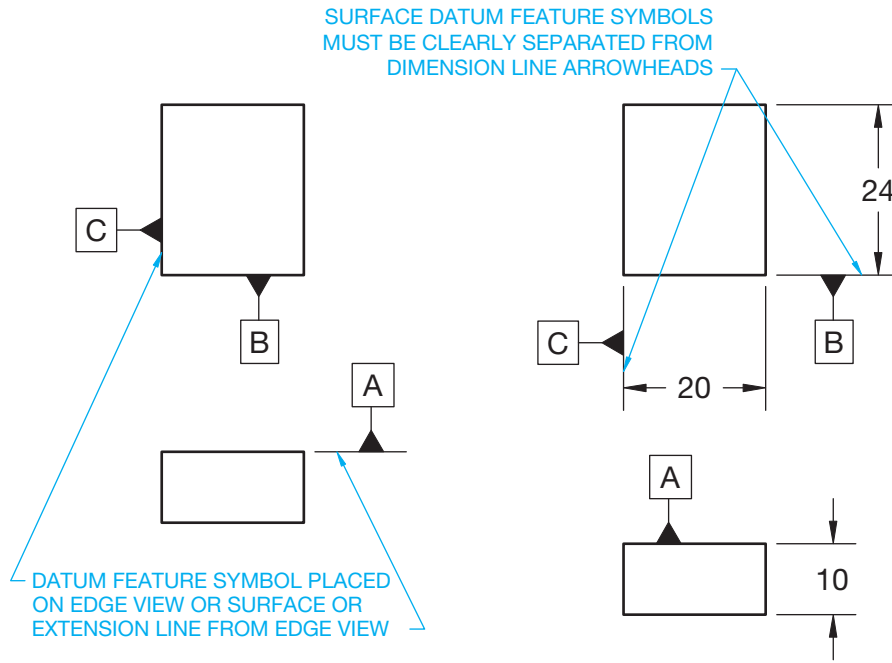
When a surface is used to establish a datum plane on a part, the datum feature symbol is placed on the edge view of the surface or on an extension line in the view where the surface appears as a line. Refer to Figure 13.5. A leader line can also be used to connect the datum feature symbol to the view in some applications.

## Geometric Control of Datum Surface

The datum surface can be controlled by a geometric tolerance such as flatness, straightness, circularity, cylindricity, or parallelism. Measurements taken from a datum plane do not take into account any variations of the datum surface from the datum plane. Any geometric tolerance applied to a datum should only be specified if the design requires the control. Figure 13.6 shows the feature control frame and datum feature symbol together. Figure 13.7 is a magnified representation that shows the meaning of the drawing in Figure 13.6. The geometric tolerance of 0.1 is specified in the feature control frame in Figure 13.6. The maximum size that the part can be produced is the upper limit of the dimensional tolerance, or MMC. The MMC is  $12.5 + 0.3 = 12.8$ . The minimum size that the part can be produced is the lower limit of the dimensional tolerance, or LMC. The LMC is  $12.5 - 0.3 = 12.2$ .

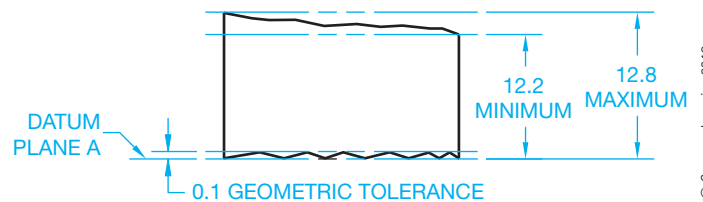
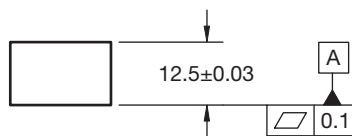
## Datum Reference Frame

Datum features are selected based on their importance to the design of the part. Generally, three datum features are selected that are perpendicular to each other. The three datums are called the **datum reference frame (DRF)**. The datums that make up the datum reference frame are referred to as the *primary datum*,



© Cengage Learning 2012

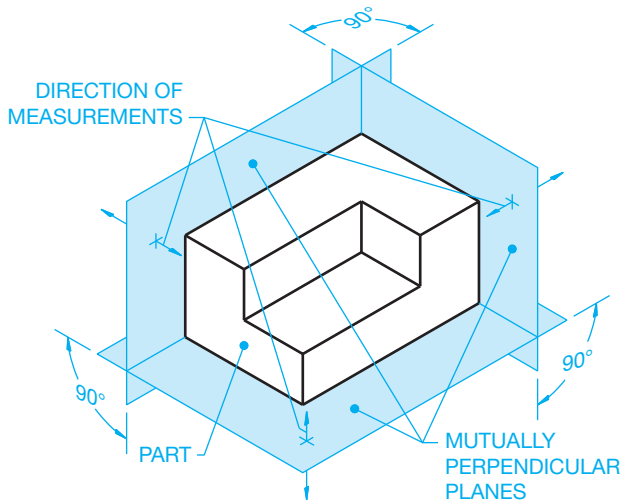
**FIGURE 13.5** Methods for placing datum feature symbols on surface datums. The datum feature symbol is placed on the edge view or on an extension line in the view where the surface appears as a line. The datum feature symbol can also be placed on a leader line directed to the surface. The leader line can be shown as a dashed line if the datum feature is not on the visible surface.



© Cengage Learning 2012

**FIGURE 13.6** A feature control frame and datum feature symbol.  
© Cengage Learning 2012

**FIGURE 13.7** The meaning of the drawing in Figure 13.6.



© Cengage Learning 2012

FIGURE 13.8 The datum reference frame.

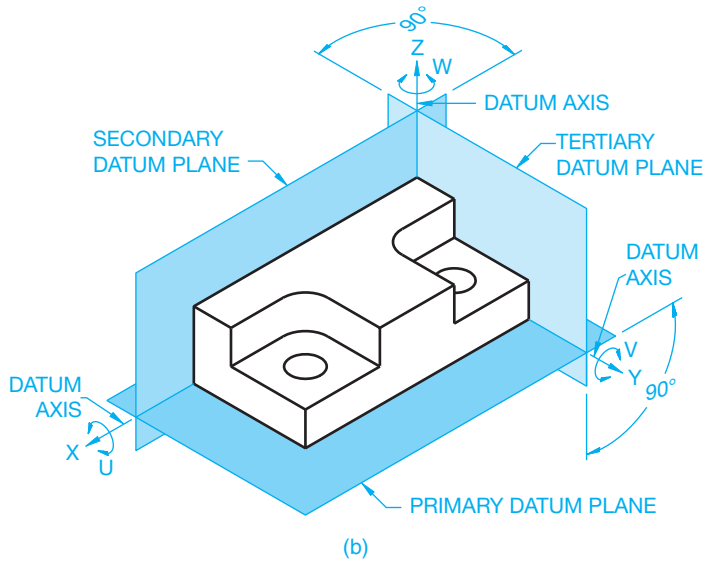
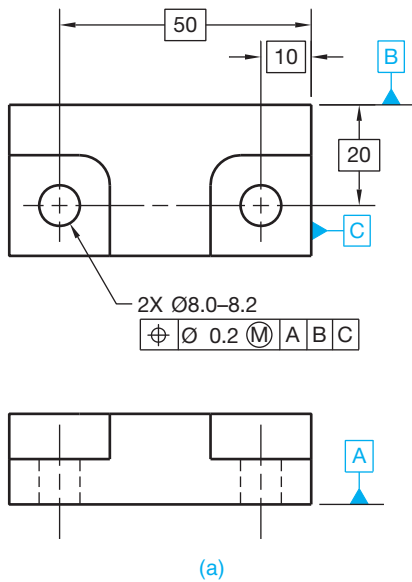
secondary datum, and tertiary datum. The primary datum is the most important, followed by the other two in order of importance. Figure 13.8 shows how the direction of measurement is projected to various features on the object from the three common perpendicular planes of the datum reference frame. The primary datum must be inspected first, the secondary datum inspected second, and the tertiary datum inspected third, regardless of the letters. For example, the letters in the feature

control frame might be C, B, A, where C is the primary datum, B is the secondary datum, and A is the tertiary datum. The datum feature symbols on the drawing relate to the datum features on the part. See datums A, B, and C in Figure 13.9a. The datum reference order is A, B, C in the feature control frame. The datum reference in the feature control frame specifies that datum A is primary, datum B is secondary, and datum C is tertiary.

The geometric tolerance that controls a feature or features relative to datums must include one or more datum references. The surface of the part labeled as the primary datum is placed on the surface of an inspection table or manufacturing inspection equipment. Measurements are made from the primary datum inspection table surface to features that are dimensioned from the primary datum. The part is then positioned against the primary and secondary datums, dimensions are verified from the secondary datum inspection table surface to features dimensioned from the secondary datum. Finally, the tertiary datum is established to confine the part totally in the datum reference frame as shown in Figure 13.9b. With the part totally confined in the datum reference frame, all measurements made from the simulated datum planes to related features on the part are reliable and have the same origin every time.

### Degrees of Freedom

All parts have six **degrees of freedom**. There are three **translational** degrees of freedom and three **rotational** degrees of freedom. The term *degrees of freedom* means the number of



© Cengage Learning 2012

FIGURE 13.9 (a) The datum feature symbols on the drawing relate to the datum features on the part. (b) The same part placed in the datum reference frame. All parts have six degrees of freedom. The three translational degrees of freedom for this part are labeled X, Y, and Z. The three rotational degrees of freedom for this part are labeled U, V, and W.



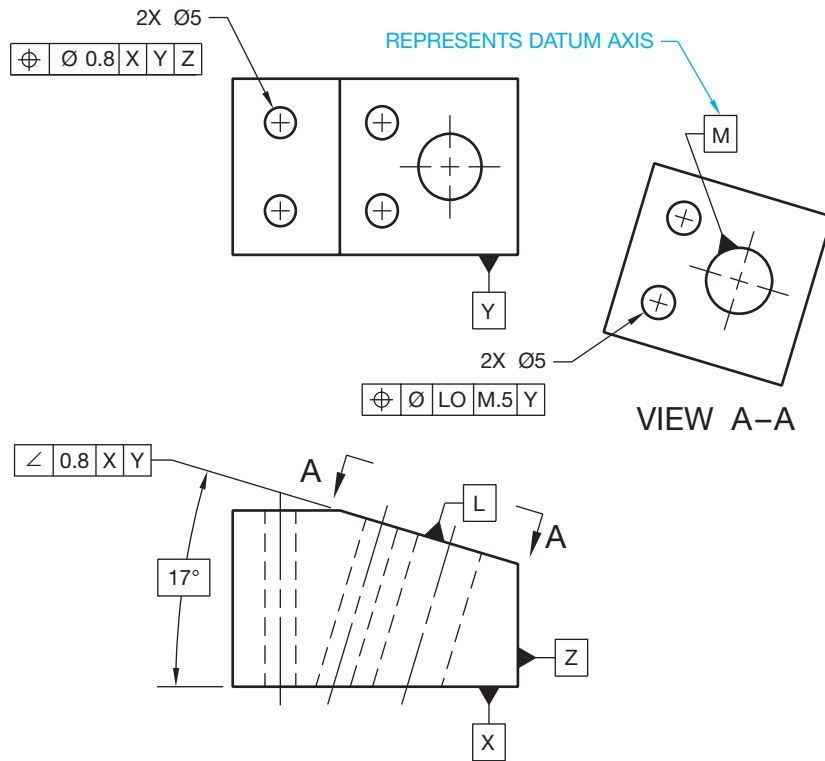


FIGURE 13.10 Multiple datum reference frames.

© Cengage Learning 2012

coordinates it takes to control the position of a part exclusively. The term *translational* refers to uniform movement without rotation, and the term *rotational* refers to movement around an axis. Considering the datum reference frame in Figure 13.9b, the part can move without rotation in each of the three directions from the mutually perpendicular planes. This is called the *three degrees of translation*. The part can also rotate about each of the axes, which is referred to as the *three degrees of rotation*. Refer again to Figure 13.9b and notice that the three translational degrees of freedom are labeled X, Y, and Z. The three rotational degrees of freedom are labeled U, V, and W. The following demonstrates the degrees of freedom related to the primary, secondary, and tertiary datums:

The primary datum plane constrains three degrees of freedom: One translational in Z. One rotational in U. One rotational in V.

All parts have six degrees of freedom. The three translational degrees of freedom for this part are labeled X, Y, and Z. The three rotational degrees of freedom for this part are labeled U, V, and W.

The secondary datum plane constrains two degrees of freedom: One translational in Y. One rotational in W.

The tertiary datum plane constrains one degree of freedom: One translational in X.

## Multiple Datum Reference Frames

Depending on the functional requirements of a part, more than one datum reference frame can be established. In Figure 13.10, datums X, Y, and Z are one datum reference frame, and datums L and M establish a second reference frame. The relationship between the two datum reference frames is controlled by the angularity tolerance on datum feature L. Datum M is the axis of the large hole to which the datum feature symbol is connected. Datum axes are discussed later in this chapter. For parts with inclined datum features, as in Figure 13.10, the datum feature simulator plane is oriented at the basic angle of the datum feature. The related datum reference frame plane passes through the vertex of the basic angle and is mutually perpendicular to the other datum planes.

## Datum Features Specified Individually

When multiple datum reference frames exist and features need to be positioned to different datums individually, then a note can be placed next to the datum feature symbols identifying how many datum features are to be considered separately. For example, if there are two separate datum features that are

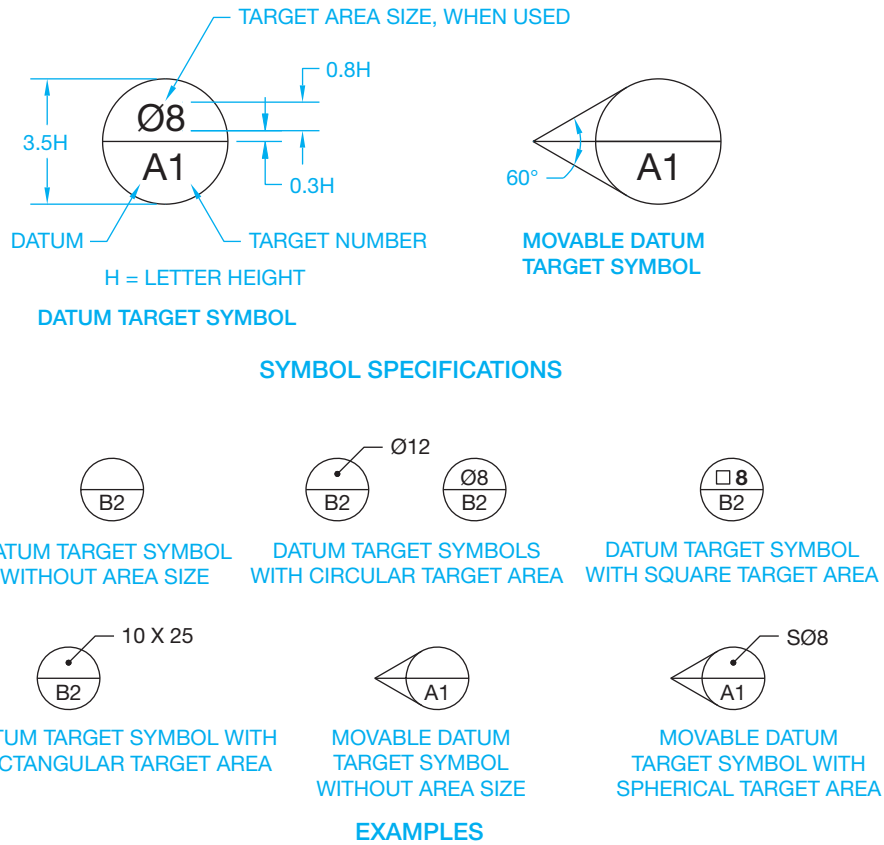


FIGURE 13.11 Drawing specifications for datum target symbols and example applications.

© Cengage Learning 2012

identified with the same datum identification letter, but they need to be considered individually, the note 2X INDIVIDUALLY is placed next to the datum feature symbols.

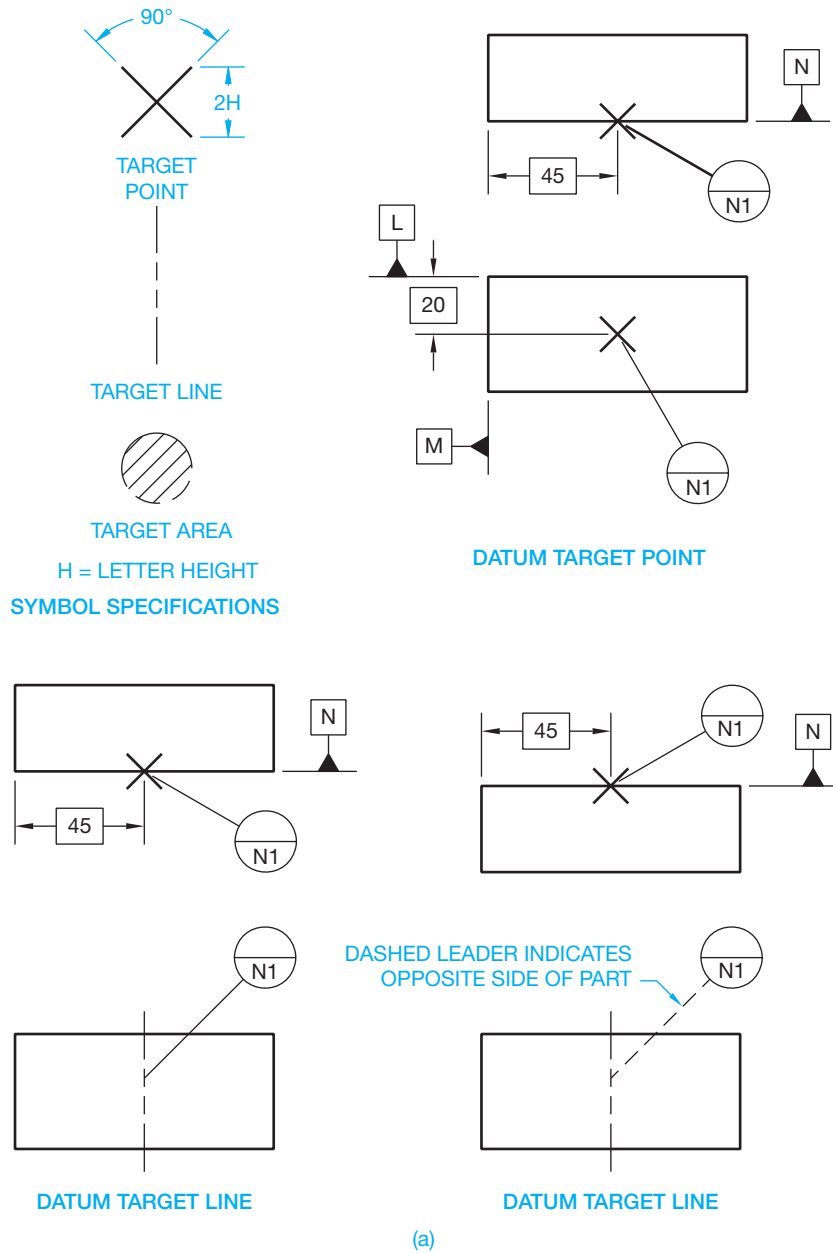
### Using Datum Target Symbols

In many situations, it is not possible to establish an entire surface, or entire surfaces, as datums. When this happens, datum targets can be used to establish datum planes. Datum targets are designated points, lines, or surface areas that are used to establish the datum reference frame. This procedure is especially useful on parts with surface or contour irregularities, such as some sheet metal, sand cast, or forged parts that are subject to bowing or warpage. However, datum targets can be used on most parts. Use datum targets to minimize the variation in the way features are measured. This method can also be applied to weldments, where heat can cause warpage.

The datum target symbol is drawn as a circle using thin lines. The circle is divided into two parts with a horizontal line. The bottom half provides the datum reference letter and the specific datum target number on that datum. The top half is left blank if a datum target point or line is identified. When identifying

a datum target area, the top half contains the shape and size of the area. The dimension for the datum target area can be placed outside the datum target symbol with a leader and a dot pointing to the upper half if the dimension is too big to fit inside (see Figure 13.11). When the datum target area is circular, a diameter symbol precedes the size value. When the datum target area is square, a square symbol precedes the size value. The datum target area can also be rectangular in shape, which is dimensioned with a length and width value, such as 10 × 25. The rectangular dimension is placed outside the datum target symbol, and a leader points to the top half of the datum target symbol. A spherical datum target area can be used by placing the spherical diameter symbol in front of the size value. The spherical diameter is generally placed outside the datum target symbol, and a leader points to the top half of the datum target symbol. A movable datum target symbol is used to indicate that the datum target is not fixed at its basic location and is free to translate.

The datum target symbol is connected with a leader to the datum target point, line, or area on the drawing. The leader line generally has no shoulder or arrowhead. Example applications of datum target points and datum target lines are shown



**FIGURE 13.12** (a) The datum target point and datum target line and examples of their use. (b) Applications of datum target areas.

in Figure 13.12a. Example applications of datum target areas are shown in Figure 13.12b. Additional uses are provided where they relate to specific applications.

### Establishing Datum Target Points

Datum planes are established by the datum points as follows:  
 The primary datum plane must be established by at least three points on the primary datum surface. These points are used to provide stability on the primary plane, similar to a three-legged stool.

The secondary datum plane must be located by at least two points on the related secondary datum surface. Two points provide the required stability for the secondary plane.

The tertiary datum plane must be located by at least one point on the related tertiary datum surface. One point of contact at the tertiary datum plane is all that is required to complete the datum reference frame and provides complete stability of the part in the datum reference frame.

Baseline or chain dimensioning can be used to locate datum target points. The location dimensions must originate from datums. Datum target points are established on the drawing

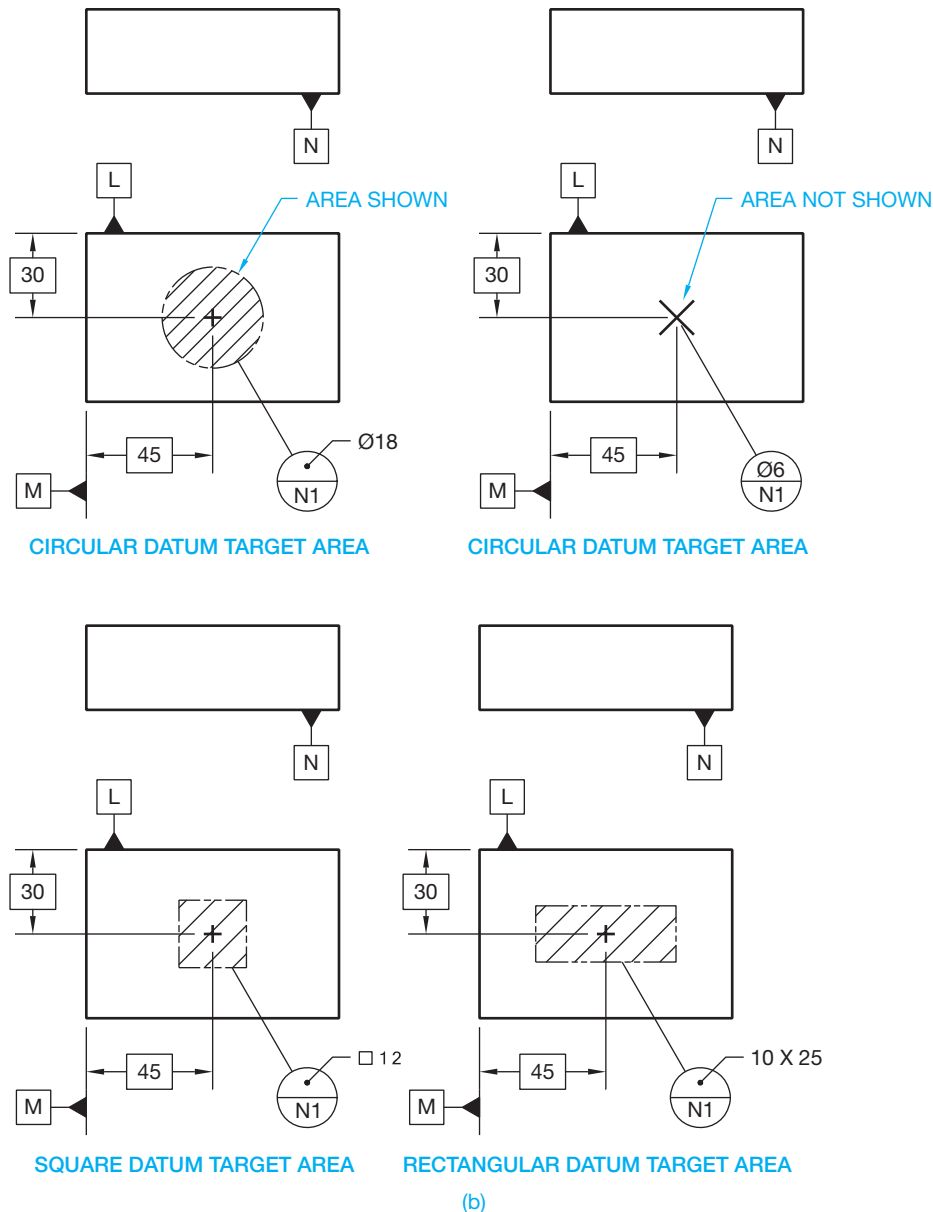


FIGURE 13.12 (Continued)

© Cengage Learning 2012

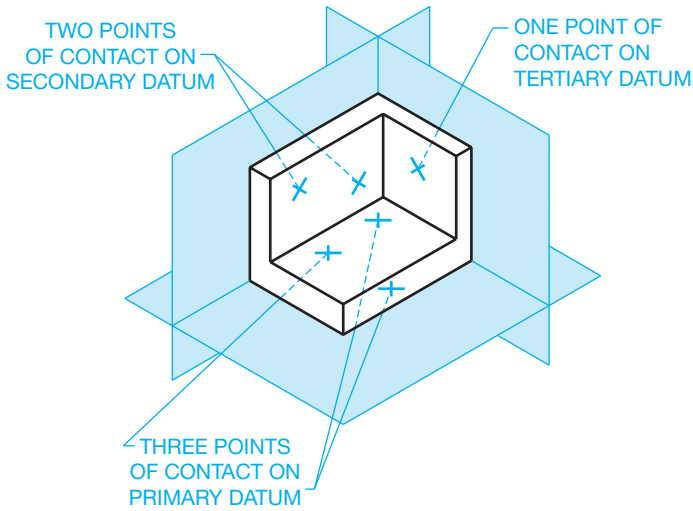
using basic or tolerance dimensions. Established tooling or gauging tolerances apply when datum targets are located with basic dimensions. Datum targets are established on the part with fixtures and with pins. These pins contact the part where the datum targets are specified. Figure 13.13 shows a pictorial drawing of the datum target points on the primary, secondary, and tertiary datums.

### Locating Datum Target Points

Datum target points can be located with **basic dimensions** or tolerance dimensions. Figure 13.14 shows a multiview representation using basic dimensions to locate the datum target points. Locating datum target points using datum dimensioning

with basic dimensions. Chain dimensions and tolerance dimensions can also be used.

**Basic Dimensions**—A basic dimension is considered a theoretically perfect dimension. Basic dimensions are used to describe the theoretically exact size, profile, orientation, or location of a feature or datum target. Basic dimensions provide the basis from where permissible variations are established by tolerances on other dimensions, in notes, or in feature control frames. In simple terms, a basic dimension does tell you where the geometric tolerance zone or datum target is located. This text will show you specific situations where basic dimensions are optional or required. Basic dimensions are shown on a drawing by placing a rectangle (box) around the dimension as shown in Figure 13.15.

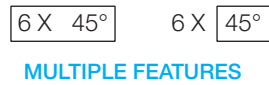
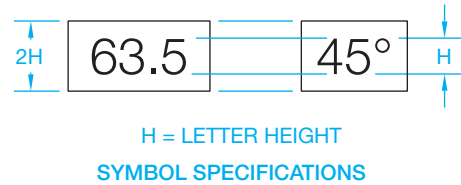


**FIGURE 13.13** Datum target points on primary, secondary, and tertiary datums. © Cengage Learning 2012

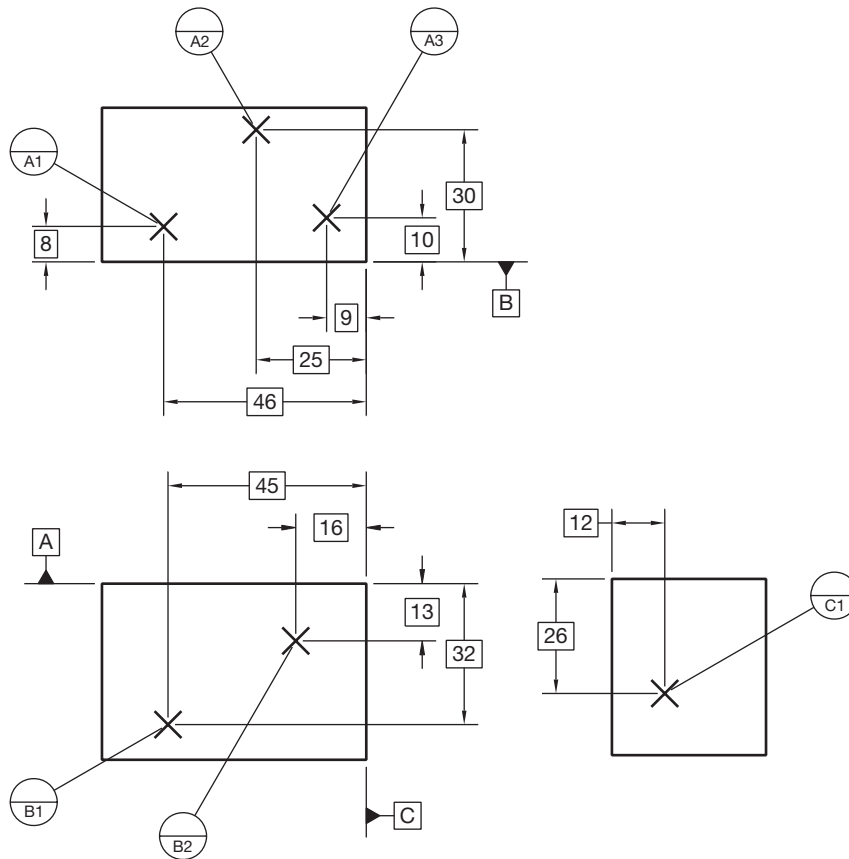
### Locating Datum Target Areas

When datum target areas are used, the shape of the datum target area is outlined by phantom lines with section lines through the area. Circular areas are dimensioned with basic or tolerance

dimensions to locate the center. The diameter of the target area is provided in the upper half of the datum target symbol, as shown in Figure 13.12b, or with a leader and dot pointing to the upper half. The locating pins for target areas are flat-end tooling pins with the pin diameter equal to the specified size of the target area. When the area is too small to accurately or clearly display on a drawing, then a datum target point is used at the center location. The top half of the datum target symbol identifies the diameter of the target area as shown in Figure 13.12b.



**FIGURE 13.15** The basic dimension symbol is a thin line box placed around the dimension value. When dimensioning multiple features, the number of places or times can be applied inside or outside the basic dimension symbol.



**FIGURE 13.14** Locating datum target points using baseline dimensioning with basic dimensions. Chain dimensions and tolerance dimensions can also be used.

### Locating Datum Target Lines

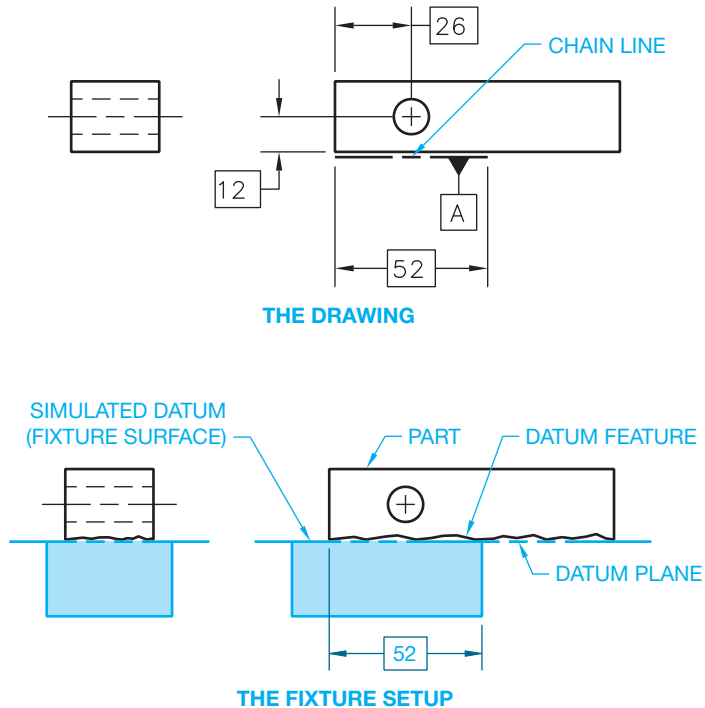
A datum target line is indicated by the target point symbol X on the edge view of the surface and by a phantom line on the surface view (see Figure 13.12b). If the locating pins are cylindrical, then the datum target line is along the tangency where the pins meet the part. The pins can also be knife-edged. A surface is often placed at 90° to the pin to create the datum reference frame.

### Establishing a Partial Datum Surface

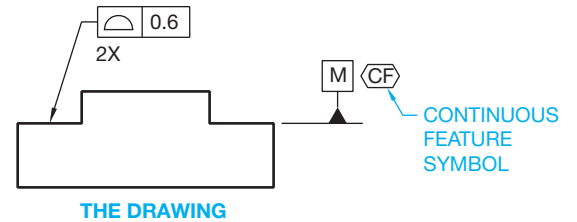
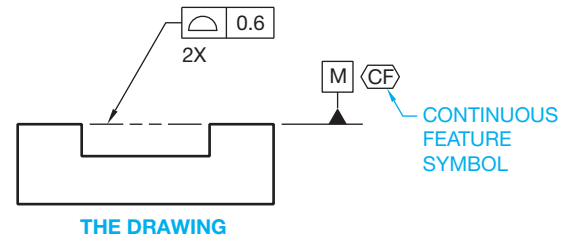
A portion of a surface can be used as a datum. For example, this can be done when a part has a hole or group of holes at one end where it is not necessary to establish the entire surface as a datum to locate the features effectively. This can be accomplished on a drawing using a chain line dimensioned with basic dimensions to show the location and extent of the partial datum surface. The chain line dimension is considered a minimum distance. The datum feature symbol is attached to the chain line. The datum plane is then established at the location of the chain line as shown in Figure 13.16.

### Establishing Coplanar Datum Surfaces

**Coplanar surfaces** are two or more surfaces that are on the same plane. The relationship of coplanar datum features establishes



**FIGURE 13.16** A partial datum surface established with a chain line.  
© Cengage Learning 2012



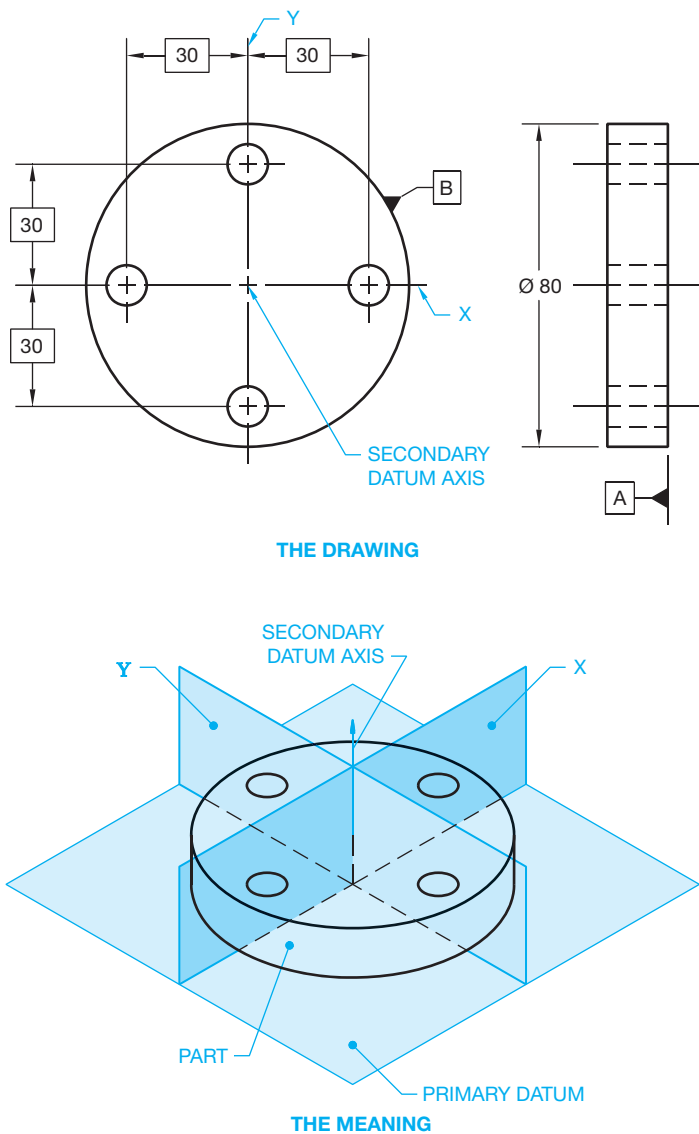
**FIGURE 13.17** Coplanar surface datums represented using the continuous feature symbol and using a note 2X below the feature control frame to indicate the number of coplanar surfaces. (a) Coplanar surfaces with a void between surfaces. (b) Coplanar surfaces with a feature between surfaces. © Cengage Learning 2012

the surfaces as one datum plane in correlated feature control frame specifications. A phantom line is placed between the surfaces if a void, such as a slot, exists. The phantom line between surfaces is omitted when the area between the surfaces is higher than the datum features. The surfaces are treated as a single, interrupted surface. The number of surfaces can be specified as continuous by using the continuous feature symbol or by using a note, such as 2X, below the related feature control frame. When the continuous feature symbol is used, an extension line can be placed between the continuous features or omitted. The datum reference in the **feature control frame** gives both datum letters separated by a dash (see Figure 13.17). The continuous feature symbol can be used to identify any group of two or more interrupted features as a single feature. A feature control frame is a symbol used to define the geometric tolerancing

characteristics of a feature. Feature control frames are described in detail later in this chapter.

### Establishing a Datum Axis

A cylindrical object can be a datum feature. When the cylindrical datum feature is used, the center axis is known as the **datum axis**. There are two theoretical planes intersecting at 90°. These planes are represented by the centerlines on the drawing. The datum axis is where these planes intersect. The datum axis is the origin for related dimensions, while the X- and Y-planes indicate the direction of measurement. A datum plane is added to the end of the object to establish the datum frame as shown in Figure 13.18.



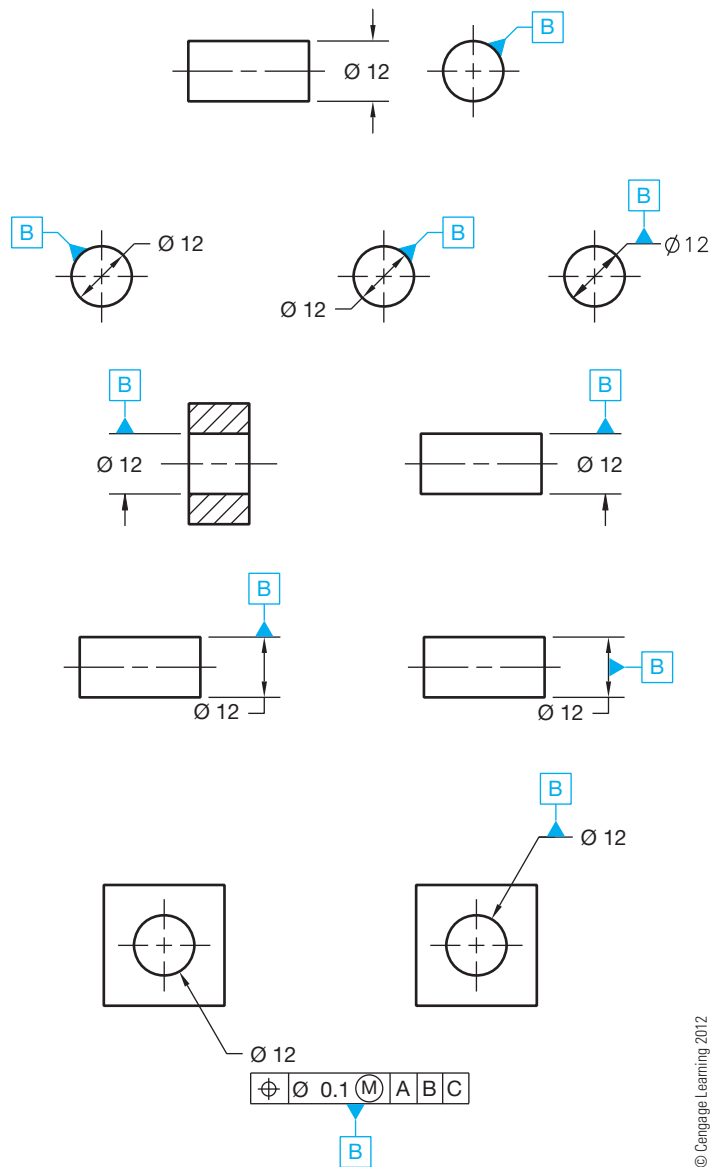
**FIGURE 13.18** The datum axis is the origin for related dimensions, whereas the X- and Y-planes indicate the direction of measurement. A datum plane is added to the end of the object to establish the datum frame. © Cengage Learning 2012

### Placement of the Datum Feature Symbol for a Datum Axis

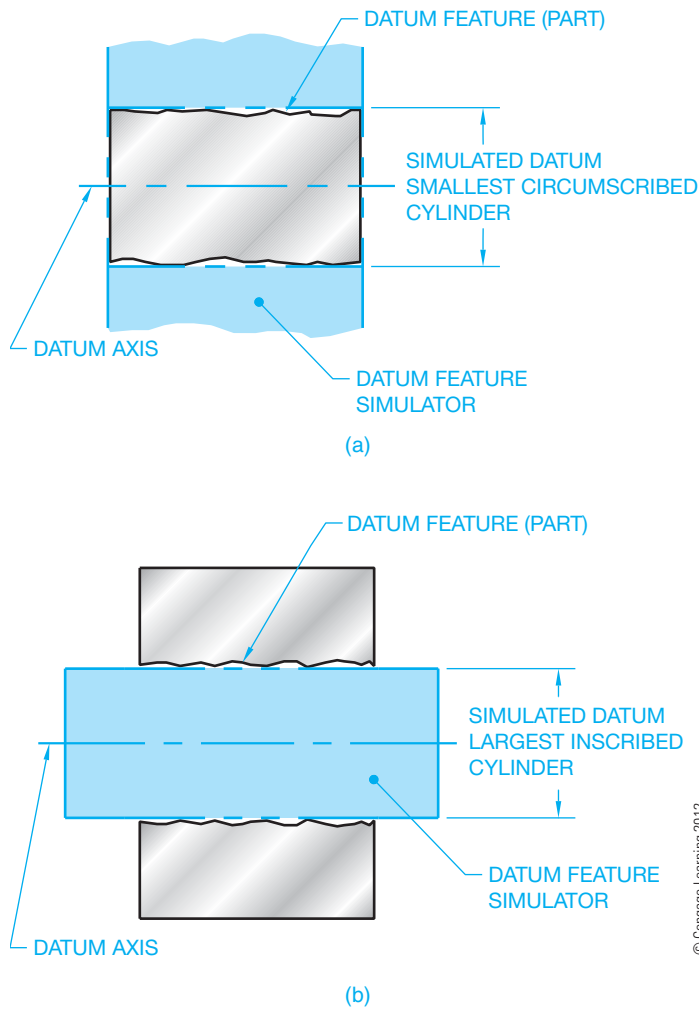
The datum feature symbol representing the datum axis can be placed on the drawing as shown in Figure 13.19.

### Simulated Datum Axis

The **simulated datum axis** is the axis of a perfectly cylindrical inspection device that contacts the datum feature surface. For an external datum feature as shown in Figure 13.20a, the inspection device is the smallest circumscribed cylinder. The inspection device for an internal datum feature is the largest inscribed cylinder as shown in Figure 13.20b.



**FIGURE 13.19** The datum feature symbol representing the datum axis can be placed on the drawing using these methods.



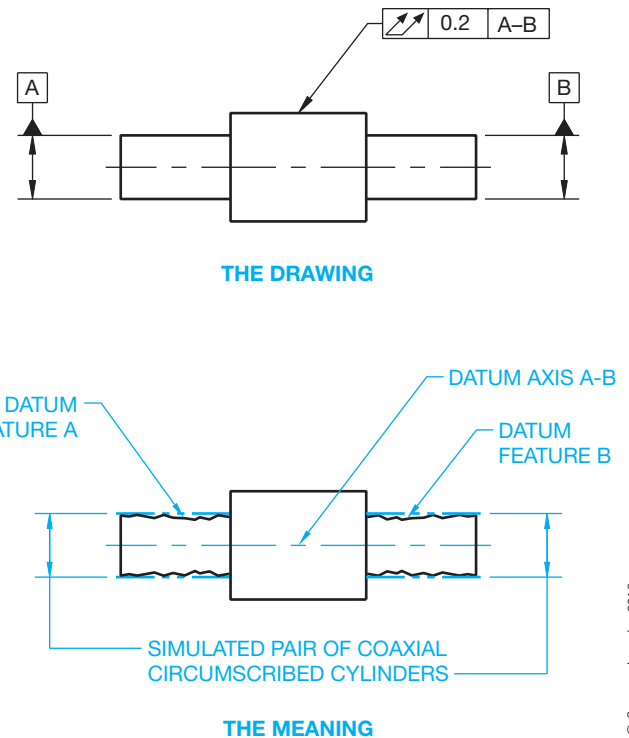
**FIGURE 13.20** (a) Simulated datum axis for an external datum feature. (b) Simulated datum axis for an internal datum feature.

### Coaxial Datum Features

**Coaxial** means two or more cylindrical shapes that share a common axis. Coaxial datum features exist when a single datum axis is established by two datum features that are coaxial. When more than one datum feature is used to establish a single datum, the datum reference letters are separated by a dash and placed in one compartment of the feature control frame. These datum reference letters are of equal importance and can be placed in any order (see Figure 13.21). A datum axis established by coaxial datum features is normally used as a primary datum.

### The Datum Axis of Screw Threads, Gears, and Splines

When a screw thread is used as a datum axis, the datum axis is established from the pitch cylinder unless otherwise specified. If another feature of the screw thread is desired, then a note such as **MAJOR DIA** or **MINOR DIA** is placed next



**FIGURE 13.21** Establishing a multiple coaxial datum axis.

to the datum feature symbol. For example, the note **MAJOR DIA** is specified when the datum axis is established from the major diameter cylinder. A specific feature such as the major diameter should be identified when a gear or spline is used as a datum axis. When this is done, the note **MAJOR DIA**, **MINOR DIA**, or **PITCH DIA** is placed next to the datum feature symbol as appropriate. The use of a screw thread, gear, or spline should be avoided for use as a datum axis unless necessary.

### Datum Axis Established with Datum Target Symbols

Datum target points, lines, or surface areas can also be used to establish a datum axis. A primary datum axis can be established by two sets of three equally spaced targets. One set is placed near one end of the cylinder and the other set near the other end as shown in Figure 13.22. Notice the datum target points in the circular view are rotated as needed to align with an imaginary line projected from the center for clarity. A secondary datum axis can be established by placing three equally spaced targets on the cylindrical surface. Cylindrical datum target areas and circular datum target lines can also be used to establish the datum axis of cylindrically shaped parts as shown in Figure 13.23. In this application, the datum target area is a designated width band that goes all around the part. This datum target area is shown as two phantom lines with section lines between. The datum target line is a phantom line that goes all around the part.



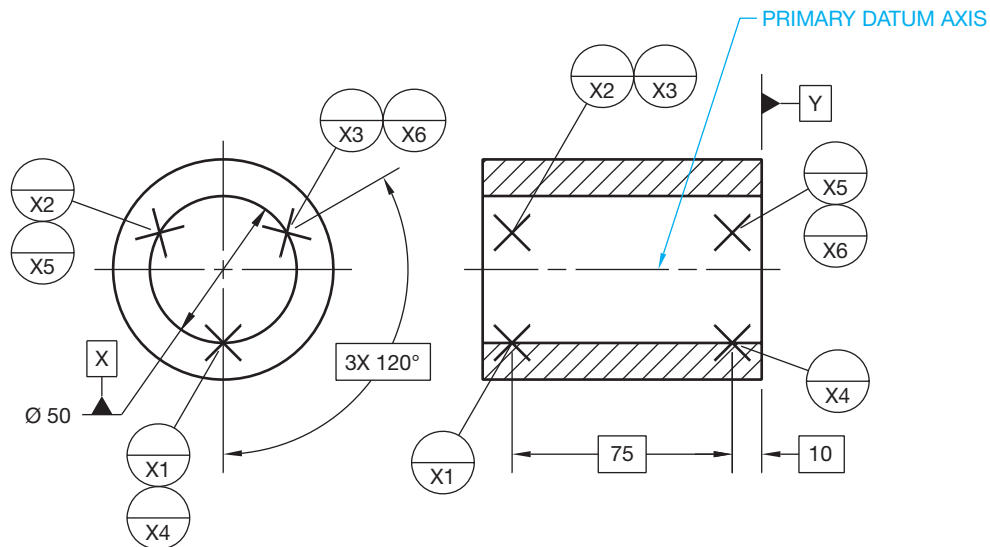


FIGURE 13.22 Establishing a primary datum axis with target points.

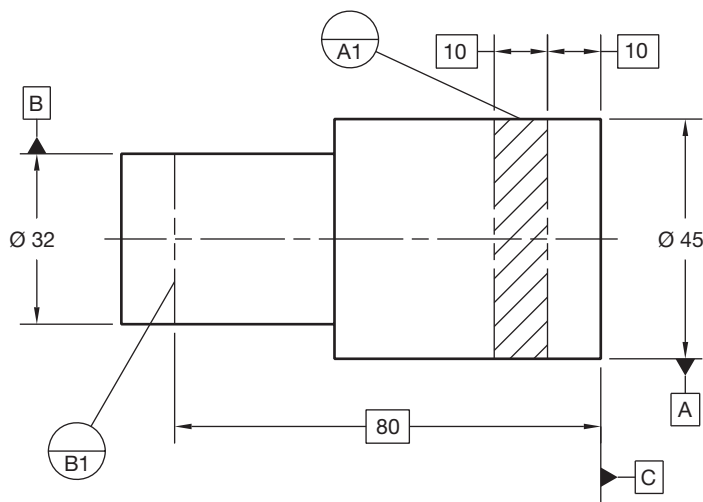


FIGURE 13.23 Establishing datum axes with a cylindrical datum target area and a circular datum target line. © Cengage Learning 2012

### Using a Movable Datum Target Symbols with Datum Target Points

The movable datum target symbol can be used to indicate movement of the datum feature simulator. When datum targets establish a center point, axis, or center plane on a **regardless of material boundary (RMB)** basis, the datum feature simulator moves **normal** to the true profile, and the movable datum target symbol can be used for clarity. The term *normal* is used in ASME Y14.5 and in mechanical engineering applications to represent a feature that is perpendicular to a plane surface and radial to a curved surface. In Figure 13.24, datum C uses movable target symbols. The part is fixed against datum target points A1, A2, and A3 primary, datum target lines B1 and B2 secondary, and datum target points C1 and C2 tertiary.

Because datums B and C are referenced in the feature control frame as RMB, the datum simulator makes contact with the part. If the actual part is manufactured to the small size tolerance, then datum target points C1 and C2 are movable in order to contact the feature part. In this case, the movable target points move along the basic 45° angle that is attached to the movable datum target symbol C1 until contact is made. This example shows how to define the direction of the movement. When the datum feature simulator is required to move and when the movement is not normal to the true profile, the movable datum target symbol is used and the movement direction is defined. If the 45° basic angle is not given, the datum target can move normal to the surface or radial toward the center of the round feature. Regardless of material, *boundary* is used to indicate that a datum is established from a datum feature simulator that progresses from the MMC boundary to the LMC boundary until it makes maximum contact with the farthest points of the feature. RMB is described in more detail later in this chapter.

### Establishing a Datum Center Plane

Elements on a rectangular, symmetrical part or feature can be located and dimensioned in relationship to a **datum center plane**. Axis and center plane datum feature symbols must align with or replace the dimension line arrowhead or be placed on the feature, leader shoulder, dimension line, or feature control frame. The representation and related meaning of datum center plane symbols are shown in Figure 13.25.

### Simulated Datum Center Plane

The **simulated datum center plane** is the center plane of a perfect rectangular inspection device that contacts the datum

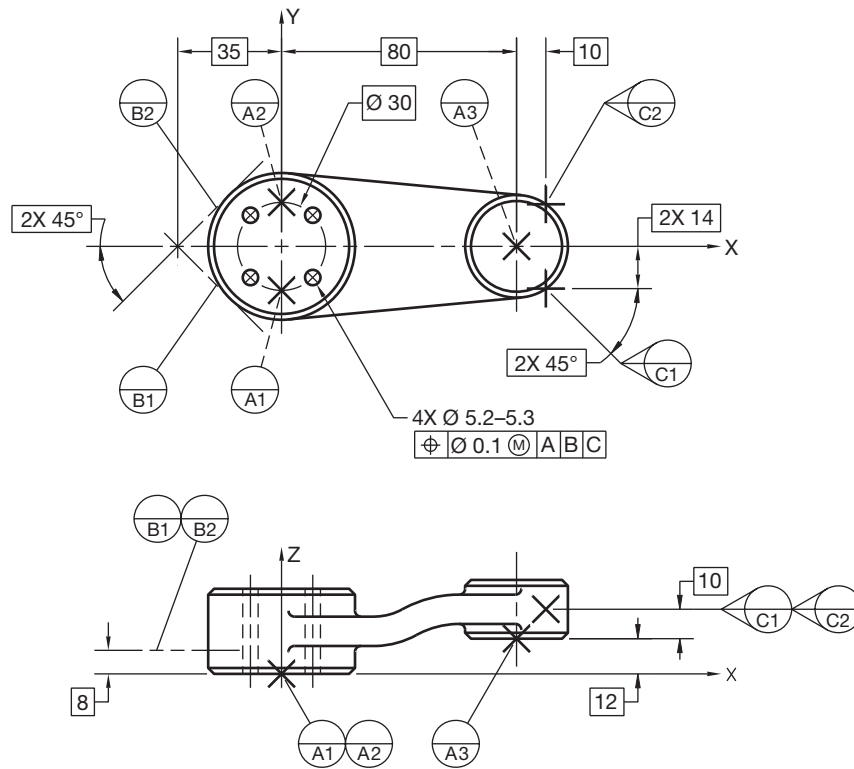


FIGURE 13.24 Using movable datum target symbols with datum target points.

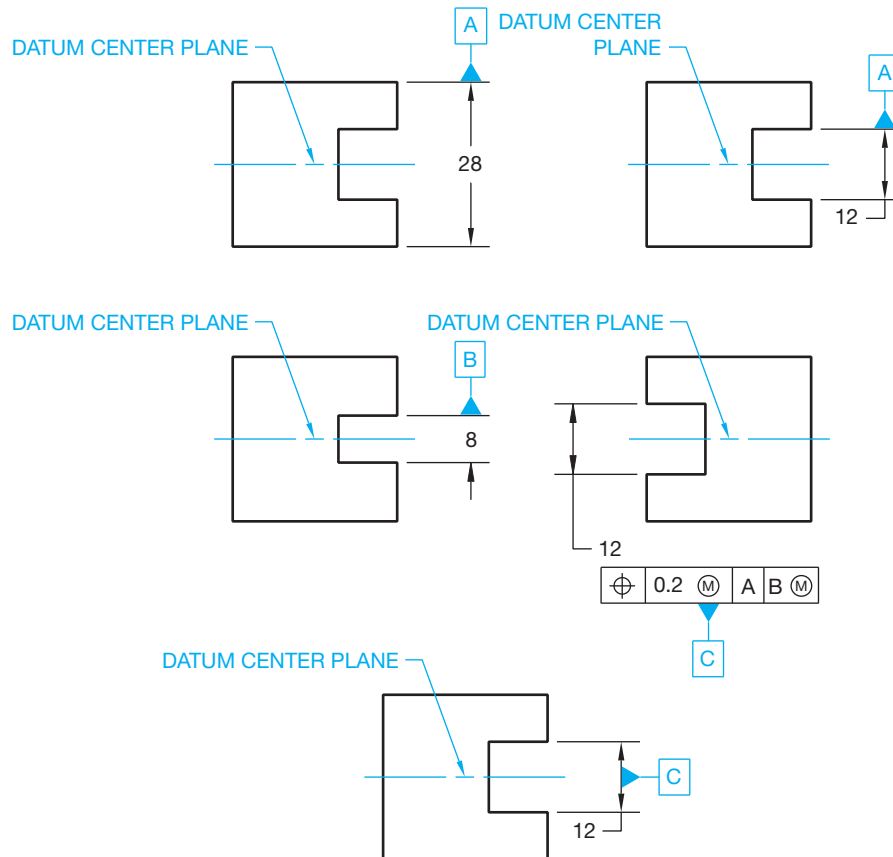
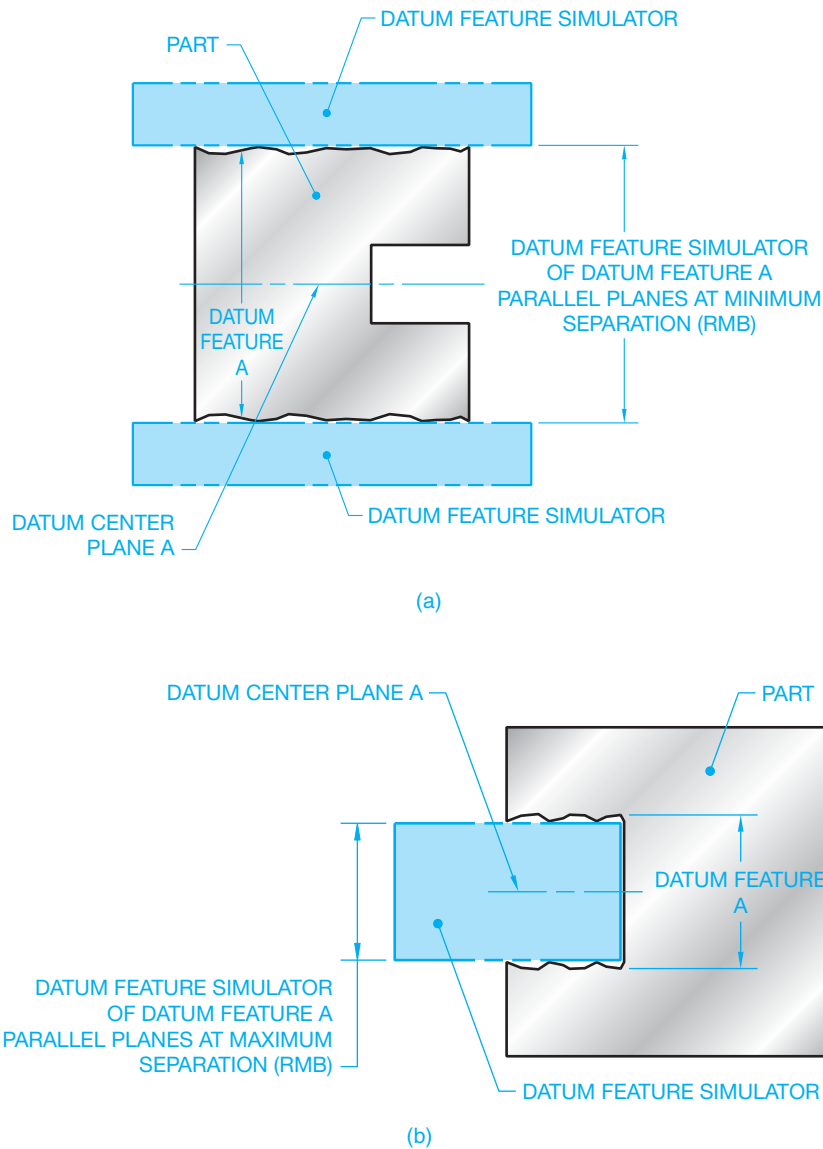


FIGURE 13.25 Placement of center plane datum feature symbols.



**FIGURE 13.26** (a) Simulated datum center plane for an external datum feature. (b) Simulated datum center plane for an internal datum feature.

feature surface. For an external datum feature, the datum center plane is established by two parallel planes at minimum (MMC) separation as shown in Figure 13.26a. For an internal datum feature, the datum center plane is established by two parallel planes at maximum (MMC) separation as shown in Figure 13.26b.

### Center of a Pattern of Features as the Datum Axis

The center of a pattern of features, such as the holes in the part shown in Figure 13.27, can be specified as the datum axis when the datum feature symbol is placed under and attached to the middle of the feature control frame. In this application, the datum axis is the center of the holes as a group.

### APPLYING MATERIAL CONDITION AND MATERIAL BOUNDARY SYMBOLS

**Material condition** and **material boundary** symbols are used in conjunction with the geometric tolerance or datum reference in the feature control frame. Material condition symbols and material boundary symbols establish the relationship between the size of the feature within its given dimensional tolerance and the geometric tolerance. The use of different material condition symbols alters the effect of this relationship. Material condition symbols are referred to as **modifiers** because they modify the geometric tolerance in relationship to the actual produced size of the feature. The **actual produced size** is the measured size after production. The material condition modifying elements are:

- Maximum material condition (MMC).
- Maximum material boundary (MMB).

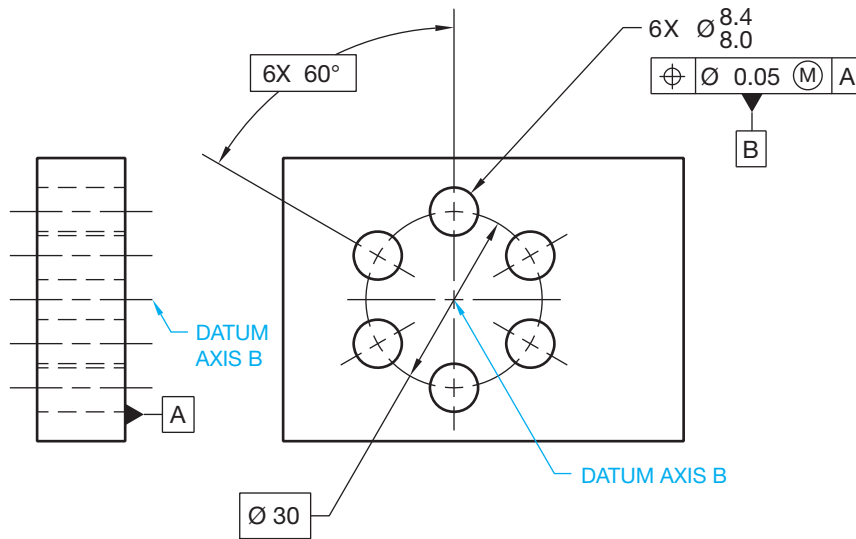


FIGURE 13.27 The datum axis at the center of a pattern of features as a group.

**SYMBOL MEANING**

- (M) AT MAXIMUM MATERIAL CONDITION (MMC) WHEN APPLIED TO A TOLERANCE VALUE. AT MAXIMUM MATERIAL BOUNDARY (MMB) WHEN APPLIED TO A DATUM REFERENCE.
- (L) AT LEAST MATERIAL CONDITION (LMC) WHEN APPLIED TO A TOLERANCE VALUE. AT LEAST MATERIAL BOUNDARY (LMB) WHEN APPLIED TO A DATUM REFERENCE.

- Regardless of feature size (RFS).
- Regardless of material boundary (RMB).
- Least material condition (LMC).
- Least material boundary (LMB).

The material condition and material boundary symbols are detailed in Figure 13.28. There are no symbols for RFS and RMB. RFS is assumed for all geometric tolerance applications, and RMB is assumed for datum references unless otherwise specified. The MMC or LMC symbols must be in the feature control frame if these applications are intended. When used, the material condition and material boundary symbols are placed after the geometric tolerance or datum reference as shown in Figure 13.29. The MMB and LMB symbols are only used if the datum feature has size.

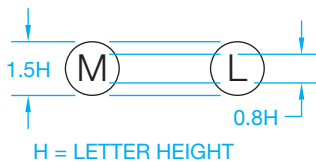


FIGURE 13.28 Material condition and material boundary symbols.

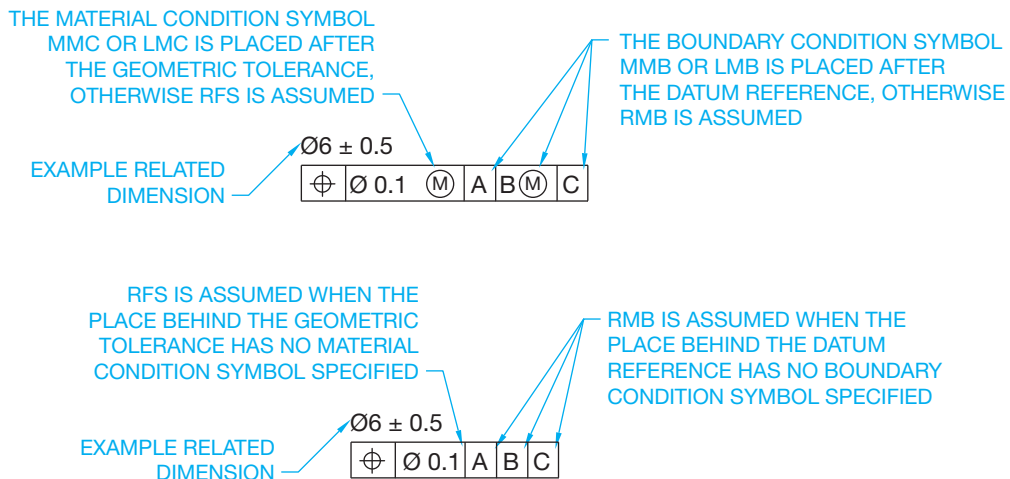
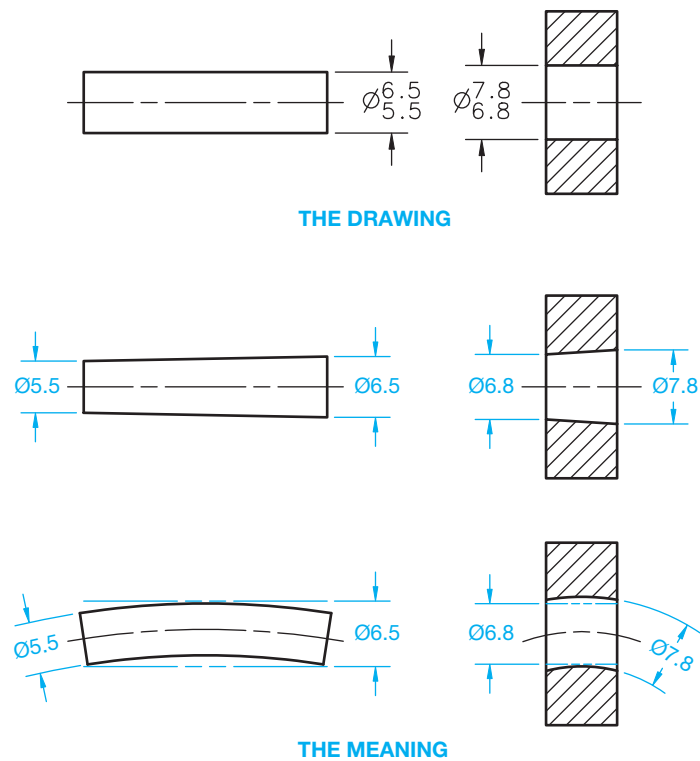


FIGURE 13.29 When used, the material condition symbols MMC and LMC are placed after the geometric tolerance in the feature control frame. The material boundary symbols MMB and LMB, when used, are placed after the datum reference in the feature control frame. If no material condition symbol or boundary condition is used, then RFS or RMB is assumed.



**FIGURE 13.30** The limits of size and representative extreme form variation of the part. © Cengage Learning 2012

## LIMITS OF SIZE APPLICATION

The **limits of a size** dimension determine the given variation allowed in the size of the feature. The part shown in Figure 13.30 has a MMC of 6.5 and a LMC of 5.5. The MMC- and LMC-produced sizes represent the limits of the dimension. The actual part can be manufactured at any size between the limits.

## PERFECT FORM BOUNDARY

The form of a feature is controlled by the size tolerance limits as shown in Figure 13.30. The boundary of these limits is established at MMC. The **perfect form boundary** is the true geometric form of the feature at MMC as shown in Figure 13.31. Therefore, if the part is produced at MMC, it must be at perfect form. If a feature is produced at LMC, the form tolerance is allowed to vary within the geometric tolerance zone to the extent of the MMC boundary.

In some applications, it is desirable to exceed the perfect form boundary at MMC. When this is done, the independency symbol must accompany the size dimension. The independency symbol is used to specify that perfect form at MMC is not required (see Figure 13.32).

## APPLYING REGARDLESS OF FEATURE SIZE AND REGARDLESS OF MATERIAL BOUNDARY

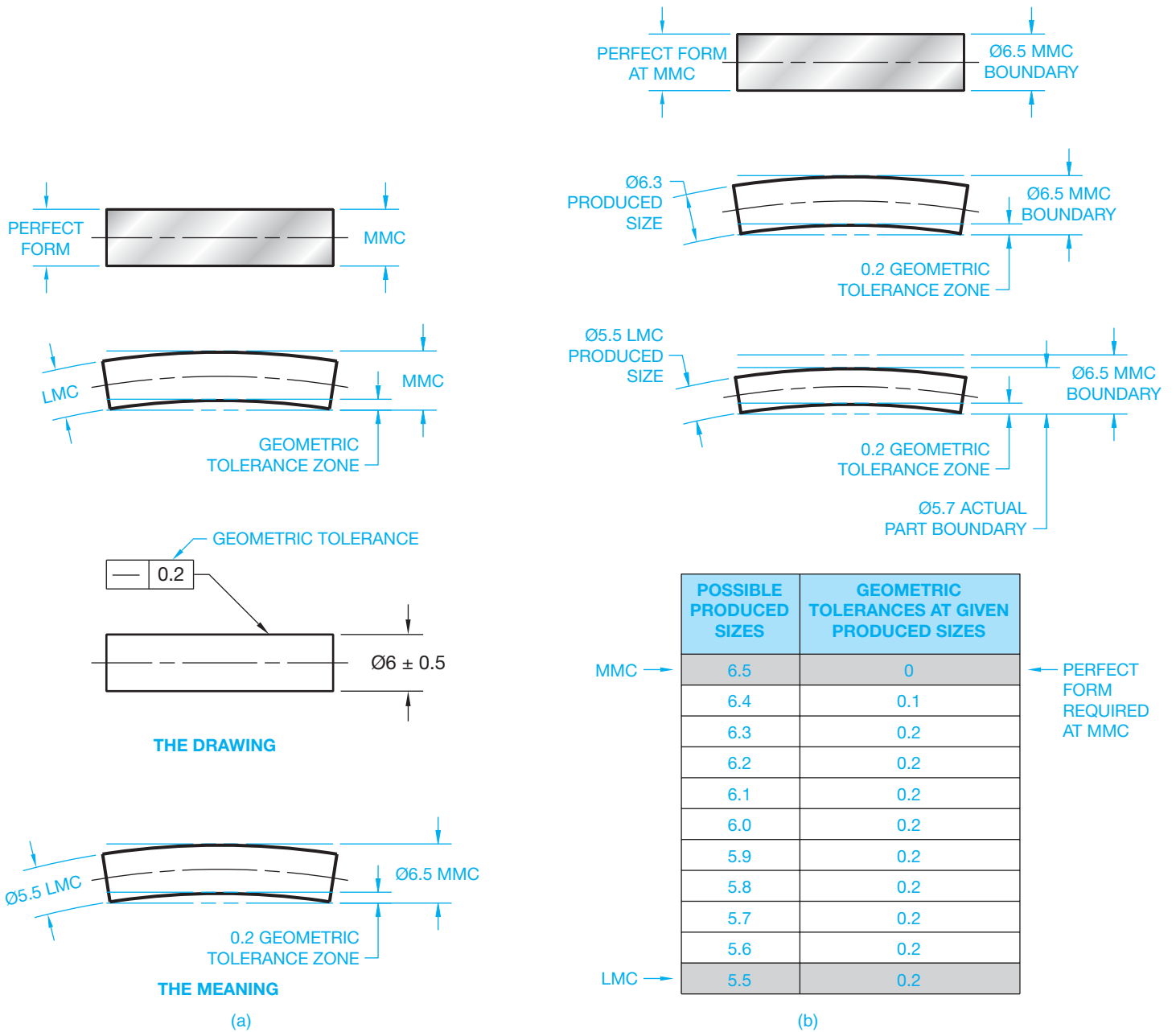
**Regardless of feature size (RFS)** is the term used to indicate that a geometric tolerance applies at any increment of size of the feature within its size tolerance. **Regardless of material boundary (RMB)** is the term used to indicate that a datum is established from a datum feature simulator that progresses from the MMB toward the LMB until it makes maximum contact with the farthest points of the feature.

The following rules govern the use of RFS and RMB: **Rule 2 in ASME Y14.5** states that RFS applies with respect to the individual geometric tolerance and RMB to the datum reference when no material condition or boundary condition symbol is specified (see Figure 13.29). MMC, LMC, MMB, and LMB must be specified in the feature control frame where required. The geometric tolerances of circularity, cylindricity, profile, circular runout, total runout, concentricity, and symmetry are applied only on an RFS basis. An MMC or LMC material condition symbol cannot be used with these geometric characteristics.

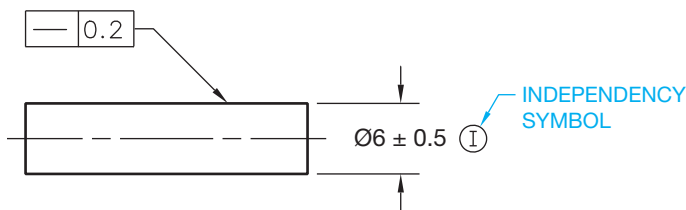
## Surface Control, Regardless of Feature Size (RFS)

Surface geometric control is when the feature control frame is either connected with a leader to the surface of the object or feature or extended from an extension line from the surface of the object or feature, and a diameter symbol is not placed in the feature control frame. The use of a leader connecting the feature control frame to the surface is shown in Figure 13.31. RFS is implied in this example, because neither MMC nor LMC is specified in the feature control frame. In addition, a surface control requires an RFS application because it is not associated with a size dimension. Only a control related to a size dimension or feature of size can have an MMC or LMC application. The surface straightness specification, shown in Figure 13.31, means that **each longitudinal element** of the surface must lie between two parallel lines 0.2 mm apart, where the two lines and the nominal axis of the part share a common plane.

The concept of each longitudinal element is based on the function of the part and the comfort level of inspection, because there is no required number of elements. In addition, the feature must be within the specified size limits and within the perfect form boundary at MMC. When the actual size of the feature is MMC, zero geometric tolerance is required. When the actual produced size departs from MMC, the geometric tolerance is allowed to increase equal to the amount of departure until the specified geometric tolerance is reached. When the geometric tolerance specified in the feature control frame is reached, the geometric tolerance stays the same at every other produced size. Figure 13.31 shows an analysis of a surface RFS.



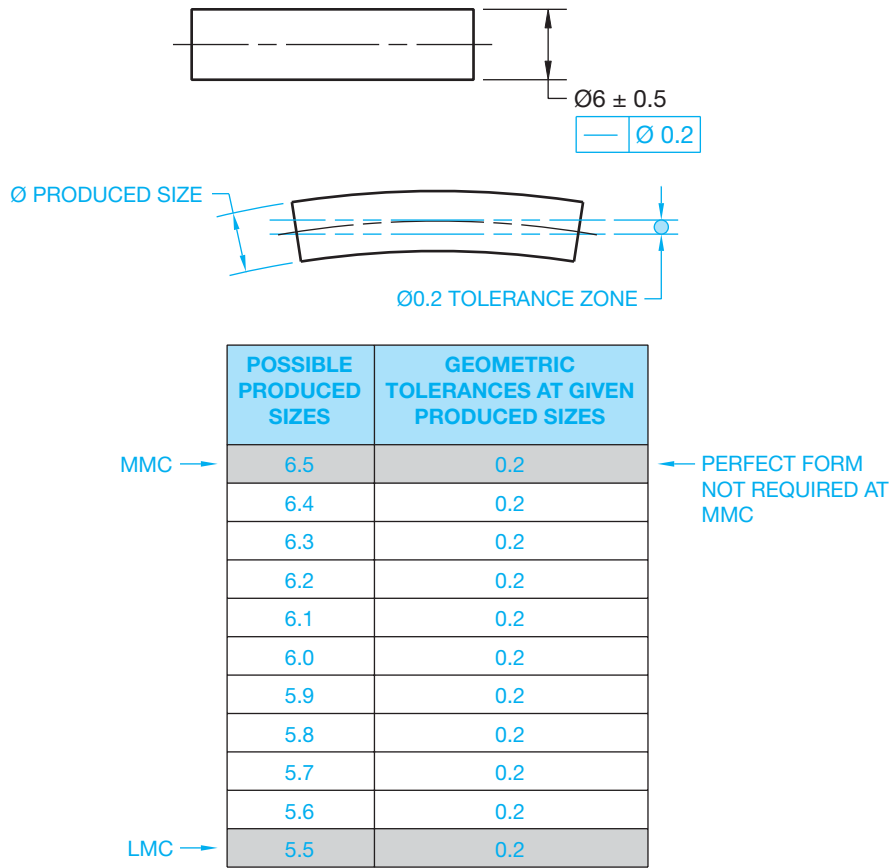
**FIGURE 13.31** The perfect form boundary and application of a geometric tolerance to the surface of the feature. (a) Application of surface control geometric tolerance. (b) Application of surface straightness at different produced sizes. Perfect form is required at MMC, and the geometric tolerance increases until the specified value is reached. The specified geometric tolerance remains the same at every other produces size until LMC is reached. © Cengage Learning 2012



**FIGURE 13.32** Using the independency symbol to indicate that perfect form of a feature of size is not required at MMC.

### Axis Control, Regardless of Feature Size

Axis geometric control is applied by placing the feature control frame with the diameter dimension of the related object or feature. When axis control is used, a diameter tolerance zone must be specified by placing the diameter symbol in front of the geometric tolerance in the feature control frame as shown in Figure 13.33. When axis control is specified, the perfect form



**FIGURE 13.33** Axis control showing straightness. The feature control frame is placed below the diameter size dimension. The effect of specifying axis straightness. RFS is assumed and perfect form is not required at MMC.

© Cengage Learning 2012

boundary can be violated. This violation is permissible when the feature control frame is associated with the size dimension. When MMC is not specified, then RFS is implied. When this situation occurs, the geometric tolerance at various produced sizes remains the same as given in the feature control frame; even at MMC. Figure 13.33 shows an analysis of axis control at RFS.

### APPLYING MAXIMUM MATERIAL CONDITION

**Maximum material condition (MMC)** is the condition in which a feature contains the maximum amount of material within the stated limits of size. When MMC is used in the feature control frame, the given geometric tolerance is maintained when the feature is produced at MMC. Then as the actual produced size departs from MMC, the geometric tolerance is allowed to get larger equal to the amount of departure from MMC. Think of using the MMC material condition symbol as meaning at MMC. In other words, the specified geometric tolerance is held only at the MMC-produced size. The MMC material condition application is commonly used when controlling a feature of size. One of the following formulas can be used to calculate the geometric

tolerance at any produced size when a MMC material condition symbol is used. The formula you should use is determined by whether the part is an external feature, such as a shaft, or an internal feature, such as a hole.

#### EXTERNAL FEATURE

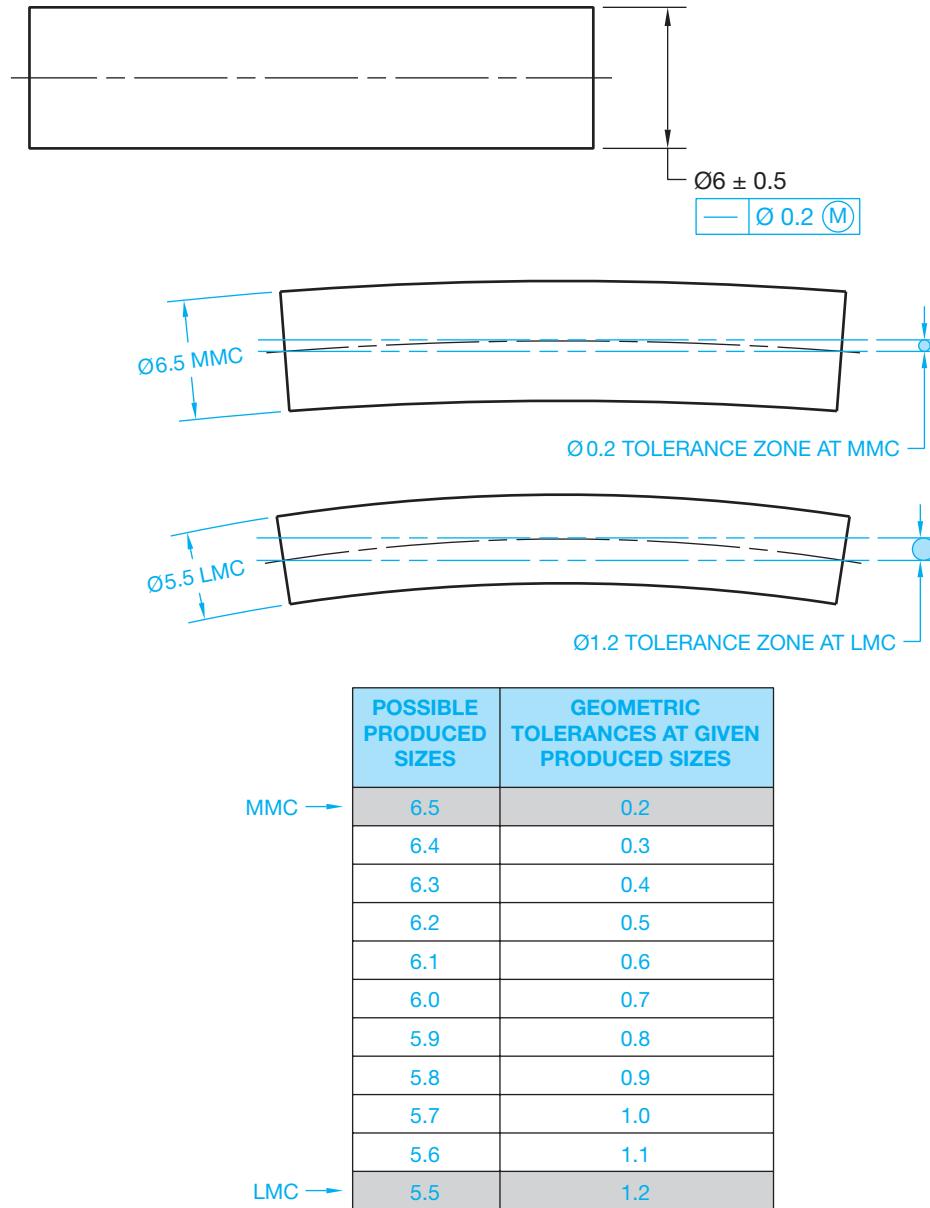
$$\text{MMC} - \text{Produced size} + \text{Given geometric tolerance} = \text{Applied geometric tolerance}$$

#### INTERNAL FEATURE

$$\text{Produced size} - \text{MMC} + \text{Given geometric tolerance} = \text{Applied geometric tolerance}$$

### Axis Control, Maximum Material Condition (MMC)

When it is desirable to use MMC as the material condition symbol, then the MMC symbol must be placed in the feature control frame after the geometric tolerance. Axis control is also a diameter tolerance zone and the diameter symbol must precede the geometric tolerance as shown in Figure 13.34. When a MMC material condition symbol is used, the geometric tolerance is the same as specified in the feature control frame at the MMC-produced size. Then, as the produced size departs from



**FIGURE 13.34** Axis control showing straightness with the MMC material condition symbol applied. The feature control frame is placed below the diameter size dimension. The effect of specifying axis straightness with the MMC material condition symbol used.

© Cengage Learning 2012

MMC, the geometric tolerance is allowed to increase equal to the amount of departure from MMC. For example, the geometric tolerance at MMC in Figure 13.34 is 0.2. If the part is produced at MMC (6.5), the geometric tolerance is 0.2. If the part is produced at 6.1, then the applied geometric tolerance is

$$\text{MMC (6.5)} - \text{Produced size (6.1)} + \text{Given geometric tolerance (0.2)} = \text{Applied geometric tolerance (0.6)}$$

The maximum geometric tolerance is at the LMC-produced size. LMC is the condition where a feature of size contains the least amount of material within the limits. The axis control at MMC application is shown in Figure 13.34.

### RFS and MMC Control on Noncylindrical Features

The concepts of surface and axis straightness previously discussed can also be applied on an RFS or MMC basis to noncylindrical features of size. However, straightness controls line elements. Flatness should be used to control the surface or center plane with a tolerance zone between two parallel planes. When this is done, the derived center plane must lie in a geometric tolerance zone between two parallel planes separated by the amount of the dimensional tolerance. Otherwise, the feature control frame placement is the same as previously discussed. The diameter tolerance



zone symbol is not used in front of the geometric tolerance, because the tolerance zone is noncylindrical and established by two parallel planes. This is described later in this chapter.

### APPLYING LEAST MATERIAL CONDITION

**Least material condition** (LMC) is the condition where the feature of size contains the least amount of material. For example, minimum shaft diameter or maximum hole diameter are both conditions of LMC. LMC is the opposite of MMC. When an LMC symbol is used in the feature control frame, the given geometric tolerance is held at the LMC-produced size. When the actual produced size departs from LMC toward MMC, the geometric tolerance is allowed to increase equal to the amount of departure. The maximum geometric tolerance is at the MMC-produced size. The formula for calculating the applied geometric tolerance in an LMC application is based on the relationship to an external or internal feature as follows:

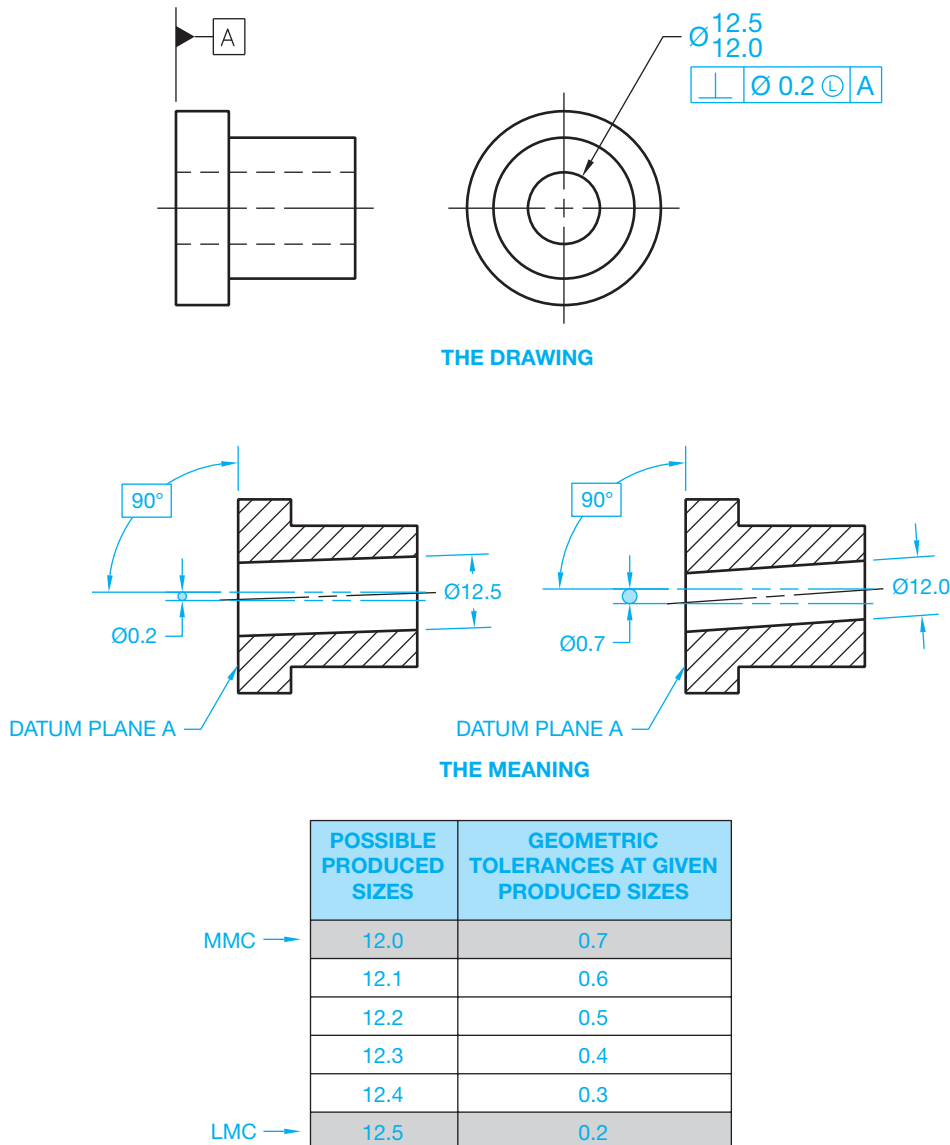
#### EXTERNAL FEATURE

$$\text{Produced size} - \text{LMC} + \text{Given geometric tolerance} = \text{Applied geometric tolerance}$$

#### INTERNAL FEATURE

$$\text{LMC} - \text{Produced size} + \text{Given geometric tolerance} = \text{Applied geometric tolerance}$$

Figure 13.34 shows an application of LMC in the feature control frame where the axis perpendicularity of a hole must be within a 0.2 diameter geometric tolerance zone, at LMC, to datum A. When the feature size is at LMC (12.5), the geometric tolerance is held as specified in the feature control frame. As the actual produced size decreases toward MMC, the geometric tolerance increases equal to the amount of change from LMC to the maximum change at MMC. The analysis in Figure 13.35 shows the possible geometric tolerance variation from LMC to MMC. This specification is often used to control the minimum



**FIGURE 13.35** The effect of specifying axis perpendicularity with the LMC material condition symbol used. The analysis shows the possible geometric tolerance variation from LMC to MMC.

wall thickness of the part. There is no requirement for the feature to maintain perfect form when produced at its LMC limit of size when an LMC material condition symbol is specified. The feature is permitted to vary from true form to the maximum variation allowed by the perfect form boundary at MMC.

## APPLICATION OF RMB ON A PRIMARY DATUM FEATURE

Datum features, such as diameters and widths that are influenced by size variations are also subject to variations in form. RMB is implied in these cases unless otherwise specified. When a datum feature has a size dimension and a geometric form tolerance, the size of the simulated datum is the MMB size limit. This applies in all cases except for axis straightness, where the boundary is allowed to exceed MMB. When a datum feature of size is represented on an RMB basis, the datum is established by contact between the datum feature surface and the surface of processing equipment, such as a centering device. The processing equipment establishes the datum axis or center plane because it acts as the true geometric match or counterpart of the datum feature. When a datum axis is primary and applied at RMB, the simulated datum is the axis of the processing equipment and is called the *datum feature simulator*. The datum feature simulator for an external feature is the smallest circumscribed perfect cylinder that contacts the datum feature surface as shown in Figure 13.36. Imagine this as placing a cylinder around the datum feature until the cylinder closes in on and touches the high points of the datum feature.

When a datum center plane is primary and applied at RMB, the simulated datum is the center plane of the datum feature simulator. The datum feature simulator for an external feature is two parallel planes that contact the datum feature surface at minimum separation. Imagine this as closing vise jaws down on the datum surface until the jaws touch the high points of the datum feature. The datum feature simulator for an internal feature is two parallel planes at maximum separation. Imagine

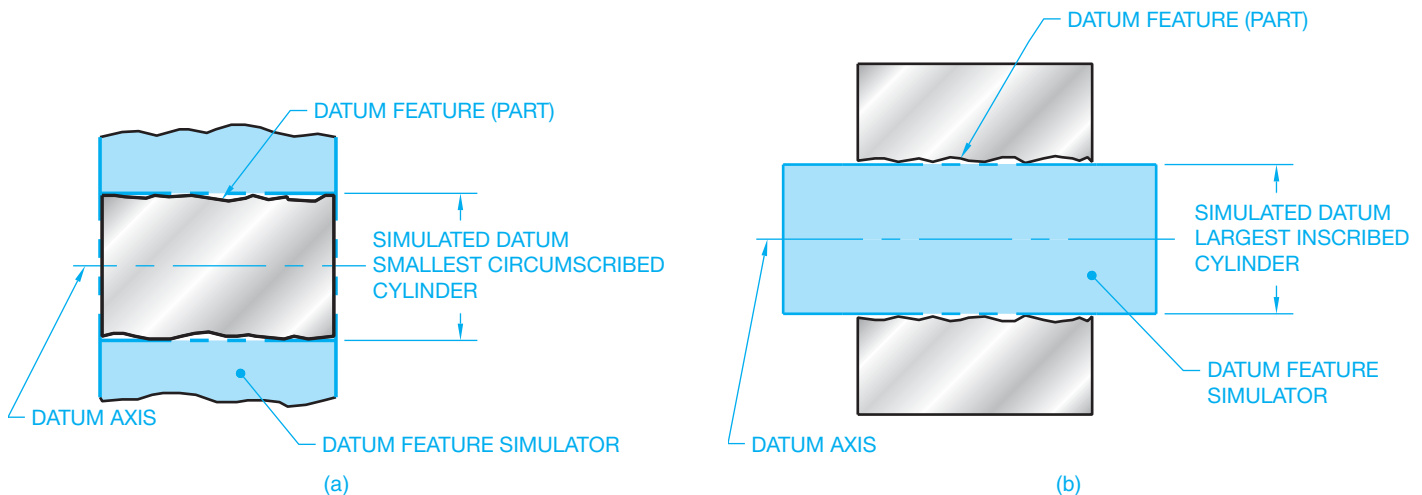
this as opening two parallel plates until the plates touch the high points of the datum feature.

## APPLICATION OF RMB ON A SECONDARY AND TERTIARY DATUM FEATURE

The secondary datum for either an axis or center plane is established in the same manner as previously discussed for the primary datum axis or center plane with this additional requirement: The contacting cylinder or parallel planes of the datum feature simulator must be  $90^\circ$ , or another design angle, to the primary datum. The primary datum is usually an adjacent plane. The tertiary datum for either an axis or center plane is established in the same way as just discussed for the secondary datum axis or center plane with this additional requirement: The contacting cylinder or parallel planes of the datum feature simulator must be  $90^\circ$ , or another design angle, to both the primary and secondary datums. The tertiary datum feature can be oriented with a datum axis or offset from a plane of the datum reference frame.

## THE EFFECT OF DATUM PRECEDENCE AND MATERIAL CONDITION

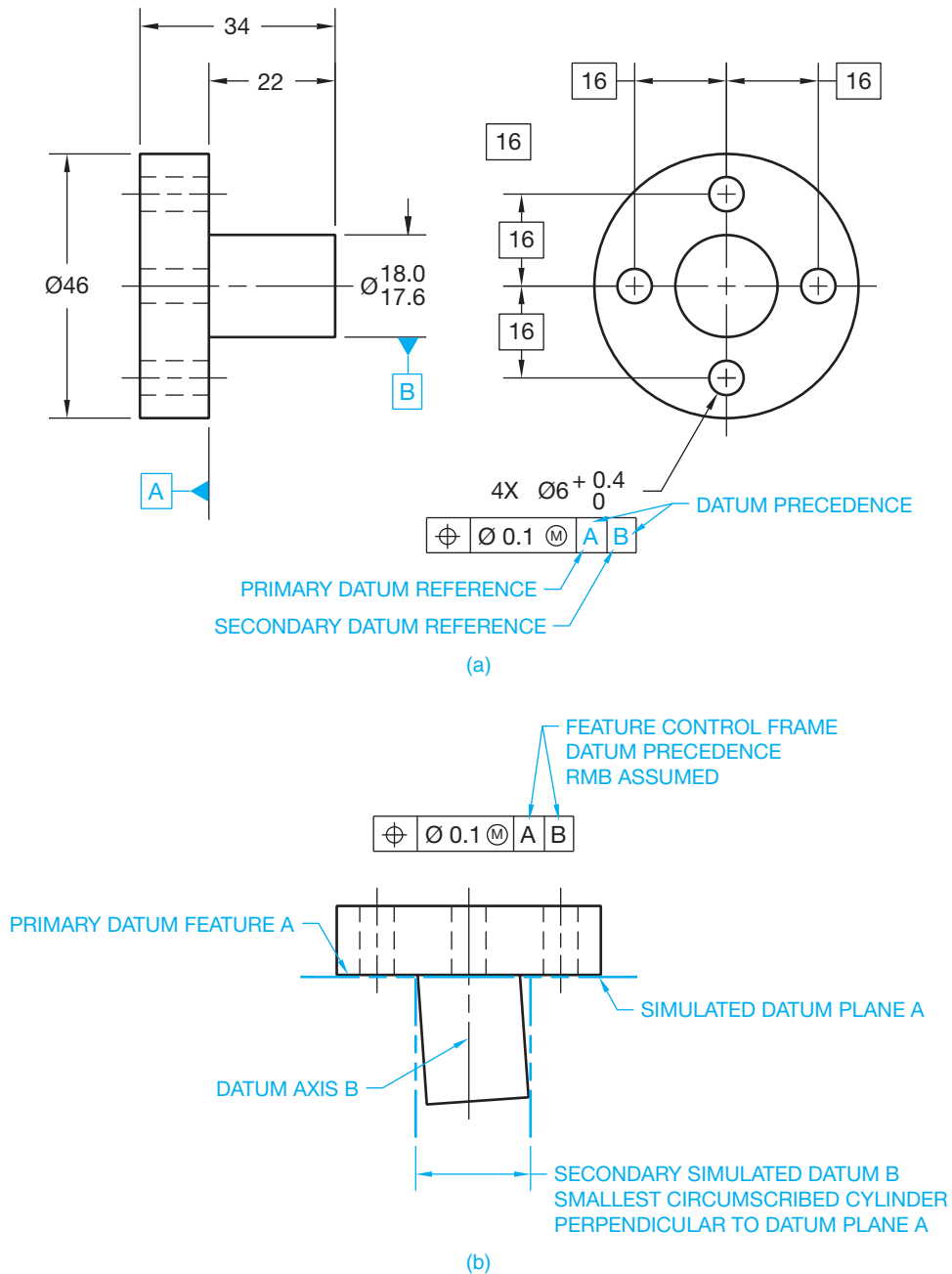
The effect of **material condition** on the datum and related feature can be altered by changing the datum precedence and the applied material condition symbol. **Datum precedence** is established by the order of datum identification placement in the feature control frame. The first datum listed is the primary datum, and it is followed by the secondary and tertiary datums. Change in size and form is allowed by the size tolerance of the datum feature. It is important to determine the datum precedence and material condition, because these changes alter the fit and design function of the part. The drawing in Figure 13.37a shows a part with a pattern of holes located in relation to the surface datum A and the axis datum B. The datum



**FIGURE 13.36** (a) The datum feature simulator for an external feature is the smallest circumscribed perfect cylinder that contacts the datum feature surface. (b) The datum feature simulator for an internal feature is the largest inscribed perfect cylinder that contacts the datum feature surface.

requirements for the position tolerance associated with the location of the four holes can be specified in three different ways, as described next. Figure 13.37b shows the surface datum A as primary and the axis datum B as secondary. Datum plane A is established first, followed by datum axis B. Datum axis B is established by the datum feature simulator of datum Feature B, which is the smallest circumscribed cylinder perpendicular to datum plane A. Figure 13.37c shows the axis datum B as primary and the surface datum A as secondary. Datum axis B is established first followed by datum surface A. Datum axis B is established by the datum feature simulator of datum feature B, which is the smallest circumscribed cylinder perpendicular to datum plane A. Figure 13.37d shows the surface datum A as primary and the axis datum B as secondary, with a MMB material condition applied to datum B. Datum plane A is established first, followed by datum axis B.

established first followed by datum surface A. Datum axis B is established by the datum feature simulator of datum feature B, which is the smallest circumscribed cylinder. Datum plane A is perpendicular to datum axis B. The MMC material condition is commonly applied to a feature of size, such as a hole or pin, when it is identified as a datum feature. Figure 13.37d shows the surface datum A as primary and the axis datum B as secondary, with a MMB material condition applied to datum B. Datum plane A is established first, followed by datum axis B.



**FIGURE 13.37** (a) A part with a pattern of holes located in relation to the surface datum A and the  $\varnothing 18.0/17.6$  axis datum B. (b) The surface datum A is represented as primary, and the axis datum B is secondary. (c) The axis datum B is shown as primary, and the surface datum A is secondary. (d) The surface datum A is represented as primary, and the axis datum B is secondary with an MMB material condition.

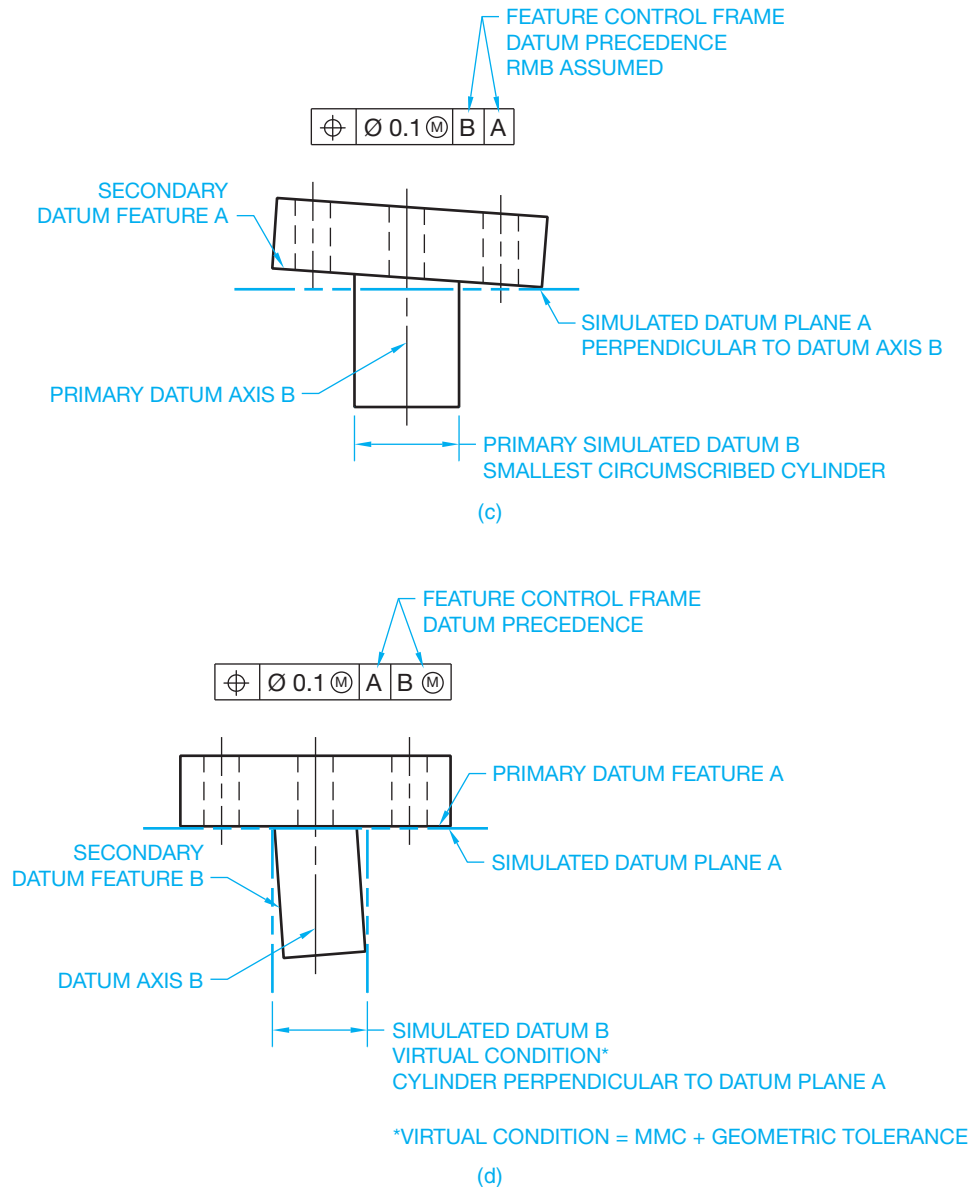


FIGURE 13.37 (Continued)

Datum axis B is established by the datum feature simulator of datum feature B, which is a cylinder equal in diameter to **virtual condition** and perpendicular to datum plane A. Virtual condition is the combined MMC and geometric tolerance, which is a boundary that takes into consideration the combined effect of feature size at MMC and geometric tolerance. Virtual condition establishes a working zone that is used to determine gage member sizes and the MMC size of mating parts or fasteners for mating parts. The virtual condition represents extreme conditions at MMC plus or minus the related geometric tolerance. For an external feature, virtual condition is equal to MMC plus the geometric tolerance as shown in Figure 13.36d. For an internal feature, virtual condition is equal to MMC minus the geometric tolerance. Virtual condition is used to determine clearance between mating parts as described later in this chapter.

## INTRODUCTION TO GEOMETRIC CHARACTERISTIC AND RELATED SYMBOLS

So far, you have been introduced to datum feature symbols, basic dimension symbols, and material condition and material boundary symbols. There have also been a few symbols used without being identified until now. This section introduces you to the geometric tolerancing symbols that are used extensively throughout the rest of this chapter. These symbols include the variety of geometric characteristic symbols and the feature control frame.

### Geometric Characteristic Symbols

**Geometric characteristic symbols** are symbols used in geometric dimensioning and tolerancing to provide specific controls

FORM	— STRAIGHTNESS
	▭ FLATNESS
	○ CIRCULARITY
	⊘ CYLINDRICITY
PROFILE	⤴ PROFILE OF A LINE
	⤵ PROFILE OF A SURFACE
LOCATION	⊕ POSITION
	◎ CONCENTRICITY
	≡ SYMMETRY
ORIENTATION	// PARALLELISM
	⊥ PERPENDICULARITY
	∠ ANGULARITY
RUNOUT	↗ OR ↘ CIRCULAR RUNOUT
	↗↘ OR ↗↘ TOTAL RUNOUT

© Cengage Learning 2012

FIGURE 13.38 Geometric characteristic symbols.

related to the form of an object, the orientation of features, the outlines of features, the relationship of features to an axis, or the location of features. Geometric characteristic symbols are separated into five types: form, profile, orientation, location, and runout as shown in Figure 13.38. The symbols in Figure 13.38 are drawn to the actual shape recommended by ASME Y14.5. Symbol sizes and specifications are identified where they apply and based on .12 in. (3 mm) lettering height.

### The Feature Control Frame Symbol

A geometric characteristic, geometric tolerance, modifiers, and datum reference (if any) for an individual feature are specified by means of a feature control frame. The feature control frame is divided into compartments containing the geometric characteristic symbol in the first compartment followed by the geometric tolerance. Where applicable, the geometric tolerance is preceded by the diameter symbol or spherical diameter symbol that describes the shape of the tolerance zone. The geometric tolerance is followed by a material condition modifier, if other than RFS. Figure 13.39 shows feature control frame applications with geometric characteristic symbol, geometric tolerance, diameter symbol (when used), and material condition modifier (when used).

Where a geometric tolerance is related to one or more datums, the datum reference letters are placed in feature control frame compartments following the geometric tolerance. A multiple datum reference is established by two datum features, such as an axis established by two datum diameters. Where a datum reference is multiple, both datum reference letters, separated by a dash, are placed in a single compartment after the geometric tolerance. Figure 13.40 shows several feature control frames with datum references.

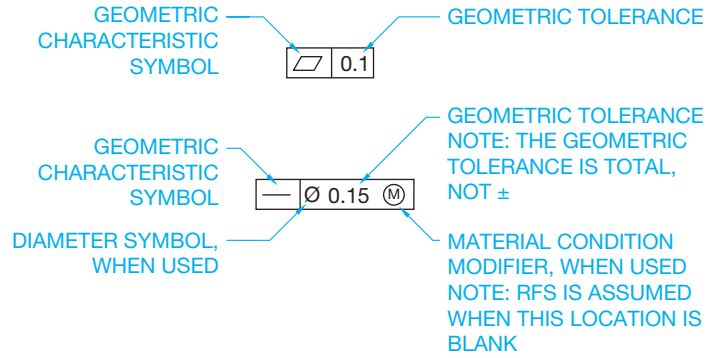


FIGURE 13.39 Feature control frame with geometric characteristic symbol, geometric tolerance, diameter symbol (when used), and material condition modifier (when used). © Cengage Learning 2012

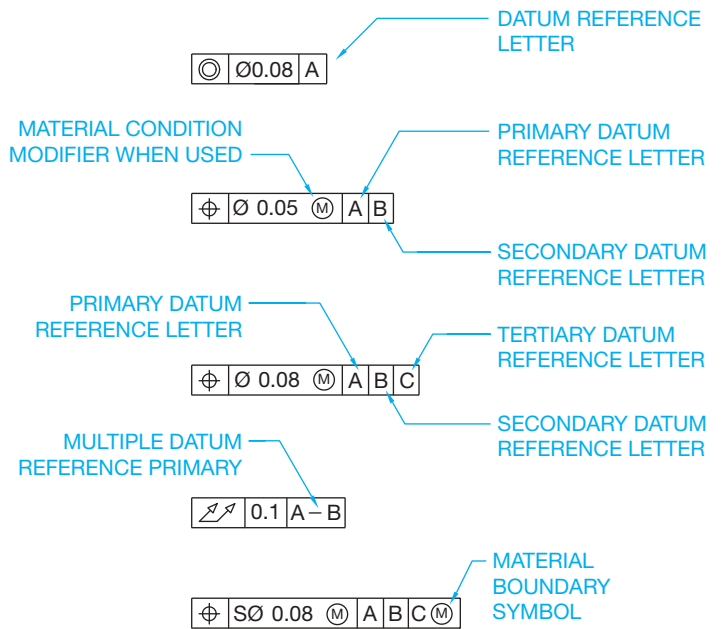
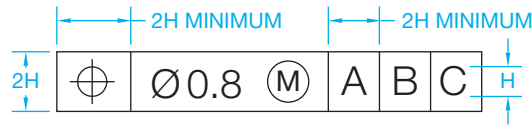


FIGURE 13.40 Feature control frame applications with datum references. © Cengage Learning 2012

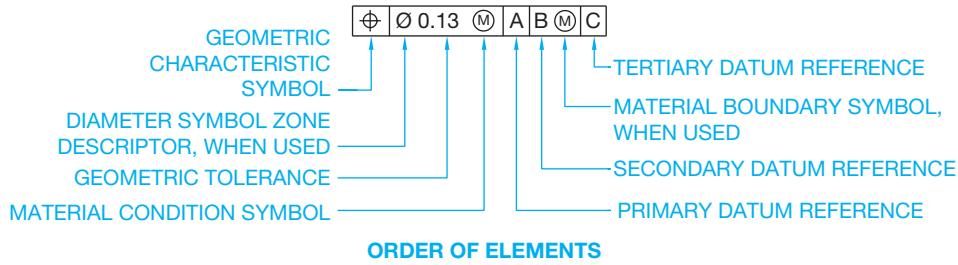
The order of elements in a feature control frame is shown in Figure 13.41. Notice that the datum reference letters are followed by a material boundary symbol where applicable. Draw each feature control frame compartment large enough to accommodate the symbols without crowding. Minimum compartment length is 2X the lettering height. Maintain the minimum compartment sizes when the symbols or letters fit without crowding.

### Additional Symbols

There are other symbols used in geometric dimensioning and tolerancing that you will see as you continue through this chapter. Some of these symbols were introduced in Chapter 10, *Dimensioning and Tolerancing*, and others are defined and used throughout the rest of this chapter. These symbols are used for specific applications and are identified as follows (see Figure 13.42).



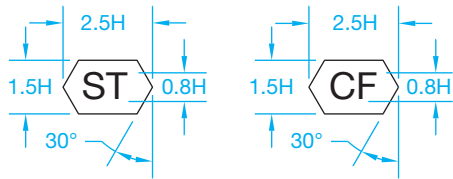
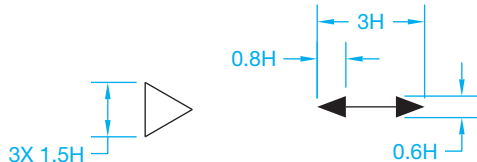
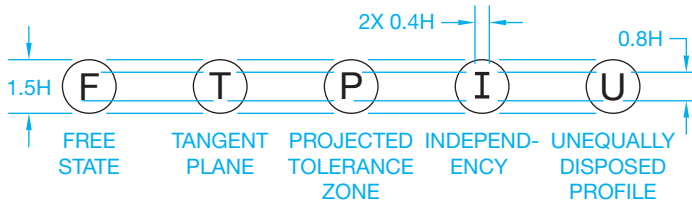
H = LETTER HEIGHT  
**SYMBOL SPECIFICATIONS**



**ORDER OF ELEMENTS**

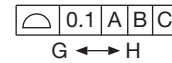
© Cengage Learning 2012

**FIGURE 13.41** A feature control frame showing the order of elements.



H = LETTER HEIGHT

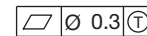
**SYMBOL SPECIFICATIONS**



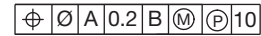
**BETWEEN SYMBOL APPLICATION**



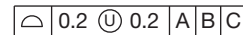
**MATERIAL CONDITION MODIFIER AND FREE STATE SYMBOL APPLICATION**



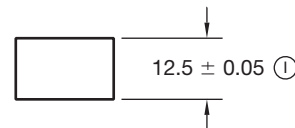
**TANGENT PLANE SYMBOL APPLICATION**



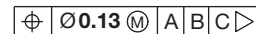
**MATERIAL CONDITION MODIFIER AND PROJECTED TOLERANCE ZONE SYMBOL APPLICATION**



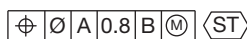
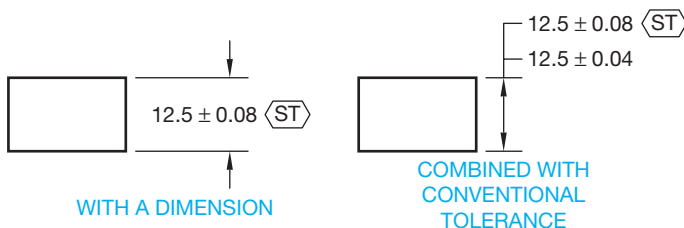
**UNEQUALLY DISPOSED TOLERANCE SYMBOL APPLICATION**



**INDEPENDENCY SYMBOL APPLICATION**



**DATUM TRANSLATION SYMBOL APPLICATION**



**WITH THE FEATURE CONTROL FRAME**

**STATISTICAL TOLERANCING APPLICATIONS**

**FIGURE 13.42** Additional geometric dimensioning and tolerancing symbols.

© Cengage Learning 2012

## FORM GEOMETRIC TOLERANCES

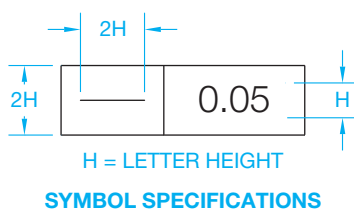
This section covers the concepts and techniques of dimensioning and tolerancing to control the form of geometric shapes. **Form tolerances** specify a zone in which the dimensioned feature, the feature's line elements, the feature's derived median plane, or the feature's derived median line must be controlled. Form tolerances are applied to single features or elements of single features. Therefore, form tolerances are not related to datums. Form tolerances control: straightness, flatness, circularity, and cylindricity. Form geometric tolerances can be applied to datum features. This is specified on the drawing by attaching the datum feature symbol directly to the form control or to the leader associated with the control (see Figure 13.6). Note that this does not relate the geometric tolerance to a datum.

### Straightness

**Straightness** is a condition where an element of a surface or an axis is in a straight line. Straightness is a form tolerance. The straightness tolerance specifies a zone within which the required surface element or axis must lie. Figure 13.43 shows a detailed example of the straightness geometric characteristic symbol used in a feature control frame.

Surface straightness tolerance is represented by connecting the feature control frame to the surface with a leader or by connecting the feature control frame to an extension line in the view where the surface to be controlled is shown as an edge. Placement of the feature control frame on the extension line is not normally recommended for cylindrical objects but is typically used on planar surfaces. The feature cannot exceed the MMC envelope and perfect form must be maintained if the actual size is produced at MMC. Otherwise, RFS applies and the geometric tolerance remains the same at any produced size. Figure 13.31 shows a drawing and an exaggerated representation of what happens when a surface straightness tolerance is applied. The chart in Figure 13.31 shows the maximum out-of-straightness tolerance at several possible produced sizes with RFS implied. The straightness tolerance must be less than the size tolerance.

Axis straightness is specified on a drawing by placing the feature control frame below the diameter dimension and placing a diameter symbol in front of the geometric tolerance to specify a cylindrical tolerance zone as shown in Figure 13.32. Notice in the chart in Figure 13.32 that RFS is assumed, and this application allows a violation of perfect form at MMC.



© Cengage Learning 2012

**FIGURE 13.43** A feature control frame with the straightness geometric characteristic symbol.

Axis straightness can also be specified on an MMC basis by placing the MMC material condition symbol after the geometric tolerance. The specified geometric tolerance is then held at MMC and allowed to increase as the actual size departs from MMC. The geometric tolerance is at MMC as shown in Figure 13.33. In this case, the straightness tolerance can be greater than the size tolerance, but normally the straightness tolerance is less than the size tolerance. In this application, the acceptance boundary is the maximum size plus the allowable out-of-straightness tolerance. The acceptance boundary can be used as a functional gage to verify the part. The local size is also verified so the part does not exceed the size tolerance and the gage can be used to verify the straightness.

### Unit Straightness

Straightness per unit of measure can be applied to a part or feature together with a straightness specification over the total length. This can be done as a means of preventing an abrupt surface variation within a relatively short length of the feature. The specified geometric tolerance over the total length is greater than the unit tolerance and is normally given to keep the unit tolerance from getting out of control when applied to the length of the feature. The per unit specification can be given as a tolerance per inch or per 25 millimeters of length. When this technique is used, the feature control frame is doubled in height and split so the tolerance over the total length is specified in the top half and the per unit control placed in the bottom half.

### Straightness of Noncylindrical Features

Straightness can also be applied on an RFS or MMC basis to noncylindrical features of size. When this is done, the associated median plane must lie within two parallel planes separated by a distance equal to the specified geometric tolerance zone. The feature control frame can be attached to the view where the surface appears as a line by using a leader or an extension line. In this situation, the diameter symbol is not placed in front of the geometric tolerance.

### Straightness of a Flat Surface

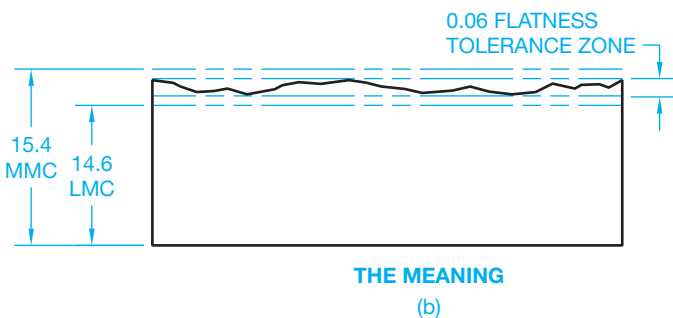
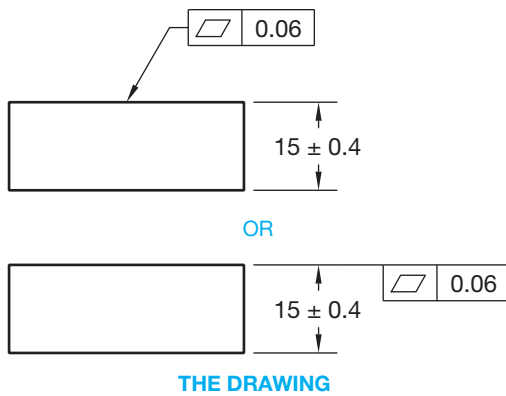
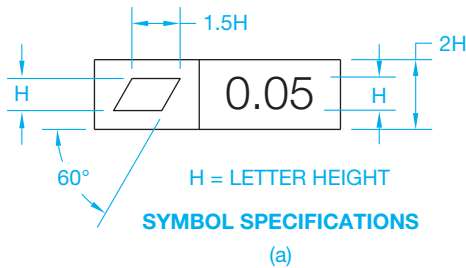
Straightness can also be applied to a flat surface. When this is done, the straightness geometric tolerance controls single line elements on the surface in one or two directions. The direction of the tolerance zone is determined by the placement of the feature control frame. For example, the tolerance zone is linear when the feature control frame is connected to the view where the length is shown.

### Straightness of a Limited Length

A straightness geometric tolerance can be applied to a portion of a long part by placing a chain line next to the view at the desired straightness length. The length of the chain line is dimensioned, and the feature control frame is connected to the chain line with a leader. This can be applied to a cylindrical part or a flat part.

## Flatness

Perfect flatness is the condition of a surface where all of the elements are in one plane. **Flatness** is a form tolerance. A flatness tolerance zone establishes the distance between two parallel planes within which the surface must lie. Figure 13.44a shows a detailed example of the flatness geometric characteristic symbol used in a feature control frame. When a flatness geometric tolerance is specified, the feature control frame is connected by a leader or an extension line in the view where the surface appears as a line (see Figure 13.44b). All of the points of the surface must be within the limits of the specified tolerance zone. The smaller the tolerance zone, the flatter the surface. The flatness tolerance must be less than the size tolerance when the surface is associated with a size tolerance. Flatness does not reference a datum and when applied to a surface is always considered regardless of feature size.



**FIGURE 13.44** (a) A feature control frame with the flatness geometric characteristic symbol. (b) The flatness geometric tolerance applied to a drawing. © Cengage Learning 2012

## Flatness Applied to a Size Dimension

A flatness geometric tolerance can be applied to a size dimension by placing the feature control frame under the dimension of the feature to be controlled. In this application, the derived median plane of the feature must lie within two parallel planes that are spaced equal to the specified flatness geometric tolerance. A flatness geometric tolerance specified to a size dimension can be applied RFS or MMC.

## Specific Area Flatness

It can be necessary to provide a flatness callout for only a specific area of a surface. This procedure is known as **specific area flatness**. Specific area flatness can be used when a large cast surface must be flat in a relatively small area. Rather than an expensive operation of machining the entire surface, it is possible to finish only the required area. When specific area flatness is used, the specific area is outlined with phantom lines and section lines are placed within the area. The specific area is then located, from datums, with basic or  $\pm$  dimensions. The feature control frame is connected to the area with a leader line.

## Unit Flatness

**Unit flatness** can be specified when it is desirable to control the flatness of a given surface area as a means of controlling an abrupt surface variation within a small area of the feature. The unit flatness specification can be used alone or in combination with a total tolerance. Most applications use unit flatness in combination with a total tolerance over the entire surface, so the unit callout is not allowed to get out of control. When this is done, the height of the feature control frame is doubled with the total tolerance placed in the top half and the unit tolerance plus the size of the unit area placed in the bottom half. The unit tolerance must be smaller than the total tolerance. Unit flatness can be specified using a square, rectangular, or circular unit area.

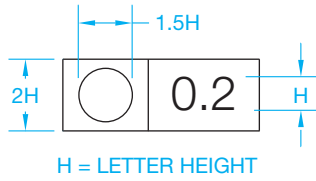
## Circularity

**Circularity** is characterized by any given cross section taken perpendicular to the axis of a cylinder or cone, or through the common center of a sphere. Circularity is a form tolerance. The circularity geometric tolerance is formed by two concentric circles within which the actual surface must lie. Circularity is established from the periphery or circumference of a shaft or the inside diameter of a hole. Circularity is not referenced to a datum and is always regardless of feature size. The circularity geometric tolerance must be less than the size tolerance. Figure 13.45a shows a detailed example of the circularity geometric characteristic symbol used in a feature control frame. The tolerance applies to only one sectional element at a time. When a circularity geometric tolerance is used, the feature control frame is connected with a leader to the view where the feature appears as a circle or in the longitudinal view. Examples showing circularity of a cylinder and a cone are shown in Figure 13.45b. Circularity is always specified as regardless of feature size and no datum reference is used.

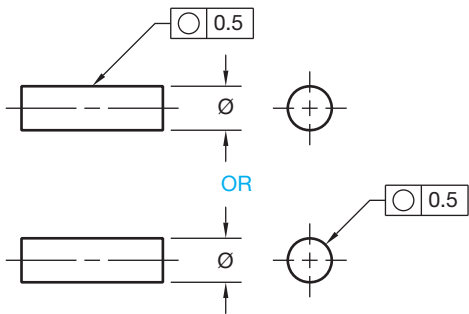


### Circularity Tolerance for a Sphere

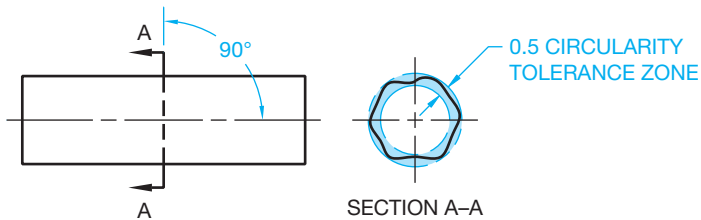
The circularity geometric tolerance can also be applied to a sphere. When this is done, the circularity geometric tolerance is established by two concentric circles created by a plane passing



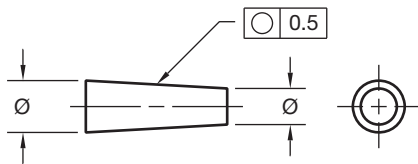
H = LETTER HEIGHT  
**SYMBOL SPECIFICATIONS**  
 (a)



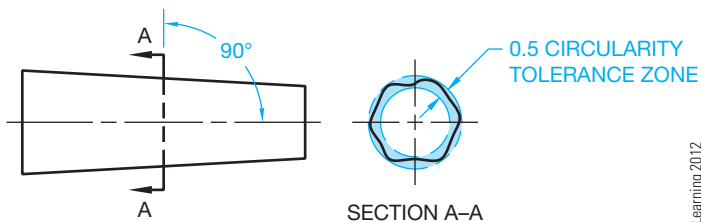
**THE DRAWING**



**THE MEANING**  
**CIRCULARITY OF A CYLINDRICAL FEATURE**



**THE DRAWING**



**THE MEANING**  
**CIRCULARITY OF A CONICAL FEATURE**

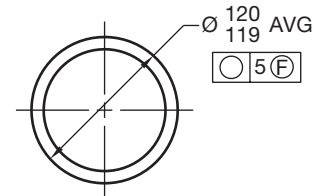
(b)

**FIGURE 13.45** (a) A feature control frame with the circularity geometric characteristic symbol. (b) Applying the circularity geometric tolerance to cylindrical and conical features.

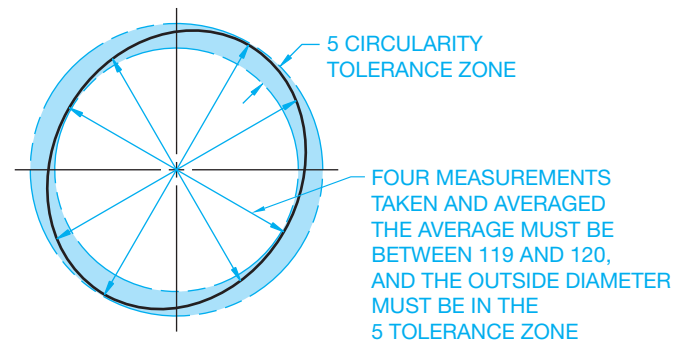
through the center of the sphere. All points on the surface must lie within the circularity tolerance zone.

### Free State Variation Applied to Circularity

The circularity tolerance must be less than the size tolerance, except for parts subject to **free state variation**. Free state variation is the distortion of a part after removal of forces applied during manufacture. Distortion can happen to thin wall parts where the weight and flexibility of the part are affected by internal stresses applied during fabrication. These types of parts are referred to as *nonrigid*. The part may have to meet the tolerance specifications while in free state or it may be necessary to hold features in a simulated mating part to verify dimensions. The free state symbol, shown in Figure 13.40, is placed in the feature control frame after the geometric tolerance and material condition symbol if MMC or LMC is required. It can be necessary to specify circularity of a nonrigid part based on an average size diameter to help make sure the desired diameter can be held during assembly. When this is necessary, the abbreviation **AVG** is placed after the size dimension as shown in Figure 13.46. The average diameter is the average of several measurements across a circular or cylindrical feature. Normally, at least four measurements or enough measurements are taken to ensure the establishment of an average diameter. The



**THE DRAWING**  
**NONRIGID PART (O-RING)**



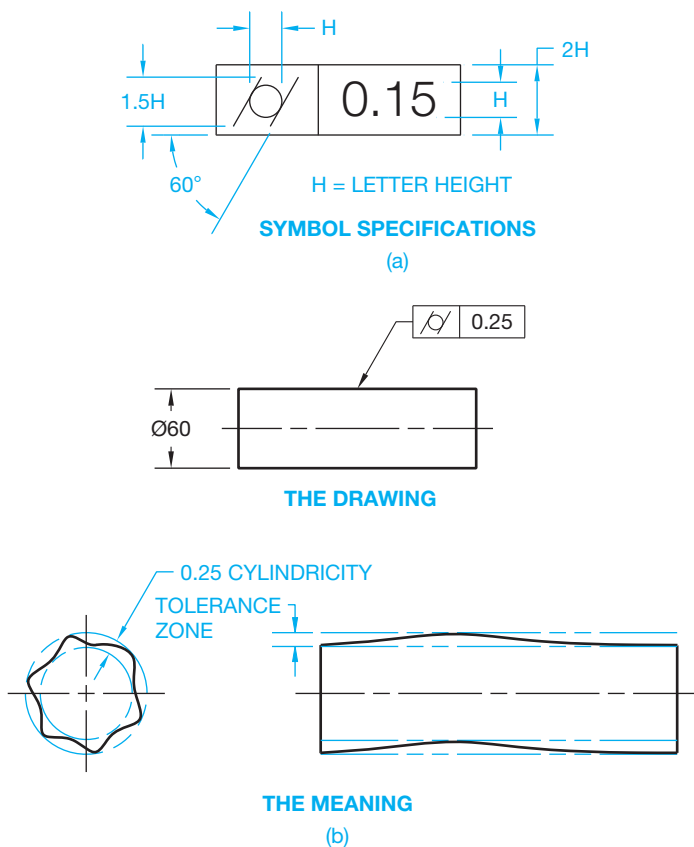
**THE MEANING**

**FIGURE 13.46** When used, the free state symbol is placed in the feature control frame after the geometric tolerance and any material condition symbol. No material condition symbol is used in this case. Specifying average size diameter of nonrigid parts using the **AVG** abbreviation after the size dimension.

circularity tolerance is larger than the size tolerance, because the average of the diameter measurements is established within the boundaries of the circularity tolerance. In Figure 13.46, free state circularity is applied on a drawing of an O-ring. This is a nonrigid part. For this application, at least four measurements are taken and averaged. The average must be between the size limits, and the outside diameter must be within the specified circularity geometric tolerance.

## Cylindricity

**Cylindricity** is identified by a tolerance zone that establishes two perfectly concentric cylinders within which the actual surface must lie. Cylindricity is a form tolerance and is not referenced to a datum. Figure 13.47a shows a detailed example of the cylindricity geometric characteristic symbol used in a feature control frame. The cylindricity geometric tolerance must be less than the size tolerance. Cylindricity is always considered regardless of feature size. The feature control frame showing the cylindricity tolerance specification is connected by a leader to either the circular or the longitudinal view, as shown in Figure 13.47b. Cylindricity is a composite control of form that includes circularity, straightness, and taper of a cylindrical feature. Cylindricity can be characterized as a blanket tolerance that covers the entire feature.



**FIGURE 13.47** (a) A feature control frame with the cylindricity geometric characteristic symbol. (b) An application of the cylindricity geometric tolerance. © Cengage Learning 2012

## ORIENTATION GEOMETRIC TOLERANCES

This section covers the concepts and techniques of dimensioning and tolerancing to control the orientation of geometric features. **Orientation geometric tolerances** control: parallelism, perpendicularity, and angularity.

When size tolerances provided in conventional dimensioning do not provide enough control for the functional design and interchangeability of a product, then form or profile tolerances or both form and profile should be specified. Size limits control a degree of form and parallelism. Locational tolerances control a certain amount of orientation. Therefore, the need for further form and orientation control should be evaluated before specifying geometric tolerances of form and orientation. When controlling orientation tolerances, the feature is related to one or more datum features. Relation to more than one datum should be considered if required to stabilize the tolerance zone in more than one direction. Parallelism, perpendicularity, and angularity tolerances control flatness in addition to their intended orientation control. Orientation tolerances are total. This means that all elements of the related surface or axis fall within the specified tolerance zone. When less-demanding requirements controlling only individual line elements of a surface meet the design goal, a note such as EACH ELEMENT or EACH RADIAL ELEMENT should be shown below the associated feature control frame. This application permits individual line elements of a surface, rather than the total surface, to be controlled in relation to a datum. When applied to a plane surface, an orientation geometric tolerance also controls flatness to the extent of the orientation tolerance. Orientation tolerances imply RFS. Therefore, MMC or LMC must be specified if any application other than RFS is intended.

### Parallelism

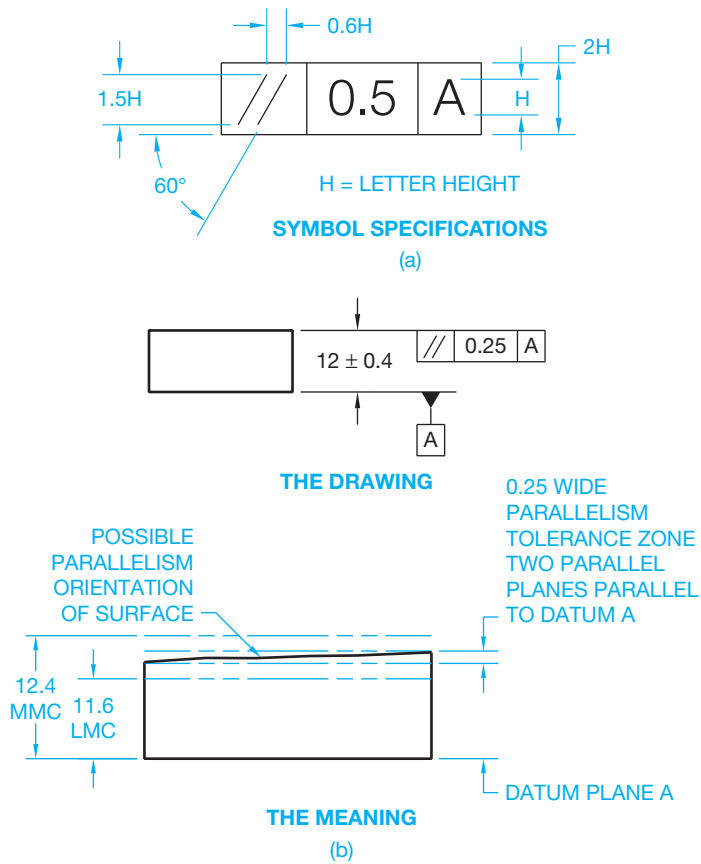
**Parallelism** is the condition of a surface or center plane equidistant from a datum plane or axis. Parallelism is also the condition of an axis equidistant along its length from one or more datum planes or a datum axis. A parallelism geometric tolerance is established by two parallel planes or cylindrical zones that are parallel to a datum plane, and between which the surface or axis of the feature must lie. The parallelism geometric characteristic symbol and associated feature control frame are detailed in Figure 13.48a.

### Surface Parallelism

When a surface is to be parallel to a datum, the feature control frame is either connected by a leader to the surface or to an extension line from the surface. The actual surface must be within the parallelism tolerance zone that is established by two planes parallel to the datum. The parallelism tolerance zone must be within the specified size limits (see Figure 13.48b).

### Tangent Plane

Geometric tolerance zones are total. This means that all elements of the related surface or axis must fall within this zone

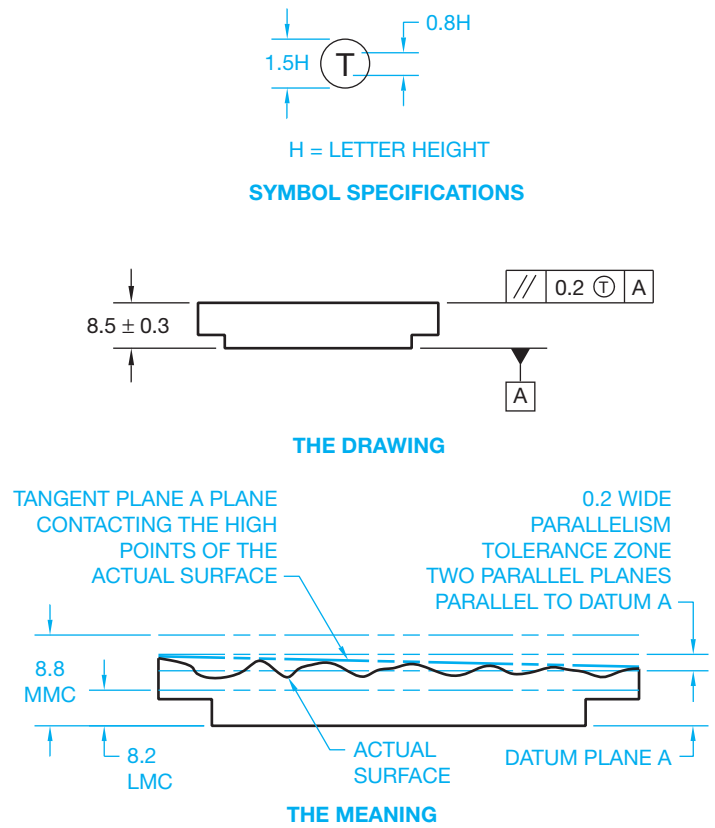


**FIGURE 13.48** (a) A feature control frame with the parallelism geometric characteristic symbol and datum reference. (b) An application of the parallelism geometric tolerance. © Cengage Learning 2012

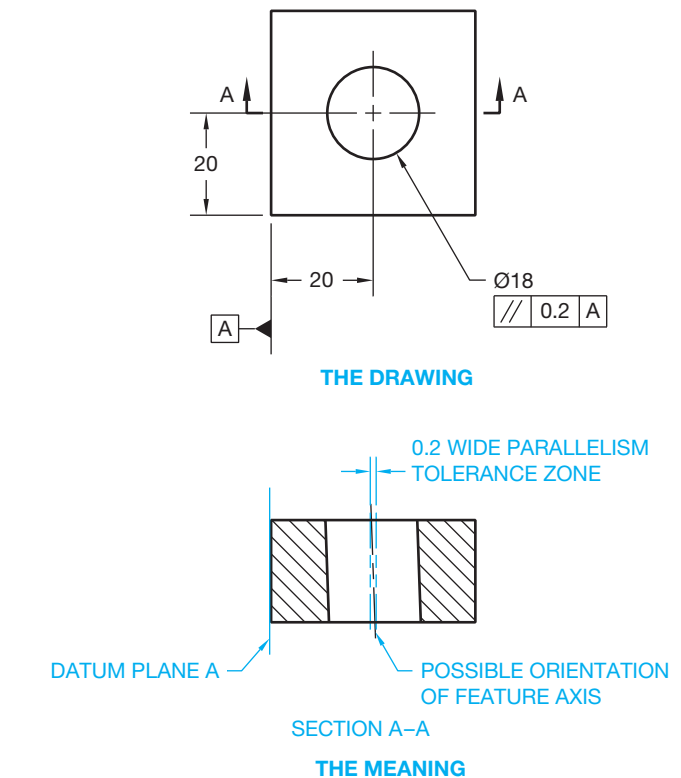
unless the note EACH ELEMENT or EACH RADIAL ELEMENT is placed below the feature control frame, as discussed previously. The total geometric tolerance zone also means that the surface elements or axis can be anywhere within the geometric tolerance zone. An additional requirement can be applied to the surface within the geometric tolerance zone by using a **tangent plane** specification. A tangent plane is a plane that contacts the high points of the specified feature. When a tangent plane control is required, the tangent plane symbol follows the geometric tolerance in the feature control frame. A tangent plane application is used with a parallelism geometric tolerance in Figure 13.49. In this application, the actual surface can be outside the parallelism geometric tolerance zone, but the tangent plane must be within the parallelism geometric tolerance zone.

### Axis Parallelism

A parallelism tolerance can be established for a feature axis by two parallel planes that are parallel to a datum plane and between which the axis must lie. For example, the axis of a hole can be specified within a tolerance zone that is parallel to a given datum. This parallelism tolerance zone must also be within the specified locational tolerance. The feature control frame is placed with the diameter dimension as shown in Figure 13.50, and RFS is assumed.

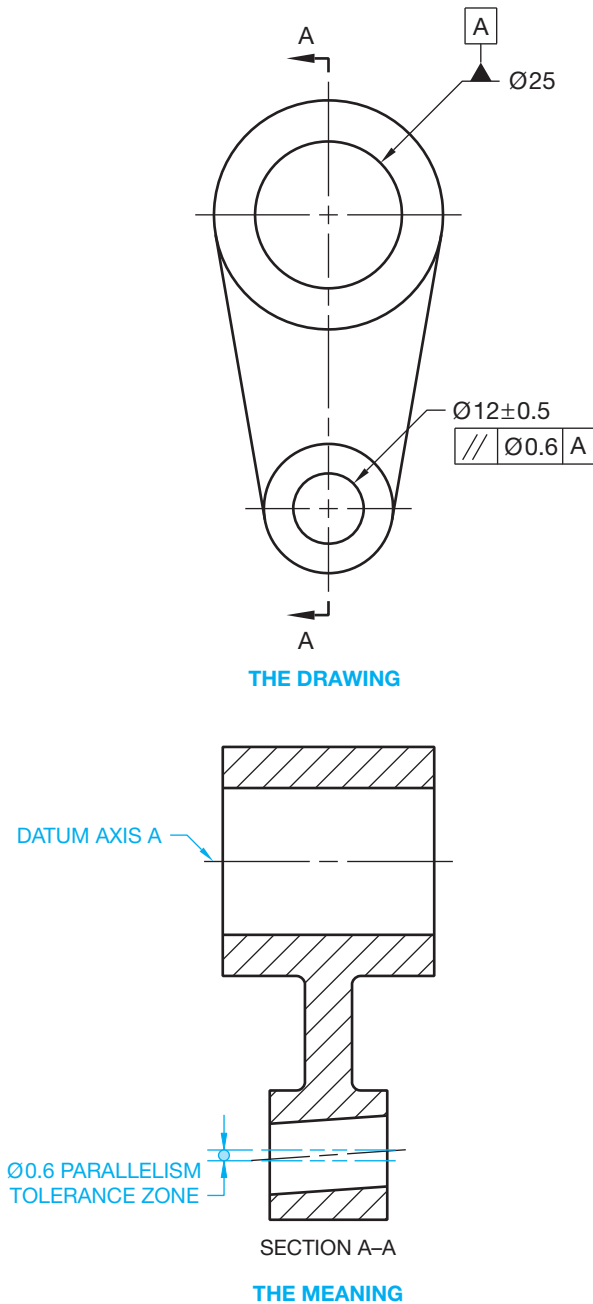


**FIGURE 13.49** Using the tangent plane application. © Cengage Learning 2012



**FIGURE 13.50** Specifying parallelism of an axis to a datum plane.

Parallelism can also be applied to the axes of two or more features when a parallel relationship between the features is desired. The axis of a feature must lie within a cylindrical tolerance zone that is parallel to a given datum axis, establishing a diameter tolerance zone. RFS is assumed unless MMC or LMC is applied. Figure 13.51 shows an RFS application.



**FIGURE 13.51** Specifying parallelism of an axis to a datum axis. RFS is assumed in this example. The MMC or LMC material condition symbol must be placed after the geometric tolerance for these to apply.

### Parallelism of Line Elements

Orientation tolerances—such as parallelism, perpendicularity, angularity, and, in some cases, profile—are implied to be total where an axis or all elements of a surface must fall within the specified tolerance zone. Where it is desirable to control only individual line elements, rather than the entire surface, the note EACH ELEMENT is placed below the feature control frame. This allows control of individual elements of the surface independently related to the datum and does not control the entire surface within the zone. Note that the EACH ELEMENT specification only controls elements in a plane parallel to the view in which the tolerance is given.

### Parallelism of Radial Elements

A **radial element** is a line element on the contour of a radial surface. When control of parallelism for individual line elements on a radial surface is desired, the note EACH RADIAL ELEMENT is placed under the feature control frame. This allows control of individual elements of the surface independently related to the datum.

## Perpendicularity

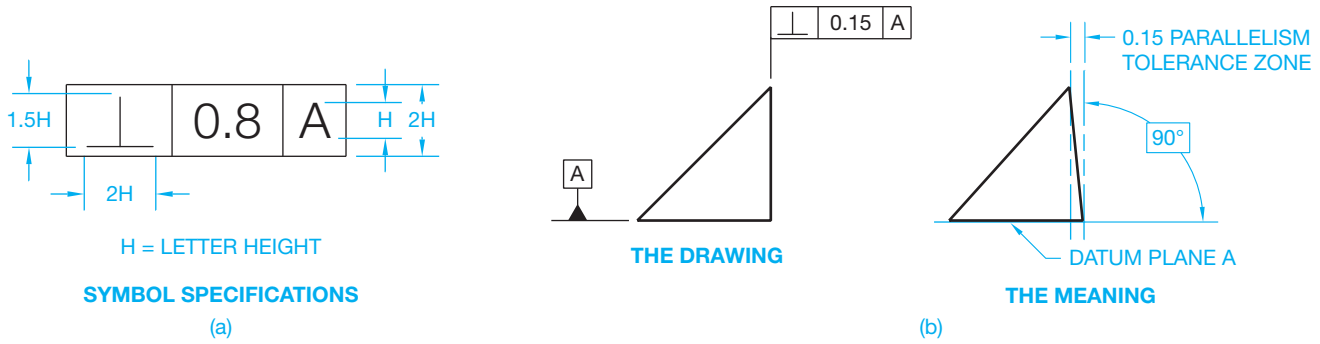
**Perpendicularity** is the condition of a surface, center plane, or axis at a right angle (90°) to a datum plane or axis. A perpendicularity tolerance is established by a specified geometric tolerance zone made up of two parallel planes or cylindrical zones that are a basic 90° to a given datum plane or axis, and within which the actual surface or axis must lie. The perpendicularity geometric characteristic symbol and associated feature control frame are detailed in Figure 13.52a. When a surface is to be perpendicular to a datum, the feature control frame can be connected to the surface with a leader or from an extension line, as shown in Figure 13.52b. The actual surface is oriented between two parallel planes that are perfectly 90° to the datum plane. Perpendicularity is always controlled regardless of feature size and a datum reference is required.

You can also hold a surface perpendicular to two datum planes. When this is done, the surface must lie between two parallel planes that are perpendicular to two datum planes. Both datums are referenced in the feature control frame.

### Perpendicularity of an Axis

Perpendicularity can be a tolerance zone made up of two parallel planes perpendicular to a datum plane or axis within which the axis of the feature must lie. In this application, the datum feature is established and the feature control frame is placed below the diameter dimension controlling perpendicularity. This geometric tolerance only applies in the view where the dimension is shown. RFS is implied unless MMC or LMC is specified in the feature control frame after the geometric tolerance. For example, the 0.2 wide perpendicularity tolerance zone in Figure 13.53 controls the orientation as shown in section A-A, but not in the direction represented by section B-B. There is

© Cengage Learning 2012

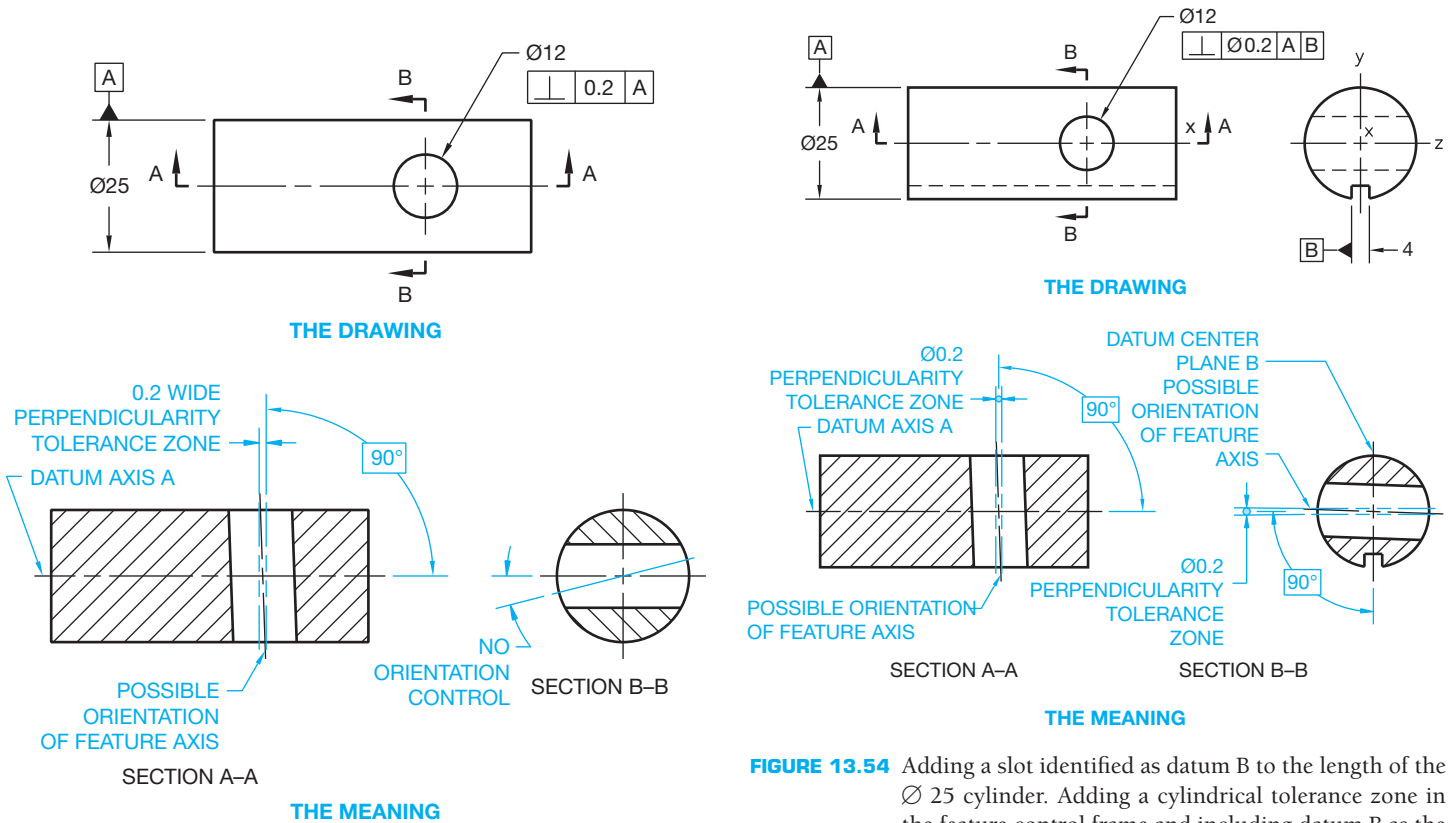


**FIGURE 13.52** (a) A feature control frame with the perpendicularity geometric characteristic symbol and datum reference. (b) An application of the perpendicularity geometric tolerance to one datum reference.

nothing to keep the cylindrical tolerance zone from rotating around the axis of datum A if the feature is viewed from the end of the datum cylinder. A cylindrical perpendicularity tolerance zone can be applied by placing a diameter symbol in front of the geometric tolerance in the feature control frame. In this application, the axis of the hole is contained within a cylindrical tolerance zone that is perpendicular to the axis of datum A.

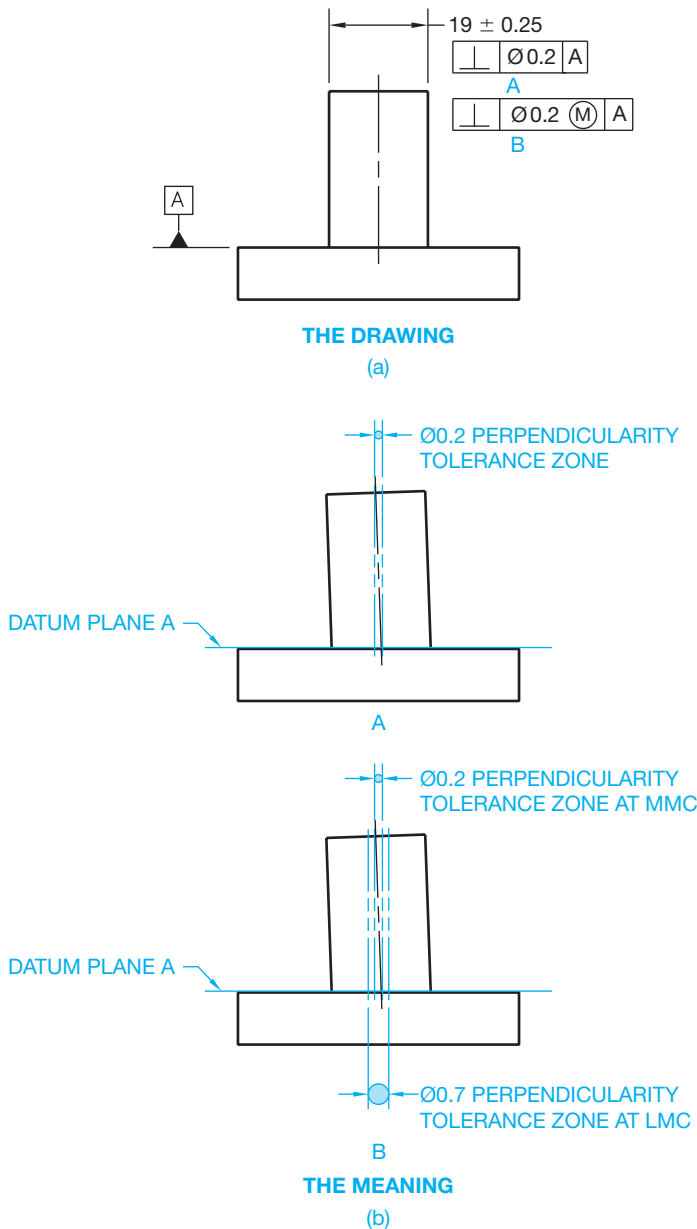
In Figure 13.53, the  $\varnothing 25$  cylindrical feature is the datum reference feature A. This is the axis that establishes the resistance for the degrees of freedom of the part. When looking at the end of the  $\varnothing 25$  cylinder, the cylinder resists movement in the Y- and Z-directions and resists rotation about the Y- and Z-axes, but

there is no resistance about the X-axis. In this case, the effect of applying a geometric tolerance zone to the  $\varnothing 12$  hole accomplishes nothing in relation to controlling the degrees of freedom of the part. The desired effect is to establish resistance for the degrees of freedom by designing a slot that runs the length of the  $\varnothing 25$  cylinder, at the circumference, and identify the slot as datum B. Then, adding a cylindrical tolerance zone in the feature control frame and including datum B as the secondary datum establishes the resistance for the degrees of freedom (see



**FIGURE 13.53** Specifying perpendicularity of an axis to a datum axis.  
© Cengage Learning 2012

**FIGURE 13.54** Adding a slot identified as datum B to the length of the  $\varnothing 25$  cylinder. Adding a cylindrical tolerance zone in the feature control frame and including datum B as the secondary datum establishes the desired resistance for the degrees of freedom of the part. © Cengage Learning 2012



**FIGURE 13.55** Specifying the perpendicularity of an axis to a datum plane. (a) Regardless of feature size application. (b) MMC application. © Cengage Learning 2012

Figure 13.54). The  $\text{Ø}25$  cylinder resists movement in the Y- and Z-directions and resists rotation about the Y- and Z-axes, and there is resistance about the X-axis when looking into the end of the cylinder.

Another application that can require a perpendicularity specification is a cylindrical feature such as a pin or stud. In this situation, the feature axis is within a cylindrical tolerance zone that is perpendicular to a datum plane. The feature control frame is attached to the diameter dimension and a diameter symbol precedes the geometric tolerance to specify a cylindrical tolerance zone as shown in Figure 13.55. Regardless of feature, size is implied as shown in Figure 13.55a. Figure 13.55b shows the use of MMC.

## Perpendicularity of a Center Plane

A symmetrical feature, such as a slot, can be specified as perpendicular to a datum plane. In this application, the feature center plane is held within two parallel planes that are perpendicular to a given datum plane. The center plane must also be within the specified locational tolerance.

## Perpendicularity of Line Elements

Single line elements of a surface, rather than the entire surface, can be perpendicular to a given datum. When any single line element of the object shall be held perpendicular to a datum, the note EACH ELEMENT is indicated below the feature control frame.

## Perpendicularity of Radial Elements

When control of perpendicularity for individual line elements on a radial surface is desired, the note EACH RADIAL ELEMENT is placed under the feature control frame. This allows control of individual elements of the surface independently related to the datum.

## Combining Parallelism and Perpendicularity

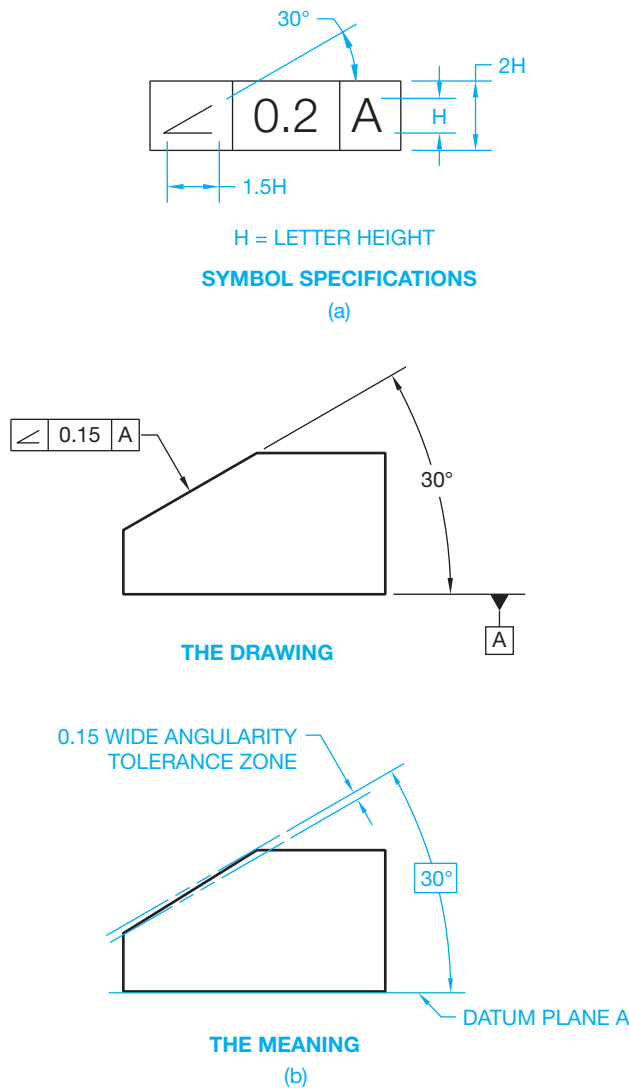
Parallelism and perpendicularity can be combined. This allows uniform parallelism and perpendicularity to related datums. The tolerance zones are often different, but they can be the same. This application uses a double feature control frame with one of the geometric characteristic symbols and related tolerance in the top and the other in the bottom. When the geometric tolerance zones are the same, they still remain in their own feature control frame compartments.

## Angularity

**Angularity** is the condition of a surface, center plane, or axis at any specified angle from a datum plane or axis. An angularity geometric tolerance zone is established by two parallel planes or cylindrical zones at any specified basic angle, other than  $90^\circ$ , to a datum plane, a pair of datum planes, or an axis. The angularity geometric characteristic symbol and associated feature control frame are detailed in Figure 13.56a. When applying an angularity geometric tolerance to a surface, the feature control frame is normally connected to the surface by a leader, but it can be attached to an extension line from the surface. The specified angle must be basic and dimensioned from the datum plane as shown in Figure 13.56b. RFS is implied unless otherwise specified.

## Angularity of an Axis

The axis of a hole or other cylindrical feature can be dimensioned with an angularity tolerance if the feature is at an angle other than  $90^\circ$  to a datum plane or axis. This specification establishes two parallel planes spaced equally on each side of the specified basic angle from a datum plane or axis between which



**FIGURE 13.56** (a) A feature control frame with the angularity geometric characteristic symbol and datum reference. (b) An application of the angularity geometric tolerance to a datum reference.

the axis of the feature must lie. This control applies only to the view in which the feature is specified. The feature control frame is shown below the feature diameter dimension to specify axis control. An auxiliary view of the hole should be provided giving true geometry of the location dimensions to the center of the hole. Secondary and tertiary datums can be considered for these location dimensions, which then allow you to control the axis at an angle to the primary datum and parallel to a secondary or tertiary datum. It is also possible to control the feature axis within a cylindrical angularity tolerance zone. To do this, a diameter symbol is placed in front of the geometric tolerance in the feature control frame. This indicates that the angularity tolerance zone is cylindrical. Location of the feature should still be placed in an auxiliary view, and secondary and tertiary datums considered for establishing these location dimensions as previously described.

### Angularity of a Center Plane and Single Element Control

An angularity geometric tolerance, just like parallelism and perpendicularity, can control the orientation of the center plane of a symmetrical feature, such as a slot or center plane. This angularity tolerance is formed by two parallel planes at a specified basic angle to a datum plane between which the center plane of the feature must lie. Angularity may also be controlled on a single line element or single radial element basis by placing the note EACH ELEMENT or EACH RADIAL ELEMENT below the feature control frame.

### Applying Zero Orientation Tolerance at MMC

Zero geometric tolerance at MMC can be applied when the geometric tolerance in the feature control frame is zero and the MMC material condition symbol is used. This means that at the MMC produced size, the feature must be perfect in orientation with respect to the specified datum. As the actual produced size departs from MMC, the geometric tolerance increases equal to the amount of departure. This is done to create a boundary of perfect form at MMC to control the relationship between features.

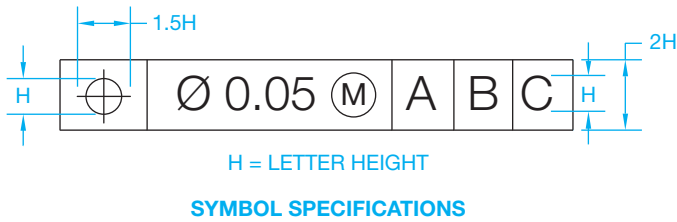
The idea behind using zero geometric tolerance at MMC is to allow more size tolerance. Zero orientation tolerance at MMC can be used for parallelism, perpendicularity, or angularity. Although the zero geometric tolerance at MMC method is easy and eliminates the use of a note, the note PERFECT ORIENTATION AT MMC REQUIRED FOR RELATED FEATURES can also appear on the drawing.

### Location Tolerancing

**Location tolerances** are used for the purpose of locating features from datums, or for establishing coaxiality or symmetry. Location tolerances include position, concentricity, and symmetry.

Positional tolerancing is used to define a zone in which the center, axis, or center plane of a feature of size is permitted to vary from **true position**. True position is the theoretically exact location of a feature. Basic dimensions are used with baseline or chain dimensioning systems to establish the true position from specified datum features and between interrelated features. Location tolerancing is specified by a positional, concentricity, or symmetry symbol, a tolerance, and appropriate datum references placed in a feature control frame. When positional tolerancing is used, the appropriate material condition and material boundary symbol must be specified after the tolerance and applicable datum reference in the feature control frame. Otherwise, RFS and RMB are assumed.

In comparison to conventional methods, the use of positional tolerancing concepts provides some of the greatest advantages to mass production. The conventional coordinate dimensioning system limits the actual location of features to a rectangular tolerance zone. Using positional tolerancing, the



**FIGURE 13.57** Placement of the positional geometric characteristic symbol and tolerance in a feature control frame.  
© Cengage Learning 2012

location tolerance zone changes to a cylindrical shape, thus increasing the possible location of the feature by about 54%. This improves the interchangeability of parts while increasing manufacturing flexibility and reducing the scrap rate of parts. The use of MMC applied to the positional tolerance allows the tolerance zone to increase in diameter as the feature size departs from MMC. This application also allows greater flexibility in the acceptance of mating parts. The positional geometric characteristic symbol is placed in the feature control frame as shown in Figure 13.57. The next compartment of the feature control frame contains the diameter symbol if a cylindrical tolerance zone is applied, followed by the specified positional tolerance and a material condition symbol if MMC or LMC is used. Additional compartments are used for datum reference.

When locating holes using positional tolerancing, the location dimensions must be basic. This can be accomplished by applying the basic dimension symbol to each of the basic dimensions or by specifying on the drawing or in a reference document the general note UNTOLERANCED DIMENSIONS LOCATING TRUE POSITION ARE BASIC. Use of the general note method should be avoided for most applications, because required basic dimension can be misinterpreted with other dimensions where general tolerances are applied from the title block.

Positional tolerances are often applied at MMC. However, either MMC or LMC must be indicated in the feature control frame to the right of the positional tolerance as applicable. Otherwise, RFS is assumed. Figure 13.58a shows a basic drawing using a position tolerance application. The true position centerline is perpendicular to the primary datum. The centerline of the hole can be anywhere within the diameter and length of the specified cylindrical positional tolerance zone at the MMC size of the hole. Figure 13.58b shows the axis of the hole at true position. Figure 13.58c shows the axis of the hole at the extreme side of the positional tolerance zone. This is referred to as **extreme positional variation**. Figure 13.58d shows the axis of the hole at an extreme angle inside the positional tolerance zone. This is referred to as **extreme attitude variation**. Figure 13.58e shows the position tolerance zone at LMC.

### Positional Tolerance at MMC

A positional tolerance at MMC means that the specified positional tolerance applies when the feature is manufactured at MMC. The axis of a hole must fall within a cylindrical

tolerance zone with an axis located at true position. The diameter of this cylindrical tolerance zone is equal to the specified positional tolerance when the hole is manufactured at MMC. The positional tolerance is then allowed to increase equal to the amount departure from MMC. The maximum amount of positional tolerance is when the feature is produced at LMC. When MMC is applied to a positional tolerance, the following formulas are used to calculate the positional tolerance at any produced size.

#### INTERNAL FEATURE

$$\text{Actual size} - \text{MMC} + \text{Specified positional tolerance} = \text{Applied positional tolerance}$$

#### EXTERNAL FEATURE

$$\text{MMC} - \text{Actual size} + \text{Specified positional tolerance} = \text{Applied positional tolerance}$$

### Introduction to Virtual Condition

Virtual condition is a boundary that takes into consideration the combined effect of feature size at MMC and geometric tolerance. Virtual condition establishes a working zone that is used to establish gage member sizes and the MMC size of mating parts or fasteners for mating parts. The virtual condition represents extreme conditions at MMC plus or minus the related geometric tolerance. This is used to determine clearance between mating parts. It is important to determine the virtual condition when designing mating parts. Virtual condition is calculated for situations involving internal or external features. When calculating the virtual condition of an internal feature, use the formula:

$$\text{MMC of feature} - \text{Related geometric tolerance} = \text{Virtual condition}$$

When calculating the virtual condition of an external feature, use the formula:

$$\text{MMC of feature} + \text{Related geometric tolerance} = \text{Virtual condition}$$

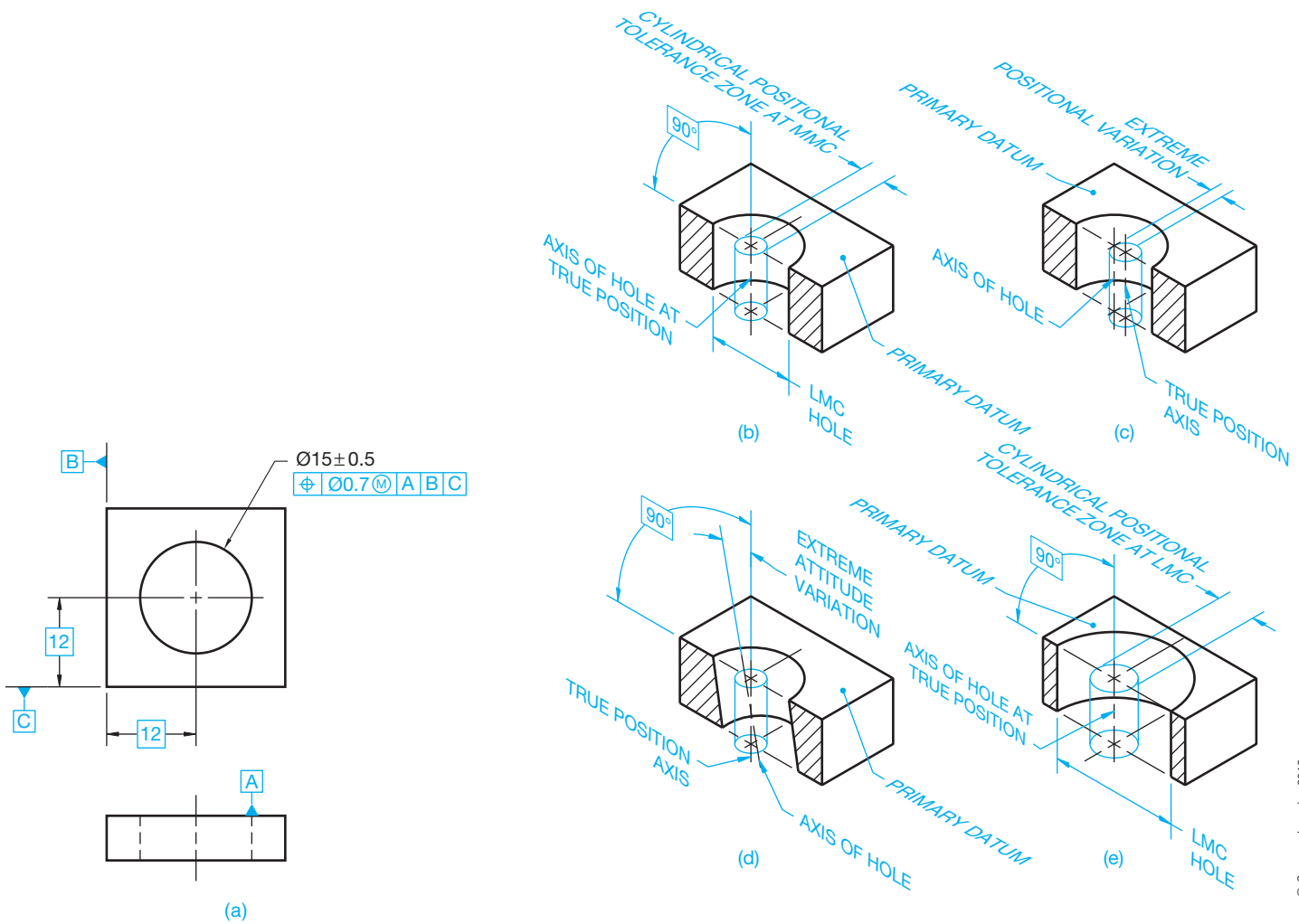
### Positional Tolerance Based on the Surface of a Hole

Positional tolerance applied at MMC can also be explained in regard to the surface of the hole rather than the hole axis. In this explanation, all elements of the hole surface must be outside a theoretical boundary located at true position, and the hole must be produced within the specified size limits as shown in Figure 13.59.

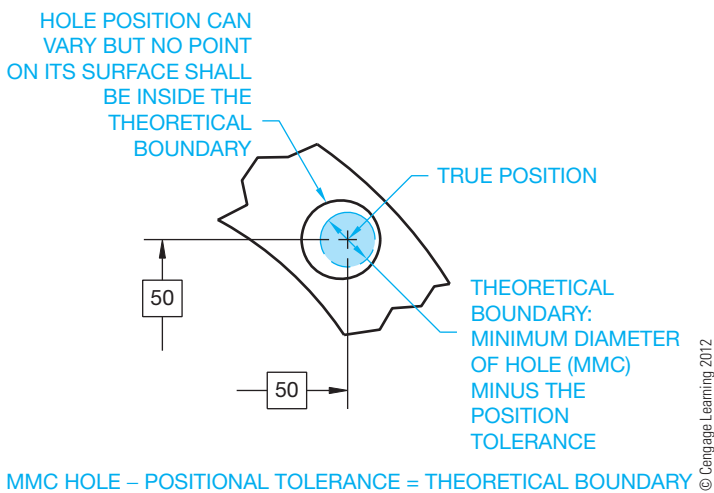
### Zero Positional Tolerancing at MMC

Zero geometric tolerancing can be applied to positional tolerances. The application of positional tolerance at MMC allows the positional tolerance zone to exceed the amount specified when the feature is produced at any actual size other than MMC. Zero positional tolerance can be specified when it is important that the tolerance is totally dependent on the actual size





**FIGURE 13.58** (a) A drawing with positional tolerancing, datum feature symbols, basic location dimensions, and feature control frame added. The hole axis in relation to the positional tolerance zone using the following conditions: (b) The axis of the hole at true position and the positional tolerance zone at MMC. (c) The axis of the hole at the extreme side of the positional tolerance zone referred to as *extreme positional variation*. The positional tolerance zone is at MMC. (d) The axis of the hole at an extreme angle inside the positional tolerance zone referred to as *extreme attitude variation*. The positional tolerance zone is at MMC. (e) The axis of the hole at true position and the positional tolerance zone at LMC. Notice the bonus positional tolerance provided when the hole is at LMC as compared with (b), where the positional tolerance is at MMC.



**FIGURE 13.59** The boundary for the surface of a hole at MMC.

of the feature. When this is done, the positional tolerance is zero when the feature is produced at MMC and must be located at true position. When the actual size of the feature departs from MMC, the positional tolerance is allowed to increase equal to the amount of departure. The total allowable variation in positional tolerance is at LMC, unless a maximum tolerance is specified. When zero positional tolerance at MMC is specified, the engineer normally applies the MMC of the hole at the absolute minimum required for insertion of a fastener when located at true position. The intent when using zero positional tolerance at MMC is to allow for a greater size tolerance.

### Positional Tolerance at RFS

RFS is assumed when no material condition symbol is placed after the positional tolerance in the feature control frame. RFS can be applied to the positional tolerance when it is desirable

to maintain the given positional tolerance at any produced size. The application of RFS requires closer controls of the features involved, because the size of the positional tolerance zone does not increase, as it does when MMC is used. The use of RMB is applied to a datum reference when MMB or LMB is not specified in the feature control frame following the datum reference.

**Positional Tolerance at LMC**

Positional tolerance at LMC is used to control the relationship of the feature surface and the true position of the largest hole size. The function of LMC is sometimes used to control minimum edge distance or minimum wall thickness. When the LMC material condition symbol is used in the feature control frame, the given positional tolerance is held at the LMC produced size. Then, as the produced size departs from LMC toward MMC, the positional tolerance increases equal to the amount of change from LMC. The maximum amount of positional tolerance is applied at the MMC produced size. When using the LMC control, perfect form is required at the LMC produced size. LMC specifications are limited to positional tolerances where the use of MMC does not give the desired control and RFS is too restrictive.

The minimum edge for the part is the same when the hole tolerance is at LMC or MMC and is calculated using these formulas:

$$\frac{\text{Location} - 1/2 \text{ LMC} - 1/2 \text{ geometric tolerance}}{\text{Minimum edge}}$$

$$\frac{\text{Location} - 1/2 \text{ MMC} - 1/2 \text{ geometric tolerance}}{\text{Minimum edge}}$$

When LMC is applied to a positional tolerance, the following formulas are used to calculate the positional tolerance at any produced size:

**INTERNAL FEATURE**

$$\text{LMC} - \text{Actual size} + \text{Specified positional tolerance} = \text{Applied positional tolerance}$$

**EXTERNAL FEATURE**

$$\text{Actual size} - \text{LMC} + \text{Specified positional tolerance} = \text{Applied positional tolerance}$$

**Locating Multiple Features**

Multiple features of an object can be dimensioned using positional tolerancing. The location of the features must be dimensioned from datums and between features using baseline or chain dimensioning related to rectangular or polar coordinates. The following guidelines apply when locating multiple features:

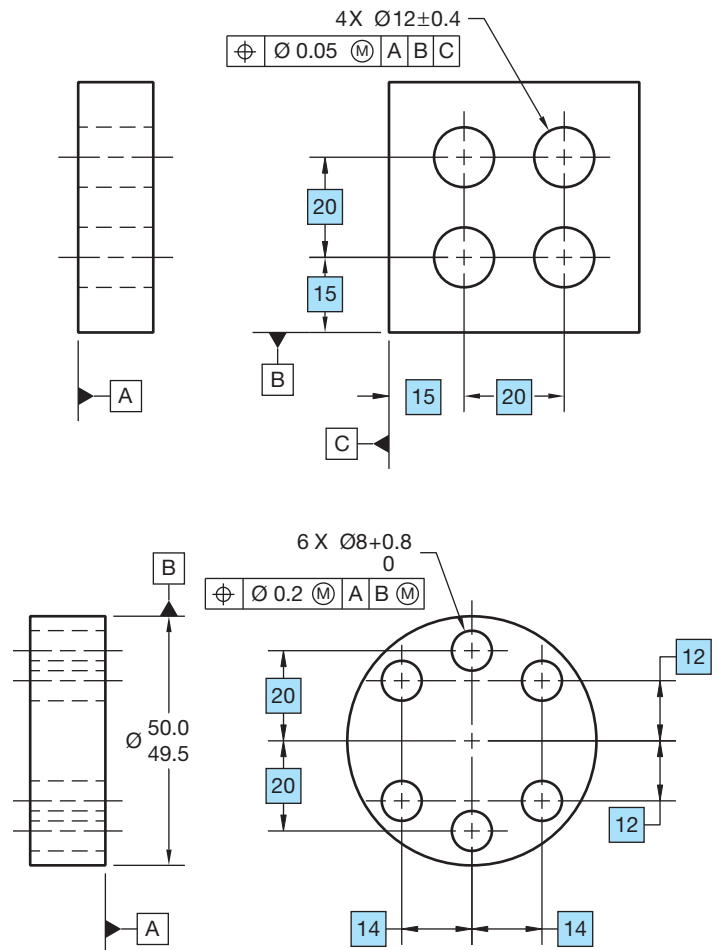
- The pattern of features is located collectively in relation to datum features that are not subject to size changes. The

actual centers of all features in the pattern must lie on, or be within, the specified positional tolerance zone when measured from the given datums.

- Multiple patterns of features are considered a single composite pattern if the related feature control frames have the same datums, in the same order of precedence, with the same material condition symbols.
- The pattern of features is located collectively in relation to datum features that are not subject to size changes. The actual centers of all features in the pattern must lie on, or be within, the specified positional tolerance zone when measured from the given datums.
- Multiple patterns of features are considered a single composite pattern if the related feature control frames have the same datums, in the same order of precedence, with the same material condition symbols.

Rectangular coordinate dimensioning is where linear dimensions are used to locate features from planes, centerlines, or center planes (see Figure 13.60).

Polar coordinate dimensioning is where angular dimensions are combined with other dimensions to locate features from planes, centerlines, or center planes. (See Figure 13.61.)



**FIGURE 13.60** Applying rectangular coordinate dimensioning. © Cengage Learning 2012

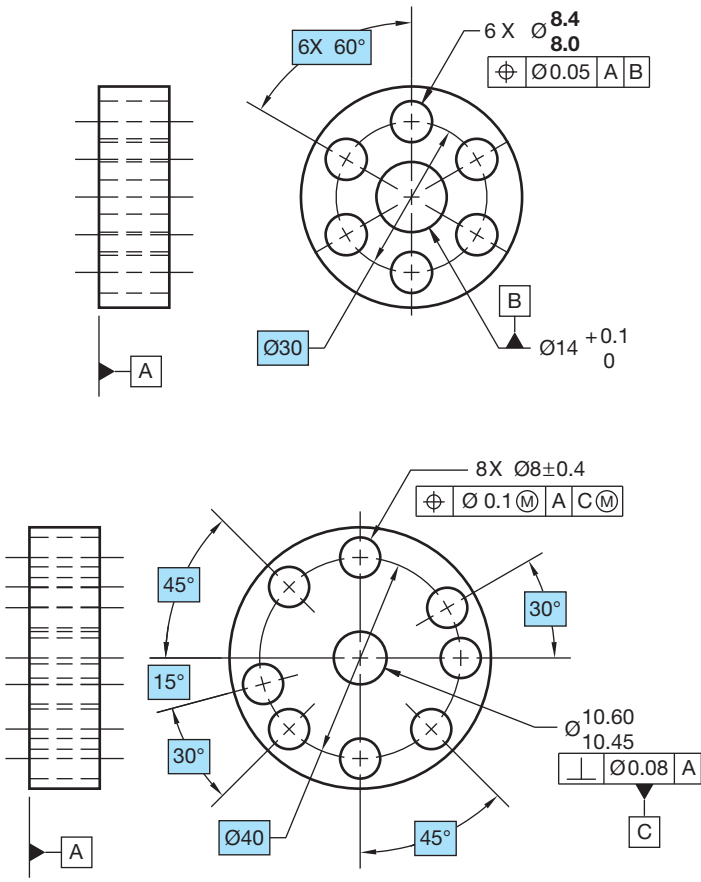


FIGURE 13.61 Applying polar coordinate dimensioning. © Cengage Learning 2012

**Locating a Single Composite Pattern**—A group of features is referred to as a **single composite pattern** when they are located relative to common datum features not subject to size tolerance, or to common datum features of size specified on an RFS basis. All of the location dimensions are basic from a common datum reference frame, as previously discussed. All of the holes can be checked together as shown in Figure 13.62.

**Locating Features in Patterns with Separate Requirements**—A pattern of features is located as a single composite pattern, as previously discussed, when there is no note given below the feature control frame that specifies otherwise. When multiple patterns of features exist and it is desired to treat the patterns separately with regard to the datum references, the note **SEP REQ**, meaning separate requirement, is placed below each feature control frame. This allows the patterns to be treated as separate patterns and to have their own datum reference frame. This can be done when features in one pattern are different in size or have different location requirements than the features in other patterns, as shown in Figure 13.63.

**Positional Tolerance Specified Individually**—When a multiple datum reference frame exists and features need to be positioned to different datums individually, then a note can be

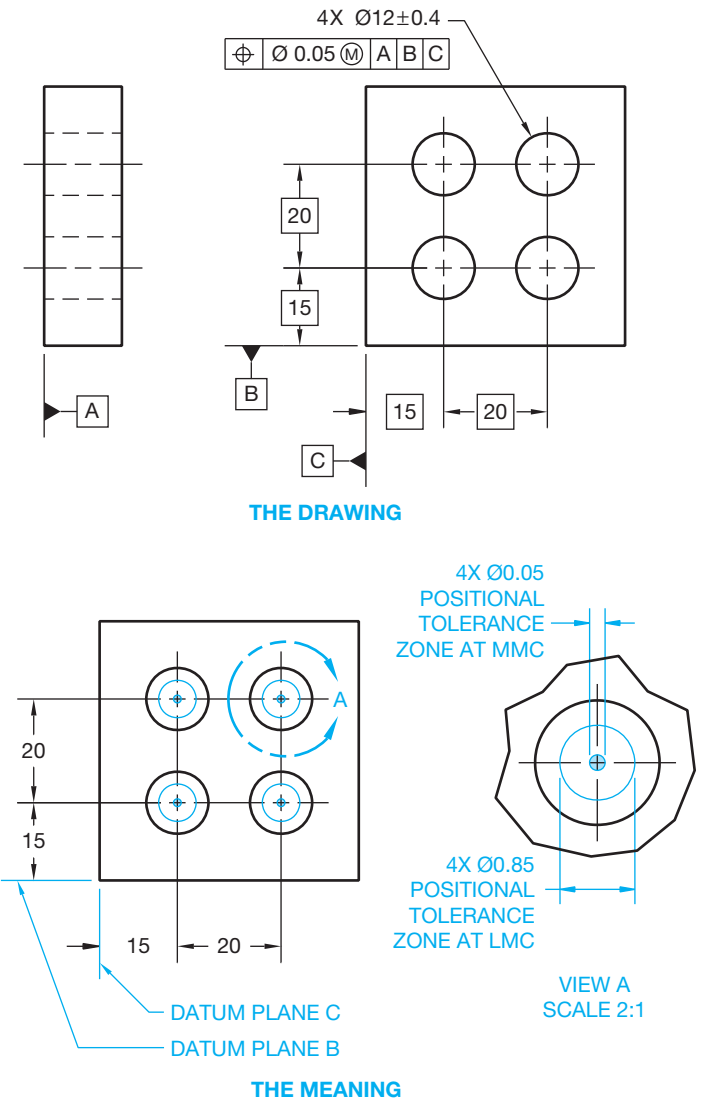


FIGURE 13.62 Locating a single composite pattern. © Cengage Learning 2012

placed next to the datum feature symbols and related position tolerance feature control frame identifying how many datum features and position tolerance specifications are to be considered individually. For example, if two separate datum features are identified with the same datum identification letter but need to be considered individually, then the note **2X INDIVIDUALLY** is placed next to the datum feature symbols and related position tolerance specification feature control frame. For example, consider a part with four holes at different angles with two holes on the right side of the part and two holes on the left side of the part. The holes on the right side need to be positioned to different datums than the holes on the left side. Instead of calling out two more datums, the current datums are used individually and the locations of two holes on each side are positioned to the two datums individually. Using this method, only two holes are checked for position at a time to different datums.

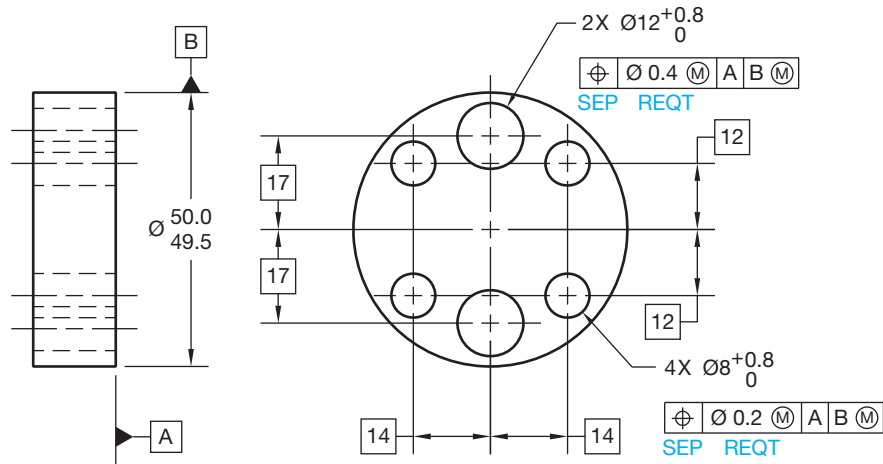


FIGURE 13.63 Locating features in a pattern with separate requirements.

© Cengage Learning 2012

**Composite Positional Tolerance—Composite positional tolerancing** is used when it is desirable to permit the location of a pattern of features to vary within a larger tolerance than the positional tolerance specified for each feature. For this application, the feature control frame is doubled in height and divided into two parts. Only one positional geometric characteristic symbol is used, and it is placed in one double height feature control frame compartment. The upper part of the feature control frame is the **pattern-locating control** and specifies the larger positional tolerance for the pattern of features as a group. The lower entry is called the **feature-relating control** and specifies the smaller positional tolerance for the individual features within the pattern. The pattern-locating control locates the pattern of features as a group to the specified datums. The pattern is located from the datums by basic dimensions. The feature-relating control is a feature-to-feature relationship. The features are related to each other with basic dimensions. The pattern-locating and feature-relating controls are inspected separately but are interrelated. The feature-relating control is free to shift and slant within the boundaries established by the pattern-locating control. When it is desired to control perpendicularity in the feature-relating control, only the primary datum is given in the bottom half of the feature control frame. If no datum reference is provided in the bottom half of the feature control frame, the feature-relating control is free to shift and slant within the boundaries established by the pattern-locating control. The tolerance zone of an individual feature can extend partly beyond the group zone, but the feature axis must fall within the confines of both zones. Also, all of the feature axes must lie within both zones, as shown in Figure 13.64.

The composite positional tolerance can also be applied with two datum references placed in the lower half of the feature control frame. When this is done, the feature-relating control must remain as a group that is perpendicular to the primary datum

and parallel to the secondary datum. The pattern-locating and feature-relating zones are parallel. This feature-relating orientation to the secondary datum is not required when only the primary datum reference is placed in the lower half of the feature control frame.

**Two Single-Segment Feature Control Frames**—The composite positional tolerance is specified by a feature control frame doubled in height with one position symbol shown in the first compartment. Also provided is a single datum reference given for orientation or a double datum reference given for orientation and alignment with respect to the feature-relating control. The **two single-segment feature control frame** is similar, except there are two position symbols, each displayed in a separate compartment, and a two-datum reference in the lower half of the feature control frame as shown in Figure 13.65. The top feature control frame is the pattern-locating control and works as previously described. The lower feature control frame is the feature-relating control where two datums control the orientation and the alignment with the pattern-locating control. This type of positional tolerance provides a tighter relationship of the holes within the pattern than the composite positional tolerance, because both the pattern-locating zones and the feature-relating zones must remain the same distance from the secondary datum (see Figure 13.65).

**Composite Positional Tolerancing Applied To Circular Patterns**—Composite positional tolerancing can be applied to circular patterns of features. In this application, the pattern-locating tolerance zones are located using a basic diameter and basic angle between features, and they are oriented to the specified datum reference frame. The feature-relating tolerance zones are held perpendicular to the primary datum, controlled as a group by the basic dimensions, and are partially or totally within the boundaries of the pattern-locating tolerance zones.

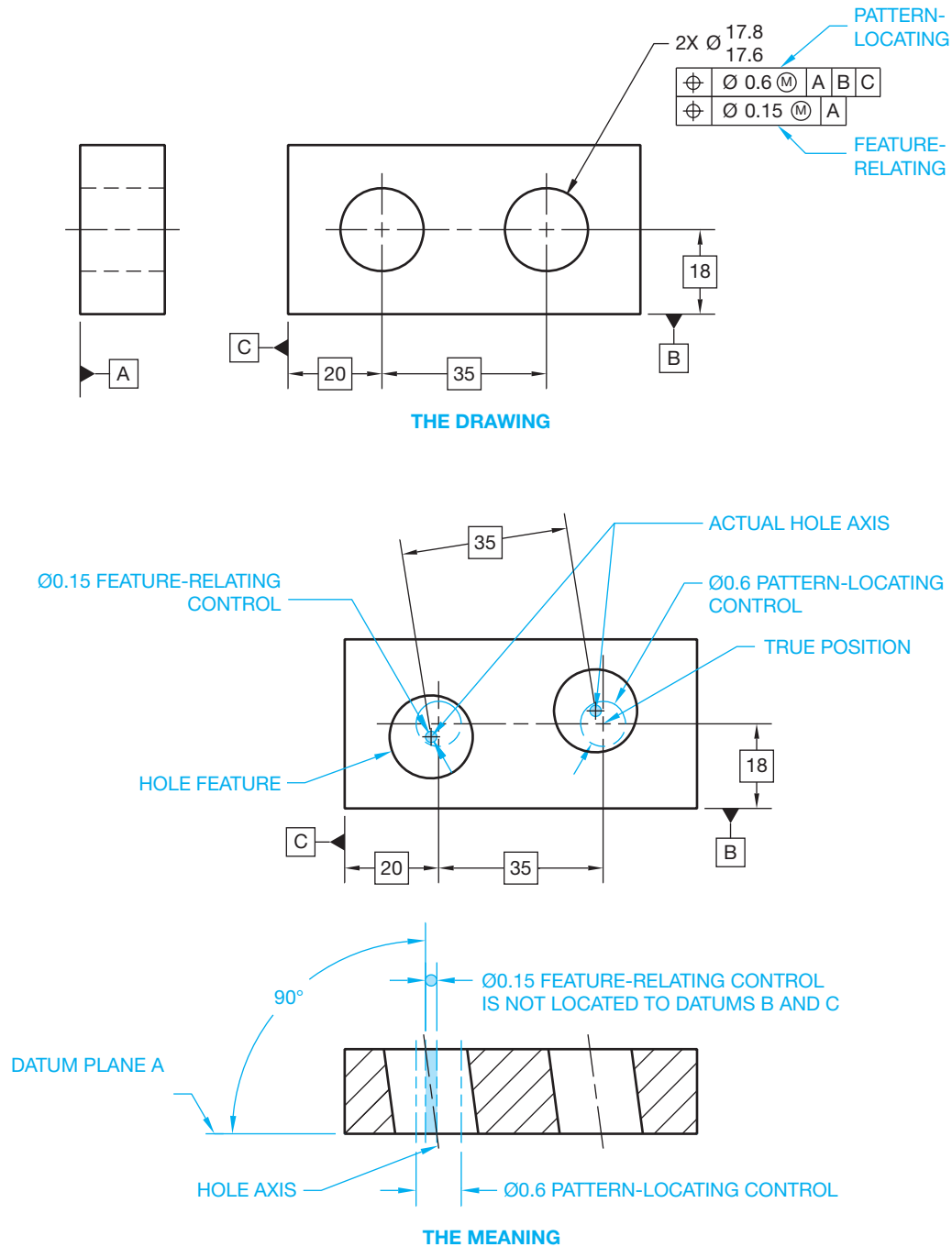
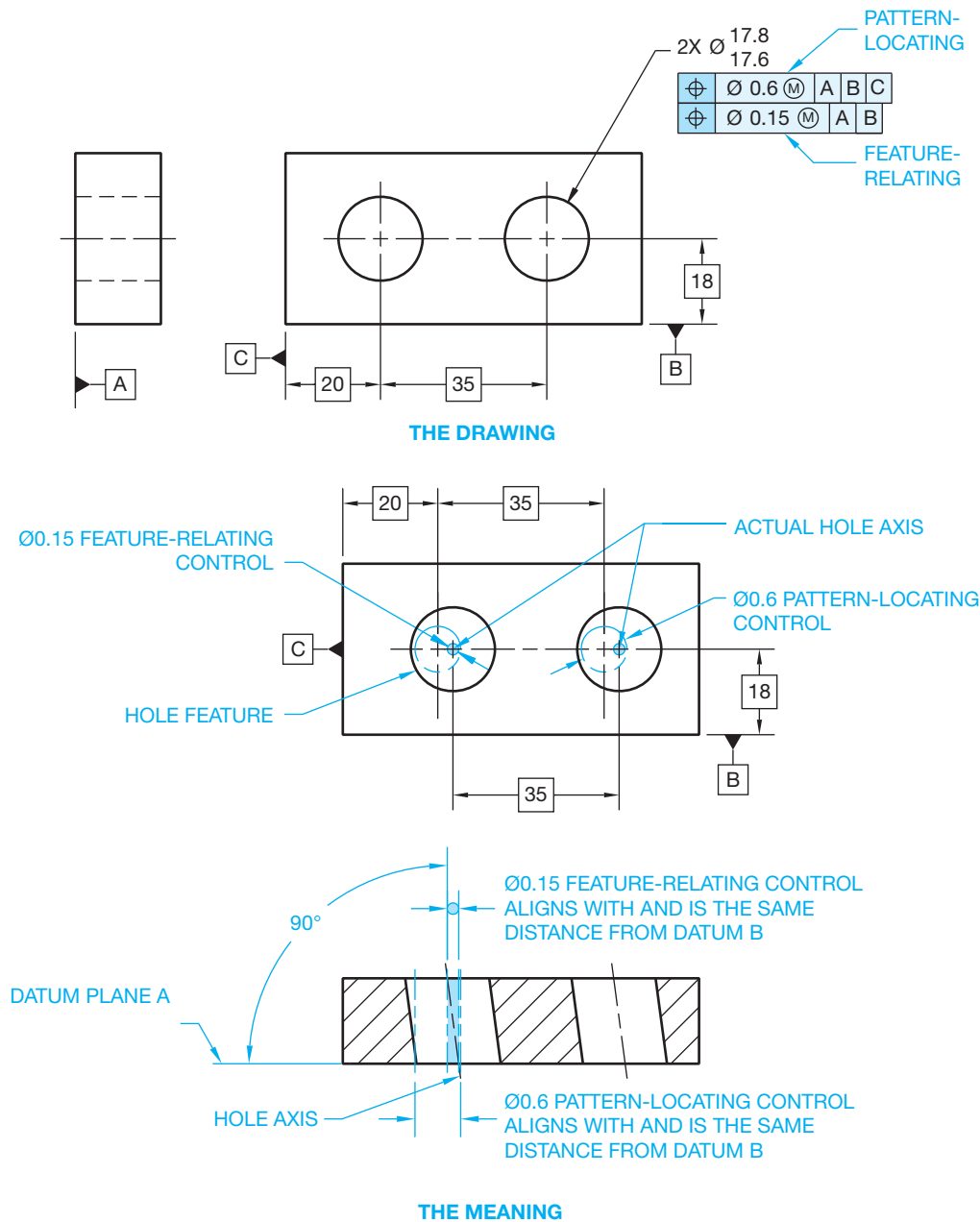


FIGURE 13.64 Composite positional tolerancing.

The actual feature axes must fall within the boundaries of both tolerance zones (see Figure 13.66).

Two single-segment feature controls can also be applied to circular patterns. The positional geometric characteristic symbol is displayed twice, as previously discussed. This is used when it is necessary for the pattern-locating zones and the feature-relating zones to be located from a common datum axis. Figure 13.67 shows datum B (the datum axis) placed in

both halves of the feature control frame. The slot and datum C are added to the part, so the two feature control frames do not cancel each other out. The top portion of the feature control frame controls the location of the features as a group to the datums. The slot and the tertiary datum are added to the pattern-locating control to provide orientation of the pattern of holes. The lower portion of the feature control frame controls the pattern of features related to each other.



**FIGURE 13.65** The two single-segment positional tolerance application. The feature-relating and pattern-locating controls align and are both the same distance from datum B. The basic location dimension from datum B applies to the feature-relating tolerance zone.

© Cengage Learning 2012

**Material Condition Requirements in Composite Positional Tolerancing**—Composite and two single-segment feature control frames must have the same material condition, and the datums must be in the same order of precedence with the same boundary condition. Two separate feature control frames are used when the same material condition is not required or the datum reference frames are different.

### Position Tolerancing of Coaxial Features

**Coaxial features** are features having a common axis, such as counterbores, countersinks, and counterdrills. When the positional tolerance of the coaxial features is to be the same, such as the same for the hole and the associated counterbore, then the feature control frame is placed below the

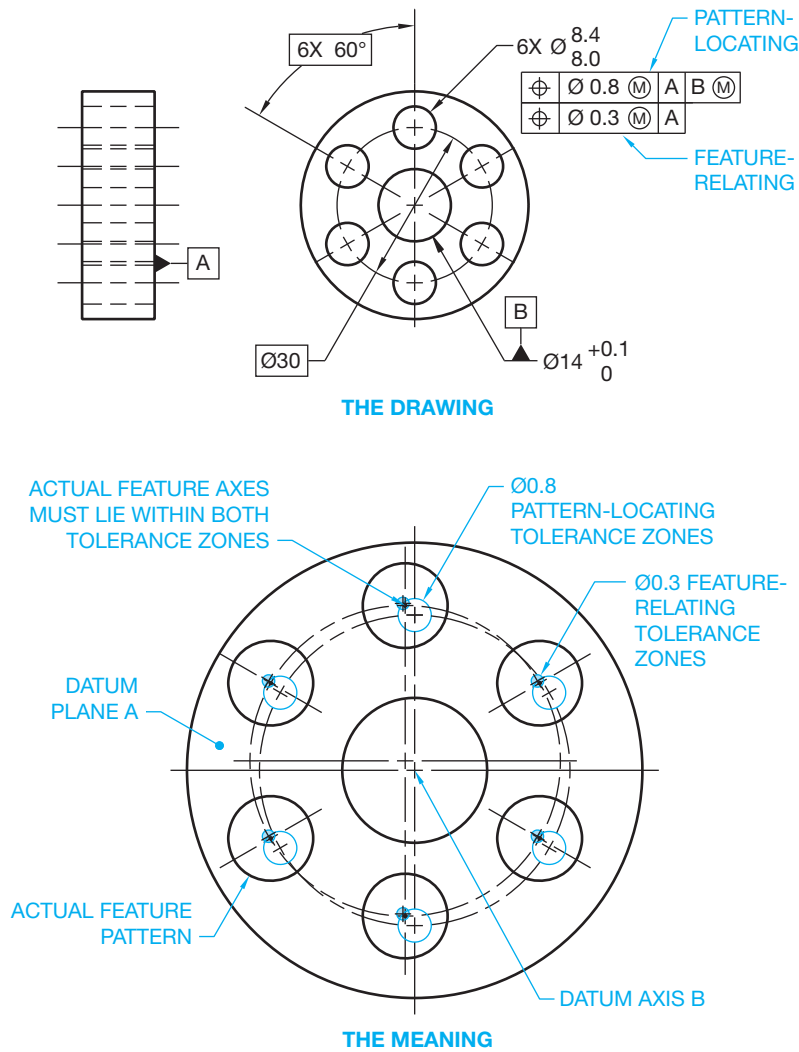


FIGURE 13.66 Composite positional tolerancing applied to circular patterns.

© Cengage Learning 2012

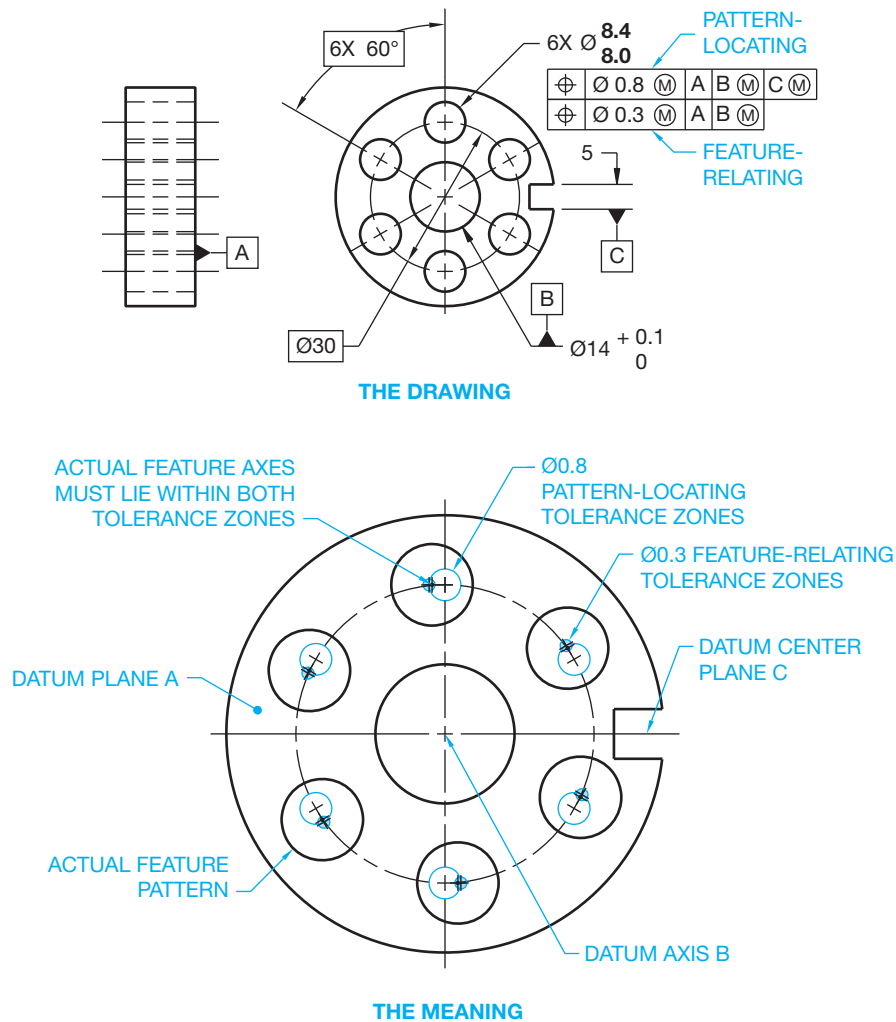
note specifying the hole and counterbore as shown in Figure 13.68. When this is done, the positional tolerance zone diameter is identical for the hole and counterbore relative to the specified datums.

Different positional tolerances can be applied to coaxial features related to the same datum features. For example, when the positional tolerance is different for the counterbore and the related hole, then one feature control frame is placed under the note specifying the hole size and another feature control frame is placed under the note specifying the counterbore (see Figure 13.69). This can occur when the counterbore is a different tolerance than the hole.

Positional tolerances can also be applied to coaxial features, such as counterbore holes, by controlling individual counterbore-to-hole relationships relative to different datum features. An additional note is placed under the datum feature symbol for the hole and under the feature control frame for the counterbore indicating the number of places each applies on an

individual basis. For example, if there are eight counterbores in the pattern, then the note for the hole and counterbore are separated to the view where they apply and the note 8X INDIVIDUALLY is placed below the counterbore note and with the related datum feature symbol. With this method, the holes are located as a single composite pattern and then the counterbores are located individually to each related hole, with the axis of the hole as the aligning datum.

**Coaxial Positional Tolerance of Features in Alignment**—In the previous coaxial feature discussion, counterbore features were described as being coaxial. This discussion is in regard to coaxial features that are established as holes that are apart but in alignment as shown in Figure 13.70. A coaxial positional tolerance can be used to control the alignment of two or more holes that share a common axis. The positional tolerance of two or more coaxial holes can be controlled as shown in Figure 13.70, where the positional tolerance zone of the holes is



**FIGURE 13.67** The two single-segment positional tolerance application for circular patterns.

© Cengage Learning 2012

located by basic dimensions from the referenced datums. Each hole can be produced at any location within the positional tolerance zone.

A composite position tolerance can also be used to locate coaxial holes. This is used when a tolerance of location alone does not provide the necessary control of alignment of the holes and a separate requirement must be specified. When this is done, the positional tolerance feature control frame is doubled in height. The top half of the frame is used to specify the coaxial diameter tolerance zones at MMC located at true position relative to the specified datums in which the axes of the holes must lie as a group. The lower half of the feature control frame is used to designate the coaxial diameter tolerance zones at MMC in which the axes of the holes must lie relative to each other.

When locating the positional tolerance of coaxial holes of different sizes, the different size holes are dimensioned independently and a note such as TWO COAXIAL HOLES, for two

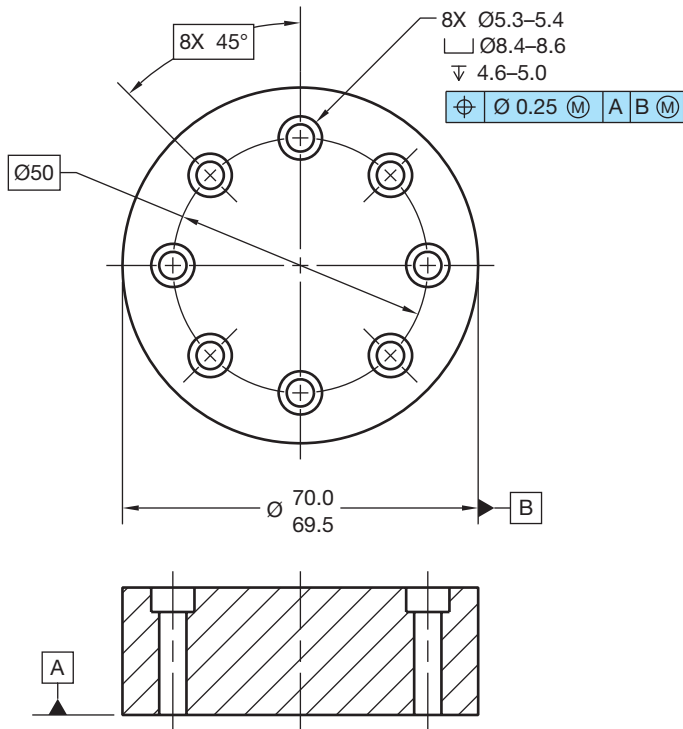
holes, is placed below the feature control frame. This specifies that the same positional tolerance zone requirements apply to all holes.

**Position Tolerancing of Nonparallel Holes**—Positional tolerances can be used in situations where the axes of the holes are not parallel to each other and where they can also be at an angle to the surface as shown in Figure 13.71.

### Locating Slotted Features

**Slotted features** can be located to their centers with basic dimensions from established datums. When a greater positional tolerance is placed on the length than on the width, the feature control frame is added to both the length and width dimensions of the slotted features. A bidirectional positional tolerance can be used when it is desired to specify a greater location tolerance in one direction than in the other direction. This type of positional tolerance results in a rectangular tolerance zone that





THE DRAWING

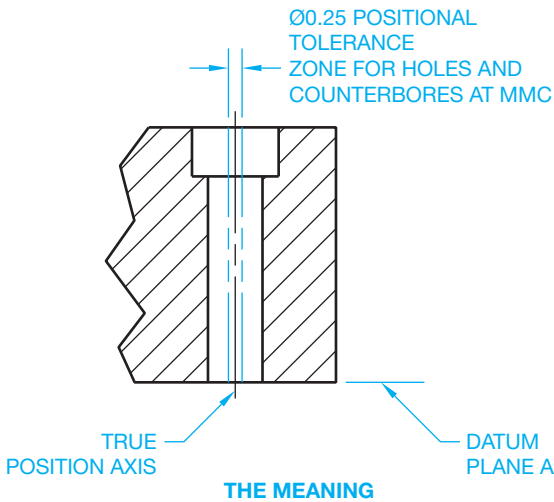
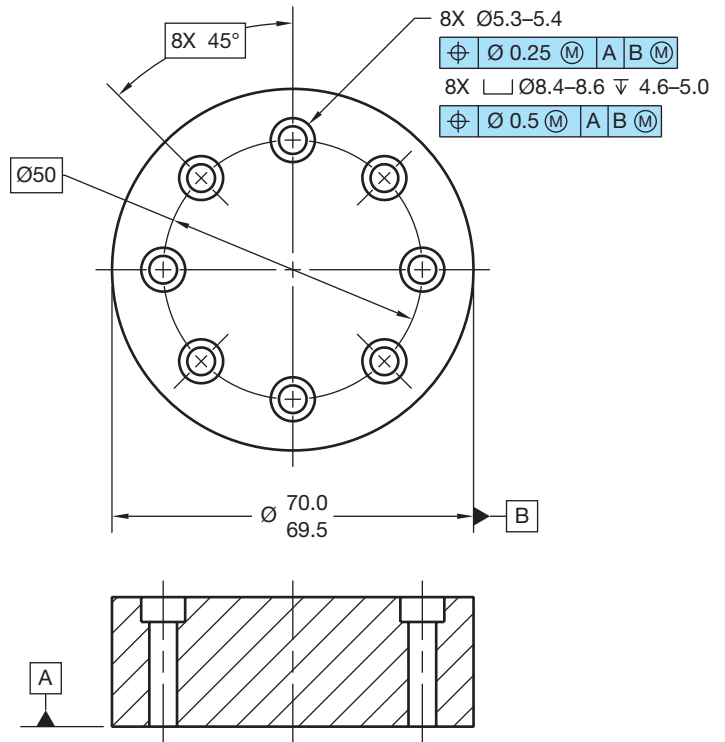


FIGURE 13.68 Using the same positional tolerance for coaxial features.  
© Cengage Learning 2012



THE DRAWING

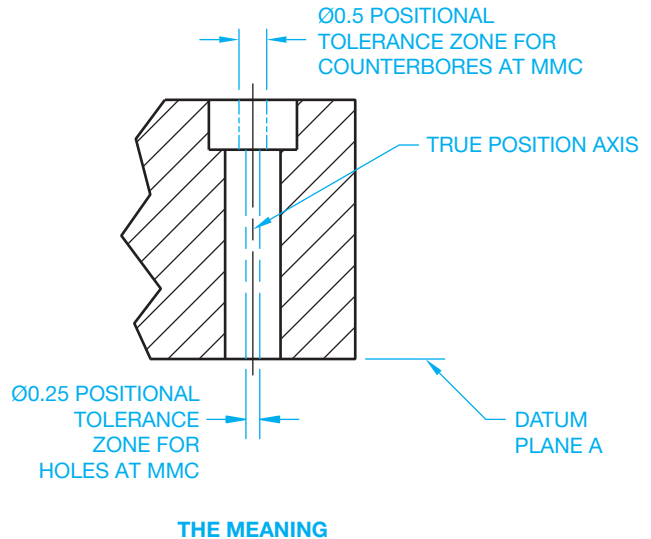


FIGURE 13.69 Using different positional tolerances for coaxial features.  
© Cengage Learning 2012

can be used for locating holes or slots. The diameter symbol is omitted from the feature control frame because the positional tolerance zone is noncylindrical as shown in Figure 13.72.

The positional tolerance zone for slotted features can also be controlled in relation to the surfaces of the feature (see Figure 13.73). This means that each slotted feature is controlled by a theoretical boundary of identical shape that is located at true position. The size of each slot must remain within the size limits, and no portion of the slot surface can enter the theoretical

boundary. The length and width of the boundary are calculated with the appropriate formulas:

$$\begin{aligned} \text{MMC length} - \text{Positional tolerance} &= \text{Boundary length} \\ \text{MMC width} - \text{Positional tolerance} &= \text{Boundary width} \end{aligned}$$

The positional tolerance can also be the same for the length and the width of the slot. In this case, the feature control frame is separated from the size dimension and is connected to the feature with a leader.

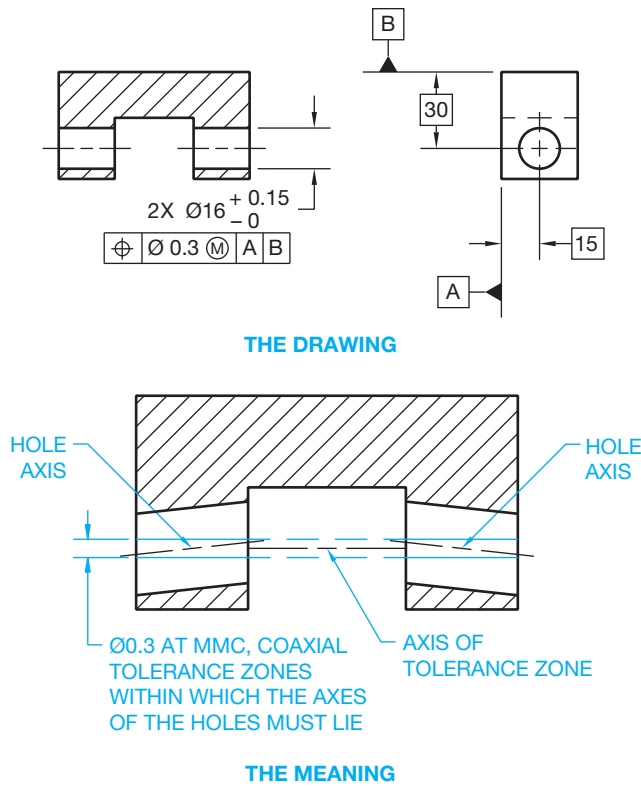


FIGURE 13.70 Controlling the positional tolerance of coaxial holes.

### Position Tolerancing of Spherical Features

A positional tolerance can be used to control the location of a spherical feature relative to other features of a part. When dimensioning spherical features, the spherical diameter symbol

precedes the feature size dimension. The feature control frame is placed below the size dimension, and the positional tolerance zone is spherical in shape as shown in Figure 13.74.

### Applying Positional Tolerancing to Fasteners

The following discussion involves positional tolerancing of fasteners and fastening devices. It is recommended that you review Chapter 11, *Fasteners and Springs*, if necessary. When applying geometric tolerances, such as orientation or location tolerances, to threaded fasteners, the tolerance is applied to the axis of a cylinder established by the pitch diameter of the thread. If it is necessary to apply the geometric tolerance of the screw thread to the major diameter or the minor diameter rather than the pitch diameter, then the note MAJOR DIA or MINOR DIA is placed below the related feature control frame or datum feature symbol. A thread symbol is used to represent the thread on the drawing, and a thread note provides the thread specifications. Figure 13.75a shows the drawing of an internal thread with no diameter note under the feature control frame, representing an application of the location tolerance to the axis of the cylinder established by the pitch diameter. Figures 13.75b and c show the optional MAJOR DIA and MINOR DIA notes applied under the feature control frame for specific applications, where the location tolerance is applied to the axis of the cylinder established by the major or minor diameter.

When the geometric tolerance and datum reference or datum feature are established for gears and splines, the specific feature of the gear or spline must be noted below the feature control frame or datum feature symbol. The options include MAJOR DIA, PITCH DIA, and MINOR DIA.

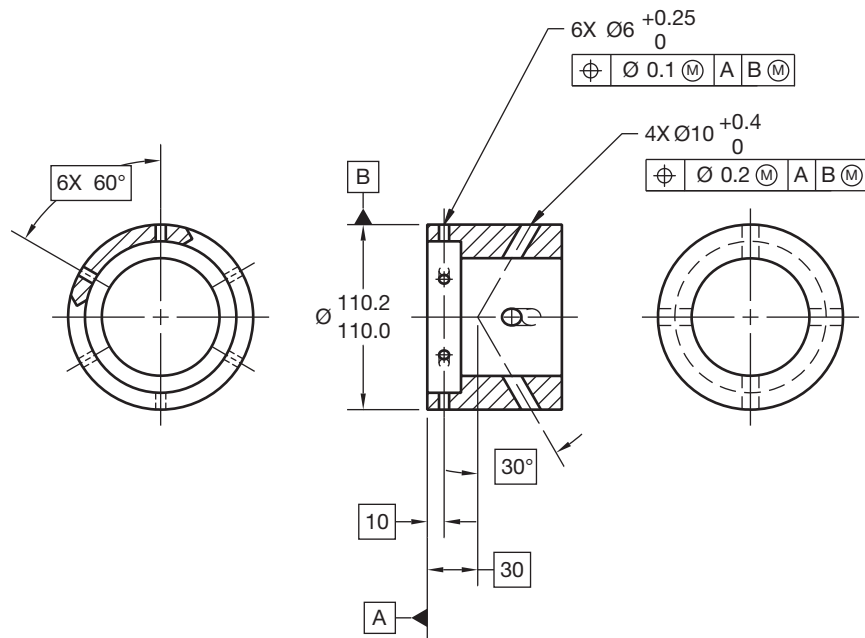


FIGURE 13.71 Positional tolerancing for nonparallel holes. © Cengage Learning 2012

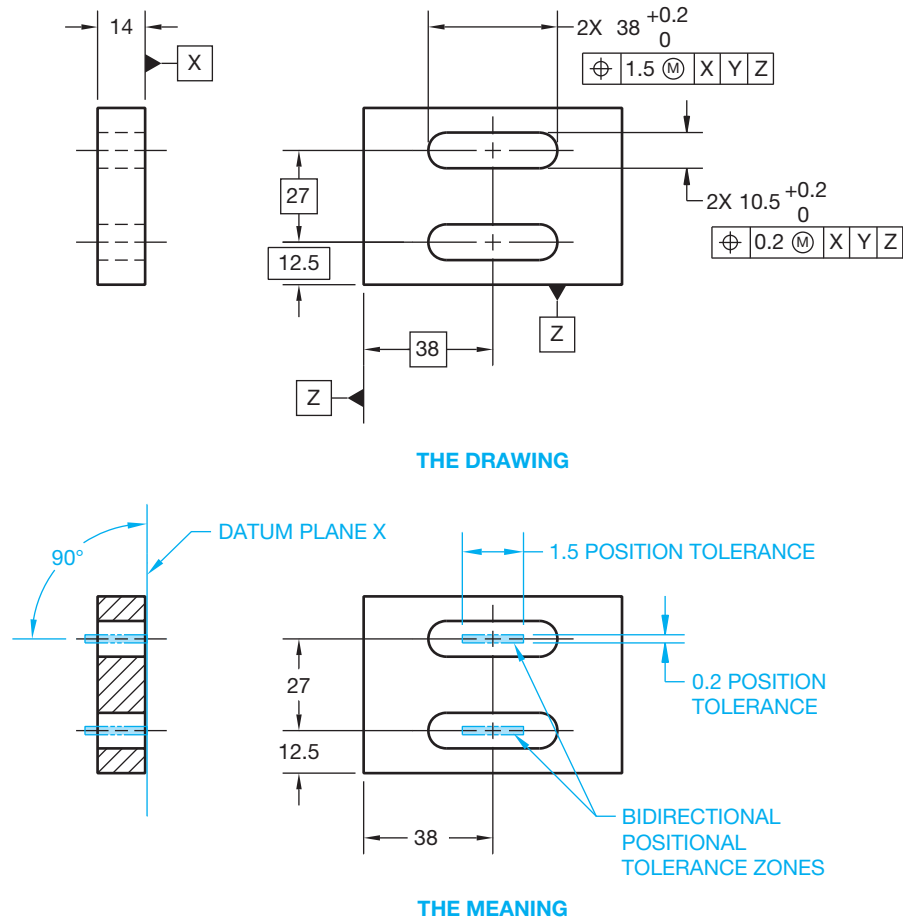


FIGURE 13.72 A bidirectional positional tolerance zone used for locating slotted features.

© Cengage Learning 2012

**Floating Fasteners**—The term **floating fastener** relates to an application in which two or more parts are assembled with fasteners, such as bolts and nuts, and all parts have clearance holes for the fasteners. A floating fastener application is shown in Figure 13.76. Notice that parts A and B are fastened together by a bolt, and a nut is required to hold the parts secure. When the holes in a pattern are the same diameters, the bolts used are the same diameters, and the same positional tolerance is used. Use the following formula to calculate the positional tolerance for each part separately:

**POSITIONAL TOLERANCE**

$$\text{MMC hole} - \text{MMC fastener (bolt)} = \text{For each part}$$

Given an application in which an M12 × 1.5 bolt is used to fasten two identical parts with a hole diameter of 13.0/12.5, the positional tolerance required can be calculated as:

$$\begin{aligned} &\text{MMC hole (12.5)} - \text{MMC bolt} \\ &(12) = \text{Positional tolerance (0.5)} \end{aligned}$$

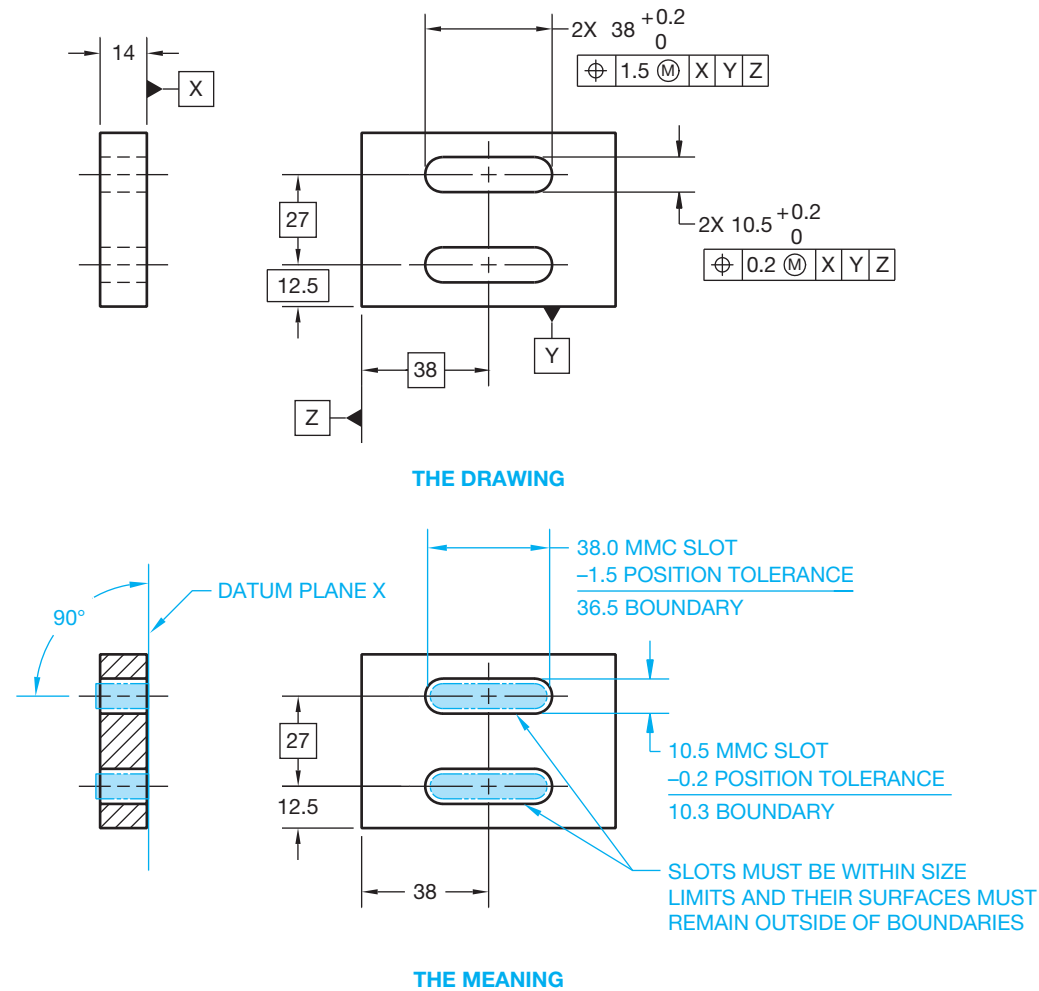
The MMC of a bolt is considered to be the nominal size, which is the same as the major diameter. The major diameter of the

M12 × 1.5 thread is 12 mm. The resulting drawing is shown in Figure 13.77.

**Fixed Fasteners**—The term **fixed fastener** relates to an application in which one of the parts to be assembled has a held-in-place fastener. This applies to all holes of the same size in a pattern in which the same positional tolerance is specified. Examples of a fixed fastener include a stud or a threaded hole for a bolt or screw. An example of a fixed fastener is shown in Figure 13.78. Notice in Figure 13.78 that part A has a clearance hole, and part B is threaded. Part B acts as part of the fastener, much like a nut. Therefore, a nut is not required as in the floating fastener application. Notice that only part A has clearance around the fastener. This means that half as much positional tolerance is applied as compared to a floating fastener. The fixed fastener positional tolerance is calculated using the formula:

$$\text{MMC hole} - \text{MMC fastener (bolt) positional tolerance} = 2 \text{ for each part}$$

Given an application in which an M14 × 2 bolt is used to fasten two parts together, where part A has a clearance hole diameter of 14.4/14.2 and part B is threaded with M14 × 2 thread



**FIGURE 13.73** Positional tolerancing for slotted holes using the boundary application. The positional tolerance can also be the same for the length and the width of the slot. In this case, the feature control frame is separated from the size dimension and is connected to the feature with a leader.

© Cengage Learning 2012

to accommodate the bolt, the positional tolerance is calculated as follows:

$$\begin{aligned} & \text{MMC hole (14.2)} - \text{MMC bolt} \\ & (14) = \text{Positional tolerance (0.1)} \end{aligned}$$

Notice in the calculation that the MMC of the fastener is the same as the major diameter. In this example, the M14 × 2 metric screw thread has a major diameter of 14. A drawing representing the positional tolerance calculation for this fixed fastener is shown in Figure 13.79.

The positional tolerance for a screw thread can be specified at MMC, but the extra tolerance gained by using MMC is minimal given tight screw thread tolerances. For this reason, an RFS application for the positional tolerance of screw threads is often preferred. This is because, in order to gage the position, a thread gage must be screwed into or onto the threaded feature. A gage is a device used to establish or obtain

measurements or to inspect a part or parts when verifying matching features.

In the RFS application, the thread gage uses the pitch diameter regardless of the manufactured screw thread size, which is the same as RFS. This can also be applied to press-fit pins, where the tolerance is so small that any bonus tolerance is negligible. MMC can be used on screw thread features when the minor diameter for an internal thread or major diameter for an external thread is specified.

**Fixed Fastener Application with Different Positional Tolerances Applied to Each Part**—Sometimes an engineer designs the positional tolerance between two or more parts in a fixed fastener application with a greater amount of positional tolerance applied to the unthreaded part. For example, 70% of the tolerance can be applied to the unthreaded part and 30% to the threaded part. Referring to Figure 13.79, the revised

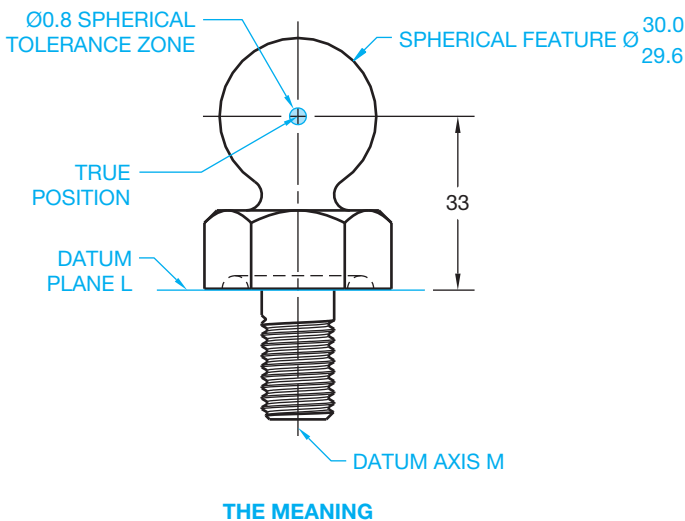
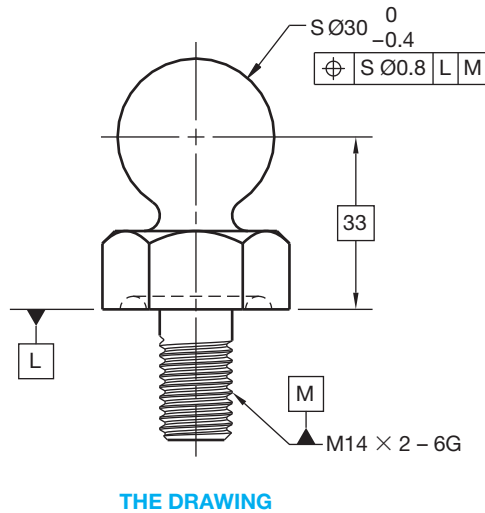


FIGURE 13.74 Positional tolerancing of a spherical feature.

positional tolerance for parts A and B can be calculated using the formula:

$$\begin{aligned} \text{MMC hole (14.2)} - \text{MMC bolt (14)} &= 0.2 \\ 0.2 \times 70\% (.70) &= 0.14 \text{ positional tolerance for part A} \\ 0.2 \times 30\% (.30) &= 0.06 \text{ positional tolerance for part B} \end{aligned}$$

### Applying a Projected Tolerance Zone

In some applications in which positional tolerance is used entirely for out-of-squareness, it is necessary to control perpendicularity and position above the part. The use of a **projected tolerance zone** is recommended when variations in perpendicularity of threaded or press-fit holes could cause the fastener to interfere with the mating part. A projected tolerance zone is usually specified for fixed fastener applications, such as the threaded hole for a bolt or the hole of a press-fit pin application.

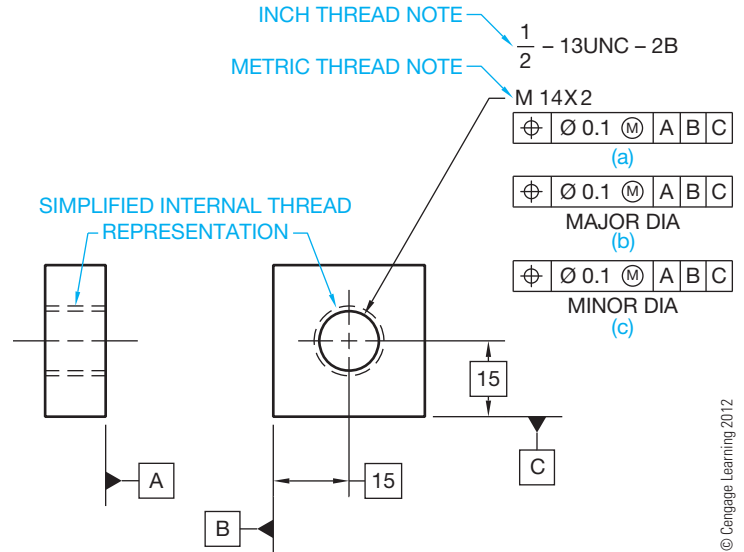


FIGURE 13.75 Internal screw thread representations. (a) A thread note with a location tolerance applied to the cylinder axis of the pitch diameter. (b) A thread note with a location tolerance applied to the cylinder axis of the major diameter. (c) A thread note with a location tolerance applied to the cylinder axis of the minor diameter.

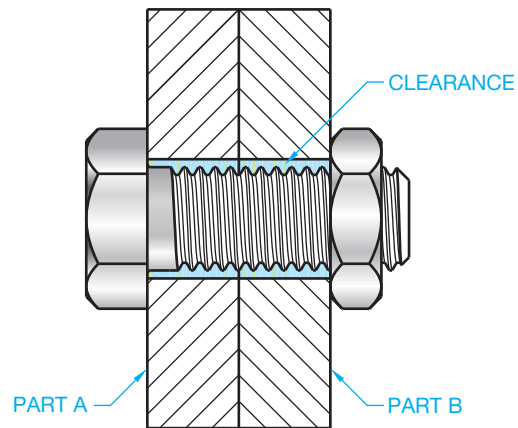


FIGURE 13.76 A floating fastener application.

The length of a projected tolerance zone is specified as the distance the fastener extends into the mating part, the thickness of the part, or the height of a press-fit stud. The normal positional tolerance extends through the thickness of the part as previously discussed. However, this application can cause an interference between the location of a thread or press-fit object and its mating part. This is because the attitude of a fixed fastener is controlled by the actual angle of the threaded hole. There is no clearance available to provide flexibility. For this reason, the projected tolerance zone is established at true position and extends entirely outside the part. The projected tolerance zone provides a bigger tolerance because it is projected outside the part, rather than within the thread. The projected

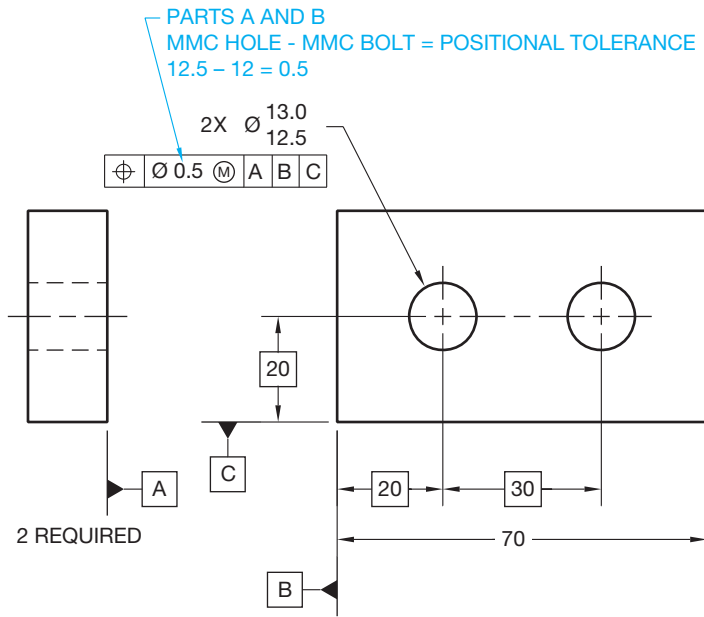


FIGURE 13.77 Calculating and showing the positional tolerance for a floating fastener application. © Cengage Learning 2012

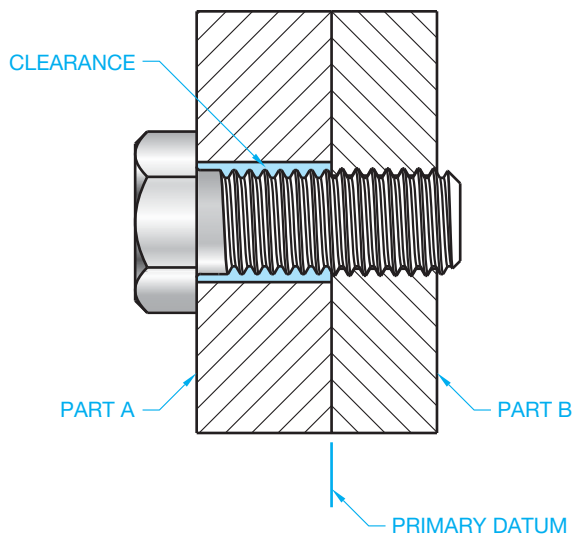


FIGURE 13.78 A fixed fastener application.

tolerance is also easier to inspect than the tolerance applied to the pitch diameter of the thread, because a thread gage with a post projecting above the threaded hole can be used with a coordinate measuring machine (CMM). A detailed example of the projected tolerance zone is shown in Figure 13.80.

The projected tolerance zone symbol is detailed in Figure 13.81. The projected tolerance zone representation can be shown on a drawing using the following applications.

One method for displaying the projected tolerance zone is where the projected tolerance zone symbol and height is placed in the feature control frame after the geometric tolerance and

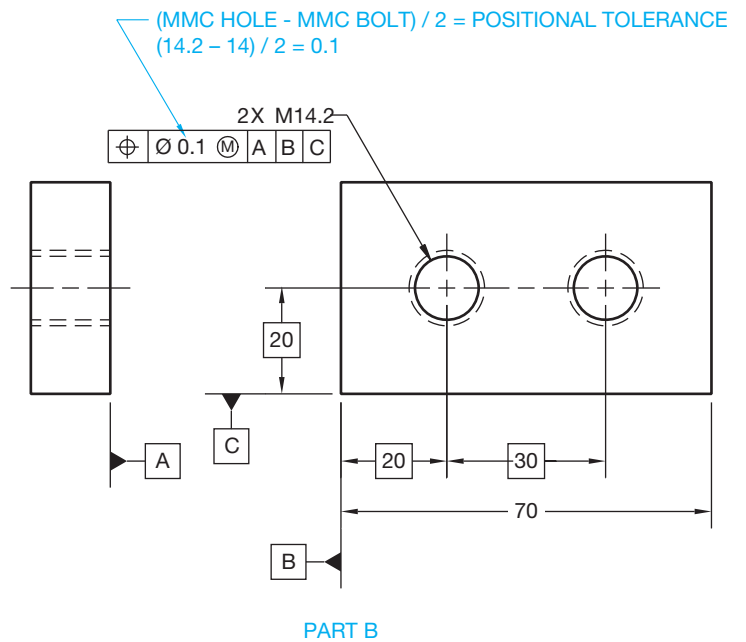
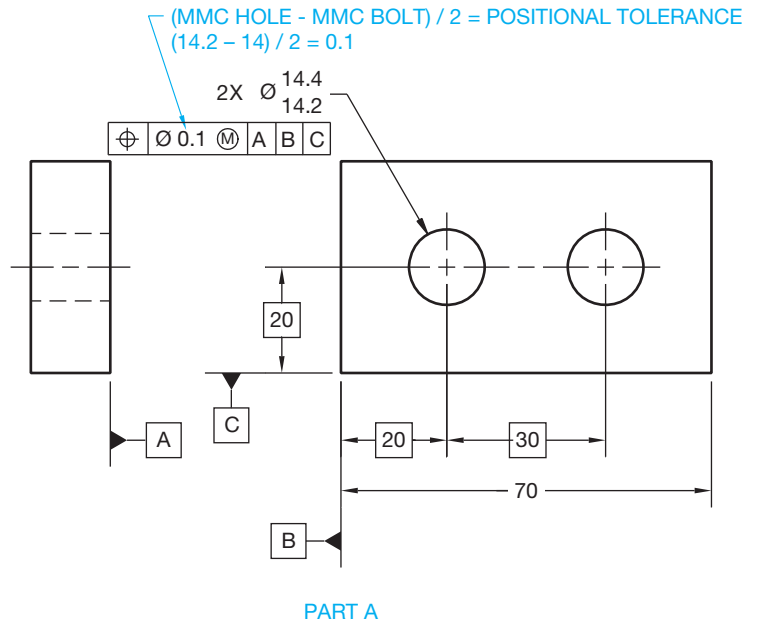


FIGURE 13.79 Calculating and showing the positional tolerance for a fixed fastener. © Cengage Learning 2012

related material condition symbol. The related thread specification is then connected to the section view of the thread symbol. With this method, the projected tolerance zone is assumed to extend away from the threaded hole (see Figure 13.81).

To provide additional clarification, the projected tolerance zone can be shown using a chain line in the view where the related datum appears as an edge. The minimum height of the projection is also dimensioned. Refer to Figure 13.82. When this is done, the projected tolerance zone symbol is shown alone in the feature control frame after the geometric tolerance and material condition symbol, if any.

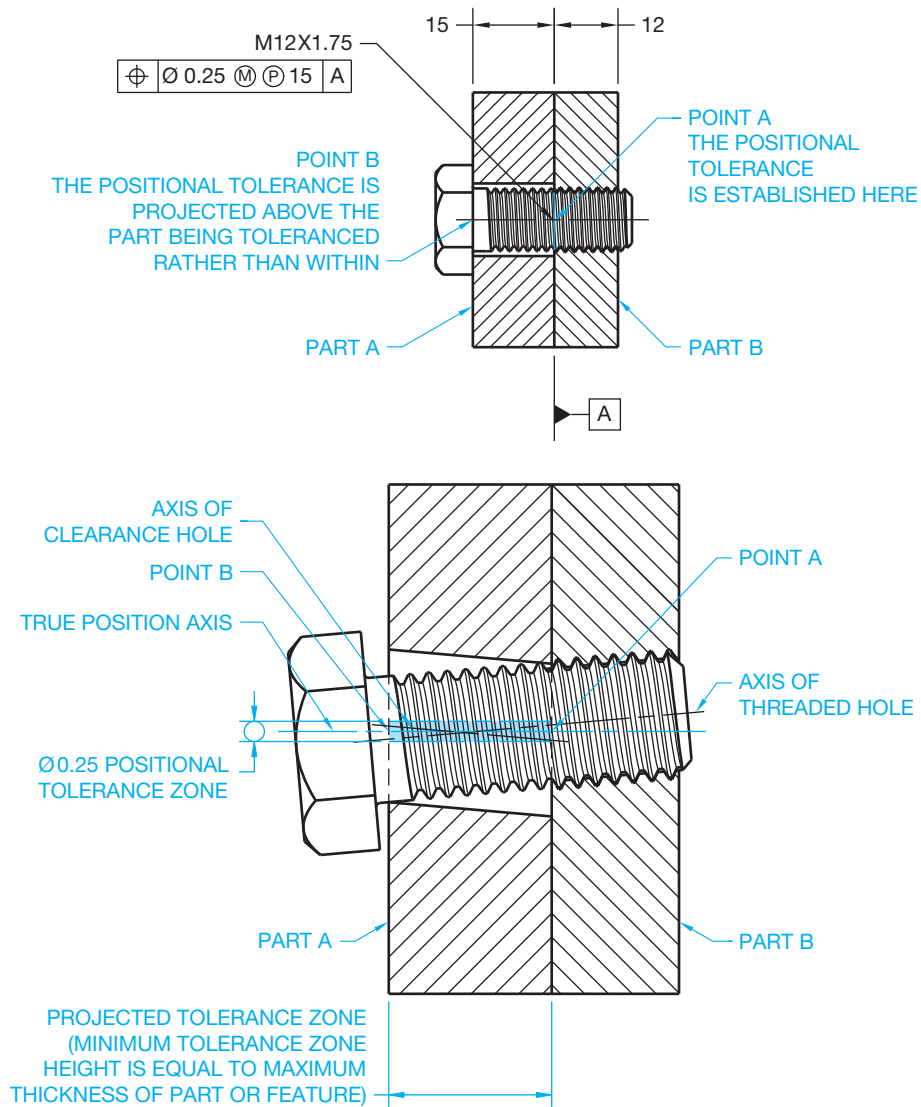


FIGURE 13.80 A projected tolerance zone. © Cengage Learning 2012

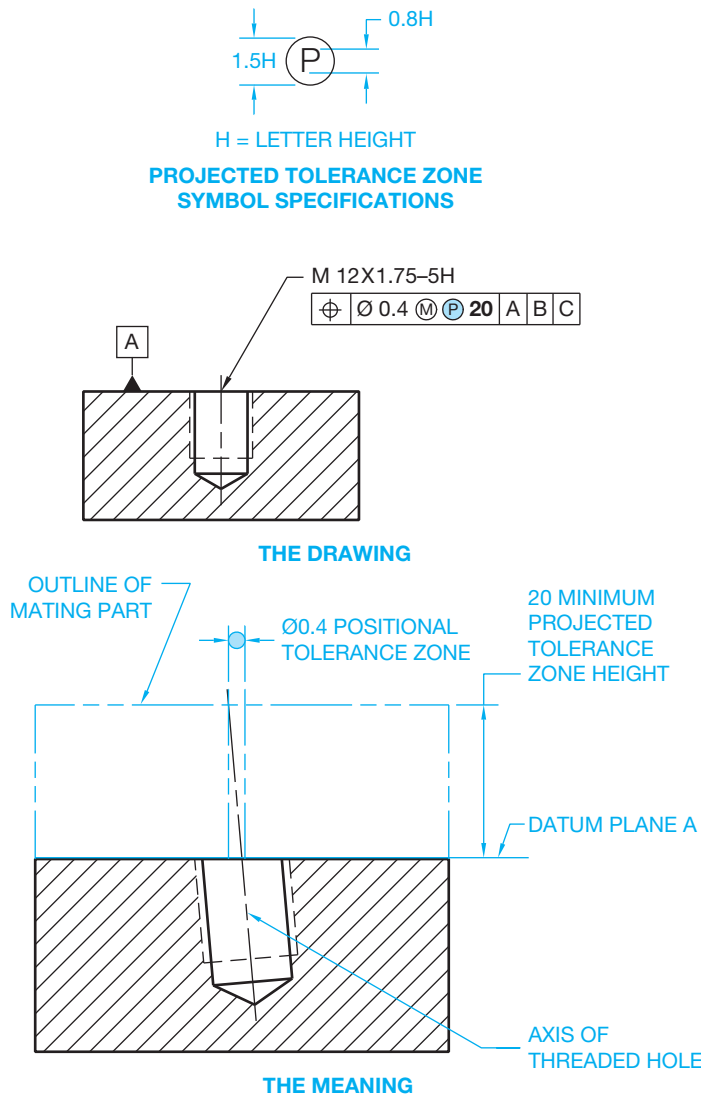
The projected tolerance zone is often established by a positional tolerance that controls location and perpendicularity. A perpendicularity geometric tolerance can be used to provide a tighter control than that allowed by the positional tolerance. Either of the previously discussed representation techniques can be used when specifying projected perpendicularity.

### Virtual Condition

Virtual condition was briefly introduced earlier in this chapter to provide basic information related to zero positional tolerancing. Virtual condition is a boundary that takes into consideration the combined effect of feature size at MMC and geometric tolerance. Virtual condition establishes a working zone that is used to establish gage member sizes and the MMC size of mating parts or fasteners for mating parts. The virtual condition

represents extreme conditions at MMC plus or minus the related geometric tolerance. This is used to determine clearance between mating parts. It is important to determine the virtual condition when designing mating parts. For example, if a bolt is intended to pass through a hole and the bolt head is to rest flat on the surface, then the bolt diameter can be no bigger than the MMC of the hole minus the geometric tolerance. This is the virtual condition. It is not possible to be certain of interchangeability of mating parts if virtual condition is violated. The virtual condition of a feature must be interchangeable with the virtual condition of its mating part. The virtual condition is calculated for applications involving internal or external features. When calculating the virtual condition of an internal feature, use the following formula:

$$\text{MMC size of the feature} - \text{related geometric tolerance} = \text{virtual condition}$$



**FIGURE 13.81** A projected tolerance zone representation with the length of the projected tolerance zone given in the feature control frame. © Cengage Learning 2012

Look at the part shown in Figure 13.83 and see the related virtual condition calculation.

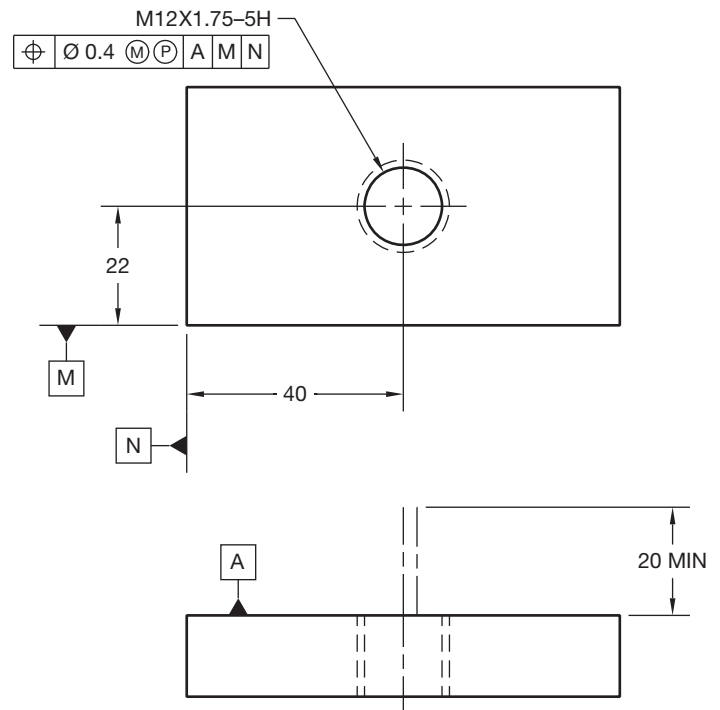
When calculating the virtual condition of an external feature, use the following formula:

$$\text{MMC size of the feature} + \text{related geometric tolerance} = \text{virtual condition}$$

Look at the part shown in Figure 13.84 and see the related virtual condition calculation.

### Zero Positional Tolerance at MMC with the Clearance Hole at Virtual Condition

An application of zero positional tolerance at MMC is used with the design of the MMC of clearance holes at virtual condition as shown in Figure 13.85. Notice that the MMC of the hole is



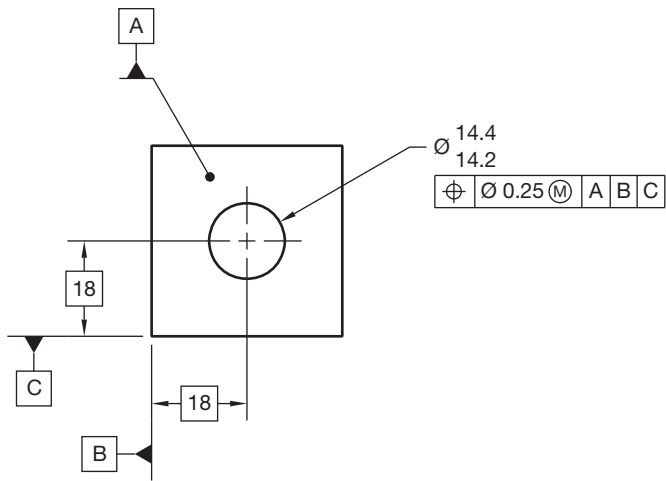
**FIGURE 13.82** A projected tolerance zone representation with the length of the projected tolerance zone shown with a chain line and a minimum dimension in the adjacent view. © Cengage Learning 2012

the same as the virtual condition calculated in Figure 13.85. As previously explained, virtual condition establishes the working zone that is used to establish the MMC size of mating parts. Therefore, starting with the virtual condition as the MMC of the feature and allowing the produced size to increase with the MMC application is a realistic approach.

## Concentricity Geometric Tolerance

A **concentricity** tolerance is used to establish a relationship between the axes of two or more cylindrical features of an object. Concentricity establishes a **median** point to axis control. The median is the middle value in a set or distribution of points. The concentricity geometric characteristic symbol is shown detailed in a feature control frame in Figure 13.86a. Perfect concentricity exists when the axes of each cylindrical feature fall on the same centerline. Concentricity is the condition where the axis of each cross-sectional element of a cylindrical surface is common with the axis of a datum feature. The concentricity tolerance specifies a cylindrical (diameter) tolerance zone. The axis of this tolerance zone coincides with a datum axis. All of the median points that originate from the feature surface must be within the cylindrical concentricity tolerance zone as shown in Figure 13.86b. The specified concentricity geometric tolerance is applied only on an RFS basis, and the related datum reference is applied only on an RMB basis.

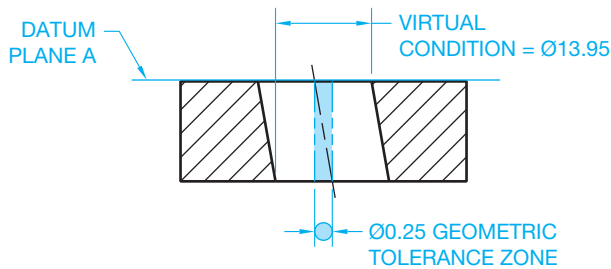




THE DRAWING

$$\begin{aligned} \text{MMC HOLE} &= 14.20 \\ - \text{GEOMETRIC TOLERANCE} &= 0.25 \\ \hline \text{VIRTUAL CONDITION} &= 13.95 \end{aligned}$$

THE CALCULATION



THE MEANING

	POSSIBLE PRODUCED SIZES	GEOMETRIC TOLERANCES AT GIVEN PRODUCED SIZES	VIRTUAL CONDITION
MMC →	14.2	0.25	13.95
	14.3	0.35	13.95
LMC →	14.4	0.45	13.95

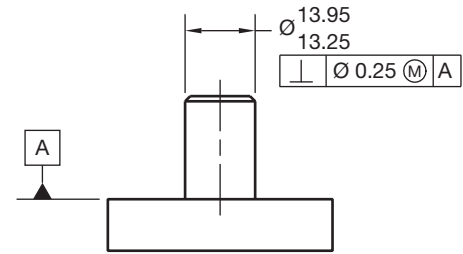
© Cengage Learning 2012

FIGURE 13.83 Calculating the virtual condition of an internal feature.



**NOTE:** As noted in ASME Y14.5, irregularities in the form of an actual feature to be inspected can make it difficult to establish the location of a feature's median points. Finding the median points of a feature can require time-consuming analysis of surface variations. It is recommended that runout or positional tolerancing be used unless it is absolutely necessary to control a feature's median points. Runout is discussed later in this chapter.

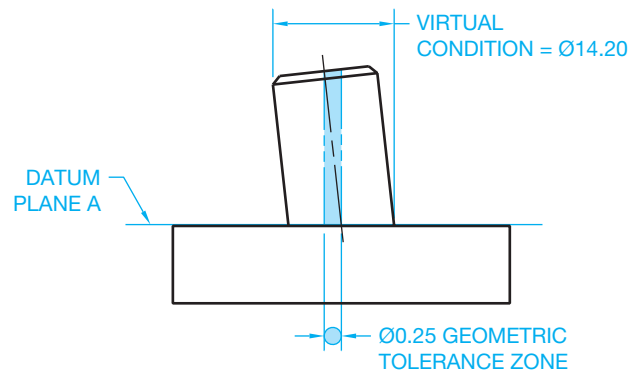
Positional tolerancing is recommended over concentricity tolerancing when the control of the axes of cylindrical features can be applied on a material condition basis. Positional tolerancing is an axis-to-axis control when applied to control coaxiality. A coaxial relationship can be controlled by specifying a



THE DRAWING

$$\begin{aligned} \text{MMC PIN} &= 13.95 \\ + \text{GEOMETRIC TOLERANCE} &= 0.25 \\ \hline \text{VIRTUAL CONDITION} &= 14.20 \end{aligned}$$

THE CALCULATION



THE MEANING

	POSSIBLE PRODUCED SIZES	GEOMETRIC TOLERANCES AT GIVEN PRODUCED SIZES	VIRTUAL CONDITION
MMC →	13.95	0.25	14.2
	13.85	0.35	14.2
	13.75	0.45	14.2
	13.65	0.55	14.2
	13.55	0.65	14.2
	13.45	0.75	14.2
	13.35	0.85	14.2
LMC →	13.25	0.95	14.2

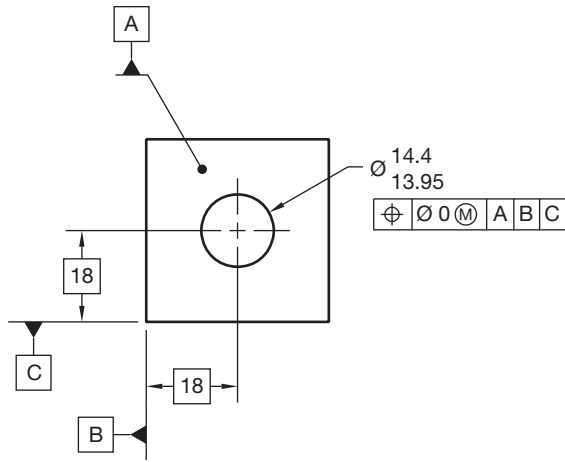
© Cengage Learning 2012

FIGURE 13.84 Calculating the virtual condition of an external feature.

positional tolerance at MMC and the datum feature reference on an MMB, LMB, or RMB basis, depending on the design requirements.

### Symmetry Geometric Tolerance

A symmetry tolerance is a center plane relationship of the features of an object establishing a median point to center plane control. The symmetry geometric tolerance is a zone where the median points of opposite symmetrical surfaces align with the datum center plane. The symmetry geometric characteristic symbol is shown detailed in a feature control frame in Figure 13.87a. The symmetry geometric tolerance is applied only on an RFS basis, and the related datum reference is applied only



	POSSIBLE PRODUCED SIZES	GEOMETRIC TOLERANCES AT GIVEN PRODUCED SIZES	VIRTUAL CONDITION
MMC →	13.95	0	13.95
	14	0.05	13.95
	14.1	0.15	13.95
	14.2	0.25	13.95
LMC →	14.3	0.35	13.95
	14.4	0.45	13.95

FIGURE 13.85 Specifying zero positional tolerance at MMC with the MMC of the clearance hole equal to virtual condition.

on an RMB basis (see Figure 13.87b). The same difficulties discussed in inspecting the median points of a feature for concentricity should also be considered when using symmetry. If this control is not required, then the positional tolerance locating symmetrical features should be considered.

### Positional Tolerancing Locating Symmetrical Features

Perfect symmetry or true position occurs when the center planes of two or more related symmetrical features line up. Positional tolerancing is a center plane to center plane control when applied to control symmetrical features. A positional tolerance is used when it is required to locate one or more features symmetrically with respect to the center plane of a datum feature. The drawing is similar to the drawing in Figure 13.81b except a positional symbol replaces the symmetry symbol in the feature control frame and controlling median points is not required. The diameter symbol is omitted in front of the positional tolerance in the feature control frame. This is because the given tolerance zone is the distance between two parallel planes equally divided on each side of true position, rather than a cylindrical tolerance zone, as described in other applications. A material condition symbol identifying MMC or LMC must accompany the positional tolerance, otherwise RFS is assumed.

Positional tolerancing of symmetrical slots or tabs can be accomplished by identification of related datums, by dimensioning the relationship between slots or tabs, by providing the number

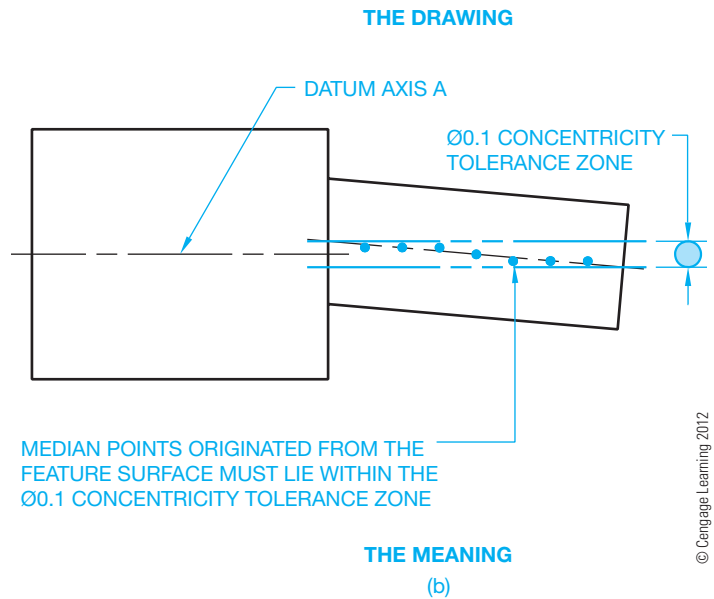
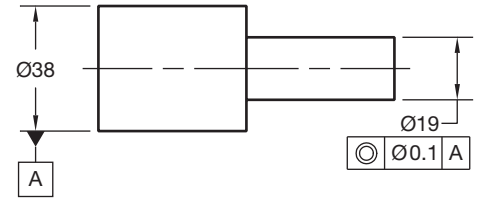
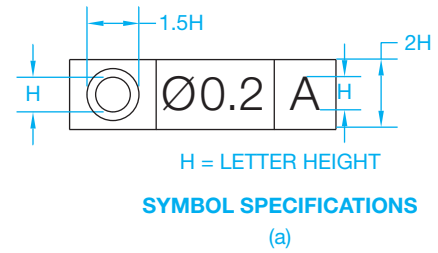
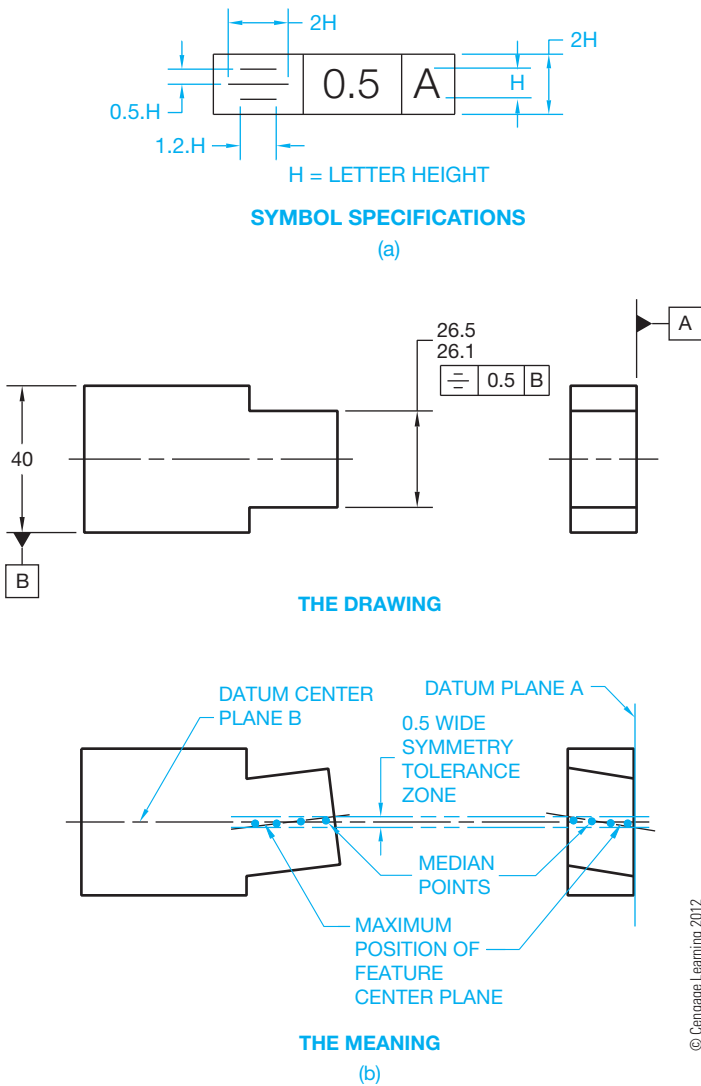


FIGURE 13.86 (a) The concentricity geometric characteristic symbol in a feature control frame. (b) Application of the concentricity geometric tolerance.

of units followed by the size, or by a feature control frame with a positional tolerance. The diameter symbol is omitted from the feature control frame, and a material condition symbol is required as shown in Figure 13.88; otherwise, RFS is assumed.

### Zero Positional Tolerance at MMC for Symmetrical Objects

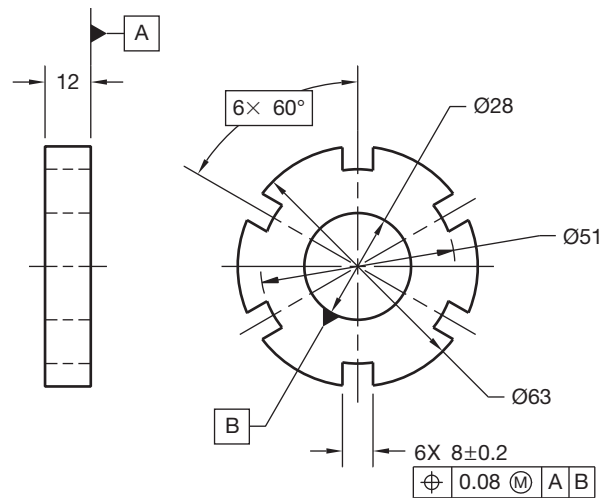
A zero positional tolerance at MMC can be used when it is necessary to control the symmetry relationship of features within their limits of size. In this application, the datum feature is usually specified on an MMB basis. When the positional controlled feature is at MMC and the datum feature is at MMB, then perfect symmetry occurs and a boundary of perfect form is established. Imperfect symmetry only happens as the produced size leaves MMC. This is similar to the application of zero positional tolerance at MMC previously discussed.



**FIGURE 13.87** (a) The symmetry geometric characteristic symbol in a feature control frame. (b) Application of the symmetry geometric tolerance.

## APPLYING PROFILE GEOMETRIC TOLERANCES

This section covers the concepts and techniques of dimensioning and tolerancing to control the profile of geometric shapes. **Profile** geometric tolerances control the form, orientation, or location of straight lines or surfaces, arcs, and irregular curves. Profile can be characterized as the outline of an object represented by either an external view or a cross section through the object. The **true profile** or actual desired shape of the object is the basis of the profile tolerance. The true profile should be defined by basic dimensions in most applications. The **profile tolerance** specifies a uniform boundary along the true profile within which the elements of the surface must lie. Profile can be used to control form or combinations of size, form, and orientation. When used as a refinement of size, the profile tolerance must be contained within the size tolerance. Profile



**FIGURE 13.88** Showing positional tolerancing of slots. Positional tolerancing of tabs is handled in the same manner.

geometric tolerances are always regardless of feature size. Profile tolerances are always equally disposed bilateral unless otherwise specified.

In an equally disposed bilateral tolerance, the tolerance zone is split equally on each side of true profile. Profile tolerances can be specified as unequally disposed bilateral or as unilateral tolerance zones. In an unequally disposed bilateral tolerance, the tolerance zone is split on each side of true profile, but the distance on each side is not equal. In a unilateral tolerance, the entire tolerance zone is on one side of the true profile. A profile tolerance can also be specified between two given points, all around the object, or all over the entire part. The term *disposed* refers to the distribution of material added to or removed from the part on the specified side of true profile. A profile tolerance is specified by using a leader to connect the feature control frame to the view or section that clearly shows the intended profile. There are two types of profile geometric tolerances: profile of a line and profile of a surface.

## Profile of a Line

The **profile of a line** tolerance is a two-dimensional or cross-sectional geometric tolerance that extends along the length of the feature. The profile of a line symbol and associated feature control frame are shown in Figure 13.89a. The datum reference is provided in the feature control frame because the profile geometric tolerance zone is generally oriented to one or more datums. Profile of a line is used when it is not necessary to control the profile of the entire feature. A profile of a line tolerance is used in situations in which parts or objects have changing cross sections throughout the length. A pump impeller is an example of a part that has changing cross sections. Datums are used in some situations but are not necessary when the only requirement is the profile shape taken at various cross sections. When the leader from the

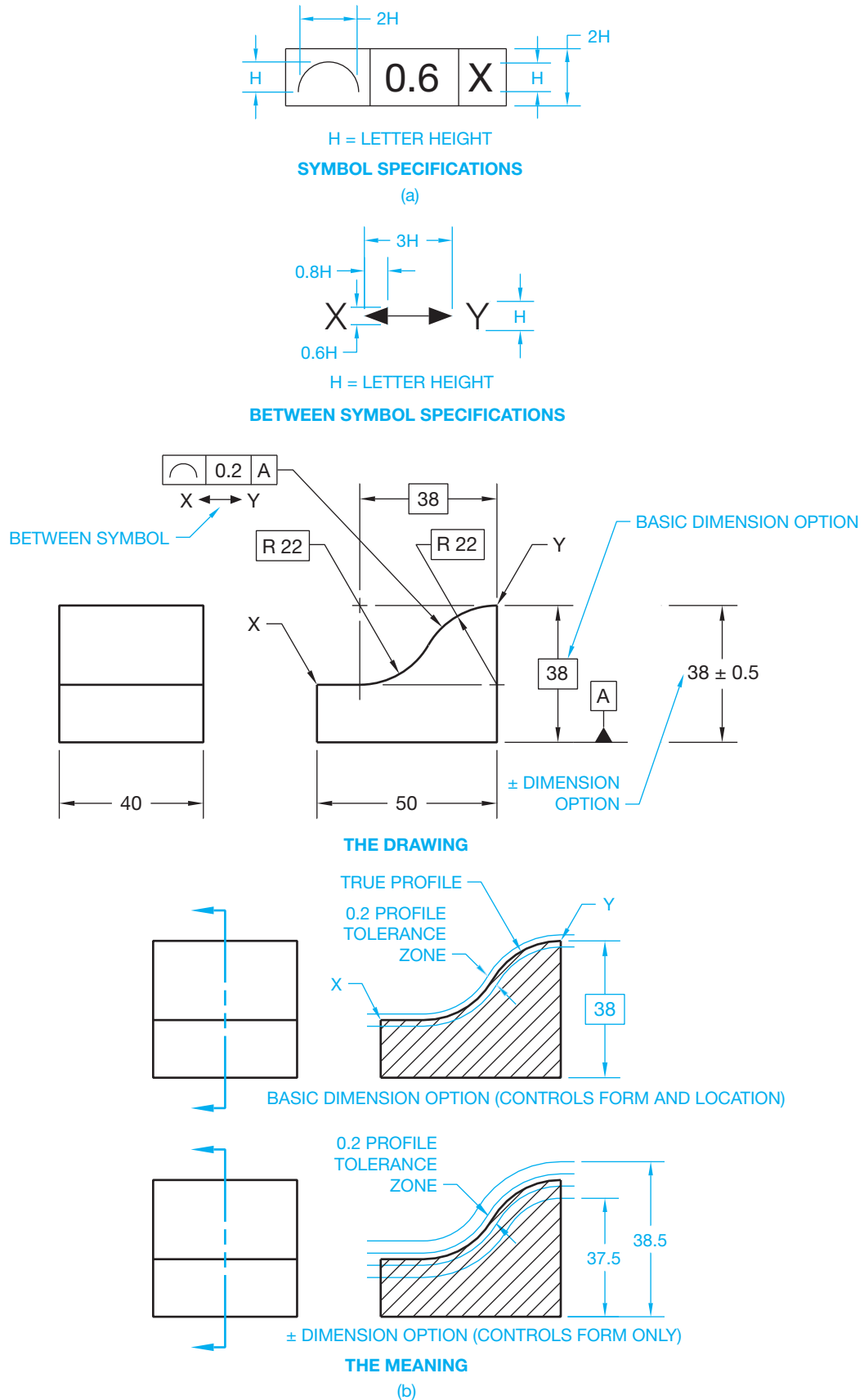


FIGURE 13.89 (a) A feature control frame with the profile of a line geometric characteristic symbol and datum reference. (b) A profile of a line tolerance specified between two points.

feature control frame extends to the related surface without any additional clarification, then the profile tolerance is assumed to be bilateral. Equally disposed bilateral tolerances are equally split on each side of the basic dimensions that establish true profile.

### Profile of a Line between Two Points

The profile tolerance can be between two given points of the object. This specification is shown by using the between symbol under the feature control frame. Any combination of letters can be used, such as A and B, C and D, or X and Y. The true profile is established by a basic or tolerance dimension. Profile of a line is a single cross-sectional check anywhere along the intended surface. The profile tolerance is assumed to be **equally disposed bilateral** unless otherwise specified. This means that the profile tolerance is split equally on each side of the true profile. The actual profile of the feature is confined within the profile tolerance zone (see Figure 13.89b). In the example shown, the profile tolerance is equally disposed bilateral and has an equal disposition of 0.1 mm on each side of the true profile.

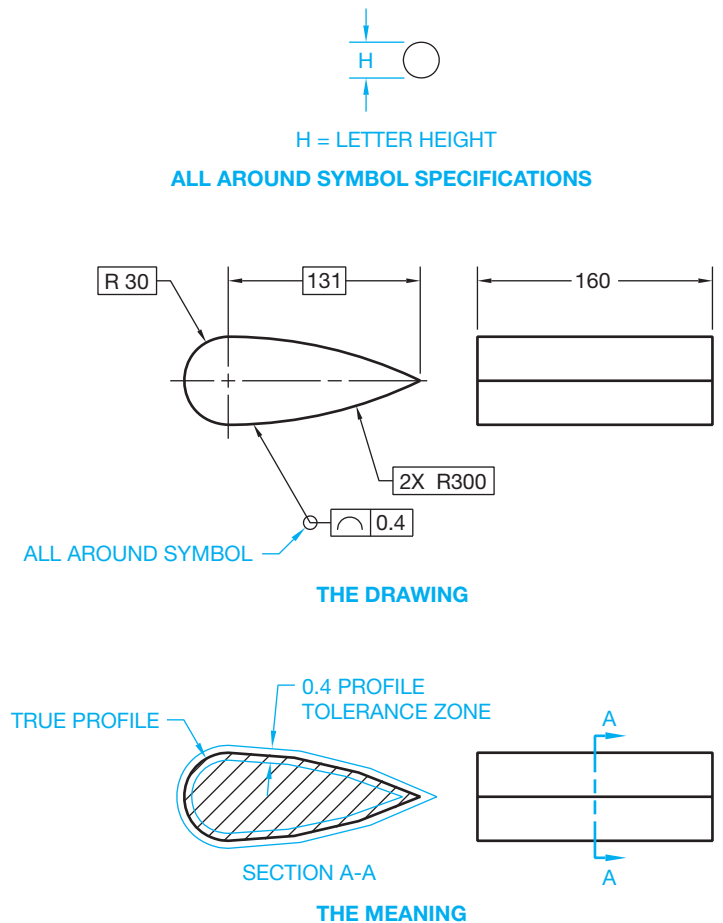
### Profile of a Line All Around

Profile of a line can also specify a tolerance zone that goes around the entire object. When this is desired, the feature control frame is connected to the object with a leader as previously described, and the all-around symbol must be placed on the leader as shown in Figure 13.90, and a note indicating between two points is excluded. The specification in Figure 13.90 is assumed to be a bilateral profile of a line tolerance equally split 0.2 mm on each side of the true profile.

### Unilateral and Unequally Disposed Profile of a Line

An equally disposed bilateral profile tolerance is assumed unless unilateral or unequally disposed specifications are provided. In a **unilateral profile**, the entire tolerance zone is on one side of the true profile. When a unilateral profile tolerance is required, the **unequally disposed symbol** is placed after the geometric tolerance in the feature control frame as shown in Figure 13.91. When the unilateral profile tolerance has material added to the feature or part, the profile tolerance value is repeated after the unequally disposed symbol. The feature control frame is connected to the edge view of the surface with a leader line. This is the preferred ASME Y14.5 use for the application shown in Figure 13.91.

When the unilateral profile tolerance has material taken from the feature or part, the profile tolerance value is placed before the unequally disposed symbol, and a 0 is placed after the unequally disposed symbol to denote that the entire profile tolerance is inside of true profile. The feature control frame is connected to the edge view of the surface with a leader line as

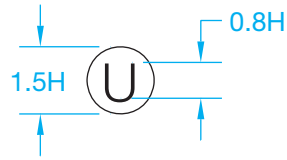


**FIGURE 13.90** A profile of a line tolerance specified all around.  
© Cengage Learning 2012

shown in Figure 13.92. This is the preferred ASME Y14.5 use for this application.

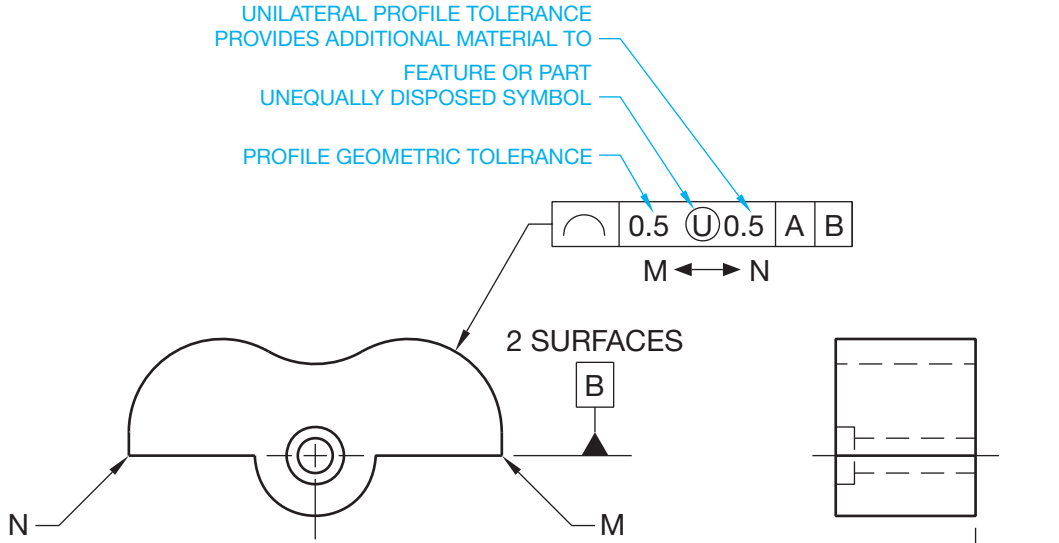
When the profile tolerance is not equally split on each side of true profile, the total profile tolerance value is placed before the unequally disposed symbol in the feature control frame, and the value of the tolerance that adds material to the feature or part is placed after the unequally disposed symbol. The feature control frame is connected to the edge view of the surface with a leader line as shown in Figure 13.93. This is the preferred ASME Y14.5 use for this application.

An alternate method is used when the profile tolerance is unequally disposed. It displays the total tolerance inside the feature control frame. Either the inside or outside of true profile is shown as a basic dimension. Figure 13.94 shows the unequally disposed profile tolerance on the inside as a basic dimension of 0.2. The same result can be achieved by showing a basic dimension of 0.3 on the outside. One or the other must be dimensioned to show which way the tolerance applies and how much profile tolerance is allowed inside or outside. A dimension line with arrowheads is placed on each side of the phantom lines and connects the feature control frame with a leader. The basic dimension is required because the true profile is defined by basic dimensions and the tolerance zone must also be defined



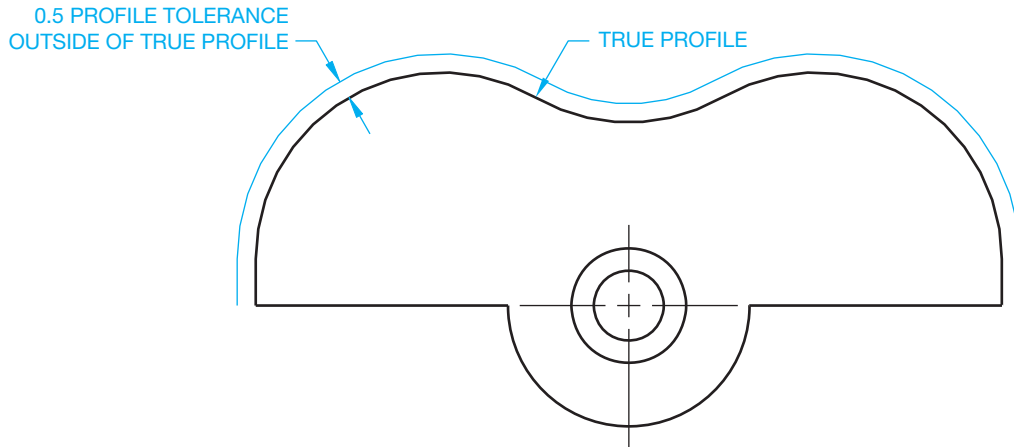
H = LETTER HEIGHT

**UNEQUALLY DISPOSED  
SYMBOL SPECIFICATIONS**



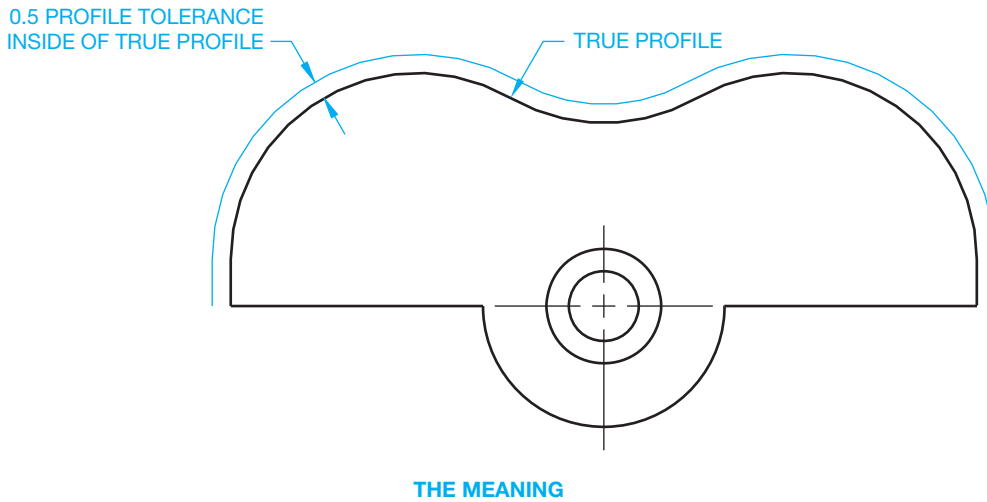
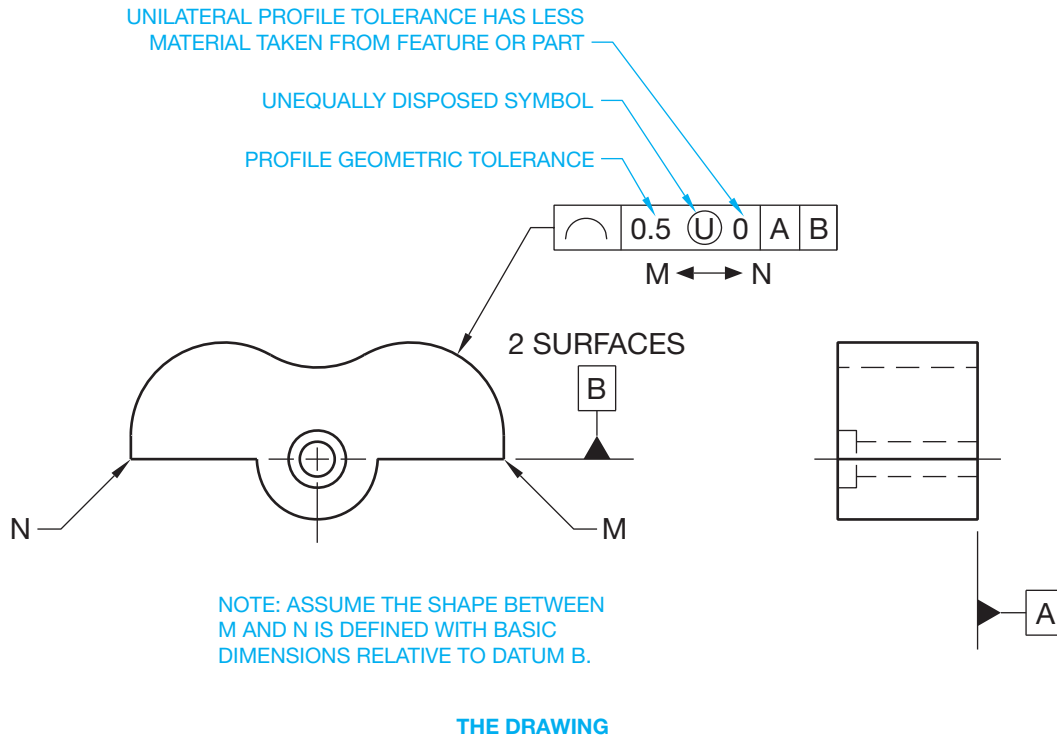
NOTE: ASSUME THE SHAPE BETWEEN M AND N IS DEFINED WITH BASIC DIMENSIONS RELATIVE TO DATUM B.

**THE DRAWING**



**THE MEANING**

**FIGURE 13.91** An application of a unilateral profile tolerance where the entire profile tolerance provides additional material to the feature or part. This is the preferred ASME Y14.5 use for this application.



**FIGURE 13.92** An application of a unilateral profile tolerance where the entire profile tolerance removes material from the feature or part. This is the preferred ASME Y14.5 use for this application.

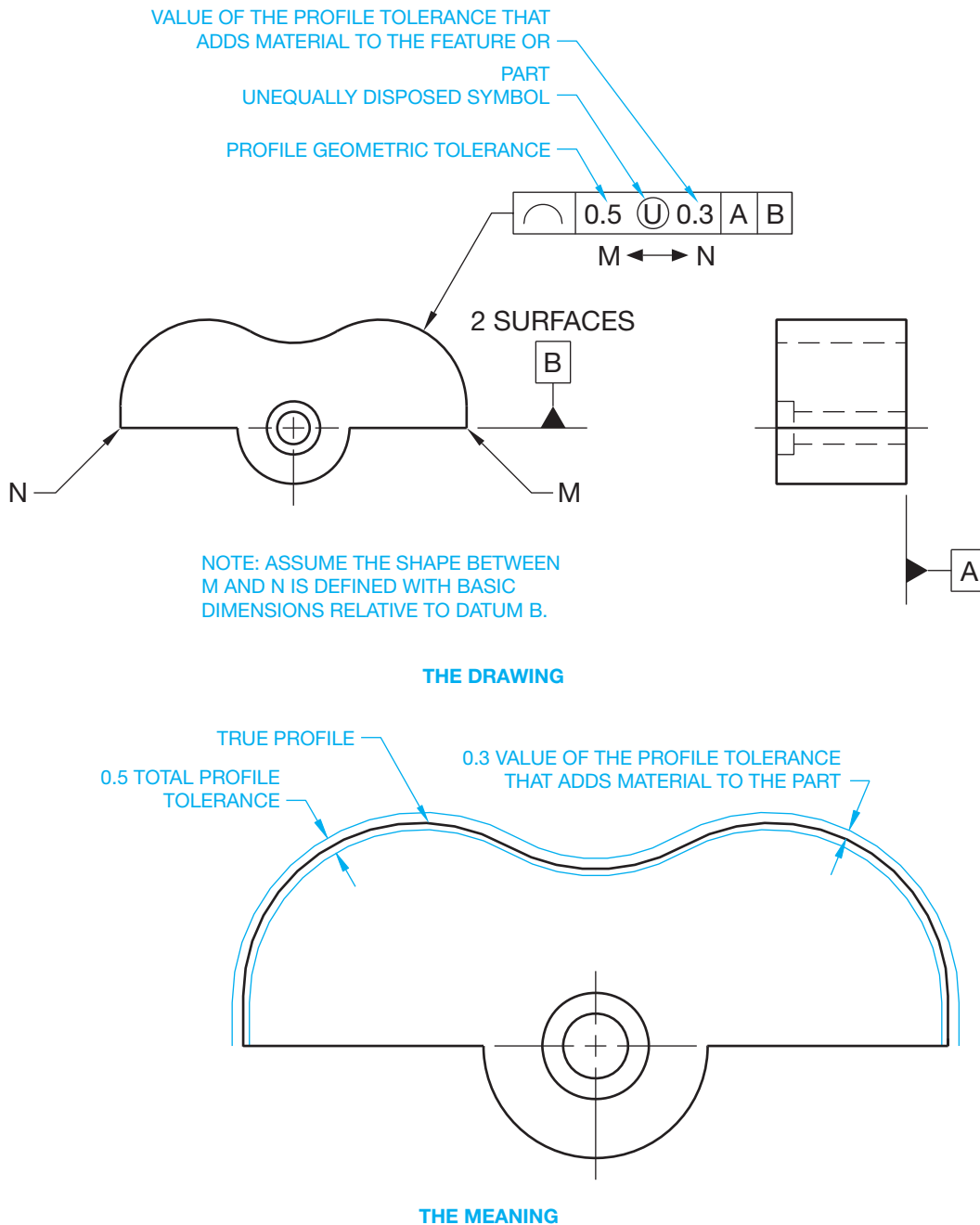
© Cengage Learning 2012

as basic. The actual profile of the part must be between the basic zone created around the true profile.

An alternate option when a unilateral profile tolerance is required is to draw a short phantom line parallel to the true profile on the side of the intended unilateral tolerance. A dimension line with arrowhead is placed on the far side, and a leader line connects the feature control frame on the other side as shown in Figure 13.95.

## Profile of a Surface

A **profile of a surface** tolerance is used when it is desired to control the entire surface as a single feature. The profile of a surface geometric characteristic and associated feature control frame are detailed in Figure 13.96a. Profile of a surface is a blanket tolerance that is three-dimensional and extends along the total length and width or circumference of the object or feature(s). In



© Cengage Learning 2012

**FIGURE 13.93** An application of an unequally disposed profile tolerance. This is the preferred ASME Y14.5 use for this application.

most cases, the profile of a surface tolerance requires reference to datums for proper orientation of the profile.

### Profile of a Surface Between Two Points

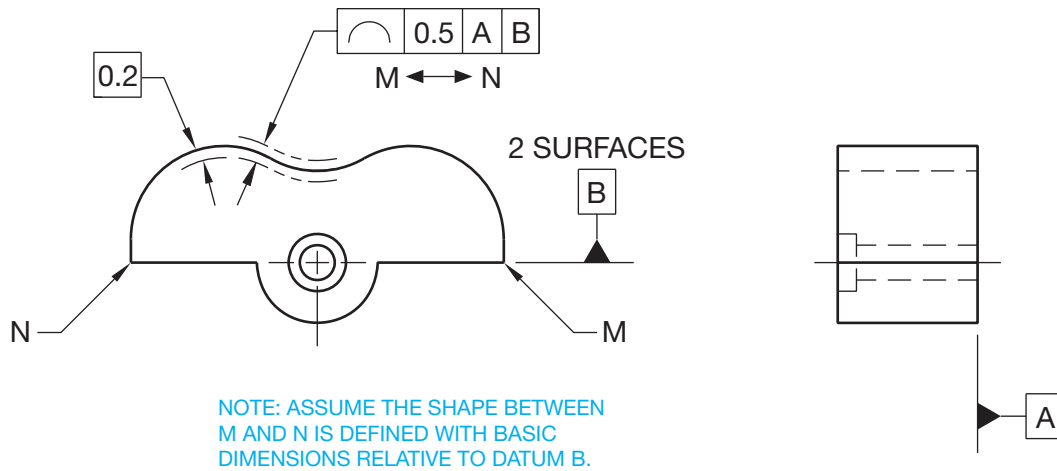
The profile of a surface tolerance zone is equally disposed bilateral unless otherwise specified, just as for the profile of a line. The profile of a surface can be between two points and

is handled in the same manner used for profile of a line between two points. A sample drawing and its related meaning are shown in Figure 13.96b.

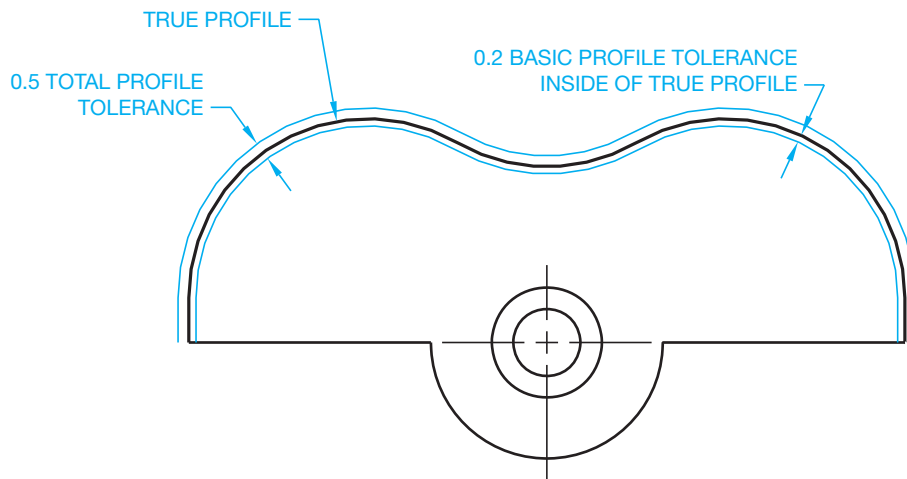
### Profile of a Surface All Around or All Over

Surface profile can also be applied to completely blanket objects that have a constant uniform cross section by placing the





THE DRAWING



THE MEANING

FIGURE 13.94 Using a basic dimension to indicate an unequally disposed profile tolerance.

© Cengage Learning 2012

all-around symbol on the leader line. When this is done, surfaces all around the object outline must lie between two parallel boundaries equal in width to the given geometric tolerance. The tolerance zone should also be perpendicular to a datum plane (see Figure 13.97). The all-over symbol, shown in Figure 13.97, is used when it is necessary for the profile tolerance zone to be all over the entire part.

### Profile of a Sharp Corner

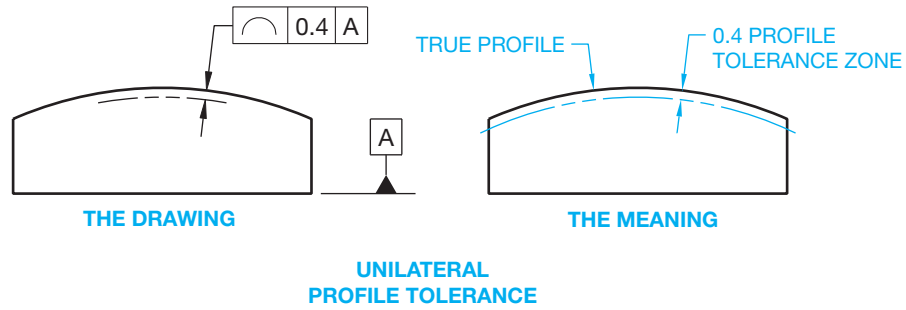
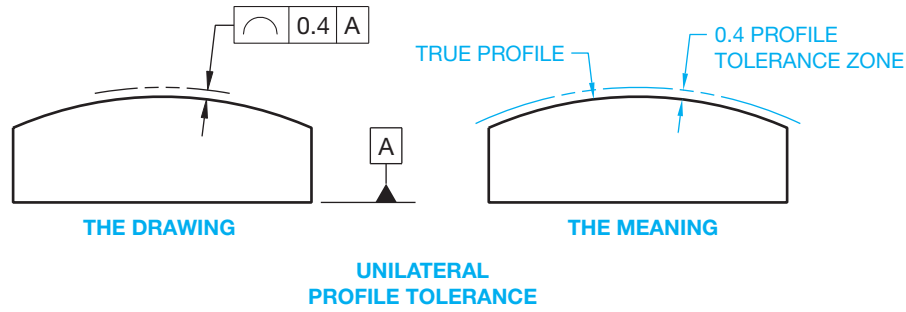
When a profile tolerance is at a sharp corner, the tolerance zone extends to the intersection of the boundary lines. In these situations, a rounded corner can occur because the actual surface can be anywhere within the tolerance zone boundary. If this roundness must be controlled, then a maximum radius note shall be added to the drawing. The drawing in Figure 13.97 has the note R0.2 MAX to indicate this.

### Unilateral or Unequally Disposed Profile of a Surface

The profile of a surface can also be specified as a unilateral or unequally disposed tolerance using the same options available for the profile of a line previously described. The following options correlate with the drawing shown in Figure 13.98.

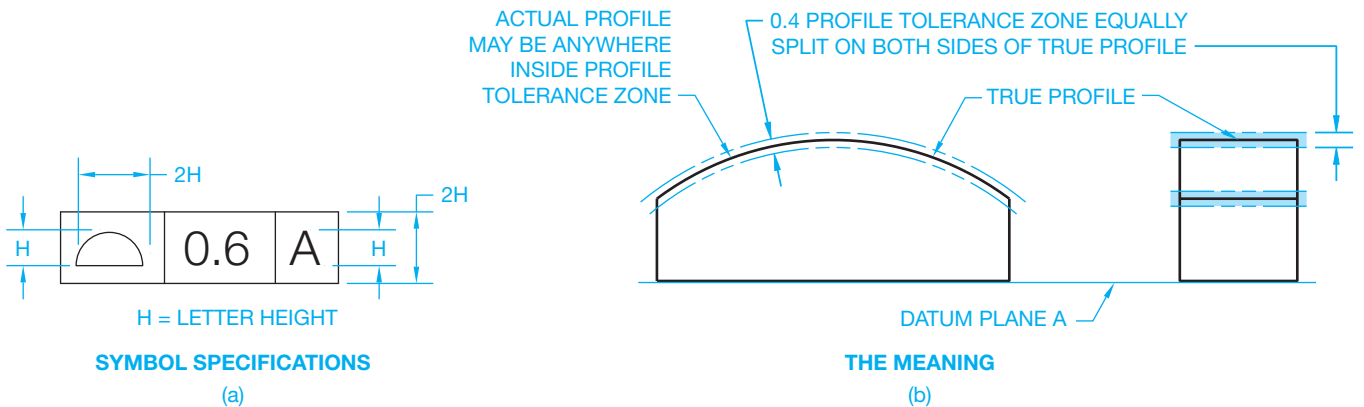
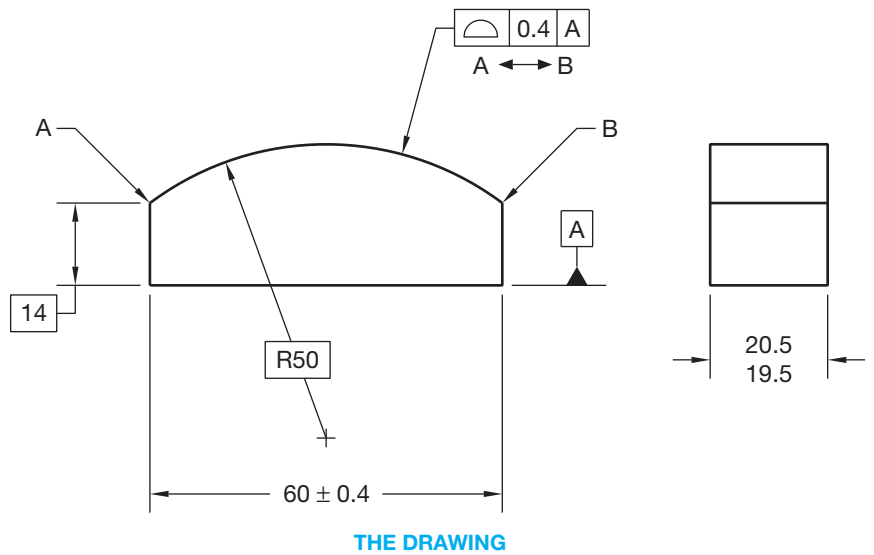
When a unilateral profile tolerance is required, the unequally disposed symbol is placed after the geometric tolerance in the feature control frame as shown in Figure 13.98a. When the unilateral profile tolerance has material added to the feature or part, the profile tolerance value is repeated after the unequally disposed symbol. The feature control frame is connected to the edge view of the surface with a leader line. This is the preferred ASME Y14.5 use for this application.

When the unilateral profile tolerance is inside the true profile, the profile tolerance value is placed before the unequally disposed



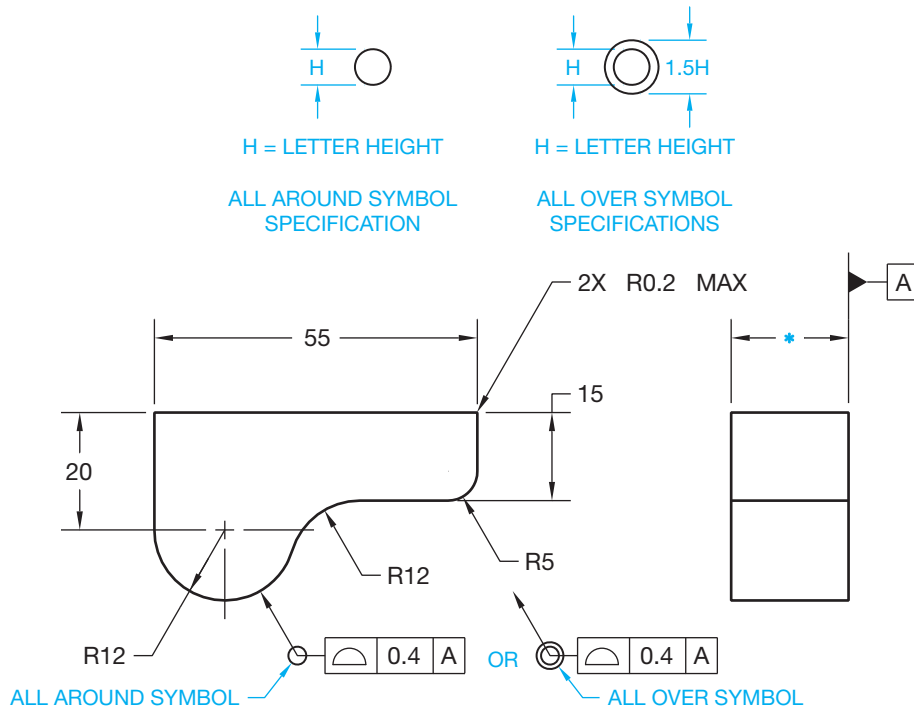
© Cengage Learning 2012

**FIGURE 13.95** An alternate method for specifying a unilateral profile tolerance uses a phantom line to indicate how the intended profile tolerance applies to true profile.



© Cengage Learning 2012

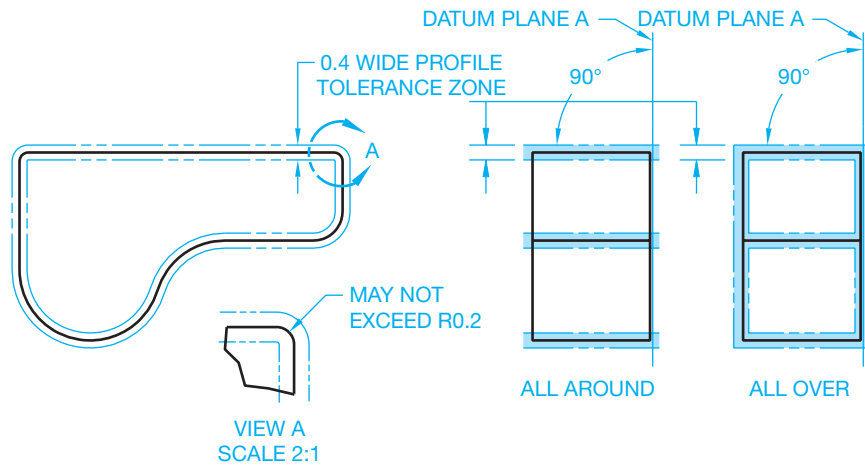
**FIGURE 13.96** (a) A feature control frame with the profile of a surface geometric characteristic symbol and datum reference. (b) A profile of a surface tolerance specified between two points.



NOTE: UNTOLERANCED DIMENSIONS ARE BASIC.

\* TOLERANCE DIMENSION USED FOR ALL AROUND.  
BASIC DIMENSION USED FOR ALL OVER.

THE DRAWING



THE MEANING

FIGURE 13.97 Using a profile of a surface tolerance all around or all over.

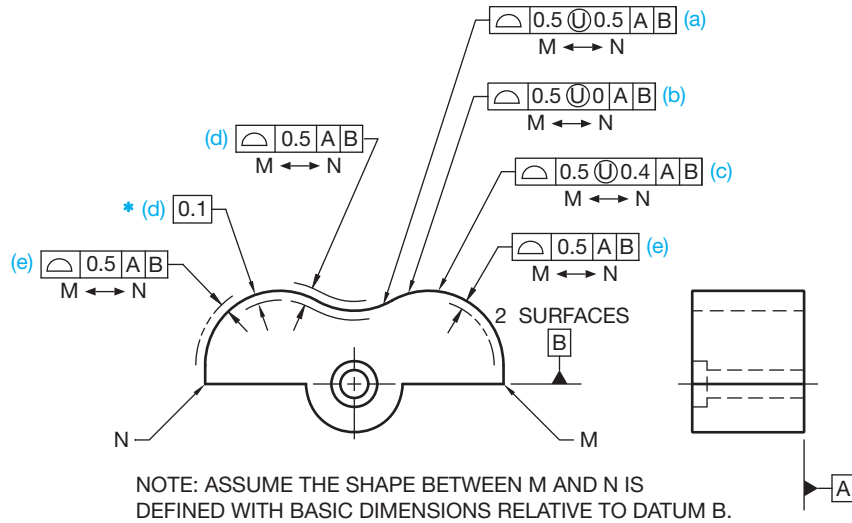
© Cengage Learning 2012

symbol and a 0 is placed after the unequally disposed symbol to denote that the entire profile tolerance has less material taken from the feature or part. The feature control frame is connected to the edge view of the surface with a leader line as shown in Figure 13.98b. This is the preferred ASME Y14.5 use for this application.

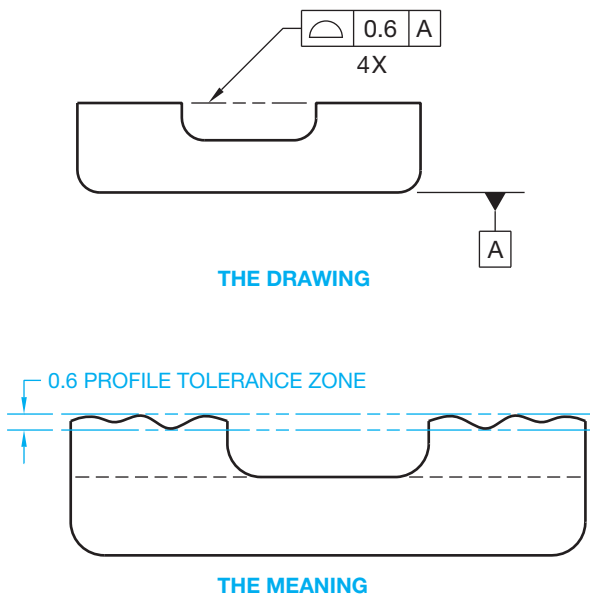
When the profile tolerance is not equally split on each side of true profile, the total profile tolerance value is placed before the unequally disposed symbol in the feature control frame, and

the value of the tolerance that adds material to the feature or part is placed after the unequally disposed symbol. The feature control frame is connected to the edge view of the surface with a leader line as shown in Figure 13.98c. This is the preferred ASME Y14.5 use for this application.

An alternate method used when the profile tolerance is unequally disposed displays the total tolerance inside the feature control frame. Either the inside or outside of true profile is



**FIGURE 13.98** Unilateral and unequally disposed profile of a surface tolerance application. (a) Applying the unilateral profile tolerance where the entire profile tolerance provides additional material to the feature or part. This is the preferred ASME Y14.5 use for this application. (b) Applying the unilateral profile tolerance where the entire profile tolerance removes material from the feature or part. This is the preferred ASME Y14.5 use for this application. (c) Applying an unequally disposed profile tolerance. This is the preferred ASME Y14.5 use for this application. (d) An alternate method when an unequally disposed profile tolerance is required uses a basic dimension to indicate where the tolerance zone is intended. (e) An alternate option when a unilateral profile tolerance is required uses a short phantom line on the side of the true profile to indicate where the tolerance zone is intended.



**FIGURE 13.99** An application of a coplanar profile tolerance. Note: A top view is also required to show and provide location and size dimensions to the four raised features.

shown as a basic dimension. Figure 13.98d shows the profile tolerance on the inside as a basic dimension of 0.1. The same result can be achieved by showing a basic dimension of 0.4 on the outside. One or the other must be dimensioned to show which way the tolerance applies and how much profile tolerance is allowed inside or outside. A dimension line with arrowheads is placed on each side of the phantom lines and connects the feature control frame with a leader. The basic dimension is required because the true profile is defined by basic dimensions, and the tolerance zone must also be defined as basic. The actual profile of the part must be between the basic zone created around the true profile.

An alternate option used when a unilateral profile tolerance is required is to draw a short phantom line on the side of the true profile where the unilateral tolerance zone is intended. The feature control frame is connected to the feature with a leader as shown in Figure 13.92e.

**NOTE:** Figure 13.98 shows six methods of applying profile tolerances. An actual drawing only shows one profile tolerance application. In actual practice, six drawings are required to represent the applications shown in Figure 13.98a through Figure 13.98e.

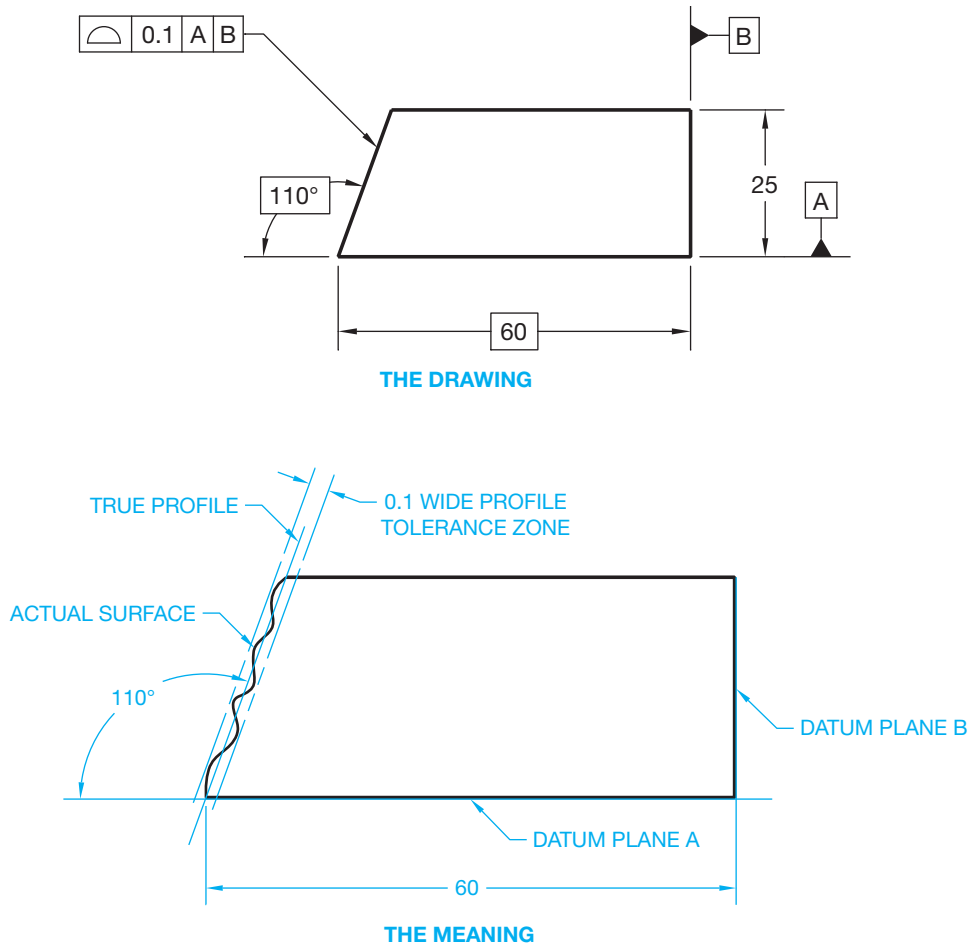


FIGURE 13.100 Specifying the profile of an inclined planar surface.

© Cengage Learning 2012

### Profile of Coplanar Surfaces

Coplanar surfaces are two or more surfaces on a part that are on the same plane. A **coplanar profile** tolerance can be used when it is desirable to treat two or more separate surfaces, which lie on the same plane, as one surface. To control the profile of these surfaces as a single surface, place a phantom line between the surfaces in the view where the required surfaces appear as lines. Connect a leader from the feature control frame to the phantom line and add a note below the feature control frame identifying the number of surfaces. Refer to the note 4× shown in Figure 13.99. The drawing shown in Figure 13.99 can also have the surfaces controlled with a flatness geometric tolerance without using a datum reference. When the feature control frame leader points to the phantom line, all of the surfaces are jointly controlled. For example, if there are a total of two additional raised surfaces behind the two that can be seen in the front view, then the note 4× is placed below the feature control frame. A top view is also required to provide dimensions to the four raised features.

When there are several coplanar surfaces, it can be desirable to establish two surfaces as datum planes with a common profile tolerance, such as the datum features labeled A and B on separate surfaces. Other coplanar surfaces can be controlled with a profile tolerance relative to both datums by placing the letters A-B in the feature control frame. The profile tolerance zone applies to all surfaces, including the datums. A note specifying the number of surfaces or the continuous feature symbol can be used.

### Profile of Plane Surfaces

Profile tolerancing can be used to control the form and orientation of **planar surfaces**. For example, profile of a surface can be used to control the angle of an inclined surface in relationship to a datum, as shown in Figure 13.100. Notice in Figure 13.100 that the required surface must lie between two parallel planes 0.1 mm apart and equally split on each side of a true plane that has a basic angular orientation to a datum.

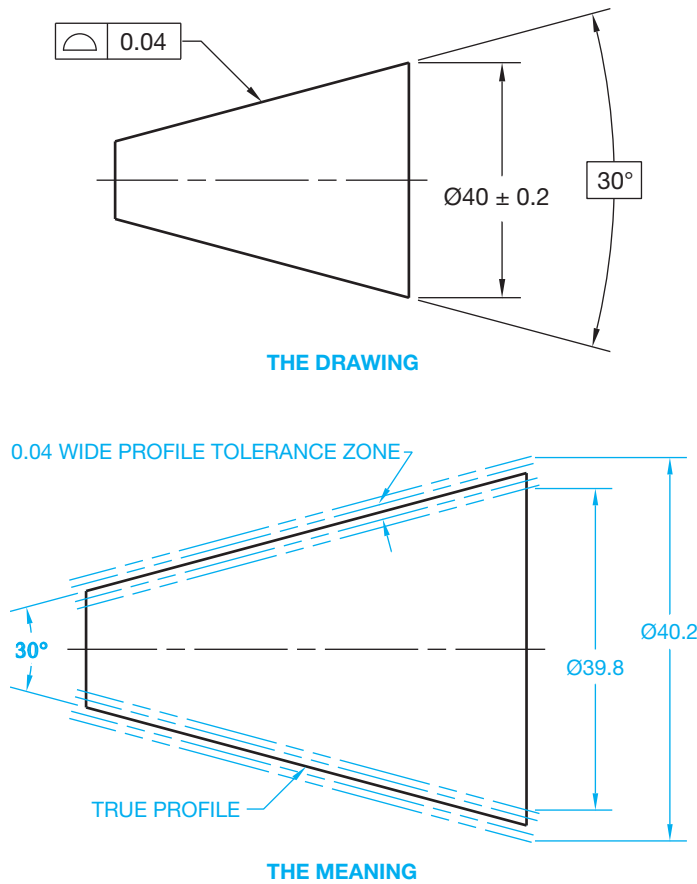


FIGURE 13.101 Specifying the profile of a conical feature. © Cengage Learning 2012

### Profile of Conical Features

A profile tolerance can be used to control the form, or form and orientation, of a conical surface. The feature can be controlled independently as a refinement of size or it can be oriented to a datum axis. In either case, the profile tolerance must be within the size tolerance. Conical profile requires that the actual surface lie between two coaxial boundaries equal in width to the specified geometric tolerance, having a basic included angle, and within the size limits. Coaxial means having the same axis (see Figure 13.101).

### Composite Profile Tolerance

A composite profile tolerance provides for the location of a profiled feature and, at the same time, the control of form and orientation. This is done by doubling the height of the feature control frame that points to the feature to be controlled. The profile geometric characteristic symbol is placed in the first compartment. The top half of the feature control frame is called the **locating tolerance zone**. This is the profile tolerance that locates the feature from datums. The related datum reference is given in the order of precedence in the feature control frame, and the feature to be controlled is located from datums with basic dimensions. The bottom half of the feature control

frame is called the **profile form and orientation tolerance zone**. Datum referencing in the lower area establishes the limits of size, form, and orientation of the profile related to the locating tolerance zone. The actual feature surface must be within both tolerance zones as shown in Figure 13.102.

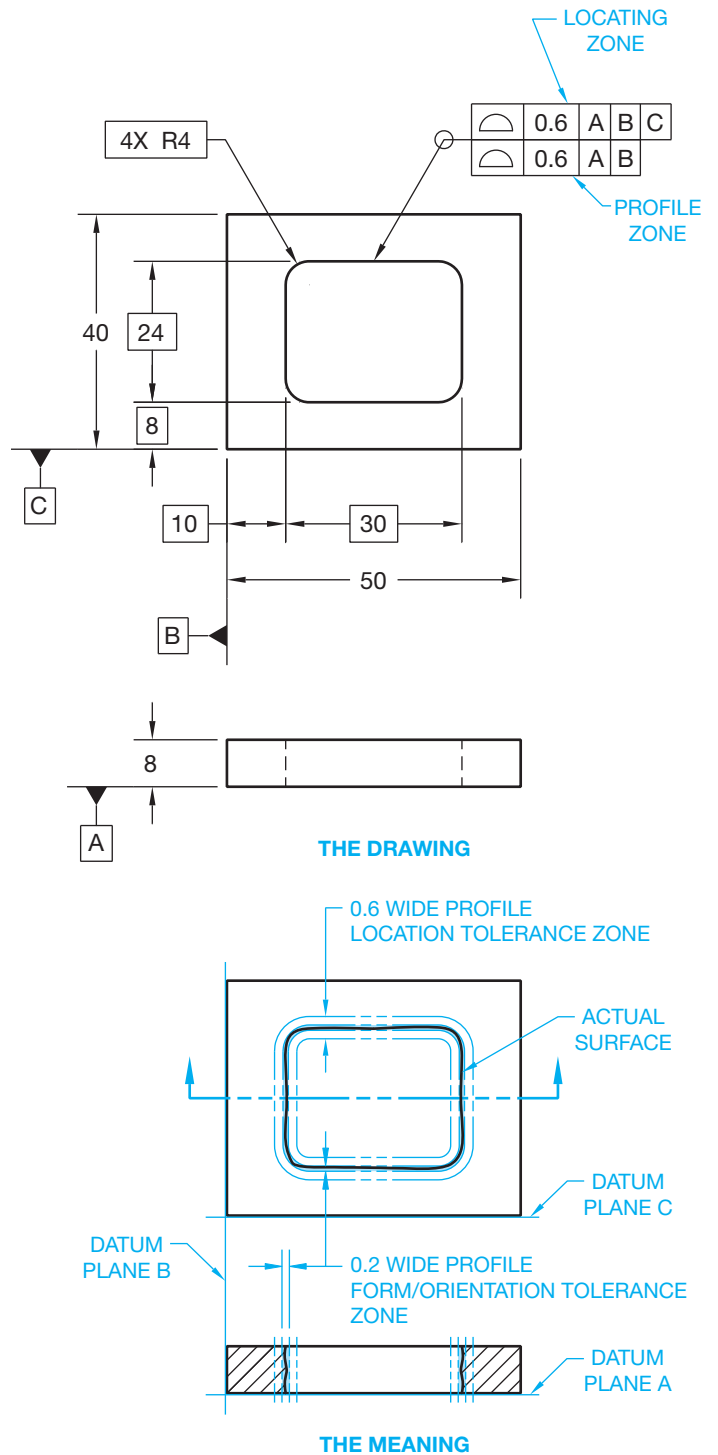


FIGURE 13.102 A composite profile tolerance provides for the location of a profiled feature and, at the same time, the control of form and orientation. © Cengage Learning 2012

## Profile of a Feature to Be Restrained

When any geometric tolerance is to be verified with the part in a restrained condition, the features to be used as datum features must be identified. It may also be necessary to specify the force required to restrain the part by placing a note such as THIS TOLERANCE APPLIES WHEN DATUM FEATURE A IS MOUNTED AGAINST A FLAT SURFACE USING FOUR M6×1 BOLTS TORQUED TO 9-15 N·m under the feature control frame, which specifies the process used and the force required to restrain the part.

## Combining Profile with Other Geometric Tolerances

Profile tolerancing can be combined with other types of tolerancing. For example, a surface can have a profile tolerance controlled within a specified amount of parallelism relative to a datum. When this is done, the surface must be within the profile tolerance, and each line element of the surface must be parallel to the given datum by the specified parallelism tolerance.

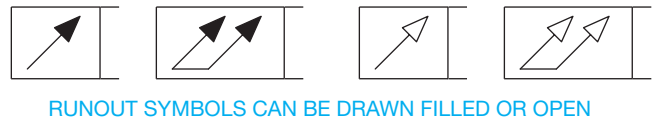
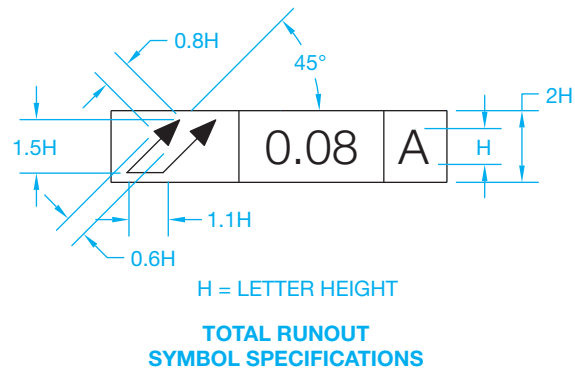
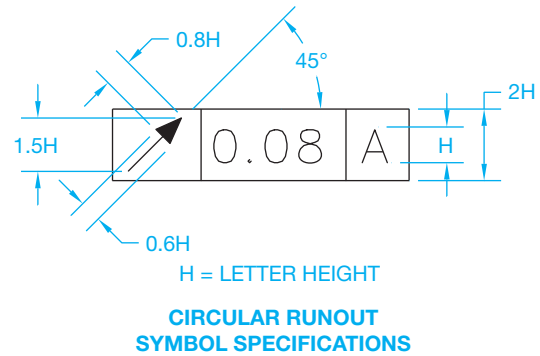
## RUNOUT GEOMETRIC TOLERANCE

This section covers the concepts and techniques of dimensioning and tolerancing to control the **runout** of geometric shapes. Runout is a combination of controls that can include the control of circular elements of a surface; the control of the cumulative variations of circularity, straightness, coaxiality, angularity, taper, and profile of a surface; and the control of variations in perpendicularity and flatness.

Runout is a combination of geometric tolerances used to control the relationship of one or more features of a part to a datum axis. Features that can be controlled by runout are either surfaces constructed around, or perpendicular to, a datum axis. The datum axis should be selected as a diameter of sufficient length, as two diameters adequately separated on the same axis, or as a diameter and perpendicular surface. Runout is always controlled on a RFS basis. Datum references are always RMB. There are two types of runout geometric tolerances: **total runout** and **circular runout**. The type of runout selected depends on design and manufacturing considerations. Circular runout is generally a less complex requirement than total runout. The feature control frame is connected by a leader line to the surface. Multiple leaders can be used to direct a feature control frame to two or more surfaces having a common runout tolerance. The runout geometric characteristic symbols are shown detailed in feature control frames in Figure 13.103.

### Circular Runout

Circular runout provides control of single circular elements of a surface. When applied to surfaces constructed around or

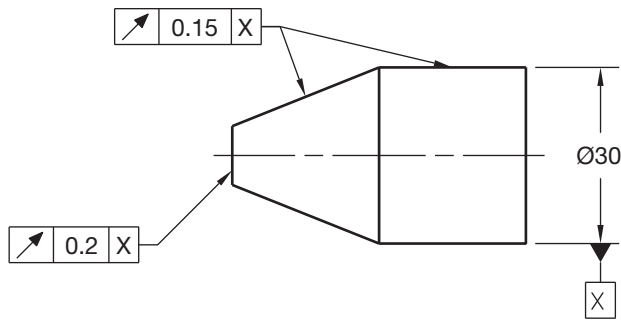


**FIGURE 13.103** Feature control frames with the circular and total runout geometric characteristic symbols and datum references. The runout symbol arrows may be filled or unfilled, depending on company preference.

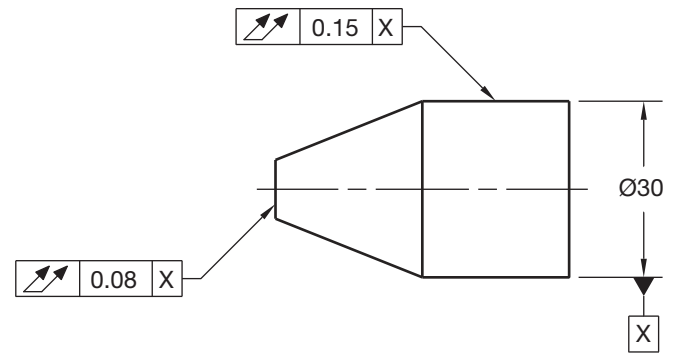
perpendicular to a datum axis, circular runout controls circularity and coaxiality. Coaxiality is a condition in which two or more features share a common axis. When applied to surfaces at right angles to a datum axis, circular runout can be used to control wobbling motion. This tolerance is measured by the full indicator movement (FIM) of a dial indicator placed at several circular measuring positions as the part is rotated 360°. FIM shows a total tolerance. Each circular element must lie within the FIM. FIM is also referred to as *total indicator reading* (TIR). To establish the datum axis for runout inspection, the part is held in a clamping device, such as a **collet**. A collet is a cone-shaped chuck used for holding cylindrical pieces in a lathe or inspection machine. An example of circular runout is shown in Figure 13.104. The controlling datum must be verified before other surfaces are checked. The circular runout reference datum is always regardless of material boundary.

### Total Runout

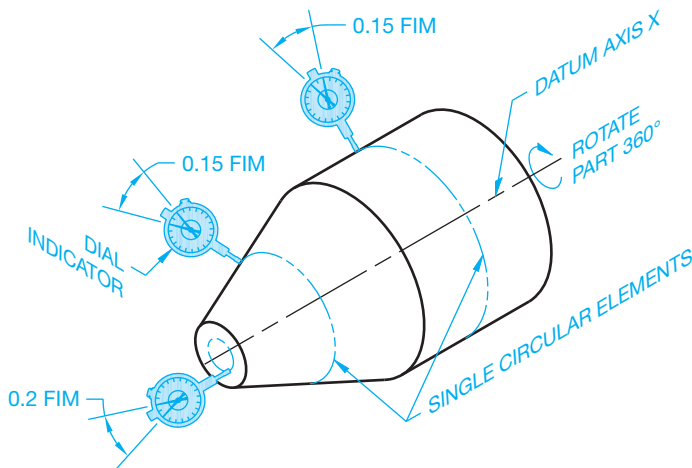
Total runout provides a combined control of surface elements. This is a tolerance that blankets the surface to be controlled.



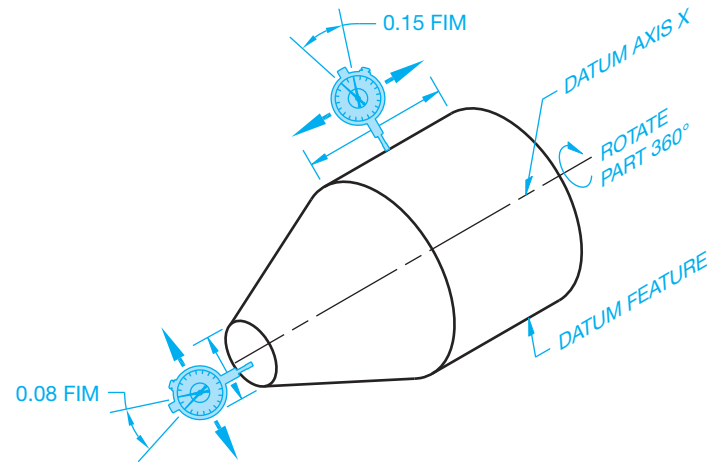
THE DRAWING



THE DRAWING



THE MEANING



THE MEANING

FIGURE 13.104 The application of circular runout. © Cengage Learning 2012

FIGURE 13.105 The application of total runout. *Note:* The angled feature on this part cannot be controlled with total runout. The indicator reading would never be within limits. The angled surface can only be controlled with circular runout. © Cengage Learning 2012

Total runout is used to control the combined variations of circularity, straightness, coaxiality, angularity, taper, and profile when applied to surfaces constructed around and at right angles to a datum axis. The reference datums are always regardless of material condition.

Total runout can be used to control the combined variations of perpendicularity (to control wobble and flatness) and to control concavity or convexity when applied to surfaces perpendicular to a datum axis. The total runout tolerance zone encompasses the entire surface as the part is rotated 360°. The entire surface must lie within the specified tolerance zone. To determine this, the dial indicator is placed at every location along the surface as the part is rotated 360°. Total runout is shown in Figure 13.105.

### Applying Runout to a Portion of a Surface and Two Datum References

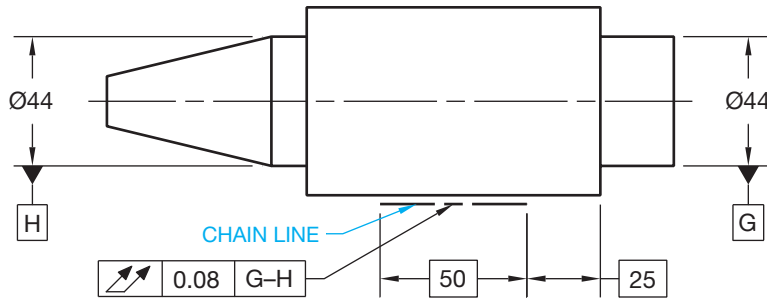
A portion of a surface can have a runout tolerance specified if it is not desired to control the entire surface. This is done by placing a chain line located with basic dimensions in the linear view. The chain line identifies where the runout

tolerance around the object is located. The feature control frame is then connected by a leader to the chain line. Runout tolerances can also be applied where two datum diameters collectively establish a single datum axis. This is done by placing the datum identifying letters, separated by a dash, in the feature control frame, such as G-H is used on the drawing in Figure 13.106.

### Applying Runout to a Datum Surface and a Datum Axis

Runout geometric tolerances can be controlled in relationship to a datum axis and a surface at right angles to the axis. When this is done, the datums are placed separately in the feature control frame in their order of precedence. Each circular element for circular runout or each surface (for total runout) must be within the specified geometric tolerance when the part is mounted on the datum surface and rotated 360° about the datum axis. The datum reference is always





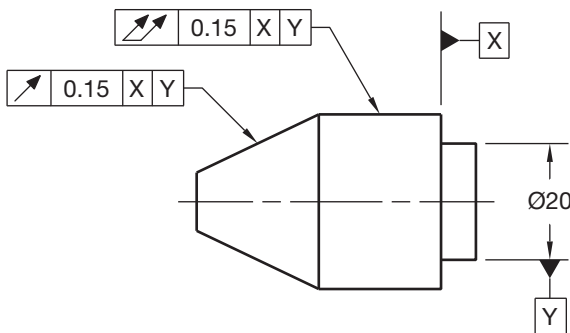
© Cengage Learning 2012

**FIGURE 13.106** Using partial surface runout and specifying runout to two datum references established collectively.

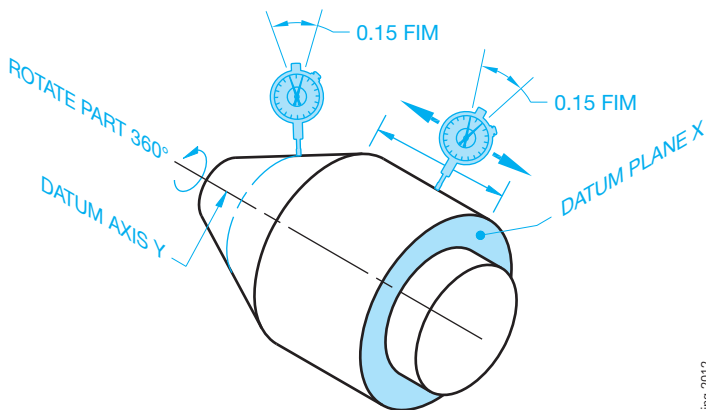
specified on a regardless of material boundary basis (see Figure 13.107).

### Applying Runout Control to a Datum

When a datum feature symbol is specified on a runout control, the runout geometric tolerance applies to the datum feature. This is done by centering the datum feature symbol below the



**THE DRAWING**



**THE MEANING**

© Cengage Learning 2012

**FIGURE 13.107** Specifying runout to a datum surface and a datum axis.

feature control frame or connecting the datum feature symbol to the leader shoulder of the leader connected to the feature control frame.

### Combining Runout with Other Geometric Tolerances

Runout tolerancing can be combined with other types of tolerancing. For example, a surface can be controlled by profile and refined by runout. When this is done, any line element of the surface must be within the profile tolerance, and any circular element of the surface must be within the specified runout tolerance.

Sometimes it may be necessary to control runout constrained by flatness, straightness, or cylindricity. A combination of runout and cylindricity means that the surface must be controlled within the specified tolerances of runout and cylindricity. The feature control frame for each geometric tolerance can be placed separately on the view where they apply to the related feature, or the feature control frame can be doubled in height with the runout specification in the top and the other geometric characteristic specification in the lower frame when applied to the same feature.

### SPECIFYING INDEPENDENCY

Rule 1 of ASME Y14.5 states that the limits of size of a regular feature of size controls form, such as straightness, flatness, circularity, and cylindricity. This means that the form of the feature is dependent on the limits of size. This rule can be overridden by the use of the independency symbol, as shown in Figure 13.108. Rule 1 can be impractical on a feature of significant length that has a tight size tolerance. When the independency symbol is used, the form control is independent of the size tolerance, and a form control should be added to the feature. Without the independency symbol, the form of the  $\varnothing 10 \pm 0.02$  feature in Figure 13.102 is completely dependent on the size tolerance. With the independency symbol used, the size is verified by a two-point check using a micrometer or caliper, and the form is checked using the runout tolerance. In this case, the runout checks straightness and circularity of the feature.

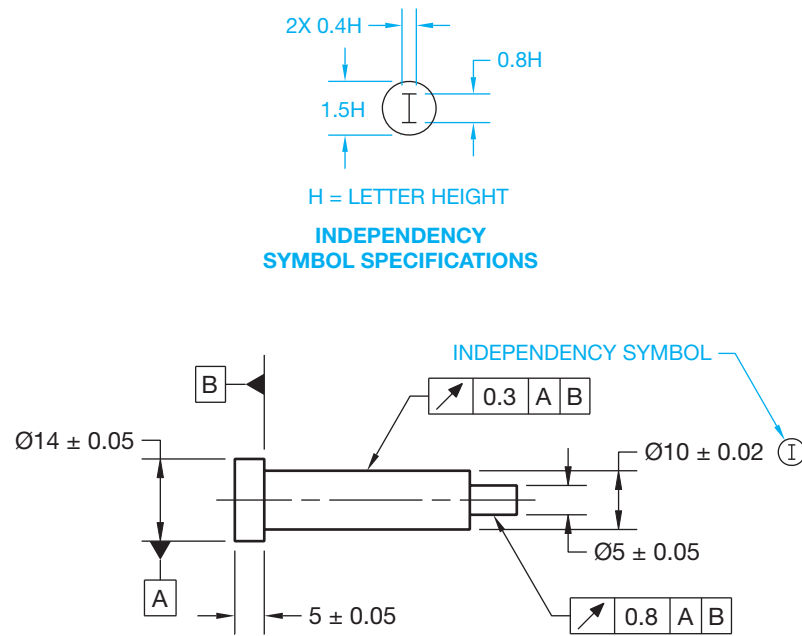


FIGURE 13.108 Specifying independency to a feature of size.

## GD&T WITH CADD

CADD allows you to quickly and accurately place and edit GD&T symbols. To add GD&T content to a CADD drawing, study the CADD system you intend to use for proper technique and refer to this textbook to determine correct size, format, and use of ASME Y14.5-2009 symbols. CADD drawings include representations of features drawn as objects or extracted from CADD model data. Features typically appear on a drawing in a nominal or basic state, with size and location parameters stored in a database. You add dimensional information and GD&T symbols to represent specific dimensioning and GD&T requirements. CADD automates the process of dimensioning and tolerancing features, but you are responsible for using correct drafting practices and software tools and techniques.

The process of adding GD&T symbols to a CADD drawing varies, depending on the software, tools and options used to generate symbols, and the purpose of the symbols. You may have to select points or objects, type or choose values, or build symbols from scratch. Basic CADD programs or uncommon dimensioning and GD&T applications require that you construct symbols using line, shape, text, and attribute tools. Software that is more powerful, such as AutoCAD, includes specific tools for adding some GD&T symbols, such as feature control frames. You must use other dimensioning tools and settings, object and text construction methods, and symbol functions to describe GD&T information completely. Mechanical design and drafting centered CADD systems

such as Autodesk AutoCAD Mechanical, Autodesk Inventor, Dassault Systèmes SolidWorks, PTC Pro/ENGINEER, and Siemens Corporation NX and SolidEdge provide more comprehensive GD&T tools and symbols. Third-party add-ins with additional GD&T symbols are also available for some programs.

Though CADD and specialized GD&T tools and symbols significantly improve accuracy and productivity, it is your responsibility to correctly apply drafting practices and comply with the ASME Y14.5 drafting standard. You may find that your CADD system does not provide specific GD&T tools, or it does not allow you to apply certain GD&T symbols according to ASME Y14.5-2009 easily. As a result, you must set up or modify specific dimension styles and system standards and variables. In addition, to document certain GD&T applications, you may have to construct symbols, modify available symbols, or customize the software.

## GD&T GUIDELINES FOR CADD/CAM

The following is a list of GD&T guidelines for use in conjunction with CADD/CAM that are partly taken from ASME Y14.5:

- Major features of the part should be used to establish the basic coordinate system but are not necessarily defined as datums.
- Subcoordinated systems that are related to the major coordinates are used to locate and orient features on a part.

(Continued)

- Define part features in relation to three mutually perpendicular reference planes and along features that are parallel to the motion of CAM equipment.
- Establish datums related to the function of the part and relate datum features in order of precedence as a basis for CAM usage.
- Completely and accurately dimension geometric shapes. Regular geometric shapes may be defined by mathematical formulas; although a profile feature that is defined with mathematical formulas should not have coordinate dimensions unless required for inspection or reference.
- Coordinate or tabular dimensions should be used to identify approximate dimensions on an arbitrary profile.
- Use the same type of coordinate dimensioning system on the entire drawing.
- Continuity of profile is necessary for CADD. Clearly define contour changes at the change or point of tangency. Define at least four points along an irregular profile.
- Circular hole patterns may be defined with polar coordinate dimensioning.
- When possible, dimension angles in degrees and decimal parts of degrees; for example,  $45^{\circ} 30' = 45.5^{\circ}$ .
- Base dimensions at the mean of a tolerance because the numerical control (NC) programmer will normally split a tolerance and work to the mean. Establish dimensions without limits that conform to the NC machine capabilities and part function where possible. Bilateral profile tolerances are also recommended for the same reason.
- Geometric tolerancing is necessary to control specific geometric form and location, but it is not required if general tolerancing provides sufficient form or location control.
- The standard ASME Y14.5.1, *Mathematical Definition of Y14.5*, is the mathematical model of all specifications found in ASME Y14.5. This allows for convenient digitizing of a part so that all gaging is in a CADD system.

## GD&T WITH AUTOCAD

AutoCAD allows you to add GD&T symbols to drawings using the TOLERANCE, MLEADER, and QLEADER commands. The TOLERANCE command displays the Geometric Tolerance dialog box, which is the primary method for adding feature control frames, geometric tolerancing, and datum target symbols. You can also connect GD&T symbols to a leader using a combination of the TOLERANCE and MLEADER commands. The MLEADER command has replaced the QLEADER command as the primary method for placing leaders. However, the QLEADER command continues to provide a quick and effective option for automatically attaching GD&T symbols to a leader.

Another option for placing GD&T symbols is to create your own blocks with attributes. You can insert blocks into the drawing and adjust the attribute data as needed. You can also add blocks to multileader lines using the Block multileader content type. Draw GD&T symbols on a dimensioning layer so the symbols and text can plot as lines that have the same thickness as extension and dimension lines (.01 in. or 0.3 mm). The suggested text font is RomanS. These practices correspond with the standard ASME Y14.2M-1992, *Line Conventions and Lettering*.

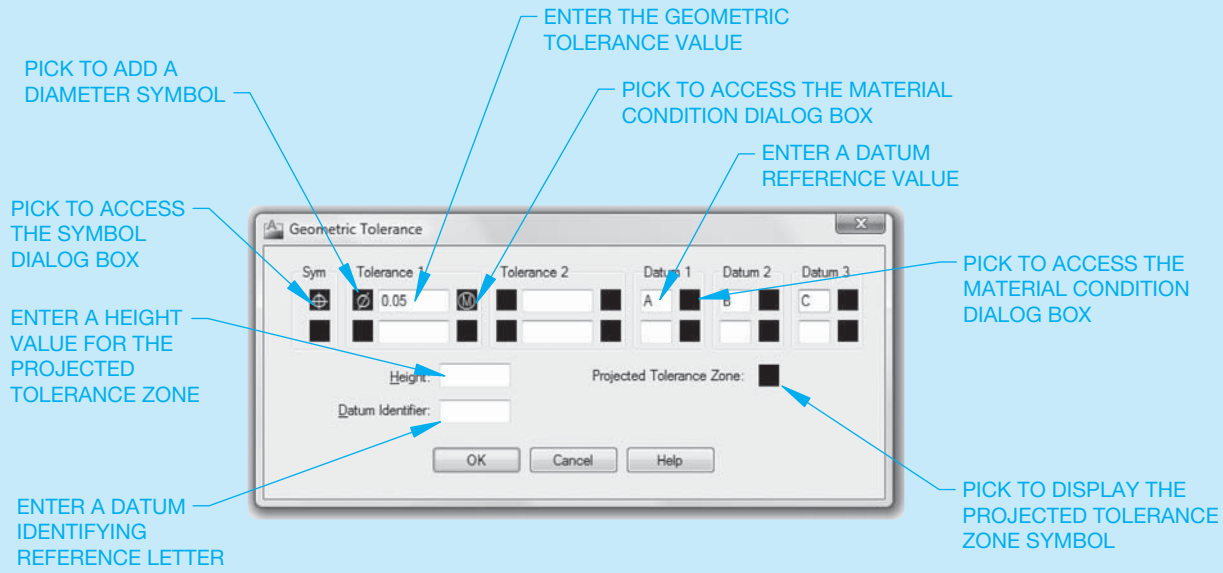
### Drawing Feature Control Frames

The TOLERANCE command provides options for creating feature control frames using the Geometric Tolerance

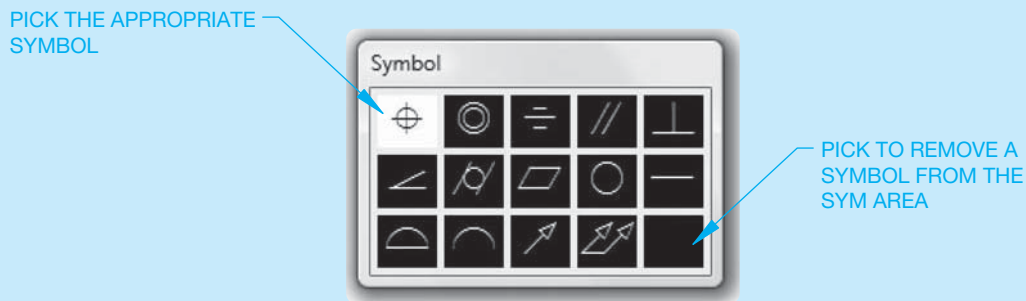
dialog box (see Figure 13.109). Areas divide the Geometric Tolerance dialog box into groups of compartments that relate to the components found in a feature control frame. Each area contains two levels to define a feature control frame. The first, or upper, level allows you to make a single feature control frame. The lower level allows you to add data to create a double feature control frame. Several GD&T applications require that you double the feature control frame in height, with two sets of geometric tolerancing values provided. The dialog box also provides options for displaying a diameter symbol and a modifying symbol. In addition, the Geometric Tolerance dialog box allows you to display a projected tolerance zone symbol and value and part of the datum feature symbol.

Figure 13.110 shows the Symbol dialog box that appears when you pick a box in the Sym area. Select the appropriate geometric characteristic symbol to add the symbol to the selected Sym box. A composite frame forms when the symbols in the two Sym boxes are the same. Some situations require the same geometric characteristic symbol twice, one in the upper frame and another in the lower frame. To create these two single-segment feature control frames, draw two separate feature control frames and block them. If drawing a double feature control frame with different geometric characteristic symbols for a combination control, the feature control frame must have two separate compartments.

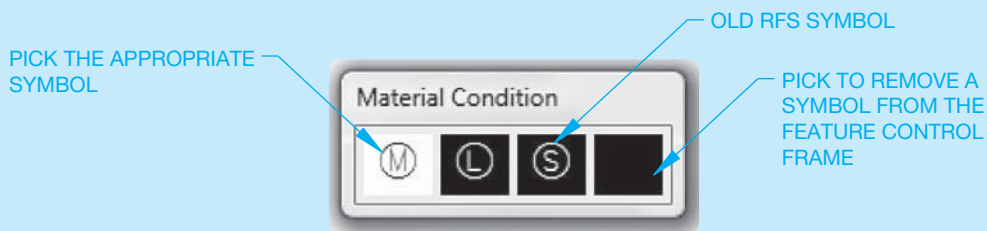
(Continued)



**FIGURE 13.109** You can use the AutoCAD Geometric Tolerancing dialog box to draw feature control frames and datum feature symbols.



**FIGURE 13.110** Use the Symbol dialog box to select a geometric characteristic symbol for use in the feature control frame.



**FIGURE 13.111** The Material Condition dialog box. Notice that the symbol for RFS is available. ASME Y14.5-2009 does not use this symbol, but you may need it when editing older drawings.

Pick the box to the left of the Tolerance 1 and Tolerance 2 area text boxes to add a diameter symbol. Specify the geometric tolerance value using the text boxes in the Tolerance 1 and Tolerance 2 areas. Figure 13.111 shows the Material Condition dialog box that appears when you pick the box to the right of the Tolerance 1 and Tolerance 2 area text boxes. Select the appropriate material condition symbol to add the symbol to the selected box. Use the datum 1,

datum 2, and datum 3 areas to establish the information needed for the primary, secondary, and tertiary datum references. You can also specify a material condition symbol for the datum reference by picking the box to the right of the corresponding text box to open the Material Condition dialog box shows in Figure 13.111. The remaining items in the Geometric Tolerance dialog box are described later

(Continued)

in this chapter. Pick the OK button and specify a point to place the feature control frame in the drawing.

### Attaching Feature Control Frames to Leaders

The QLEADER command allows you to draw leader lines and access the Geometric Tolerance dialog box used to create feature control frames in one operation. This is the most effective technique for creating a feature control frame automatically attached and associated with a leader. Select the Tolerance radio button in the Leader Settings dialog box that appears when you access the QLEADER tool (see Figure 13.112).

You can use the MLEADER command to create leaders, but it does not have an option to create a feature control frame at the same time. As a result, you must draw the leader separately using the MLEADER command and the feature control frame using the TOLERANCE command. Apply the None multileader content type when using this method. You can draw the leader before or after the symbol.

### Editing Feature Control Frames

A feature control frame acts as one object. The entire object selects when you pick any location on the frame. You can edit feature control frames using editing commands such as ERASE, COPY, MOVE, ROTATE, and SCALE. The STRETCH command only allows you to move a feature control frame. This effect is similar to the results of using the STRETCH command with text objects. You can edit the values inside a feature control frame using the DEDIT command.

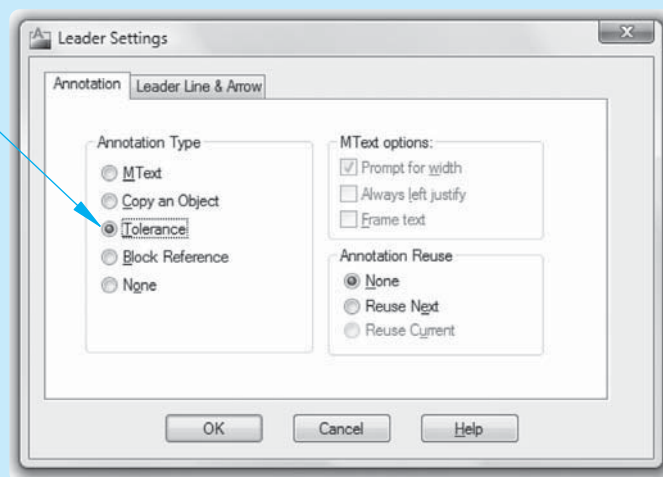
### Drawing a Projected Tolerance Zone

The TOLERANCE command and Geometric Tolerance dialog box allows you to specify projected tolerance zones according to the ASME Y14.5M-1982 standard by adding a projected tolerance zone symbol to the Projected Tolerance Zone: box and the projected tolerance zone height in the Height text box. To specify a projected tolerance zone according to ASME Y14.5-2009, create a feature control frame with any modifier letters and the letter P after the tolerance value. Type the height of the projected tolerance zone after the P, leaving one space between each letter and the height value. Then use the CIRCLE command to draw a circle around the modifier and the letter P (see Figure 13.113). You can use the BLOCK command to group the feature control frame and circles so they are selectable as a single object.

### Drawing Datum Feature Symbols

You can draw datum feature symbols using the TOLERANCE and MLEADER or QLEADER commands. Usually, however, you must use a combination of TOLERANCE and MLEADER or QLEADER commands to draw an appropriate datum feature symbol. The method used to draw a datum feature symbol depends on the feature the symbol identifies. When you use the Geometric Tolerance dialog box to specify a datum feature symbol, enter the datum reference letter in the Datum Identifier: text box (see Figure 13.109).

ACTIVATE THE TOLERANCE OPTION



**FIGURE 13.112** The Leader Settings dialog box. Activate the Tolerance radio button to place a feature control frame.

© Cengage Learning 2012

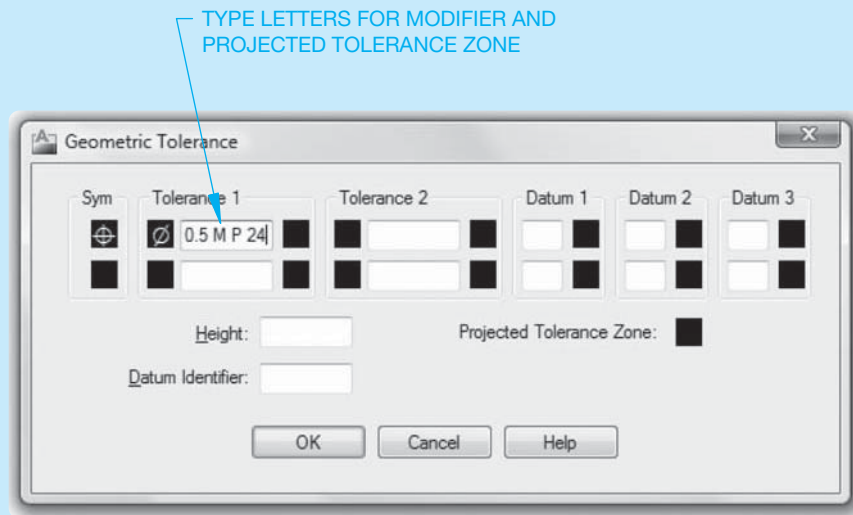
(Continued)

The datum feature symbols shown in Figure 13.114a are drawn using the TOLERANCE and MLEADER or QLEADER commands. One option is to use the TOLERANCE command first to place the datum identifier and then add a leader that connects the feature to the identifier. The other option is to draw a leader first and then use the TOLERANCE command to add the datum identifier. This usually requires you to move the datum identifier to the correct location using object snaps.

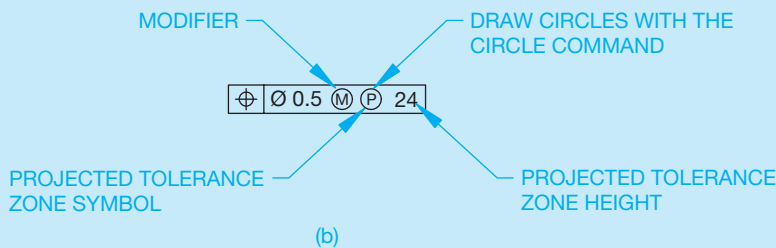
When you use the MLEADER command to add the leader, create a separate multileader style with a datum triangle filled arrowhead symbol, set the maximum leader points to 2, do not include a landing, and use the None multileader content type. When you use the QLEADER command to add the leader, create a dimension style that uses the datum triangle filled leader, use the None annotation type, and set the maximum leader points to 2. When a datum feature symbol requires a shoulder, add the should-

er manually by picking a third point. This avoids shifting the angle of the leader line.

You must follow specific steps in order to add a datum feature symbol to an angled surface, as shown in Figure 13.114b. One option is to use the QLEADER command. Before adding the leader, create a dimension style that uses the datum triangle filled leader. Then enter the QLEADER command and use the Settings option to open the Leader Settings dialog box. Select the Annotation tab and pick the Tolerance radio button. Select the Leader Line & Arrow tab of the Leader Settings dialog box and pick the Straight radio button. When adding a datum feature to a leader line, you should set the maximum number of vertices in the Maximum text box of the Number of Points area to 3. This allows you to construct the leader shoulder manually. If you let AutoCAD form the leader shoulder automatically, it shifts the angle of the leader line.



(a)



(b)

© Cengage Learning 2012

**FIGURE 13.113** (a) Using the Geometric Tolerance dialog box to specify a projected tolerance zone in accordance with ASME Y14.5-2009. To add projected tolerance zone specifications in accordance with ASME Y14.5-1982, enter the projected tolerance zone height in the Height text box and pick the Projected Tolerance Zone box. (b) Final feature control frame.

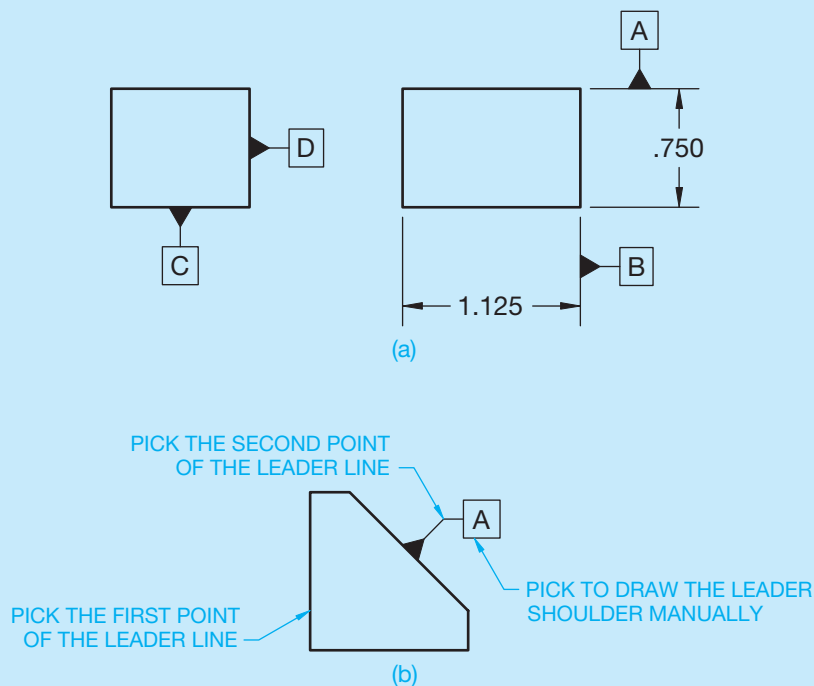
(Continued)

Select the OK button to exit the Leader Settings dialog box. Pick the leader start point and then the next leader point. The second point must create a line segment that is perpendicular to the angled surface. Pick the third point to define the length of the leader shoulder. If the maximum number of leader points is set to 3, the Geometric Tolerance dialog box displays. Otherwise, press [Enter] to end the leader line and display the Geometric Tolerance dialog box. Specify a value in the datum identifier text box and pick the OK button.

### Drawing Basic Dimensions

You can draw basic dimensions automatically by setting a basic tolerance in the Tolerances tab of the Modify Dimension Style dialog box. Typically, you establish

a separate dimension style for basic dimensions because not all of the dimensions on a drawing are basic. The Offset from dim line: setting in the Text tab of the New (or Modify) Dimension Style dialog box controls the distance from the text to the basic dimension rectangle. The setting also controls the gap between the dimension line and the dimension text for linear dimensions. Picking the Draw frame around text check box in the Text tab of the New (or Modify) Dimension Style dialog box also activates the basic tolerance method. Use the DDEDIT command to edit basic dimensions. Select the basic dimension for editing to display the mtext editor. You can then edit the basic dimension as you would any other dimension. If you double-click on a dimension object, AutoCAD opens the Properties palette.



**FIGURE 13.114** (a) Examples of datum feature symbols created using a combination of the TOLERANCE and MLEADER or QLEADER commands. (b) Use the Tolerance annotation option of the QLEADER tool to add a datum feature symbol to an angled surface.

## PROFESSIONAL PERSPECTIVE

Written By Michael A. Courtier,  
Supervisor/Instructor CAD/CAM/CAE Employee  
Training and Development, Boeing Aerospace

In working with engineers and drafters for years on the subject of geometric tolerancing, I find that questions keep popping up in several key areas—datums; limits of size; geometric tolerances as a refinement of size; the tolerance zones (2-D or 3-D, cylindrical or total wide, etc.); and the apparent overlap of controls (circularity, cylindricity, circular runout, total runout, position). It is in these weak spots that you should dig a little deeper and fill in your knowledge.

New and old users alike tend to miss the key rules of thumb in selecting datums, and most textbooks on the subject do not address this area:

Make sure you select datums that are real, physical surfaces of the part. I have seen many poor drawings with datums on centerlines, at the centers of spheres, or even at the center of gravity.

Be sure to select large enough datum surfaces. It is hard to chuck up on a cylinder 1/10 in. long, or get three noncolinear points of contact on a plane of similar dimensions.

Choose datums that are accessible. If manufacturing or quality assurance has to build a special jig to reach the datum, extra costs are incurred for the ultimate part.

Given the above constraints, select functional surfaces and corresponding features of mating parts where possible.

Remember, datums are the basis for subsequent dimensions and tolerances, so they should be selected carefully. You might also be well advised to assign a little form, orientation, or runout control to the datum surface to ensure an accurate basis.

In the area of limits of size, there are three possible interpretations of a size dimension. Every class I have taught has been divided on what the proper extent of a size dimension's control should be—the overall size (or geometric form), the size at various cross-sectional checks, or both. The correct answer, per definition in the standard, is *both*!

The words *refinement of size* are a source of general confusion to new users of geometric tolerancing. Let us say a part is dimensioned on the drawing as  $.500 \pm .005$  in. thick, with parallelism control to  $.003$  in. on the upper surface. If a production part has a convex upper surface with low points at  $.504$  in., then the high point can only be  $.505$  in., not  $.507$  in. In other words, only  $.001$  in. of the  $.003$  in. of parallelism control can be used since parallelism is a refinement of size within the overall size limits.

Another one of the often misunderstood aspects of geometric tolerancing is the tolerance zone. Many engineers,

technicians, drafters, machinists, and inspectors misinterpret the shape of the tolerance zone. I recommend that all new users make a chart showing the tolerance zones for each type of tolerance and a sampling of its various applications. This chart should include—at a minimum—the 2-D zones between two lines or concentric circles (such as straightness, circularity) versus the 3-D zones between parallel planes (such as flatness, perpendicularity); the cylindrical versus the total wide zones (for example, straightness to an axis versus surface straightness, or position of a hole versus position of a slot); the cross-sectional zones versus the total surface zones (such as circularity versus cylindricity); and many, many others. If you can properly visualize the tolerance zone, you are well on your way to the proper interpretation of the geometric tolerance.

One more thing to watch out for is the apparent overlap of controls. While it appears that there is overlap, there are subtle yet distinct differences between all the geometric tolerance controls. Consider cylindrical shapes, for instance. You can use a wide variety of controls for them, including straightness, circularity, cylindricity, concentricity, circular runout, total runout, and position, to name a few. Remember that the first three are form controls, so no datum relationship is controlled. Straightness can control the axis or the surface merely by placing the feature control frame in a different location on the drawing. Straightness is a longitudinal control, whereas circularity is a circular element control (both are 2-D); cylindricity is a 3-D control of the surface relative to itself (no datum). The last four controls are with respect to a datum (or datums), but they have their differences also. Concentricity and the runouts are always RFS, whereas positional tolerancing can be LMC or MMC and get bonus tolerances. Runout is a rotational consideration, while positional tolerancing does not imply rotation.

In summary, ASME Y14.5 is a very powerful tool for engineering drawings. Digging deep into the subtleties will separate the amateur from the professional, who knows it will save time and money in every discipline from design to manufacturing to quality assurance testing. Used properly, the engineering design team can convey more information about the overall design to downstream areas or subcontracting concerns that may have no knowledge of the final assembly. The proper assessment of the symbology requires no interpreter for the reader who is well versed in this international sign language called *geometric tolerancing*. Figure 13.115 is an example of an actual industry drawing. In general, the part is fairly basic, but the geometric tolerancing is very specific and leaves no doubt about the interpretation.



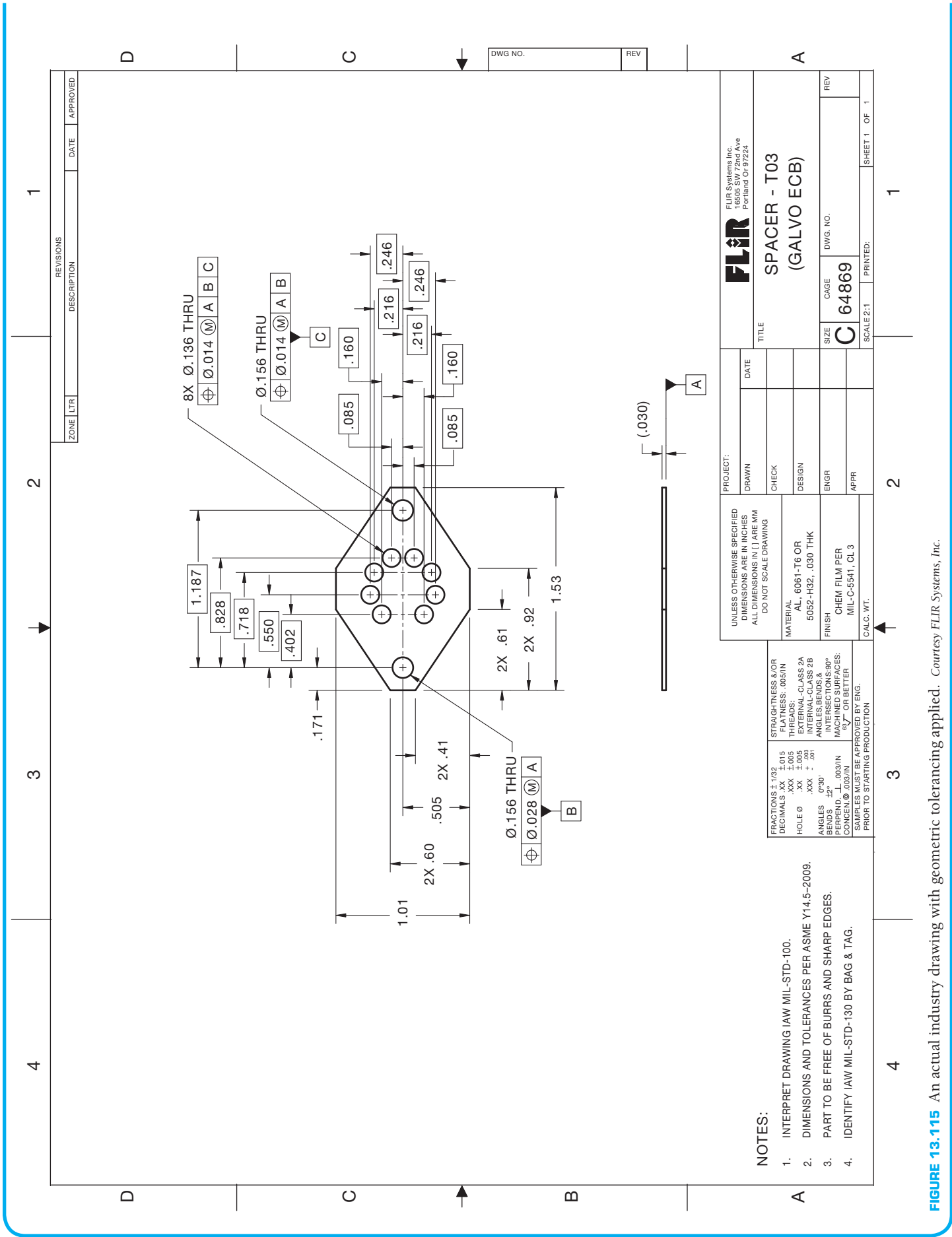


FIGURE 13.115 An actual industry drawing with geometric tolerancing applied. Courtesy FLIR Systems, Inc.

## ROUNDING NUMBERS

Calculators and computers usually indicate more precision in their answers than is warranted by the original data. The following is the mathematical convention for rounding calculations.

### When Adding or Subtracting

Round each figure to the coarsest (least precise) piece of data.

Do the arithmetic.

For example, to add the group  $4.39 + 7.9 + 6.42$ , first round each number to the nearest tenth (because of the 7.9) to get  $4.4 + 7.9 + 6.4$ . Then add to get the answer: 18.7.

### When Multiplying or Dividing

Do the arithmetic.

Round the answer to the least number of significant digits in the original data.

Digits are significant when they give information other than holding a decimal point in place. For example, 13.09 has four significant digits, but 13,000,000 has only two.

For example, to calculate  $13.78 \times 6.1 \times 4.385$ , first multiply; this gives 368.59433. Because the 6.1 has only two significant digits, round the answer to 370, which has only two significant figures (the zero of 370 being merely a placeholder).

When working with complicated formulas or when running computer programs, do not round off until the final answer is obtained. Constants in formulas are not considered data. When using a geometrical formula with in it, it is best to push the calculator's button instead of manually entering 3.14.



## Engineering Drawing and Design Math Applications

For complete information and instructions for engineering drawing and design math applications, go to the Student CD, select **Reference Material**, and then **Engineering Drawing and Design Math Applications**.

## WEB SITE RESEARCH

Use the following Web sites as a resource to help find more information related to engineering drawing and design and the content of this chapter.

Address	Company, Product, or Service
<a href="http://www.asme.org">www.asme.org</a>	American Society of Mechanical Engineers (ASME) ASME Y14.5M-2009, <i>Dimensioning and Tolerancing</i> standard
<a href="http://www.iso.org">www.iso.org</a>	International Organization for Standardization
<a href="http://www.adda.org">www.adda.org</a>	American Design Drafting Association and American Digital Design Association (ADDA International)
<a href="http://www.industrialpress.com">www.industrialpress.com</a>	Information about the <i>Machinery's Handbook</i> . This is a valuable resource for manufacturing standards, sizes, tolerances, fits, materials, and anything else you can think of for design and drafting.
<a href="http://www.industrialpress.com">www.industrialpress.com</a>	Online trigonometry tables
<a href="http://www.industrialpress.com">www.industrialpress.com</a>	Prime numbers and factoring information
<a href="http://www.g-w.com">www.g-w.com</a>	Search Products by Title, Textbook, Geometric Dimensioning and Tolerancing. <i>Geometric Dimensioning and Tolerancing</i> , by David A. Madsen and David P. Madsen. Comprehensive basic text workbook covering geometric dimensioning and tolerancing. Complete with tests, print reading exercises, drafting problems, ExamView test bank, and PowerPoint presentations.
<a href="http://www.amazon.com">www.amazon.com</a>	Search Books, Geometric Dimensioning and Tolerancing, find <i>Geometric Dimensioning and Tolerancing</i> by David A. Madsen and David P. Madsen.

## Chapter 13 Geometric Dimensioning and Tolerancing Test



To access the Chapter 13 test, go to the Student CD, select **Chapter Tests and Problems**, and then **Chapter 13**. Answer the questions with short, complete statements,

sketches, or drawings as needed. Confirm the preferred submittal process with your instructor.

## Chapter 13 Geometric Dimensioning and Tolerancing Problems

### INSTRUCTIONS

From the selected problems, determine which views and dimensions should be used to detail the part completely. Include all dimensions needed using unidirectional dimensioning.

1. Make a multiview sketch of the selected problem as close to correct proportions as possible. Be sure to indicate where you intend to place the dimension lines, extension lines, arrowheads, geometric tolerancing symbols, and hidden features to help you determine the spacing for your final drawing.
2. Using your sketch as a guide, make an original multiview drawing on an adequate size ASME-standard drawing sheet with border and sheet blocks. Use an appropriate scale.
3. When using solid modeling software, create the solid model using the given geometry and confirm the accuracy of the given engineering information as you proceed. Consult with your instructor or supervisor if you discover problems with the geometry and revise the drawings as needed to make the geometry accurate. Use your completed part solid models to develop fully dimensioned 2-D detail drawings. Place a 3-D model in the upper left corner of the drawing for use as a visualization aid.
4. Include the following general notes at the lower left corner of the sheet .5 in. each way from the corner border lines:

### NOTES:

1. DIMENSIONS AND TOLERANCES PER ASME Y14.5-2009.
2. REMOVE ALL BURRS AND SHARP EDGES.

Additional general notes may be required, depending on the specifications of each individual assignment. Use the following for tolerances for unspecified inch values. A tolerance block is recommended as described in Chapter 2.

UNSPECIFIED TOLERANCES	
DECIMALS	IN
X	$\pm 1$
XX	$\pm .01$
XXX	$\pm .005$
ANGULAR	$\pm 30'$
FINISH	125 $\mu\text{in.}$

For metric drawings, provide a general note that states TOLERANCES FOR UNSPECIFIED DIMENSIONS COMPLY WITH ISO 2768-m. Provide a general note that states SURFACE FINISH 3.2  $\mu\text{m}$  UNLESS OTHERWISE SPECIFIED.

Each problem assignment is given as an engineer's layout to help simulate actual drafting conditions. Dimensions and views on engineers' layouts may not be placed in accordance with acceptable standards. You need to review the chapter material carefully when preparing the layout sketch. In some problems, the engineer's layout assumes certain information, such as the symmetry of a part or the alignment of holes. You need to place enough dimensions or draw lines between features to dimension the part fully.



**Drafting Templates**

To access CADD template files with predefined drafting settings, go to the Student CD, select **Drafting Templates**, and then select the appropriate template file. Use the templates to create new designs, as a resource for drawing and model content, or for inspiration when developing your own templates. The ASME-Inch and ASME-Metric drafting templates follow ASME, ISO, and related mechanical drafting standards. Drawing templates include standard sheet sizes and formats and a variety of appropriate drawing settings and content. You can also use a utility such as the AutoCAD DesignCenter to add content from the drawing templates to your own drawings and templates. Consult with your instructor to determine which template drawing and drawing content to use.

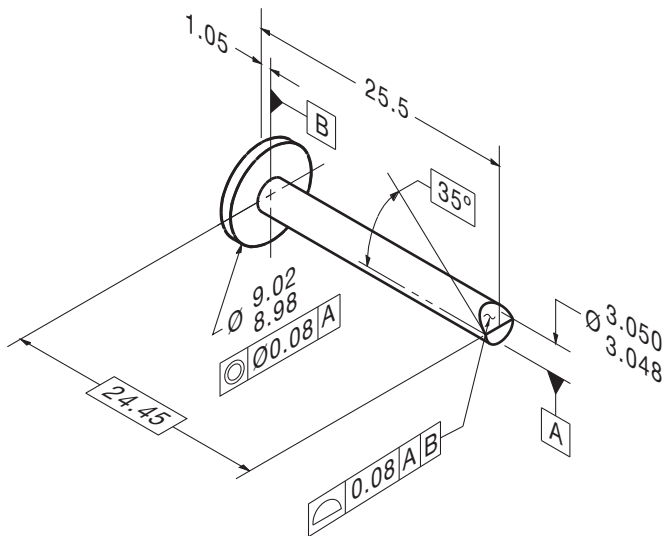
**Part 1: Problems 13.1 Through 13.15**

**PROBLEM 13.1 Geometric tolerancing (metric)**

Part Name: Flow Pin

Material: Bronze

Finish: Finish all over 0.20 μm.



© Cengage Learning 2012

**PROBLEM 13.2 Geometric tolerancing (metric)**

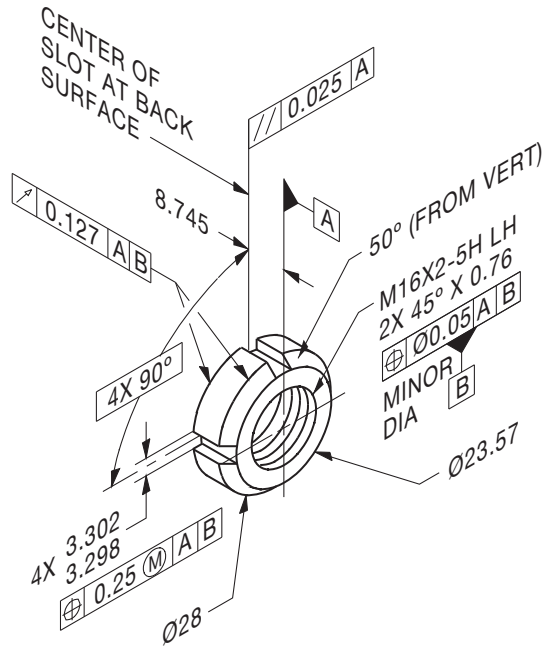
Part Name: LN2 Test Pump Lock Nut

Material: AMS 5732

Additional General Notes

⚠: Mark per AS478 Class D with 1193125 and applicable dash number.

Finish all over 1.6 μm.



© Cengage Learning 2012

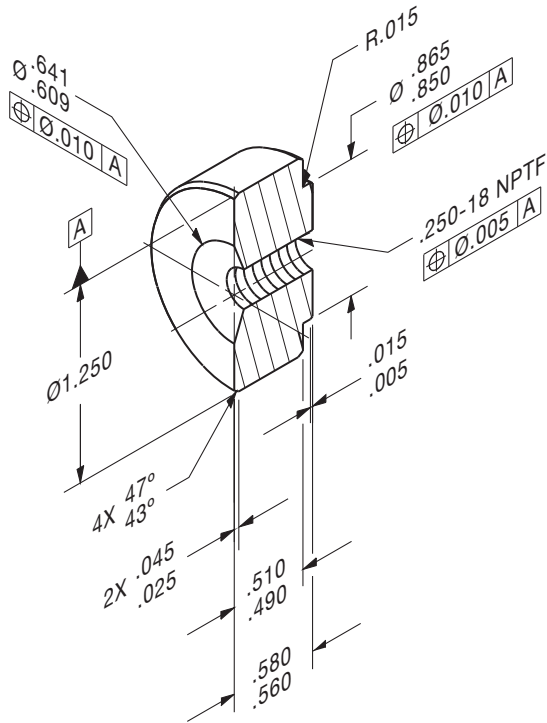
**PROBLEM 13.3 (in.)**

Part Name: Half Coupling

Material:  $\varnothing$  1.250 6061-T6 aluminum

SPECIFIC INSTRUCTIONS: Provide MMC material condition after position tolerance except for RFS at threads.

Problem based on original art courtesy TEMCO.



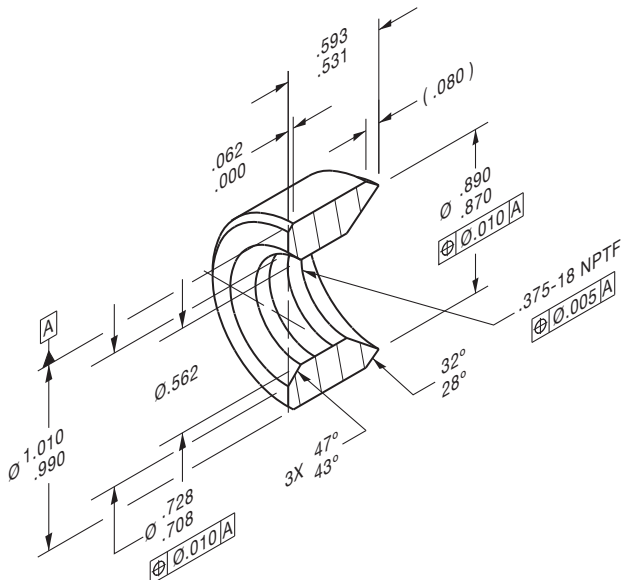
**PROBLEM 13.4 (in.)**

Part Name: Coupling

Material: AISI 1010, Killed

SPECIFIC INSTRUCTIONS: Provide MMC material condition after position tolerance except for RFS at threads.

Problem based on original art courtesy TEMCO.

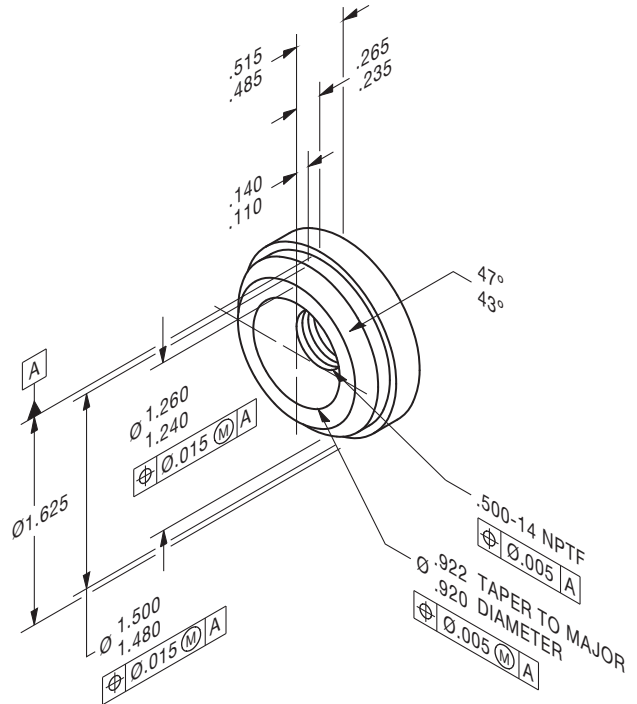


**PROBLEM 13.5 (in.)**

Part Name: Half Coupling

Material:  $\varnothing$  1.625 6061-T6511

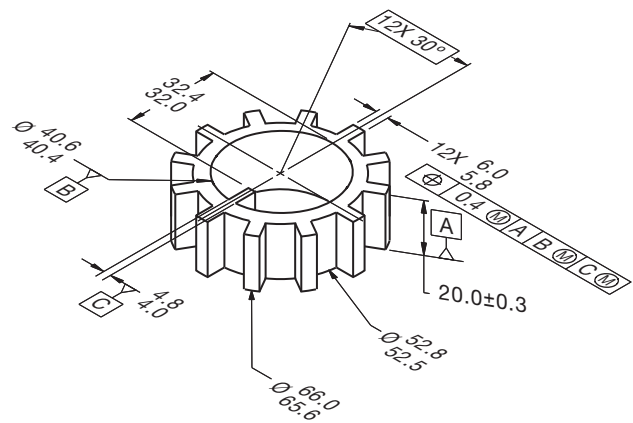
Problem based on original art courtesy TEMCO.



**PROBLEM 13.6 (metric)**

Part Name: Spline Plate

Material: SAE 3135

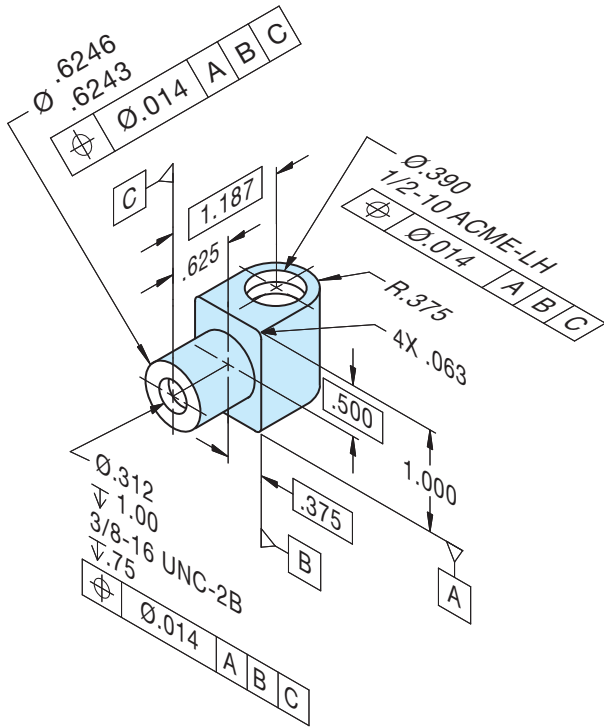


© Cengage Learning 2012

**PROBLEM 13.7 (in.)**

Part Name: Nut

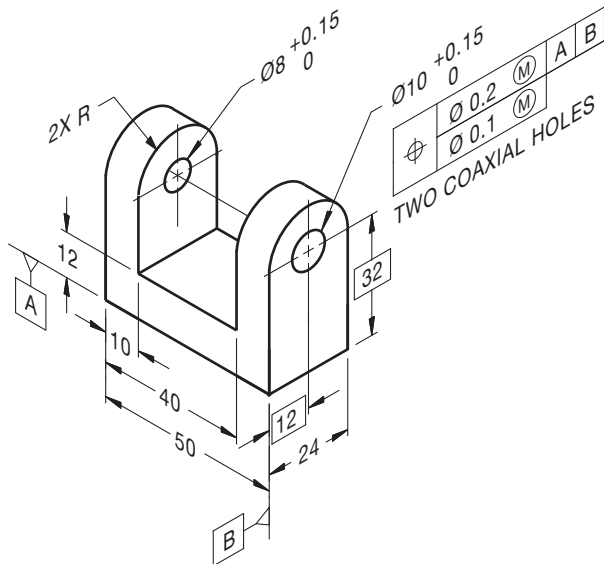
Material: No. 10 Bronze



**PROBLEM 13.8 (metric)**

Part Name: Coupling Bracket

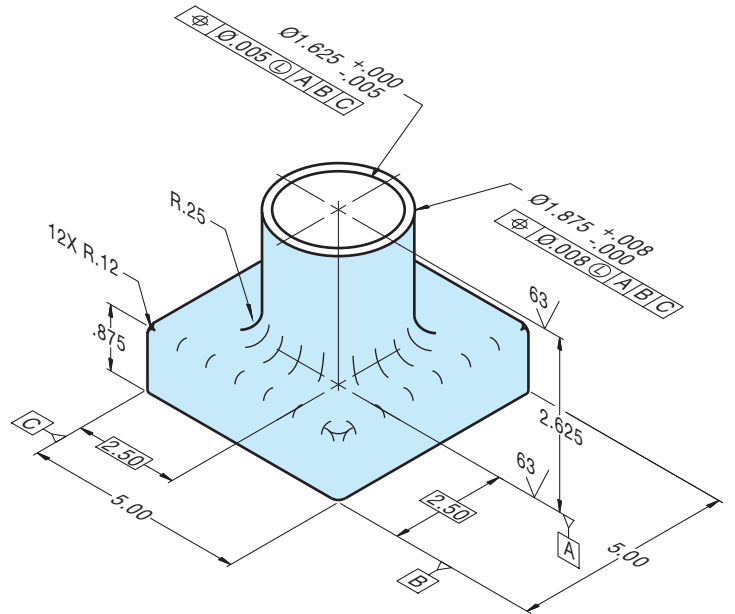
Material: SAE 4310 Steel



**PROBLEM 13.9 (in.)**

Part Name: Thrust Washer

Material: SAE 5150

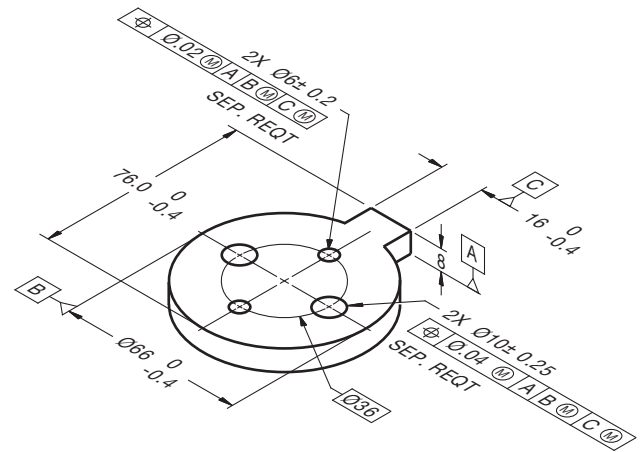


© Cengage Learning 2012

**PROBLEM 13.10 (metric)**

Part Name: Spacer

Material: SAE 4310

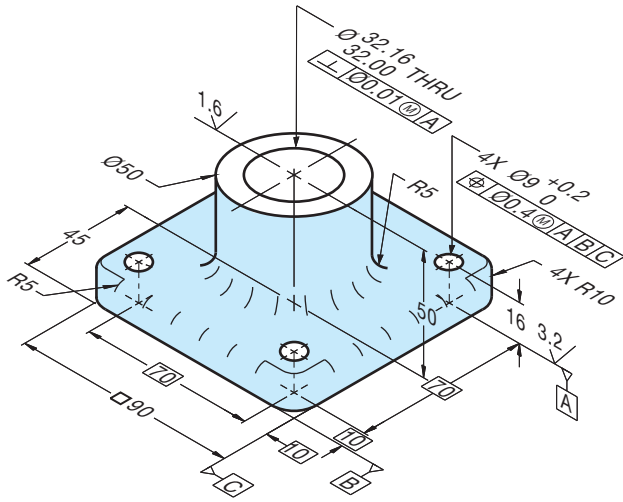


© Cengage Learning 2012

**PROBLEM 13.11 (metric)**

Part Name: Bearing Support

Material: SAE 1040

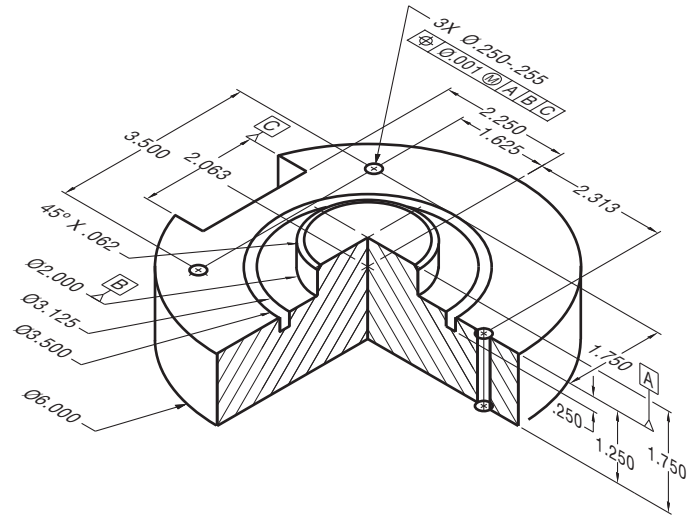


© Cengage Learning 2012

**PROBLEM 13.13 (in.)**

Part Name: Cover Plate

Material: Phosphor bronze

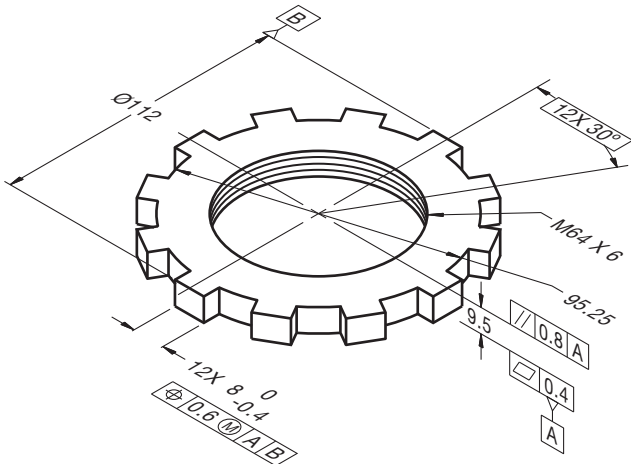


© Cengage Learning 2012

**PROBLEM 13.12 (metric)**

Part Name: Lock Nut

Material: SAE 3130

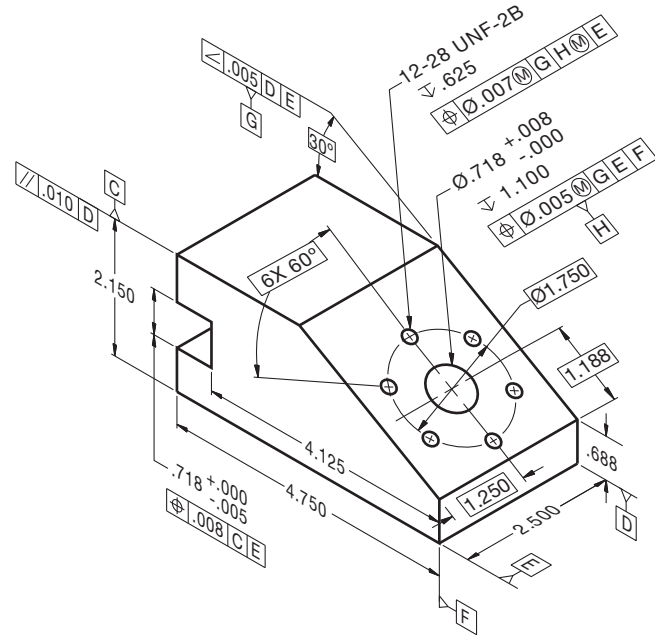


© Cengage Learning 2012

**PROBLEM 13.14 (in.)**

Part Name: Angle Support Mounting

Material: SAE 3110

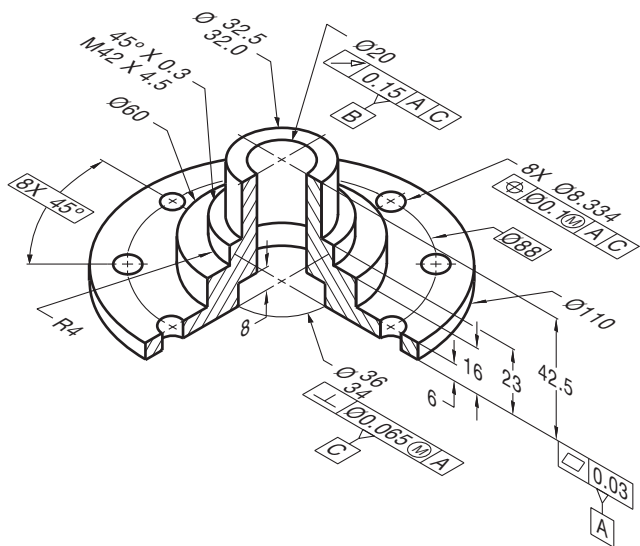


© Cengage Learning 2012

## PROBLEM 13.15 (metric)

Part Name: Hub

Material: SAE 3310



© Cengage Learning 2012

## Part 2: Problems 13.16 Through 13.23



To access the Chapter 13 problems, go to the Student CD, select **Chapter Tests and Problems** and **Chapter 13**, and then open the problem of your choice or as assigned by your instructor. Solve the problems using the instructions provided on the CD, unless otherwise specified by your instructor.

## Design Problem

## Part 3: Problem 13.24



To access the Chapter 13 problems, go to the Student CD, select **Chapter Tests and Problems** and **Chapter 13**, and then open the problem of your choice or as assigned by your instructor. Solve the problems using the instructions provided on the CD, unless otherwise specified by your instructor.

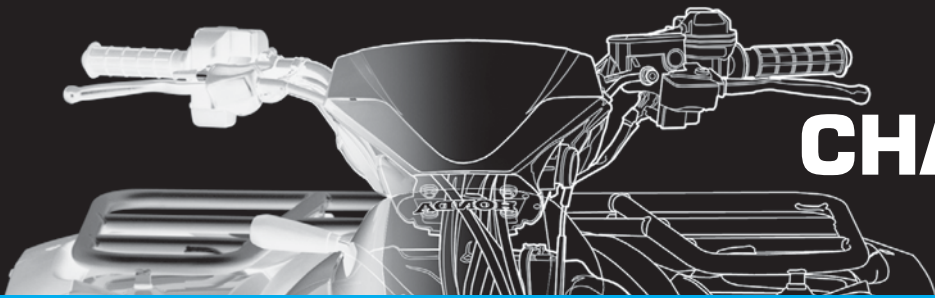
## Math Problems

## Part 4: Problems 13.25 Through 13.34



To access the Chapter 13 problems, go to the Student CD, select **Chapter Tests and Problems** and **Chapter 13**, and then open the math problem of your choice or as assigned by your instructor. Solve the problems using the instructions provided on the CD, unless otherwise specified by your instructor.





# CHAPTER 14

## Pictorial Drawings and Technical Illustrations

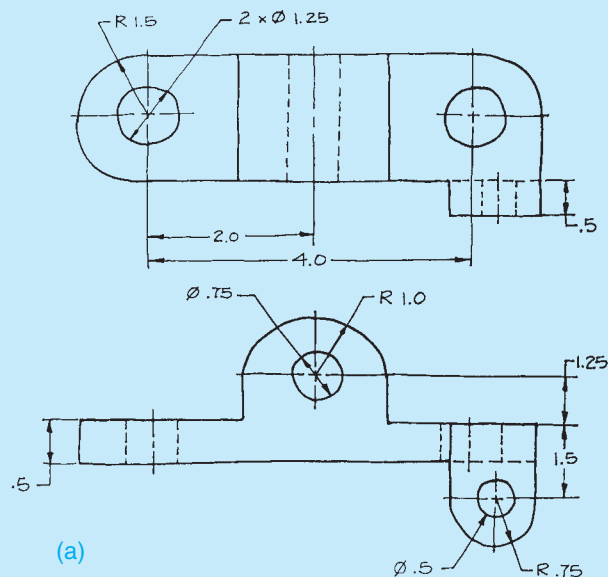
### LEARNING OBJECTIVES

After completing this chapter, you will:

- Draw three-dimensional objects using 3-D coordinates.
- Construct objects using isometric, diametric, or trimetric methods.
- Construct objects using oblique drawing methods.
- Draw objects using one-, two-, or three-point perspective.
- Apply a variety of shading techniques to pictorial drawings.
- Given an orthographic engineering sketch of a part or assembly, draw the part in pictorial form using proper line contrasts and shading techniques.

### THE ENGINEERING DESIGN APPLICATION

The design and manufacturing department has proposed a new part using two-dimensional (2-D) orthographic sketches. The sketches are extremely crude, and it is your task to construct an isometric drawing that can be used for visualization purposes and to construct a prototype. Your first task is to create a three-dimensional (3-D) pictorial drawing from the sketch provided. Check with the designers to verify dimensions and sizes. The engineering sketch shown in Figure 14.1a is used to draw an isometric view of the object.

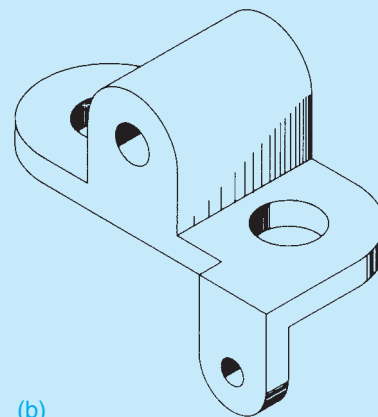


**FIGURE 14.1** Using an engineering sketch to create an isometric drawing. Dimension values in this figure are in inches.

After you confirm the accuracy of the 2-D sketch, begin construction of an isometric view. Use the following steps to construct the part:

1. Choose the view of the object that best shows most of the features of the part. Orient this view facing to the left or right.
2. Use the centerline layout method to locate the axis lines of the circular features.
3. Lay out additional thicknesses and features using the coordinate, or box-in, method.
4. Use proper ellipses to draw circles and arcs.
5. Use different widths for line contrast.
6. Apply shading as required.

The completed object is shown in Figure 14.1b.



© Cengage Learning 2012

## STANDARDS

**ASME** The ASME standard for pictorial drawings is ASME Y14.4M, *Pictorial Drawing*. This standard establishes pictorial drawing-related definitions and illustrates the different kinds of 3-D representation practices commonly used on engineering drawings.

## INTRODUCTION TO PICTORIAL DRAWING AND TECHNICAL ILLUSTRATION

### PICTORIAL DRAWINGS

The term **pictorial** is related to pictures, and pictures are representations by painting, drawing, or photograph. The intent of **pictorial drawings** is for the image to look realistic. Pictorial drawing is an ancient form of graphic communication; using the 3-D CADD applications discussed in Chapter 3, it is one of the most modern forms of graphic communication and is increasingly common. Pictorial drawings are often used to accompany 2-D orthographic multiview drawings to provide a realistic 3-D view to help improve visualization. Figure 14.2 shows an example of a 2-D orthographic drawing with a 3-D pictorial view in the upper-right corner for visualization purposes. Pictorial drawings are useful in mechanical design, manufacturing production, architecture, construction, assembly instructions, service and repair manuals, and sales brochures. Pictorial drawings are used to clarify basic and complicated engineering designs when it can be difficult to interpret 2-D multiview drawings. Pictorial drawings also help designers and engineers work out spatial problems such as clearances and interferences. Pictorial drawing is used, as shown in Chapter 15, *Working Drawings*, to present an exploded assembly drawing with a correlated parts list. There are a variety of pictorial drawing styles, which are used for different purposes and explained throughout this chapter. Some of the pictorial drawing styles are commonly used while others are used occasionally. Two-dimensional drawings can easily be generated from a 3-D model. As designers and engineers continue to move to 3-D modeling software, most 2-D production drawings will be created from the 3-D model.

Many of the techniques provided in this chapter are applied commonly with manual drafting skills, although they can be used with 3-D CADD and other illustration programs. A review of Chapter 3, *Computer-Aided Design and Drafting (CADD)* can give you additional insight into the power of 3-D modeling and its applications.

### Solid Models in Pictorial Drawing

**Solid models** are realistic 3-D pictorial models and allow you to analyze exterior and interior object characteristics. Designers and engineers use solid models to perform interference and collision checks, mass calculations, simulations, and generate machining code for part manufacturing. **Parametric solid modeling** CADD programs involve the idea of developing solid models that contain **parameters**, which are controls, limits, and

checks that allow you to easily and effectively make changes and updates. This means that when you describe the size, shape, and location of model geometry using specific parameters, you can easily modify those specifications to explore alternative design options. The parametric concept builds **intelligence** into the model, because parametric modeling occurs as a result of the software programs' ability to store and manage model information. This information includes knowledge of all model characteristics, such as calculations, sketches, features, dimensions, geometric parameters, when each piece of the model was created, and all other model history and properties. Figure 14.3 shows a 3-D solid model of a calculator.

### Three-Dimensional Visualization Tools

**Three-dimensional visualization** tools exist that bridge the gap between 3-D engineering data and the illustration program. These software programs directly import the engineering model files and let the illustrator layout and explode the model as needed. When the explode has been completed, it can be exported and brought into the illustration program for finishing. This usually includes adding centerlines, adjusting line weights, and adding callouts.

Either through conversion or direct import, these 3-D models can be rotated, exploded, and positioned for each need and saved to a "snapshot" for later use.

Generally, these programs can also produce thick and thin lines as well as colorful renderings and exported to such formats as .SVG, .PNG, .JPG, and .CGM. Figure 14.4 shows a 3-D model exported and brought into the illustration program for finishing.

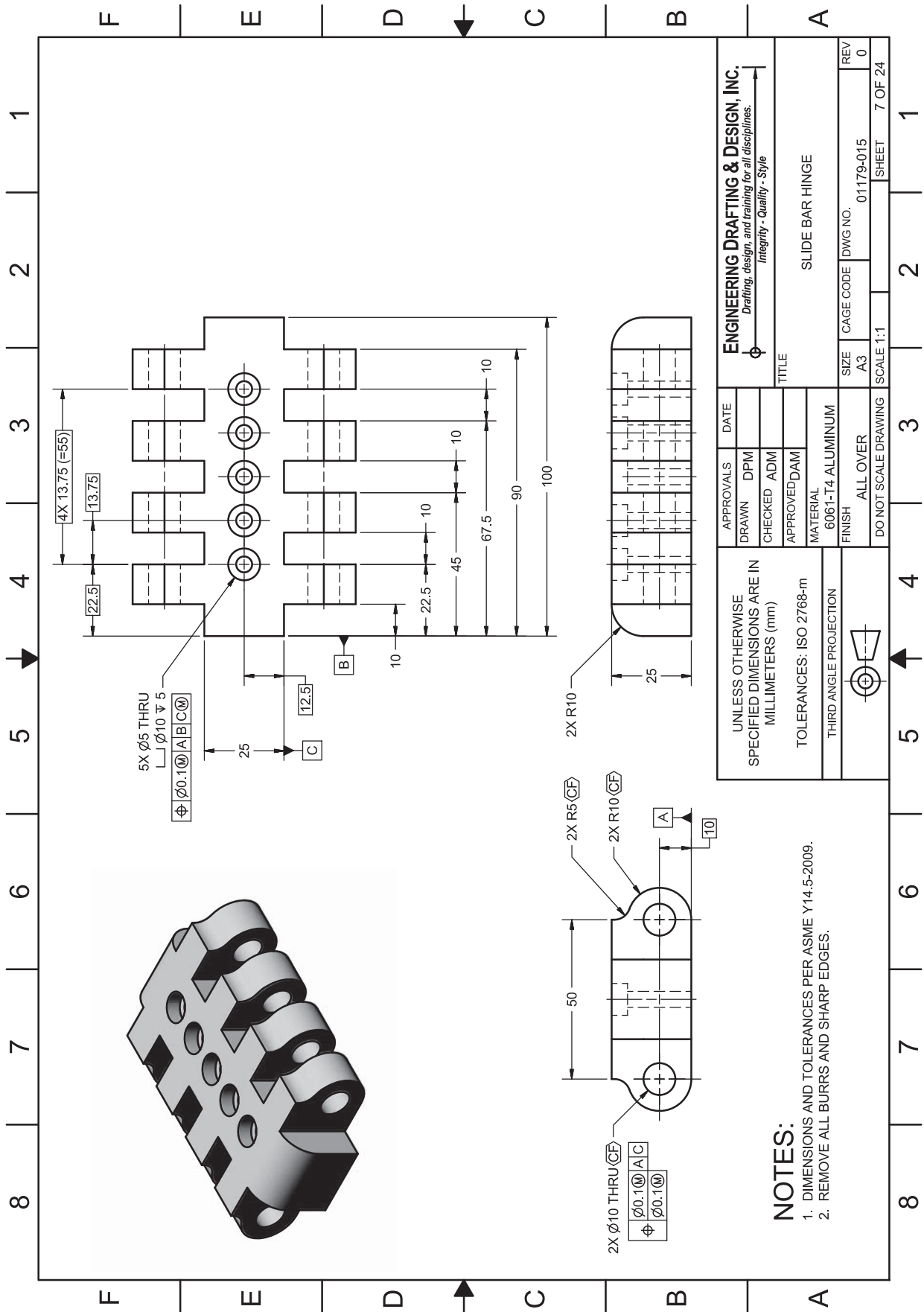
### PICTORIAL DRAWINGS

Most products are made from multiview drawings that allow you to view an object with the line of sight perpendicular to the surface you are looking at. The one major shortcoming of this form of drawing is the lack of depth. A single view of the object providing a more realistic representation is often helpful for visual relation. This realistic single view is achieved with pictorial drawing.

The most common forms of pictorial drawing used in engineering drawing are **isometric** and **oblique**. These two basic forms of pictorial drawing are easy to create if you can visualize objects in orthographic projection and three dimensions.

Isometric drawing belongs to a family of pictorial representation known as **axonometric projection**. Two other similar forms of drawing are in this group. **Dimetric projection** involves the use of two different scales. The simplest is isometric, which uses a single scale for all axes. **Trimetric projection** is the most involved of the three and uses three different scales for measurement. Figure 14.5 illustrates the differences in scale between isometric, diametric, and trimetric drawings.

The terms drawing and projection should be clarified. A **projection** is an exact representation of an object projected onto a plane from a specific position. Your line of sight to the various



**FIGURE 14.2** A 2-D multiview drawing of a part with a pictorial drawing in the upper-right corner to aid in visualization. Dimension values in this figure are in inches.



FIGURE 14.3 A 3-D solid model of a calculator. Courtesy O'Neil & Associates, Inc.

points on the object passes through a projection plane. The representation on a drawing sheet of the points of the object on the projection plane becomes the **drawing**. Exact projections of objects are time consuming to make and often involve the

use of odd angles and scales. Therefore, most drafters and illustrators work with axonometric drawing techniques rather than true projection techniques. Creating an axonometric drawing involves the use of approximate scales and angles that are close enough to the projection scales and angles to be acceptable.

The most realistic type of pictorial illustration is **perspective drawing**. The use of vanishing points in the projection of these drawings gives them the depth and distortion that the human eye perceives. Each of these types of pictorial drawings are examined in this chapter with step-by-step construction methods. In addition, you will see how pictorial drawings can be drawn with a computer-aided drafting system.

### Technical Illustration

Pictorial drawing is a term that is often used interchangeably with **technical illustration**. But pictorial drawing includes only line drawings done in one of several 3-D methods, whereas technical illustration involves the use of a variety of artistic and graphic arts skills and a wide range of media in addition to pictorial drawing techniques. Figure 14.6 is an example of a pictorial drawing. Figure 14.7 shows a technical illustration, and Figure 14.8 shows a 3-D rendering. Pictorial drawings are most often the basis for technical illustrations.

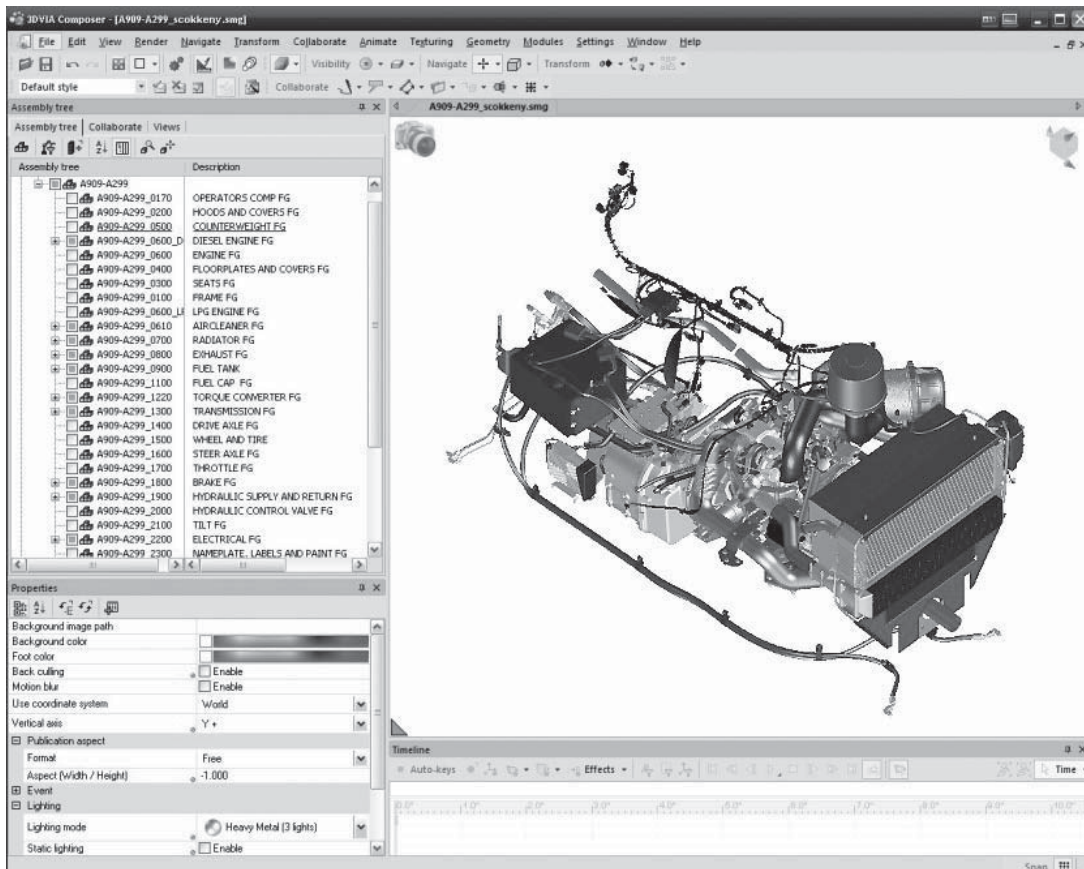
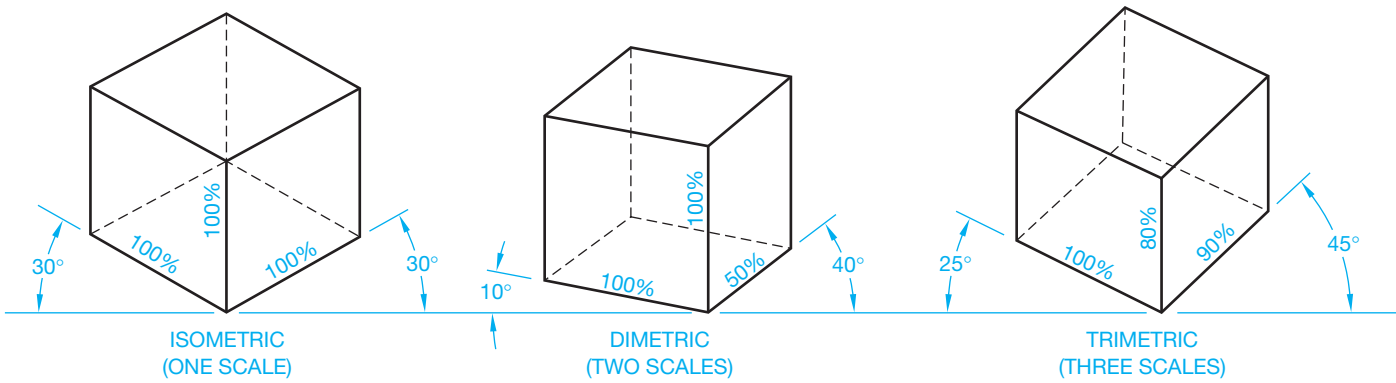


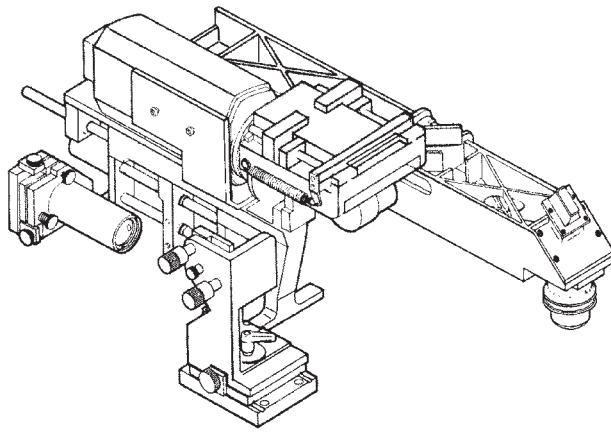
FIGURE 14.4 A 3-D model exported and brought into the illustration program for finishing.

Courtesy O'Neil & Associates, Inc.



© Cengage Learning 2012

FIGURE 14.5 Three types of axonometric projections.



Courtesy Industrial Illustrators, Inc.

FIGURE 14.6 Pictorial drawing.



Courtesy O'Neil & Associates, Inc.

FIGURE 14.8 A 3-D rendering.



Courtesy O'Neil & Associates, Inc.

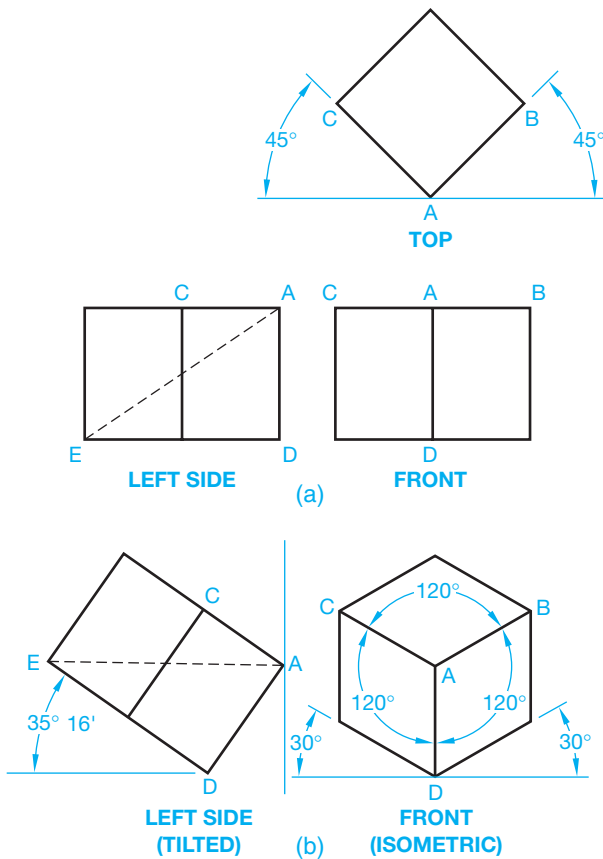
FIGURE 14.7 An example of a technical illustration.

## Uses of Pictorial Drawings

Pictorial drawings are excellent aids in the design process because they allow designers and engineers to view the objects at various stages of development. Pictorial drawings are used in instruction manuals, parts catalogs, advertising literature, technical reports, presentations, and as aids in the assembly and construction of products.

## ISOMETRIC PROJECTIONS AND DRAWINGS

The word isometric means equal (iso) measure (metric). The three principal planes and edges make equal angles with the plane of projection. Creating isometric sketches was covered in Chapter 5, *Sketching Applications*. An isometric projection is achieved by first revolving the object. For example, a 1 in. cube is rotated 45° in a multiview drawing as shown in Figure 14.9a. The object is then



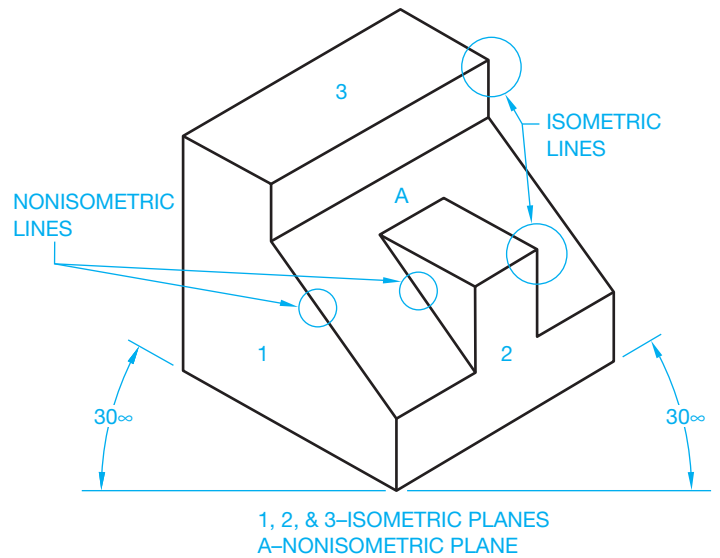
**FIGURE 14.9** Construction of an isometric projection. (a) Multiview setup. (b) Isometric projection construction.

tilted forward until the diagonal line AE is perpendicular to the projection plane as seen in the side view of Figure 14.9b. This creates an angle of 35°16' between the vertical axis AD and the plane of projection. See the LEFT SIDE (TILTED) in Figure 14.9b. When viewed in the isometric or front view, this axis appears vertical. The remaining two principal axes, AB and AC, are at 30° to a horizontal line as shown in the FRONT (ISOMETRIC) in Figure 14.9b.

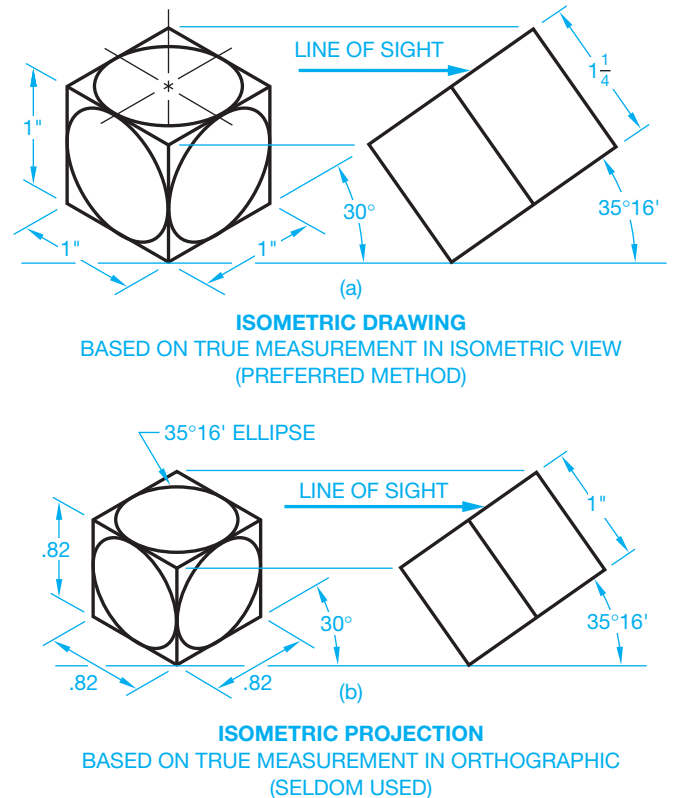
The three principal axes are called **isometric lines**, and any line on or parallel to the three principal axes is also an isometric line. These lines can all be measured. Any lines not on or parallel to the three isometric axes are **nonisometric lines** and cannot be measured. The angles between each of these three isometric axes are 120° as shown in the FRONT (ISOMETRIC) in Figure 14.9b. The three planes between the isometric axes and any plane parallel to them are called **isometric planes**. Figure 14.10 shows the isometric and nonisometric line in an isometric view.

### Isometric Scale

An isometric drawing is created using a regular scale. This is most common in industry because it does not involve the use of special scales. The only difference between an isometric drawing and an isometric projection is the size. The isometric drawing appears slightly larger than the isometric projection. Figure 14.11 illustrates the differences between the isometric drawing and the isometric projection.

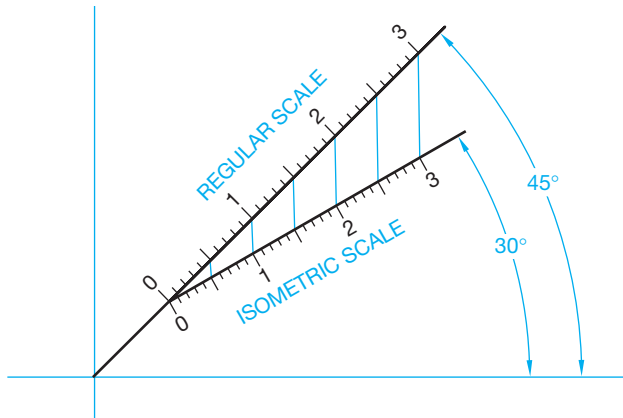


**FIGURE 14.10** Isometric and nonisometric planes. © Cengage Learning 2012



**FIGURE 14.11** The differences between isometric drawing and isometric projection. (a) The preferred isometric drawing is based on true measurement in isometric view. (b) The isometric projection based on true measurements in orthographic project is seldom used. © Cengage Learning 2012

The isometric projection is a true representation of an object rotated and tilted in the manner previously described. An isometric projection must be drawn using an isometric scale. An isometric scale is created by first laying a regular scale at 45°



© Cengage Learning 2012

FIGURE 14.12 Projection of regular scale to isometric scale.

and projecting the increments of that scale vertically down to a blank scale drawn at an angle of  $30^\circ$ . The resulting isometric scale is shown in Figure 14.12. A 1 in. measurement on the regular scale now measures .816 in. on the isometric scale.

## TYPES OF ISOMETRIC DRAWINGS

Isometric drawing is a form of pictorial drawing in which the receding axes are drawn at  $30^\circ$  from the horizontal as shown in Figure 14.9. There are three basic forms of isometric drawing, known as regular, reverse, and long-axis isometric.

### Regular Isometric


The top of an object can be seen in the **regular isometric** form of drawing. An example is shown in Figure 14.13a. This is the most common form of isometric drawing. You can choose to view the object from either side when using a regular isometric drawing.

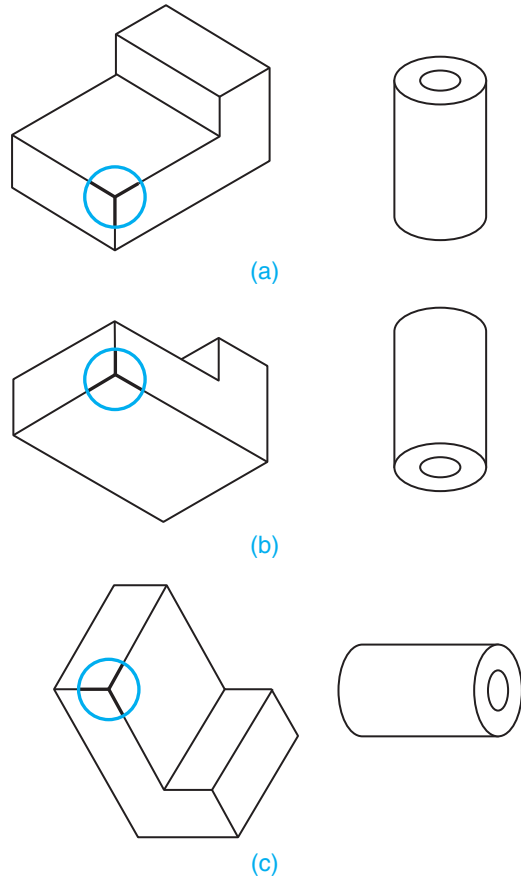
### Reverse Isometric

The only difference between **reverse** and regular isometric is that you can view the bottom of the object instead of the top. The  $30^\circ$  axis lines are drawn downward from the horizontal line instead of upward. Figure 14.13b shows an example of reverse isometric.

### Long-Axis Isometric

The **long-axis isometric** drawing is normally used for objects that are long, such as shafts. Figure 14.13c shows an example of the long-axis form.

 **NOTE:** You should choose the view that gives the most realistic presentation of the object. For example, if the object is normally seen from below, then the reverse isometric is the proper form to use.



© Cengage Learning 2012

FIGURE 14.13 Isometric axis variations: (a) Regular axis isometric drawing. (b) Reverse axis isometric drawing. (c) Long-axis isometric drawing.

## ISOMETRIC CONSTRUCTION TECHNIQUES

Just as objects differ in their geometric makeup, so do the construction methods used to draw the object. Different techniques exist to assist you in constructing the various shapes.

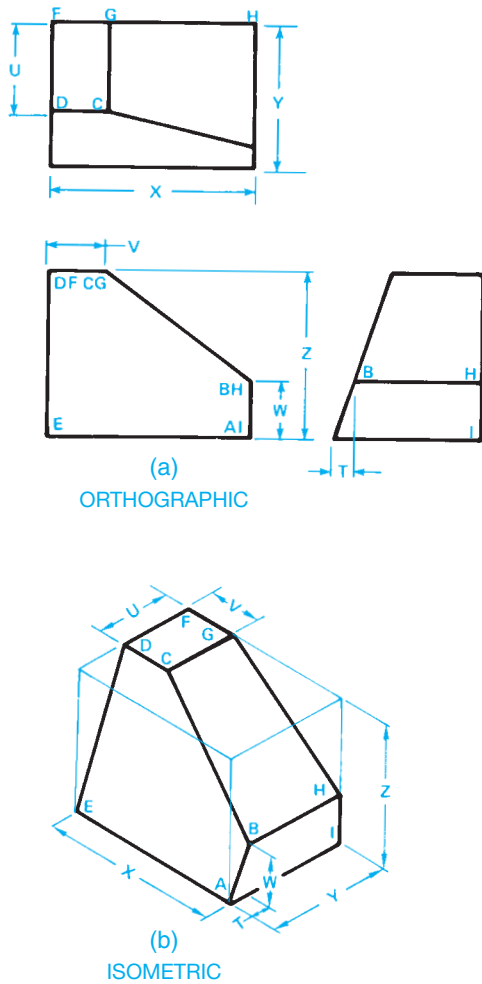


**NOTE:** Today, most technical illustrating is done in software packages developed specifically for this purpose, though the basic illustration techniques still apply. CADD technical illustration software applications are discussed later in this chapter.

### Using the Box or Coordinate Method for Drawing an Isometric Object

The most common form of isometric construction is the **box** or **coordinate method** and is used on objects that have angular or radial features. The orthographic views of the object to be drawn as examples are shown in Figure 14.14a, and explained as follows.

First, draw an isometric box the size of the overall dimensions of the object  $X$ ,  $Y$ , and  $Z$  (see Figure 14.14b). Then the measurements of the features of the object are transferred to the isometric box. Any line that is on or parallel to one of the isometric axes can



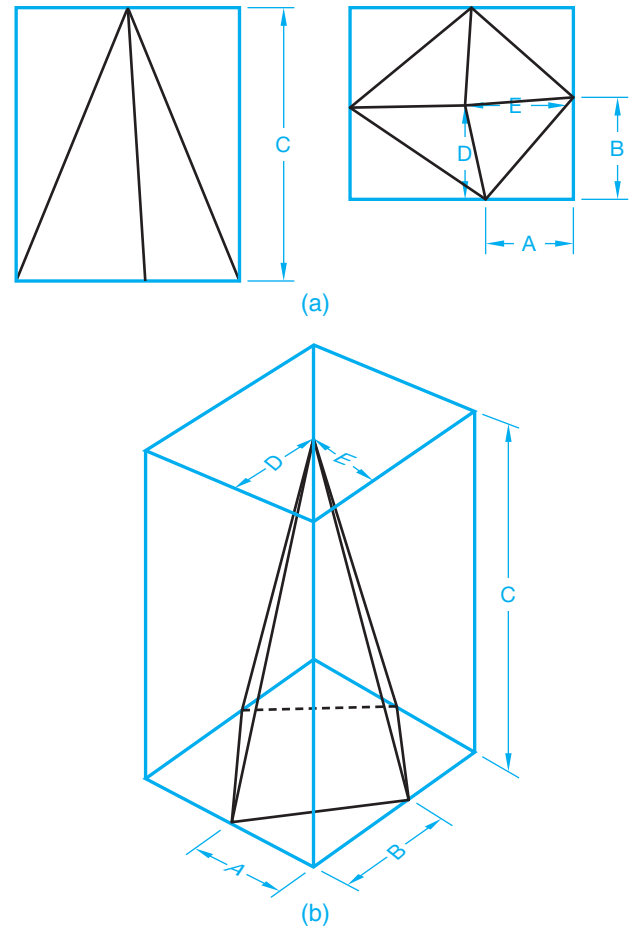
**FIGURE 14.14** Box method of isometric construction: (a) Orthographic view (multiview). (b) Isometric view.

be measured directly and transferred to the isometric drawing. To locate points D and C, measure dimension U from points F and G. Point E is located at the lower-left corner of the box. Draw a line from E to D. This is a nonisometric line. Next, locate point H by measuring up distance W from the bottom-right corner of the box. This is an isometric line, because it is drawn on or parallel to an isometric axis. Draw a construction line at a 30° angle toward the front vertical axis. Now draw a line from A parallel to line ED until it intersects the line from H. This intersection is point B. The location of point B can also be found by measuring the horizontal dimension T from point A and the vertical dimension W.

It can be necessary to draw construction lines on the multiviews and transfer measurements directly from these views to the isometric view. This method works well with irregularly shaped objects such as the one shown in Figure 14.15.

### Using the Centerline Layout Method for Drawing an Isometric Circles and Arcs

The centerline technique is used on objects with many circles and arcs. The use of this method is shown in Figures 14.16a through d. The orthographic (multiview) layout of the example



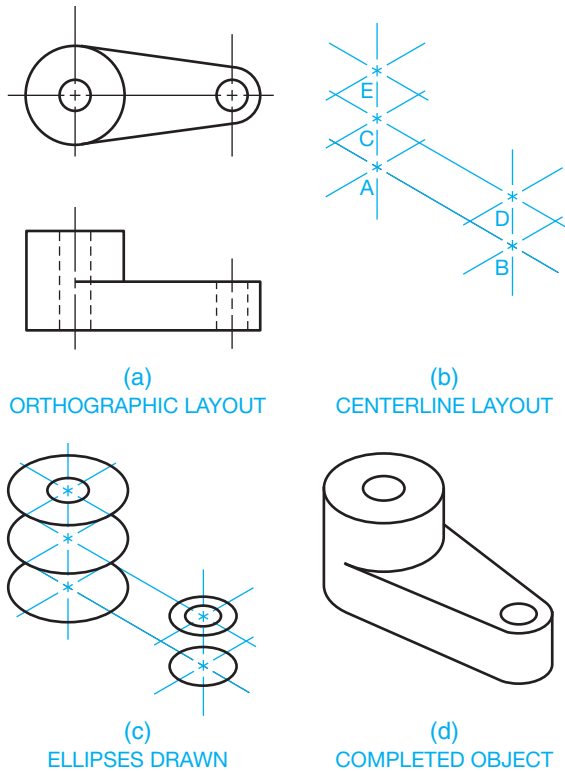
**FIGURE 14.15** Isometric box method for an irregular object. (a) Establishing dimension values in the multiviews. (b) Laying out the isometric view from the dimensions established in the multiviews. © Cengage Learning 2012

object is shown in Figure 14.16a. The centerline method begins with isometric lines representing the centerlines of the object as shown in Figure 14.16b. This locates the center points of all the circles and arcs. Next, find a good reference point from which you can work, such as the bottom of the object in Figure 14.16a. Center points A and B are first established, then vertical axis lines are drawn from these points. Now the vertical locations of center points C, D, and E can be measured as shown in Figure 14.16b. Circles in an isometric drawing are drawn as isometric ellipses. Next, determine the dimensions of the isometric ellipses for each circle and draw them at their proper locations as shown in Figure 14.16c. The finished drawing is shown in Figure 14.16d.

Circles in isometric are isometric ellipses as previously mentioned. The orientation of an isometric ellipse depends on the isometric plane where the ellipse is placed. Figure 14.17 shows an isometric box. Notice the orientation of the isometric ellipse in the right plane, left plane, and horizontal plane. You can always draw an isometric ellipse in the correct orientation if you first determine the isometric plane where the ellipse is placed.

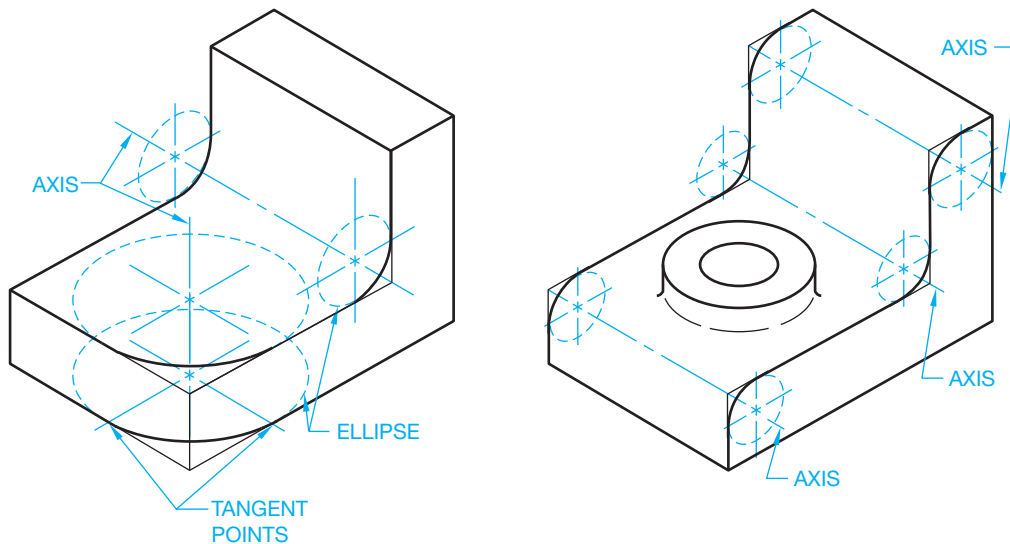
Arc locations are found in the same way as circles, and the orientation of the isometric ellipse is also the same, except an



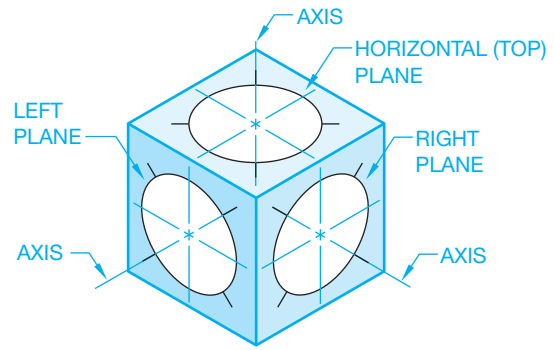


**FIGURE 14.16** Isometric centerline layout method for drawing isometric circles: (a) Orthographic layout (multiview). (b) Centerline layout. (c) Draw the isometric ellipses. (d) Completed object without centerlines. Centerlines can be added if desired.

isometric arc is only a portion of an isometric circle. To draw an isometric arc, first find the center point of the arc and then locate the tangent points where the arc meets the lines. Draw only the portion of the isometric ellipse needed to complete the isometric arc as shown in Figure 14.18.



**FIGURE 14.18** Isometric arc layout and drawing isometric fillets and rounds.

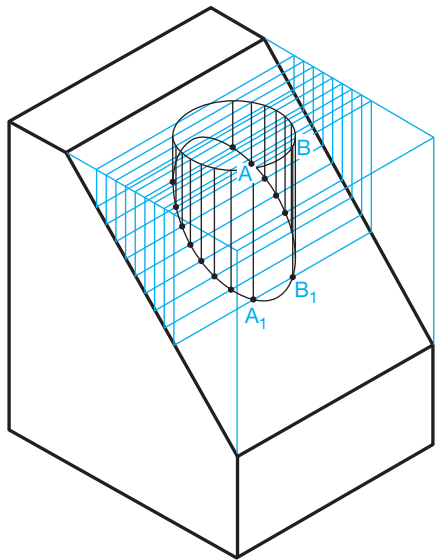


**FIGURE 14.17** The orientation of an isometric circle is related to the isometric plane where it is placed.

Constructing isometric circles is easy with CADD software such as AutoCAD by using the ELLIPSE command, and drawing isometric arcs is similarly easy with the isocircle option of the ELLIPSE command. The isometric crosshairs can be toggled while the ellipse is attached to the crosshairs, so you can see the ellipse in the left-, top-, and right-side orientations. This same construction technique can be used in illustration programs such as the Parametric Technology Corporation (PTC) IsoDraw, making the creation of objects like ellipses very easy.

### Establishing Intersections

In one common type of **intersection**, a cylindrical hole passes through an oblique plane. To establish an isometric feature in an oblique plane, draw an isometric ellipse at the top of the boxed surface of the object as shown in Figure 14.19. Next, draw a series of construction lines parallel to one side of the box that pass through the ellipse. Project each of these lines down



© Cengage Learning 2012

FIGURE 14.19 Construction of ellipse on isometric oblique plane.

the sides of the box and across the oblique surface. Each line forms a trapezoid or parallelogram, depending on the shape of the object. The points at which each line intersects the ellipse, such as A and B, are projected straight down to the opposite side of the parallelogram. These new points, A1 and B1, are now points on the perimeter of the hole in the oblique surface. Continue this method by finding several points around the isometric ellipse and projecting downward to locate the isometric shape in the oblique plane.

Another common form of intersection occurs when two cylinders meet. This construction is similar to the one previously described. Figure 14.19 shows a multiview drawing of two intersecting cylinders and construction of the intersecting cylinders in an isometric view. Look at Figure 14.20 while you use the following instructions. Find the center point location of the smaller intersecting cylinder and draw the isometric ellipse on the center. Next, draw as many construction lines passing through the ellipse as needed to produce a smooth curve on the intersection. Project these lines to the end of the main cylinder, down to the edge, and then back along the cylinder. Now project points on the ellipse down to the corresponding construction line on the cylinder, such as A to A1 and B to B1. Then connect the points using a tool such as polyline in AutoCAD to produce the line of intersection between the two cylinders.

### Drawing Isometric Sections

Full and half sections are commonly used in technical illustration. Full and half sections are typically drawn along the isometric axes. The section lines in full sections should all be drawn in the same direction; those on a half section should appear in opposite directions. See the section lines illustrated in Figure 14.21a and b. The section lines in offset sections

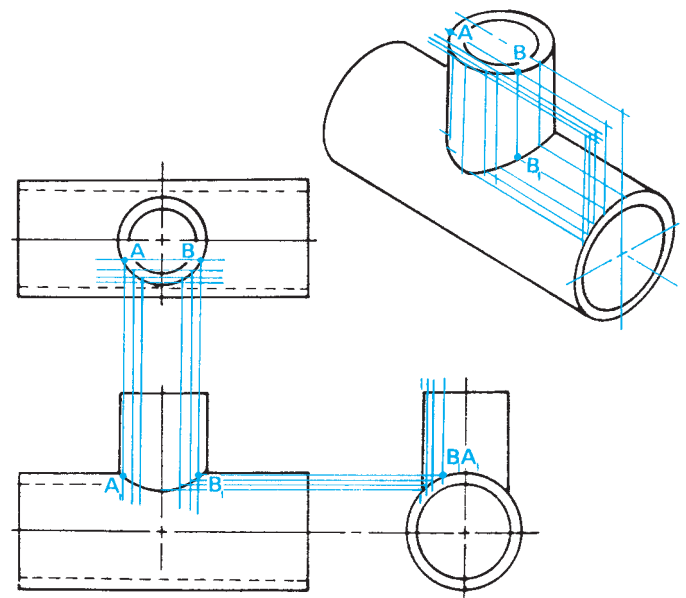


FIGURE 14.20 Isometric construction of two intersecting cylinders.  
© Cengage Learning 2012

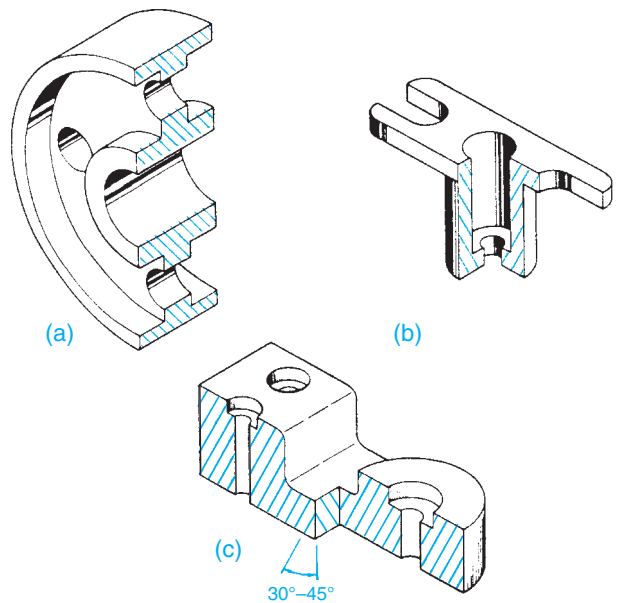
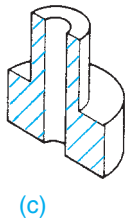
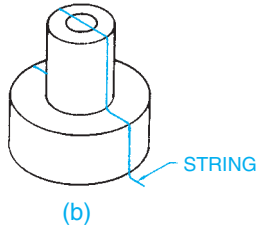
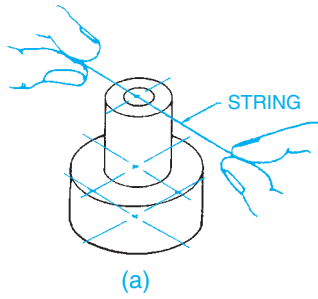


FIGURE 14.21 Isometric sections: (a) Full section. (b) Half section. (c) Offset section.

should change directions with each jog in the part as shown in Figure 14.21c.

The method you use to draw an isometric section depends on the isometric plane where you want the section to appear. A technique you can use to help visualize the cutting-plane line is to imagine a long string stretched out along the isometric axis that you plan to cut. If you let the string continue around the profile of the object, it comes to rest along the axis where the cut is to be made as shown in Figure 14.22.

© Cengage Learning 2012

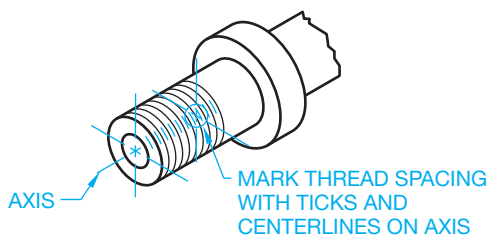


**FIGURE 14.22** Visualize a string dropped along the cutting plane to create an isometric full section. (a) Holding a string over the object to help visualize the cutting plane location. (b) The string dropped down over the object represents the imaginary cutting plane. (c) The completed full section.

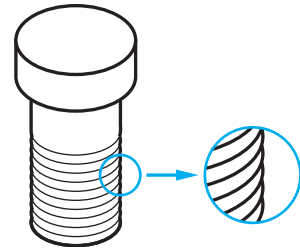
### Drawing Isometric Threads

Chapter 11, *Fasteners and Springs*, covered the drafting of 2-D screw threads. A review of this chapter is recommended as needed. Although there are three different types of 2-D thread representations discussed in Chapter 11, the detailed thread representation is commonly used when creating an isometric drawing.

Screw threads can be drawn in isometric by first measuring equal spaces along the shaft or hole to be threaded. Then, using the same size ellipse as the diameter of the shaft or hole, draw a series of parallel ellipses as shown in Figure 14.23.



**FIGURE 14.23** Isometric thread representation.



**FIGURE 14.24** Detailed isometric thread representation.

These ellipses represent the crests of the threads. This method achieves a simple isometric representation of threads.

A more detailed thread appearance can be achieved by giving each ellipse rounded ends instead of butting the ellipse into the straight sides of the shaft (see Figure 14.24). When using this technique, begin drawing the threads from the head of the shaft.

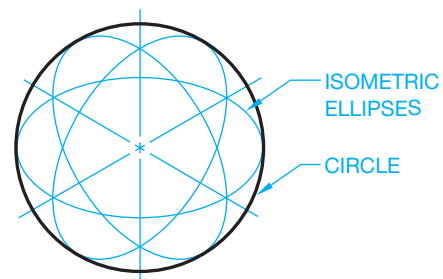
Drawing threads like those in Figure 14.24 can be done quickly by using software such as AutoCAD. To do this, draw the uppermost thread using an arc or ellipse and edit as needed by trimming or breaking the ellipse so it fits properly. Then use a command such as ARRAY and create a rectangular array of the required number of threads.

Programs such as IsoDraw can create threaded fasteners automatically which scale according to the size needed.

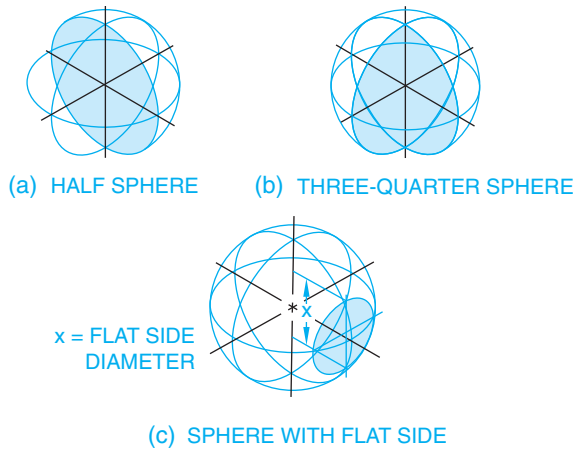
### Drawing Isometric Spheres

An isometric sphere is a circle. Figure 14.25 shows the construction of a sphere using three isometric ellipses drawn to represent the perpendicular axes of the circle. When drawing an isometric sphere, use a circle diameter that is 1-1/4 times larger than the actual sphere, because isometric drawings are 1-1/4 times larger than the actual representation.

Figure 14.26 shows how to draw isometric spheres that have been cut for sectioning or to create a flat surface on one plane. This figure shows a half sphere, three-quarter sphere, and a sphere with a flat side.



**FIGURE 14.25** Isometric sphere construction.



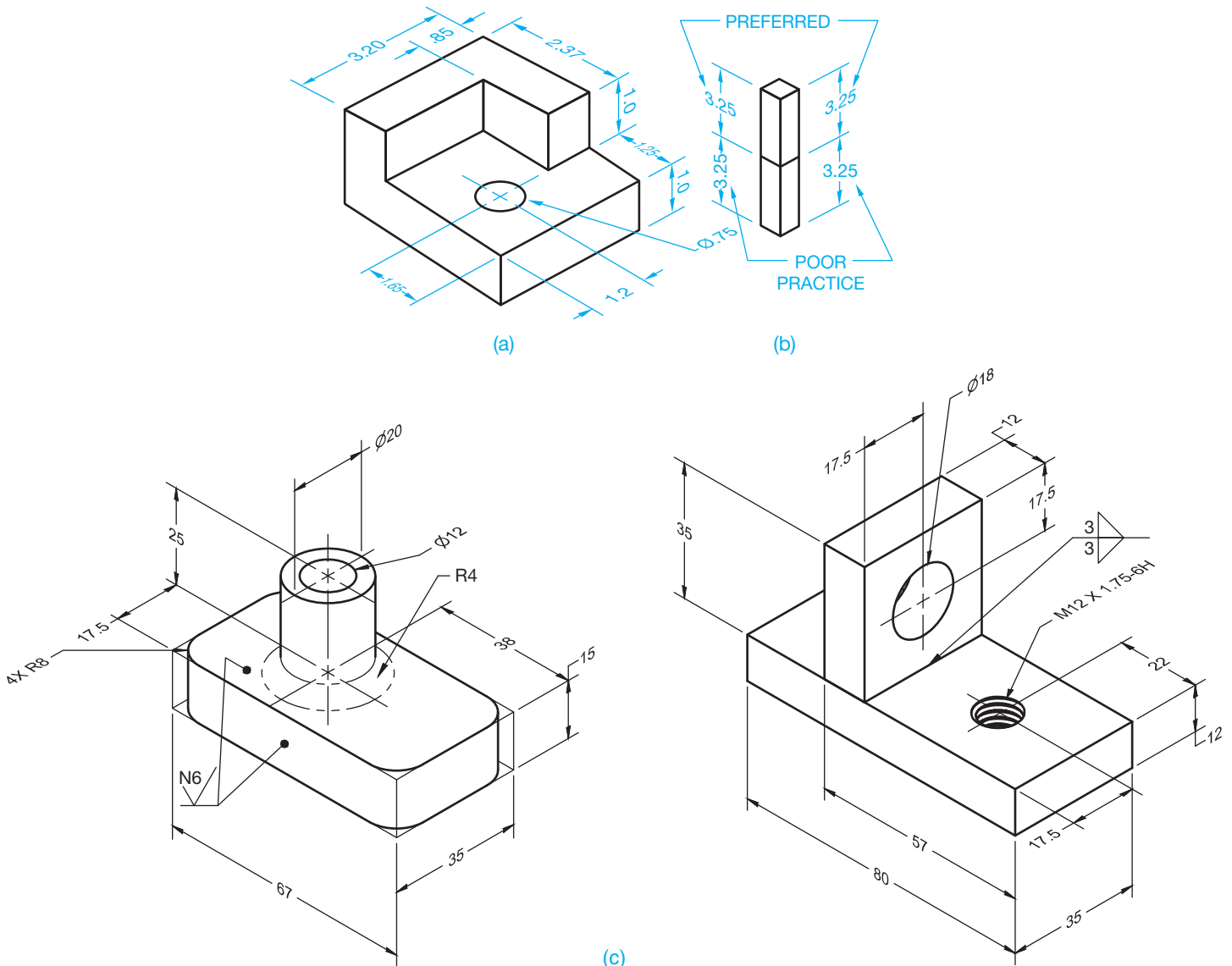
© Cengage Learning 2012

### Isometric Dimensioning

It is not common for isometric drawings of manufactured products to be dimensioned. However, some isometric piping drawings use dimensions for pipe runs and fitting locations. Industrial pipe drawings are covered in Chapter 21.

When doing isometric dimensioning, extension lines and dimension lines are drawn in the same isometric plane as the object being dimensioned as shown in Figure 14.27. This gives the appearance of each dimension lying in the plane of the extension lines. The dimension text is also drawn in the isometric plane for a natural appearance. Notice the orientation of the dimension text in Figure 14.27a and b. The alignment used in Figure 14.27a is correct practice. Figure 14.27b shows preferred practice and poor practice.

**FIGURE 14.26** Portions of isometric spheres. (a) Half sphere. (b) Three-quarter sphere. (c) Sphere with flat side.



**FIGURE 14.27** Isometric dimensioning. (a) Dimensions parallel to extension lines. (b) Various styles of dimensioning. (c) Isometric dimensioning applications based on ASME Y14.4M. Dimension values in this figure are in millimeters. © Cengage Learning 2012

STANDARDS

ASME Y14.4M, *Pictorial Drawing*, is the standard that establishes definitions for and illustrates the use of 3-D views for mechanical drawings. The standard recommends that dimensions and notes be unidirectional, reading from the bottom of the drawing and located outside the view whenever possible. Symbols for surface texture, welds, and other requirements use the standards described in the related chapters. Figure 14.27c shows isometric dimensioning applications based on ASME Y14.4M.

DIMETRIC PICTORIAL REPRESENTATION

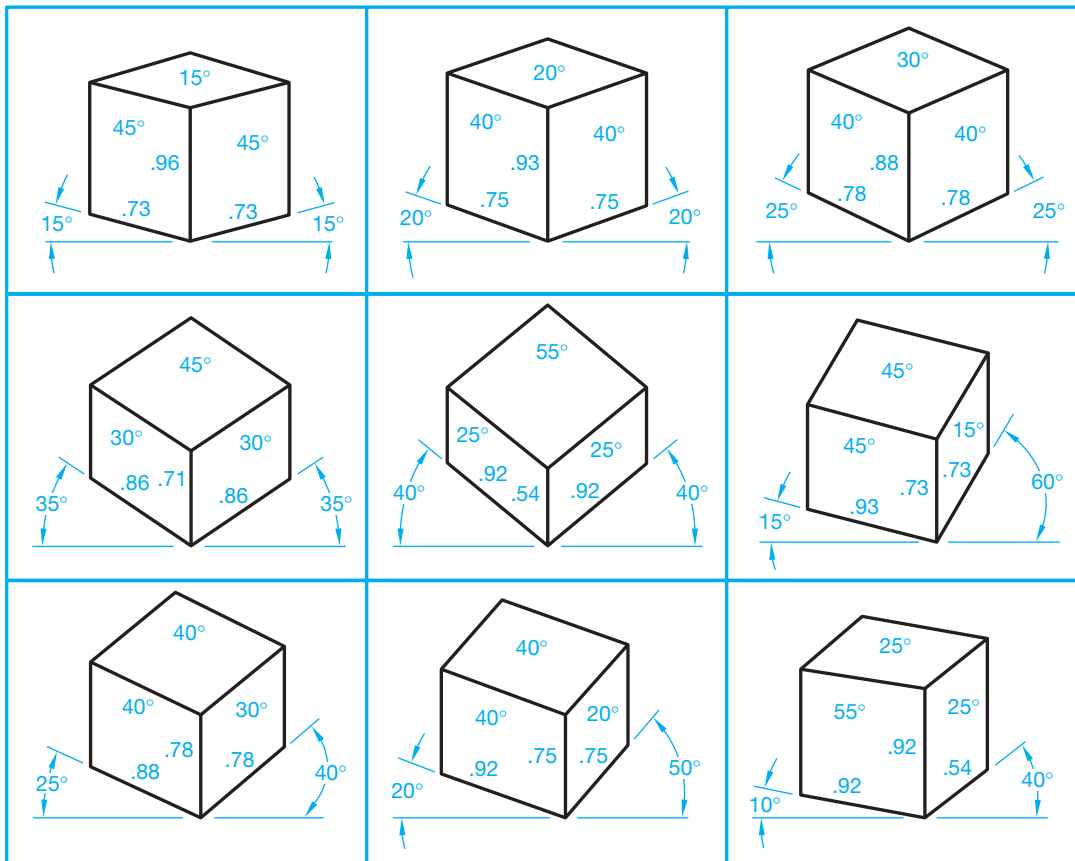
Dimetric projection is similar to isometric projection, but instead of all three axes forming equal angles with the plane of projection, only two axes form equal angles. The equal axes can be greater than 90° and less than 180° but cannot have an angle of 120°, because 120° is the isometric angle. The third axis can have an angle less or greater than the two equal axes, depending on the angles chosen. The two equal angles are foreshortened because they are not measured at full scale, and they are foreshortened equally. Because the third axis is projected at a different angle, it is foreshortened at a different scale. Full-size and foreshortened approximate scales are used on the diametric axes. Some common approximate diametric angles, scales, and ellipse angles are shown in Figures 14.28.

When drawing the dimension arrowhead, a technique is to draw the heel of the arrowhead parallel with the extension line. This further emphasizes the isometric plane where the dimension is placed (see Figure 14.27a).

TRIMETRIC PICTORIAL REPRESENTATION

The term trimetric refers to three measurements. Trimetric is a type of pictorial drawing in which none of the three principal axes makes an equal angle with the plane of projection. Because all three angles are unequal, the scales used to measure on the three axes are also unequal. Trimetric projection provides an infinite number of possible projections.

**NOTE:** Many of the problems at the end of chapters throughout this book are dimensioned isometric drawings.



© Cengage Learning 2012

FIGURE 14.28 Common approximate diametric angles, scales, and ellipse angles.

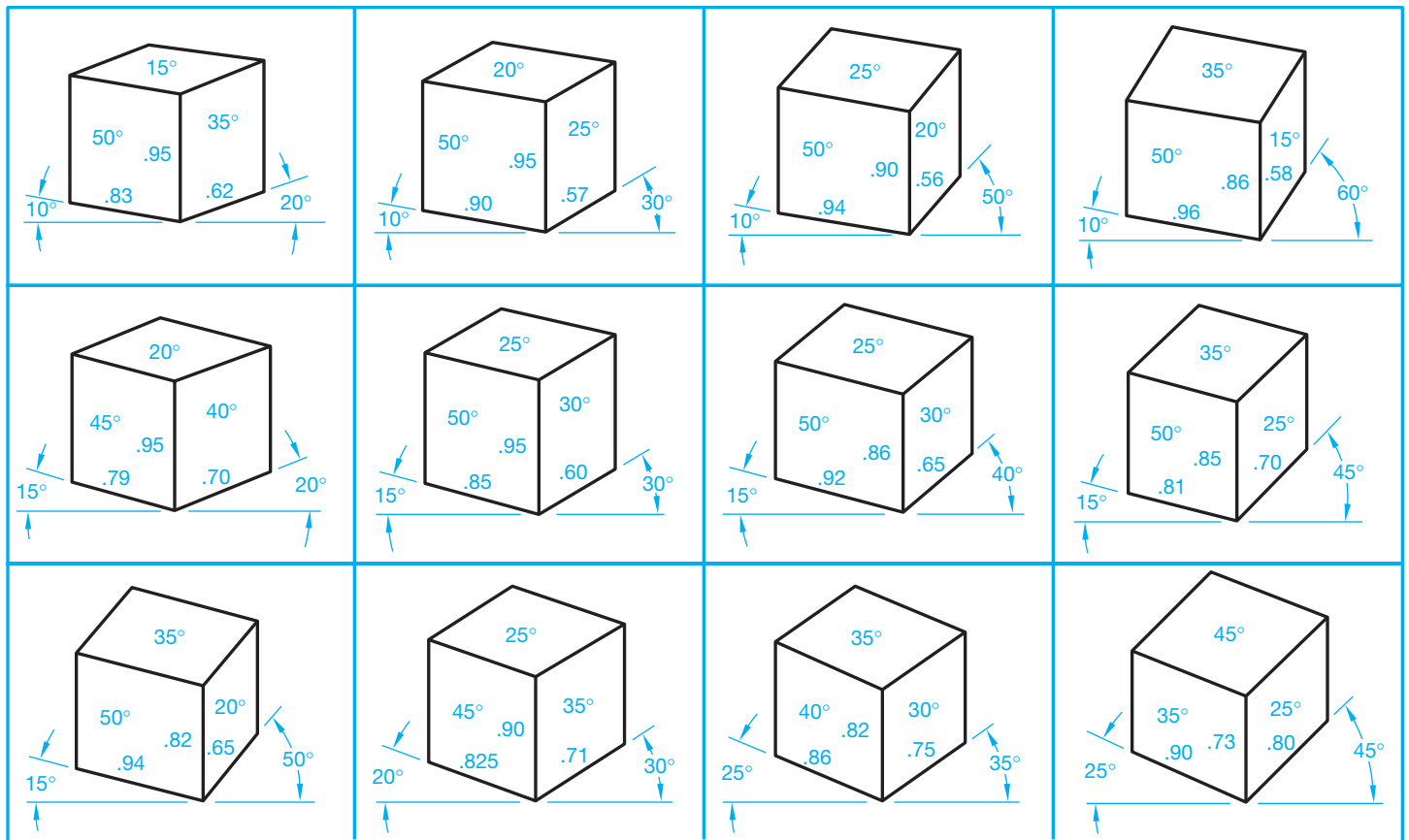


FIGURE 14.29 Common approximate trimetric angles, scales, and ellipse angles. © Cengage Learning 2012

Trimetric projection is similar to dimetric projection. Figure 14.29 shows some common approximate trimetric angles, scales, and ellipse angles.

## EXPLODED PICTORIAL DRAWING

Complicated parts and mechanisms are often illustrated as an exploded assembly in order to show the relationship of the parts in the most realistic manner. This type of drawing is commonly used in parts catalogs, owner's manuals, and assembly instructions (see Figure 14.30a).

An **exploded assembly** is a collection of parts, each drawn in the same axonometric method. Any of the pictorial drawing methods mentioned in this chapter can be used to create exploded assemblies, but isometric drawings are the most commonly used. The most important aspect of this type of drawing is to select the viewing direction that illustrates as much of the assembly as possible.

Centerlines are used in exploded views to show the connection between part and subassembly axis. Thin solid extension lines can be used to connect between noncylindrical features, parts, and subassemblies. These lines are called **connection lines** or **trails**. Trails aid the eye in following a part to its position in the assembly. Trails should avoid crossing other lines and parts. Lines should always be drawn parallel to the

axis lines of the drawing regardless of the drawing method selected. The neatest presentation is achieved by leaving gaps where the connection line intersects the part to which it applies and the mating feature. This is shown in Figure 14.31b. Some school or company standards prefer to draw parts as close together as clearly possible without the use of connection lines.

Depending on the purpose of the exploded isometric assembly, the parts can be drawn without identification as shown in Figure 14.30a and b, or they can be identified with **balloons**. A balloon is a circle placed on the drawing with a part identification number inside the circle. Although part identification on an exploded technical illustration commonly uses circles with numbers inside as balloons, some companies prefer to use numbers without circles. Each balloon is connected to its related part with a leader line. The balloon part identification number correlates to the same number identifying the part in the parts list. The parts list identifies every part in the assembly (see Figure 14.30c).

When drawing an exploded assembly with CADD or other illustration programs, it is not necessary to draw all the parts in their final positions. Draw each part as needed, placing construction lines for the connection lines. When all parts are completed, move them around as needed to construct the final layout.

## OBLIQUE DRAWING

**Oblique drawing** is a form of pictorial drawing in which the plane of projection is parallel to the front surface of the object. The lines of sight are at an angle to the plane of projection and are parallel to each other. This allows you to see three faces of the object. The front face, and any surface parallel to the front face, is shown in true size and shape, whereas the other two faces are at an angle. Oblique drawing is useful if one face of an object needs to be shown flat. Choose the orthographic face with the most curves and circles, because these are more difficult to draw on other surfaces at an angle.

There are three methods of oblique drawing: cavalier, cabinet, and general (see Figures 14.31 through 14.33).

### Cavalier Oblique

The **cavalier oblique** projection is one in which the receding lines are drawn true size or full scale. This form of oblique drawing is usually drawn at an angle of  $45^\circ$  from horizontal, which approximates a viewing angle of  $45^\circ$ . Because of the scale used

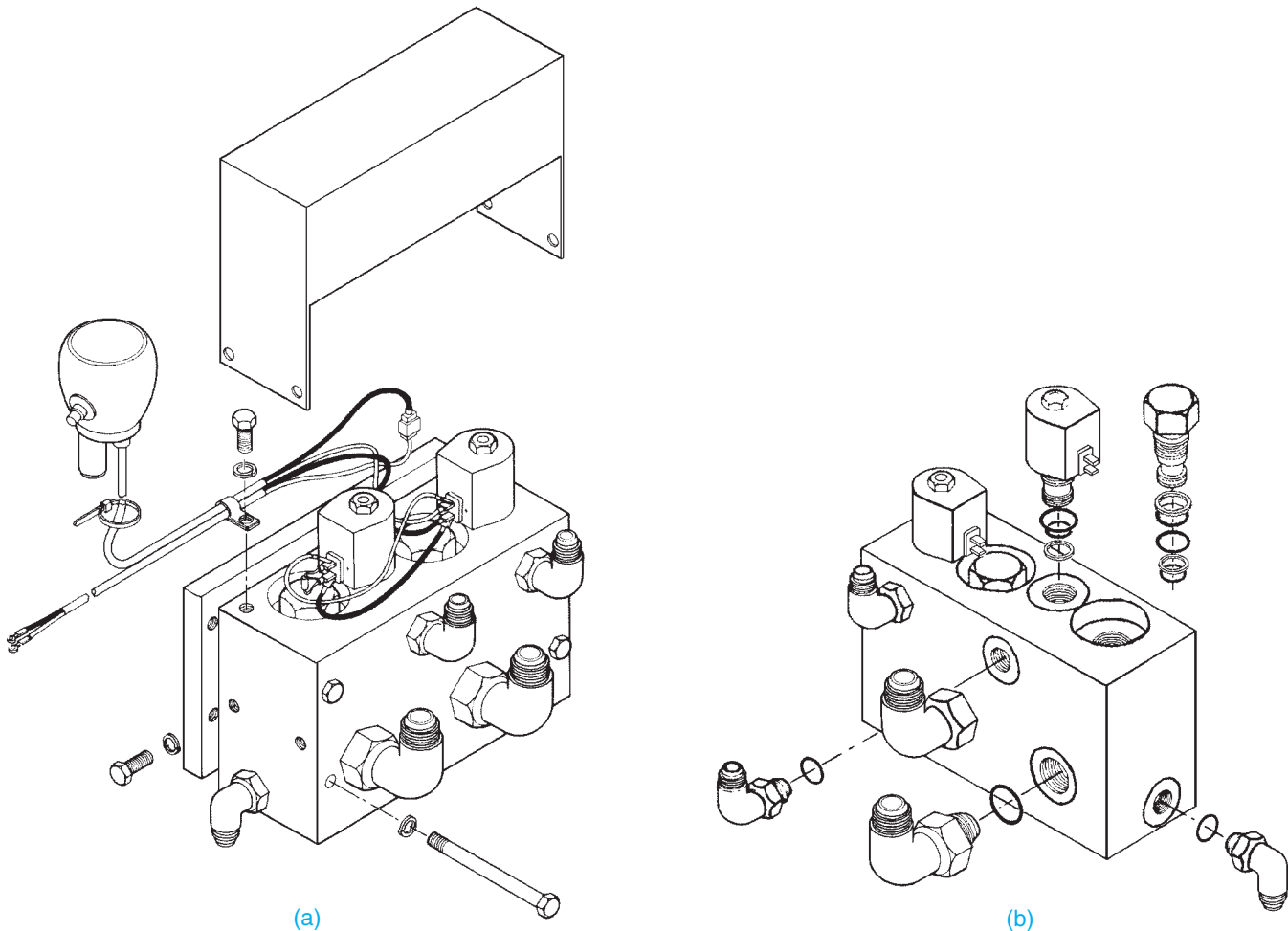
on the receding axis, it is not a good idea to draw long objects with the long axis perpendicular to the front face or projection plane. Objects that have a depth that is smaller than the width can be drawn in the cavalier form with clarity. Figure 14.31 shows an object drawn in cavalier oblique.

### Cabinet Oblique

A **cabinet oblique** drawing is also drawn with a receding angle of  $45^\circ$ , but the scale along the receding axis is half size. Objects having a greater depth than width can be drawn in this form with clarity. Cabinetmakers often draw their cabinet designs using this type of oblique drawing. A cabinet drawing is shown in Figure 14.32.

### General Oblique

The **general oblique** drawing is normally drawn at an angle other than  $45^\circ$ , and the scale on the receding axis is also different from those used in cavalier and cabinet drawings. The



**FIGURE 14.30** (a) and (b) Exploded assemblies without balloons and parts list. (c) An exploded assembly with balloons, parts list, and assembly notes.

Courtesy Industrial Illustrators, Inc.



SERVICE PARTS LIST

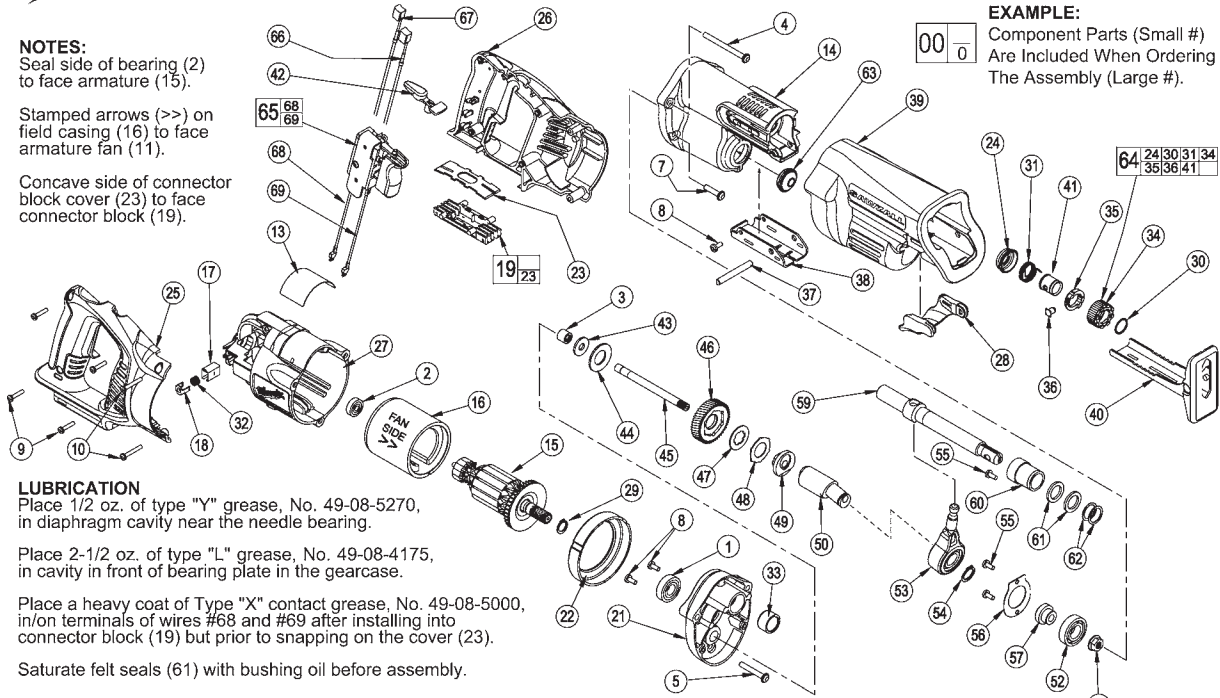
BULLETIN NO.  
54-40-7001

SPECIFY CATALOG NO. AND SERIAL NO. WHEN ORDERING PARTS		REVISED BULLETIN	DATE
CORDLESS SAWZALL®		54-40-7000	April 2005
CATALOG NO.	0719-20	WIRING INSTRUCTION SEE REVERSE SIDE	
STARTING SERIAL NO.	A56B		

**NOTES:**  
Seal side of bearing (2) to face armature (15).

Stamped arrows (>>) on field casing (16) to face armature fan (11).

Concave side of connector block cover (23) to face connector block (19).



**EXAMPLE:**  
Component Parts (Small #)  
Are Included When Ordering  
The Assembly (Large #).

**LUBRICATION**

Place 1/2 oz. of type "Y" grease, No. 49-08-5270, in diaphragm cavity near the needle bearing.

Place 2-1/2 oz. of type "L" grease, No. 49-08-4175, in cavity in front of bearing plate in the gearcase.

Place a heavy coat of Type "X" contact grease, No. 49-08-5000, in/on terminals of wires #68 and #69 after installing into connector block (19) but prior to snapping on the cover (23).

Saturate felt seals (61) with bushing oil before assembly.

FIG.	PART NO.	DESCRIPTION OF PART	NO. REQ.
1	02-04-0719	Ball Bearing	(1)
2	02-04-5130	Ball Bearing	(1)
3	02-50-2150	Needle Bearing	(1)
4	05-88-0302	K50 x 60mm Washer Hd. PT Screw	(2)
5	05-88-8309	K50 x 35mm Washer Hd. PT Screw	(2)
7	06-82-5363	8-32 x 1 Washer Hd. Tapitite T-20 Screw	(2)
8	06-82-7253	8-32 x .38 Tapitite T-20 Screw	(3)
9	06-82-7261	6-19 x .687 Slotted Plastite T-15 Screw	(4)
10	06-82-7276	6-19 x 1.00 Slotted Plastite T-15 Screw	(2)
13	12-20-0719	Service Nameplate Kit	(1)
14	28-14-0999	Gearcase	(1)
15	16-01-2121	Service Armature	(1)
16	18-01-2120	Service Field	(1)
17	22-20-0860	Brush Tube	(2)
18	22-32-0400	Brush Spring Clip	(2)
19	22-56-0975	Connector Block Assembly	(1)
21	28-28-0719	Diaphragm	(1)
22	31-05-0719	Baffle	(1)
23	-----	Connector Block Cover	(1)
24	31-15-0511	Spring Cover	(1)
25	31-44-0718	Right Handle Half	(1)
26	31-44-0719	Left Handle Half	(1)
27	31-50-0019	Motor Housing	(1)
28	31-52-0090	Shoe Release Lever	(1)
29	34-60-0920	External Retaining Ring	(1)
30	34-60-3680	Retaining Ring	(1)
31	40-50-0161	Torsion Spring	(1)
32	40-50-8840	Brush Spring	(2)
33	42-24-0620	Rear Spindle Bearing	(1)
34	42-50-0076	Front Cam	(1)
35	42-50-0077	Rear Cam	(1)
36	44-60-0626	Lock Pin	(1)
37	44-60-1635	Shoe Pin	(1)
38	44-66-0880	Shoe Retainer	(1)
39	45-12-0999	Gearcase Insulator	(1)
40	45-16-0645	Shoe Assembly	(1)
41	45-22-0081	Sleeve	(1)
42	45-24-0719	Lock Off Lever	(1)
43	45-88-1555	Washer	(1)
44	40-50-8850	Disc Spring	(1)
45	42-12-0155	Wobble Shaft Axel	(1)
46	32-40-0719	Intermediate Gear	(1)
47	43-06-0685	Metal Plate	(1)
48	43-06-0676	Bronz Plate	(1)
49	43-78-0525	Drive Hub	(1)
50	36-92-0502	Wobble Shaft	(1)

\* = Part number change from previous service parts list.

FIG.	PART NO.	DESCRIPTION OF PART	NO. REQ.
★ 52	02-04-1510	Ball Bearing	(1)
★ 53	14-67-0135	Wobble Plate Assembly	(1)
54	34-60-1315	Retaining Ring	(1)
★ 55	06-82-7253	8-32 x 3/8" Pan Hd. Slit. Tapitite T-20	(3)
56	44-86-0055	Bearing Retainer	(1)
57	45-36-1445	Spacer	(1)
58	06-55-3790	5/16-24 Spinlok Hex Nut	(1)
59	38-50-0680	Reciprocating Spindle	(1)
60	42-24-0610	Front Spindle Bearing	(1)
61	45-06-0501	Felt Seal	(2)
62	45-88-8577	Washer	(2)
63	42-52-0380	Bearing Cap	(1)
64	14-46-1011	Steel Quik-Lok Blade Clamp Kit	(1)
65	23-66-1719	Switch Assembly	(1)
66	22-18-1719	Carbon Brush Assembly - Black	(1)
67	22-18-0719	Carbon Brush Assembly - Red	(1)
68	23-94-0016	Leadwire Assembly - Black	(1)
69	23-94-0015	Leadwire Assembly - Red	(1)

**NOTES:**

Press rear spindle bearing (33) flush to -.030 from front exterior face in diaphragm boss (21).

Torque spinlok hex nut (58) to 180 in./lbs. to 210 in./ lbs.

Needle bearing (3) is to be pressed from the open end flush to ±.005 to face of bearing boss of diaphragm (21).

Remove brush tubes (17) prior to removing armature assembly (15) from motor housing (27).

Install brush tubes (17) into motor housing (27) only after armature assembly (15) has been secured into motor housing (27).

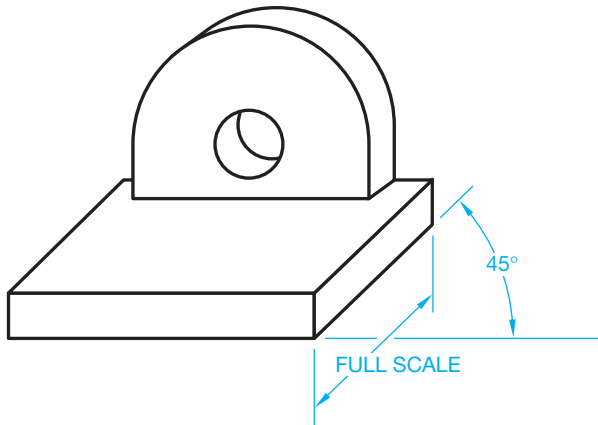
MILWAUKEE ELECTRIC TOOL CORPORATION  
13135 W. LISBON RD., BROOKFIELD, WI 53005

Drwa. 1

Courtesy Milwaukee Electric Tool Corporation

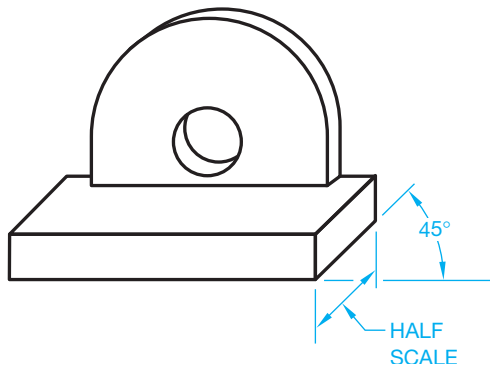
FIGURE 14.30 (Continued)





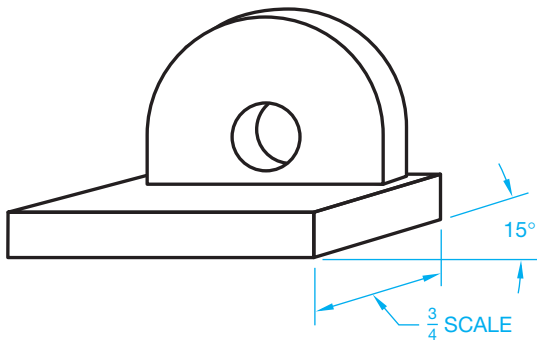
© Cengage Learning 2012

FIGURE 14.31 Cavalier oblique.



© Cengage Learning 2012

FIGURE 14.32 Cabinet oblique.



© Cengage Learning 2012

FIGURE 14.33 General oblique.

most common angles for a general oblique drawing are 30°, 45°, and 60°, but any angle can be used. Any scale from half to full size can be used. A general oblique drawing is shown in Figure 14.33.

## PERSPECTIVE DRAWING

Perspective drawing is the most realistic form of pictorial illustration. Perspective drawings give the representation of objects appearing smaller the farther away they are until they vanish

at a point on the horizon. Lines drawn parallel to the principal orthographic planes appear to converge on a vanishing point in perspective drawing.

Three types of perspective drawing techniques take their names from the number of vanishing points used in each. **One-point** or **parallel perspective** has one vanishing point and is used most often when drawing interiors of rooms. **Two-point** or **angular perspective** is the most popular, and it is used to illustrate exteriors of houses, small buildings, civil engineering projects, and, occasionally, machine parts. The third type of perspective is **three-point perspective**, which has three vanishing points and is used to illustrate objects having great vertical measurements, such as tall buildings. It is a lengthy process to draw a three-point perspective, so it is not used as often as two-point perspective.

The following discussions cover the construction of perspective drawings using construction methods. Keep in mind that once an object is drawn in 3-D using most CADD systems, it can be automatically displayed in a perspective format.

## General Perspective Drawing Concepts

Two principal components of a perspective drawing are (1) the eye of the person viewing the object and (2) the location of the person in relation to the object. The eye level of the observer is the **horizon line (HL)**. This line is established in the elevation (front) view (see Figure 14.34). The position of the observer in relation to the object is the **station point (SP)** and is established in relation to the plan (top) view. The location of the station point determines how close the observer is to the object and the angle at which the observer is viewing the object. The **ground line (GL)** is the line on which the object rests. The **picture plane (PP)**, or plane of projection, is the surface, or drawing sheet, on which the object is projected. The picture plane can be placed anywhere between the observer and the object. The picture plane can also be located beyond the object. The observer's lines of sight, or visual projection lines, determine what shows on the picture plane and where it shows on the picture plane. Finally, the three vanishing points discussed in the following sections are referred to as **vanishing point right (VPR)**, **vanishing point left (VPL)**, and **vanishing point vertical (VPV)**.

## DRAWING A ONE-POINT PERSPECTIVE

One-point perspective, also known as parallel perspective, has only one vanishing point. The plan view is oriented so the front surface of the object is parallel to the picture plane. The elevation view is placed below and to the right or left of the plan and rests on the ground line. The following steps allow you to construct a one-point perspective. Refer to Figure 14.35 as you read these instructions:

**STEP 1** Use construction lines for all work except the final object, which is thick object lines or shading

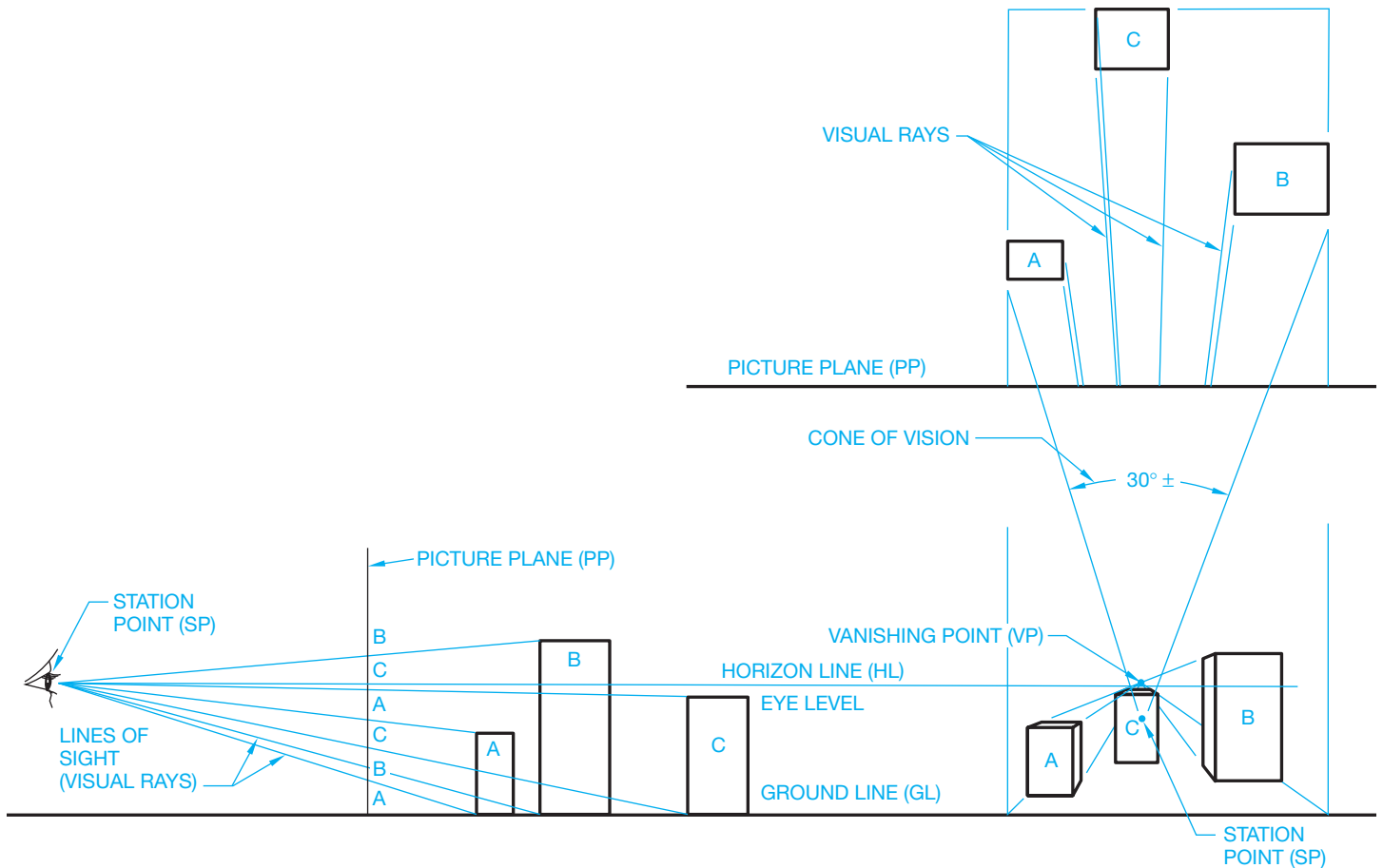


FIGURE 14.34 Principal components of perspective drawings. © Cengage Learning 2012

techniques. Locate the station point between the picture plane and the elevation view of the object. The station point can be anywhere, depending on the part of the object you want to view. The visual projection lines from the station point to the extreme corners of the object should form an included angle of approximately 30° to provide the most realistic perspective (see Figure 14.35).

- STEP 2** Determine the eye level of the observer in the elevation view. If you want to look over the object to see the top surface, the horizon line should be drawn above the elevation view. The horizon line can be drawn at any eye level. Constructing the horizon line at 5'6" above the ground line provides an eye level at approximately the average height of a person.
- STEP 3** The vanishing point is located on the horizon line directly in line with the station point.
- STEP 4** Project all points touching the picture plane, in the plan view, to the corresponding points in the elevation view.
- STEP 5** Draw visual projection lines from the station point to the rear corners of the object in the plan view.

- STEP 6** The points where the visual projection lines intersect the picture plane are projected vertically down to the perspective view. When drawing complex objects, work with only a portion of these points at one time to avoid confusion.
- STEP 7** Project points A, B, and C toward the vanishing point to intersect the corresponding projectors from the picture plane. Now draw the horizontal line B'C'. Any line that is parallel to the PP in the plan view must be parallel to the GL in the perspective view.
- STEP 8** Project the height of the object from the elevation view to points D and E on the two true-height lines (THL). True-height lines are projected from points touching the PP.
- STEP 9** Project the height at points D and E back toward the vanishing point to intersect the projectors from the rear portion of the object in the plan view.
- STEP 10** Complete the object by connecting the ends of the sloping portion and projecting the base of the sloped feature toward the vanishing point as shown in Figure 14.35.

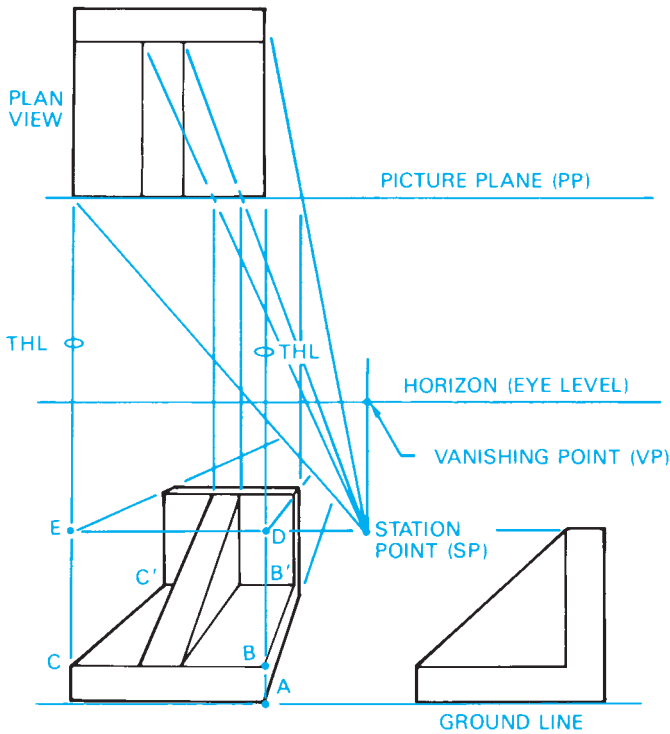


FIGURE 14.35 Constructing a one-point perspective drawing. © Cengage Learning 2012

### DRAWING A TWO-POINT PERSPECTIVE

The two-point perspective method is also called *angular perspective* because it is turned so two of its principal planes are at an angle to the picture plane. This is the most popular form of perspective drawing. Two vanishing points allow parallel lines on the two principal planes to be projected in two directions, giving another dimension to the depth of the perspective.

The same one-point perspective object is used in this example. The object has been positioned at an angle in the plan view, with one corner touching the PP. The elevation view, SP, HL, and GL have all been established. Refer to Figure 14.36 as you read these instructions.

- STEP 1** Draw a line from the station point (SP), parallel to each side of the object in the plan view, to intersect the PP.
- STEP 2** Project the points on the PP down to the HL. This establishes vanishing point right (VPR) and vanishing point left (VPL) on the horizon line.
- STEP 3** Project point A on the PP down to the GL. This becomes the true-height line AB in the perspective view.
- STEP 4** Begin blocking in the object by projecting points A and B to the two vanishing points. This establishes the two angular, or perspective, sides of the object.
- STEP 5** Project visual projection lines from the SP to the extreme corners of the object in the plan view.
- STEP 6** Project the intersection of the visual projection lines with the PP down to intersect with the projectors

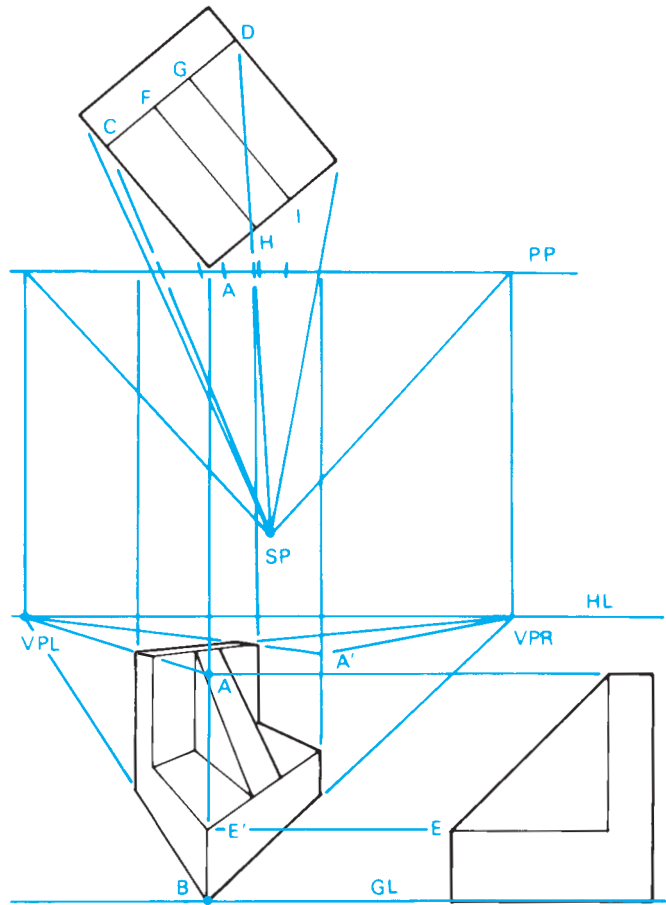


FIGURE 14.36 Constructing a two-point perspective drawing. © Cengage Learning 2012

from points A and B to the two vanishing points. This blocks in the two sides of the object.

- STEP 7** Draw lines from the SP to points C and D. Where these lines intersect the PP, project vertical lines down into the perspective view. The height of the object at points A and A' can now be projected toward the VPL to intersect with the projectors from points C and D.
- STEP 8** The height at E can be projected to E' on the THL. Project E' toward both vanishing points to create the basic shape of the object.
- STEP 9** Project points F, G, H, and I to the station point. Where these lines intersect the PP, drop vertical projectors down to the perspective view. These lines will intersect corresponding points on the perspective drawing. Connect the points as shown in Figure 14.36 to complete the perspective view.

### DRAWING A THREE-POINT PERSPECTIVE

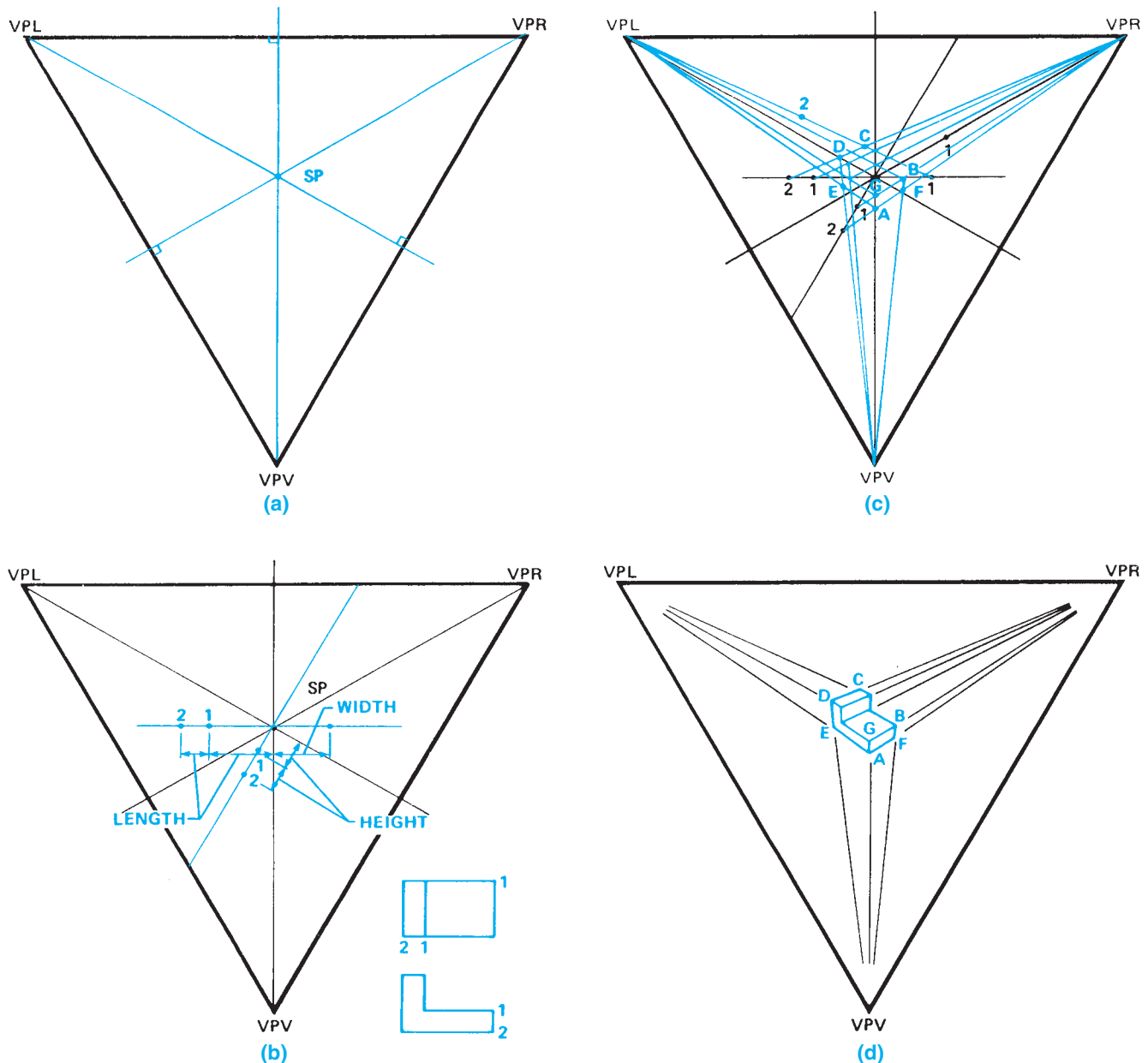
Three vanishing points are used in three-point perspective drawings. Three-point perspective drawings require more time to construct than two-point perspectives and often occupy a

considerable area on the drawing sheet. Three-point perspective drawings are used when certain effects are needed for visual simulation of an object such as a tall building. The method of constructing a three-point perspective that requires the least amount of drawing space is used in the following example. Refer to Figure 14.37 as you read these instructions.

- STEP 1** Draw an equilateral triangle to occupy as much of the sheet as possible. Label the three corners as vanishing points VPR, VPL, and VPV.
- STEP 2** Construct perpendicular bisectors of each of the three sides. Their intersection at the center of the triangle is labeled SP (station point) (see Figure 14.37a).

**STEP 3** Draw a horizontal line through the SP. Measure and mark the length of the object to the left of the SP. Measure and mark the width of the object to the right of the SP. This allows you to draw an object in perspective as if you turned the plan view 45° to the picture plane line (see Figure 14.37b).

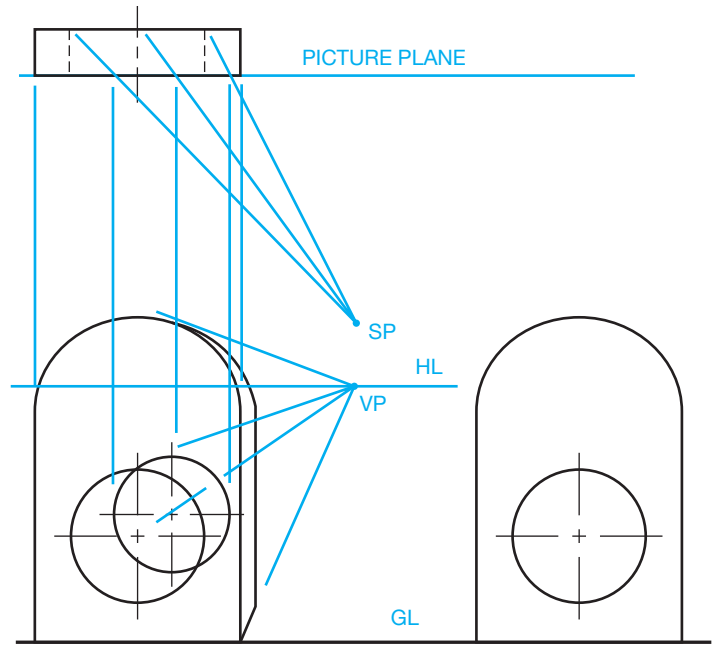
**STEP 4** Draw a line parallel to line VPV, VPR. This becomes the height measuring line. Measure the height of the object from the SP down to the left along this line as shown in Figure 14.37b. Numbers have been placed at intervals along the measuring lines. These indicate measurements of features on the object.



**FIGURE 14.37** Constructing a three-point perspective drawing. (a) Establishing vanishing points and the station point. (b) Establishing the length, width, and height of the object. (c) Establishing the outline of the object. (d) The completed object.

**STEP 5** Project lines from points 1 and 2 to the left of the SP to VPR. Next, draw a line from point 1 at the right of the SP to VPL. Draw lines from points 1 and 2 on the height measuring line VPR (see Figure 14.37c). You have now blocked in the overall measurements of the object. The following points have been located: lower-front corner (A), upper-right corner (B), upper-far corner (C), and upper-left corner (D). Notice in Figure 14.37c that the SP is the upper-front corner of a box enclosing the object.

**STEP 6** Project points B and D to VPV, then project A to VPR and VPL. The intersections of these lines are points E and F, the lower-left and lower-right corners, respectively. Point G is the height of the front corner of the object as shown in Figure 14.37c. Keep in mind that any surface of the object parallel to one of the principal planes of the orthographic view must project to one of the vanishing points as you draw the remainder of the object features. The completed object is shown in Figure 14.37d.

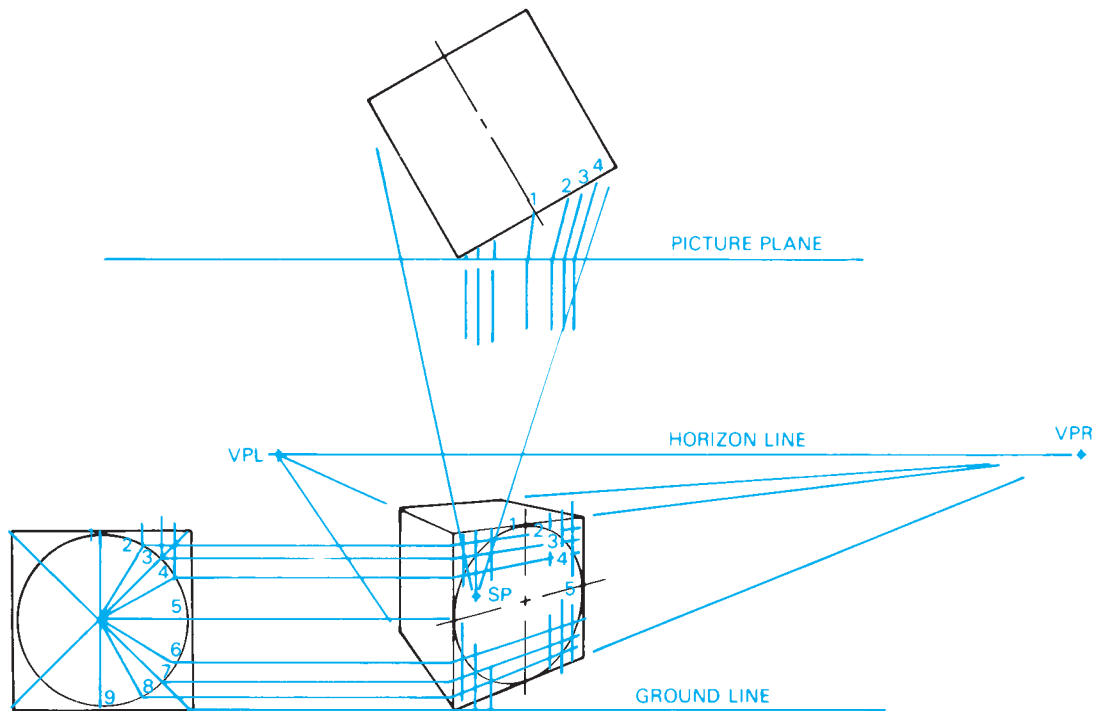


**FIGURE 14.38** Circles in surface parallel to the picture plane. © Cengage Learning 2012

### DRAWING CIRCLES AND CURVES IN PERSPECTIVE

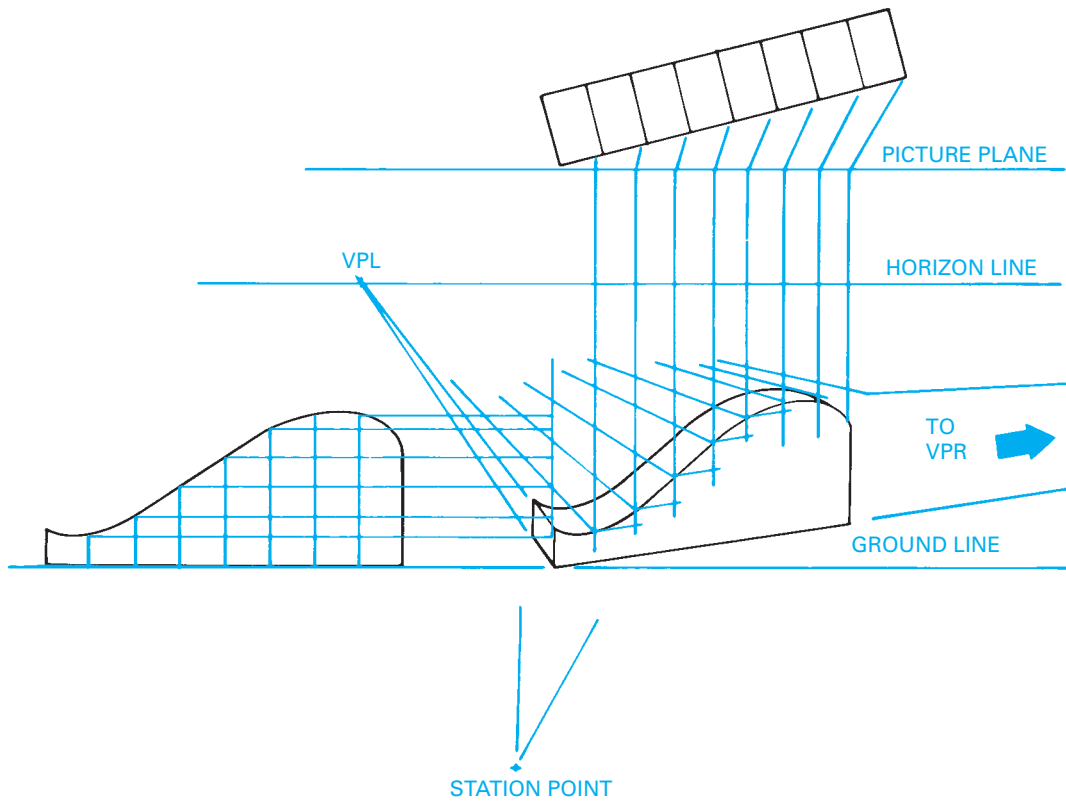
In most cases, circles in perspective appear as ellipses. But if a surface of an object is parallel to the picture plane, then any circle on that surface appears as a circle (see Figure 14.38). Circles located in planes at an angle to the picture plane appear as ellipses and can be drawn by a method of intersecting lines projected from the elevation and plan view, which is referred to as the *coordinate method*.

The object having the circles is drawn first in plan and elevation, and all of the necessary lines and points for the perspective drawing are determined and placed on the drawing (see Figure 14.39). Next, divide the circle in the elevation view into a convenient number of pie-shaped sections. Project the intersections of these section lines with the circle to the top and side



**FIGURE 14.39** Circles plotted in perspective by the coordinate method.

© Cengage Learning 2012



**FIGURE 14.40** Irregular curve plotted in perspective by the coordinate method.

© Cengage Learning 2012

of the object. The points along the side of the object are then projected onto the perspective view. Now transfer the distances formed by the intersection of the top of the object and the lines projected from the pie-shaped sections in the elevation view to the plan view. Next, draw visual projection lines from the SP to the points in the plan view. Where the visual projection lines intersect the picture plane line, project the points straight to the perspective view. These projectors intersect the ones drawn from the elevation view. Connect these intersection points with the appropriately sized ellipse.

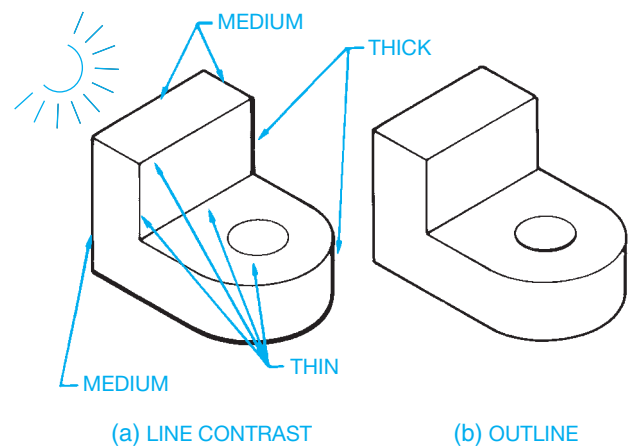
The same method can be used to draw irregular curves. Establish a grid, or coordinates, on the curve in the elevation view and place the same divisions on a plan view. Project these two sets of coordinates to the perspective view and then draw a curve to connect the points (see Figure 14.40).

## USING BASIC SHADING TECHNIQUES

A variety of shading techniques can be used to enhance your pictorial drawings. The methods discussed in the following are basic line and block shading. Illustrators, graphic artists, and industrial designers often use tools including pencil, paper, markers, and computers with specialized hardware and software. Traditional pencil and paper with color markers are commonly used in a creative and artistic manner for many pictorial drawings. Airbrush tools also are used for shading applications. The illustrator uses a light touch for layout and harder pressure for solid lines and forms when working on the electronic tablet.

## Using Line Shading

Most pictorial drawings are created to illustrate shape description and to show the relationship of parts in an assembly. The objects shown in Figure 14.41 illustrate a basic form of shading, called **line-contrast shading**. Vertical lines opposite the light source and along bottom edges of the part are drawn with thick lines. Some illustrators outline the entire object in a thick line to make it stand out as shown in Figure 14.41b.



**FIGURE 14.41** Line-contrast shading. (a) Line contrast shading. (b) Line contrast outline shading.

© Cengage Learning 2012

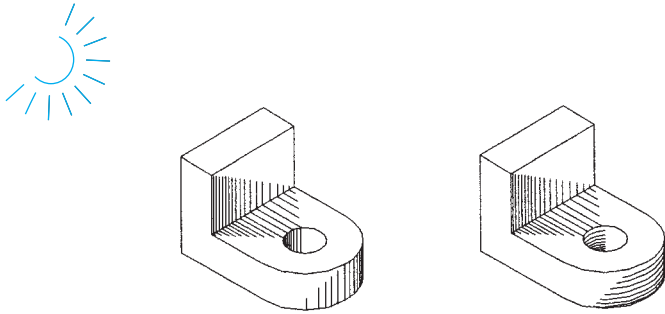


FIGURE 14.42 Straight line shading. © Cengage Learning 2012

**Straight line shading** is a series of thin straight lines that can be varied to achieve any desired shading effect. Straight lines can be used on flat and curved surfaces. Notice in Figure 14.42 the two ways that straight lines can be used on curved surfaces, and the effect of straight line shading on the flat surfaces. The idea is to imagine how an object is shaded by a light source placed at a desired location and then to create the shading as you visualize.

Additional emphasis can be given to curved surfaces with the use of **block shading**. Figure 14.43 shows how block shading on one or both sides of a curved surface can produce a highlight effect. One to three lines of shading are normally used to achieve the block shading effect. The total amount of block shading should be approximately one-third the width of the feature as shown in Figure 14.43.

Another type of shading is called **stipple shading**, which is the use of dots to create a shading effect (see Figure 14.44). The closer the dots are placed to each other, the darker the shading looks. Although stippling takes longer than line shading, the results can be pleasing.

### Representing Fillets and Rounds in Pictorial Drawings

**Fillets** and **rounds** can be represented in three ways as shown in Figure 14.45. Figure 14.45a uses three thin lines to indicate the

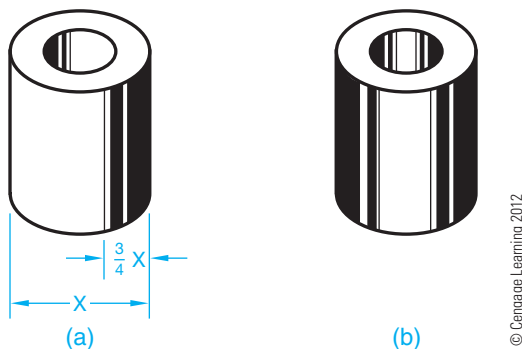


FIGURE 14.43 Block shading. (a) Recommended shading dimensions. (b) A completely shaded cylindrical object.

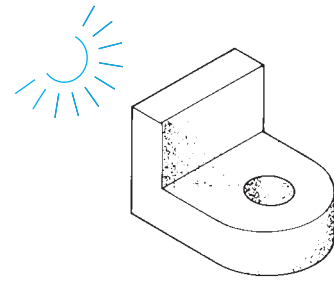


FIGURE 14.44 Stipple shading.

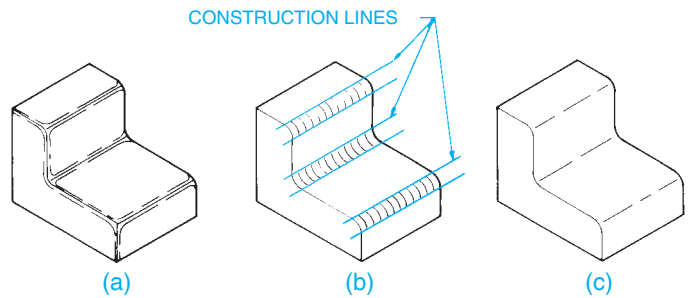


FIGURE 14.45 Depicting fillets and rounds. Showing shading application on fillet and round contours. (a) Using line segments to represent fillet and round contours. (b) Using small arc segments to show fillet and round contours. (c) Single line segments used to show fillet and rounds. © Cengage Learning 2012

two outside edges or tangent points of the radius and the centerline of the radius. Notice the occasional gaps in the outside line, giving a contour effect.

With the technique in Figure 14.45b, the same size elliptical arc is moved along the axis of the radius and repeated at regular intervals. It is important to draw construction lines first for the outside edges of the fillet or round. This ensures that all of the elliptical arcs are aligned. Draw the elliptical arcs with a thin line. The example shown in Figure 14.45c is the simplest method for showing fillets and rounds and requires the least amount of time to draw. This method uses a broken line drawn along the axis of the radius to indicate the curved surface.

### PICTORIAL DRAWING LAYOUT TECHNIQUES

The best way to begin any pictorial drawing, especially if you are working from an orthographic (multiview) drawing, is to make a quick sketch. This allows you to see the part in a 3-D form before you try to create a formal drawing.

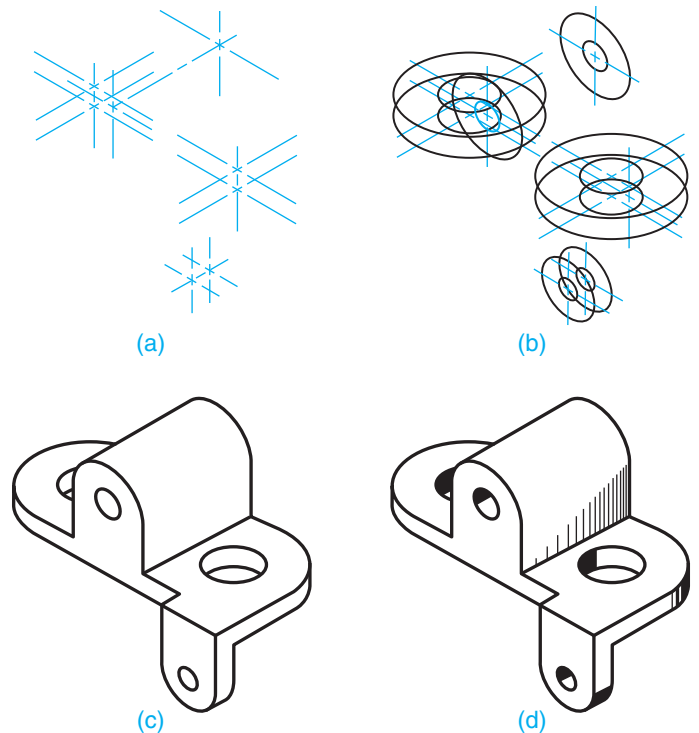
Objects that have rectangular or angular shapes should be drawn by first laying out the overall sizes of the part by boxing in the shape using construction lines. Then begin to cut away from the box using measurements from the part or drawing. This practice is called the **coordinate** or **box**

**method.** Use the following layout techniques if the object has circular features:

- STEP 1** Lay out the centerlines and axis lines of the circular features (see Figure 14.46a).
- STEP 2** Draw the circular features using ellipses with the centerlines as a guide (see Figure 14.46b).
- STEP 3** Join ellipse contours with straight lines (see Figure 14.46c).
- STEP 4** Add additional features such as shading, notes, and item tags. Notes or item tags can be added last. Edit the drawing so only the visible object lines show. If you created a construction layer for your CADD drawing, turn off this layer when the drawing is completed. The finished drawing is shown in Figure 14.46d.



**NOTE:** The previous content provided you with information and detailed instructions for drawing a variety of common types of pictorial drawings. It is important for you to understand the fundamental techniques involved in creating pictorial drawings. The methods described can be used when producing pictorial sketches or when using a standard 2-D CADD software program that has either limited or no 3-D CADD capabilities. Most pictorial drawings are completed using CADD or illustration programs that have powerful tools for creating any desired pictorial drawing or technical illustration.



**FIGURE 14.46** (a) Lay out centerlines and axis lines of circular features. (b) Draw circular features using ellipses. (c) Join ellipses with straight lines. (d) Complete the drawing with shading. © Cengage Learning 2012

## TECHNICAL ILLUSTRATION SOFTWARE

Most technical illustrations are now done with computer illustration programs. These programs range from a few hundred dollars to many thousands of dollars. Computer illustration programs greatly increase illustration efficiency. Electronic libraries of common parts such as screws, bolts, hardware, and tools also help the illustrator create illustrations quicker and with consistency. Functions such as drawing, trimming, rotating, copy and paste, and creating arrays of parts are why these programs are now used industry wide.

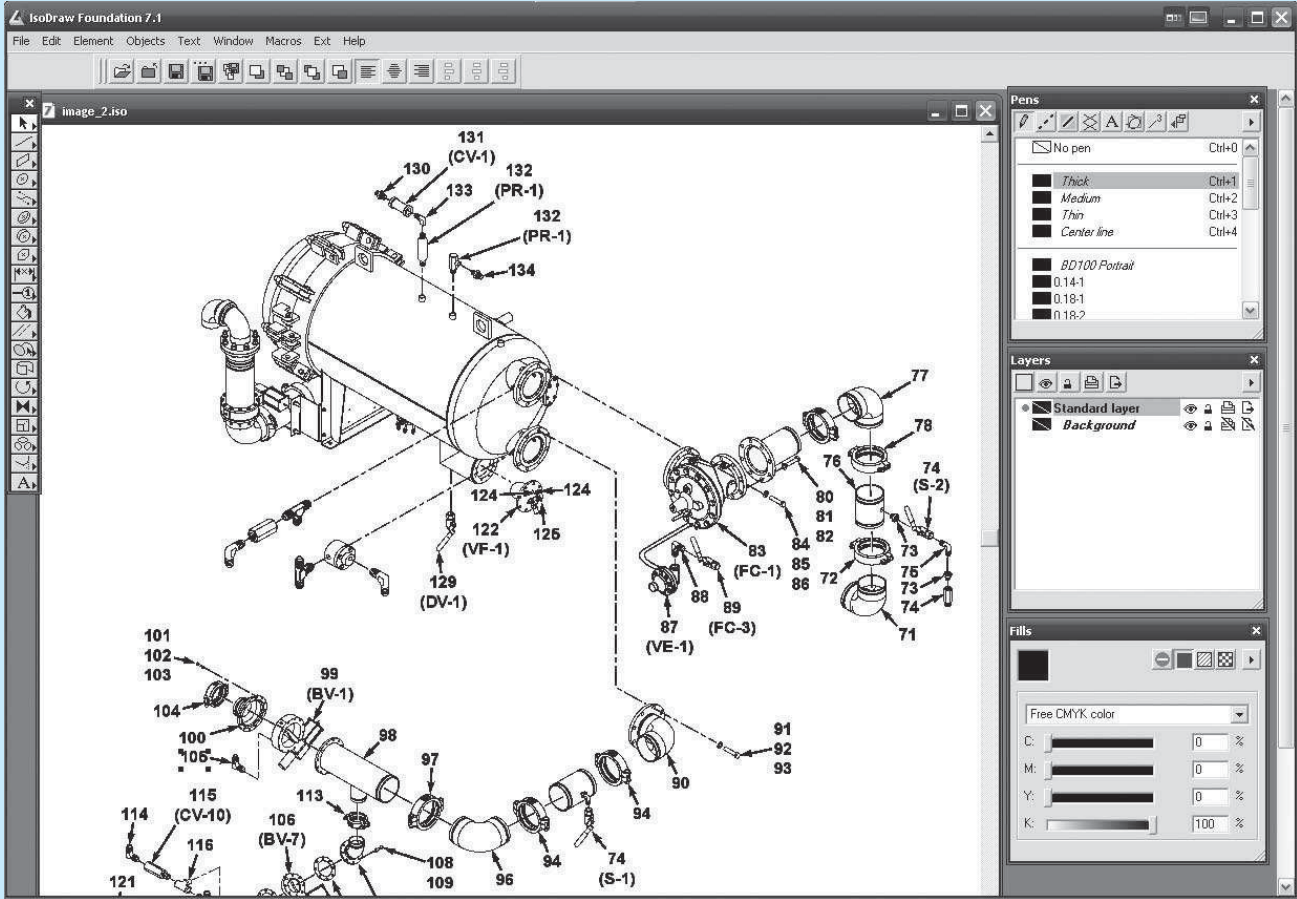
Illustrators no longer have to create ellipses, boxes, and circles using traditional construction methods. Drawn objects remain **live** and can be resized and copied as needed. The import functions of these programs allow them to open and edit files from a wide variety of CADD programs. Figure 14.47 shows a computer illustration program being used to create an exploded technical illustration.

These illustration programs allow re-editing of existing illustrations with minimal effort and allow files to be re-used as a starting point for new illustrations.

Some higher-end illustration software packages allow direct, **real-time** linking to the engineering model. *Real-time* refers to a computer program that creates events that are represented exactly as they occur. For example, the exact time of the application equals the time it takes to view the application (see Figure 14.48a). An example is a bicycle assembly used as a **locator**. This assembly can be linked to the master engineering model so that each time the illustration is opened, the model link is updated. A locator is the fully assembled view of a product usually shown in the upper left of the page, with an exploded sub assembly as shown in Figure 14.48b. These programs have export functions that allow illustrators to supply formats used for many electronic publications. Common vector exports are .CGM and .EPS. Common raster export file types are .JPG, .TIF, and .PNG.

(Continued)





Courtesy O'Neil & Associates, Inc.

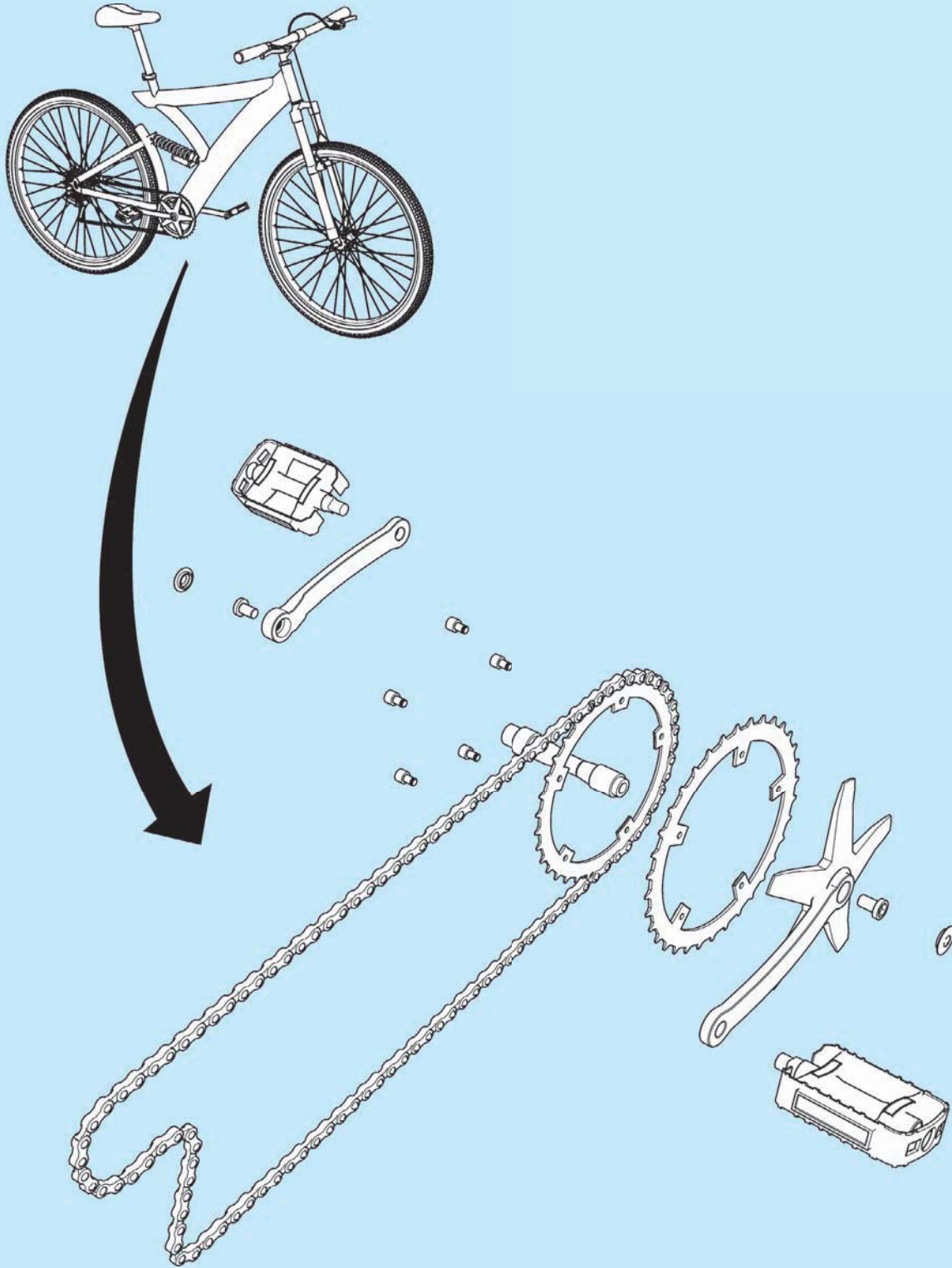
**FIGURE 14.47** A computer illustration program being used to create an exploded technical illustration.



(a)

**FIGURE 14.48** (a) Some software packages allow direct, real-time linking to the engineering model. (b) The bicycle locator is the fully assembled view shown in the upper left of the page, with an exploded sub assembly.

(Continued)



(b)

FIGURE 14.48 (Continued)

(Continued)

Courtesy O'Neil & Associates, Inc.

### THREE-DIMENSIONAL ILLUSTRATION CAPABILITIES

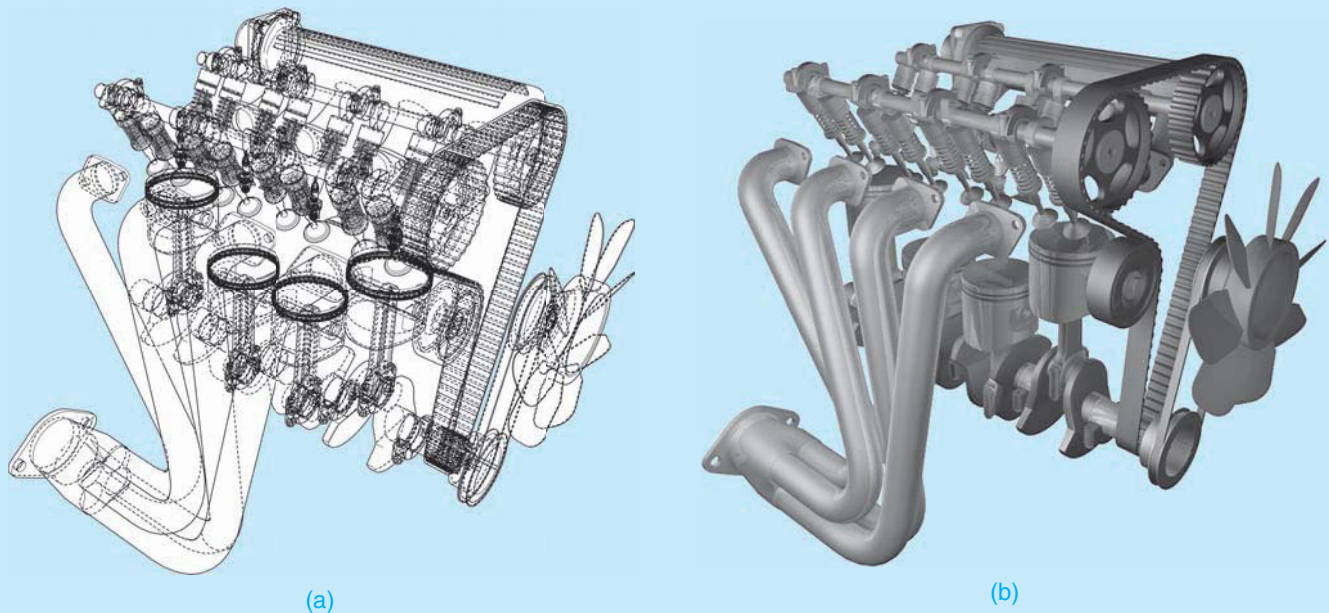
Many 3-D CADD techniques are given throughout this chapter where they apply to specific applications.

Computer-generated pictorial line drawings have given drafters, designers, and engineers the ability to draw an object once and then create as many different displays of that object as needed. Three-dimensional wire-form capabilities shown in Figure 14.49a are available with most commercial CADD systems.

Polygon-based 3-D programs such as Autodesk's Maya and Maxon's Cinema 4D can also be used to create accurate 3-D models for technical illustration purposes. These programs are not engineering 3-D programs, but they are very good at providing quick and accurate models for illustrations and photorealistic renderings and animations. These programs allow the designer or drafter to view the object as if it is constructed of wire as shown in Figure 14.49a, where all edges can be seen at the same time. The 3-D wire form is somewhat limiting because complex parts soon become a maze of lines. The surface form is a

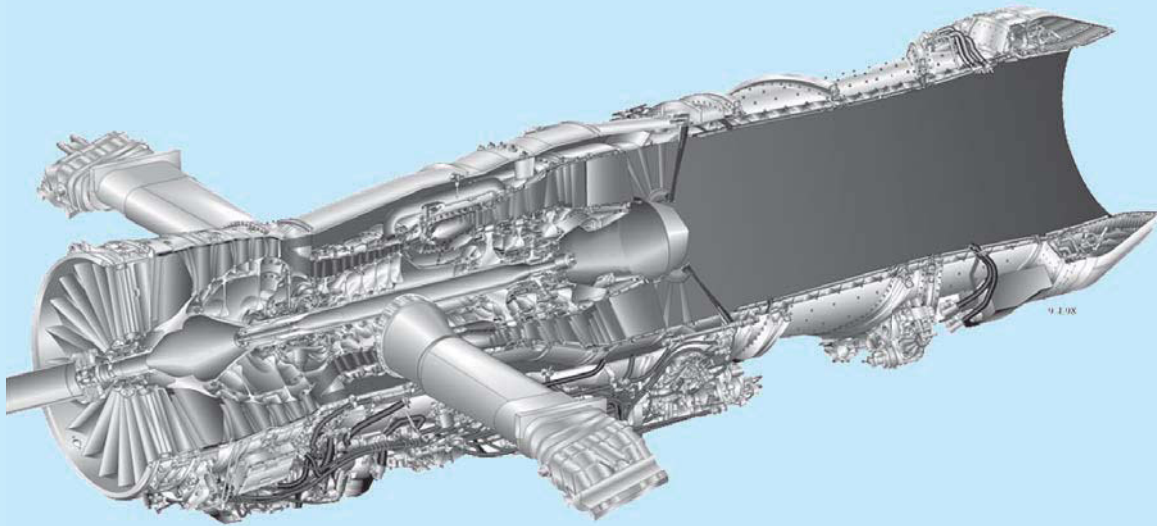
step closer to reality because it shows only the surfaces that would actually be seen. Figure 14.49b shows a fully rendered view of the same four-cylinder engine shown in Figure 14.49a.

The greatest realism in pictorial presentation can be achieved by CADD systems and 3-D animation programs that have color solid modeling capabilities. These applications are available in all illustration programs. CADD systems and 3-D animation systems allow you to draw the object, shade or color its different parts or surfaces, and rotate it in any direction desired. You can also cut into the object at any location to view internal features and then rotate it to achieve the best view. This screen display can then be made into a hard copy or video animation. Figure 14.50 shows a 3-D model of an engine cut away to view the internal features. The 3-D model shown in Figure 14.51 was created with Autodesk's Maya and animated to show the internal workings of an electric motor. This animation is used in an e-learning environment to explain the inner workings of electric motors. When using the animation, the student clicks through the animation to expose internal parts.



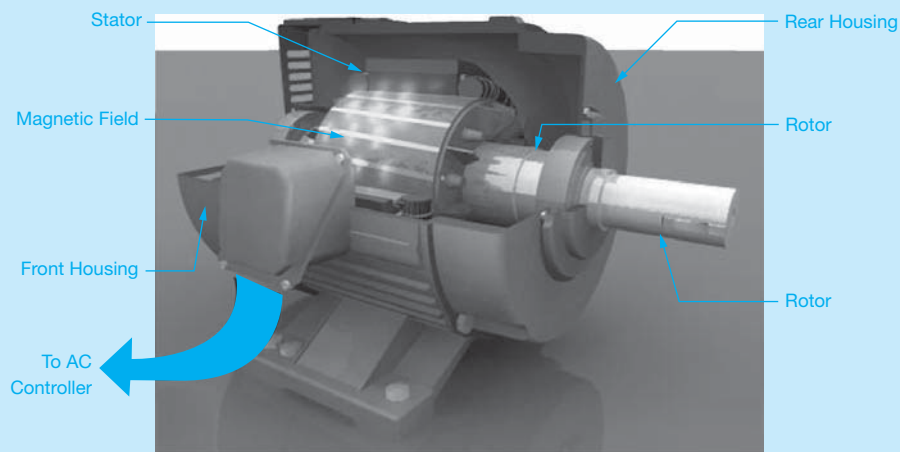
**FIGURE 14.49** (a) A typical four-cylinder, overhead cam combustion engine shown in wireframe. (b) A fully rendered view of the same four-cylinder engine. *Courtesy O'Neil & Associates, Inc.*

*(Continued)*



Courtesy O'Neil &amp; Associates, Inc.

**FIGURE 14.50** A 3-D model of an engine cut away to view the internal features.



Courtesy O'Neil &amp; Associates, Inc.

**FIGURE 14.51** A 3-D model animated to show the internal workings of an electric motor.

## PROFESSIONAL PERSPECTIVE

Pictorial drawing requires a good ability to visualize objects in 3-D form. Companies that produce parts catalogs, instruction manuals, and presentation drawings require the services of a technical illustrator or someone skilled in pictorial drawing. A part of your professional portfolio should be 8" × 10" photo reductions or laser prints of your best pictorial drawings.

The field of technical illustration is often more limited than engineering and drafting, but it is available for people with

talent. The area of industrial design, discussed in Chapter 25, is a great place for you to demonstrate your creative abilities and illustrative talents. Always keep examples of a variety of pictorial drawing types in your portfolio. Your portfolio should be professional looking and show examples of the different types of designs and drawings you have created. Manila pocket folders that fit into the binder are excellent for holding folded prints. Remember that often a small freelance job can lead to bigger jobs and maybe even to owning your own company.

An isometric drawing is constructed using the actual measurements of the part. But because isometric drawing does not take into account foreshortening, the object appears larger in the drawing than it is in reality. To compensate for this, isometric projection can be used to show the object in its foreshortened appearance. If a part measures 1 in. on a side, then a true isometric projection creates an isometric line measuring .816 in.

To construct an isometric view of an object that is a true isometric projection, it is necessary to multiply the actual measurements by .816 to get the drawing measurements. The following measurements are converted as follows:

$$1.45 \text{ in.} \times .816 = 1.183 \text{ in.}$$

$$3.67 \text{ in.} \times .816 = 2.995 \text{ in.}$$

$$.89 \text{ in.} \times .816 = .726 \text{ in.}$$



### 3-D Animation

To see and operate the 3-D animation of the electric motor shown in Figure 14.51, go to the Student CD, select **Supplemental Material, Chapter 14**, and then **3-D Animation of Electric Motor**.



### Engineering Drawing and Design Math Applications

For complete information and instructions for engineering drawing and design math applications, go to the Student CD, select **Reference Material** and **Engineering Drawing and Design Math Applications**.

## WEB SITE RESEARCH

The following Web sites can provide you additional information for research or further study into topics covered in this chapter.

Address	Company, Product, or Service
www.asme.org	Find information and publications related to the American Society of Mechanical Engineers
www.ansi.org	The American National Standards Institute. Information about national and international drafting standards
www.adda.org	American Design Drafting Association
www.nationalcadstandard.org	U.S. National CAD Standard
www.oneil.com	O'Neil & Associates, Inc.

# Chapter 14

## Chapter 14 Pictorial Drawings and Technical Illustrations Test



To access the Chapter 14 test, go to the Student CD, select **Chapter Tests and Problems**, and then **Chapter 14**. Answer the questions

with short, complete statements, sketches, or drawings as needed. Confirm the preferred submittal process with your instructor.

# Chapter 14 Pictorial Drawings and Technical Illustrations Problems

## INSTRUCTIONS

Choose the best axis to show as many features of the object as possible in your axonometric or oblique drawing. Problem assignments are presented as engineering designs or sketches and may not match proper ASME standards.

For axonometric problems—Problems 14.1 through 14.10—draw isometric, dimetric, or trimetric as assigned. For oblique problems—Problems 14.11 through 14.17—draw cavalier, cabinet, or general oblique as assigned. Remember that circular features are best shown in the front plane of the oblique view.

For perspective problems—Problems 14.18 through 14.25—make a one-, two-, or three-point perspective drawing as assigned except for Problem 14.18, which should be done as a one-point perspective view. All objects can be turned at any desired angle on the picture-plane line for viewing from the station point, except Problem 14.18, which should be drawn in the direction indicated.

1. Make a freehand sketch of the object to assist in visualization and layout of axonometric and oblique problems.
2. For axonometric and oblique problems, select a scale to fit the drawing comfortably on an A- or B-size (A4 or A3 metric) drawing sheet. Use a C- or D-size (A2 or A1 metric) drawing sheet for drawing an initial layout of the perspective problems on sketch paper or butcher paper.
3. Dimension axonometric or oblique problems only if assigned by your instructor. Do not place dimensions on a perspective view.
4. Perspective objects without dimensions can be measured directly on the given problem and scaled up as indicated or assigned.
5. Use an ASME standard border and sheet block, unless otherwise specified by your instructor.

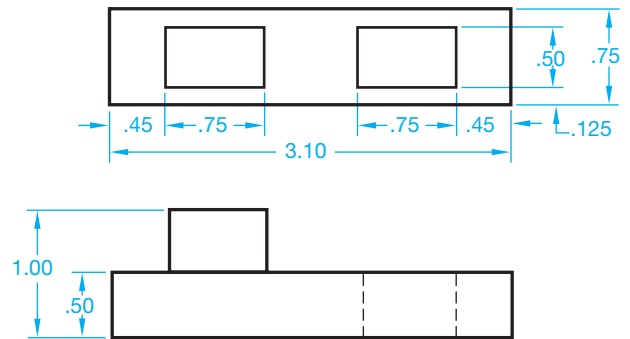


### Drafting Templates

To access CADD template files with predefined drafting settings, go to the Student CD, select **Drafting Templates**, and then select the appropriate template file.

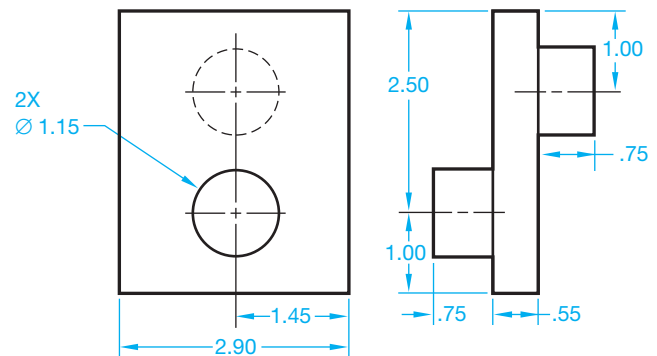
### Part 1: Problems 14.1 Through 14.5

#### PROBLEM 14.1 Axonometric projection (in.)



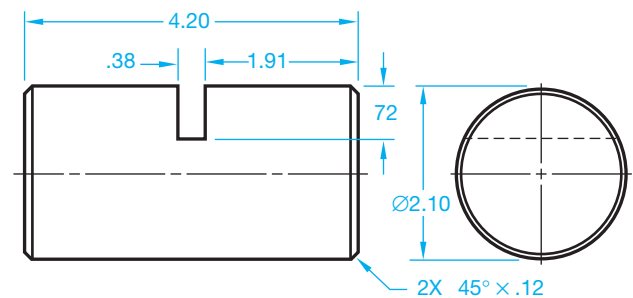
© Cengage Learning 2012

#### PROBLEM 14.2 Axonometric projection (in.)



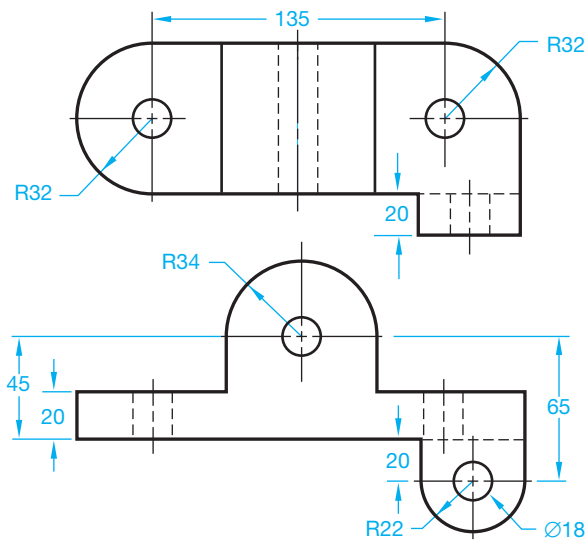
© Cengage Learning 2012

#### PROBLEM 14.3 Axonometric projection (in.)



© Cengage Learning 2012

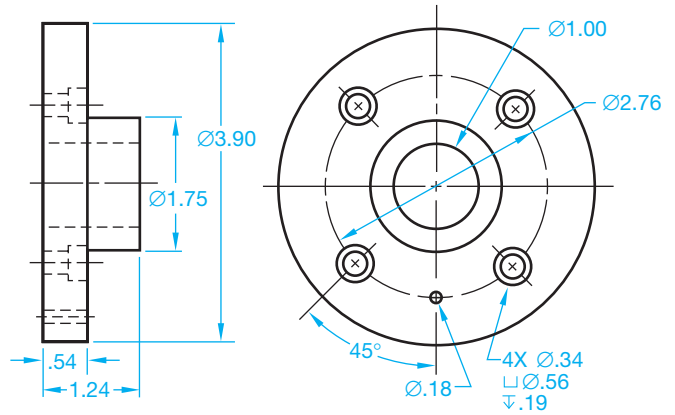
PROBLEM 14.4 Axonometric projection (metric)



© Cengage Learning 2012

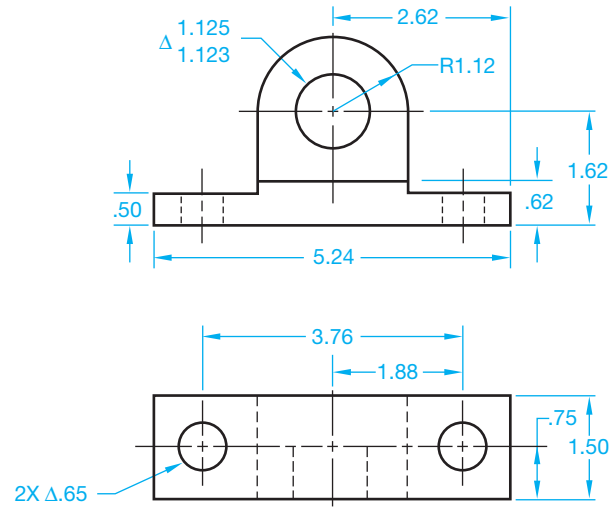
Part 3: Problems 14.11 Through 14.13

PROBLEM 14.11 Oblique projection (in.)



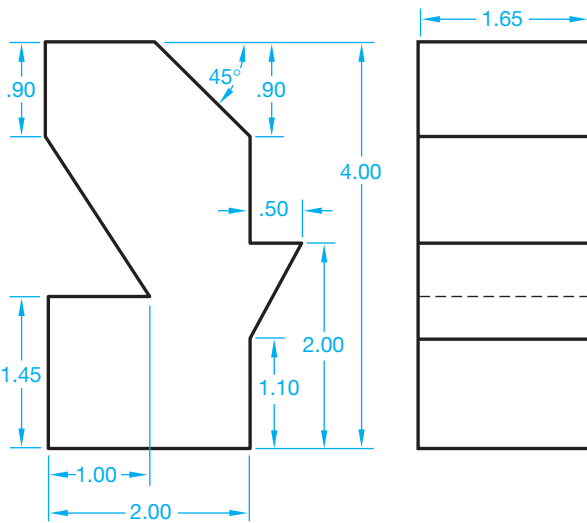
© Cengage Learning 2012

PROBLEM 14.12 Oblique projection (in.)



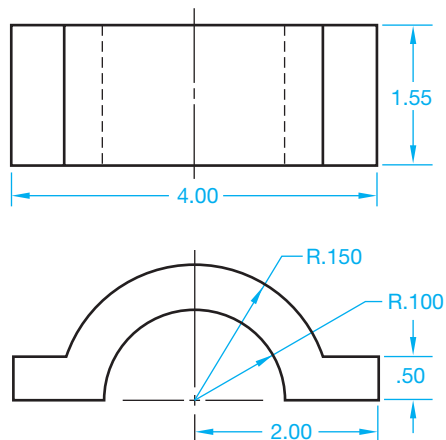
© Cengage Learning 2012

PROBLEM 14.5 Axonometric projection (in.)



© Cengage Learning 2012

PROBLEM 14.13 Oblique projection (in.)



© Cengage Learning 2012

Part 2: Problems 14.6 Through 14.10



To access the Chapter 14 problems, go to the Student CD, select **Chapter Tests and Problems** and **Chapter 14**, and then open the problem of your choice or as assigned by your instructor. Solve the problems using the instructions provided on the CD, unless otherwise specified by your instructor.

**Part 4: Problems 14.14 Through 14.17**



To access the Chapter 14 problems, go to the Student CD, select **Chapter Tests and Problems** and **Chapter 14**, and then open the problem of your choice or as assigned by your instructor. Solve the problems using the instructions provided on the CD, unless otherwise specified by your instructor.

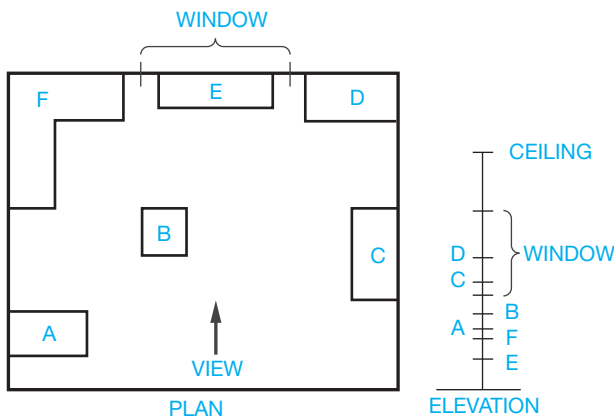
**Part 6: Problems 14.20 Through 14.25**



To access the Chapter 14 problems, go to the Student CD, select **Chapter Tests and Problems** and **Chapter 14**, and then open the problem of your choice or as assigned by your instructor. Solve the problems using the instructions provided on the CD, unless otherwise specified by your instructor.

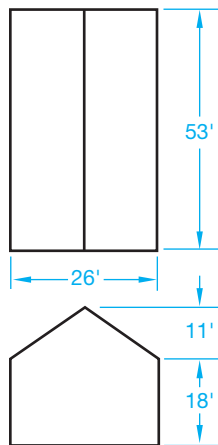
**Part 5: Problems 14.18 and 14.19**

**PROBLEM 14.18 Perspective**



© Cengage Learning 2012

**PROBLEM 14.19 Perspective**



© Cengage Learning 2012

**Part 7: Problems 14.26 and 14.27**

**ADVANCED PROBLEM 14.26**

Go to the Chapter 15, *Working Drawings*, problems located on pages 630 through 677. These problems are presented as assembly drawings, exploded isometric assembly drawings, parts lists, and dimensioned isometric detail drawings. An assembly drawing is a drawing that shows how the parts of a product go together. A detail drawing is a drawing of an individual part that contains all of the views, dimensions, and specifications necessary to manufacture the part. A parts list identifies every part in the assembly and is a tabulation of all parts and materials used in a product. These drawing types are described in detail in Chapter 15, *Working Drawings*. These fundamentals are not important at this time.

From the problems in Chapter 15, select one or more of the problems or as assigned by your instructor. Using the drawings and information provided in the assigned or selected problem, create an exploded isometric technical illustration, with trails, and identification numbers correlated to a parts list. Dimensions are not required. There is no recommended solution, and these problems are considered advanced. In addition or alternately, use your 3-D modeling program to create solid models of the selected parts and assembly. Confirm the preferred approach with your instructor.

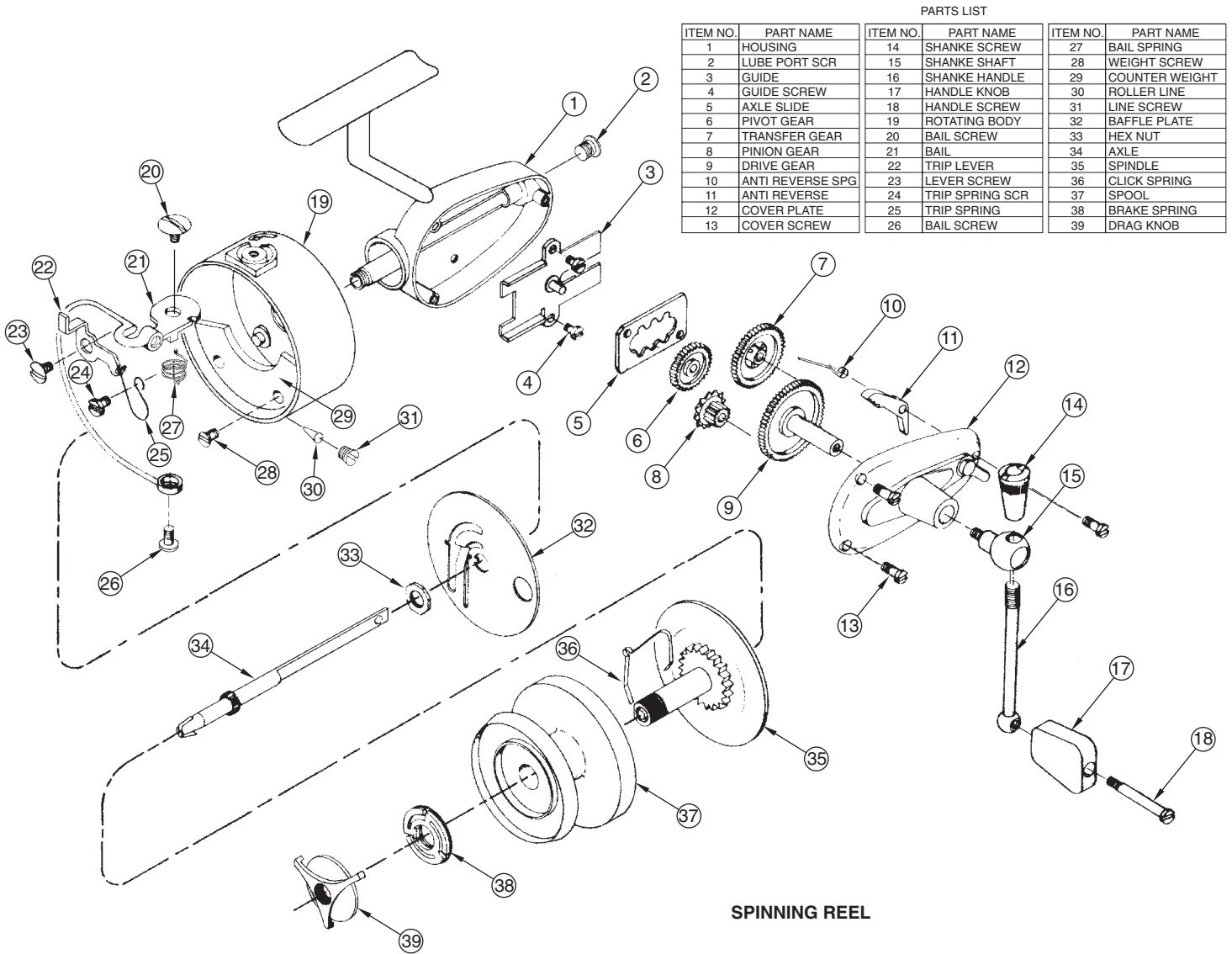
**ADVANCED PROBLEM 14.27**

Find a product of your choice or as assigned by your instructor. The product should have at least four parts and must be something that you can easily disassemble without destroying. This is entirely your responsibility. Using the selected product, create an exploded isometric technical illustration, with trails, and identification numbers correlated to a parts list. You will need to measure the parts to create the drawings. Measurements should be accurate, but exact measurements are not required, because the drawings will



not be dimensioned. There is no recommended solution, and these problems are considered advanced. In addition or alternately, use your 3-D modeling program to create solid

models of the selected parts and assembly. Confirm the preferred approach with your instructor. The following is an example of an exploded isometric assembly drawing:



SPINNING REEL

© Cengage Learning 2012

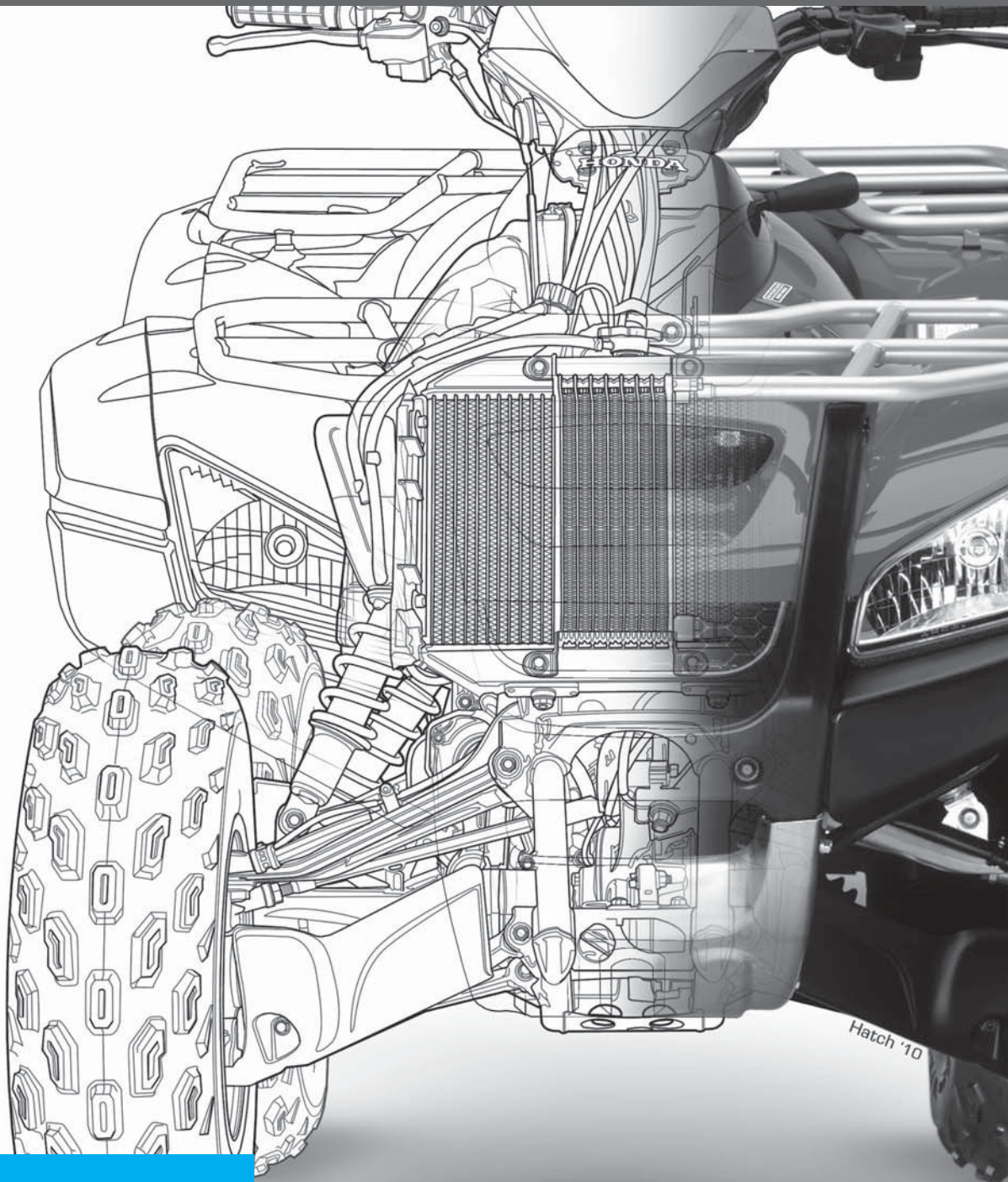
### Math Problems

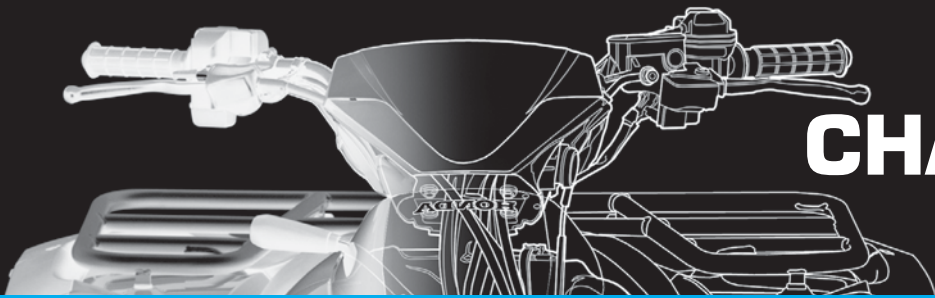
#### Part 8: Problems 14.28 Through 14.32

To access the Chapter 14 problems, go to the Student CD, select **Chapter Tests and Problems** and **Chapter 14**, and then open the math problem of your choice or as assigned

by your instructor. Solve the problems using the instructions provided on the CD, unless otherwise specified by your instructor.

Working Drawings





# CHAPTER 15

## Working Drawings

### LEARNING OBJECTIVES

After completing this chapter, you will:

- Draw complete sets of working drawings, including details, assemblies, and parts lists.
- Prepare written specifications of purchase parts for the parts list.
- Properly group information on the assembly drawing with identification numbering systems.
- Explain the engineering change process and prepare engineering changes.

## THE ENGINEERING DESIGN APPLICATION

The engineering department has been asked to develop a new product line consisting of an adjustment knob replacement kit. As the engineering drafter, you have been supplied with appropriate engineering sketches and asked to develop a complete drawing package.

In the new product development process, several departments within your company need specific information. The manufacturing department needs the dimensional data, material, and finish specifications. Because one of the items in the kit is a purchase part, the purchasing department must be provided with the necessary information to find these parts at the best cost. Packaging information is required to get the product ready for shipping, and the sales department needs some presentation drawings to show to potential clients. In addition, customer assembly drawings are needed for an instruction sheet to be supplied with the kit.

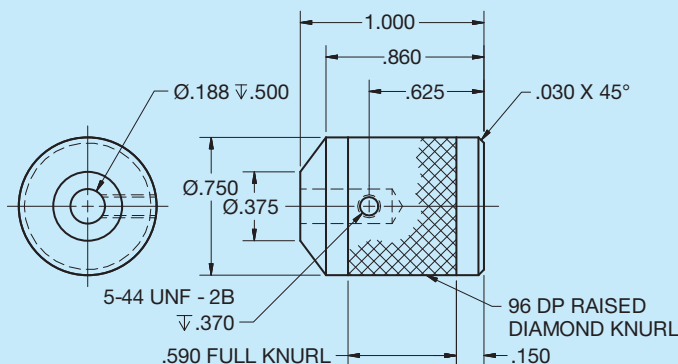
It is up to you to develop a complete set of working drawings. Figures 15.1 through 15.6 show all of the drawings and information used to complete this project.

REVISION HISTORY			
REV	DESCRIPTION	DATE	APPROVED
A	Ø.375 WAS Ø.438	2/9	RJ
B	ADDED KNURL	3/7	RJ

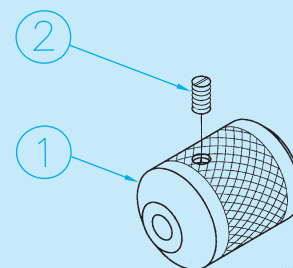
**FIGURE 15.2** Engineering changes must be recorded. Dimension values in this figure are in inches. *Courtesy Engineering Drafting & Design, Inc.*

2	1	RAK-002	5-44UNF SET SCREW	ACME PART NO 15-5-44A
1	1	RAK-001	ADJUSTMENT KNOB	A260
FIND NO	QTY REQD	PART OR IDENT NO	NOMENCLATURE OR DESCRIPTION	NOTES OR REMARKS
PARTS LIST				

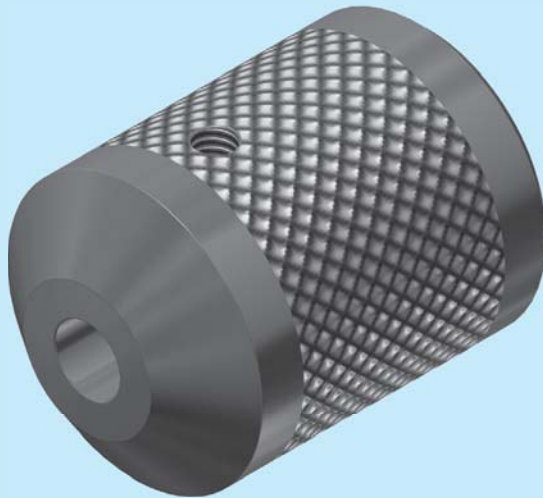
**FIGURE 15.3** Purchasing information is included in the bill of materials or parts list. © Cengage Learning 2012



**FIGURE 15.1** Detail drawings provide the necessary manufacturing information. Dimension values in this figure are in inches. © Cengage Learning 2012

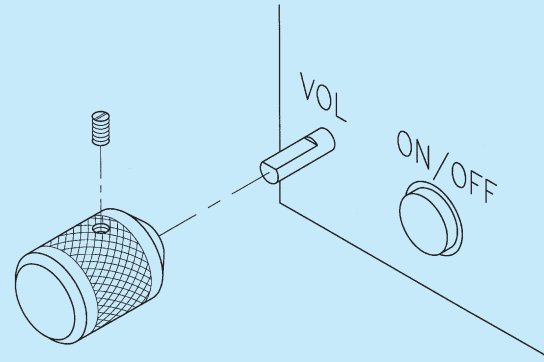


**FIGURE 15.4** Isometric assembly drawings show preassembly data and packaging information. © Cengage Learning 2012



© Cengage Learning 2012

**FIGURE 15.5** Pictorial illustrations can be a valuable for a variety of applications including design, visualization, and sales.



© Cengage Learning 2012

**FIGURE 15.6** Technical illustrations are commonly used to provide customers with instructions on the assembly and use of a product.

## INTRODUCTION TO SECTION FOUR

Everything you have learned up to now has prepared you for the advanced and specialty applications that continue with this section and throughout the rest of this textbook. Section Four is titled *Working Drawings* because this is where you begin to learn how to create a complete set of drawings for a product. You will be able to apply your previous knowledge and skills as you learn more about the design and drafting industry.

Section Four has the following chapters:

Chapter	Title
15	Working Drawings
16	Mechanisms, Linkages, Cams, Gears, and Bearings
17	Belt and Chain Drives
18	Welding Processes and Representations

Creating a set of working drawings is covered first in Chapter 15. A **set of working drawings** includes the detail drawings, assembly drawings, and a parts list for the manufacture and assembly of a product.

The organized of chapters in Section Four is selected so you learn about the principles and options that make up a set of working drawings before you continue with features that can be found in the assembly of products, such as:

- Linkages, cams, gears, and bearings.
- Belt and chain drives.
- Assembly of welded parts.



**NOTE:** Most of the Chapter 15 problems can be drawn without studying the other chapters in this section. However, several of the given problems are

advanced and challenging and are best solved after you study all of Section Four's chapters. If you choose to or are assigned to solve these problems in Chapter 15, then you should study Chapters 16, 17, and 18 as you encounter parts in your problems that relate to those chapters. This is the kind of challenge that you can face in the real world of engineering drafting. Oftentimes, you must go ahead on your own or seek additional instruction when you encounter new and varied obstacles.

## INTRODUCTION TO WORKING DRAWINGS

Most of the drawings that have been shown as examples or assigned as problems in this text are called **detail drawings**. Detail drawings are the kind of drawings that most entry-level mechanical drafters prepare. When a product is designed and drawings are made for manufacturing, each part of the product must have a drawing. These drawings of individual parts are referred to as *detail drawings*. Component parts are assembled to create a final product, and the drawing that shows how the parts go together is called the **assembly drawing**. Associated with the assembly drawing and coordinated to the detail drawings is the **parts list** that identifies all of the parts in the assembly. When the detail drawings, assembly drawing, and parts list are combined, they are referred to as a *complete set* of working drawings. **Working drawings** are a set of drawings that supply all the information necessary to manufacture any given product. A set of working drawings includes all the information and instructions needed for the purchase or manufacture of parts and the assembly of those parts into a product.

## DETAIL DRAWINGS

Detail drawings, which are used by workers in manufacturing, are drawings of each part contained in the assembly of a product. The only parts that do not have to be drawn are standard parts. **Standard parts**, also known as **purchase parts**, are items that can be purchased from an outside supplier more economically than they can be manufactured. Examples of standard or purchased parts are common bolts, screws, pins, keys, and any other product that can be purchased from a vendor. Standard parts do not have to be drawn because a written description clearly identifies the part as shown in Figure 15.7. Detail drawings contain some or all of the following items:

- Necessary multiviews.
- Dimensional information.

### 1/2 - 13UNC-2 X 1.5 LG, SOCKET HEAD CAP SCREW

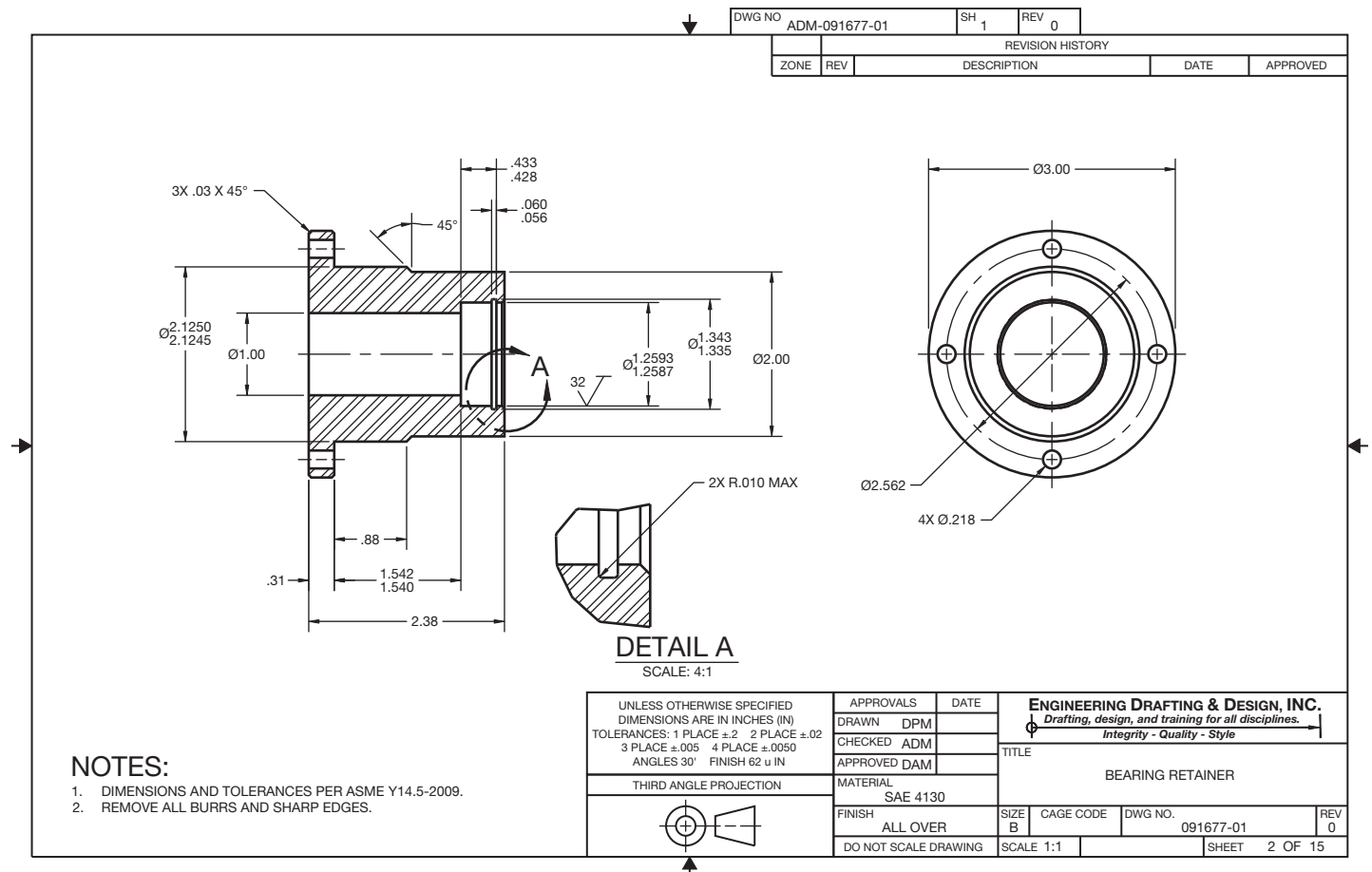
**FIGURE 15.7** Written description of standard or purchase part.  
© Cengage Learning 2012

- Identity of the part, project name, and part number.
- General notes and specific manufacturing information.
- The material of which the part is made.
- The assembly that the part fits (could be keyed to the part number).
- Number of parts required per assembly.
- Name(s) of person(s) who worked on or with the drawing.
- Engineering changes and related information.

In general, detail drawings have information that is classified into three groups:

- Shape description, which shows or describes the shape of the part.
- Size description, which shows the size and location of features on the part.
- Specifications regarding items such as material, finish, and heat treatment.

Figure 15.8 shows an example of a detail drawing.



**FIGURE 15.8** A monodetail drawing has one part per sheet. Dimension values in this figure are in inches. Courtesy Engineering Drafting & Design, Inc.

## Monodetail and Multidetail Drawings

Detail drawings can be prepared with one part per sheet, referred to as a **monodetail** drawing, as in Figure 15.8, or with several parts grouped on one sheet, which is called a **multidetail** drawing. The multidetail drawing is commonly used for tool and fixture design. The method of presentation depends on the choice of the individual company. Most of the drawing-problem assignments in this text are done with one detail drawing per sheet, which is a common industry practice. Some companies, however, draw many details per sheet.

The advantage of monodetail drawings is that each part stands alone, so the drawing of the part can be distributed to manufacturing without several other parts included. The monodetail drawing also allows parts to be used on other assemblies. Drawing sheet sizes can vary, depending on the part size, scale used, and information presented. This procedure requires drawings to be filed with numbers that allow the parts to be located in relation to the assembly. When the monodetail practice is used, there is a group of sheets with parts detailed for one assembly. The sheet numbers correlate the sheets to the assembly, and each part is keyed to the assembly. The sheets are given page numbers identifying the page number and total number of pages in the set. For example, if there are three pages in a set of working drawings, then the first page is identified as 1 of 3, the second as 2 of 3, and the third as 3 of 3.

The advantage of multidetail drawings is that it is more economical to produce drawings with several parts on one sheet. The drafter is able to draw several parts on one sheet, depending on the size of the parts, the scale used, and the information associated with the parts. If there are six parts on one sheet, then the number of sheets used is reduced by five. The company can use one standard sheet size and can encourage drafters to place as many parts as possible on one sheet. Figure 15.9 shows an example of a multidetail drawing with several detail drawings on one sheet. Some companies use both methods at different times, depending on the purpose of the drawings and the type of product. For example, it is more common for the parts of a weldment to be drawn grouped on sheets rather than one part per sheet, because the parts can be fabricated at one location in the shop.



**NOTE:** Multidetail drawing practice is commonly used for one-of-a-kind products with components that are not used on other products. This can also be true in a set of drawings. Most companies have a single detail drawing for each component. This drawing has its own drawing number and is not associated as a sheet-specific sheet in the assembly. This allows the use of the single drawing to be fabricated **in-house** or sent outside for manufacture. Each component can be treated individually. The individual component drawing can reference the assembly on which it is used. *In-house* refers to any operations conducted in a company's own facility instead of being outsourced.

## Sheet Layout

The way in which a detail drawing is laid out normally depends on company practice. Some companies want the drawing to be crowded on as small of a sheet as possible. However, a drawing is easy to read when it is set up on a sheet that provides enough room for views and dimensions without crowding. For example, Figure 15.8 displays two views of a part with dimensions spaced apart far enough to make the drawing clear and easy to read. It is a good idea to provide enough clear space on the drawing to do future revisions without difficulty. An area of the sheet should be kept free to provide for the general notes. This area is often in the lower-left corner, above the title block when using ASME standards, or in the upper-left corner when using military standards. An area should also be left clear of drawing content to provide for engineering change documentation. Preparing engineering changes is covered later in this chapter. The standard location for engineering change information is the upper-right corner of the drawing. It is normally recommended that the space between the revision block and the title block be left clear for future revisions. Some companies place their revision history blocks above or to the left of the title block, although the ASME standard places the revision block in the upper-right corner.

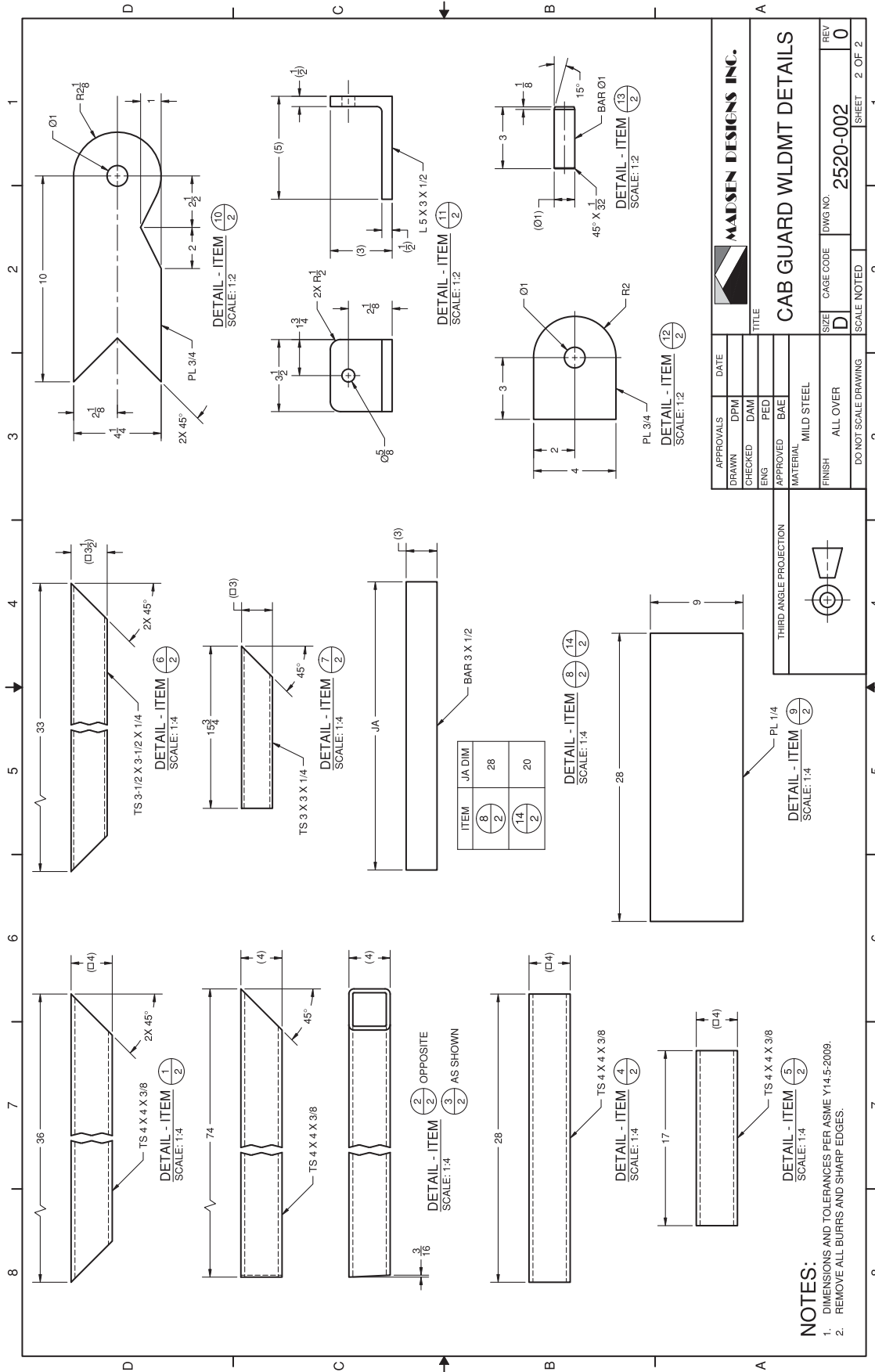
Proper sheet layout planning is important, but the sheet size can be changed quickly and easily at any time if needed to provide additional space when using CADD.

## Steps in Making a Detail Drawing

Review Chapter 8, *Multiviews*, covering the layout of multiviews; Chapter 9, *Auxiliary Views*; and Chapter 10, *Dimensioning and Tolerancing*, which explains in step-by-step detail how to lay out a dimensioned drawing. Review Chapter 11, *Fasteners and Springs*; Chapter 12, *Sections, Revolutions, and Conventional Breaks*; and Chapter 13, *Geometric Dimensioning and Tolerancing*. The information and examples in these chapters set the foundation for everything you do when creating a set of working drawings.

## Detail Drawing Manufacturing Information

Detail drawings are created to suit the needs of the manufacturing processes. A detail drawing has all of the information necessary to manufacture the part. For example, casting and machining information can be together on one drawing. In some situations, a completely dimensioned machining drawing can be sent to the pattern or die maker. The pattern or die is then made to allow for extra material where machined surfaces are specified. When company standards require, two detail drawings are prepared for each part. One detail gives views and dimensions that are necessary only for the casting or forging process. Another detail is created that does not give the previous casting or forging dimensions but provides only the dimensions needed to perform the machining operations on the part. Examples of these drawings are given in Chapter 10, *Dimensioning and Tolerancing*.



**FIGURE 15.9** A multidetail drawing has several detail drawings on one sheet. Dimension values in this figure are in inches. Courtesy Madsen Designs Inc.

## DETAIL DRAWINGS

CADD systems can be used to produce monodetail and multidetail drawings, depending on the purpose or company standard. One approach to preparing monodetail drawings is to create each drawing in a separate drawing file. For example, when using AutoCAD, the process of producing a monodetail drawing involves the following steps:

1. Create a new drawing file based on a drawing template file.
2. Draw dimensioned views at full scale in Model Space.
3. Access a Layout, also known as Paper Space, to display and plot the detail drawing at a specific scale on a selected sheet size, with a border, title block, general notes, and other necessary sheet content.

These steps are repeated until all the detail drawings have been created in individual drawing files. The typical

process of producing a multidetail drawing is similar, except that Model Space contains the dimensioned views of several parts.

An alternative technique for developing monodetail drawings is to create multiple detailed drawings in Model Space, using a single file, as previously described for creating a multidetail drawing. However, instead of using a Layout to display all the detail drawings on a single sheet, use separate Layouts to view each detail drawing. This method is most effective for producing monodetail drawings of small, standard parts, providing a single drawing file that can be used as a parts library or when company standards require the development of a multidetail drawing and individual monodetail drawings of the same parts. Multidetail drawings can also be drawn by referencing content from multiple files. For example, the AutoCAD External Reference, or XREF, command can be used to insert monodetail drawings from several files into a single drawing without significantly increasing file size.

## DETAIL DRAWINGS

As with traditional 2-D drafting software, 3-D CADD programs that combine 2-D drawing capabilities allow you to create monodetail or multidetail drawings. However, the process of producing detail drawings is significantly different, because the drawing geometry and dimensions usually associate with existing model files. Developing a monodetail drawing based on a 3-D model typically involves the following steps.

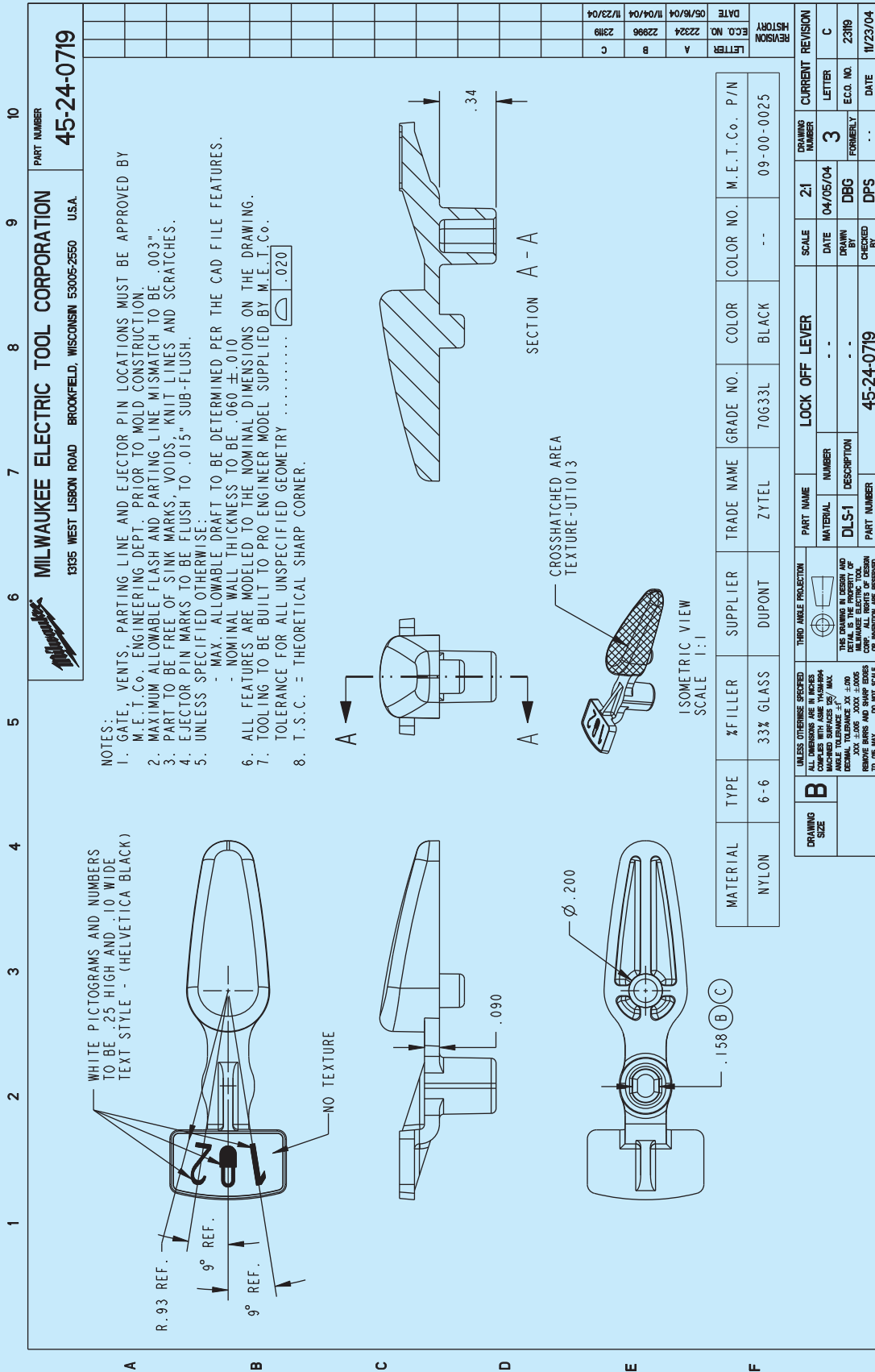
1. Create a new drawing file based on a drawing file template. The drawing file usually contains or allows you to specify a sheet that represents a specific paper size, and it contains a border, title block, general notes, and other necessary sheet content.

2. Place and scale drawing views associated with a single part model.
3. Add dimensions and other specifications as needed.

Then you can add monodetail drawings in the same drawing file by inserting additional sheets. Follow the same steps to create a multidetail drawing, but place several detail drawings on the same sheet by referencing multiple part models. Figure 15.10 shows a 2-D detail drawing created by referencing a 3-D solid model. This detail drawing is one of numerous detail drawings in a set of working drawings.

(Continued)





**FIGURE 15.10** An example of a 2-D monodetail drawing extracted from a 3-D solid model. Courtesy Milwaukee Electric Tool Corporation

## ASSEMBLY DRAWINGS

Most products are composed of several parts. A drawing showing how all of the parts fit together is called an assembly drawing. Assembly drawings differ in the amount of information provided, and this decision often depends on the nature or complexity of the product. Assembly drawings are generally multiview drawings. Your goal in the preparation of assembly drawings is to use as few views as possible to completely describe how each part goes together. In many cases, a single front view is the only view necessary to describe the assembly (see Figure 15.11). Full sections are commonly associated with assembly drawings, because a full section exposes the assembly of most or all of the internal features as shown in Figure 15.12, page 603. If one section or view is not enough to show how the parts fit together, then a number of views or sections can be necessary. In some situations, a front view or group of views with broken-out sections is the best method of showing the external features while exposing some of the internal features (see Figure 15.13, page 604). You must make the assembly drawing clear enough for the assembly department to put the product together. Other elements of assembly drawings that make them different from detail drawings are that they usually contain few or no hidden lines or dimensions. Hidden lines should be avoided on assembly drawings unless necessary for clarity. The common practice is to draw an exterior view to clarify outside features and a sectional view to expose interior features.

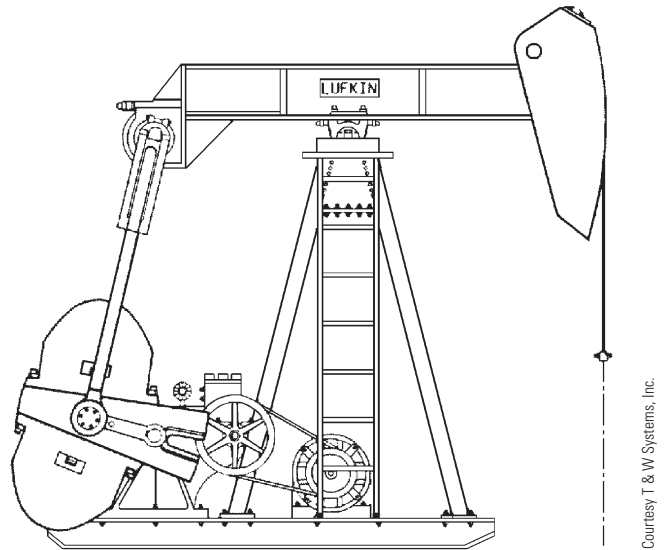


FIGURE 15.11 Assembly drawing with single front view.

Dimensions serve no purpose on an assembly drawing unless the dimensions are used to show the assembly relationship of one part to another. **Assembly dimensions** are only necessary when a certain distance between parts must exist before proper assembly can take place. Machining processes and other specifications are generally not given on an assembly drawing unless a machining operation must take

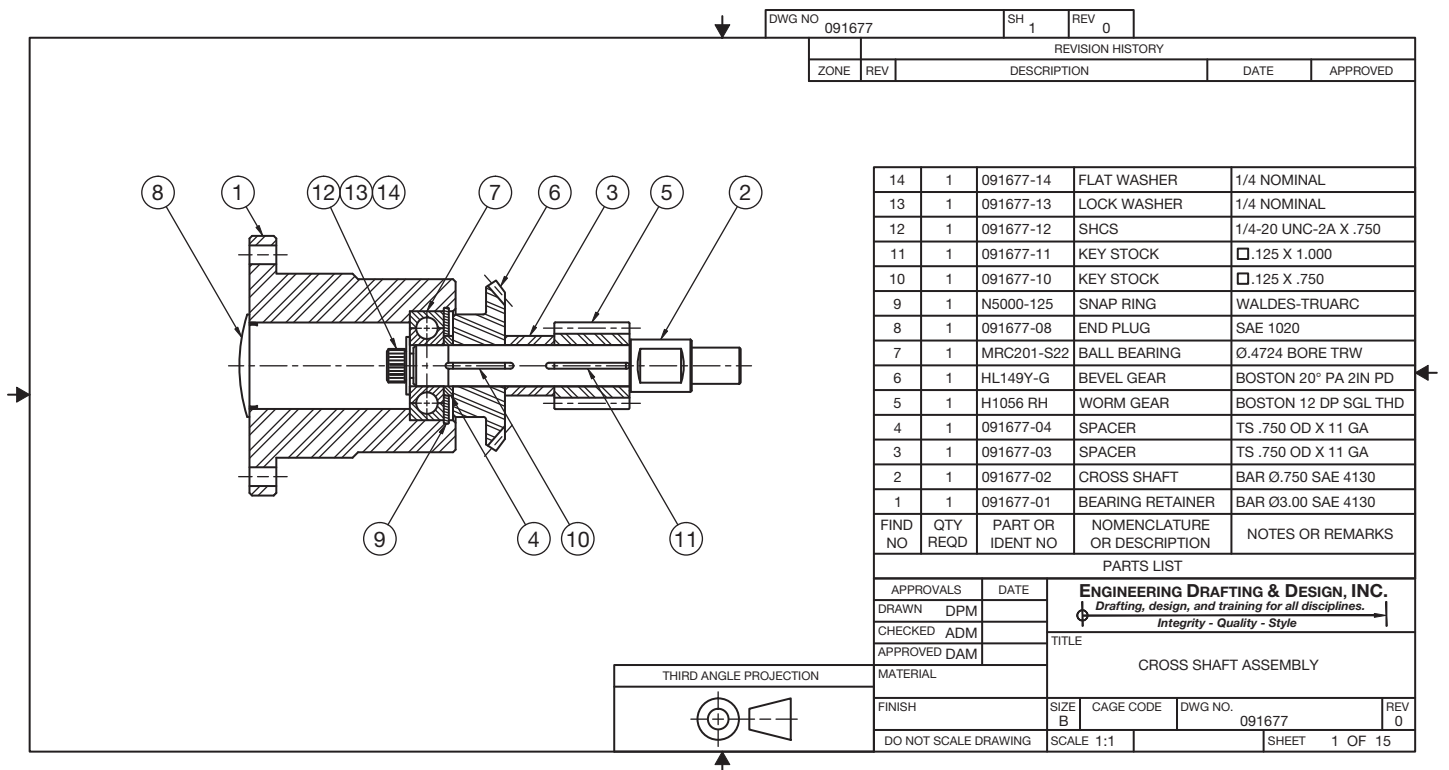


FIGURE 15.12 Assembly in full section. Courtesy Engineering Drafting & Design, Inc.

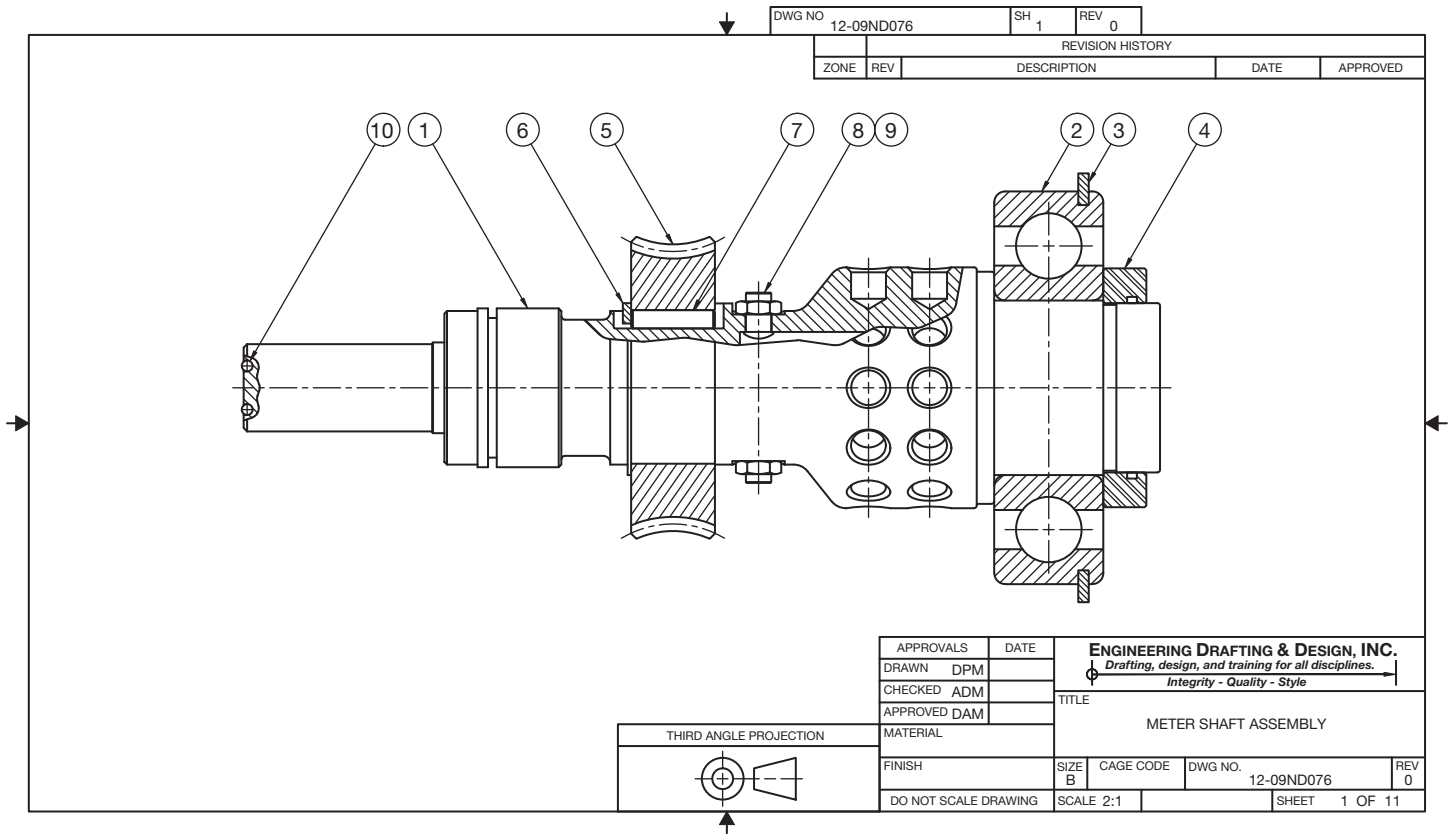


FIGURE 15.13 Assembly with broken-out sections. Courtesy Engineering Drafting & Design, Inc.

place after two or more parts are assembled. Other assembly notes can include bolt tightening specifications, assembly welds, and cleaning, painting, or decal placement that must take place after assembly. Figure 15.14 shows a process note applied to an assembly drawing. Some company standards or drafting presentations prefer that assemblies be drawn with sectioned parts shown without section lines, although this is not a common practice. Sectioned assemblies do not show section lines on objects such as fasteners, pins, keys, and shafts when the cutting plan passes through these objects and is parallel to their axes. Figure 15.15 shows a full section assembly with parts left unsectioned.

Assembly drawings can contain some or all of the following information:

- One or more views. Auxiliary views are used as needed.
- Sections necessary to show internal features, function, and assembly.
- Enlarged views necessary to show adequate detail.
- Arrangement of parts.
- Overall size and specific dimensions necessary for assembly.
- Manufacturing processes necessary for, during, or after assembly.
- Reference or item numbers that key the assembly to a parts list and to the details.
- Parts list or bill of materials.

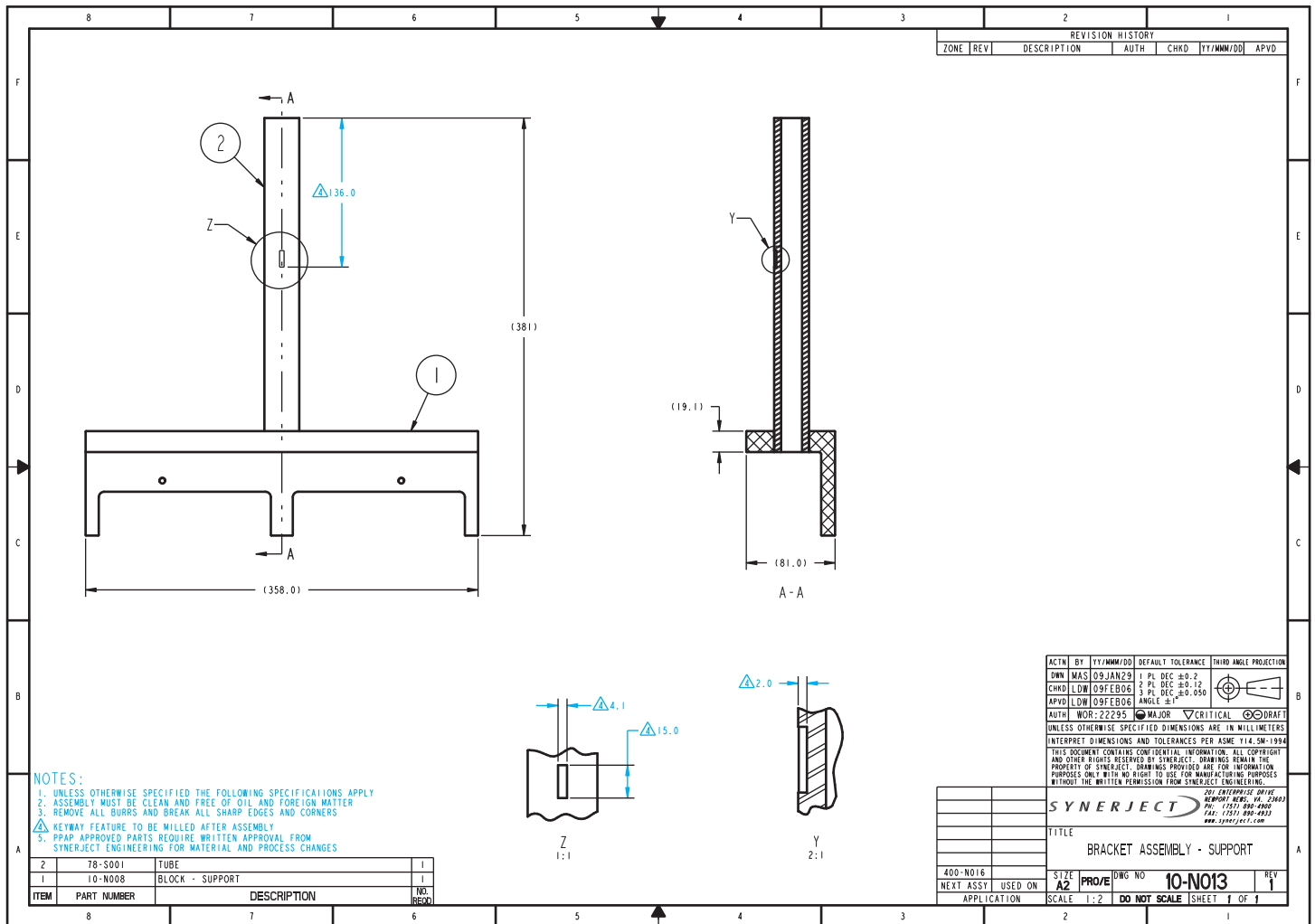
## TYPES OF ASSEMBLY DRAWINGS

There are several different types of assembly drawings used in industry, including:

- Layout, or design, assembly.
- General assembly.
- Working-drawing or detail assembly.
- Erection assembly.
- Subassembly.
- Pictorial assembly.

### Layout Assembly

Engineers and designers can prepare a design layout in the form of a sketch or as an informal drawing. These engineering design drawings are used to establish the relationship of parts in a product assembly. From the layout, the engineer prepares sketches or informal detail drawings for prototype construction. This **research and development (R&D)** is the first step in the process of taking a design from an idea to a manufactured product. Layout, or design, assemblies can take any form, depending on the drafting ability of the engineer, the period for product implementation, the complexity of the product, or company procedures. In many companies, the engineers work with drafters who help prepare formal drawings from engineering sketches or informal drawings. The R&D department is one



**FIGURE 15.14** A process note on an assembly drawing. Dimension values in this figure are in millimeters. The triangle with the number 4 inside is called a delta note or flag note and is used to refer the reader to note number 4 in the general notes. *Courtesy Synerject North America, Newport News, Virginia*

of the most exciting places for a drafter to work, because this is where new ideas are developed. Figure 15.16 shows a basic layout assembly of a product in the development stage. The limits of operation are shown using phantom lines.

## General Assembly

**General assemblies** are the most common types of assemblies that are used in a complete set of working drawings. A set of working drawings contains three parts: detail drawings, an assembly drawing, and a parts list. The general assembly contains the features previously discussed in this chapter, including multiviews, auxiliary views, detail views, and sectional views as needed for the specific product. Each part is identified with a **balloon** containing a number keyed to the parts list. A balloon is a circle placed on the drawing with a part identification number inside the circle. Each balloon is connected to its related part with a leader line. The balloon part

identification number correlates to the same number identifying the part in the parts list. The parts list identifies every part in the assembly. Balloons are described in more detail later in this chapter. A typical general assembly is shown in Figure 15.14 and in Figure 15.24, page 611. The additional features found on a general assembly are discussed throughout the rest of this chapter.

## Detail Assembly

A **detail assembly** shows the details of parts combined on the same sheet with an assembly of the parts. This practice is also referred to as a **working-drawing assembly**. Although this application is not as common as a general assembly, it is a practice used at some companies. The use of working-drawing assemblies can be a company standard, or this technique can be used in a specific situation even when it is not considered a normal procedure at a particular company.

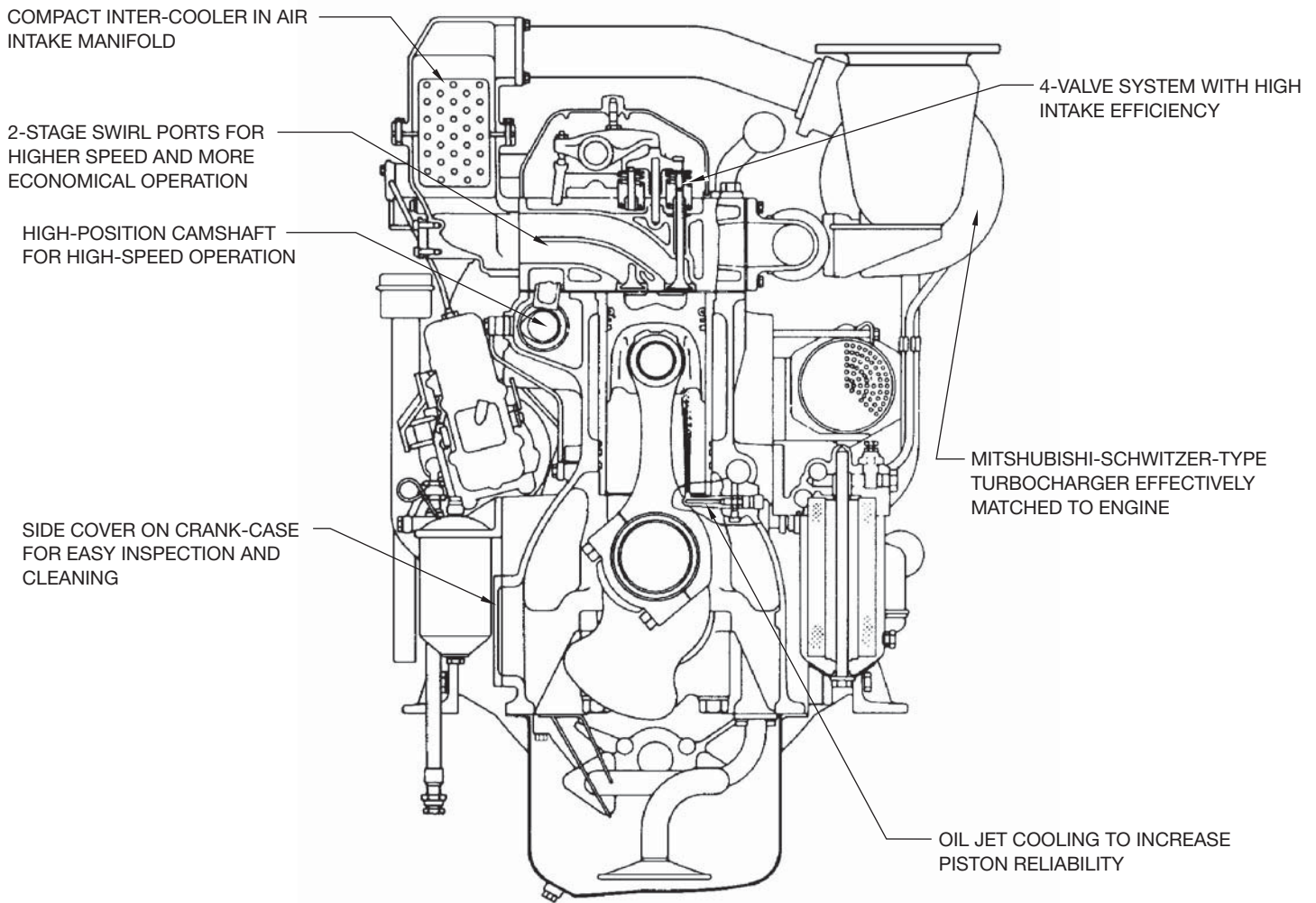


FIGURE 15.15 Full section assembly with section lines omitted. Courtesy Mitsubishi Heavy Industries, Ltd.

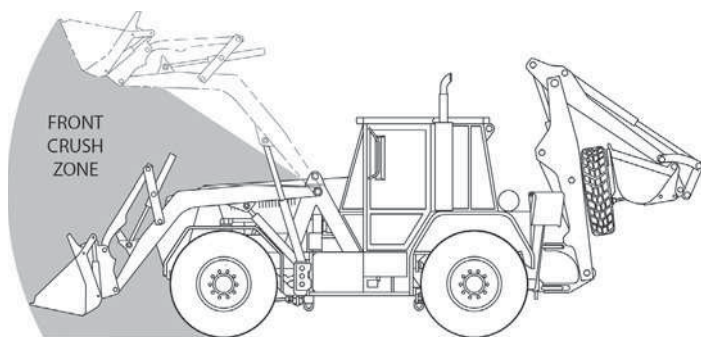


FIGURE 15.16 Layout assembly. The limits of operation are shown with phantom lines and with a shaded area. Courtesy O'Neil & Associates, Inc.

The detail assembly can be used when the end result requires the details and assembly be combined on as few sheets as possible. An example can be a product with few parts that is produced only once for a specific purpose (see Figure 15.17). Another example of a detail assembly

is a product shown with its component parts assembled in a manufacturer's catalog or on its Web site as shown in Figure 15.18.

## Erection Assembly

**Erection assemblies** usually differ from general assemblies in that dimensions and fabrication specifications are commonly included. Erection assemblies are used for fabrication and assembly, and they are typically associated with products that are made of structural steel or with cabinetry. Figure 15.19 shows an erection assembly with multiviews, fabrication dimensions, and an isometric drawing that helps display how the parts fit together.

## Subassembly

The complete assembly of a product can be made up of several separate component assemblies. These individual unit assemblies are called **subassemblies**. A complete set of working drawings can have several subassemblies, each with its own detail drawings.

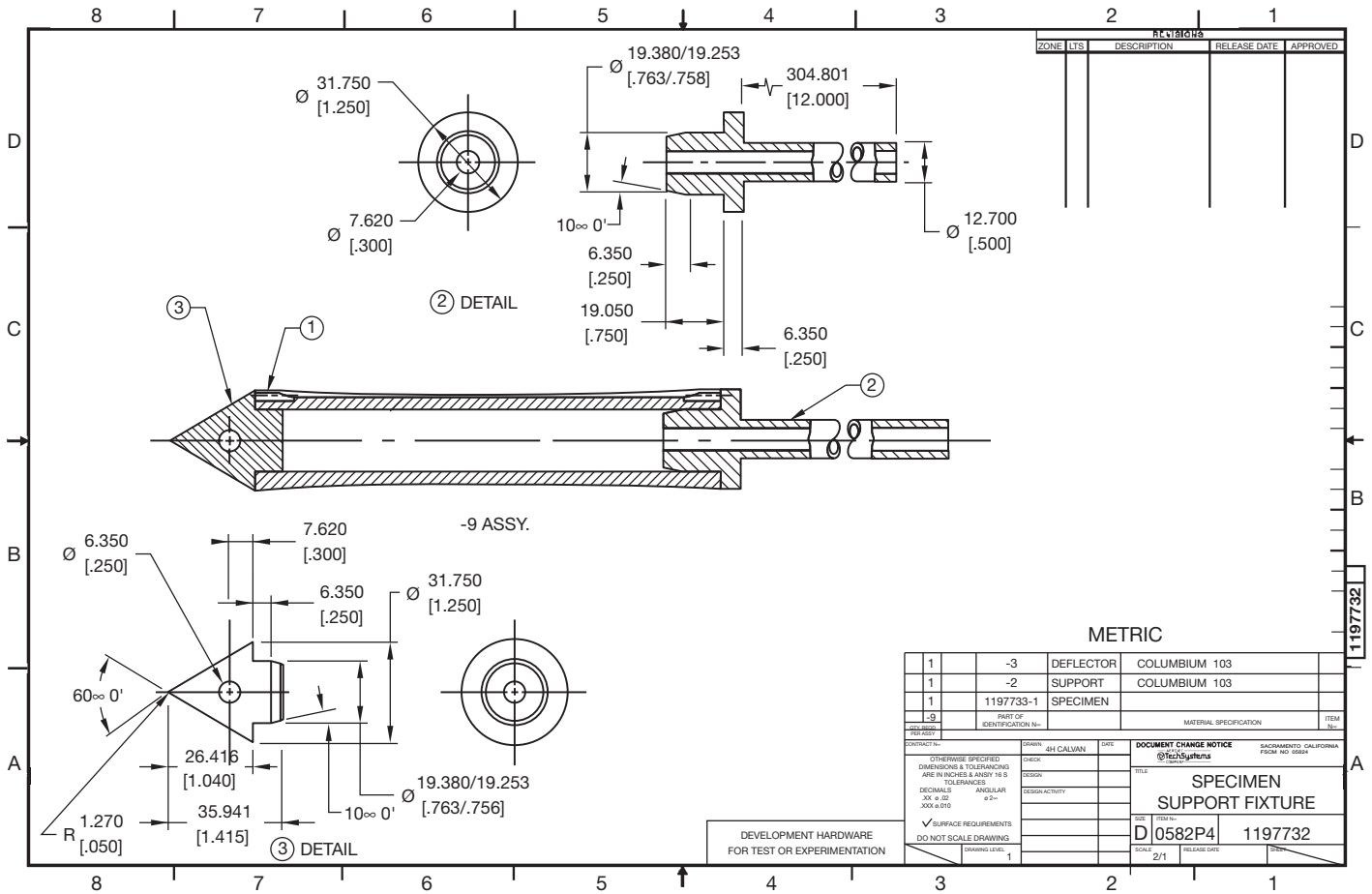


FIGURE 15.17 Working-drawing, or detail, assembly. Courtesy Aerojet Propulsion Division

The subassemblies are put together to form the general assembly. The general assembly of an automobile, for example, includes the subassemblies of the drive components, the engine components, and the steering column, just to name a few. An assembly, such as an engine, can have other subassemblies, such as carburetor and generator. Figure 15.20, page 609, shows a subassembly with a parts list identifying the parts in the subassembly.

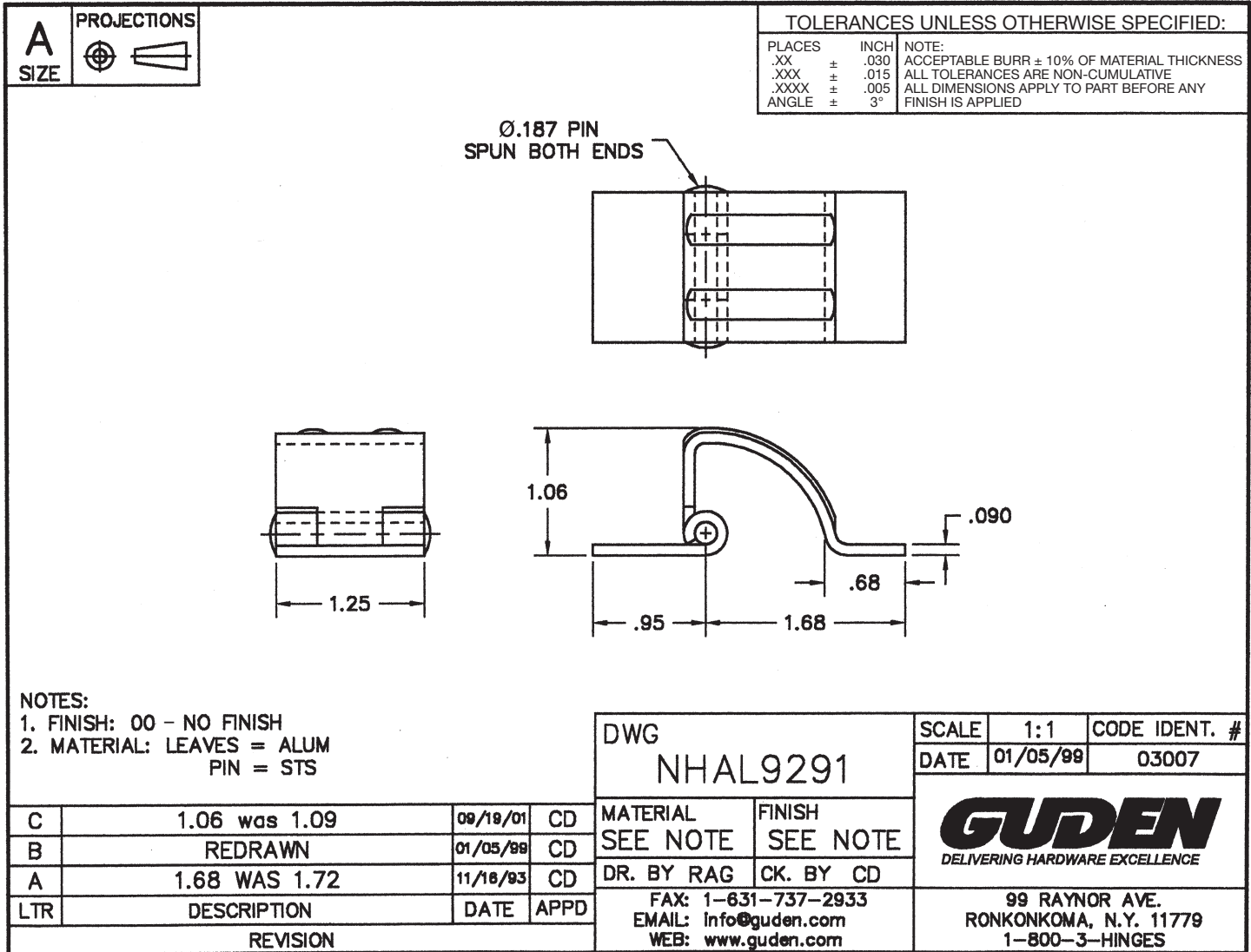
## Pictorial Assembly

**Pictorial assemblies** are used to display a pictorial rather than multiview representation of the product, which can be used in other types of assembly drawings. Pictorial assemblies can be made from photographs, artistic renderings, or CADD models. The pictorial assembly can be as simple as the isometric drawing in Figure 15.19, which is used to assist workers in the assembly of the product. Pictorial assemblies are commonly used in product catalogs or brochures. These pictorial representations can be used for sales promotion, customer self-assembly, or maintenance procedures (see Figure 15.21). Pictorial assemblies can also take the form of **exploded technical illustrations**, also commonly known as **illustrated parts breakdowns**. These exploded technical illustrations are used in vendors' catalogs

and instruction manuals and for maintenance or assembly. The exploded technical illustration displays the parts of an assembly placed apart that shows how the parts fit together; each part is identified with a balloon correlated to a parts list (see Figure 15.22). Exploded technical illustrations are described in detail in Chapter 14, *Pictorial Drawings and Technical Illustrations*.

## IDENTIFICATION NUMBERS

**Identification** or **item numbers** are used to key the parts from the assembly drawing to the parts list. Identification numbers are generally placed in balloons. Balloons are circles that are connected to the related part with a leader line. Several of the assembly drawings in this chapter show examples of identification numbers and balloons. Numbers in balloons are common, although some companies prefer to use identification letters. Balloons are drawn between .375 and 1 in. (10–25 mm) in diameter, depending on the size of the drawing and the amount of information that must be placed in the balloon. All balloons on the drawing are the same size. The leaders connecting the balloons to the parts are thin lines that can be presented in any one of several formats, depending on company standards. Figure 15.23 shows the common methods used to connect balloon



**FIGURE 15.18** This product is an example of a detail assembly with its component parts assembled in a manufacturer's catalog or on a Web site. Dimension values in this figure are in inches. Courtesy H.A. Guden Co., Inc.

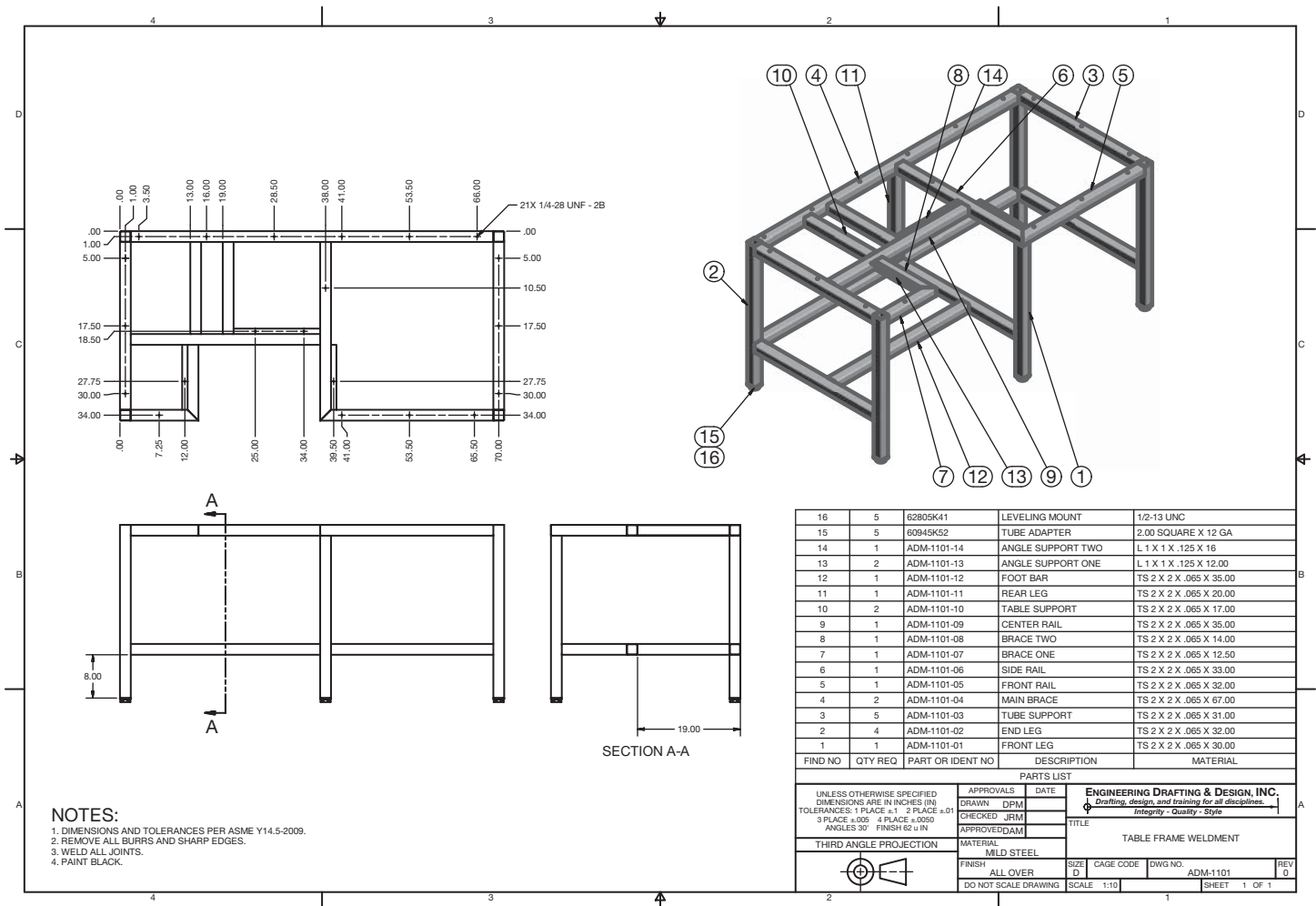
leaders. Notice that the leaders can terminate with arrowheads or dots. Whichever method of connecting balloons is used, the same technique should be used throughout the entire drawing. An exception is the common practice of using leader arrowheads when pointing to the profile of a part and using a leader with a dot when pointing to the surface of a part.

The item numbers in balloons should be grouped so they are in an easy-to-read pattern. This is referred to as **information grouping**. Good information grouping occurs when balloons are aligned in a pattern that is easy to follow rather than scattered about the drawing (see Figure 15.24). In some situations, when particular part groups are so closely related that individual identification is difficult, the identification balloons can be grouped next to each other. For example, a cap screw, lock washer, and flat washer can require that the balloons be placed in a cluster or side by side, as shown with items 12, 13, and 14 in Figure 15.12 on page 603.

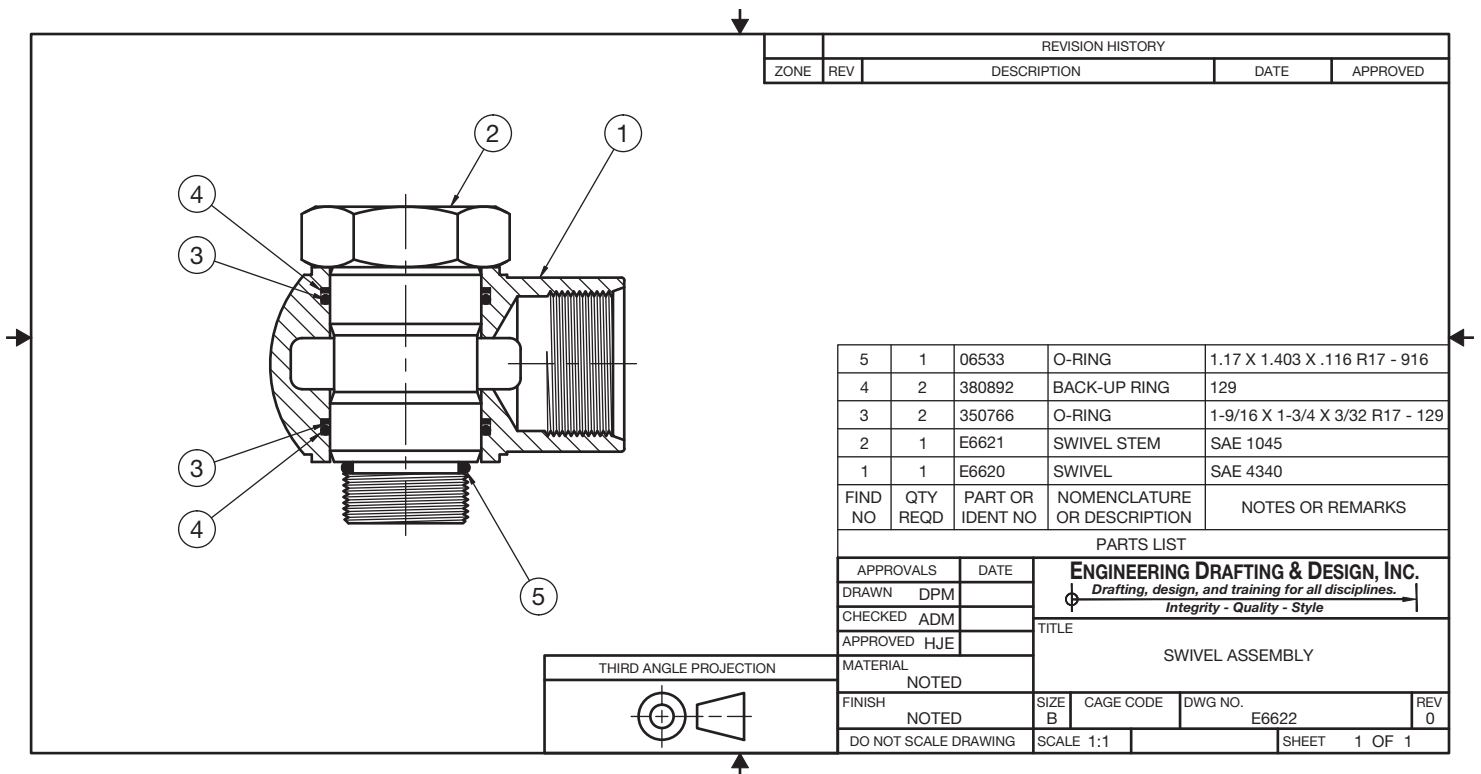
The balloons key the detail drawings to the assembly and parts list, and they can also key the assembly drawing and parts list to the page on which the detail drawing is found. The format for this type of a balloon identification system is shown in Figure 15.25. Figure 15.26 is an assembly drawing and parts list located on page 1 of a two-page set of working drawings. Notice how the balloons in Figure 15.26 key the parts from the assembly and parts list to the detail drawings found on page 2. The page 2 details are located in Figure 15.9 (see page 600). Each sheet is also numbered, with sheet 1 numbered 1 OF 1, and sheet 2 numbered 2 OF 2.

## PARTS LISTS

The parts list, also known as a **bill of materials** or **list of materials**, is usually combined with the assembly drawing, but it remains one of the individual components of a complete set

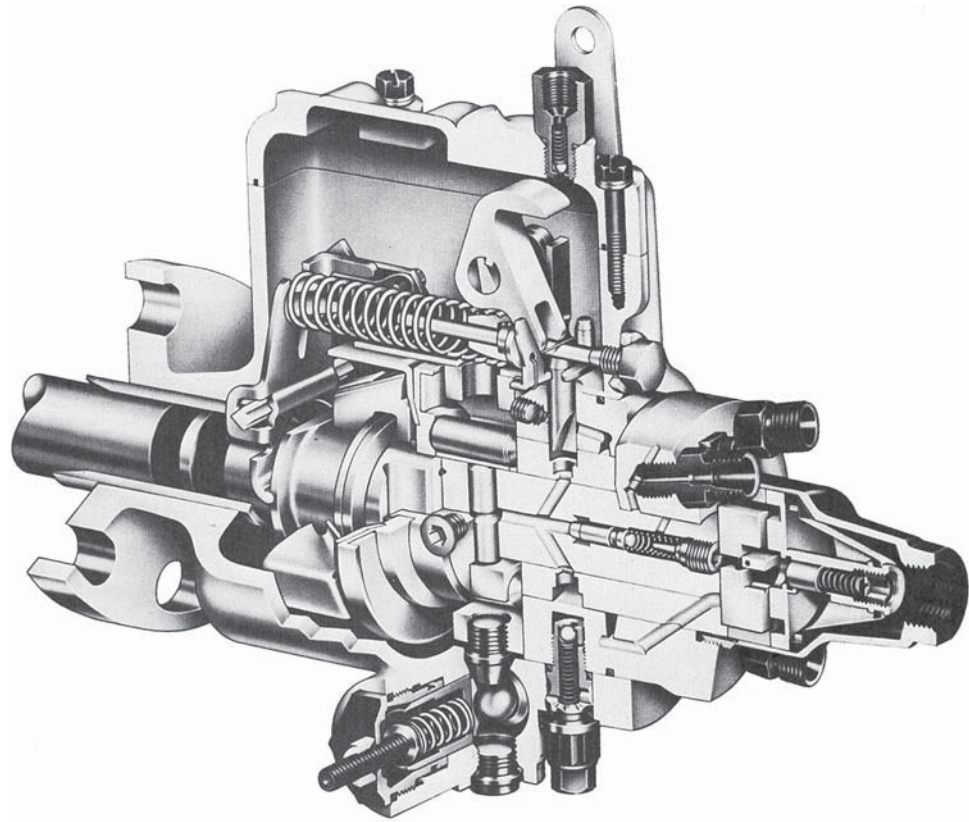


**FIGURE 15.19** Erection assembly. Dimension values in this figure are in inches. *Courtesy Engineering Drafting & Design, Inc.*



**FIGURE 15.20** Subassembly with parts list. *Courtesy Engineering Drafting & Design, Inc.*





Courtesy Stanadyne Diesel Systems

FIGURE 15.21 Pictorial assembly.

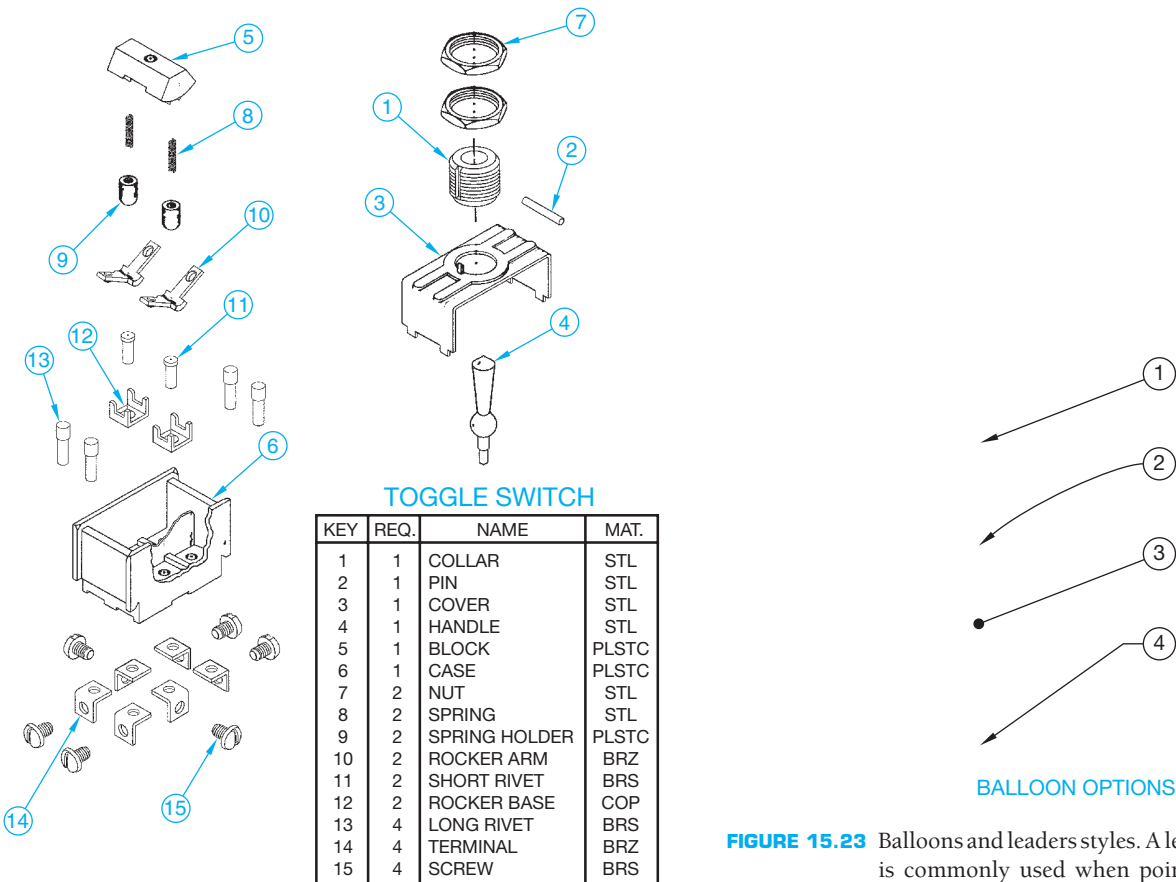


FIGURE 15.22 Exploded isometric assembly. © Cengage Learning 2012

FIGURE 15.23 Balloons and leaders styles. A leader line with arrowhead is commonly used when pointing to the outline of a part, and the leader line with dot is used when pointing to the surface of a part. © Cengage Learning 2012

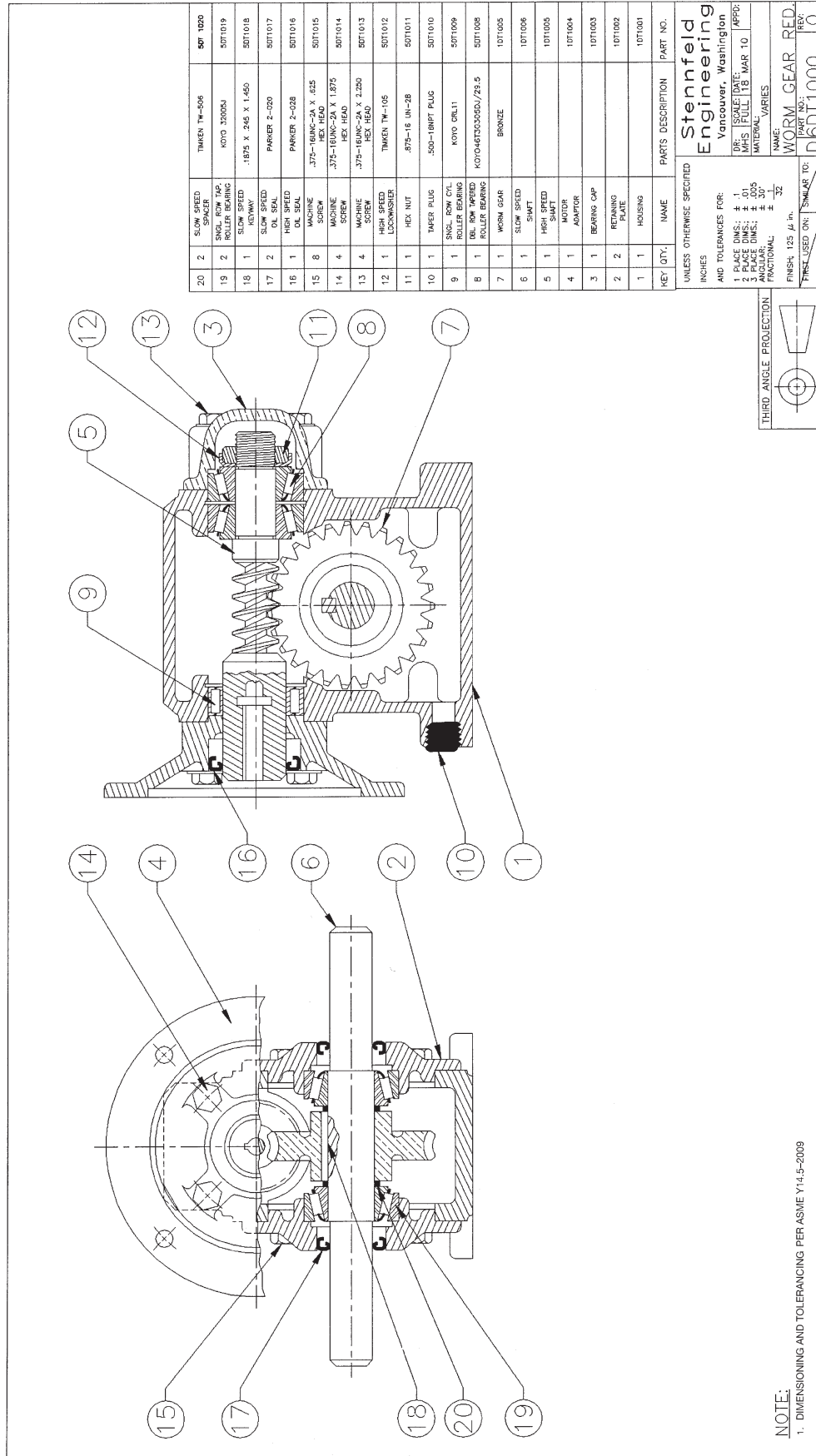
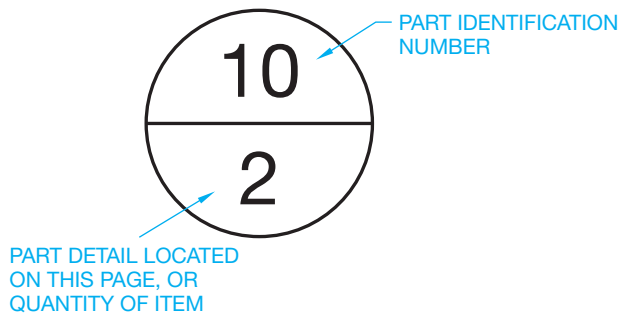


FIGURE 15.24 Assembly drawing and parts list. Notice the balloon alignment for quality information grouping. © Cengage Learning 2012



© Cengage Learning 2012

FIGURE 15.25 Balloon with page identification.

of working drawings. The information associated with the parts list generally includes:

- Item number—from balloons. Item number is also called *find number*.
- Quantity—the number of that particular part used on this assembly.
- Part or drawing number, which is a reference back to the detail drawing.
- Description, which is usually a part name or complete description of a purchase part or stock specification, including sizes or dimensions.
- Material identification—the material used to make the part.
- Information about vendors for purchase parts.
- Sheet number.

Parts lists can contain some or all of the previous information, depending on company standards. The first four elements listed are the most common items. When all six elements are provided, the parts list can also be called a *list of materials* or a *bill of materials*.

When placed on the assembly drawing, the parts list can be located above or to the left of the title block, in the upper-right or upper-left corner of the sheet, or in a convenient location on the drawing field. The location depends on company standards, although the position above or to the left of the title block is most common. The information on the parts list is usually presented with the first item number followed by consecutive item numbers. When the parts list is so extensive that the columns fill the page, a new group of columns is added next to the first. If additional parts are added to the assembly, then space on the parts list is available. This is the reason that parts list data is provided from the bottom of the sheet upward or the top of the sheet downward.

Most companies prepare parts lists in the CADD program or other database software so information can be retrieved and edited easily. The parts list content is usually in a table format when using a CADD or other electronic system, and the information inside the parts list can be easily edited for changes. When the set of working drawings is prepared on a CADD system, the parts list can be parametrically associated with the details and assembly, so changes to any are automatically updated on all.

The parts list is not always placed on the assembly drawing. Some companies prefer to prepare parts lists on separate sheets, which allows for convenient filing. This method also allows the

parts list to be computer generated separately from the drawings. Separate parts lists are usually prepared on a computer so information can be edited conveniently (see Figure 15.27).



**NOTE:** An engineering change request (ECR) can require the removal of a component from the parts list. When this happens, the balloons and parts list numbers are not usually renumbered, because other documents may reference the balloon and part list numbers. Instead, the word REMOVED is placed in the parts list next to the balloon number that has been deleted. Not all companies use this practice. Instead, they renumber the balloons and parts list and correlate all other related documents.

## STANDARDS

**ASME ASME Y14.34-2008, *Associated Lists***, is the standard that establishes the minimum requirements for the preparation and revision of application lists, data lists, index lists, parts lists, and wire lists. This standard defines the following terms related to lists found on engineering drawings and related documents.

**Application list (AL)** is the number, the system of words used to name things in a discipline, description, the list of names, features or terms, and part and assembly designation data presented in a separate list.

**Data list (DL)** is a tabulation of all engineering drawings, associated lists, specifications, standards, and subdata lists related to the item for which the data list applies.

**Item** is a term used to identify any material, part, unit or product.

**Item number** or **find number** is the reference number assigned to an item on the field of the drawing and correlated to the part or identification number in the parts list.

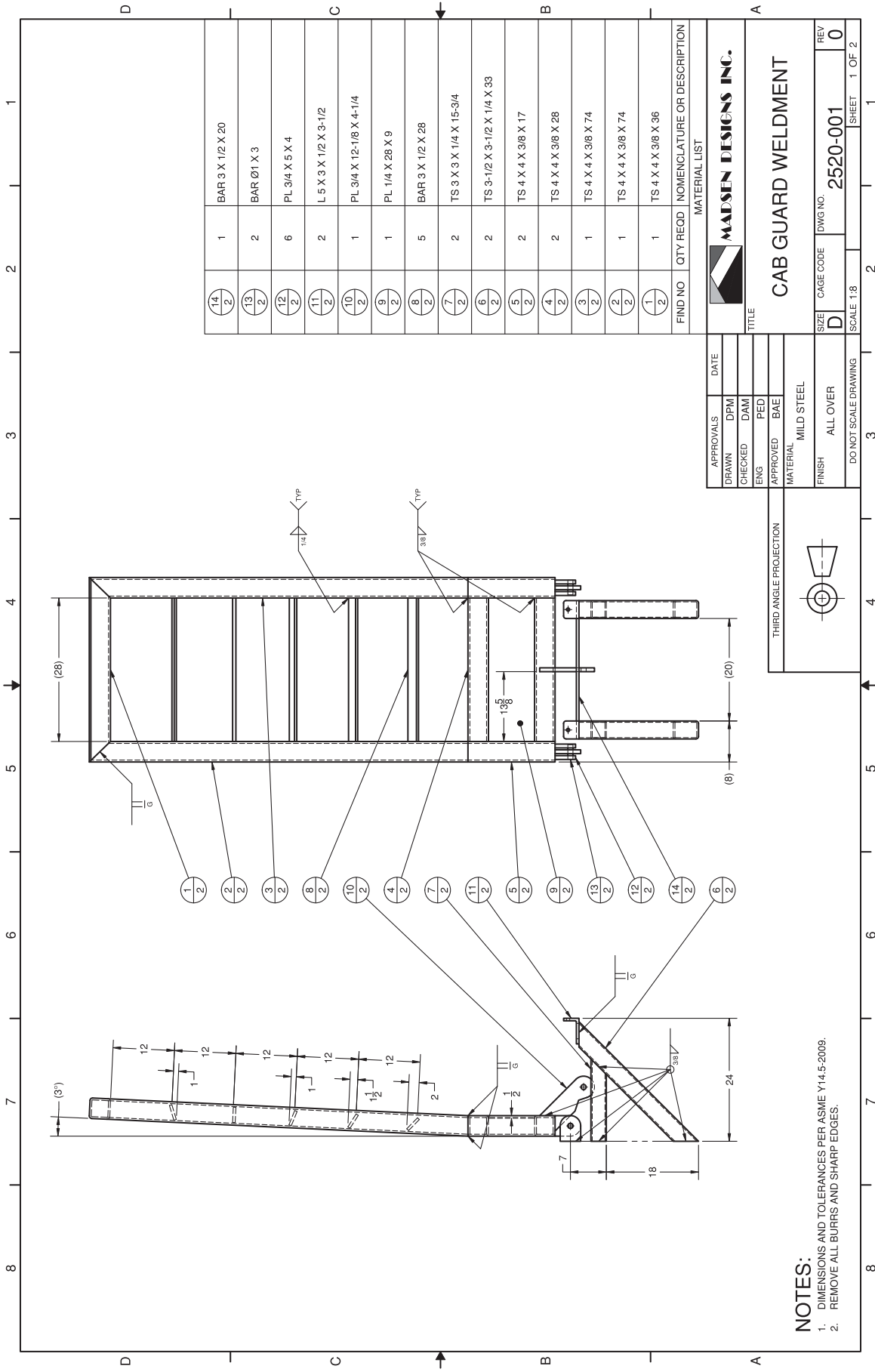
**Parts list (PL)** is a tabulation of all parts and materials used in a product.

**Tabular** refers to anything, such as a list arranged in table form. Tabular lists can be parametrically associated to the documents from which they are created. For example, an item on the drawing can be associated to the list and any change made to one automatically affects the other.

**Wire list (WL)** is a list of tabular data and instructions used to establish wiring connections.

## PURCHASE PARTS

Purchase parts, also referred to as *standard parts*, are parts that are manufactured and available for purchase from a supplier. Purchase parts are items such as fasteners, pins, keys, washers, and other common products. It is generally more economical for a company to buy these items than to make them. Parts that are available from



**FIGURE 15.26** Assembly and parts list with page identification balloons. Dimension values in this figure are in inches. Courtesy Madsen Designs Inc.

ENGINEERING DRAFTING & DESIGN, INC. Drafting, design, and training for all disciplines. Integrity - Quality - Style							
ASSEMBLY: <b>CRYOGENIC VALVE</b>				ASSEMBLY NUMBER: <b>MSIV12-09-0087</b>			
NUMBER OF UNITS: <b>250</b>				MANAGEMENT: _____ DATE: _____			
PARTS LIST							
HAVE	NEED	FIND NO	QTY REQD	DIA	PART OR IDENT NO	NOMENCLATURE OR DESCRIPTION	NOTES OR REMARKS
✓		①	1		087930-01	HOUSING	
✓		②	1		087930-02	HOUSING COVER	
	✓	③	4		224707-10	3/4 X 1/4-20UNC HEX BOLT	
	✓	④	4		224707-20	3/4 FLAT WASHER	
	✓	⑤	4		224707-33	3/4 X 1/4-20UNC HEX NUT	
✓		⑥	2		224707-34	SHAFT ADAPTER	

Courtesy Engineering Drafting &amp; Design, Inc.

FIGURE 15.27 Parts list separate from assembly drawing.

suppliers can be found in the *Machinery's Handbook*, *Fastener's Handbook*, or vendors' catalogs. Purchase parts do not require a detail drawing, because a written description completely describes the part. For this reason, the purchase parts found in an assembly must be described clearly and completely in the parts list. Some companies have a purchase parts computer database or directory that is used to record all purchase parts used in their product line. The standard parts database gives a reference number for each part, which is placed on the parts list for convenient identification.

## ENGINEERING CHANGES

### STANDARDS

**ASME** The standards controlling the use of engineering changes are specified in ASME Y14.35M, *Revision of Engineering Drawings and Associated Documents*. This standard defines the practices for revising drawings and associated documentation, and it establishes methods for identification and recording revisions.

## ASSEMBLY DRAWINGS

One of the major benefits of using CADD is the ability to reuse existing drawing content. This practice significantly reduces the amount of time spent drawing assemblies, and it increases accuracy. The following steps represent a common approach to preparing assembly drawings quickly and easily using AutoCAD, for example.

1. Create detail drawings first. Use a separate layer for visible object lines, which are used to represent each part in the assembly drawing.
2. Create a new drawing file based on an existing drawing file template. You will use this file to generate the assembly.
3. Option 1:
  - Insert the detail drawing files into the assembly drawing file as blocks.
  - Explode the blocks.
  - Erase all items except the principal view of each detail drawing.

Option 2:

- Open each detail drawing and create a block of the principal view.
- Insert the block of each principal detail drawing view into the assembly drawing file.

Option 3:

- Copy the principal drawing view from each detail drawing and paste the view into the assembly drawing view.
4. If needed, move each detail view into place to form an assembly. Use specific coordinate values or drawing aids, such as object snaps, to position the drawing views accurately.
  5. After you assemble all the detail views, use editing commands such as ERASE and TRIM to clean up the assembly.
  6. Add balloons, notes, and dimensions as needed.
  7. Add the parts list. Use an existing parts list that can be easily modified, or create a new parts list using the TABLE command.

This method saves significant time because you do not have to start over again, drawing each part in the assembly.

Engineering change documents are used to start the revision process and record changes to products in the manufacturing industry. Changes to engineering drawings can be requested from any branch of a company that deals directly with production and distribution of the product. For example, the engineering department can apply product changes as research and development results show a need for upgrading. Manufacturing requests change as problems arise in product fabrication or assembly. The sales staff can also initiate change proposals that come from customer complaints and suggestions. Engineering changes are treated similarly to original drawings. Engineering changes are initiated, approved, sent to the drafting department, and filed

when completed. It is a good idea to leave the area below the revision block clear for future changes, but you can change the sheet size to accept additional views, drawing content, or engineering change documentation as needed to complete the change request.

### Engineering Change Request (ECR)

An **engineering change request (ECR)** is the document used to initiate a change in a part or assembly. Before a drawing can be changed by the drafting department, an ECR is

## ASSEMBLY DRAWINGS

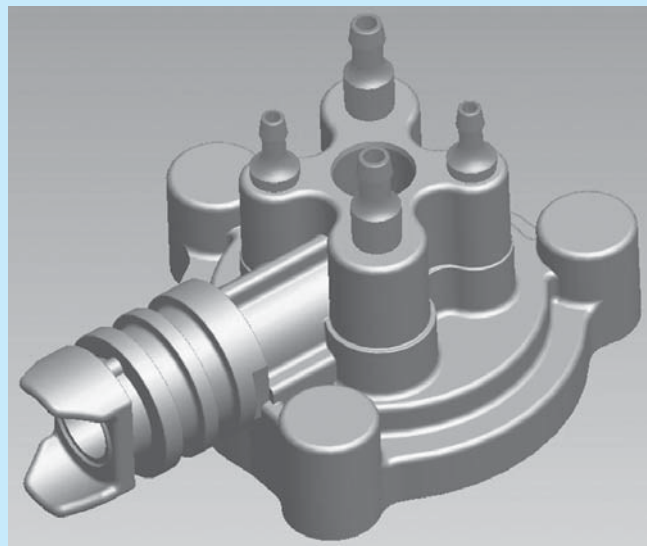
You reference and assemble part and subassembly models in the 3-D modeling environment to form an assembly model. Assembly models are excellent for design and visualization, such as observing the interaction of assembly components, and for creating exploded assemblies and assembly presentations. In addition, you can use assembly models to produce assembly drawings. Three-dimensional modeling software that combines 2-D drawing capabilities usually allows you to produce several types of assembly drawings, depending on the purpose and company standard, including weldment drawings complete with weld symbols and representations. Chapter 18, *Welding Processes and Representations*, covers weld symbols and representations.

Creating an assembly drawing with 3-D modeling software is quick and easy, because all the information needed to produce the drawing is already available in the model. Developing an assembly drawing based on a 3-D model typically involves the following steps:

1. Create a new drawing file based on a drawing file template. The drawing file usually contains or allows you to specify a sheet that represents a specific paper size, and it also contains a border, title block, general notes, and other necessary sheet content.
2. Place and scale drawing views associated with an assembly model. Depending on the software, you may be able to select an option or reference a separate file that displays assembly views in a general, layout, or exploded format.
3. Add a parts list, identification numbers, and other dimensions and specifications as needed.

Figure 15.28a shows the 3-D solid model used to create the 2-D assembly drawing shown in Figure 15.28b. This assembly drawing is the first sheet in a set of working drawings.

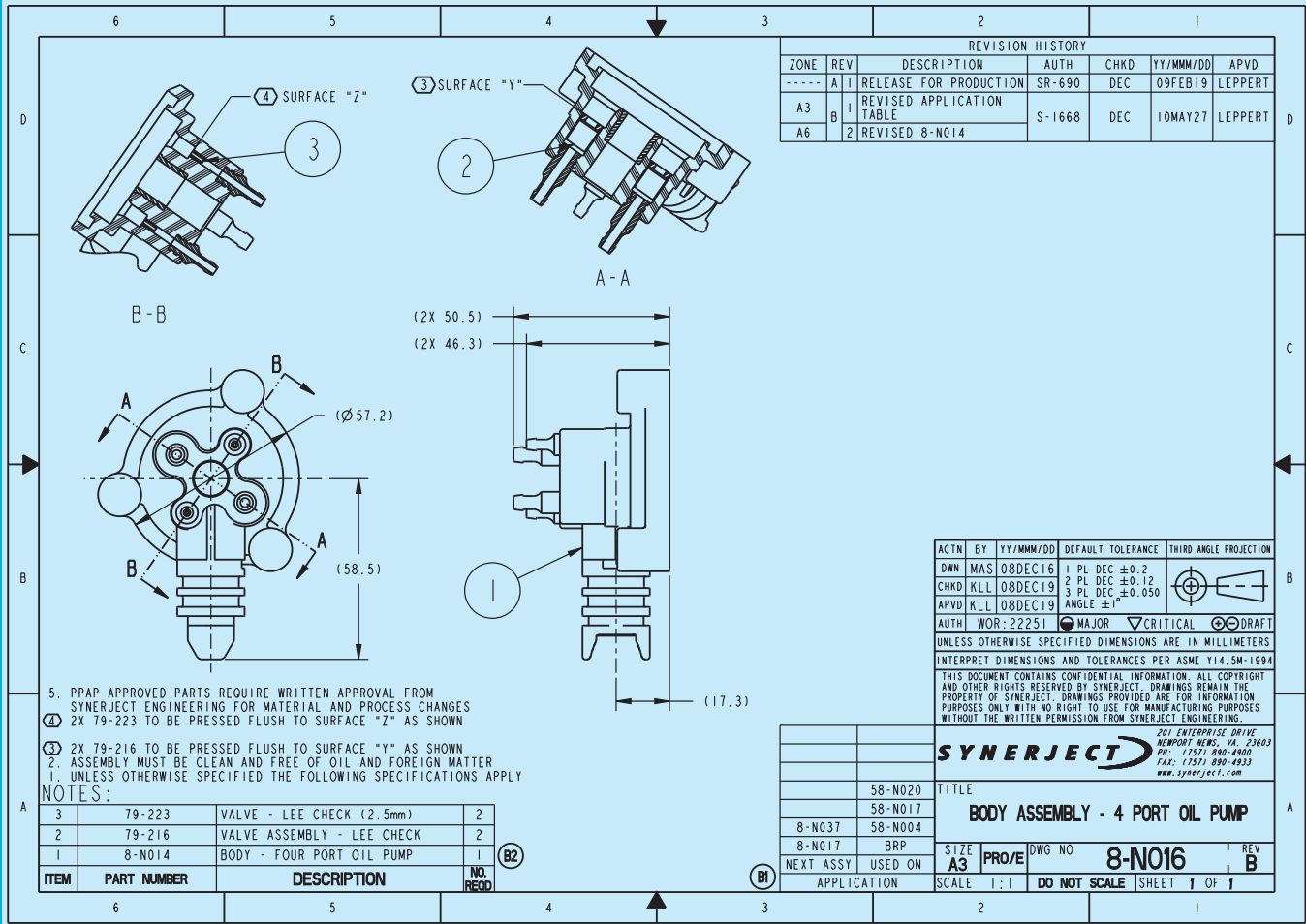
Because of the parametric nature of 3-D modeling software, all the information displayed in the parts list is associated with the assembly model, which is associated with each of the assembly components, and as a result, the detail drawings. When you create a parts list, all the required data is automatically added, and all you have to do is select a location for the parts list. For example, if four of the same items are displayed in an assembly, then a quantity of four is automatically established in the quantity area for the item in the parts list. Additional information, including the part number, description, and material, is referenced from each component file, eliminating the need to type information in the parts list. Then, when you place balloons, the identification numbers or letters are correlated with the parts list and are automatically defined.



(a)

**FIGURE 15.28** (a) A 3-D solid assembly model. (b) A 2-D assembly drawing created by referencing the model shown in Figure 15.28a. Courtesy Synerject North America, Newport News, Virginia

(Continued)



(b)

FIGURE 15.28 (Continued) Courtesy Synerject North America, Newport News, Virginia

## WORKING DRAWING SHEETS

A set of working drawings usually contains several sheets. A simple product may only require an assembly drawing and one or two detail drawings, whereas a complex product can include separate assembly drawings, subassembly drawings, and hundreds of detail drawings. All the sheets in a set of working drawings must be labeled correctly and linked with the other sheets in the set. A single drawing file can be used to produce a set of working drawings, because you can add multiple drawing sheets to a single file. Drawing sheets are used in the same way that pieces of paper are used to

document a set of working drawings. Often an entire design can be documented using one drawing file and multiple drawing sheets. The advantage to using this system is that all the drawings are contained in a single file and are automatically linked together. For example, the order of sheets in the drawing file can be used to define the sheet number in the title block. If there are four sheets in the drawing, the first sheet is automatically labeled 1 of 4 in the title block, and the last sheet is labeled 4 of 4 in the title block. To modify the sheet arrangement, you can drag a sheet before or after another sheet, and the sheet numbers in the title block automatically update according to the new configuration.

needed. Figure 15.29 shows a sample ECR form. Although ECR forms differ between companies, they have similarities. The ECR is usually attached to a print of the part to be revised. The print and the ECR show by sketches and written instructions what changes are to be made. The ECR also contains a number that becomes the reference record of the change to be made.

## Engineering Change Notice (ECN), Engineering Change Order (ECO) or Change Order (CO)

Records of changes are kept so reference can be made between the original, the existing, and the revised parts and products. To make sure records of these changes are kept, special notations



Aerojet Liquid Rocket Company

**ENGINEERING CHANGE REQUEST & ANALYSIS**

				DATE	ECRANG	PAGE		
ORIGINATOR NAME		DEPT	EXT	DATE	DOCUMENT NEED DATE	PROPOSED EFFECTIVITY		
PART DOCUMENT NO	CURRENT REV TR	PART DOCUMENT NAME						
USED ON NEXT ASSY NO	PROGRAMS AFFECTED			PROGRAMS AFFECTED				
				QTSS ITEM	YES	NO		
				REQUAL REQD	YES	NO		
			REVISE QTSS FORM	YES	NO			
DESCRIPTION OF CHANGE								
JUSTIFICATION OF CHANGE								
PROJECT ENGINEER SIGNATURE		DEPT	EXT	DATE	CCB REP SIGNATURE			
DESIGN ENGINEERING TECHNICAL EVALUATION								
DESIGN ENGINEER SIGNATURE		DEPT	EXT	DATE	CAUSING CONT OR WORK ORDER NO			
ANY AFFECT ON	YES	NO		YES	NO			
1 PERFORMANCE			5 WEIGHT			9 OPERATIONAL COMPUTER PROGRAMS		
2 INTERCHANGEABILITY			6 COST SCHEDULE			10 RETROFIT		
3 RELIABILITY			7 OTHER END ITEMS			11 END ITEM IDENT		
4 INTERFACE			8 SAFETY EMI			12 VENDOR CHANGE CRITICAL ITEMS ONLY		
CCB DECISION				SIGNATURES		DEPT		
				QUALITY ASSURANCE			CON CUR	DIS SENT
				MANUFACTURING				
				ENGINEERING				
				PRODUCT SUPPORT				
				MATERIAL				
				TEST OPERATION				
CCB CHAIRMAN SIGNATURE	DATE	CLASS I <input type="checkbox"/>	CLASS II <input type="checkbox"/>					
CUSTOMER SIGNATURE	DATE	EFFECTIVITY						

Courtesy Aerojet Propulsion Division

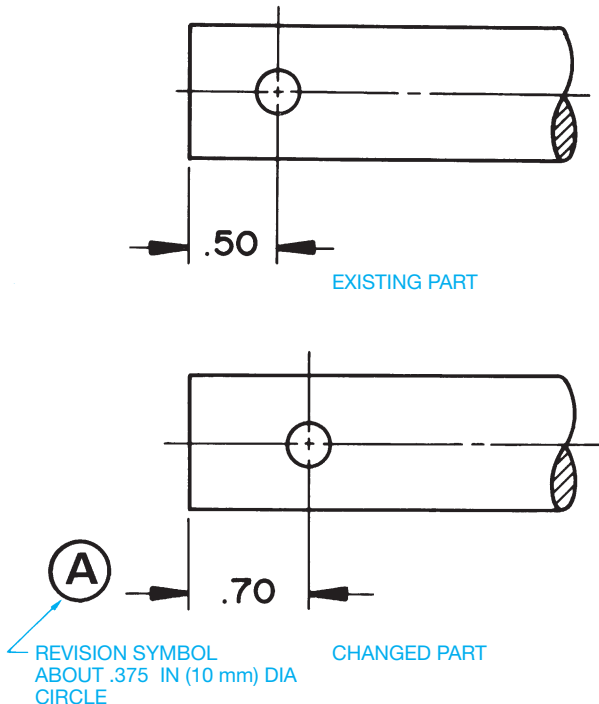
FIGURE 15.29 Sample engineering change request (ECR) form.



are made on the drawing, and engineering change records are kept. These records are commonly known as engineering change notices (ECN), engineering change orders (ECO), or change orders (CO). An ECN, ECO, or CO is a written notification of the change that is accompanied by a drawing representing the change.

### Editing Drawings

When a drawing change is to be made, an ECR initiates the change to the drafting department. The drafter then edits the original drawing or most recent previous revision of the drawing to reflect instructions provided in the ECR. When the drawing of a part is changed, a revision symbol is placed next to the change or changes on the drawing. The revision symbol is a circle with a letter inside. The text in the symbol is between .18 and .24 in. (5–6 mm) in height, and the circle is large enough to fit the text without crowding, such as between .375 and .5 in. (9.5–13 mm). A single ECR can request one or more changes to be made on the drawing, but each change from one ECR has the same revision letter on the drawing. For example, the first change is lettered A, the second change is B, the third change is C, and so on. The letters I, O, Q, S, X, and Z are not used, because they can be mistaken for numbers or other symbols. When all of the available letters A through Z have been used, double letters such as AA and AB or BA and BB are used next. A circle drawn around the revision letter helps the identification stand out clearly from the other drawing text. Figure 15.30 shows a part as it exists and after a change has been made.



**FIGURE 15.30** An existing part feature and the same part feature after a change has been made. Dimension values in this figure are in inches.



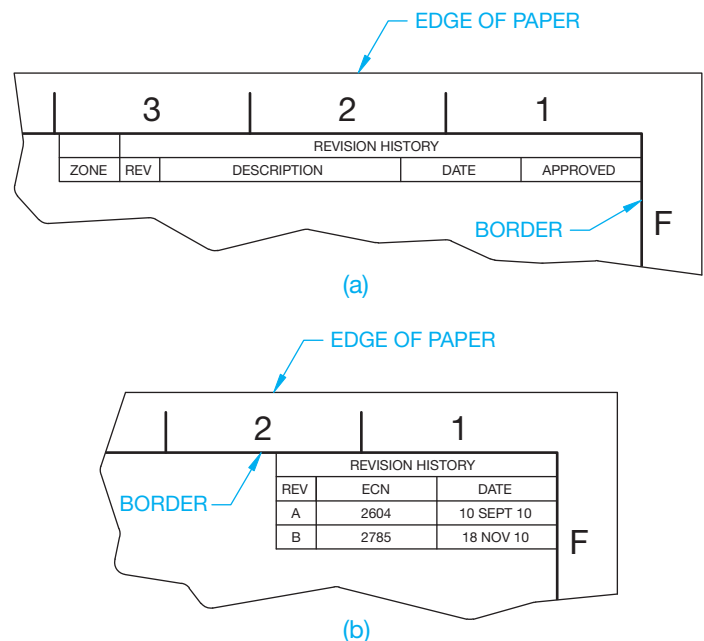
**NOTE:** Some companies use other symbols for revision identification on a drawing. The circle is commonly used, but other symbols, such as a triangle, can also be used.

After the part has been changed on the drawing and the proper revision letter is placed next to the change, the drafter records the change in the revision history block, also known as the *revision block* or *revision column*, of the drawing. The location of the revision history block varies with different companies. The revision history block can be found next to the title block or in a corner of the drawing.

### STANDARDS

**ASME** The ASME document, ASME Y14.1 *Decimal Inch Drawing Sheet Sizes and Format*, and ASME Y14.1M *Metric Drawing Sheet Sizes and Format*, defines the specifications for the revision history block and placement in the upper-right corner of drawing. Refer to Chapter 2, *Drafting Equipment, Media, and Reproduction Methods*, for a complete discussion. ASME Y14.35M, *Revision of Engineering Drawings and Associated Documents*, defines practices for revising drawings and associated documents and also establishes methods for identification and recording revision.

Using the cells within the revision history, the drafter records the revision number as the consecutive number of times the drawing has been revised, ECN number, and the date of the change. An approval box is available to finalize the change. The ECN number is a consecutive number assigned by the company based on the next number available for an engineering change. Some companies also have a column for a brief description of the change as recommended by the ASME standards. Figure 15.31a



**FIGURE 15.31** (a) ASME recommended revision block. (b) Condensed revision block used by some companies.

shows an expanded and condensed ECN column format. Notice that changes are added in alphabetical order from top to bottom.

The condensed ECN column in Figure 15.31b shows the drawing has been changed twice. The first change was initiated by ECN number 2604 on September 10, 2010, and the second by ECN 2785 on November 16, 2010. The number of times a drawing has been changed can also be identified by providing the letter of the current change in the title block as shown in Figure 15.32. The drafter updates this letter to reflect each change.

When the drafter has made all of the drawing changes as specified on the ECR, then an ECN, ECO, or CO is filled out. The ECN completes the process and is filed for future reference. Usually, the ECN completely describes the part as it existed before the change and describes the change that was made. The description content found on the ECN normally matches the

information presented on the ECR. Figure 15.33 shows a typical ECN form. With a changed drawing and a filed ECN, anyone can verify what the part was before the change, information about the change, and the reason for the change. The ECN number is a reference for reviewing the change. This process allows the history of a product to be maintained.

The general engineering change elements, terminology, and techniques are consistent among companies, although the actual format of engineering change documents can be considerably different. Some formats are very simple, whereas others are much more detailed. One of the first tasks of an entry-level drafter is to become familiar with the specific method of preparing engineering changes.

### Not-to-Scale Dimensions

When the drafter chooses to make the change by not altering the drawing of the part but only by changing the dimension value, that dimension is labeled **not-to-scale** and the not-to-scale symbol is used as shown in Figure 15.34. The not-to-scale symbol is a thick straight line placed under the new dimension value. This practice is generally not used with CADD. It is easy and preferred to make the change to scale and avoid using the not-to-scale method with CADD. In addition, dimensions on CADD drawings can be parametric, which means that a change made to dimensions on the 2-D drawing are automatically updated on the 3-D model, and a change made to dimensions on the 3-D model are automatically updated on the 2-D drawing. However, the not-to-scale symbol can be used on a dimension value when it is not possible to update the feature for some reason. When used on a basic dimension, the not-to-scale symbol is placed below the basic dimension symbol. If you see the not-to-scale symbol on an older manual drawing, the dimension value was probably changed without changing the scale of the actual part geometry to match the dimension change. The not-to-scale symbol was likely used to save time, because changing the geometry required erasing and redrawing.

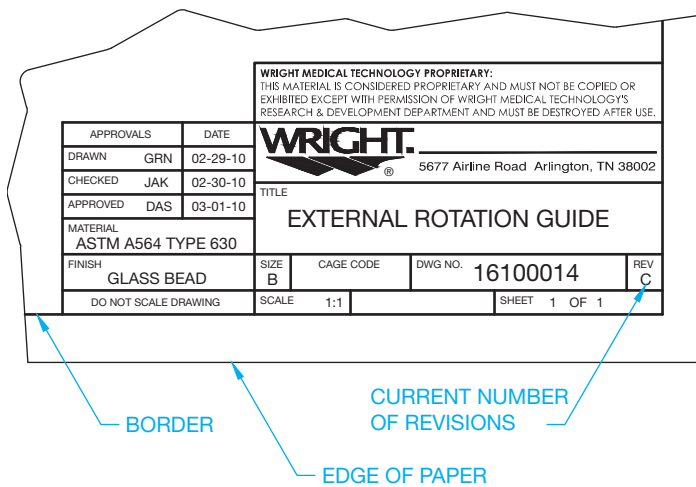
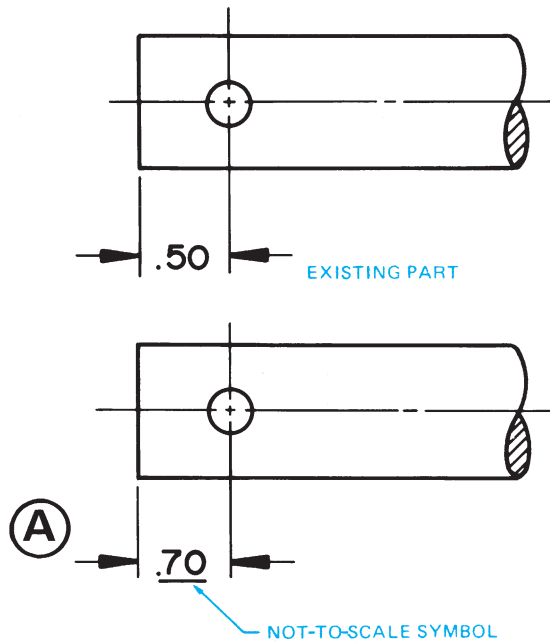


FIGURE 15.32 Title block displaying the current number of times the drawing has been changed. Courtesy Wright Medical Technology, Inc.

The image shows a "DOCUMENT CHANGE NOTICE" form for Aerojet TechSystems. It includes fields for document type (ACDN or DCN), date, ECRA number, release date, and document title. It also has a table for approvals with columns for SH, ZONE, ITEM, DESIGN, DESIGN ACTIVITY, CHECK, STRESS, and WT. The form is partially filled out with handwritten information.

<input type="checkbox"/> ACDN	<input type="checkbox"/> DCN	DATE	<b>DOCUMENT CHANGE NOTICE</b>				DWG LVL	DWG FORM	DOCUMENT NUMBER	REV LTB
ECRA NO		RELEASE DATE	 AEROJET <b>TechSystems</b> COMPANY SACRAMENTO CALIFORNIA FSCM NO 05824				DOCUMENT TITLE			SHEET OF
PREPARED BY							APPROVALS			
SH	ZONE	ITEM	DESIGN	DESIGN ACTIVITY	CHECK	STRESS	WT			
						MAT'L	CMO			

FIGURE 15.33 Sample engineering change notice (ECN). This document is also referred to as an *engineering change order* (ECO) and *change order* (CO). Terminology can vary. The terminology used by the company document in this example is *document change order*. Courtesy Aerojet Propulsion Division



© Cengage Learning 2012

**FIGURE 15.34** An existing part and the same part changed using the not-to-scale symbol. The not-to-scale symbol may be found on archive drawings, but it is not used today. Dimension values in this figure are in inches.

## Engineering Change Redraw

The drawing revision process previously discussed provides for each drawing change to be documented with a drawing revision containing a revision symbol with a letter inside a circle at the change and correlated to the same revision letter in the revision block where a description of the change is provided. After a few months or years, depending on the product, the revisions can get so numerous that the drawing is cluttered with revision balloons and revision block content. When the clutter gets extensive, the company may decide to do a redraw. *Redraw* means that all the revision identification is removed and the drawing continues at the current state as a clean drawing without any changes. The redraw process is easy with CADD, and all previous engineering change documentation is kept for future reference.

## DRAWING FROM A PROTOTYPE

Occasionally, the engineering drafter has to take an existing product or structure and draw a set of working drawings. This set of working drawings can be created from a prototype. A **prototype** is a model or original design that has not been released for production. The prototype is often used for testing and performance evaluations. In most cases, there are prototype drawings from which the prototype was built, but during the modification process, changes may have been made to the prototype. Your job is to complete the production drawings, which are the set of working drawings established by

measuring the prototype, redrawing the prototype drawings with changes, or a combination of these methods. These drawings are often referred to as **as-built drawings**, because they are developed from existing items or products. In this type of situation, you need to be well versed in the use of measuring equipment such as calipers, micrometers, and surface gages. You need to consult with the engineer, the testing department, and the shop personnel who made any modifications to the prototype. With this research, you can fully understand how the new drawings should be created. Be careful to make the drawings accurate and take into account the manufacturing capabilities of your company. After completion, the set of working drawings is checked by the checker and the engineer before the product is released for production. Once the product is released for production, changes are often costly because tooling and patterns may have to be altered. These types of changes are usually submitted as engineering change requests as previously described. Engineering change requests must normally be approved by the engineering and manufacturing departments.

## ANALYSIS OF A SET OF WORKING DRAWINGS

The following discussion takes you through the typical procedures that take place through the life of a set of working drawings, including:

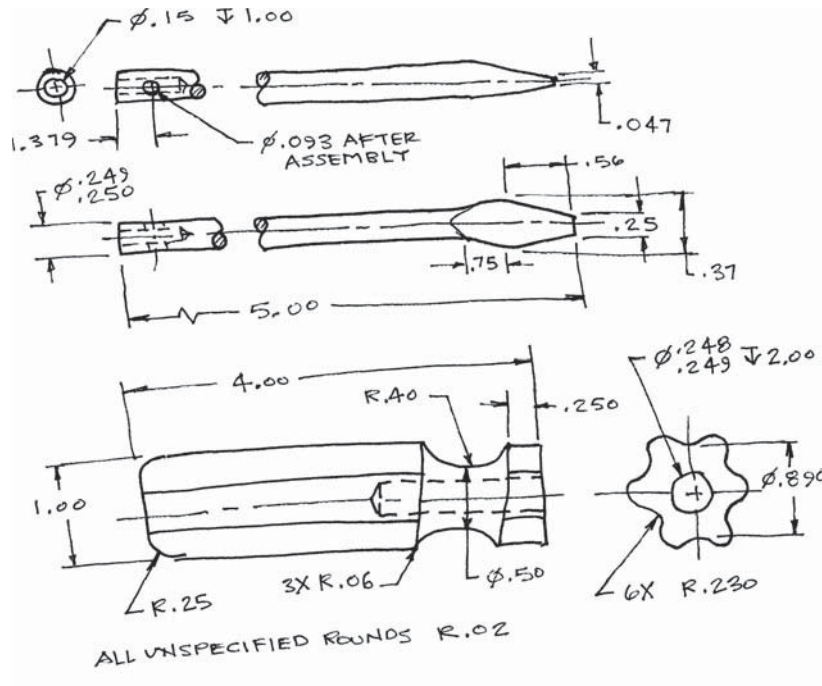
- Create a product idea using research and rough sketches.
- Prepare a complete set of working drawings, including the detail drawings, assembly drawings, and parts list.
- Develop content for a product catalogue.
- Make and document engineering changes as needed.

## The Design Sketches

The design of a product generally begins in the R&D department of a company. The engineer or designer can prepare engineering sketches or layout drawings to help generate concepts for the project. Figure 15.35 shows the engineer's rough sketches for a screwdriver to be manufactured by the company. It is common for the such sketches to be rough, because engineers do not want to waste valuable time. It is your responsibility, as a professional drafter, to prepare the final drawings in accordance with ASME, MIL, AWS, or the appropriate standards adopted by the company.

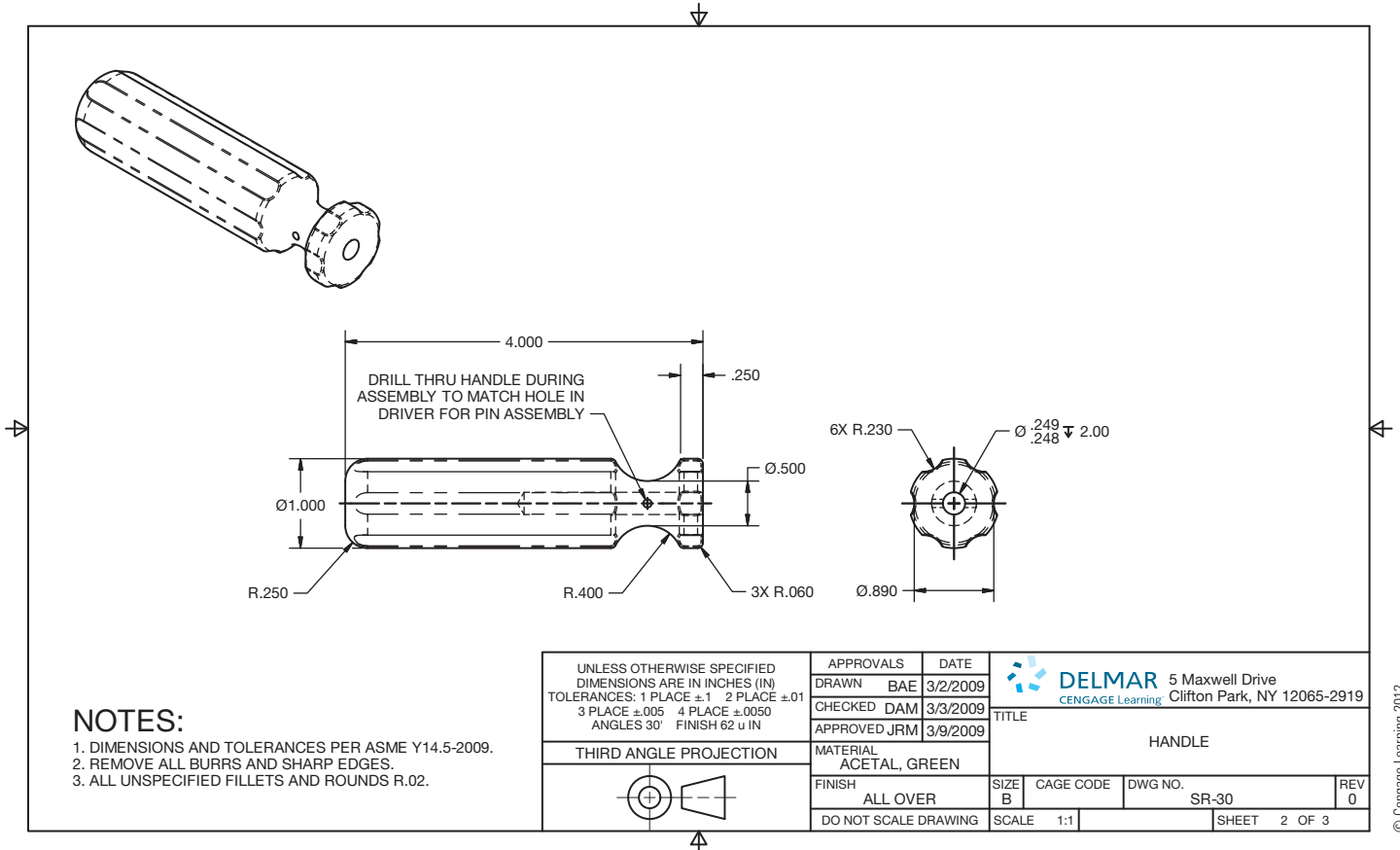
## The Detail Drawings

The engineer's sketches go to the drafting department for the preparation of formal drawings. Depending on the complexity of the project, you and the engineer may work together, or there can be a team of engineers and drafters working on various components of the project. Your first job is to complete the detail drawings as shown in Figures 15.36 and 15.37.



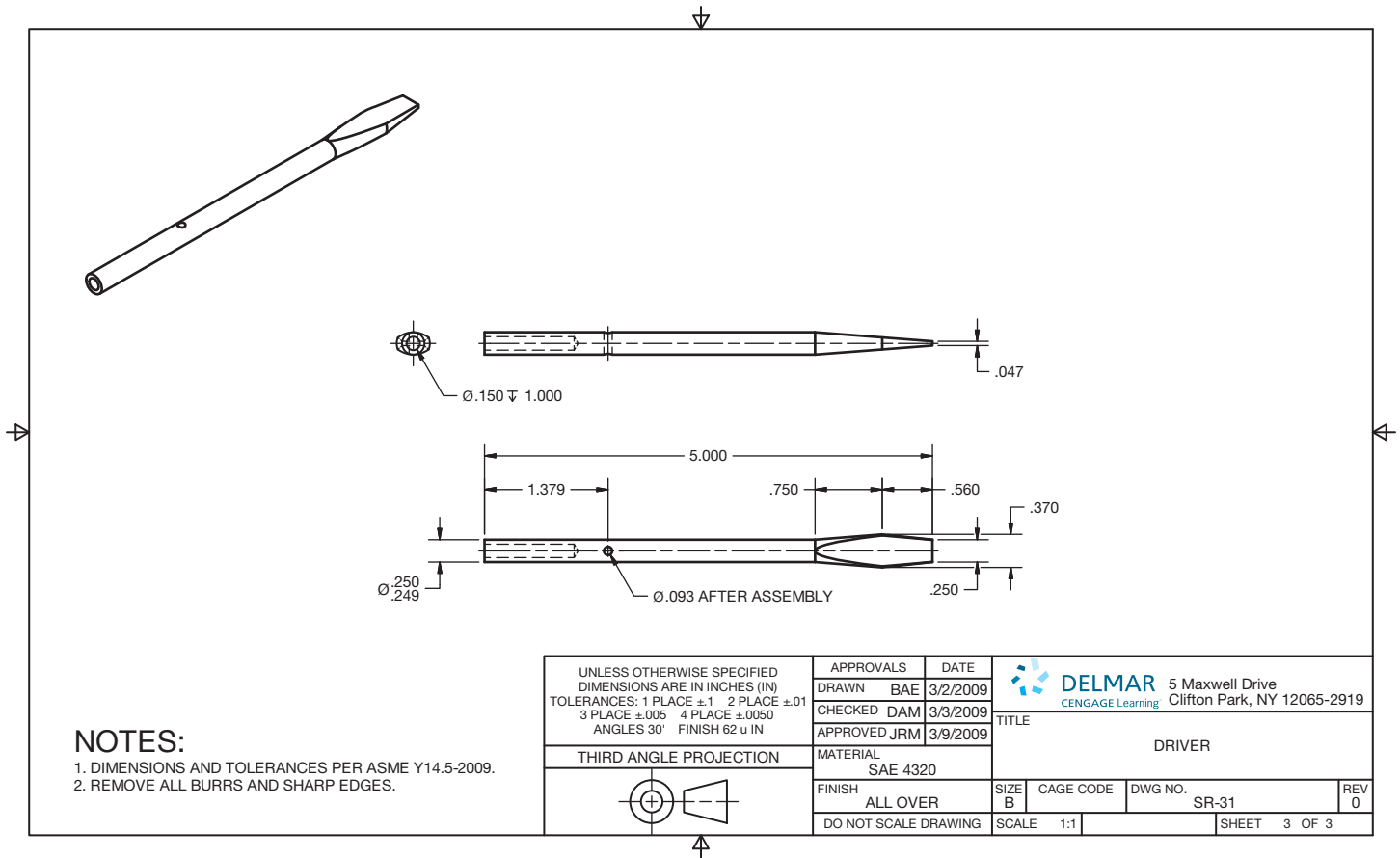
© Cengage Learning 2012

**FIGURE 15.35** A rough engineer's sketch can contain unintentional errors. Typical engineering sketches may not be as good as the one in this example. The engineering drafter must convert the sketch to proper ASME, MIL, or ISO standards as appropriate. Dimension values in this figure are in inches.



© Cengage Learning 2012

**FIGURE 15.36** The original HANDLE detail drawing based on the engineer's sketch before an ECR is issued. Notice the zero (0) in the lower-right corner. This indicates an original unchanged drawing. Dimension values in this figure are in inches.



**FIGURE 15.37** The original DRIVER detail drawing based on the engineer’s sketch before an ECR is issued. Notice the zero (0) in the lower-right corner. This indicates an original unchanged drawing. Dimension values in this figure are in inches. © Cengage Learning 2012

There are two detail drawings needed for the screwdriver product. Figure 15.36 shows the completed detail drawing of the HANDLE, and Figure 15.37 shows the completed detail drawing of the DRIVER.

### The Assembly Drawing and Parts List

As described earlier in this chapter, the assembly drawing is used to show the assembly department how the parts fit together and if there are any special instructions required for the assembly process. When CADD is used, you often freeze the dimensions and isolate the individual parts, which are brought together in a separate assembly drawing. Using CADD allows you to scale the parts into one common size and then move them together in the assembled positions. Assembly notes and dimensions, if any, are added. Each part receives a balloon and a correlating parts list is created as shown for the screwdriver design in Figure 15.38. As you look at Figure 15.38, notice that the assembly drawing has two process notes. The note on the left requires the HANDLE hole to be filled with epoxy prior to assembly. This helps secure the DRIVER in

the HANDLE. The note on the right is a process note that drills through the HANDLE, matching the existing hole in the DRIVER. The PIN is then pressed into the hole, providing additional connection between the HANDLE and the DRIVER. The PIN does not require a detail drawing, because it is a purchase part. A complete description of the PIN is provided in the parts list for use by the purchasing department to purchase the pin from a supplier. When the complete set of working drawings has been drawn and approved, the product is released to production.

### The Product Catalog

The power of 3-D CADD applications makes it possible for companies to display their products using pictorial assemblies or exploded pictorial assemblies. Figure 15.39a shows a pictorial assembly of the screwdriver that was designed in the previous discussion. Figure 15.39b shows an exploded pictorial assembly of the screwdriver that was designed in the previous discussion. These drawings can be used in the company catalogue and marketing information for the screwdriver product.

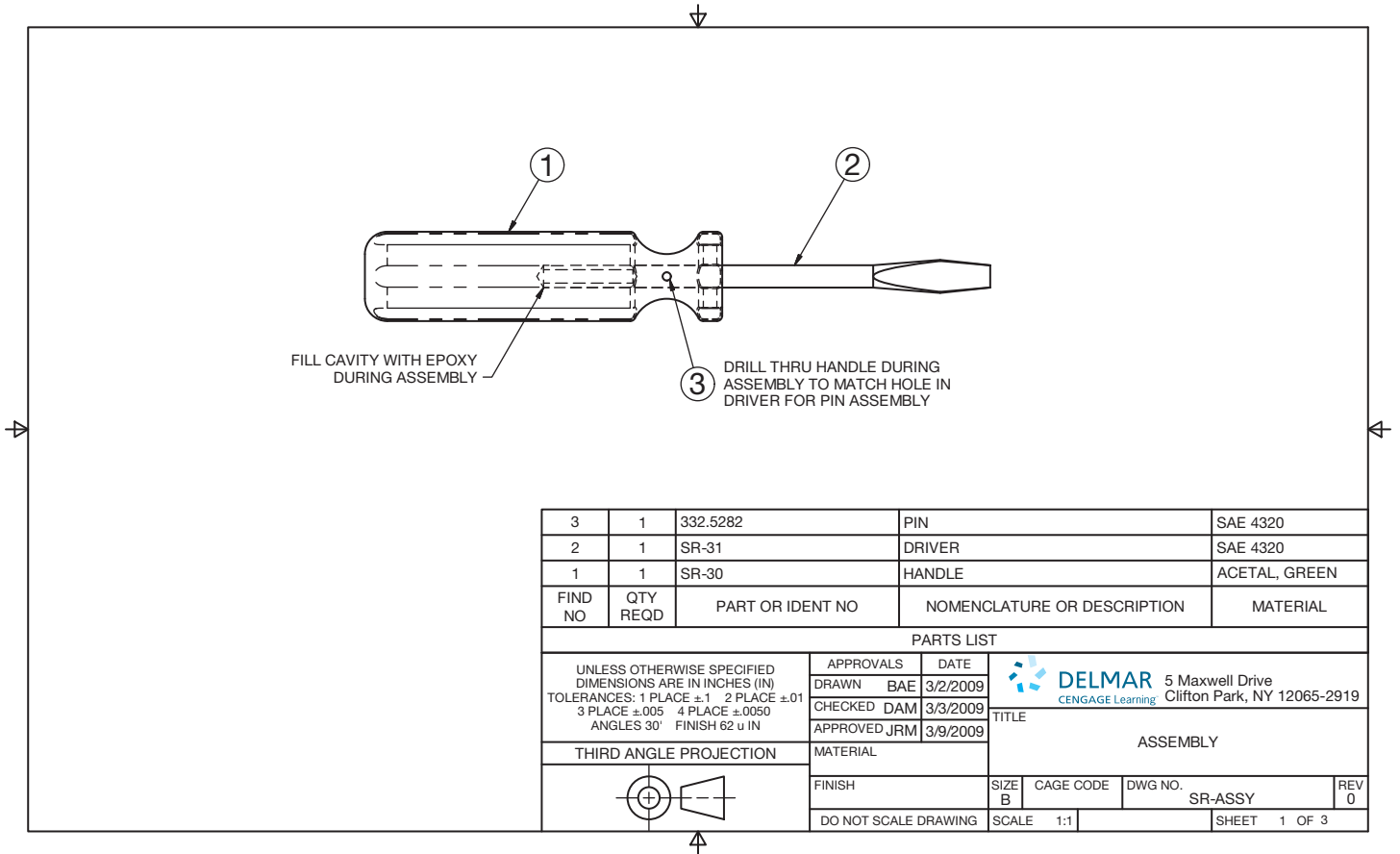
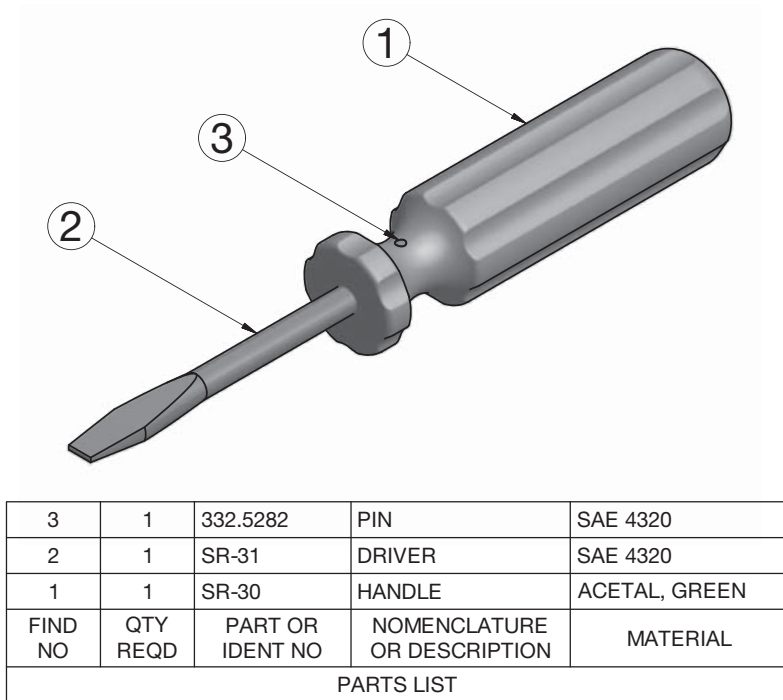
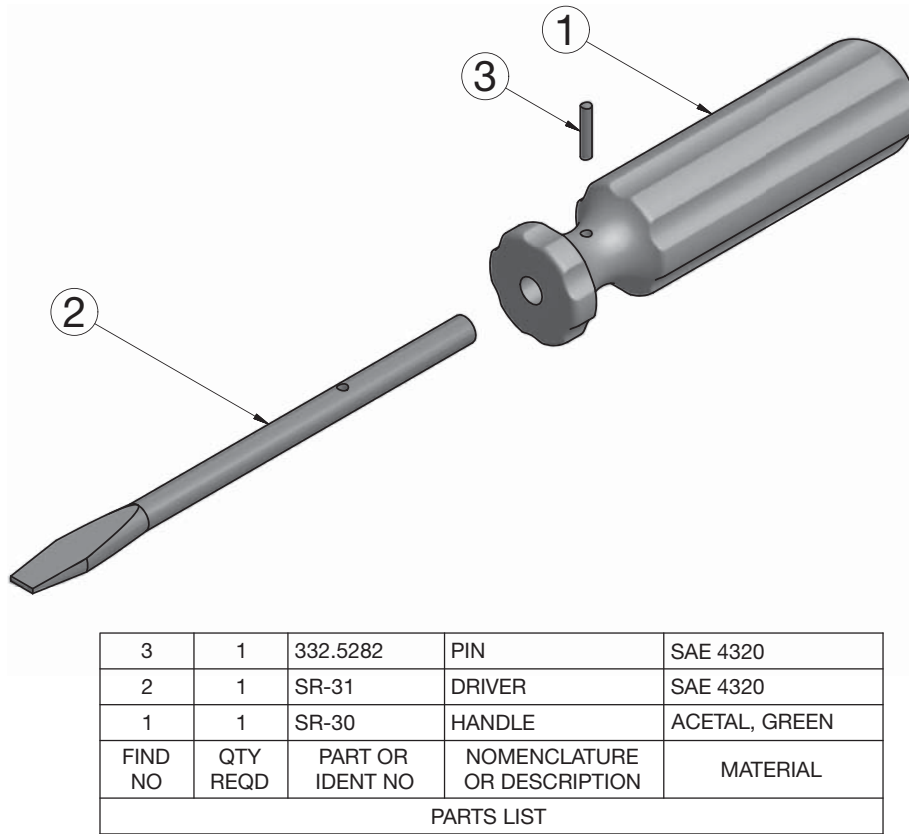


FIGURE 15.38 Assembly drawing for the screwdriver. © Cengage Learning 2012



(a)

FIGURE 15.39 (a) Pictorial assembly drawing of the screwdriver for the company catalog. (b) Exploded pictorial assembly drawing.



© Cengage Learning 2012

(b)

FIGURE 15.39 (Continued)

## Making Engineering Changes

When a product is in production, a change can be requested from any department within the company, including manufacturing, engineering, or sales. Changes can be based on new ways to manufacture, redesign, customer feedback, or any variety of other issues. Before a drawing can be changed by the drafting department, it usually requires an ECR, the document that is used to initiate a change in a part or assembly. The ECR is often attached to a **redlined** print of the part drawing affected. A redline is a print that has been marked up with changes. The print and the ECR normally contain a change number that is used later by the drafter to document the change properly. Every company has an ECR form, and most of them are similar in appearance. The ECR form shown in Figure 15.40 displays an engineering change requested for the DRIVER from Figure 15.36.

After a change is made on the drawing, a revision symbol is placed next to the drawing revision, and a letter identifying the change is placed inside the revision symbol circle. Revision symbol circles are usually 3/8 to 1/2 in. (8 to 12 mm) in diameter, depending on the drawing size. All of the revision symbols are the same size for uniformity on the drawing. Some

companies use a square, a hexagon, or another symbol for revision symbols, but the circle is commonly used. The letter in the revision symbol designates the change. An A is used for the first change, a B for the second change, and so on. Some companies use R1, R2, and R3. However, letters are common to differentiate from balloon numbers on assembly drawings. Next, you record the change in the revision history block of the drawing. The revision history block is usually in the upper-right corner in accordance with ASME standards. The current change is also recorded in the title block as A, B, or C as appropriate. An original drawing generally has a zero (0) in the title block to indicate that no changes have been made. Figure 15.41 shows the DRIVER in Figure 15.36 changed in accordance with the ECR in Figure 15.40.

The next procedure in the change process is for you to fill out the engineering change notice. The ECN is also called *engineering change order* or *change order*. The change documents are a formal part of the drafting process and must be professionally prepared, recorded, and filed for future reference. The ECN is generally prepared electronically using a word processor or CADD system. The ECN form used in companies and the process for filling out the forms vary. Confirm the proper procedure with your employer or instructor. The ECN form in

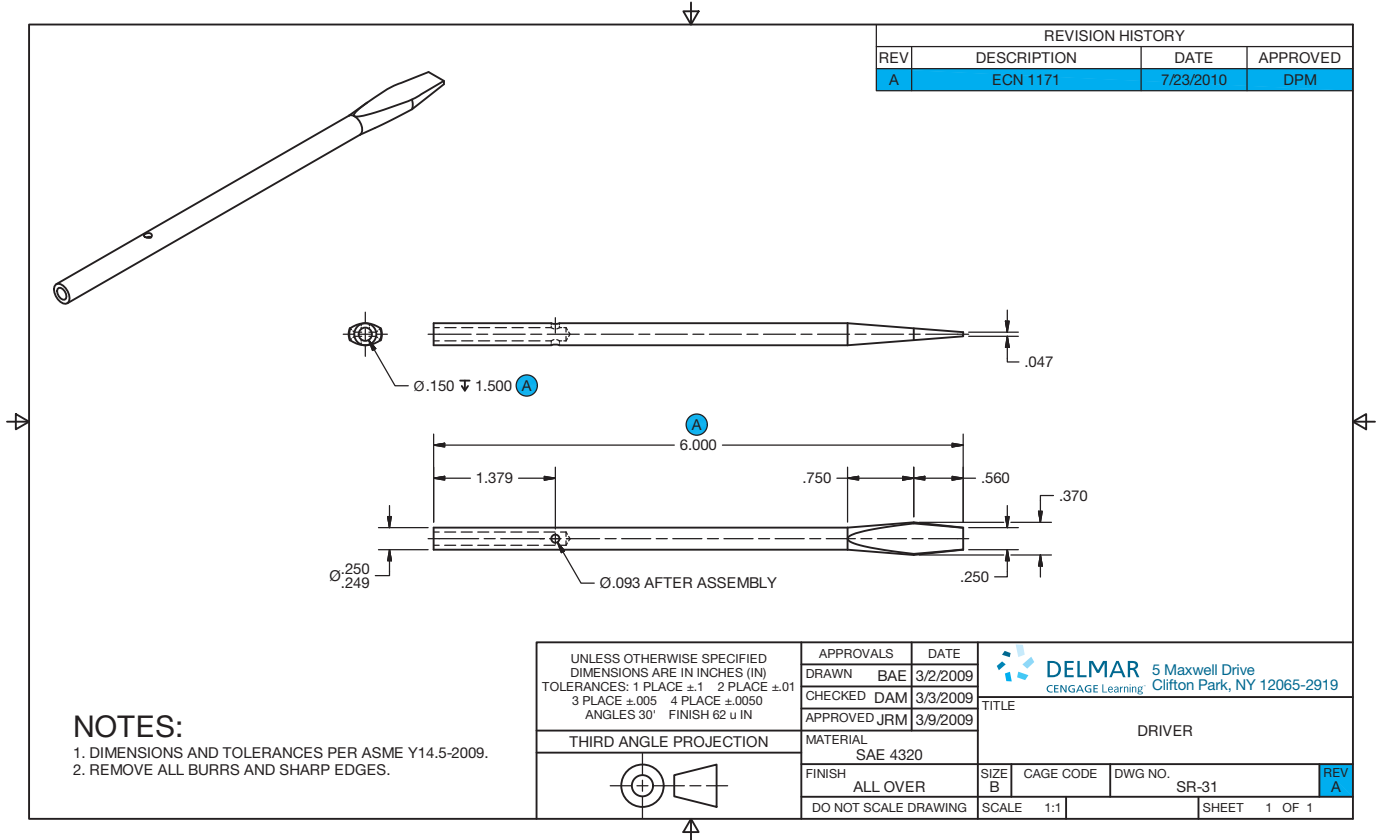
# Engineering Change Request

Request to be completed Through ECN# 1171

Engineering:	Description of Request:		
DAM	Refer to part number SR-31 (Driver)		
	Change 5" length to 6"		
	Change Ø.150 hole depth from 1.000 to 1.500.		
Date: 20 JUL 10			
Manufacturing:			
Date:			
Sales:			
	Reason for Request:		
	Longer tool dimension will make part more stable when locked in handle.		
	Hole depth design error. Additional depth needed for epoxy to access pin.		
Date:			
Castings & Forgings Affected? (yes or no) NO	Disposition of Production Stock: Use in production <input type="checkbox"/>		
Approved:	Date: 20 JUL 10	Drawing by: BAE	Scrap <input checked="" type="checkbox"/> Transfer to service stock <input type="checkbox"/>

© Cengage Learning 2012

**FIGURE 15.40** A sample ECR used in the textbook example.



**FIGURE 15.41** Changes to the DRIVER based on the ECR shown in Figure 15.38. Notice the revision symbols next to each change. Identification of the change is found in the upper-right corner in the revision block, and the current change A is identified in the lower-right corner of the title block. Dimension values in this figure are in inches. © Cengage Learning 2012



Engineering Change Notice

ECN NO. 1171 ①

Disposition of production in stock:  
 A = Alter or rework U = Use in production  
 T = Transfer to service stock S = Scrap

Qty.	Drawing Size Part No.	R/N	Description	Change	Other Usage in Production	D/S
01	1	B SR-31	A	DRIVER	6" was 5"	U
02	②	③	④	⑤	∅.150 hole depth 1.500	⑦
03					was 1.000. ⑥	
04						
05						
06						
07						
08						
09						
10						
11						
12						
13						
14						
15						
16						
17						
18						

Reason: ⑧  
 Line 1—This dimension needed to be longer to help make the part more stable when locked in handle.  
 Lines 2–3 This was a design error. Additional depth needed for epoxy to access pin.

Castings & forgings affected?	Design engineer:	Supervisor approval:	Release date:	Page
<input checked="" type="checkbox"/> Yes <input type="checkbox"/> No ⑧	DAM ⑩	DPM ⑪	23 JUL 10 ⑬	1/1 ⑫

© Cengage Learning 2012

**FIGURE 15.42** The completed engineering change notice (ECN) form. The circled numbers refer to the given steps for completing the ECN form.

Figure 15.42 has been created from a combination of formats found in industry. The large numbers on the ECN refer to the changes requested for the DRIVER in Figure 15.36 and the ECR in Figure 15.40, and they are correlated with the steps used to complete the form. The following steps are used when filling out this ECN form.

- STEP 1** Put the ECN number at the top-right corner of page, on this example. Get this number from the engineering change request. In this case, the ECN number is 1171.
- STEP 2** List quantity of the part affected. On this drawing, one detail part only is affected. *Note:* Quantity = 1.
- STEP 3** List drawing sheet size, such as A, B, C, or D (A0, A1, A2, A3, A4) and the part number. This is a B size sheet, and the part number is SR-31.
- STEP 4** List the revision related to this change. In this case, this is the first change. An original drawing has a zero (0) here. Put the current revision letter such as A, B, C, or D here. Some companies use numbers. This is the first change on this drawing, so an A is used.
- STEP 5** Place the title for the drawing or part here. The title is DRIVER for this drawing.

- STEP 6** Identify the changes you made. Describe the changes made in short terms. The wording should match the information found on the ECR.
- STEP 7** List what is to be done with parts already made under the old design. Use a symbol such as A, U, T, or S to provide this information. The definitions of these letters are conveniently located on the ECR form for reference. The disposition of current parts is to scrap. U = Use in production. This means that all parts already made to the current specifications will be used in production until the supply runs out and then the newly revised parts will be used (see Figure 15.42).
- STEP 8** Identify reasons for the change in brief but complete statements so someone can later find out why the change was made. The wording should match the information found on the ECR.
- STEP 9** Check YES or NO to help the manufacturing department, check if casting or forgings are affected. YES is checked in this case, because the forging die for the driver will need to be modified.

- STEP 10** Initial your name or the initials of the project engineer so if questions arise about the changes, those asking questions know who to query.
- STEP 11** Your supervisor approves the changes you have made.
- STEP 12** Pages are listed as 1/1 for a one-page change document as in this example. An example of a three-page document has the pages numbered 1/3, 2/3, 3/3, or 1 of 3, 2 of 3, 3 of 3.
- STEP 13** The date you made the change is recorded.

The part or product is released again for continued manufacturing after the engineering change documents have been properly prepared and approved.



## Engineering Drawing and Design Math Applications

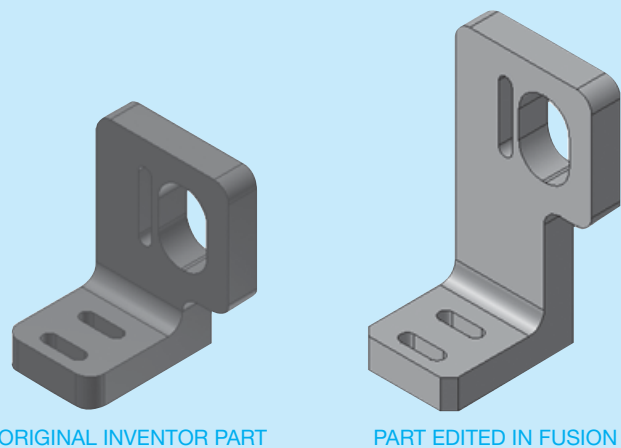
For complete information and instructions for engineering drawing and design math applications, including the law of sines and the law of cosines, go to the Student CD, select **Reference Material** and then **Engineering Drawing and Design Math Applications**.

## DESIGN REVISIONS

CADD offers tools and options that enhance your ability to make accurate design changes, easily document revisions, and improve communication between all individuals involved in a design project. Some CADD software automates the revision process by providing tools that link the engineering change request, the modified models and drawings, and the engineering change notice together in a seamless engineering change system. Some applications take the concept of engineering changes to a new level by providing interactive ways to apply and manage design changes. One example is the Autodesk product Change Manager.

Autodesk Inventor Fusion provides direct modeling workflows for Autodesk Inventor and imported files from other mechanical computer-aided design (MCAD) models. Autodesk Inventor Fusion offers unification of direct and parametric workflows for models created in Autodesk Inventor software, using Change Manager. Change Manager is an Inventor add-in that is installed along with Autodesk Inventor Fusion Technology. The Change Manager add-in allows the user to identify and manage any changes made to a part with Fusion. Change Manager can be used to map nonparametric Fusion edits to editable, parametric Inventor features. Change Manager allows an Inventor part model file (.ipt) to be edited within Inventor Fusion Technology free from the structure of **history-based modeling**. History-based modeling occurs when the software automatically stores each step used in the development of the model and can be used for future reference or for returning back to a specific step to analyze or continue with new design development from there. The Inventor Open Fusion DWG command is used to open the edited model in Inventor. Edits from Fusion can then be accepted or rejected using the Change Manager browser interface provided by the add-in.

The bracket design shown in Figure 15.43 demonstrates an example of how Change Manager works. The original



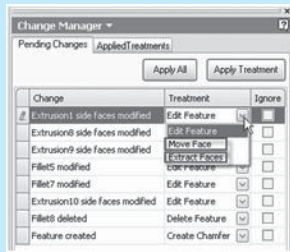
**FIGURE 15.43** An example of a bracket redesigned to replace rounds with chamfers and thus change the overall height of the bracket. *Courtesy Autodesk, Inc.*

parametric model from Inventor has rounds, created using a FILLET tool, on the bottom corners of the bracket. The user opens the part in Fusion, replaces the rounds with chamfers, and changes the overall height of the bracket. The design is then saved back to a Fusion DWG file.

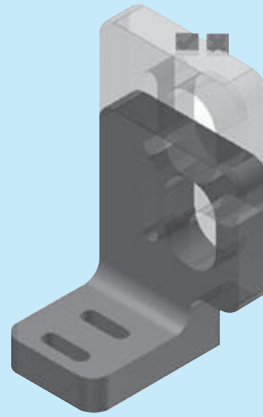
The Change Manager Environment activates when the Fusion DWG file is opened in Inventor. The Change Manager browser, shown in Figure 15.44a, lists eight differences between the original part and the new part. The corresponding model displays the changes (see Figure 15.44b). Deleted rounds are red, newly created chamfers are green, modifications to the faces (old position) are blue, and the new position is yellow.

The Change Manager Environment offers a set of treatments for each change listed in the browser. The preferred treatment is a parametric update to the Inventor model. In the bracket example, the user can Apply Treatment to the Edit Feature for Extrusion1 and Extrusion8. After these two treatments are applied, only two

(Continued)



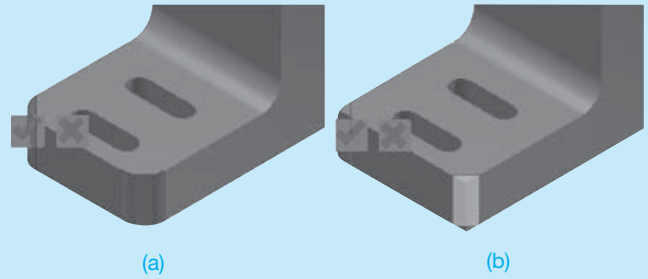
(a)



(b)

**FIGURE 15.44** (a) The Change Manager browser listing pending changes. (b) The corresponding model displays graphical highlighting in the Change Manager environment. *Courtesy Autodesk, Inc.*

remaining changes are detected. After every change to the Inventor model, through either Apply Treatment or direct user edits, Change Manager reevaluates the differences between the Inventor model and the Fusion model. In this case, the wide and narrow radius slots were repositioned by the updates to Extrusion1 and Extrusion8, eliminating these differences. All that remains to be done is to Apply Treatment to the deleted Fillet8 shown in Figure 15.45a and then Apply Treatment to accept the chamfer replacements shown in Figure 15.45b.



(a)

(b)

**FIGURE 15.45** An example of applying treatments to accept changes made to the model. (a) Accepting to delete rounds, or fillets. (b) Accepting to add chamfers. *Courtesy Autodesk, Inc.*

The Change Manager workflow opens up new possibilities for collaboration. For example, a user who is not familiar with the parametric construction of a model can directly edit the model without the need to understand part history. By incorporating these changes back into the original model, the integrity of the original parametric design is preserved. The primary designer can then accept or reject these changes in the context of the overall design.

Change Manager enables very practical applications. A design engineer can send a model to a manufacturing engineer or supplier to gain feedback on the manufacturability of a design. The manufacturing expert can suggest changes to improve the manufacturability of the part and send these changes back to the design engineer. This process can be repeated multiple times, combining the ease of change from direct modeling techniques with the embedded design knowledge of parametric design.

## PROFESSIONAL PERSPECTIVE

Many entry-level drafters are often involved in preparing detail drawings or making changes to detail drawings, assembly drawings, and parts lists. When a drafter has gained valuable experience with drafting practices, standards, and company products, there is often an opportunity to advance to a design drafter position. Drafting jobs at these levels can be exciting, because the drafters work closely with engineers to create new and updated product designs. An individual drafter in a small company can be teamed with an engineer to help create designs. In larger companies, a team

of drafters, designers, and engineers can work together to design new products. These are the types of situations in which a drafter can have the opportunity to prepare some or all of the drawings for a complete set of working drawings. Generally, in R&D departments of companies, the preliminary product drawings are used to build prototypes of the designs for testing. After sufficient tests have been performed on the product, the drawings are revised and released for production. It is an exciting experience when a new product becomes a reality.

### DISTANCE BETWEEN TANGENT CIRCLES

**Problem:** It is desired to find dimension  $z$ , the distance between the centers of the two smaller circles of the illustration shown in Figure 15.46.

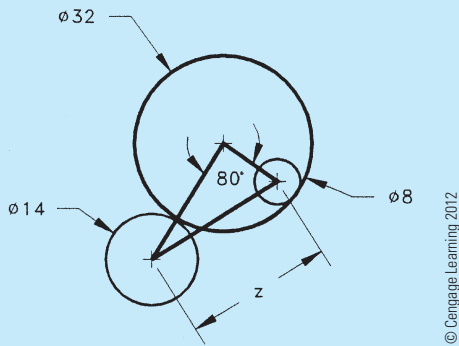


FIGURE 15.46 Tangent circles.

**Solution:** It is necessary to visualize the triangle connecting the centers of the circles and make use of the known radii to calculate two of the sides. The side of the triangle connecting the 32" and 14" diameter circle centers must be the sum of their radii,  $16 + 7 = 23$ ", and the side connecting the 32" and 8" diameter circle centers must be the difference of their radii,  $16 - 4 = 12$ " (see Figure 15.47).

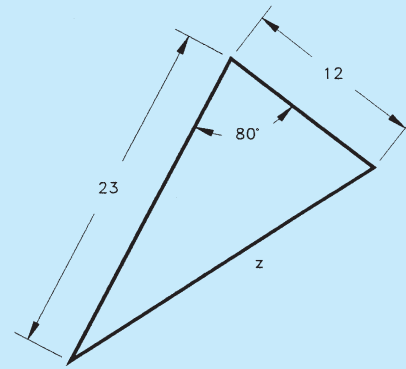


FIGURE 15.47 Oblique triangles for the tangent circles.

**Solution:** Because the triangle is not a right triangle, you cannot use a single trig function, and because you do not know a side *and* the angle opposite the side, you cannot use the law of sines. Instead, you must use the law of cosines:

$$z^2 = (23)^2 + (12)^2 - 2(23)(12)\cos 80^\circ$$

$$z^2 = 529 + 144 - 2(23)(12)(.1736)$$

$$z^2 = 529 + 144 - 95.854$$

$$z^2 = 577.146$$

$$z = \sqrt{577.146} = 24.024 \text{ or } 24.0''$$

### WEB SITE RESEARCH

Use the following Web sites as a resource to help find more information related to engineering drawing and design and the content of this chapter.

Address	Company, Product, or Service
www.asme.org	American Society of Mechanical Engineers (ASME)
www.industrialpress.com	Information about the <i>Machinery's Handbook</i> . Manufacturing materials, standard features, and processes
www.iso.org	International Organization for Standardization
www.sae.org	Find information and publications related to the Society of Automotive Engineers.

## Chapter 15

### Chapter 15 Working Drawings Test

To access the Chapter 15 test, go to the Student CD, select **Chapter Tests and Problems**, and then **Chapter 15**. Answer the questions

with short, complete statements, sketches, or drawings as needed. Confirm the preferred submittal process with your instructor.

# Chapter 15 Working Drawings Problems

## INSTRUCTIONS

1. From the selected engineering sketches or layouts, prepare a complete set of working drawings, including details assembly and parts list. Use appropriately sized standard ASME sheets with border and sheet blocks. Determine which views and dimensions should be used to completely detail each part. In addition, determine the views, parts list, dimensions, and notes, if any, for the assembly drawing. Use ASME standards. The complete set of working drawings should be prepared with one detail drawing per sheet using multiview projection and with the assembly drawing and parts list on one sheet unless otherwise specified. All purchase (standard) parts are completely identified in the parts list. Use the sketches as a guide to draw original multiview drawings on adequately sized sheets. Use drafting applications that you have learned, such as auxiliary views and sectioning techniques, as needed for each drawing. Add all necessary dimensions and notes using unidirectional dimensioning. Many of the problems are designed to be manufactured as projects in the manufacturing (machine) technology department.
2. When using solid modeling software, create the solid model using the given geometry and confirm the accuracy of the given engineering information as you proceed. Consult with your instructor or supervisor if you discover problems with the geometry and revise the drawings as needed to make the geometry accurate and confirm that parts fit together. Use your completed part solid models to develop fully dimensioned 2-D detail drawings. Place a 3-D model in the upper-left corner of the drawing for use as a visualization aid. Assemble the part models and create a 2-D assembly drawing with a correlated parts list.
3. Include the following general notes at the lower left corner of the sheet .5 in. (13 mm) each way from the corner border lines:

## NOTES:

1. DIMENSIONING AND TOLERANCING PER ASME Y14.5-2009.
2. REMOVE ALL BURRS AND SHARP EDGES.

Note number 2 does not normally apply to the assembly drawings. Additional general notes may be required, depending on the specifications of each individual assignment. Use the following for tolerances for unspecified inch values. A tolerance block is recommended as described in Chapter 2.

UNSPECIFIED TOLERANCES	
DECIMALS	IN
X	$\pm .1$
XX	$\pm .01$
XXX	$\pm .005$
ANGULAR	$\pm 30'$
FINISH	125 $\mu\text{in.}$

For metric drawings, provide a general note that states TOLERANCES FOR UNSPECIFIED DIMENSIONS COMPLY WITH ISO 2768-m. Provide a general note that states SURFACE FINISH 3.2  $\mu\text{m}$  UNLESS OTHERWISE SPECIFIED.



**NOTE:** Each problem assignment is given as an engineer's layout to help simulate actual **real-world drafting conditions**. Problems become more complex as you continue.

Dimensions and views on engineers' layouts may not be placed in accordance with acceptable standards. You need to carefully review this chapter and previous chapters material when preparing the layout sketch. In some problems, the engineer's layout *assumes* certain information, such as the symmetry of a part or the alignment of holes. You need to place enough dimensions or draw lines between features to fully dimension each part. In addition, evaluate properly tolerancing between mating components to make sure they fit during assembly. For example, a 1 in. shaft will not always fit in a 1 in. hole, depending on the tolerance applied to the features.

Most of the Chapter 15 problems can be drawn without studying other chapters in this section. However, several of the given problems are advanced and challenging and are best solved after you study all Section Four chapters. If you choose, or if you are assigned to solve these advanced problems, you should study Chapters 16, 17, and 18 as you encounter parts in your problems that relate to content found in those chapters. This is the kind of challenge that you can face in the real world of engineering drafting. Oftentimes you have to go ahead on your own or seek additional instruction when you encounter new and varied obstacles. The following are the types of features that require you to study additional content beyond this chapter:

- Linkages, cams, gears, and bearings in Chapter 16.
- Belt and chain drives in Chapter 17.
- Welding representations and assembly of welded parts in Chapter 18.

*Special Note:* Some problems in this chapter contain errors, missing information, or slight inaccuracies. This is intentional and is meant to encourage you to apply appropriate problem-solving methods, engineering, and drafting standards in order to solve the problems. This is meant to force you to think about each part and how parts fit together in the assembly. As in real-world projects, the engineering problem should be considered as a basis for your preliminary layouts. Always question inaccuracies in project designs and consult with the proper standards and other sources. In some cases, an error might be the source of engineering changes provided by the instructor; but this is determined by your specific course objectives. Other situations require that corrections be made during the development of the original design drawings. This is not intended as a source of frustration but is considered part of the engineering drafter's daily responsibility in project development.

## Drafting Templates

To access CADD template files with predefined drafting settings, go to the Student CD, select **Drafting Templates** and then select the appropriate template file. The ASME-Inch and ASME-Metric drafting templates follow ASME, ISO, and related mechanical drafting standards. Drawing templates include standard sheet sizes and formats and a variety of appropriate drawing settings and content. You can also use a utility such as the AutoCAD DesignCenter to add content from the drawing templates to your own drawings and templates. Consult with your instructor to determine which template drawing and drawing content to use.

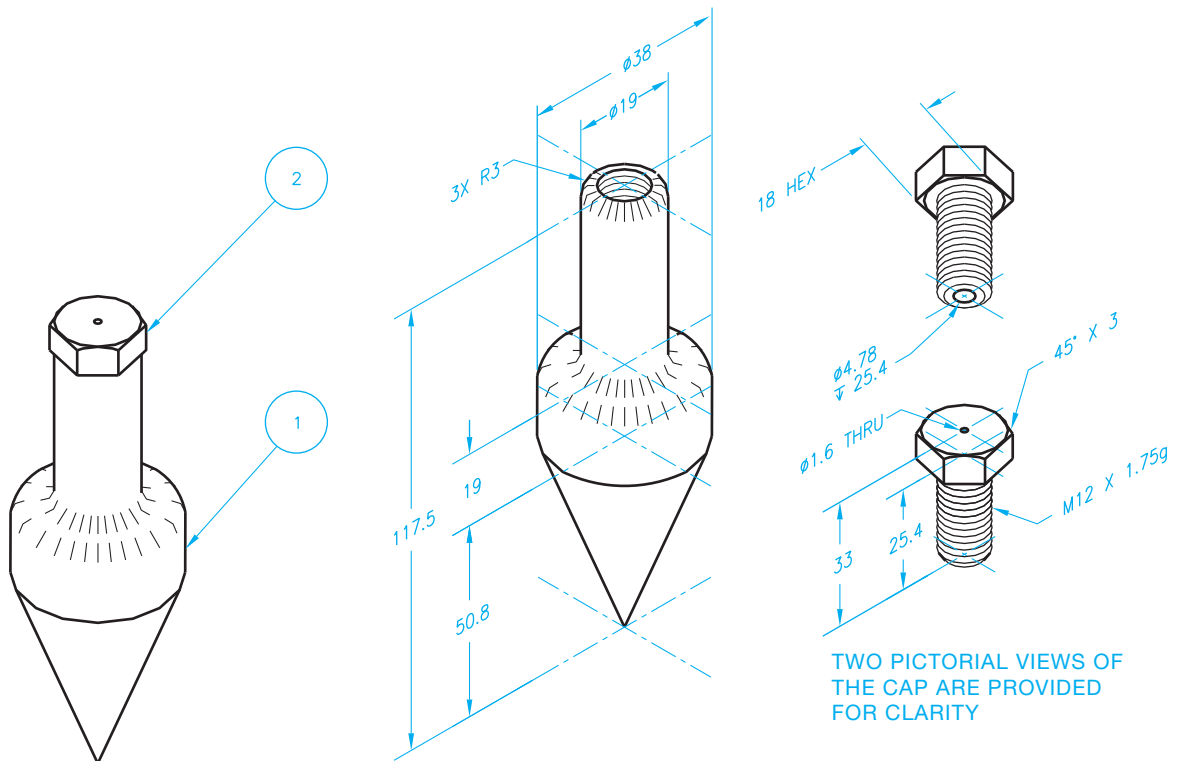
### Part 1 : Problems 15.1 Through 15.22

#### PROBLEM 15.1 Working-drawing assembly (metric)

Assembly Name: Plumb Bob

SPECIFIC INSTRUCTIONS: Prepare a working-drawing assembly that has a detail drawing of each part, an assembly drawing, and a parts list on one sheet.

PARTS LIST			
ITEM	QTY	NAME	MATERIAL
1	1	PLUMB BOB	BRONZE
2	1	CAP	BRONZE

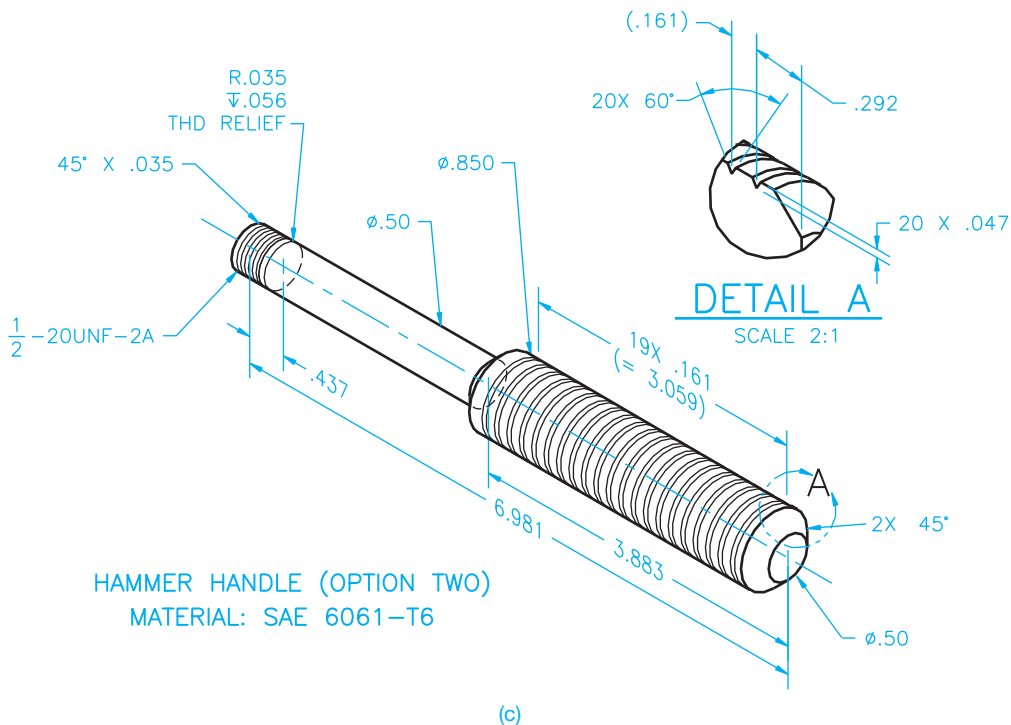
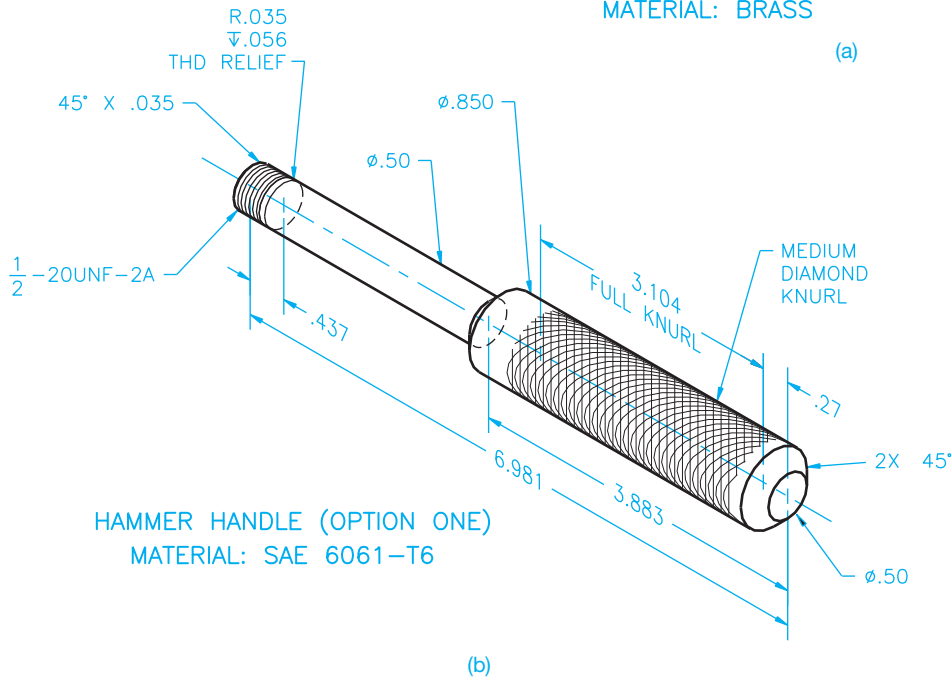
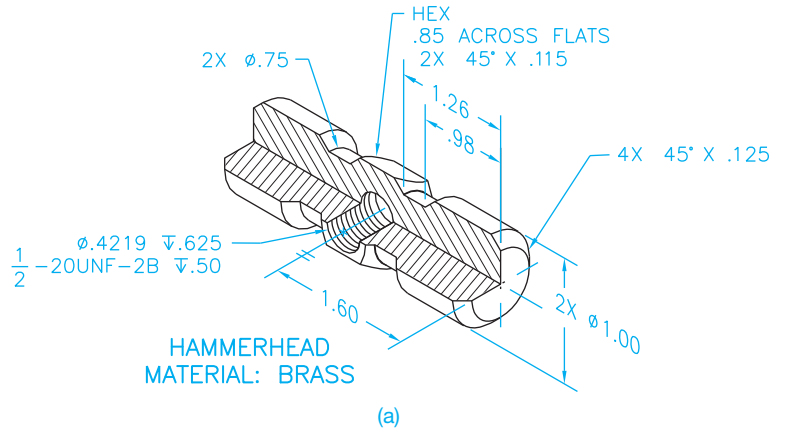


© Cengage Learning 2012

PROBLEM 15.2 Working drawing (in.)

Assembly Name: Hammer

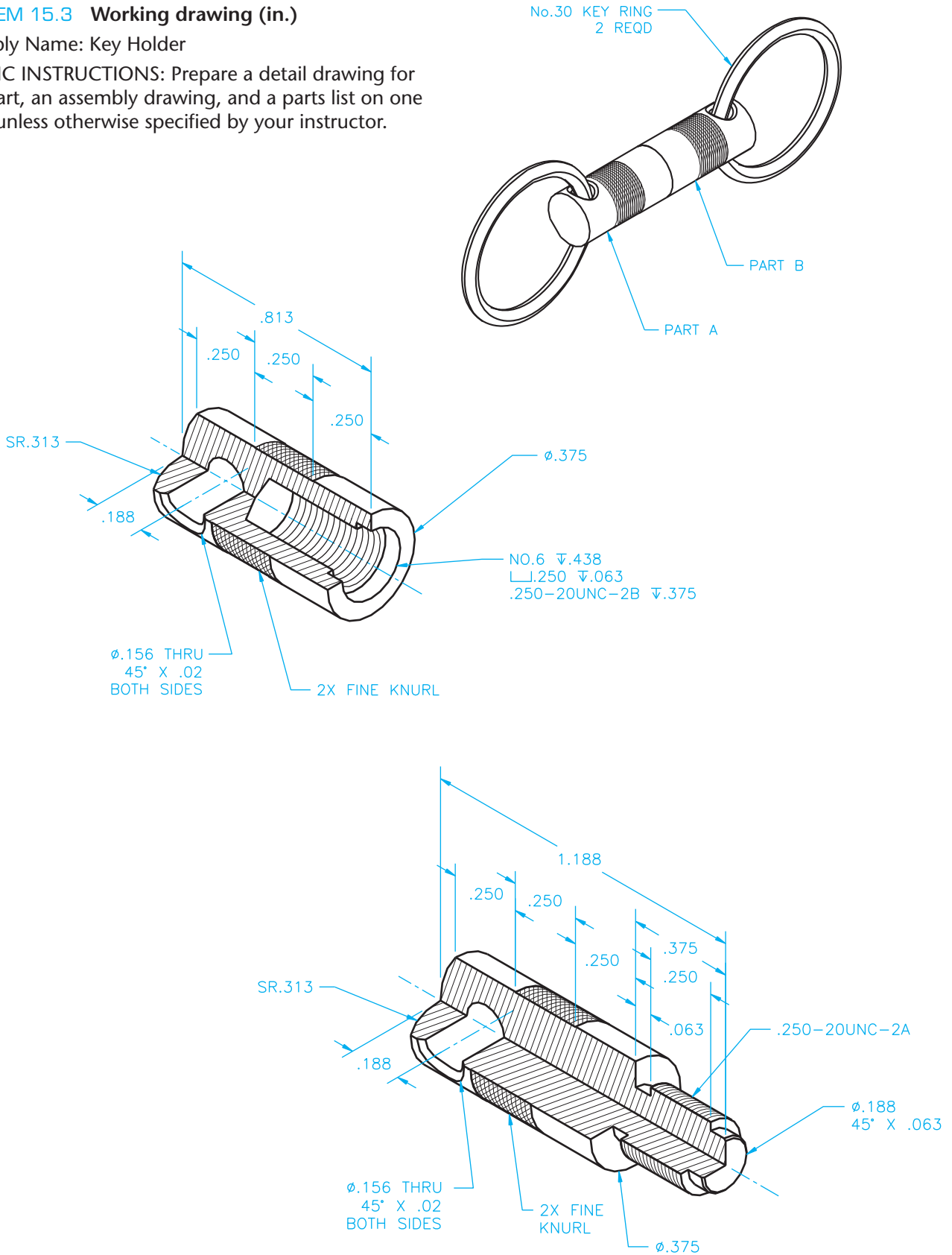
SPECIFIC INSTRUCTIONS: Prepare a detail drawing for the hammer head and two optional hammer handles on one sheet. Make the assembly drawing and parts list on another sheet.



**PROBLEM 15.3 Working drawing (in.)**

Assembly Name: Key Holder

SPECIFIC INSTRUCTIONS: Prepare a detail drawing for each part, an assembly drawing, and a parts list on one sheet, unless otherwise specified by your instructor.



© Cengage Learning 2012

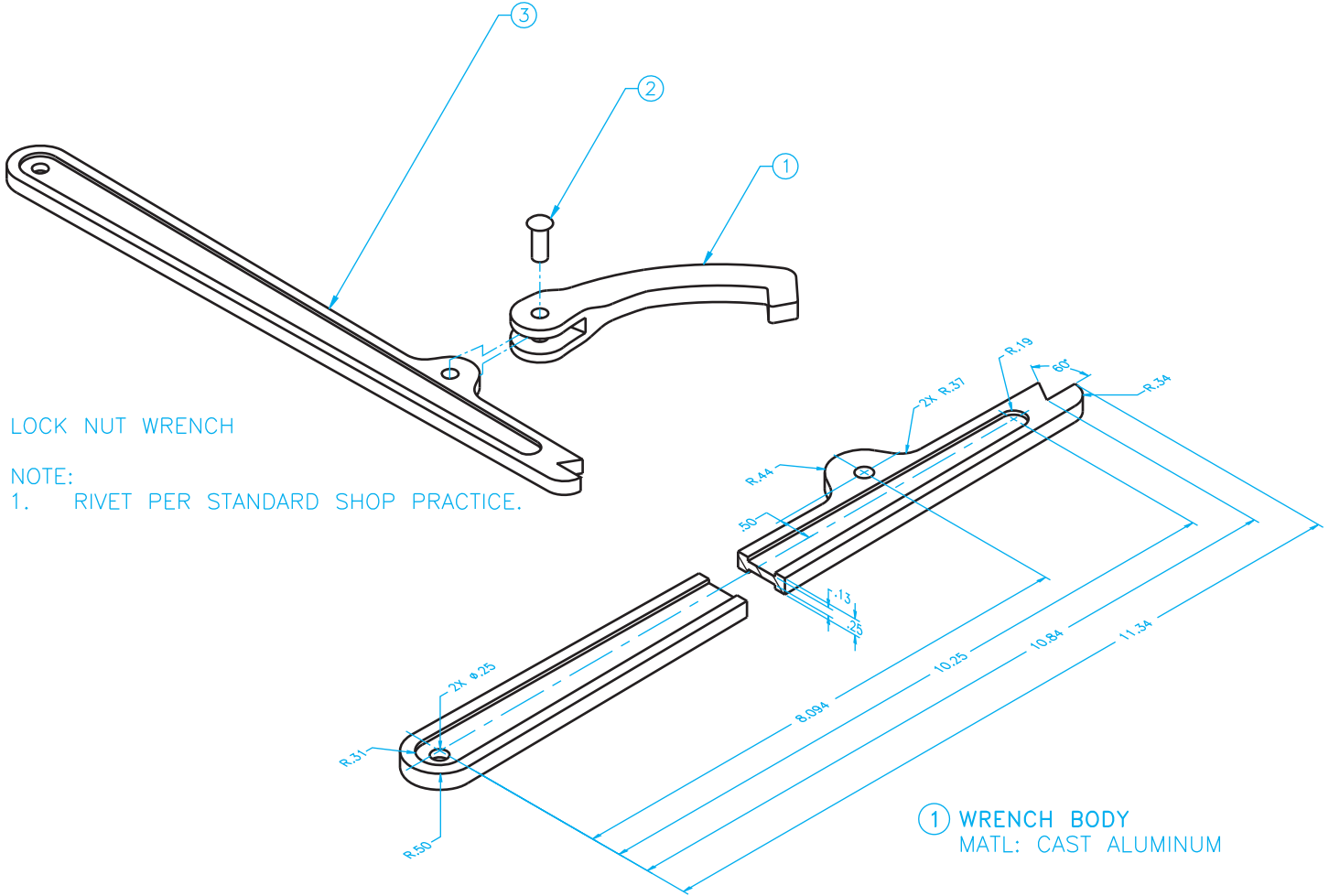


PROBLEM 15.4 Working drawing (in.)

Assembly Name: Lock Nut Wrench

SPECIFIC INSTRUCTIONS: Prepare a complete set of working drawings with all of the detail drawings on one sheet and the assembly drawing and bill of materials on another sheet. Use multiview projection for view layout.

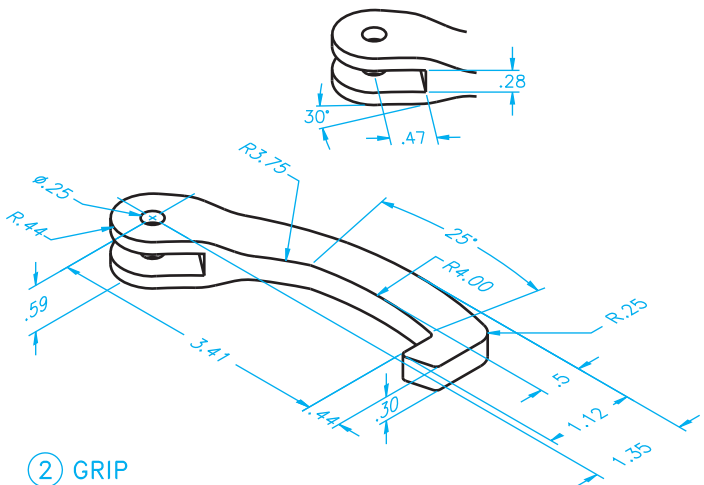
LOCK NUT WRENCH BILL OF MATERIALS		
ITEM	QTY	DESCRIPTION
1	1	GRIP
2	1	STEEL RIVET, $\varnothing.25$ X .625 LONG
3	1	MAIN BODY



LOCK NUT WRENCH

NOTE:  
1. RIVET PER STANDARD SHOP PRACTICE.

① WRENCH BODY  
MATL: CAST ALUMINUM



② GRIP  
MATL: CAST ALUMINUM  
UNSPECIFIED FILLETS & ROUNDS: R.06

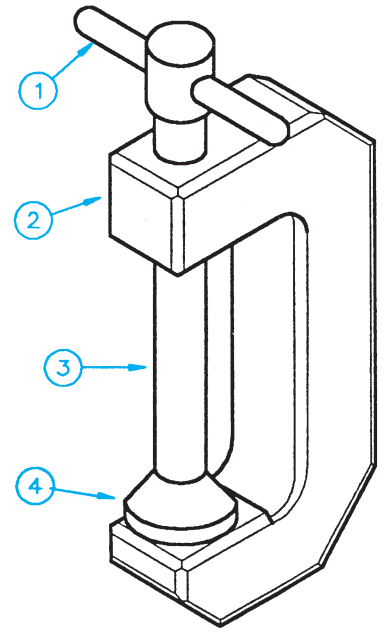
© Cengage Learning 2012

**PROBLEM 15.5 Working drawing (metric)**

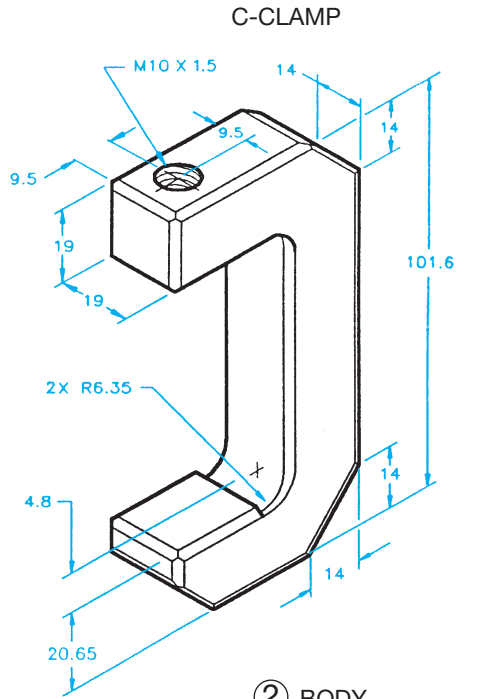
Assembly Name: C-clamp

SPECIFIC INSTRUCTIONS: Prepare a complete set of working drawings with all of the detail drawings on one sheet and the assembly drawings and parts list on another sheet. Use multiview projection for view layout.

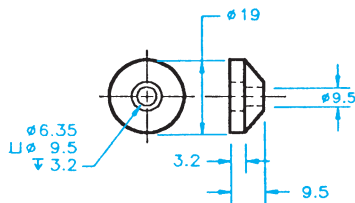
PARTS LIST			
ITEM	QTY	NAME	MATERIAL
1	1	PIN	CRMS
2	1	BODY	SAE 4320
3	1	SCREW	SAE 4320
4	1	SWIVEL	SAE 1020



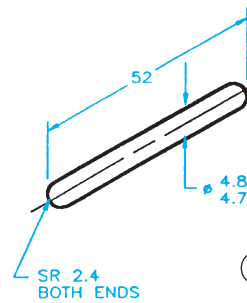
C-CLAMP



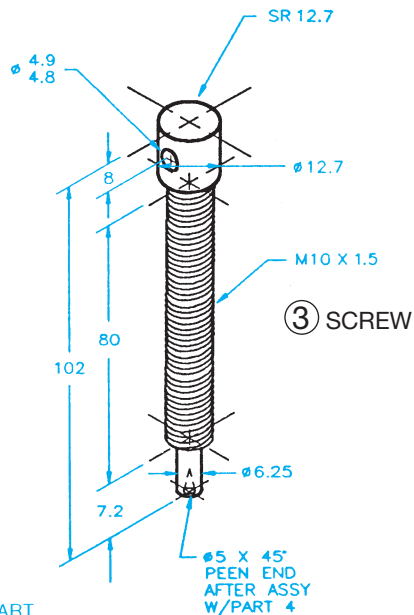
② BODY  
CHAMFER ALL CORNER 45° X 1.6



④ SWIVEL



① PIN



③ SCREW

FINISH EACH PART ALL OVER 0.8 μM

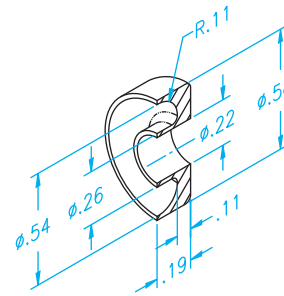
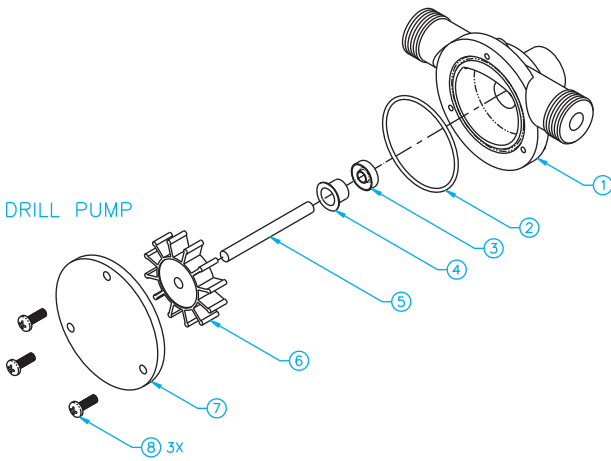
© Cengage Learning 2012

PROBLEM 15.6 Working drawing (in.)

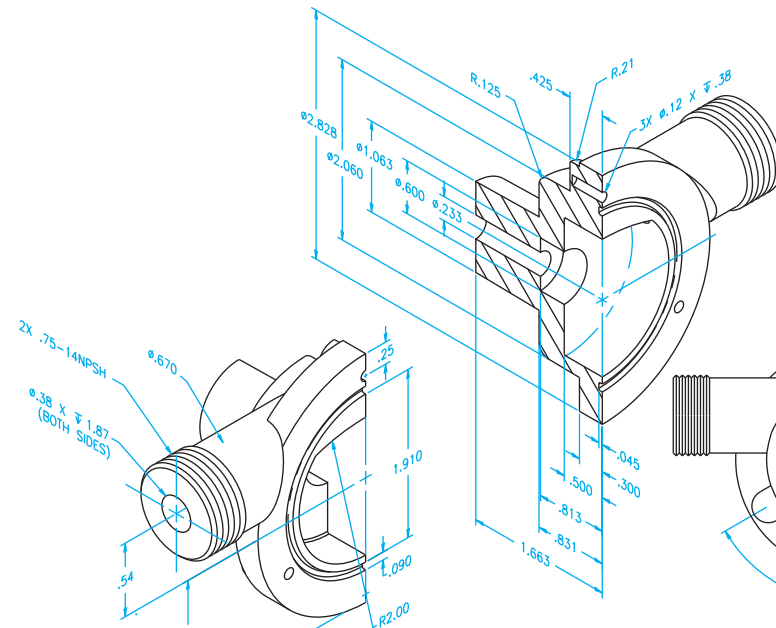
Assembly Name: Drill Pump

SPECIFIC INSTRUCTIONS: Prepare a complete set of working drawings with one detail drawing per sheet and the assembly drawing and bill of materials on another sheet. Use multiview projection for view layout.

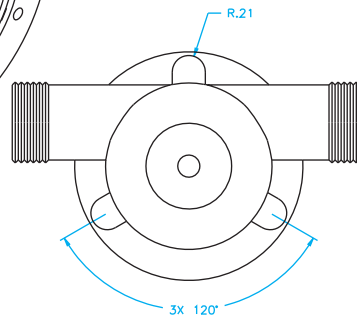
DRILL PUMP BILL OF MATERIALS		
ITEM	QTY	DESCRIPTION
1	1	PUMP HOUSING
2	1	.070 O-RING, Ø2.00
3	1	SEAL
4	1	PLASTIC BUSHING
5	1	SHAFT
6	1	PADDLE WHEEL
7	1	COVER
8	3	1/8" X 5/8" LONG PAN HEAD SCREW, THREAD CUTTING



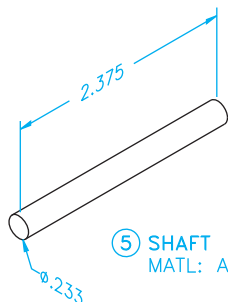
③ SEAL  
MATL: POLYURETHANE  
UNSPECIFIED FILLETS & ROUNDS: R.03



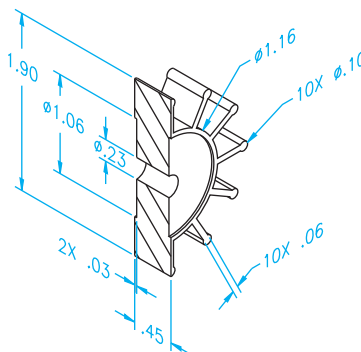
① PUMP HOUSING  
MATL: POLYAMIDE  
UNSPECIFIED FILLETS & ROUNDS: R.02



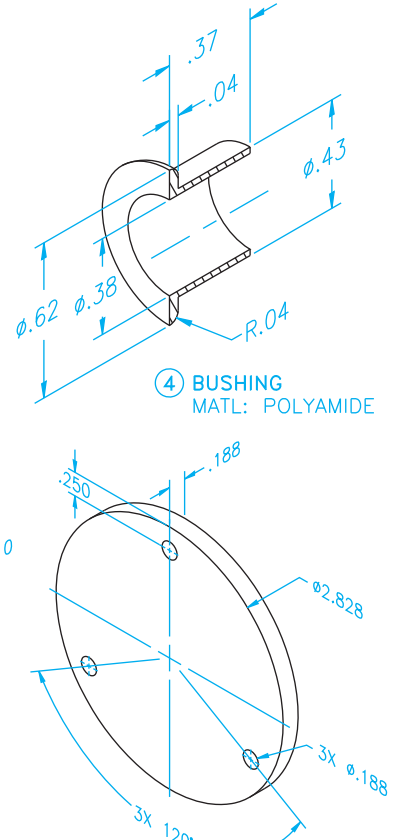
④ BUSHING  
MATL: POLYAMIDE



⑤ SHAFT  
MATL: AISI 302



⑥ PADDLE WHEEL  
MATL: POLYURETHANE



⑦ COVER  
MATL: POLYAMIDE

**PROBLEM 15.7 Working drawing (in.)**

Assembly Name: Mill Work Stop

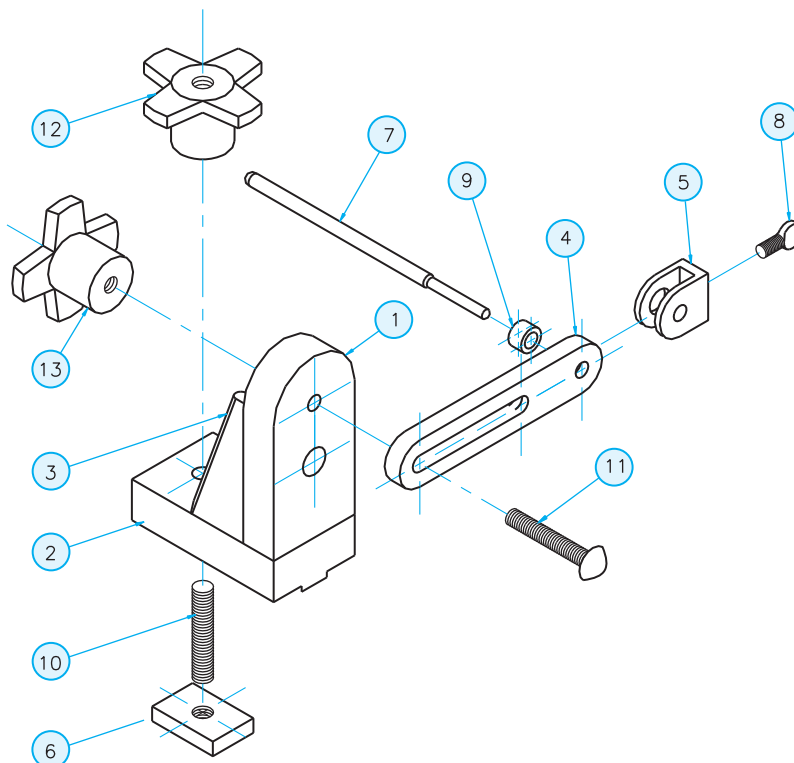
**SPECIFIC INSTRUCTIONS:** This problem has basic applications. However, there is a welding symbol involved in the assembly. You should study welding processes and representations covered in Chapter 18 before completing this problem.

Prepare a complete set of working drawings with one detail drawing per sheet and the assembly drawing with parts list on one sheet. Notice that part number 10, TEE

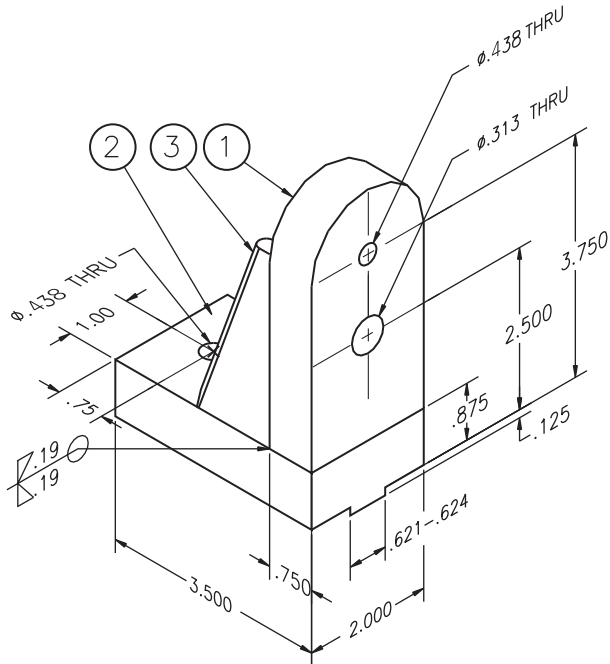
STUD, is cut from standard 3/8-16UNC ALL THREAD. Parts 12 and 13, BLANK KNOBS, are purchased as knobs without the threads machined. You will draw the knobs as a representation of the purchase part and give the thread note as identified in the parts list. The actual dimensions of the knob to be purchased are not important. However, accurate specifications for the threads to be machined into the purchase part *are* important.

*Note:* Some design is required throughout the completion of the project.

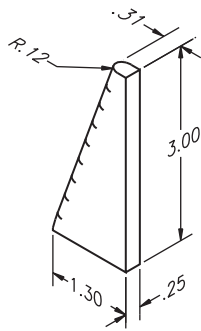
PARTS LIST				
ITEM	QTY	NAME	DESCRIPTION	MATERIAL
1	1	VERTICAL MEMBER	3/4 × 2 × 4	SAE 6061
2	1	BASE MEMBER	1 × 2 × 3.5	SAE 6061
3	2	RIB	1/4 PLATE	SAE 6061
4	1	ARM	3/8 × 1 × 5-1/2	SAE 1018
5	1	CLAMP	1/2 × 1 × 1-5/16	SAE 1018
6	1	TEE PLATE DRILL AND TAP AT CENTER FOR 5/16-18UNC-2 THREAD THRU	5/16 × 1 × 1-1/4	SAE 1018
7	1	STOP ROD	Ø5/16 × 6	SAE 303 SS
8	1	WING NUT	1/4-28 × 1/2	
9	1	BUSHING	Ø1/2 × .31	SAE 1018
10	1	TEE STUD	3/8-16 × 2 LG ALL THREAD	
11	1	CARRIAGE BOLT	5/16-18UNC-2	
12	21	BLANK KNOB	VLIER HK-3 (DRILL AND TAP FOR 3/8-16UNC-2B)	
13	1	BLANK KNOB	VLIER HK-3 (DRILL AND TAP FOR 5/16-18UNC-2B)	



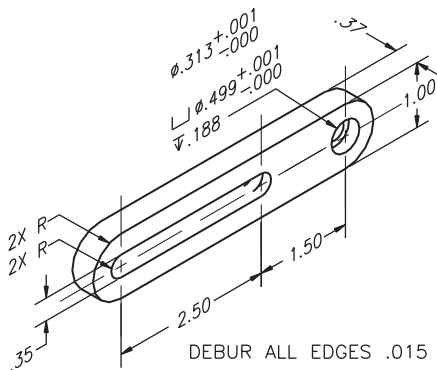
PROBLEM 15.7 (Continued)



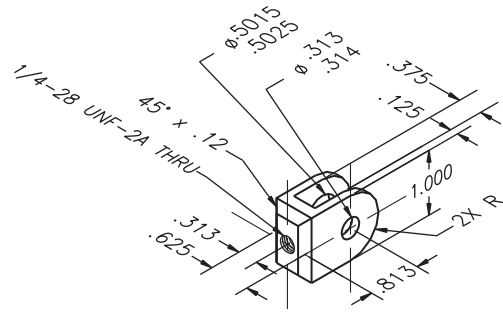
DEBUR ALL EDGES .020  
**BODY ASSEMBLY WELDMENT**  
 FINISH: COLOR ANODIZED



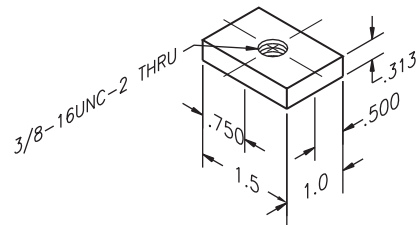
③ RIB



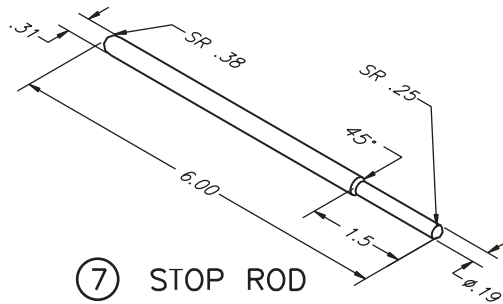
④ ARM  
 FINISH: C HARDEN .005/.010  
 BLACK OXIDE



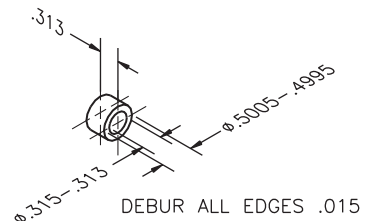
DEBUR ALL EDGES .015  
 EXCEPT 0.313-.314  
 ⑤ CLAMP  
 FINISH: C HARDEN .005/.010  
 BLACK OXIDE



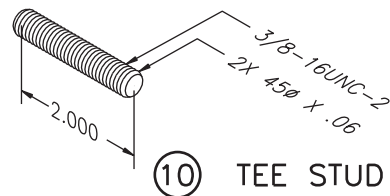
⑥ TEE PLATE



⑦ STOP ROD  
 FINISH: POLISH



⑨ BUSHING  
 FINISH: C HARDEN .005/.010  
 BLACK OXIDE



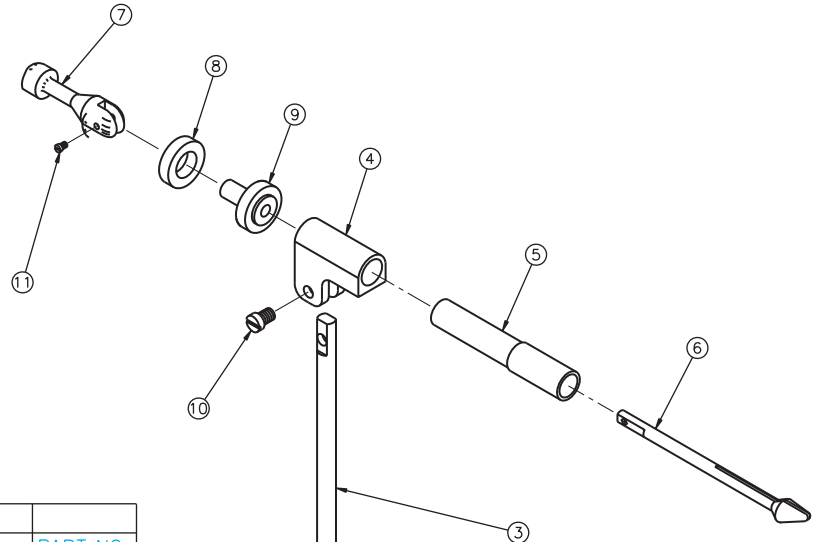
⑩ TEE STUD

**PROBLEM 15.8 Working drawing (in.)**

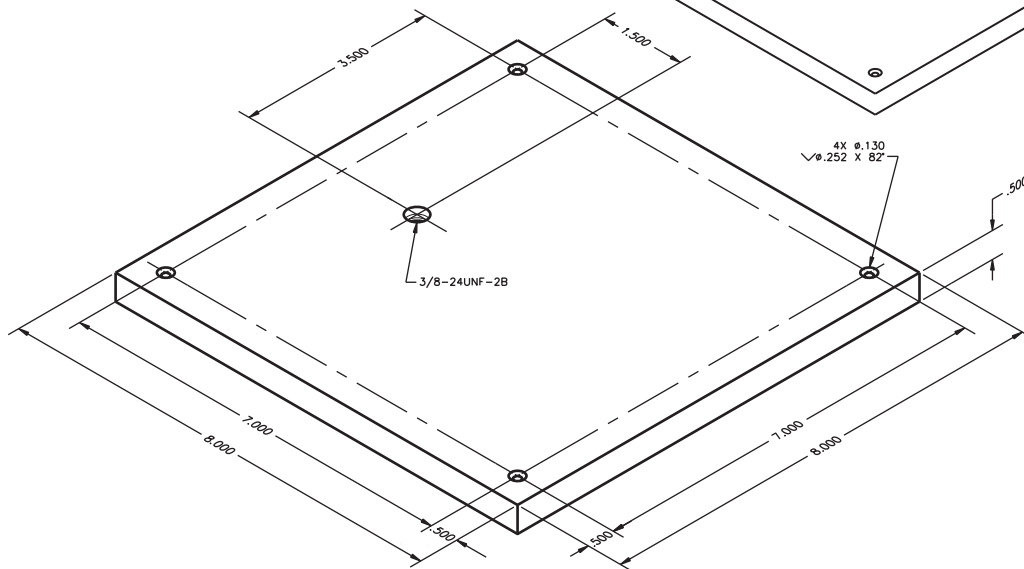
Assembly Name: Fly Tying Vise

SPECIFIC INSTRUCTIONS: Prepare a complete set of working drawings with one detail drawing per sheet and the

assembly and parts list on another sheet. When preparing the assembly drawing, use separate balloons for each part in each view or use only one balloon in the view that most clearly identifies the part. *Problem Courtesy of David P. Madsen and John Melloy*

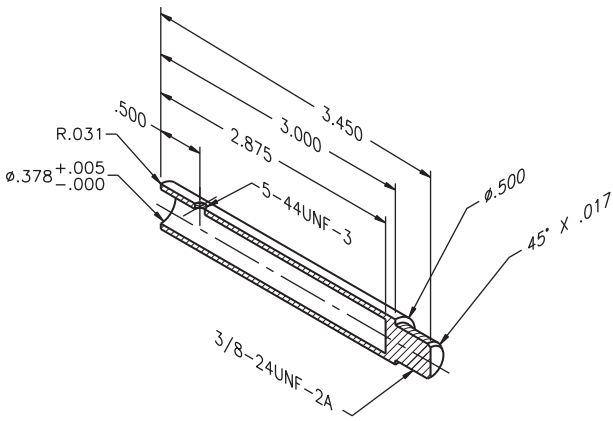


PARTS LIST			
KEY	QTY	DESCRIPTION	PART NO.
1	1	PEDESTAL BASE	1DT1001
2	1	PEDESTAL HOUSING	1DT1002
3	1	PEDESTAL	1DT1003
4	1	MAIN HOUSING	1DT1004
5	1	ROTATING HOUSING	1DT1005
6	1	JAW SHAFT	1DT1006
7	1	HANDLE CAM	1DT1007
8	1	ADJUSTMENT KNOB	1DT1008
9	1	NUT	1DT1009
10	1	1/4-28UNF-3 X .075 LG HEX SOC HD CAP SC	--
11	1	#5-44UNF-3 X .50 LG HEX SOC HD SET SC	--
12	1	#5-44UNF-3 X .075 LG HEX SOC HD SET SC	--

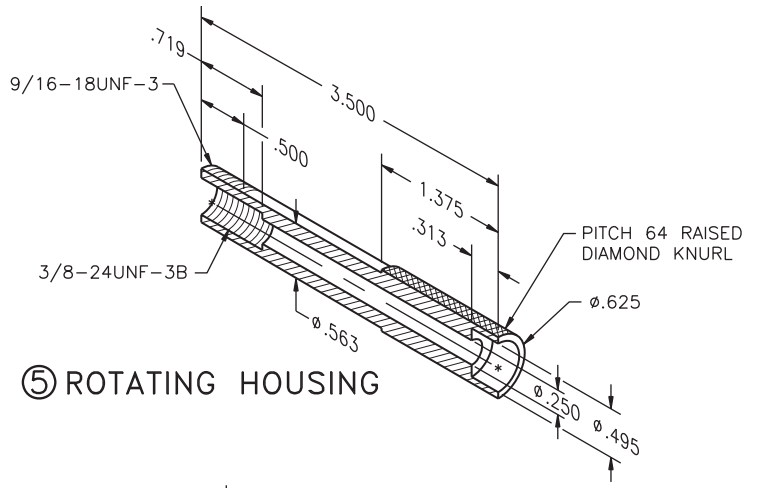


① PEDESTAL BASE

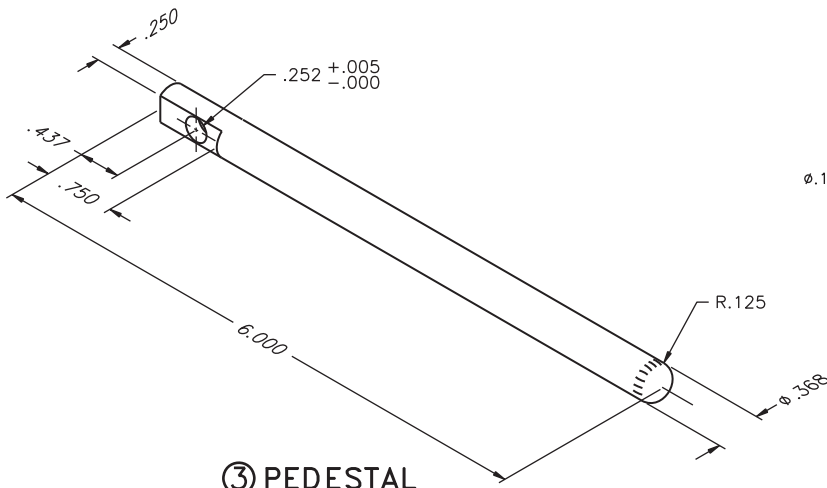
PROBLEM 15.8 (Continued)



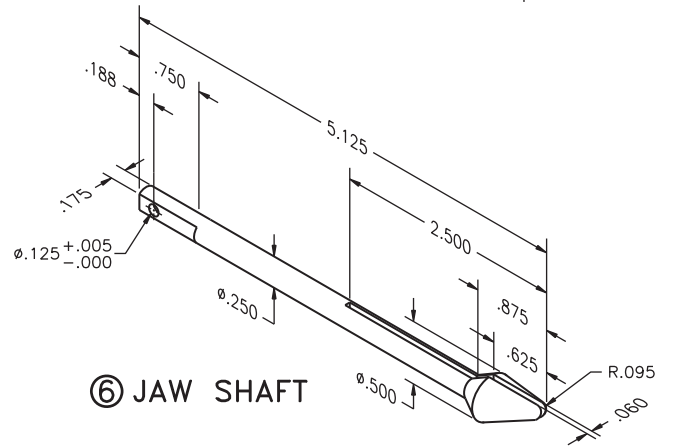
② PEDESTAL HOUSING



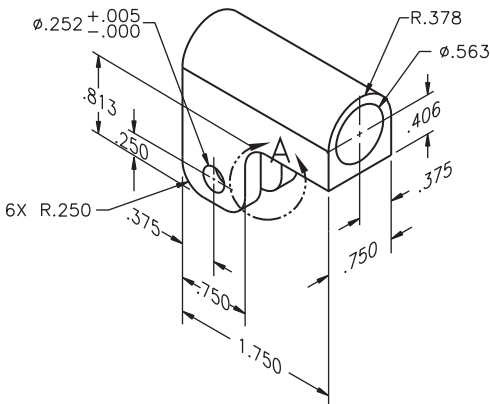
⑤ ROTATING HOUSING



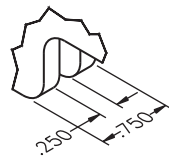
③ PEDESTAL



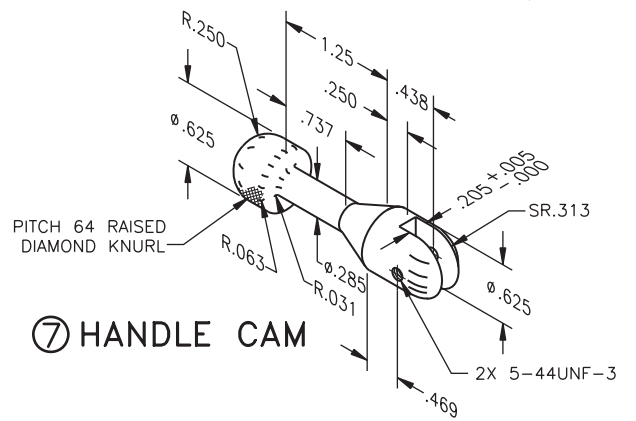
⑥ JAW SHAFT



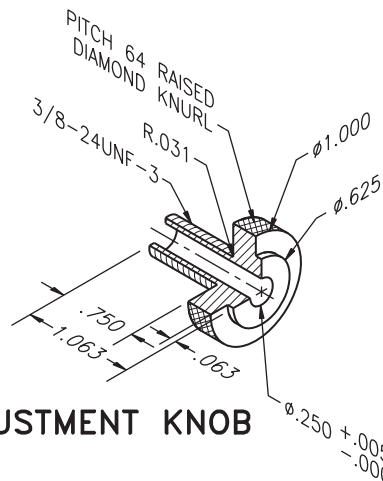
④ MAIN HOUSING



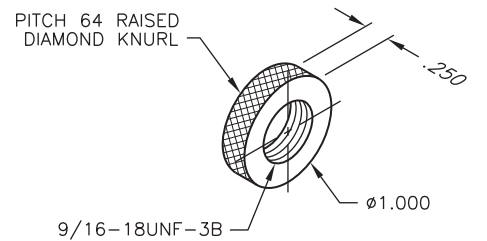
VIEW A



⑦ HANDLE CAM



⑧ ADJUSTMENT KNOB



⑨ NUT

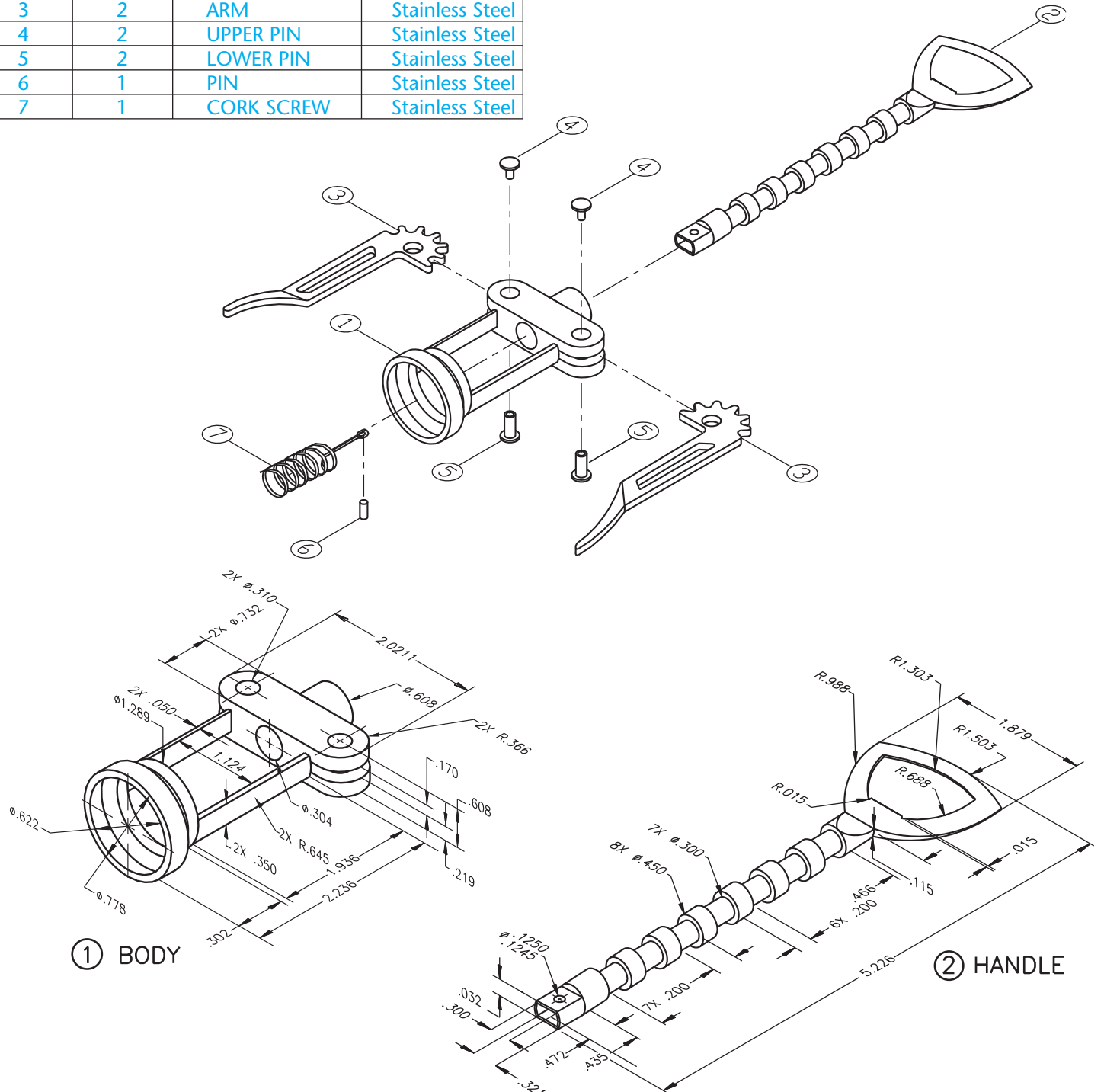
**PROBLEM 15.9 Working drawing (in.)**

Assembly Name: Cork Screw

**SPECIFIC INSTRUCTIONS:** Prepare a complete set of working drawings with one detail drawing per sheet and the assembly and parts list on another sheet. When preparing the assembly drawing, use separate balloons for each part in each view or use only one balloon in the view that most

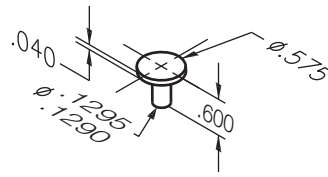
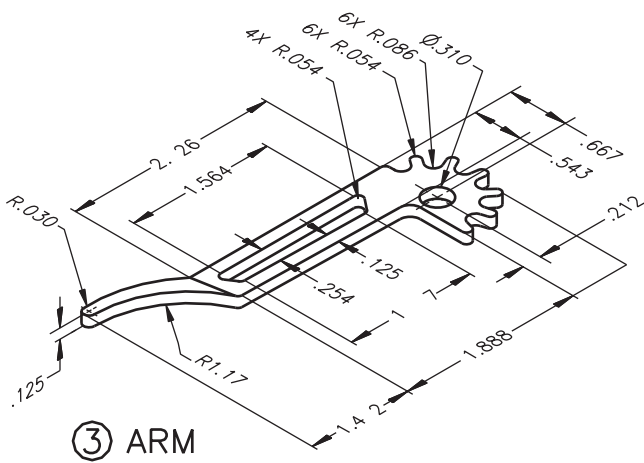
clearly identifies the part. Establish tolerances between mating parts. Determine the dimensions for the Pin, Part 6 and create needed detail or purchase part specifications. Errors are likely in this problem. Identify and correct errors as discussed in the general problem instructions in this chapter. Verify dimensions during assembly. Establish tolerances between mating parts.

PARTS LIST							
ITEM	QTY	NAME	MATERIAL				
1	1	BODY	Stainless Steel				
2	1	HANDLE	Stainless Steel				
3	2	ARM	Stainless Steel				
4	2	UPPER PIN	Stainless Steel				
5	2	LOWER PIN	Stainless Steel				
6	1	PIN	Stainless Steel	7	1	CORK SCREW	Stainless Steel
7	1	CORK SCREW	Stainless Steel				

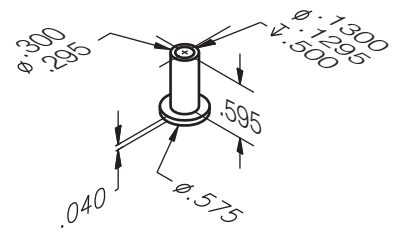




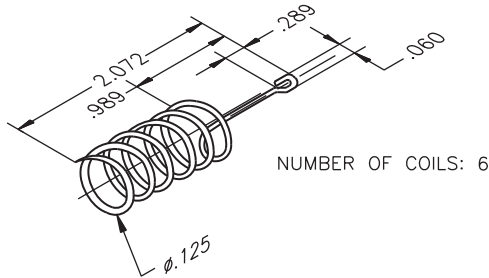
PROBLEM 15.9 (Continued)



④ UPPER PIN



⑤ LOWER PIN



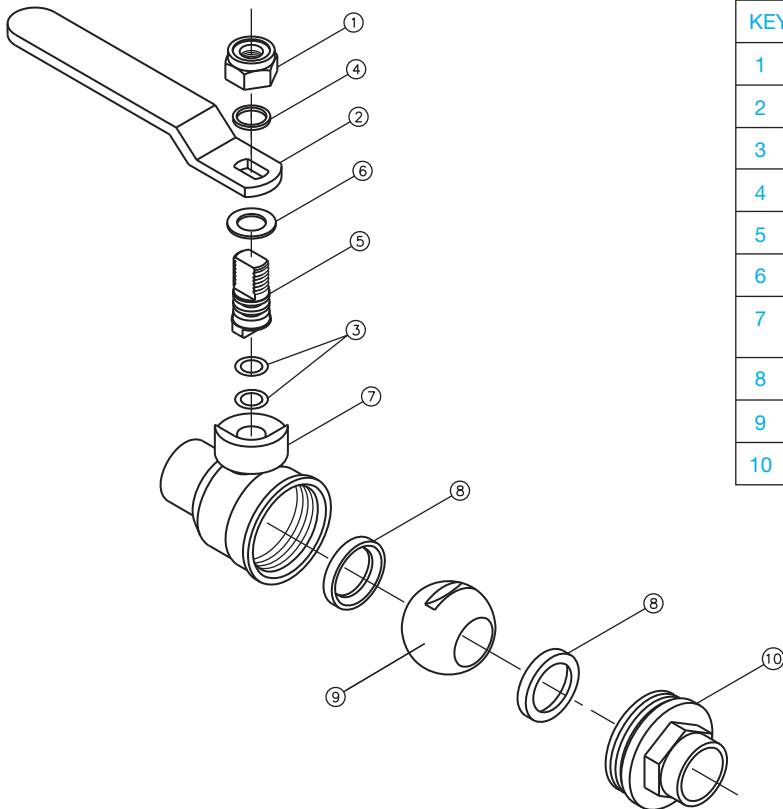
⑦ CORK SCREW

PROBLEM 15.10 Working drawing (in.)

Assembly Name: Ball Valve

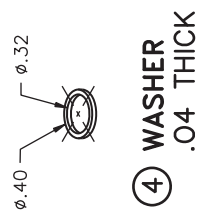
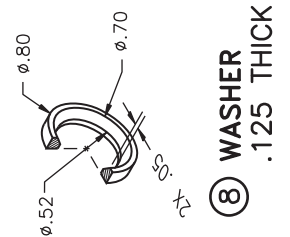
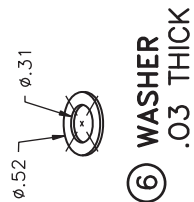
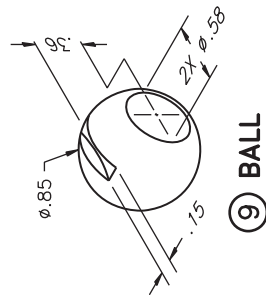
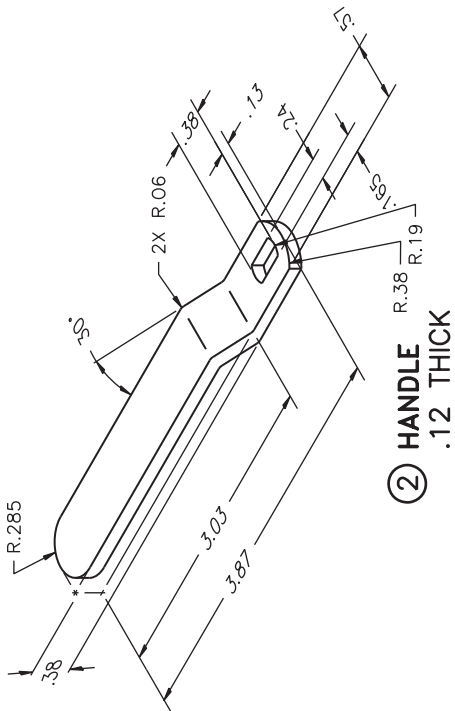
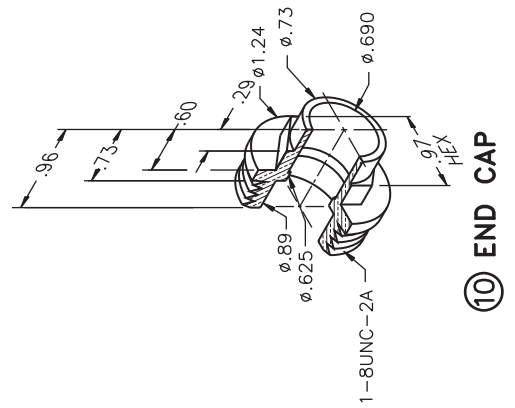
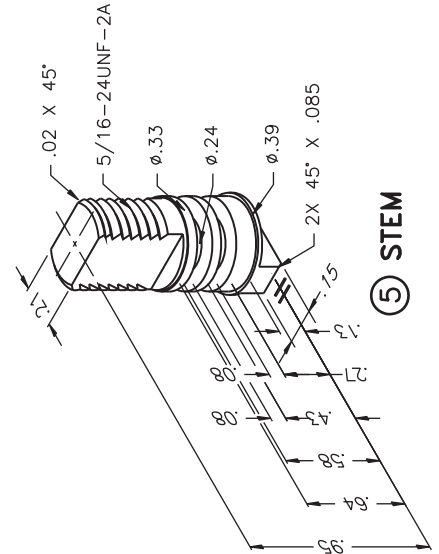
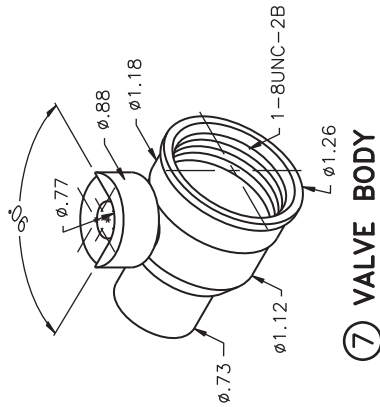
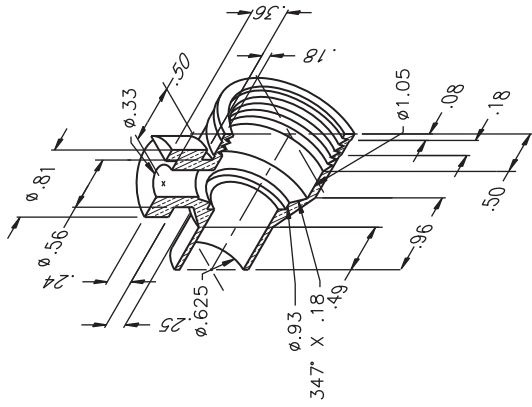
SPECIFIC INSTRUCTIONS: Prepare a complete set of working drawings with one detail drawing per sheet and the assembly and parts list on another sheet. When preparing the assembly drawing, use separate balloons for each part

in each view or use only one balloon in the view that most clearly identifies the part. This is a prototype project. Errors are likely in this problem. Identify and correct errors as discussed in the general problem instructions in this chapter. Verify dimensions during assembly. Establish tolerances between mating parts.



PARTS LIST				
KEY	QTY	NAME	MATERIAL	PART NO.
1	1	NUT	5/16-24UNF-2	5DT1001
2	1	HANDLE	STAINLESS STEEL	1DT1002
3	2	O-RING	PARKER #2-008	5DT1003
4	1	WASHER	PLASTIC	1DT1004
5	1	STEM	STAINLESS STEEL	1DT1005
6	1	WASHER	PLASTIC	1DT1006
7	1	VALVE BODY	BRASS	1DT1007
8	2	WASHER	PLASTIC	1DT1008
9	1	BALL	STAINLESS STEEL	1DT1009
10	1	END CAP	BRASS	1DT1010

PROBLEM 15.10 (Continued)

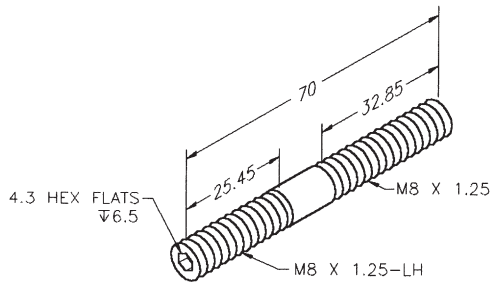
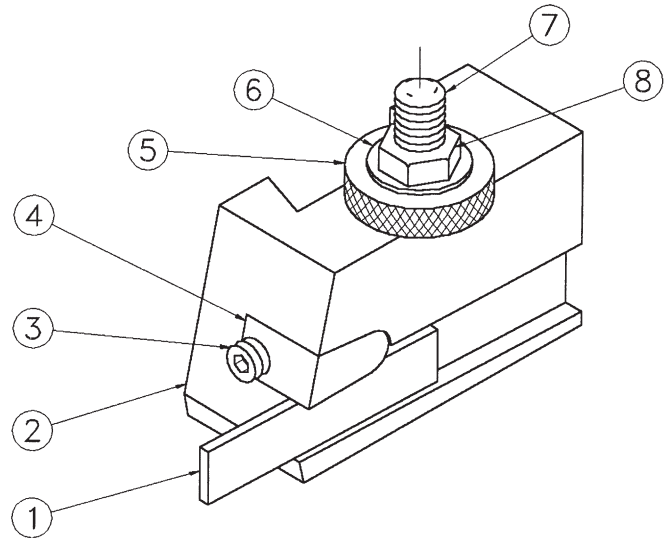


PROBLEM 15.11 Working drawing (metric)

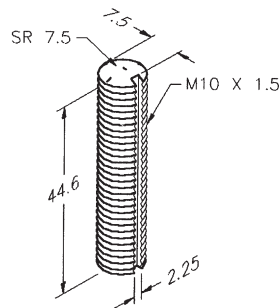
Assembly Name: Tool Holder

SPECIFIC INSTRUCTIONS: Prepare a complete set of working drawings with one detail drawing per sheet and the assembly and parts list on another sheet. When preparing the assembly drawing, use separate balloons for each part in each view or use only one balloon in the view that most clearly identifies the part.

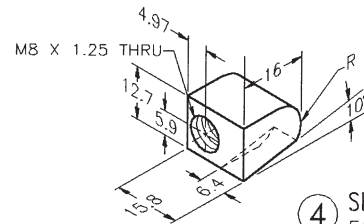
PARTS LIST			
ITEM	QTY	NAME	MATERIAL
1	1	PARTING TOOL, 3/32 IN × 1/2 IN PURCHASE PART	TOOL STEEL
2	1	TOOL HOLDER BODY	06 STEEL
3	1	ADJUSTMENT SCREW	SAE 1035 STEEL
4	1	SHIM	SAE 4320 STEEL
5	1	KNURL NUT	SAE 3130 STEEL
6	1	WASHER	SAE 1060 STEEL
7	1	STUD	SAE 1035 STEEL
8	1	M 10 × 1.5 HEX NUT PURCHASE PART	



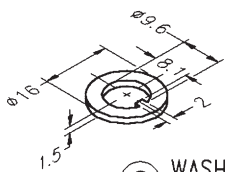
③ ADJUSTMENT SCREW  
FAO 3.2 μm



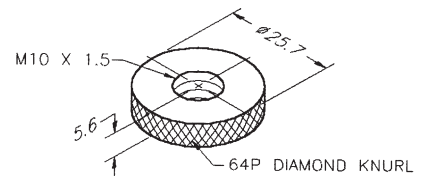
⑦ STUD  
FAO 3.2 μm



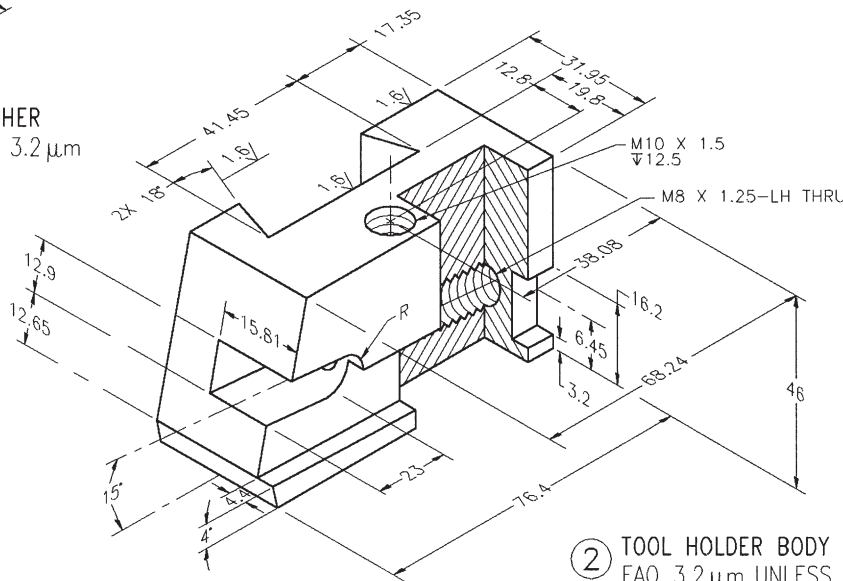
④ SHIM  
FAO 3.2 μm



⑥ WASHER  
FAO 3.2 μm



⑤ KNURL NUT  
FAO 3.2 μm



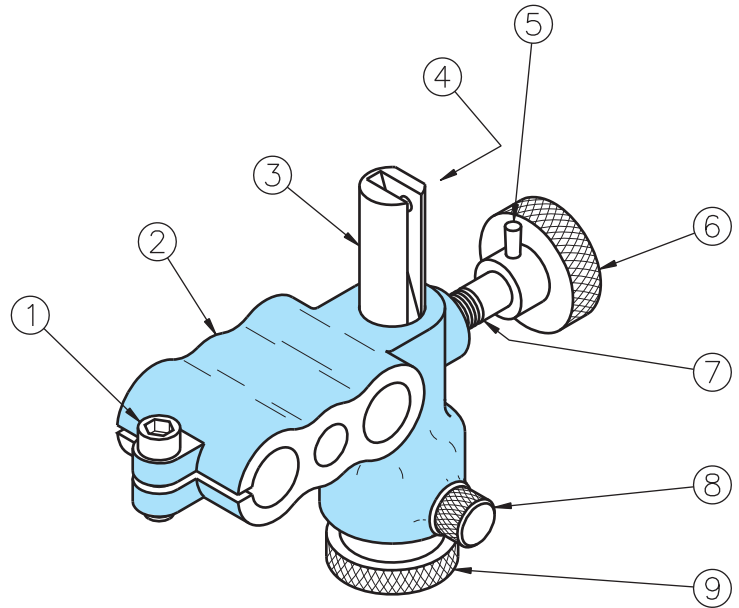
② TOOL HOLDER BODY  
FAO 3.2 μm UNLESS OTHERWISE SPECIFIED

**PROBLEM 15.12 Working drawing (in.)**

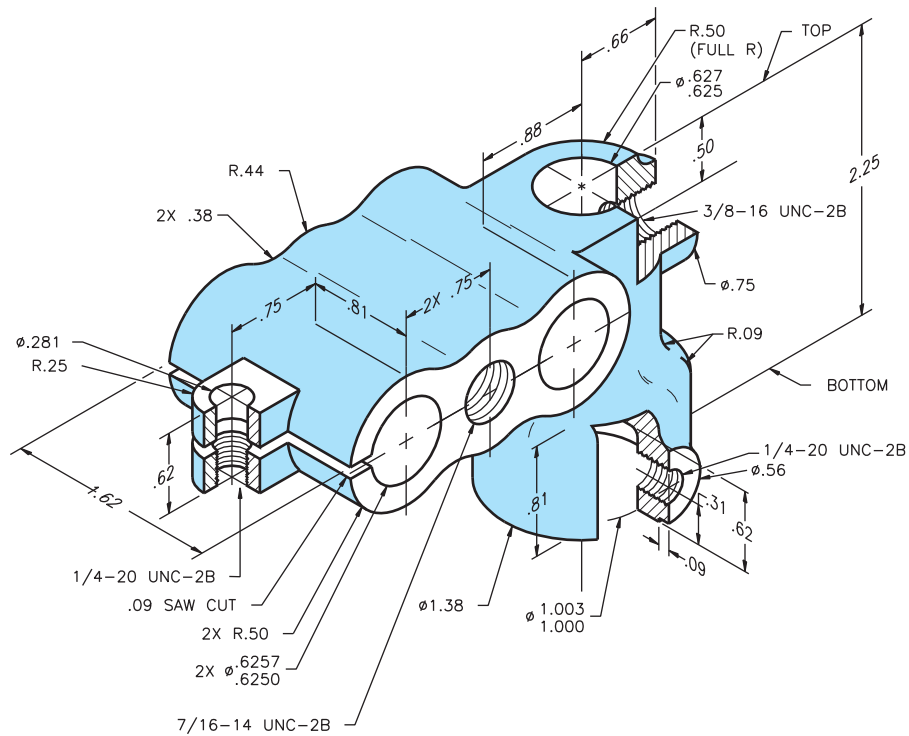
Assembly Name: Adjustable Attachment

SPECIFIC INSTRUCTIONS: Prepare a complete set of working drawings with detail drawings of individual parts combined on one or more sheets, depending on the size of sheet selected. The assembly drawing and parts list is combined on one sheet.

PARTS LIST				
ITEM	QTY	NAME	DESCRIPTION	MATERIAL
1	1	CAP SCREW	.25-20UNC-2 × .75 HEX SOC HEAD	STL
2	1	FRAME		SAE 4340
3	1	ADJUSTING SCREW		SAE1045
4	1	SET SCREW	8-32UNC-2 HEX SOC FLAT POINT	STL
5	1	TAPER PIN	0 × .625	STL
6	1	KNURL KNOB		SAE 1024
7	1	CLAMP SCREW		SAE 2330
8	1	PILOT SCREW		SAE 2330
9	1	ADJUSTING NUT		SAE 3130

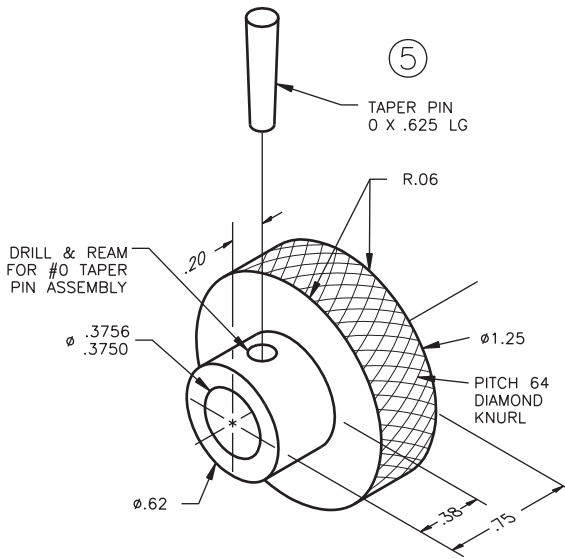


ADJUSTABLE ATTACHMENT

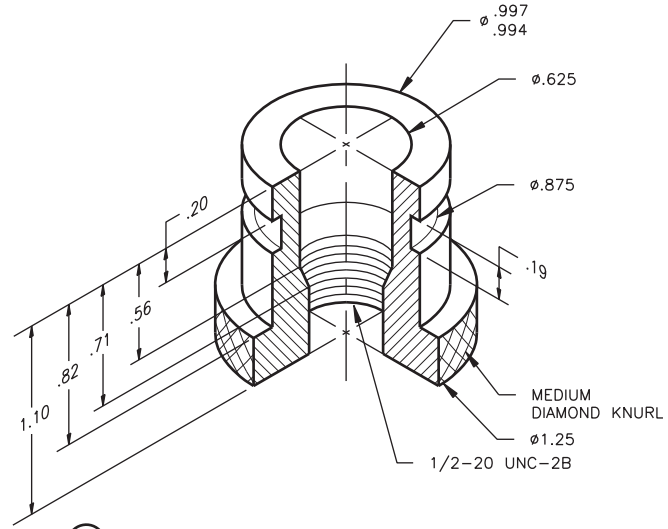


- ② **FRAME**  
SAE 4340  
REMOVE ALL BURRS & SHARP EDGES  
FAO  
FILLETS AND ROUNDS R.125

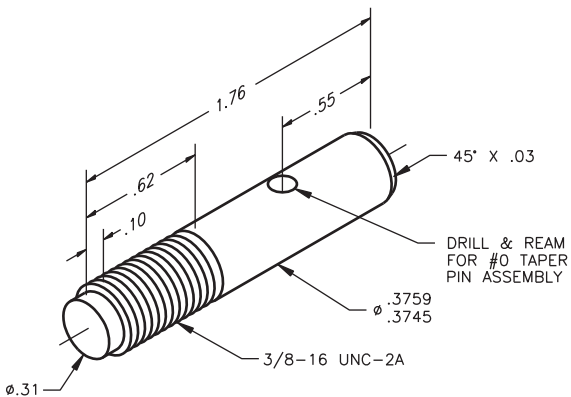
PROBLEM 15.12 (Continued)



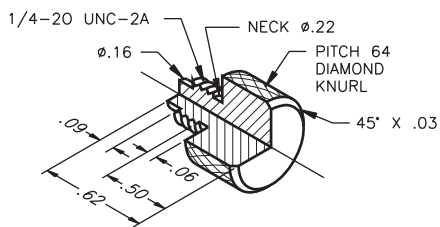
⑥ **KNURL KNOB**  
SAE 1024  
REMOVE ALL BURRS & SHARP EDGES  
FAO



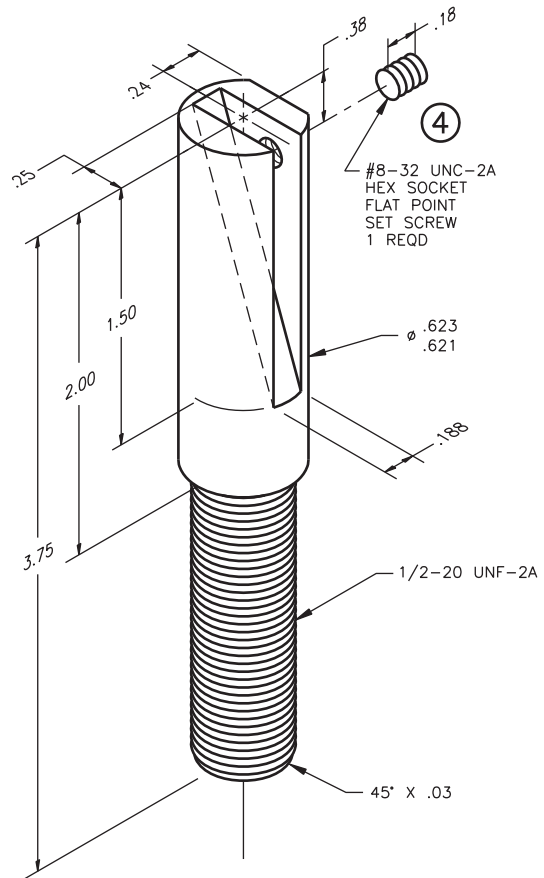
⑨ **ADJUSTING NUT**  
SAE 3130  
REMOVE ALL BURRS & SHARP EDGES



⑦ **CLAMP SCREW**  
SAE 2330  
REMOVE ALL BURRS & SHARP EDGES



⑧ **PILOT SCREW**  
SAE 2330  
REMOVE ALL BURRS & SHARP EDGES  
FAO

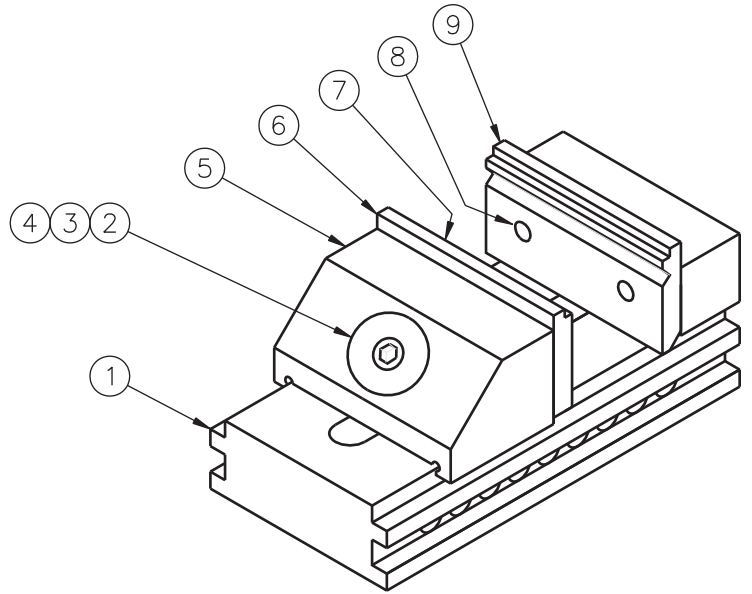


③ **ADJUSTING SCREW**  
SAE 1045  
REMOVE ALL BURRS & SHARP EDGES  
FAO

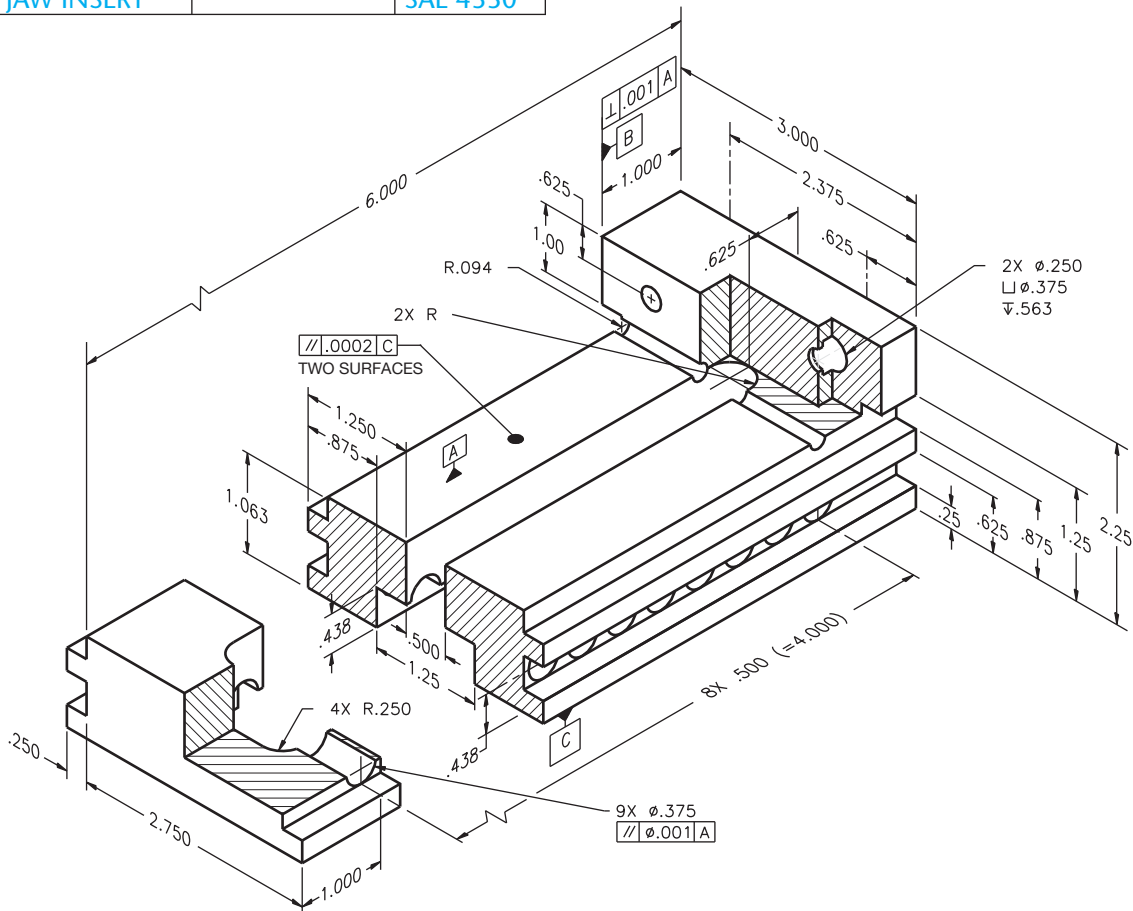
**PROBLEM 15.13 Working drawing (in.)**

Assembly Name: Precision Vise

SPECIFIC INSTRUCTIONS: Prepare a complete set of working drawings with one detail drawing per sheet and the assembly drawing and bill of materials on another sheet. Use multiview projection for view layout.

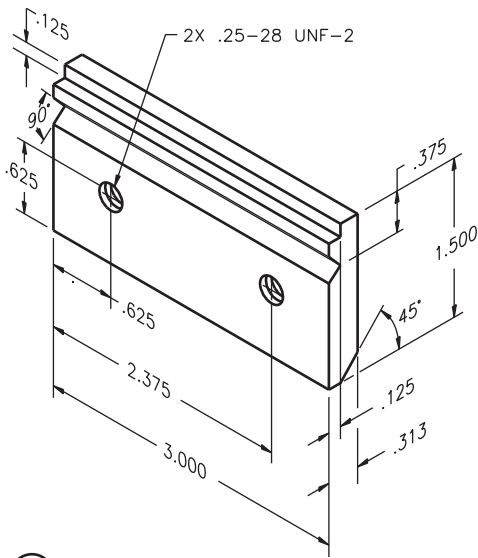


PARTS LIST				
ITEM	QTY	NAME	DESCRIPTION	MATERIAL
1	1	BASE		SAE 1040
2	1	BALL WASHER		SAE 1040
3	1	NUT		SAE 1040
4	1	CAP SCREW	5/16-24NF × 1 1/2 HEX SOCKET HEAD	STL
5	1	JAW		SAE 1040
6	1	JAW INSERT		SAE 4330
7	2	MACH SCREW	1/4-28NF × 1/2 FLAT HD	STL
8	2	CAP SCREW	1/4-28NF × 3/4 HEX SOCKET HEAD	STL
9	1	JAW INSERT		SAE 4330

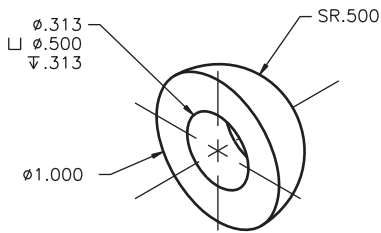


1 BASE  
FAO 32 μIN

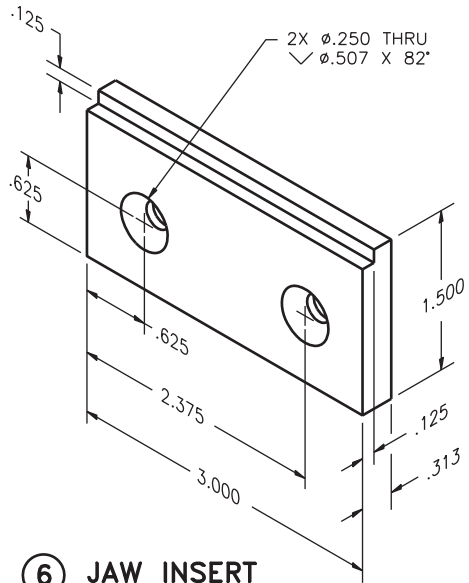
PROBLEM 15.13 (Continued)



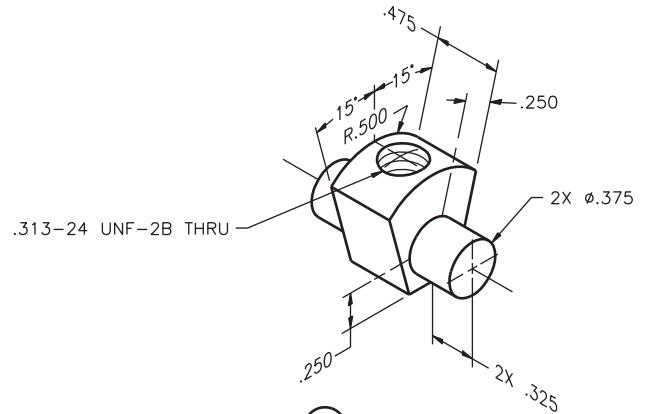
9 JAW INSERT  
FAO 32 μIN



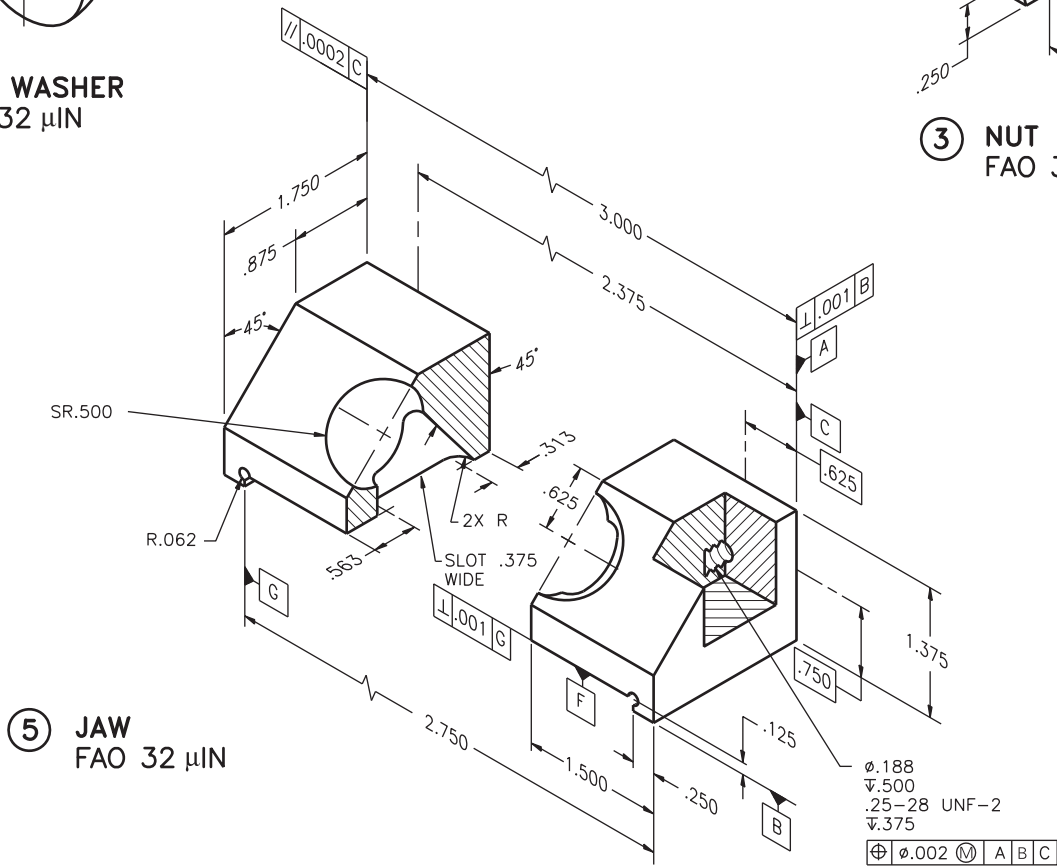
2 BALL WASHER  
FAO 32 μIN



6 JAW INSERT  
FAO 32 μIN



3 NUT  
FAO 32 μIN



5 JAW  
FAO 32 μIN

$\text{Ø} .002$   $\text{M}$  A B C  
 $\text{Ø} .188$   
 $\text{▽} .500$   
 $.25-28 \text{ UNF-2}$   
 $\text{▽} .375$

© Cengage Learning 2012

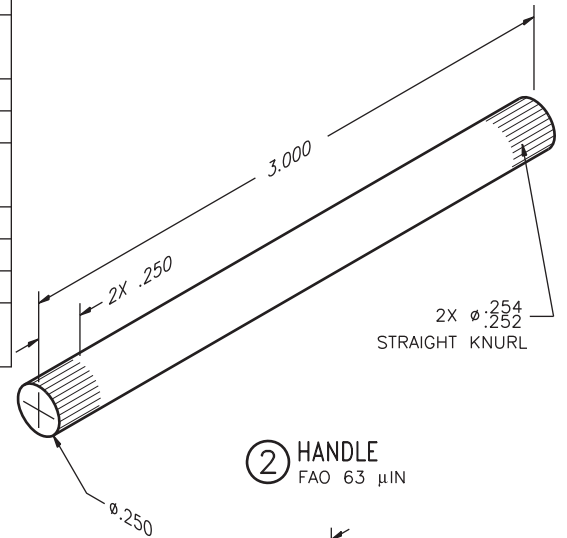
**PROBLEM 15.14 Working drawing (in.)**

Assembly Name: Machine Vise

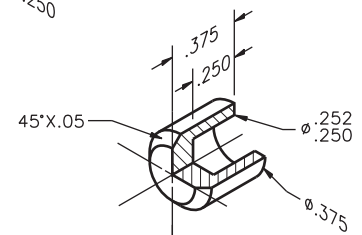
SPECIFIC INSTRUCTIONS: When preparing the assembly drawings, use separate balloons for each part in each view

or use only one balloon in the view that most clearly identifies the part. Prepare a complete set of working drawings with one detail drawing per sheet and the assembly drawing and bill of materials on another sheet. Use multiview projection for view layout.

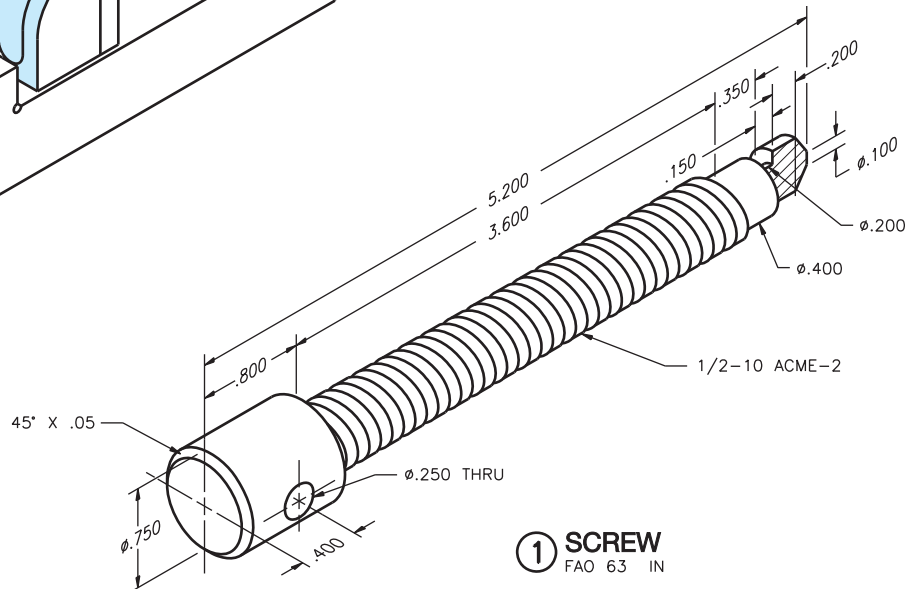
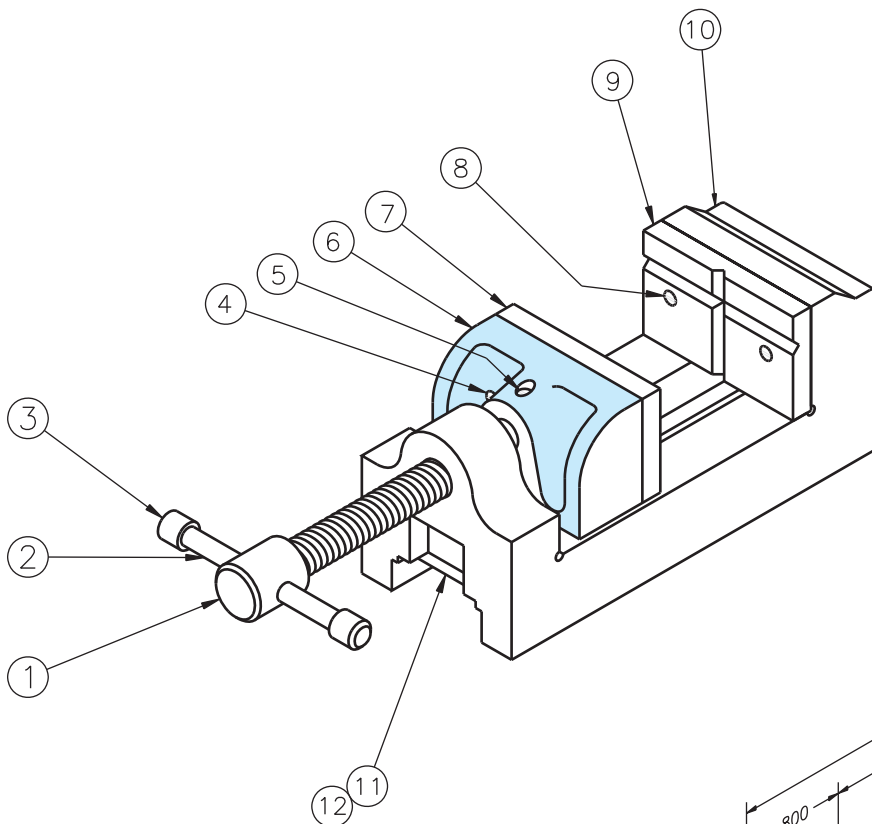
PARTS LIST				
ITEM	QTY	NAME	DESCRIPTION	MATERIAL
1	1	SCREW		SAE 4320
2	1	HANDLE		MS
3	2	CAP		MS
4	2	MACHINE SCREW	(10).190-32UNF-2 X .625 SLOT FIL HD	STL
5	1	SET SCREW	1/4-20UNC-2 X .250 FULL DOG POINT	STL
6	1	MOVABLE JAW		SAE 1020
7	1	MOVABLE JAW PLATE		SAE 4320
8	2	MACHINE SCREW	(10).190-32UNF-2 X .875 SLOT FIL HD	STL
9	1	FIXED JAW PLATE		SAE 4320
10	1	BODY		SAE 4320
11	1	GUIDE		SAE 1020
12	2	MACHINE SCREW	1/4-20UNC-2 X .500 SLOT FIL HD	STL



**2** HANDLE  
FAO 63 μIN



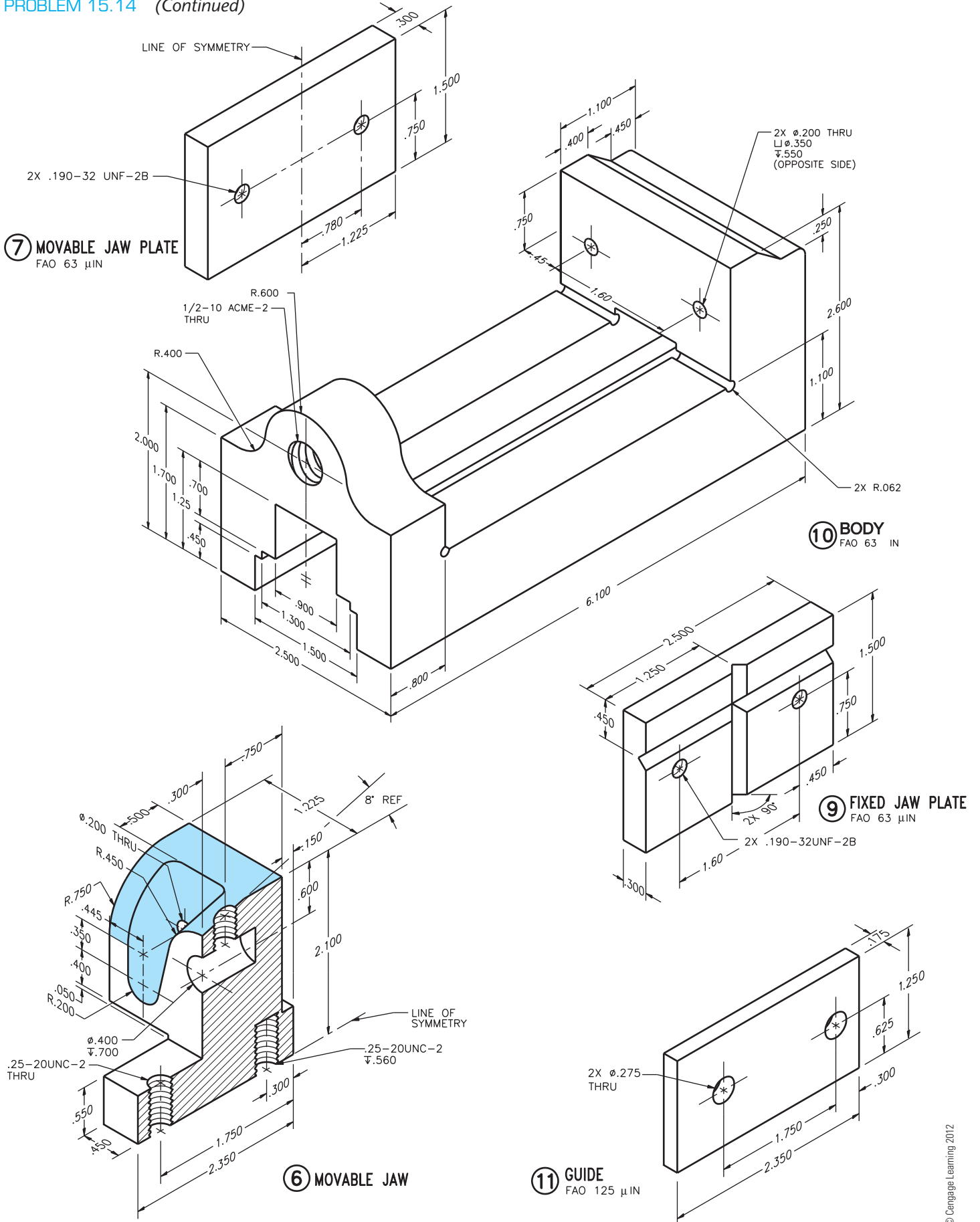
**3** CAP  
FAO 63 μIN



**1** SCREW  
FAO 63 μIN



PROBLEM 15.14 (Continued)



**PROBLEM 15.15 Working drawing (in.)**

Assembly Name: Arbor Press

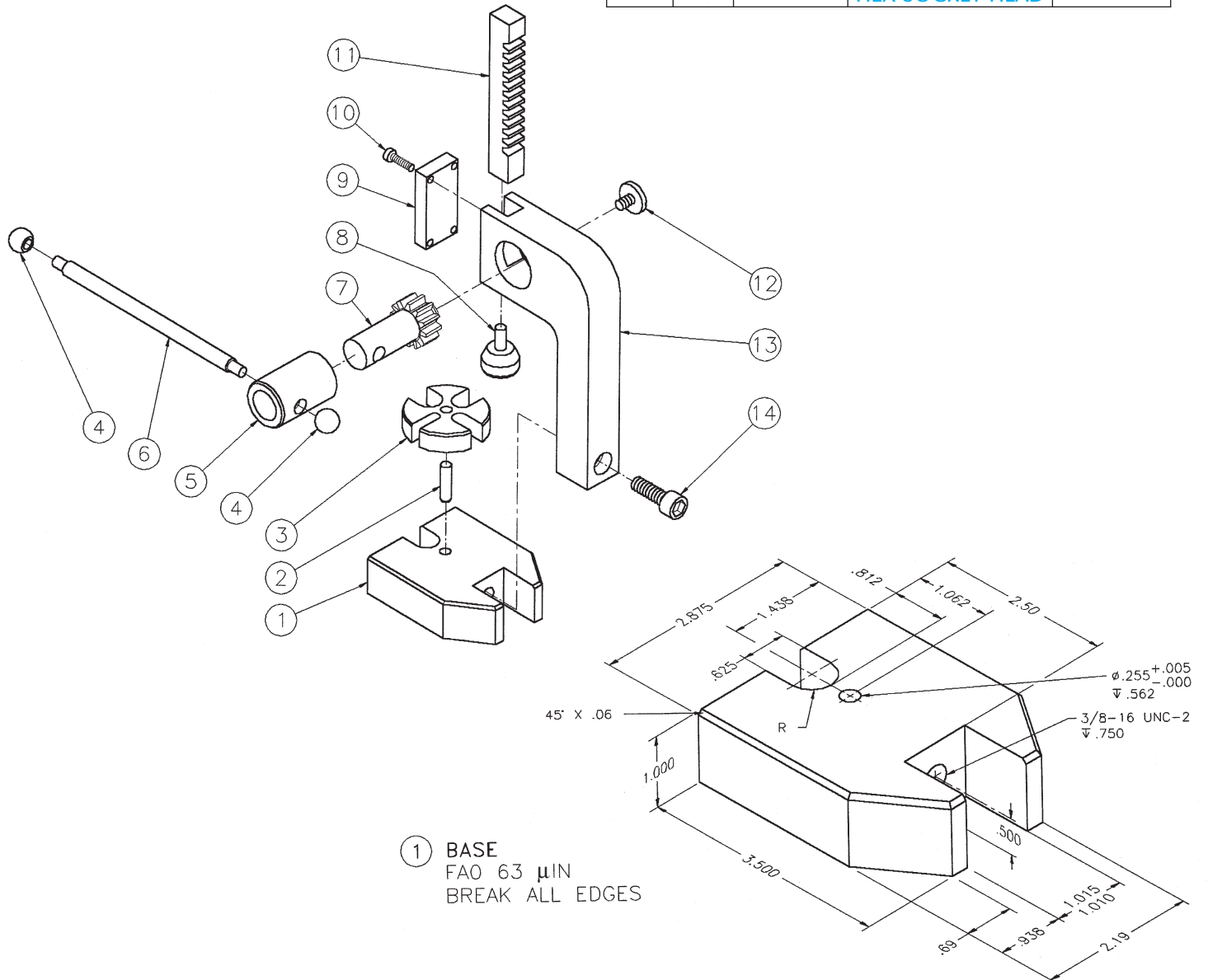
SPECIFIC INSTRUCTIONS: This problem is generally basic, but it also contains challenging applications that include gears. You should study gears and related drafting practices

covered in Chapter 16 before completing this problem. Prepare a complete set of working drawings with one detail drawing per sheet and the assembly drawing and bill of materials on another sheet. Use multiview projection for view layout.

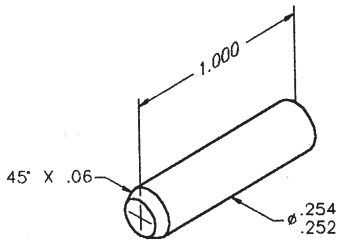
**PARTS LIST**

ITEM	QTY	NAME	DESCRIPTION	MATERIAL
1	1	BASE		SAE 1020
2	1	TABLE PIN		SAE 1020
3	1	TABLE		SAE 1020
4	2	BALL END		SAE 1020
5	1	SLEEVE		SAE 1020
6	1	HANDLE		SAE 1020
7	1	GEAR		SAE 4320
8	1	RACK PAD		SAE 4320

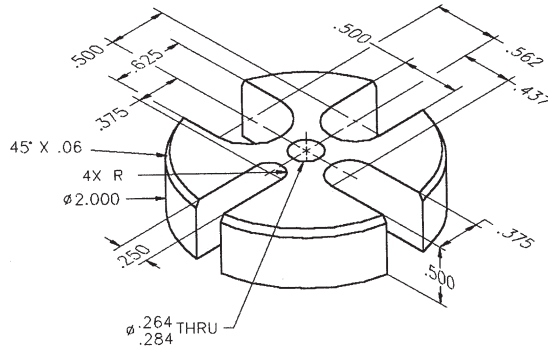
ITEM	QTY	NAME	DESCRIPTION	MATERIAL
9	1	COVER PLATE		SAE 1020
10	4	CAP SCREWS	8-32UNC-2 × .50 HEX SOC	STL
11	1	RACK		SAE 4320
12	1	SCREW		SAE 1040
13	1	COLUMN		SAE 1020
14	1	CAP SCREW	3/8-16UNC-2 × 1.00 HEX SOCKET HEAD	STL



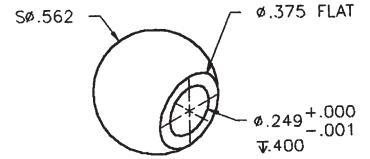
PROBLEM 15.15 (Continued)



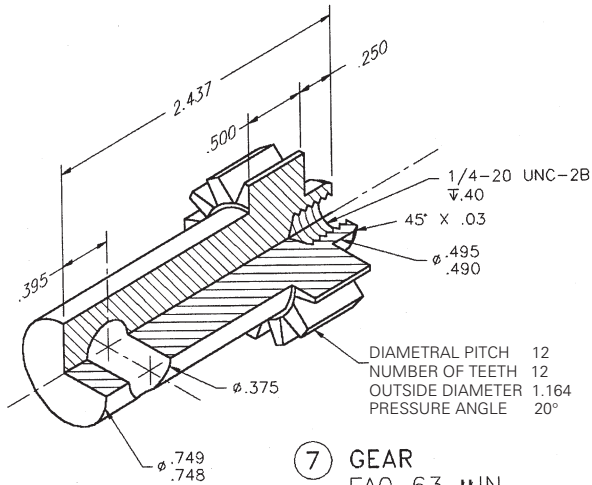
② TABLE PIN  
FAO 63  $\mu$ IN



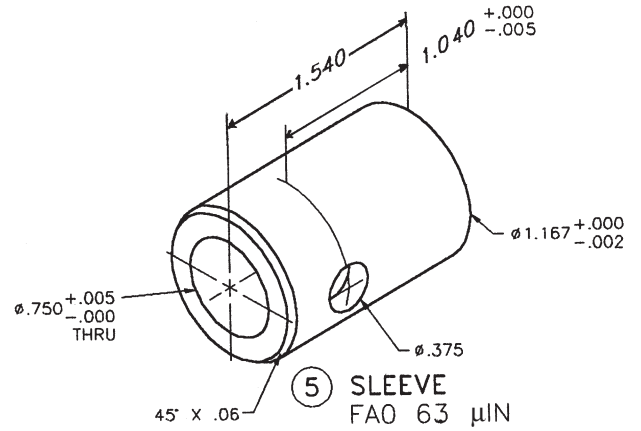
③ TABLE  
FAO 63  $\mu$ IN



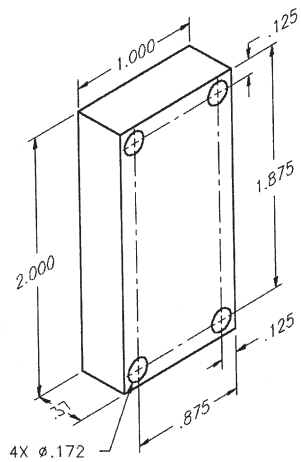
④ BALL END  
FAO 63  $\mu$ IN



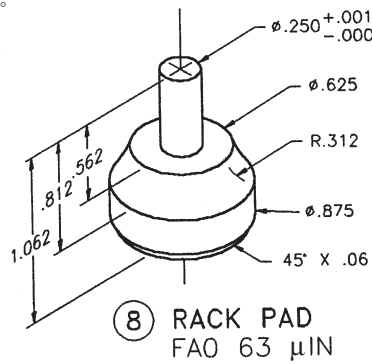
⑦ GEAR  
FAO 63  $\mu$ IN



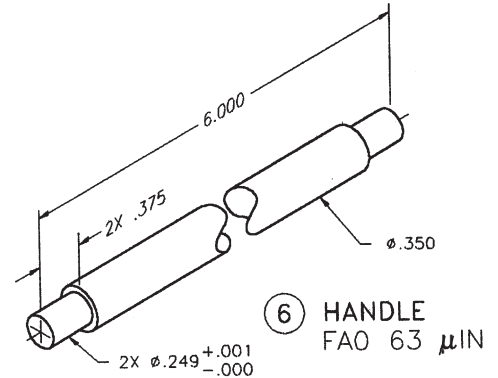
⑤ SLEEVE  
FAO 63  $\mu$ IN



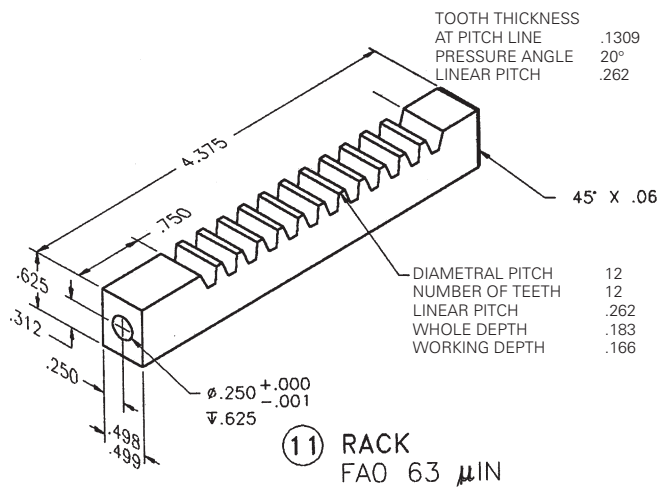
⑨ COVER PLATE  
FAO 63  $\mu$ IN



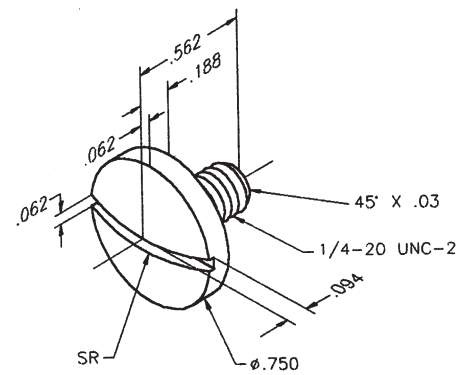
⑧ RACK PAD  
FAO 63  $\mu$ IN



⑥ HANDLE  
FAO 63  $\mu$ IN

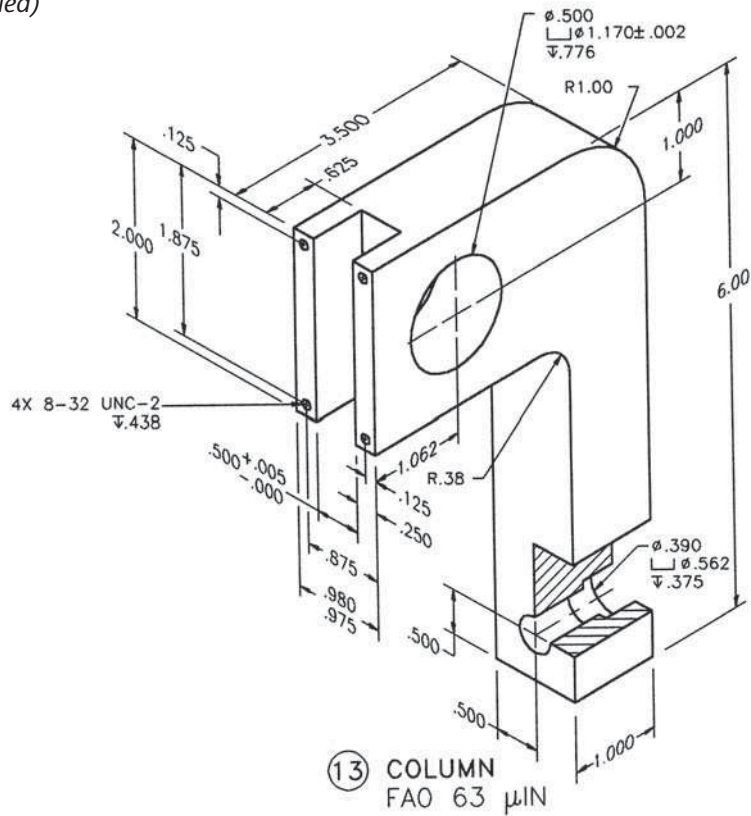


⑪ RACK  
FAO 63  $\mu$ IN



⑫ SCREW  
FAO 63  $\mu$ IN

PROBLEM 15.15 (Continued)



© Cengage Learning 2012

PROBLEM 15.16 Working drawing (in.)

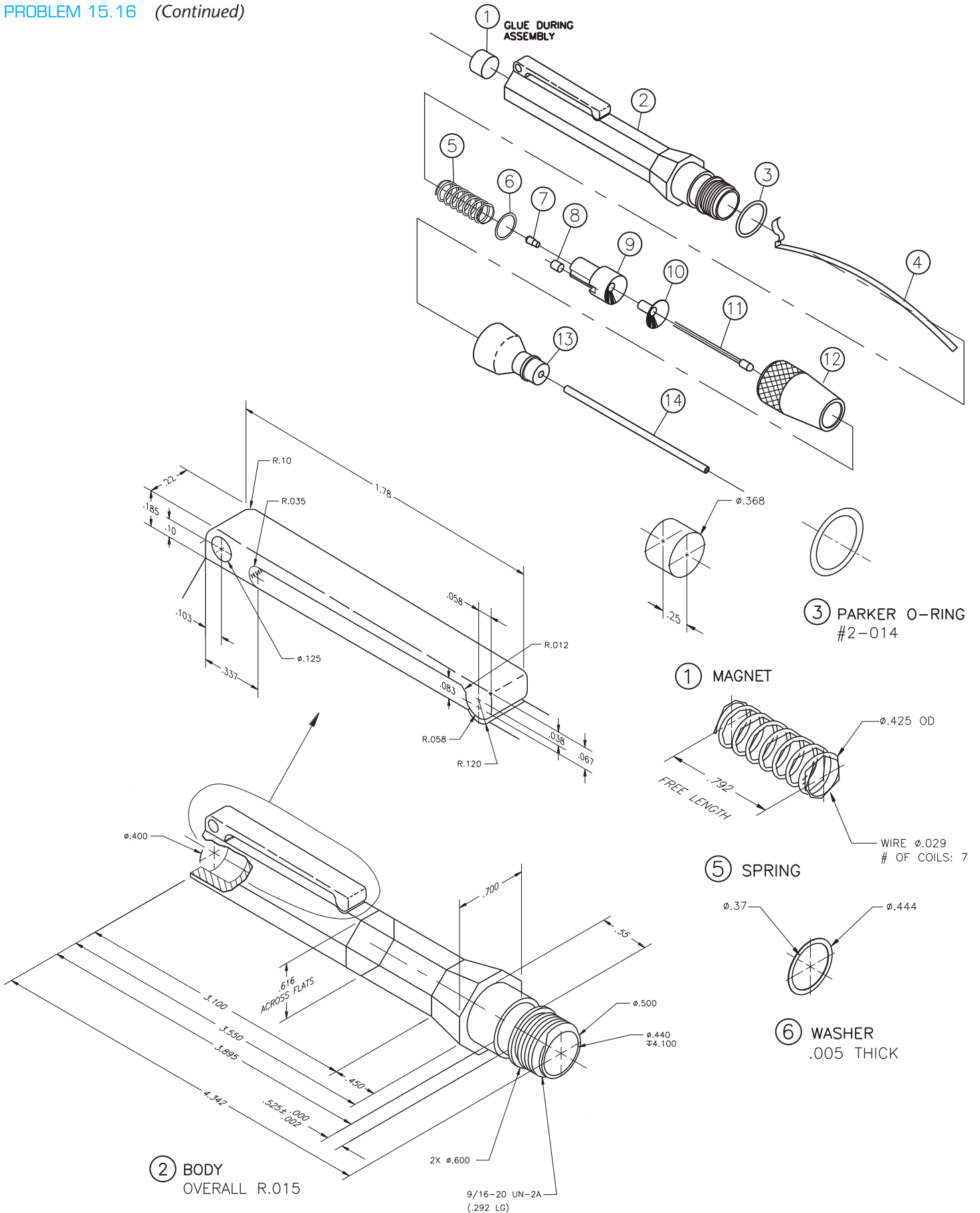
Assembly Name: Pen Light

SPECIFIC INSTRUCTIONS: Prepare a complete set of working drawings with one detail drawing per sheet and the assembly and parts list on another sheet. When preparing

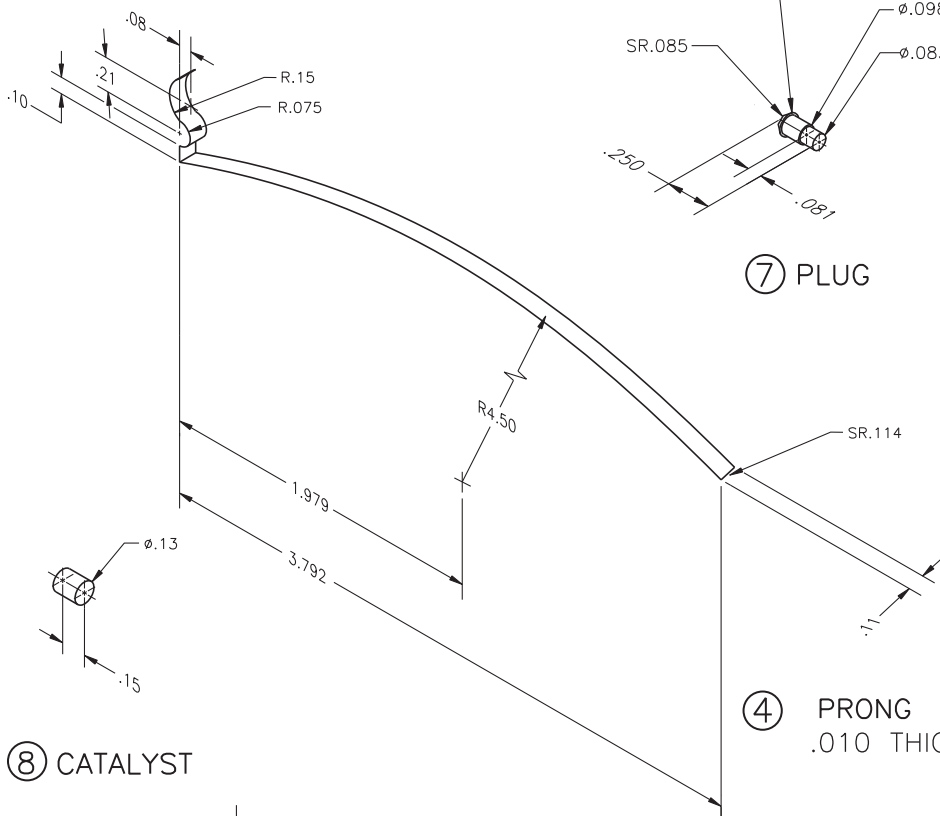
the assembly drawing, use separate balloons for each part in each view or use only one balloon in the view that most clearly identifies the part. This is an engineering prototype project. Errors are likely. Verify dimensions during assembly. Establish tolerances between mating parts.

PARTS LIST				
KEY	QTY	NAME	DESCRIPTION	PART NO.
1	1	MAGNET	MAGNET	5DT1001
2	1	BODY	POLYCARBONATE	1DT1002
3	1	PARKER O-RING	PARKER #2-014	5DT1003
4	1	PRONG	PHOSPHOR BRONZE	1DT1004
5	1	SPRING	PHOSPHOR BRONZE	1DT1005
6	1	WASHER	PHOSPHOR BRONZE	1DT1006
7	1	PLUG	PHOSPHOR BRONZE	1DT1007
8	1	CATALYST	DE OXO TYPE D	5DT1008
9	1	BULB CASING	POLYCARBONATE	1DT1009
10	1	LAMP MODULE	VACUUM METALLIZED	1DT1010
11	1	LAMP	HIGH INTENSITY XENON	5DT1011
12	1	LAMP LENS	POLYCARBONATE	1DT1012
13	1	FIBER OPTIC HOLDER	(PVF) POLYVINYLIDENE FLOURIDE	1DT1013
14	1	FIBER OPTIC	FIBER-OPTIC 3-1/2" x .12"	5DT1014

PROBLEM 15.16 (Continued)



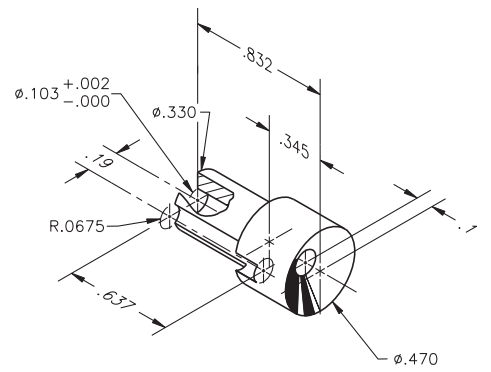
PROBLEM 15.16 (Continued)



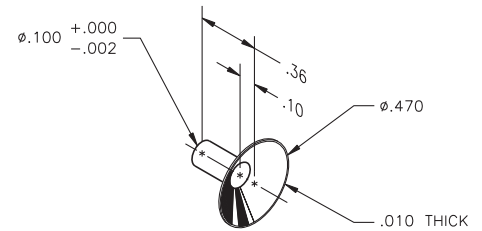
⑧ CATALYST

⑦ PLUG

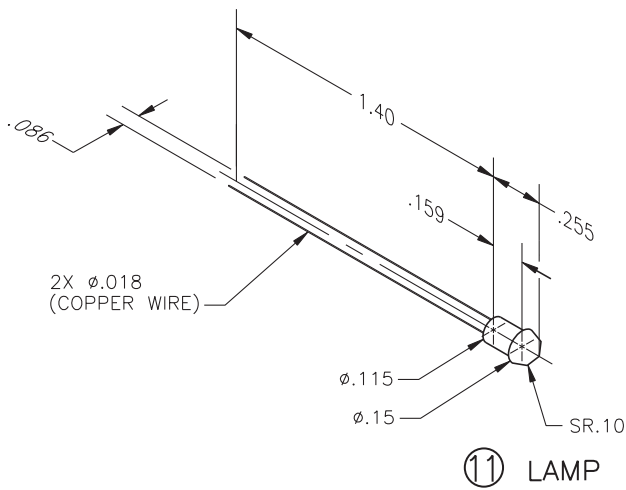
④ PRONG  
.010 THICK



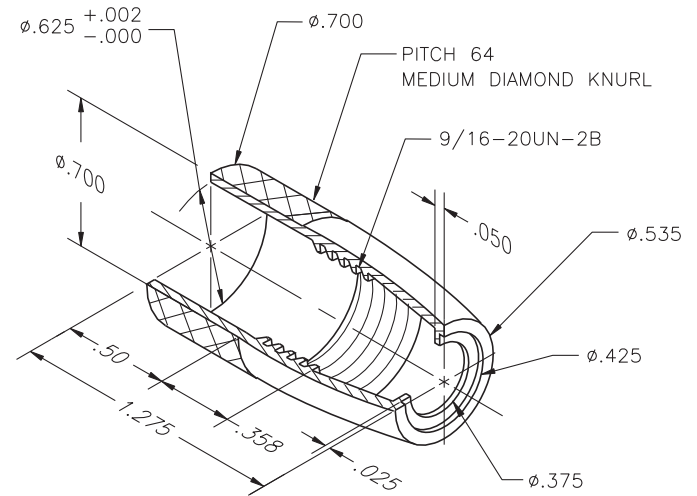
⑨ BULB CASING



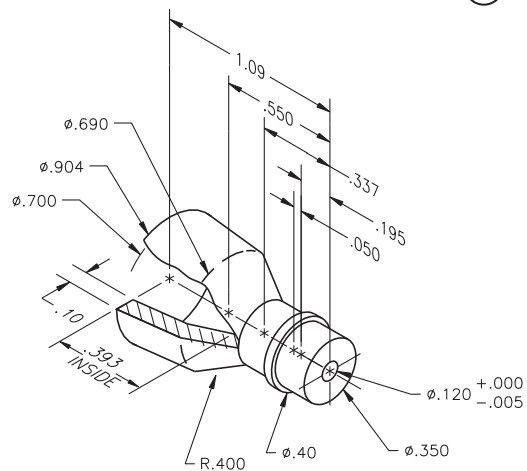
⑩ LAMP MODULE



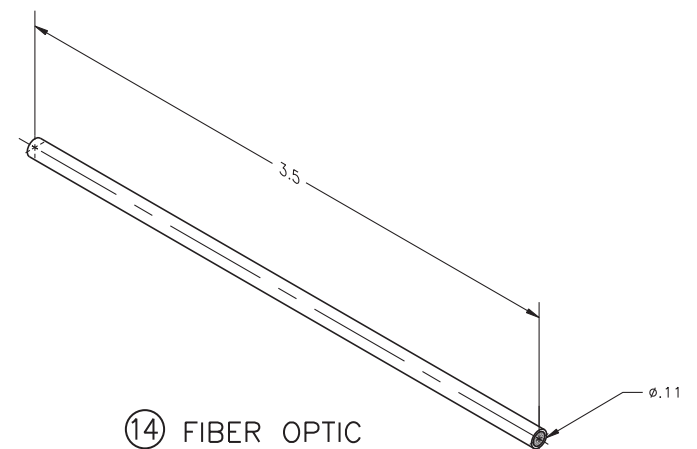
⑪ LAMP



⑫ LAMP LENS



⑬ FIBER OPTIC HOLDER



⑭ FIBER OPTIC

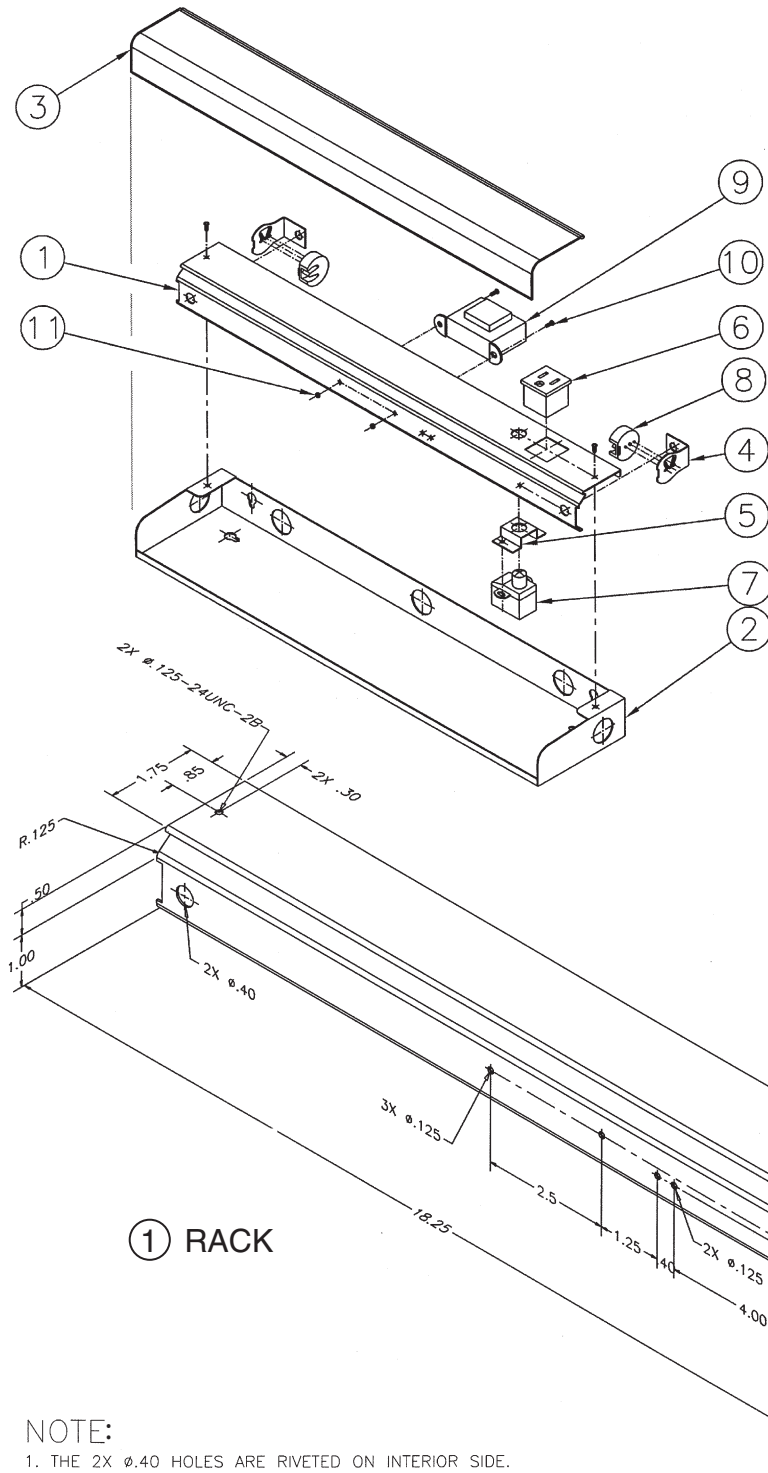
**PROBLEM 15.17 Working drawing (in.)**

Assembly Name: Fluorescent Light Fixture

SPECIFIC INSTRUCTIONS: Prepare a complete set of working drawings with one detail drawing per sheet and the assembly and parts list on another sheet. When preparing the assembly drawing, use separate balloons for each part in each view or use only one balloon in the view that most

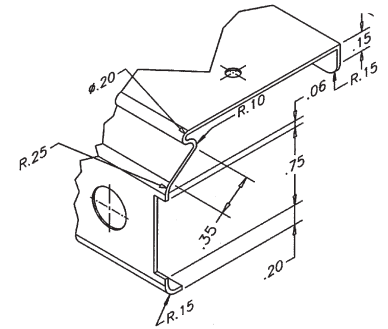
clearly identifies the part. This is an engineering prototype project. Errors are likely in this problem. Verify dimensions during assembly. Establish tolerances between mating parts. There are several purchase parts in this assembly. Manufacturer research is needed to locate available products.

PARTS LIST			
ITEM	QTY	NAME	DESCRIPTION
1	1	RACK	
2	1	BASE	
3	1	COVER	
4	2	END MOUNT	
5	1	SWITCH MOUNT	
6	1	OUTLET	SATCO OUTLET 3 WIRE
7	1	SWITCH	RACO PUSH BUTTON
8	2	FLOURESCENT END	EAGLE DOUBLE PIN TUBE
9	1	LIGHTING/VALMONT	89G457 BALLAS 1-20 WATT
10	6	MACHINE SCREW	Ø.125-24UNC-2A
11	2	HEX NUT	Ø.125-24UNC-2B



**NOTE:**

- ITEM 1, THE RACK HAS TWO RIVETED PIECES ON EACH INTERIOR SIDE TO CONNECT ITEM 4, THE END MOUNTS IN THE Ø.40 HOLE.

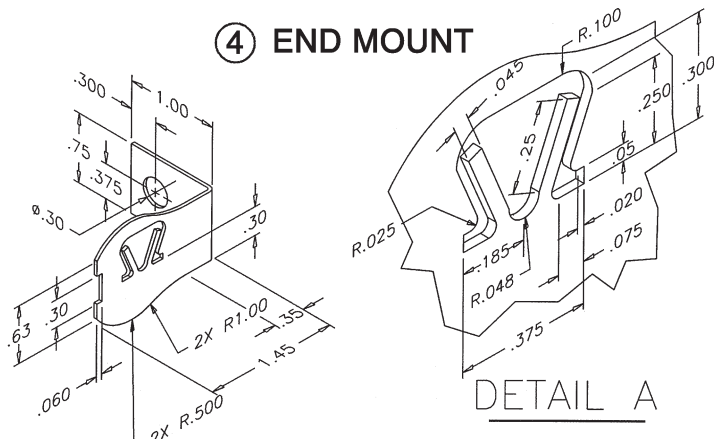
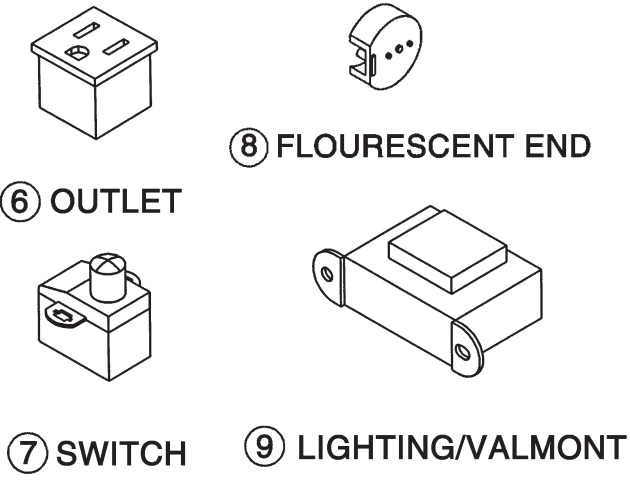
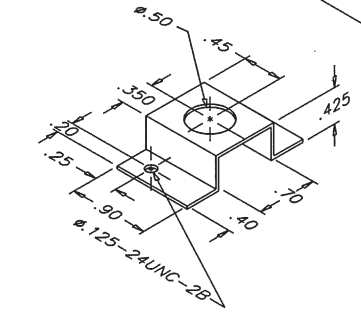
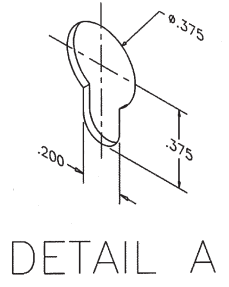
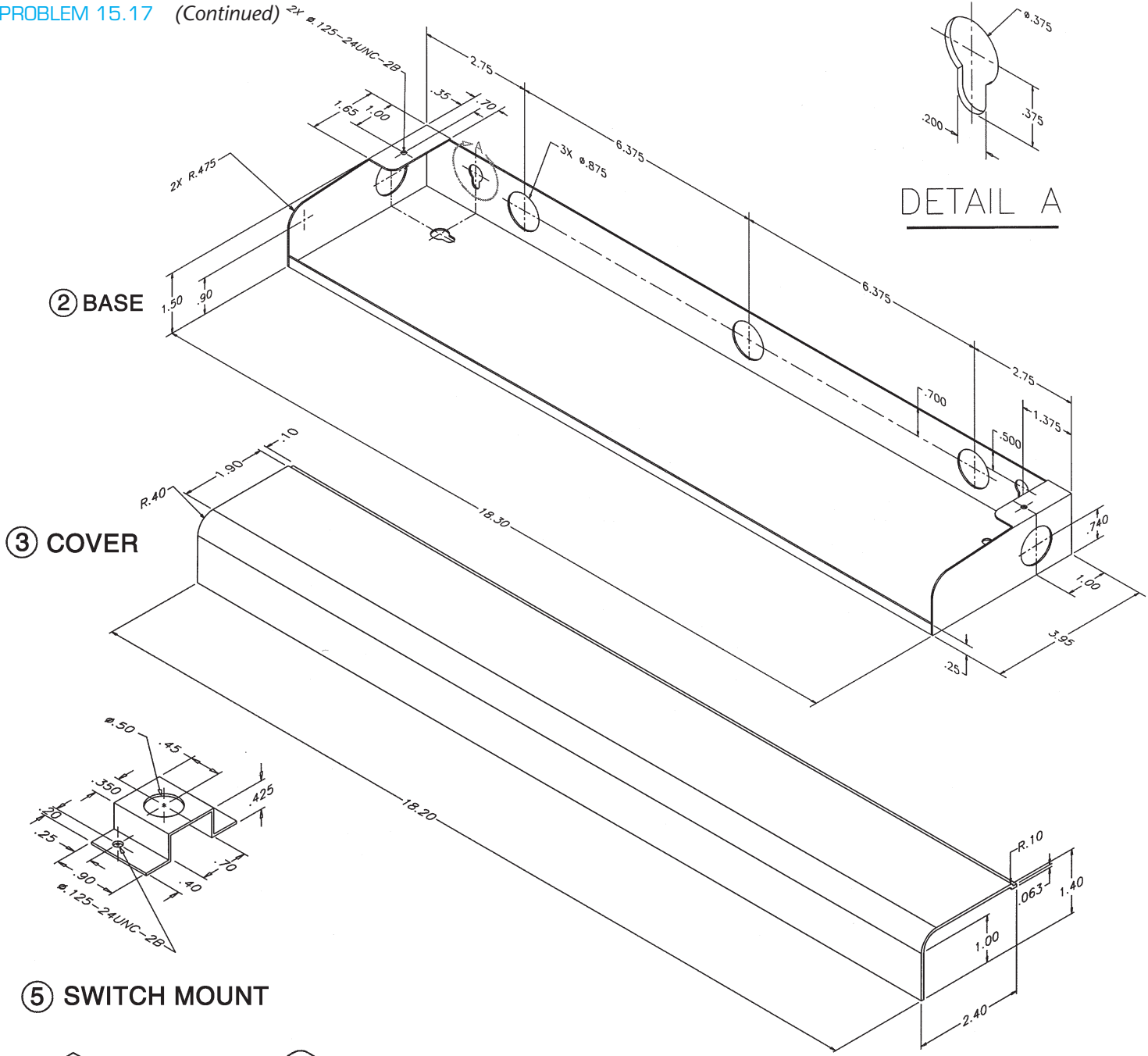


**DETAIL A**  
SCALE: 2:1

**NOTE:**

- THE 2X Ø.40 HOLES ARE RIVETED ON INTERIOR SIDE.

PROBLEM 15.17 (Continued)





**PROBLEM 15.18 Working drawing (in.)**

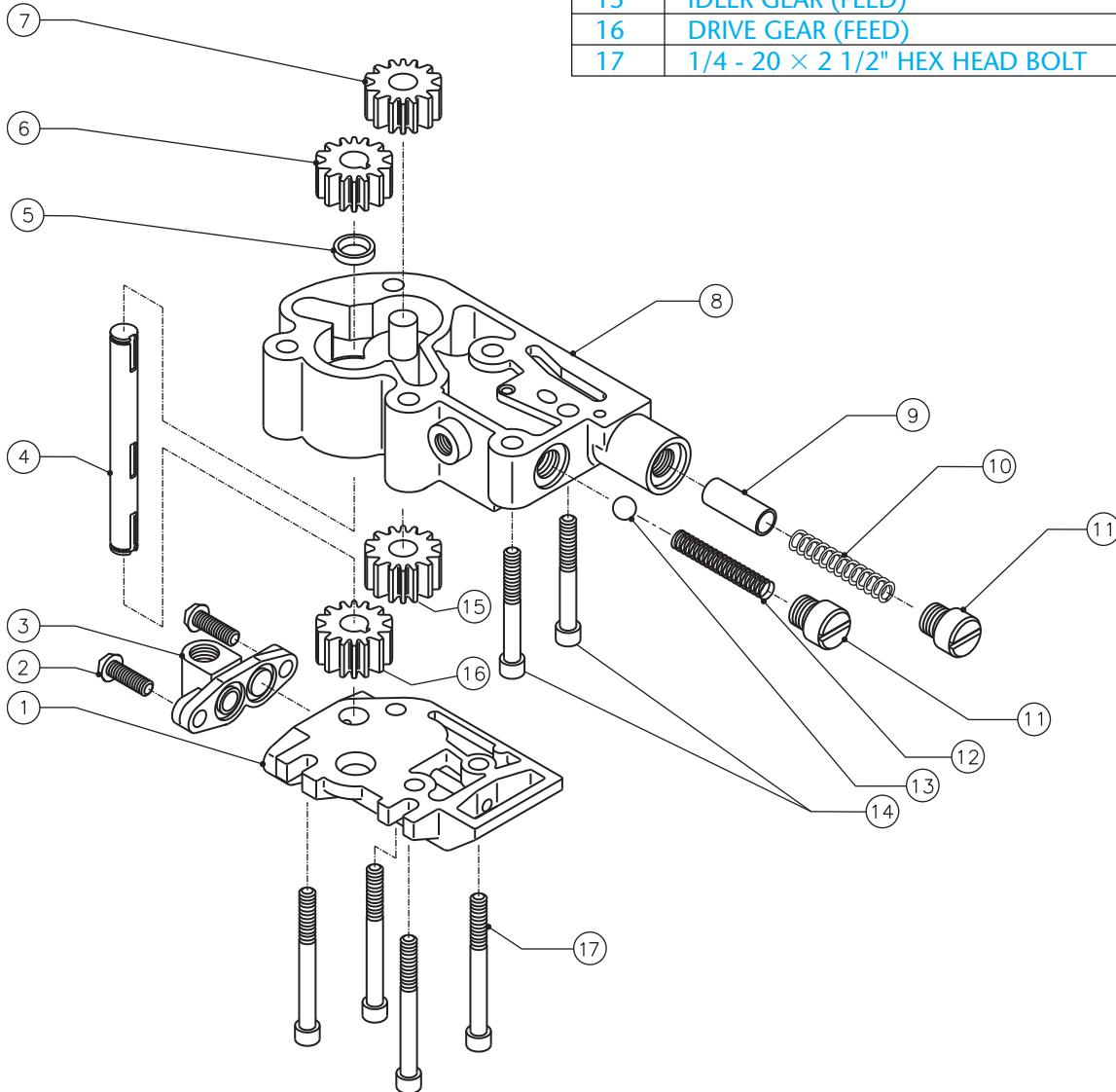
Assembly Name: Oil Pump

**SPECIFIC INSTRUCTIONS:** This problem is challenging, and contains applications that include gears and seals. You should study gears and related drafting practices covered in Chapter 16 before completing this problem.

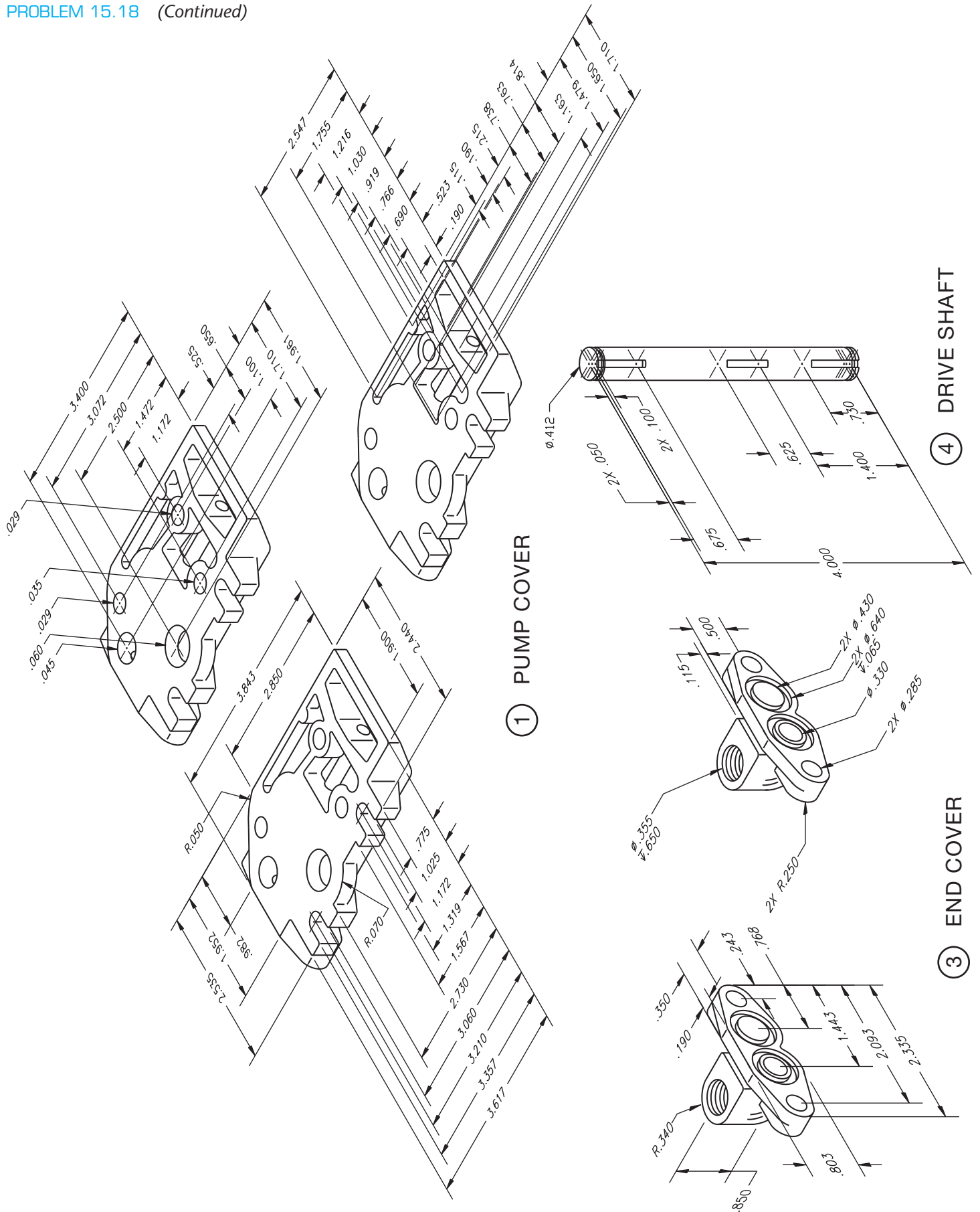
Prepare a complete set of working drawings with one detail drawing per sheet and the assembly and parts list on another sheet. When preparing the assembly drawing, use separate balloons for each part in each view or use only one balloon in the view that most clearly identifies the part. This is an engineering prototype project. Errors are likely in this problem. Verify dimensions during assembly. Establish tolerances between mating parts. There

are several purchase parts in this assembly. Manufacturer research is needed to locate available products.

PARTS LIST		
ITEM	DESCRIPTION	QTY
1	PUMP COVER	1
2	1/4 - 20 × 3/4" BUTTON HEAD BOLT	2
3	END COVER	1
4	DRIVE SHAFT	1
5	OIL SEAL	1
6	DRIVE GEAR (RETURN)	1
7	IDLER GEAR (RETURN)	1
8	OIL PUMP BODY	1
9	PLUNGER VALVE	1
10	PLUNGER SPRING	1
11	END CAP	2
12	PSI CONTROL SPRING	1
13	CHECK BALL	1
14	1/4 - 20 × 2" HEX HEAD BOLT	2
15	IDLER GEAR (FEED)	1
16	DRIVE GEAR (FEED)	1
17	1/4 - 20 × 2 1/2" HEX HEAD BOLT	4



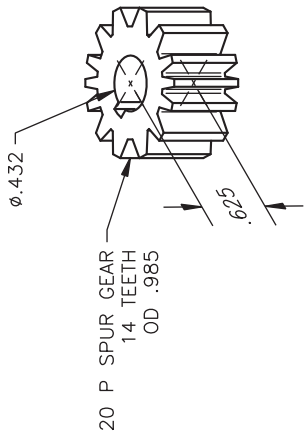
PROBLEM 15.18 (Continued)



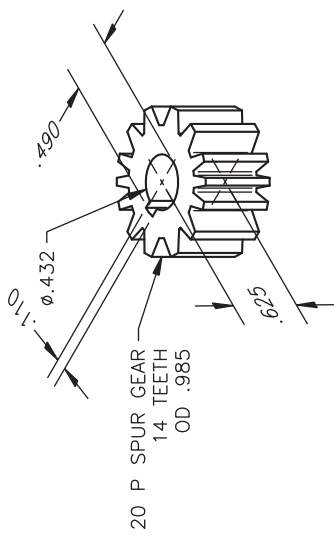
④ DRIVE SHAFT

① PUMP COVER

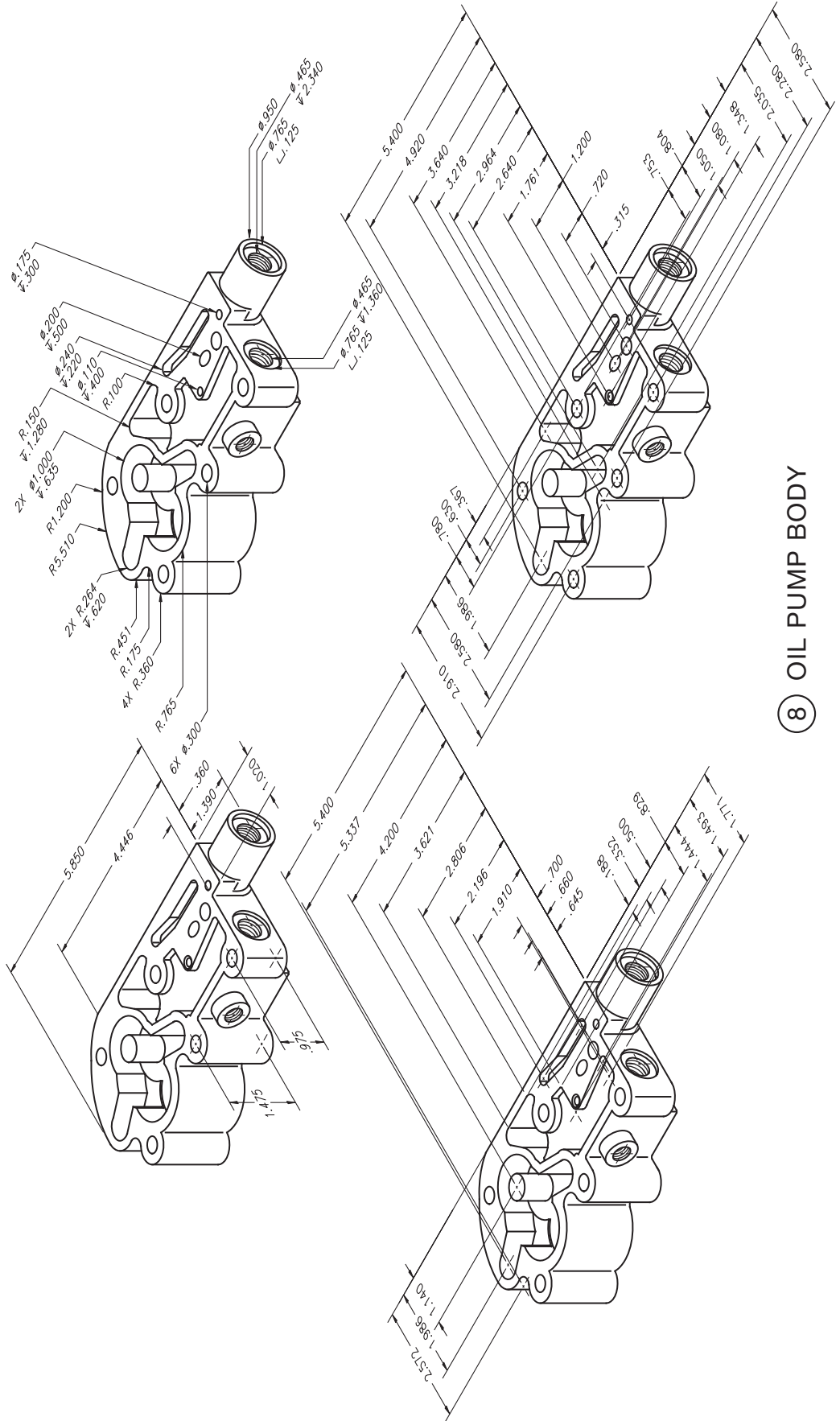
③ END COVER



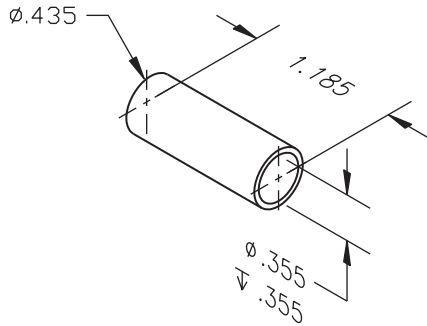
⑦ IDLER GEAR (RETURN)



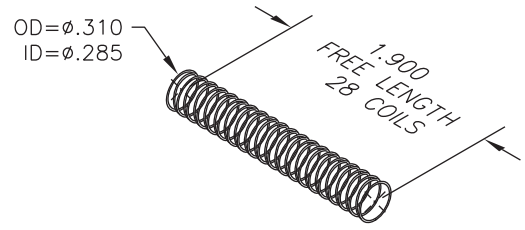
⑥ DRIVE GEAR (RETURN)



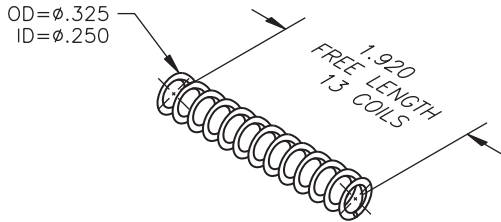
PROBLEM 15.18 (Continued)



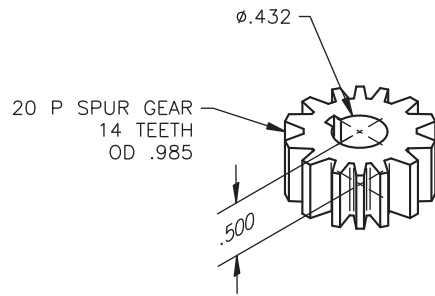
9 PLUNGER VALVE



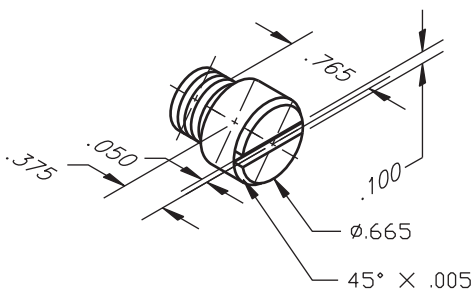
12 PSI CONTROL SPRING



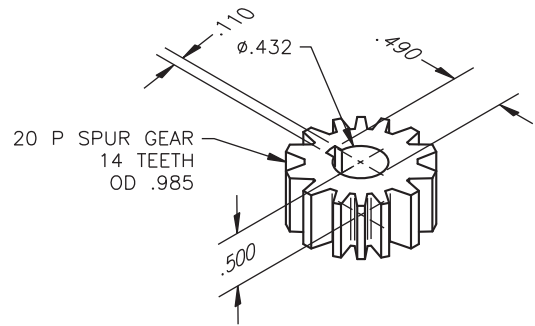
10 PLUNGER SPRING



15 IDLER GEAR (FEED)



11 END CAP



16 DRIVE GEAR (FEED)

**PROBLEM 15.19 Working drawing (in.)**

Assembly Name: Landing Gear Retract Assembly

**SPECIFIC INSTRUCTIONS:** This problem is challenging and contains applications that include gears. You should study gears and related drafting practices covered in Chapter 16 before completing this problem.

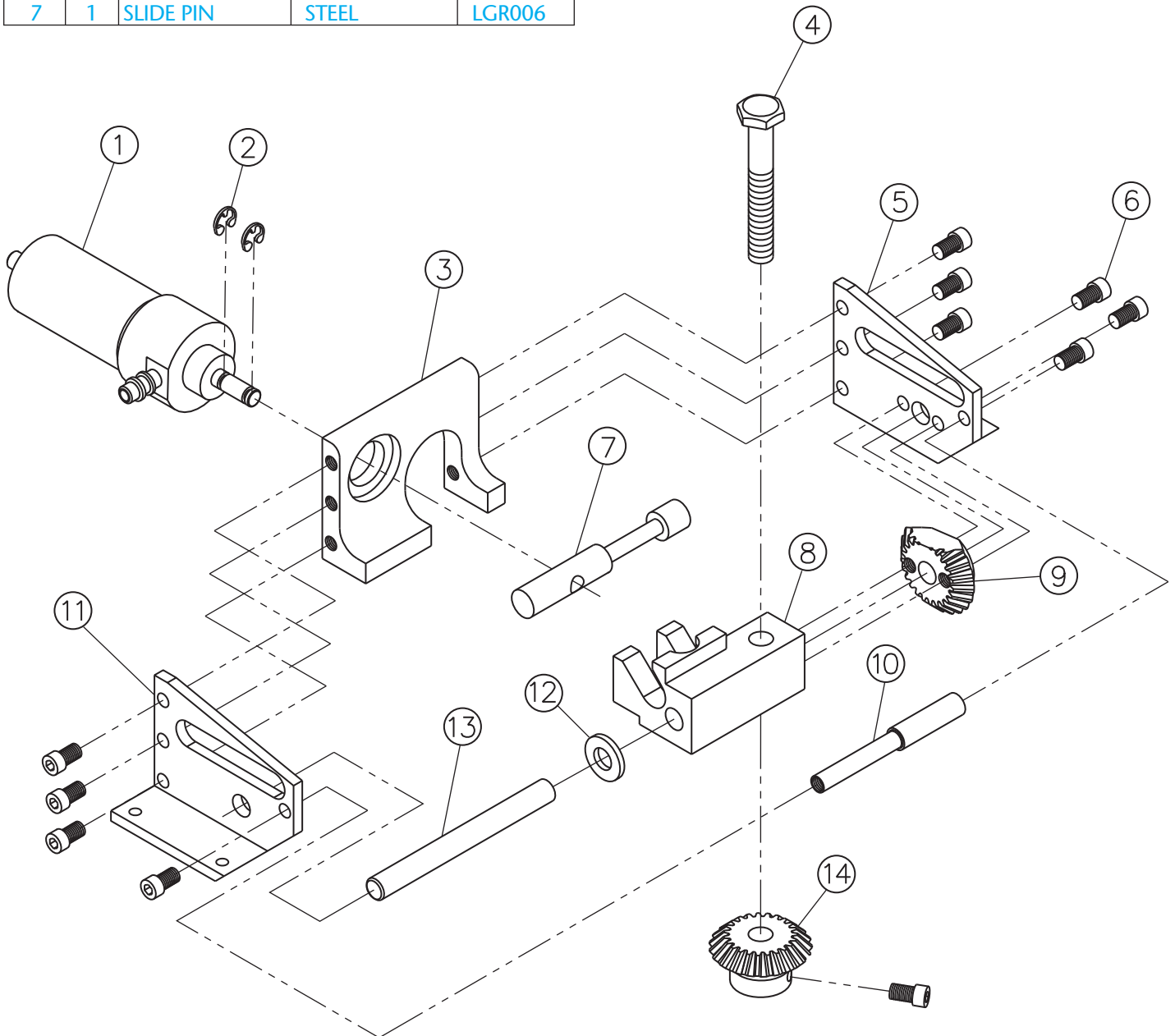
Prepare a complete set of working drawings with one detail drawing per sheet and the assembly and parts list

on another sheet. When preparing the assembly drawing, use separate balloons for each part in each view or use only one balloon in the view that most clearly identifies the part. This is an engineering prototype project. Errors are likely in this problem. Verify dimensions during assembly. Establish tolerances between mating parts. There are several purchase parts in this assembly. Manufacturer research is needed to locate available products.

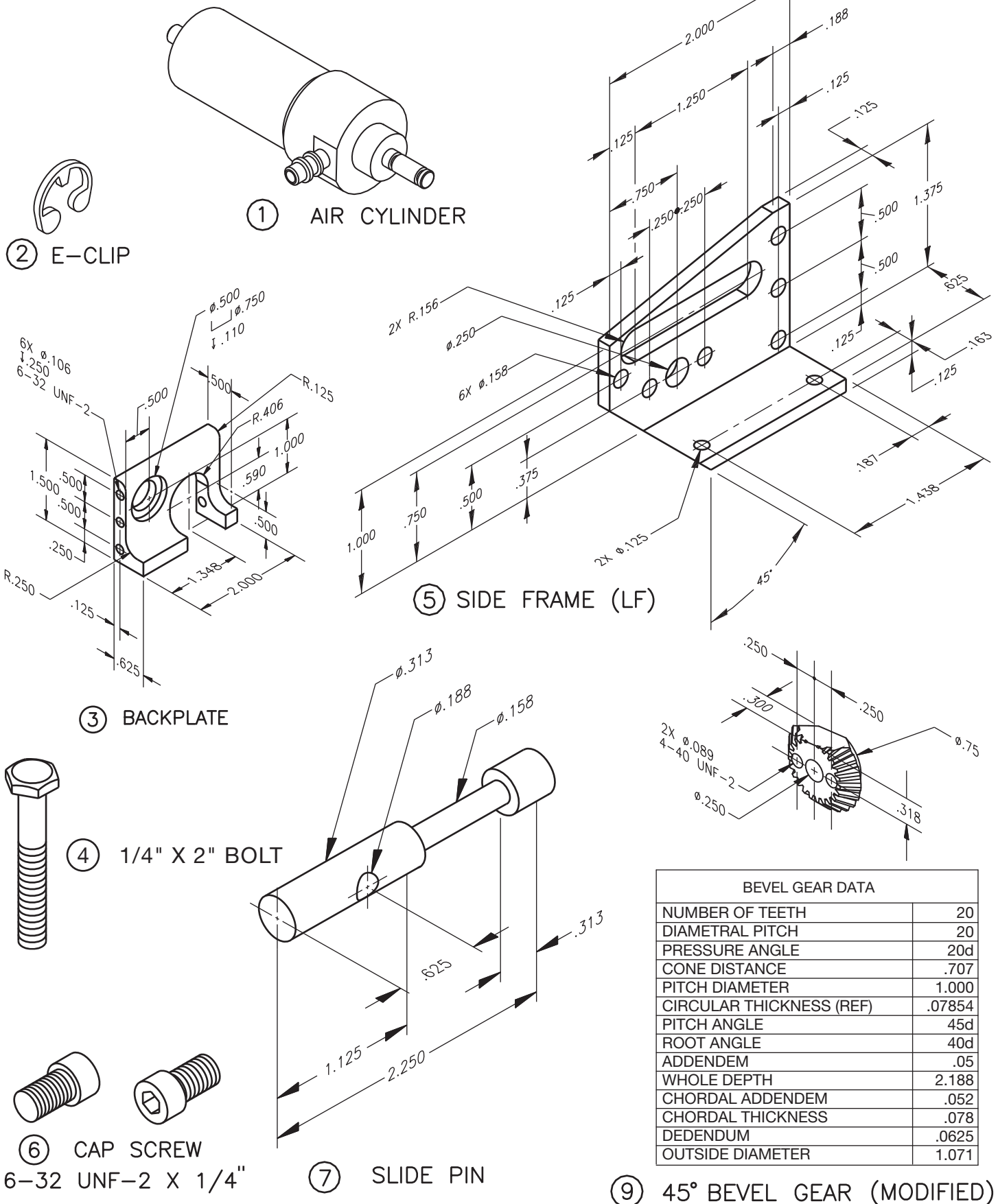
**PARTS LIST**

ITEM	QTY	NAME	DESCRIPTION	PART NO.
1	1	AIR CYLINDER	CLIPPERD	CL0002
2	2	E-CLIP	1/8"	EC0018
3	1	BACKPLATE	ALUMINUM	LGR001
4	1	1/4" × 2" BOLT	2" HARD BOLT	BT0002
5	1	SIDE FRAME (LF)	ALUMINUM	LGR003
6	11	CAP SCREW	6-32UNF-2 × 1/4"	CS0012
7	1	SLIDE PIN	STEEL	LGR006

ITEM	QTY	NAME	DESCRIPTION	PART NO.
8	1	CENTER BLOCK	ALUMINUM	LGR005
9	1	45° BEVEL GEAR	MODIFIED	BG0002
10	1	SPACER	ALUMINUM	LGR007
11	1	SIDE FRAME (RT)	ALUMINUM	LGR002
12	1	WASHER	BRASS	WA0014
13	1	PIVOT PIN	HARD STEEL	LGR008
14	1	45° BEVEL GEAR	BROWNING	BG0001

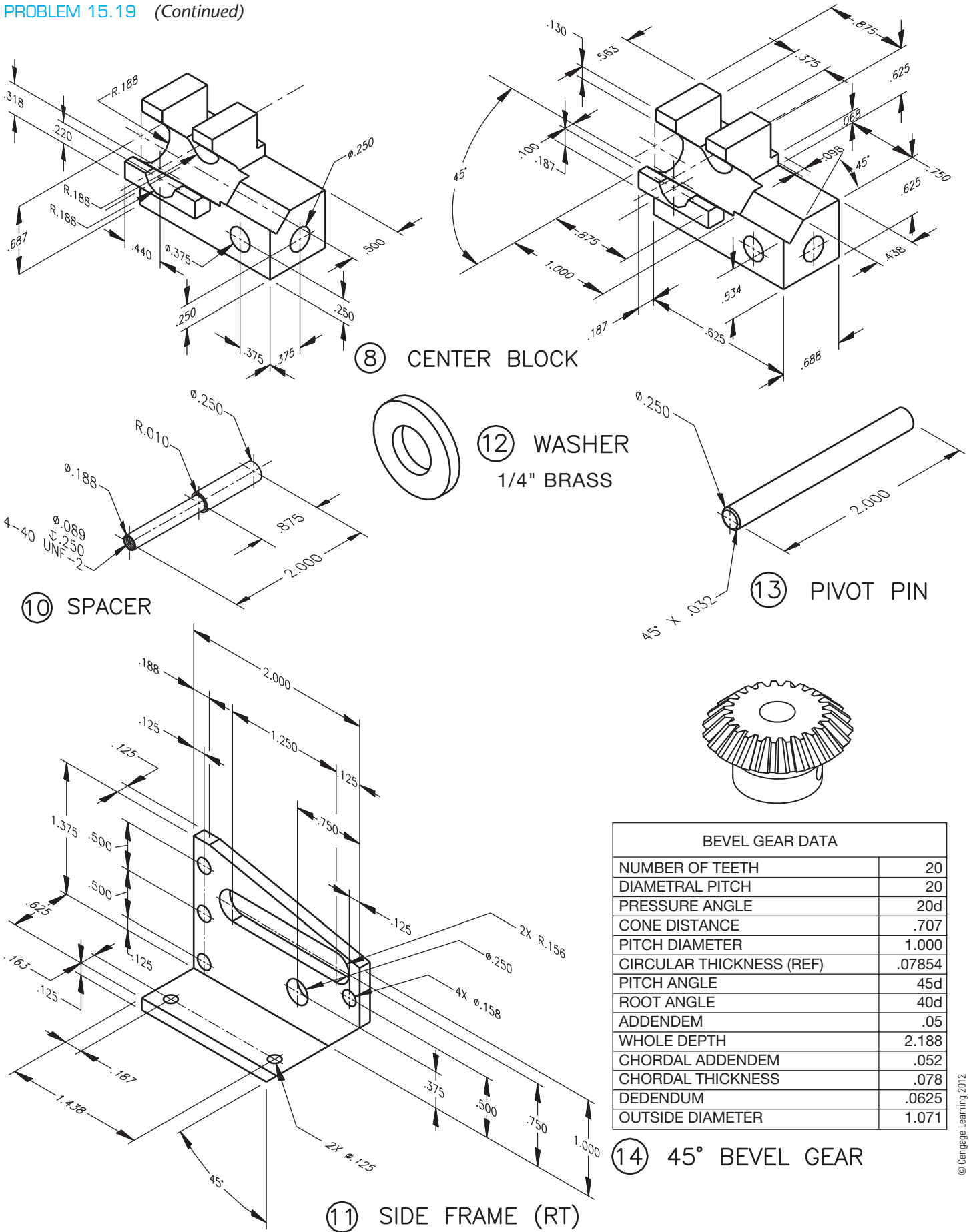


PROBLEM 15.19 (Continued)



BEVEL GEAR DATA	
NUMBER OF TEETH	20
DIAMETRAL PITCH	20
PRESSURE ANGLE	20d
CONE DISTANCE	.707
PITCH DIAMETER	1.000
CIRCULAR THICKNESS (REF)	.07854
PITCH ANGLE	45d
ROOT ANGLE	40d
ADDENDEM	.05
WHOLE DEPTH	2.188
CHORDAL ADDENDEM	.052
CHORDAL THICKNESS	.078
DEDENDUM	.0625
OUTSIDE DIAMETER	1.071

PROBLEM 15.19 (Continued)



BEVEL GEAR DATA	
NUMBER OF TEETH	20
DIAMETRAL PITCH	20
PRESSURE ANGLE	20d
CONE DISTANCE	.707
PITCH DIAMETER	1.000
CIRCULAR THICKNESS (REF)	.07854
PITCH ANGLE	45d
ROOT ANGLE	40d
ADDENDUM	.05
WHOLE DEPTH	2.188
CHORDAL ADDENDUM	.052
CHORDAL THICKNESS	.078
DEDENDUM	.0625
OUTSIDE DIAMETER	1.071

© Cengage Learning 2012

**PROBLEM 15.20 Working drawing (in.)**

Assembly Name: Hydraulic Jack

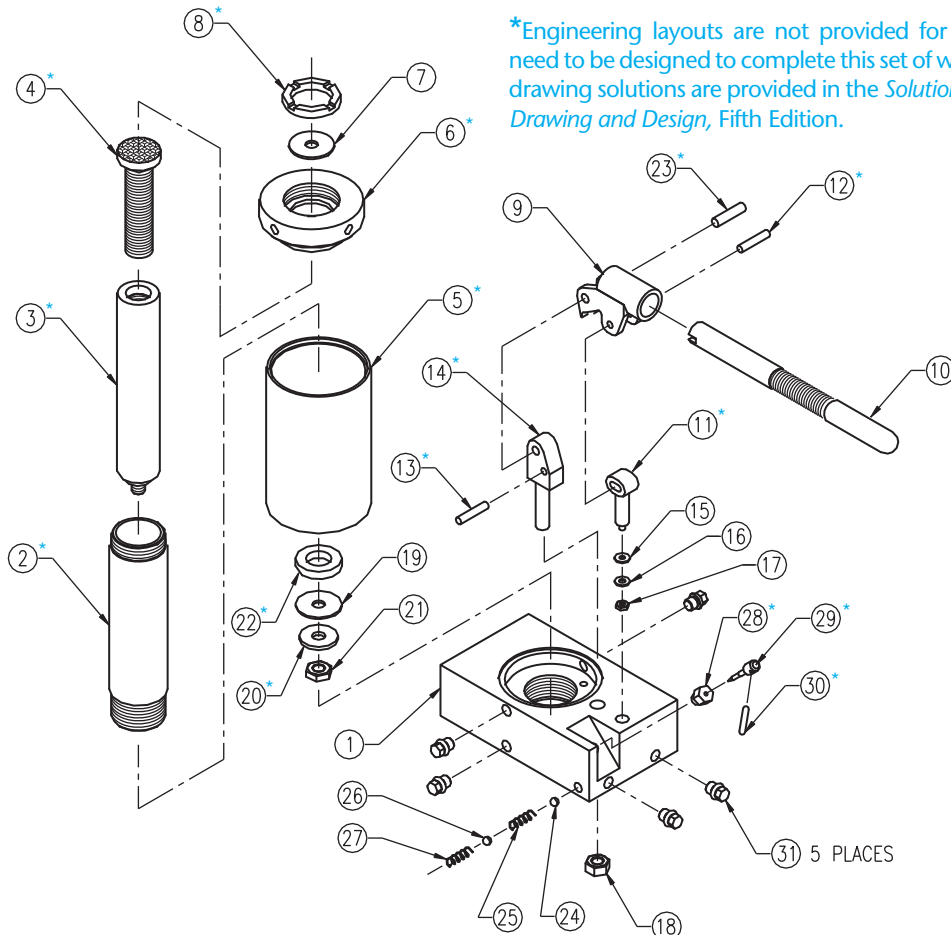
SPECIFIC INSTRUCTIONS: This problem is challenging and advanced.

Prepare a complete set of working drawings with one detail drawing per sheet and the assembly and parts list on another sheet. When preparing the assembly drawing, use separate

balloons for each part in each view or use only one balloon in the view that most clearly identifies the part. This is an engineering prototype project. Errors are likely in this problem. Verify dimensions during assembly. Establish tolerances between mating parts. Several purchase parts and parts need to be designed in this assembly. Manufacturer research is needed to locate available products.

**PARTS LIST**

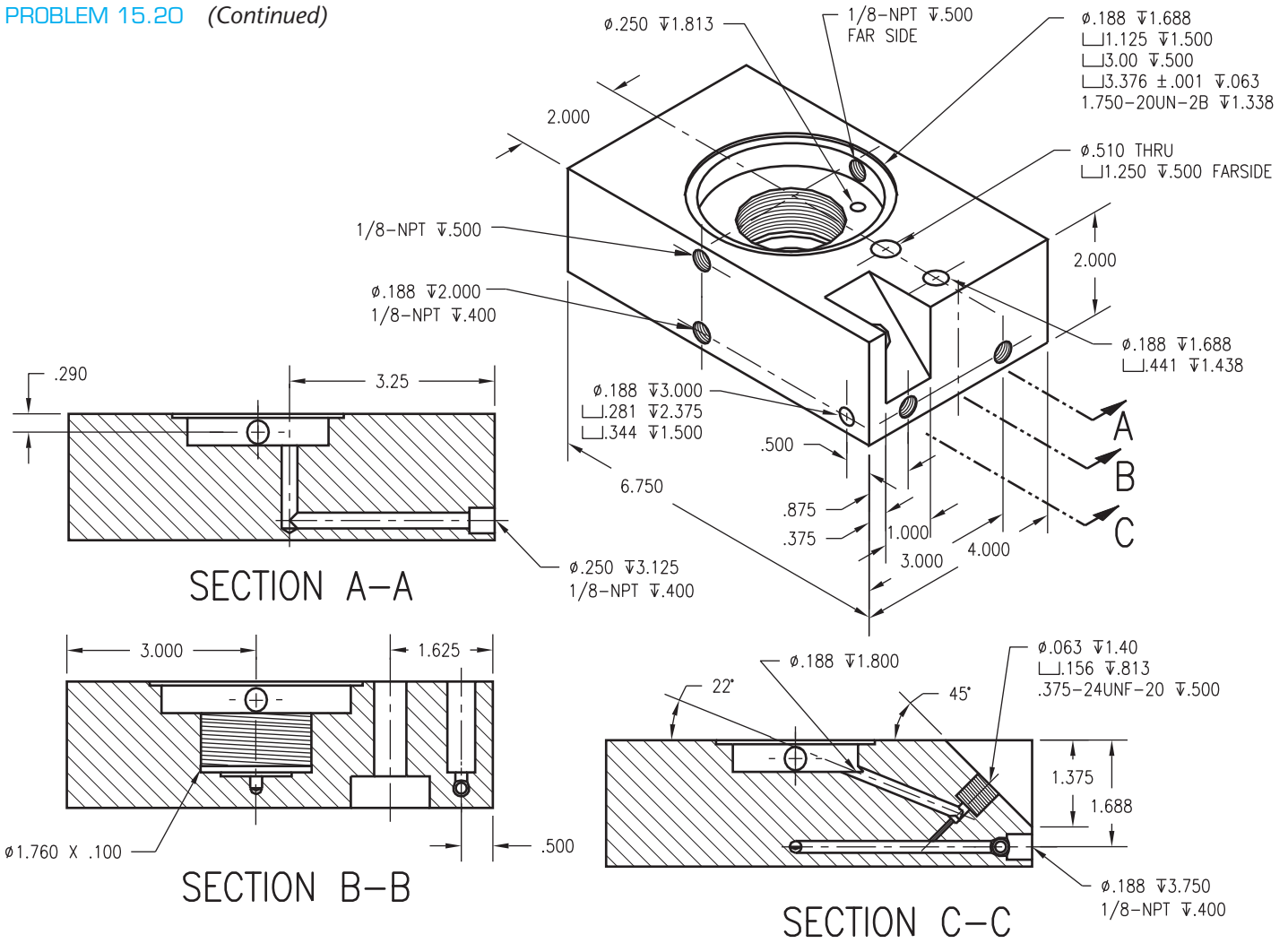
KEY	QTY	NAME	DESCRIPTION	PART NO.	KEY	QTY	NAME	DESCRIPTION	PART NO.
1	1	BASE	JACK	1DT1001	18	1	NUT	.437-14 UNC-2B	5DT1018
2*	1	TUBE	CYLINDER	1DT1002	19	1	CUP	Ø1.500 LEATHER	5DT1019
3*	1	PISTON	JACK	1DT1003	20*	1	WASHER	PISTON	1DT1020
4*	1	SCREW	JACK	1DT1004	21	1	NUT	.437-20 UNF-2B	5DT1021
5*	1	TUBE	RESERVOIR	1DT1005	22*	1	GUIDE	BRONZE	1DT1022
6*	1	CAP	TOP	1DT1006	23*	1	PIN	PIVOT	1DT1023
7	1	PACKING	Ø1.500 LEATHER	5DT1007	24	1	BALL	Ø.250	5DT1024
8*	1	NUT	PACKING	1DT1008	25	1	SPRING	Ø.281 × 1.000 CLOSED ENDS, 6 COILS	5DT1025
9	1	SOCKET	PUMP HANDLE	1DT1009	26	1	BALL	Ø.3125	5DT1026
10*	1	HANDLE	PUMP	1DT1010	27	1	SPRING	Ø.343 × 1.250 CLOSED ENDS, 9 COILS	5DT1027
11*	1	PLUNGER	PUMP	1DT1011	28*	1	NUT	NEEDLE VALVE	1DT1028
12*	1	PIN	DRIVE	1DT1012	29*	1	VALVE	NEEDLE	1DT1029
13*	1	PIN	STOP	1DT1013	30*	1	HANDLE	NEEDLE VALVE	1DT1030
14*	1	SUPPORT	PUMP PIVOT	1DT1014	31	5	PLUG	1/8-27 NPT	5DT1031
15	1	CUP SEAL	Ø.445 NEOPRENE	5DT1015					
16	1	WASHER	ANS TYPE B PLAIN NO. 10 N SERIES	5DT1016					
17	1	NUT	10-32 UNF-2B	5DT1017					



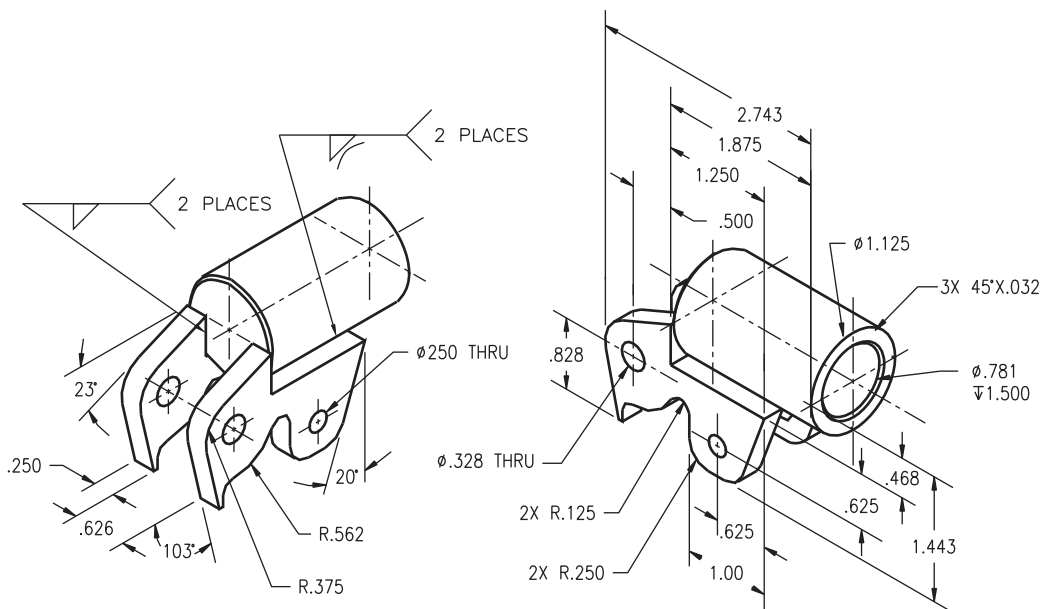
\*Engineering layouts are not provided for these parts. These parts need to be designed to complete this set of working drawings. Possible drawing solutions are provided in the *Solutions Manual, for Engineering Drawing and Design, Fifth Edition*.



PROBLEM 15.20 (Continued)



① BASE



⑨ SOCKET

**PROBLEM 15.21 Working drawing (in.)**

Assembly Name: Worm Gear Reducer

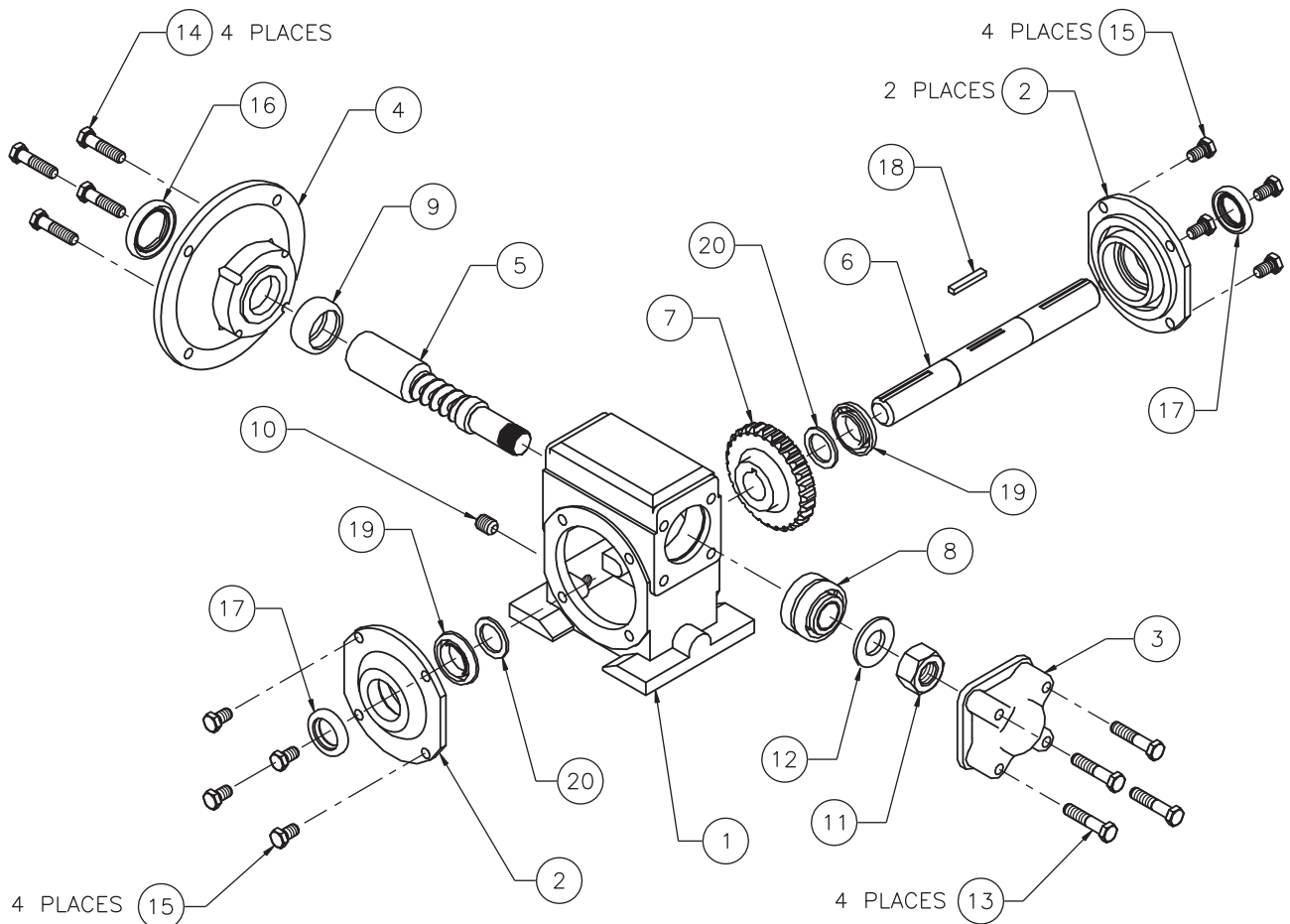
SPECIFIC INSTRUCTIONS: This problem is demanding, and it contains challenging applications that include gears and bearings. You should study gears and related drafting practices covered in Chapter 16 before completing this problem. This is an advanced project, and design changes may be required. Prepare a complete set of working drawings with one

detail drawing per sheet and the assembly and parts list on another sheet. When preparing the assembly drawing, use separate balloons for each part in each view or use only one balloon in the view that most clearly identifies the part. This is an engineering prototype project. Errors are likely in this problem. Verify dimensions during assembly. Establish tolerances between mating parts. A completed assembly drawing and parts list for this problem is shown in Figure 15.24.

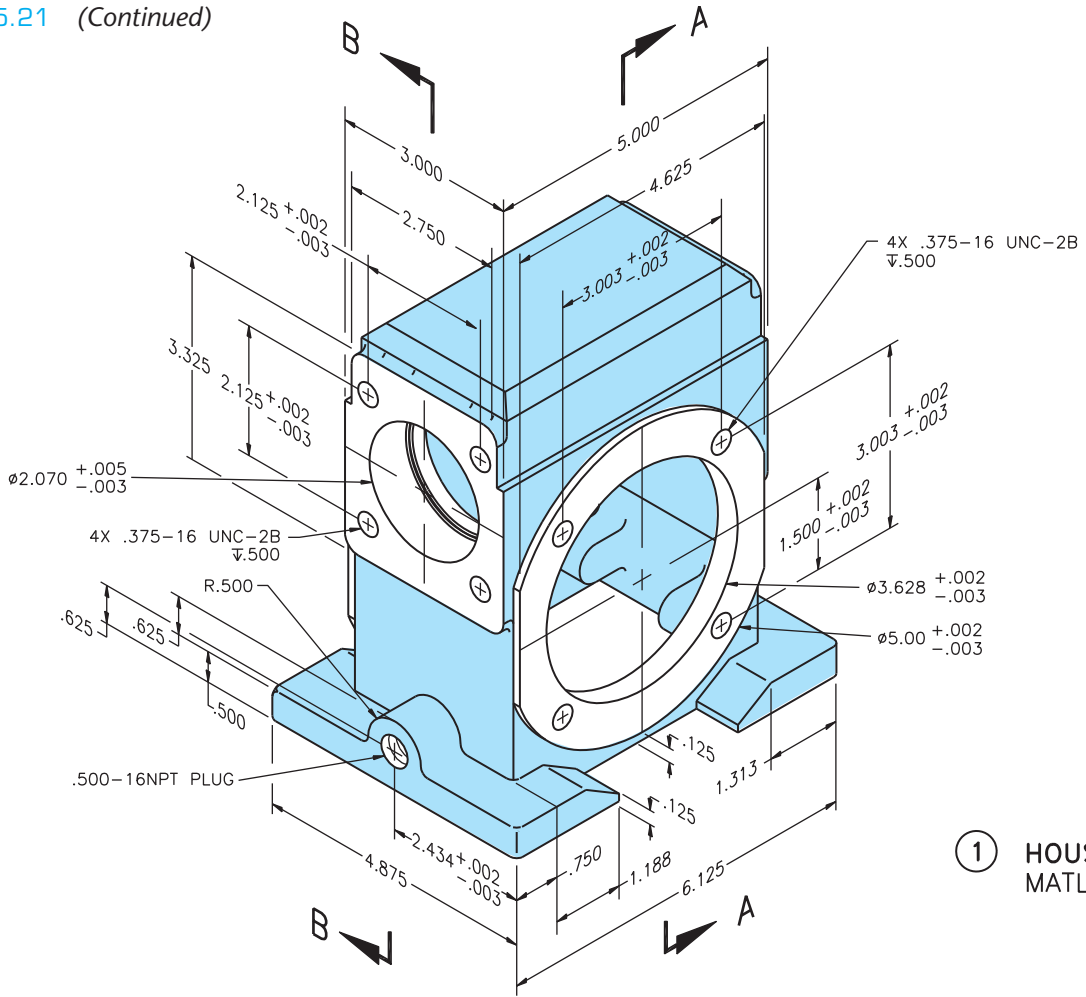
**PARTS LIST**

ITEM	QTY	NAME	DESCRIPTION
1	1	HOUSING	
2	2	RETAINING PLATE	
3	1	BEARING CAP	
4	1	MOTOR ADAPTER	
5	1	HIGH SPEED SHAFT	
6	1	SLOW SPEED SHAFT	
7	1	WORM GEAR	BRONZE
8	1	DBL. ROW TAPERED ROLLER BEARING	KOYO46T30305DJ/29.5
9	1	SNGL. ROW CYL. ROLLER BEARING	KOYO CRL11
10	1	TAPER PLUG	500-16NPT PLUG
11	1	HEX NUT	.875-16 UN-28
12	4	HIGH SPEED LOCKWASHER	TIMKEN TW-105

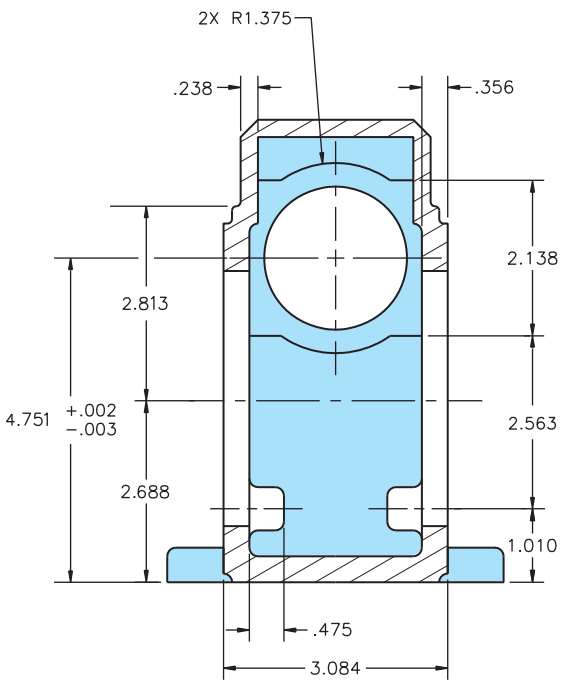
ITEM	QTY	NAME	DESCRIPTION
13	4	MACHINE SCREW	.375-16UNC-2A × 1.813 HEX HEAD
14	4	MACHINE SCREW	.375-16UNC-2A × 1.625 HEX HEAD
15	8	MACHINE SCREW	.375-16UNC-2A × .625 HEX HEAD
16	1	HIGH SPEED OIL SEAL	PARKER 2-028
17	2	SLOW SPEED OIL SEAL	PARKER 2-020
18	1	SLOW SPEED KEYWAY	.1875 × .245 × 1.450
19	1	SNGL. ROW TAP ROLLER BEARING	KOYO 32005J
20	2	SLOW SPEED SPACER	TIMKEN TW-506



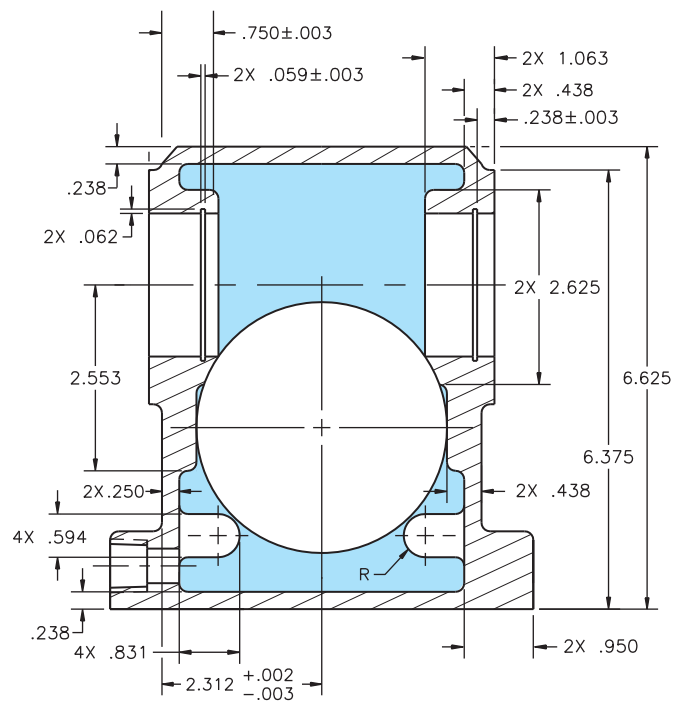
PROBLEM 15.21 (Continued)



① HOUSING  
MATL: CI

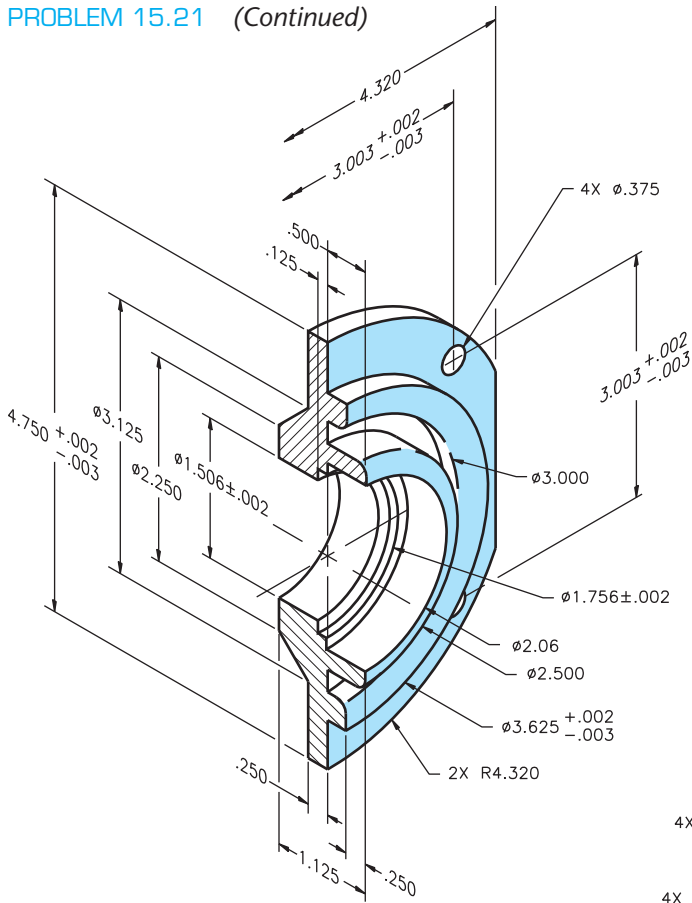


SECTION A-A

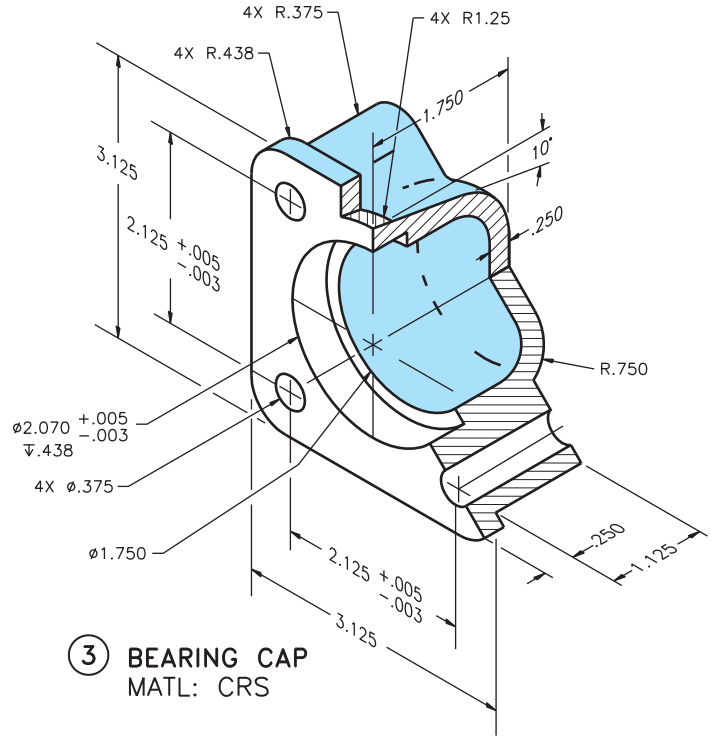


SECTION B-B

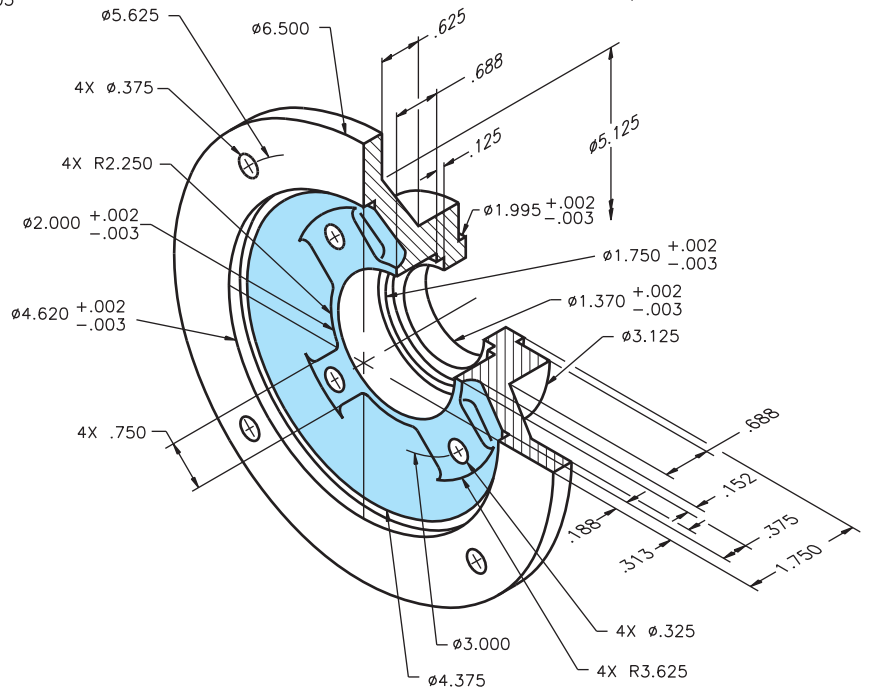
PROBLEM 15.21 (Continued)



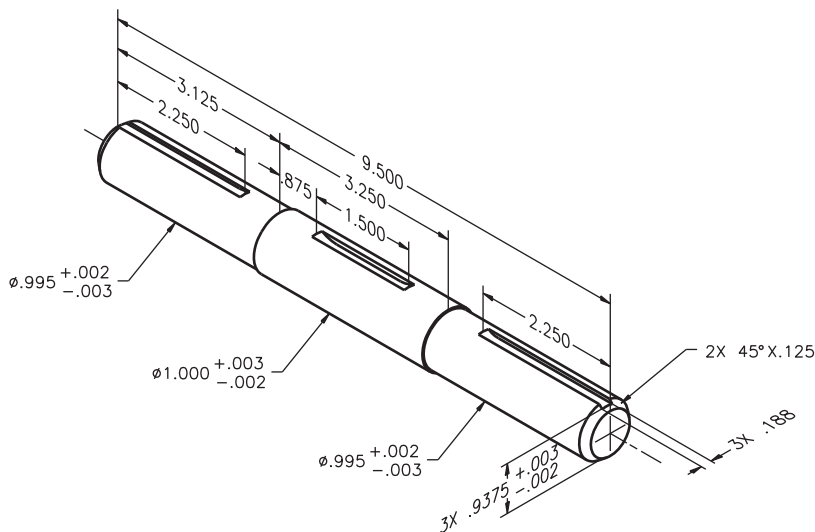
② RETAINING PLATE  
MATL: CI



③ BEARING CAP  
MATL: CRS



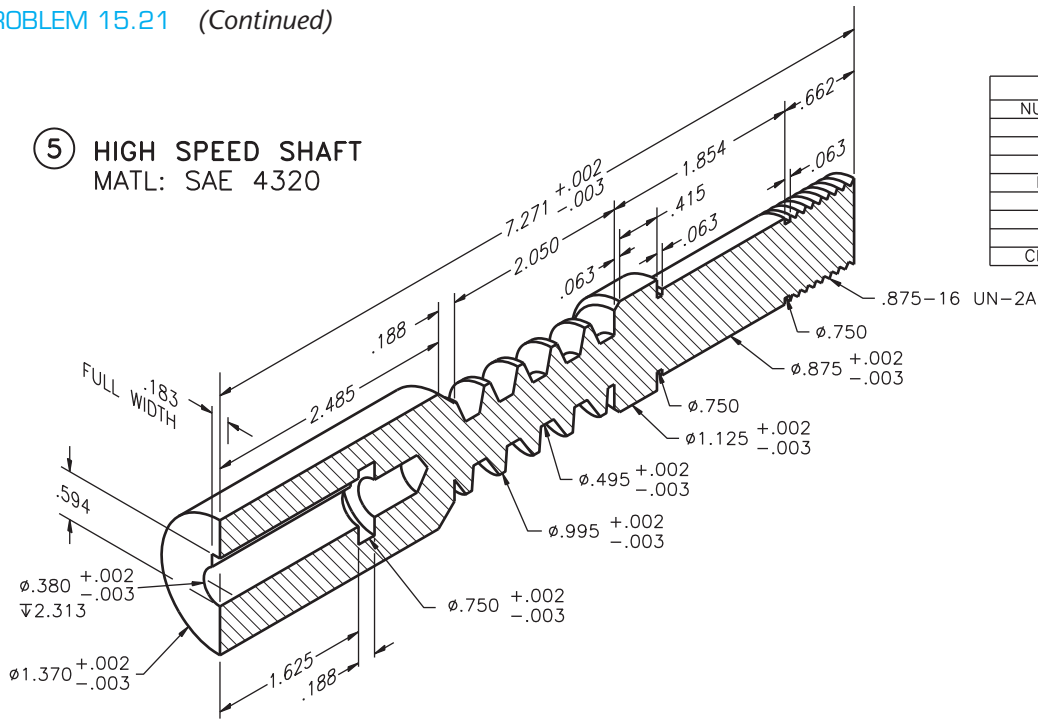
④ MOTOR ADAPTER  
MATL: CI



⑥ SLOW SPEED SHAFT  
MATL: SAE 4320

PROBLEM 15.21 (Continued)

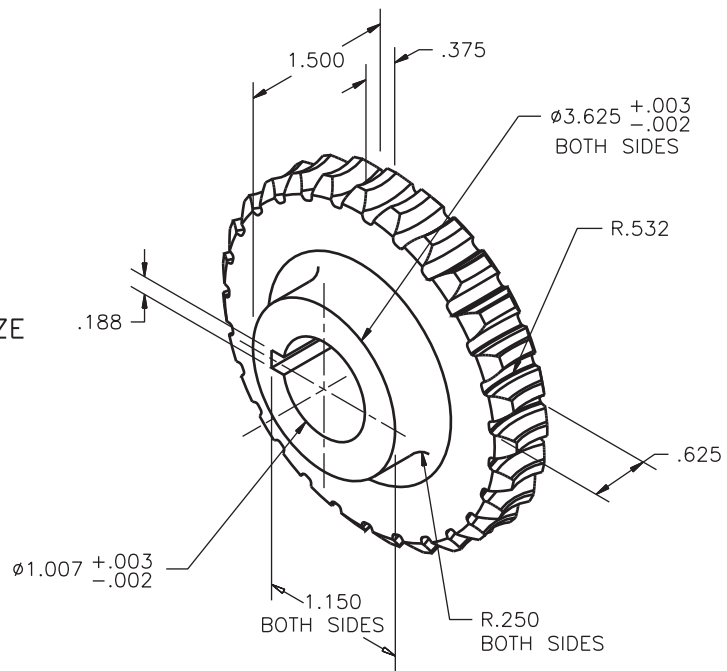
⑤ HIGH SPEED SHAFT  
MATL: SAE 4320



WORM GEAR DATA	
NUMBER OF THREADS	5
AXIAL PITCH	
PRESSURE ANGLE	20°
PITCH DIAMETER	.750
LEAD RIGHT HAND	.300
LEAD ANGLE	169°
ADDENDUM	.125
WHOLE DEPTH	.250
CHORDAL THICKNESS	.163

⑦ WORM GEAR  
MATL: PHOSPHOR BRONZE

SPUR GEAR DATA	
DIAMETRAL PITCH	8
NUMBER OF TEETH	27
PRESSURE ANGLE	20°
PITCH DIAMETER	3.375
BASE CIRCLE DIAMETER	3.6187
CIRCULAR PITCH	.3927
CIRCULAR THICKNESS	.1964
ROOT DIAMETER	3.125



© Cengage Learning 2012

**PROBLEM 15.22 Working drawing (in.)**

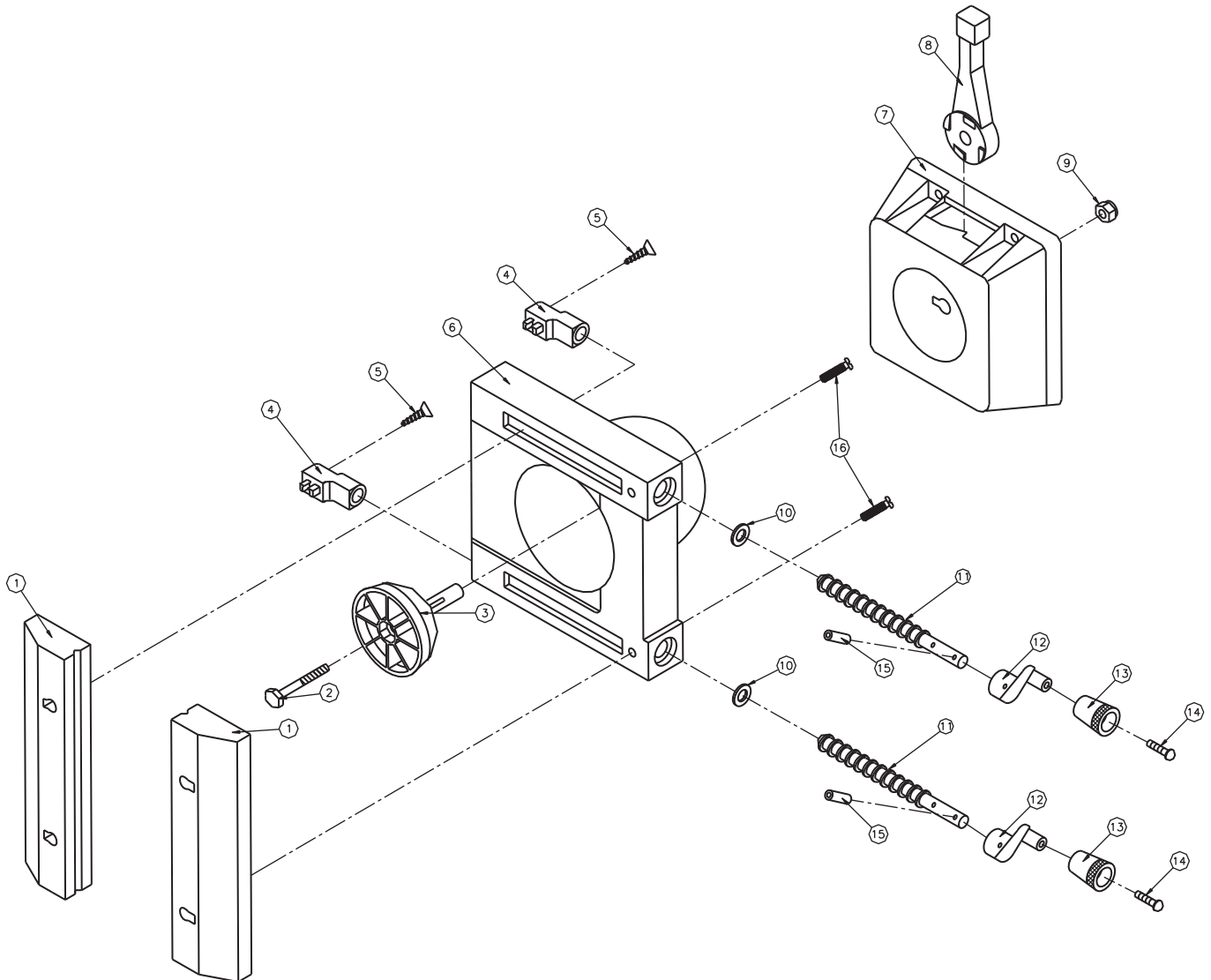
Assembly Name: Table Vise

SPECIFIC INSTRUCTIONS: Prepare a complete set of working drawings with one detail drawing per sheet and the assembly and parts list on another sheet. When preparing the assembly drawing, use separate balloons for each part

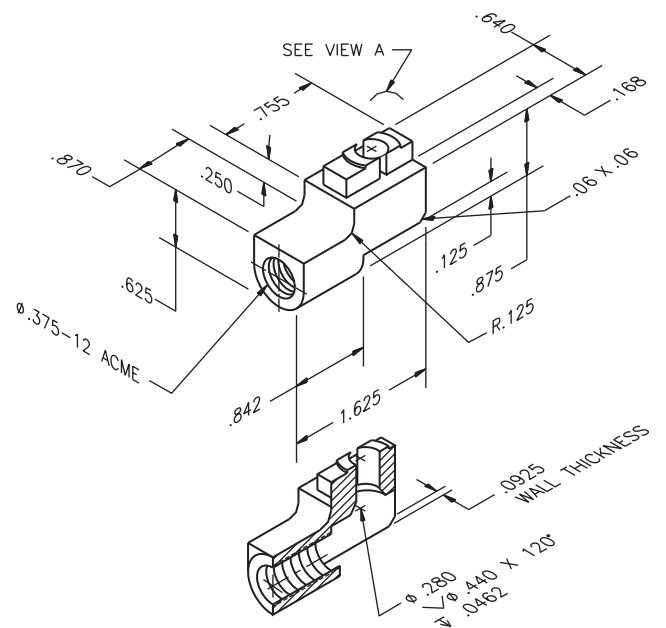
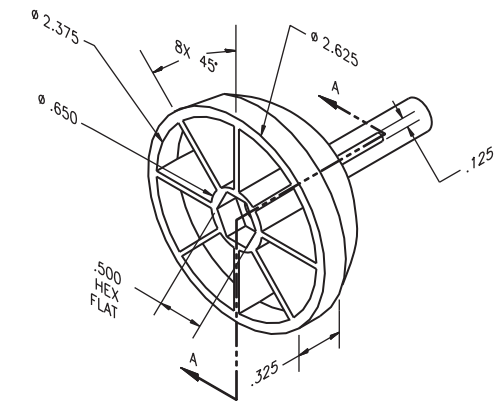
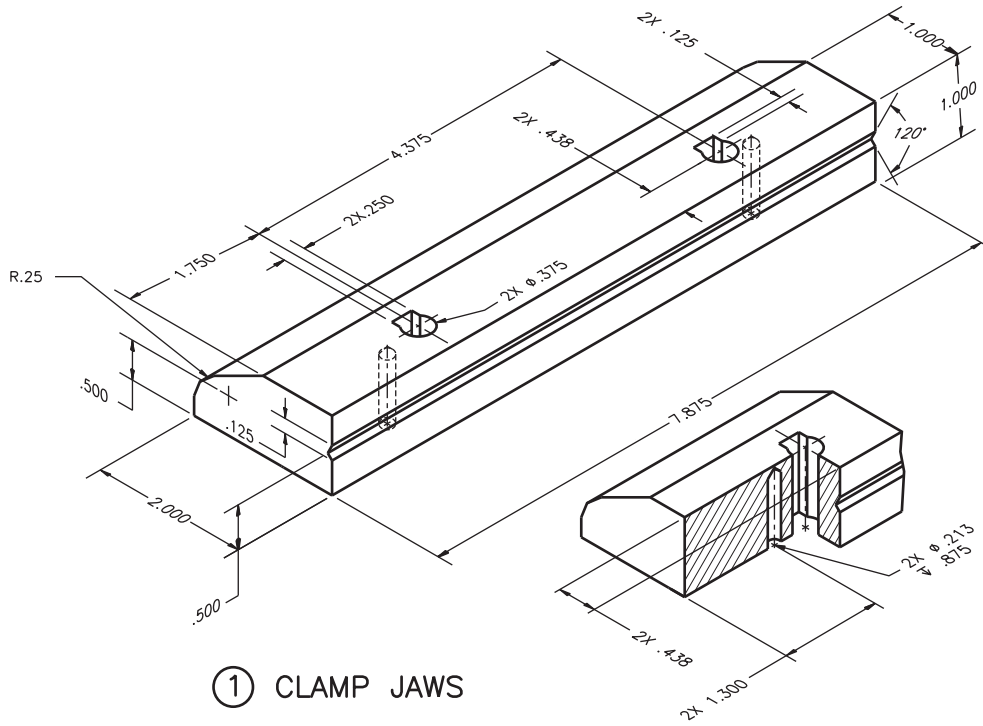
in each view or use only one balloon in the view that most clearly identifies the part. This is an engineering prototype project. Errors are likely in this problem. Verify dimensions during assembly. Establish tolerances between mating parts.

**PARTS LIST**

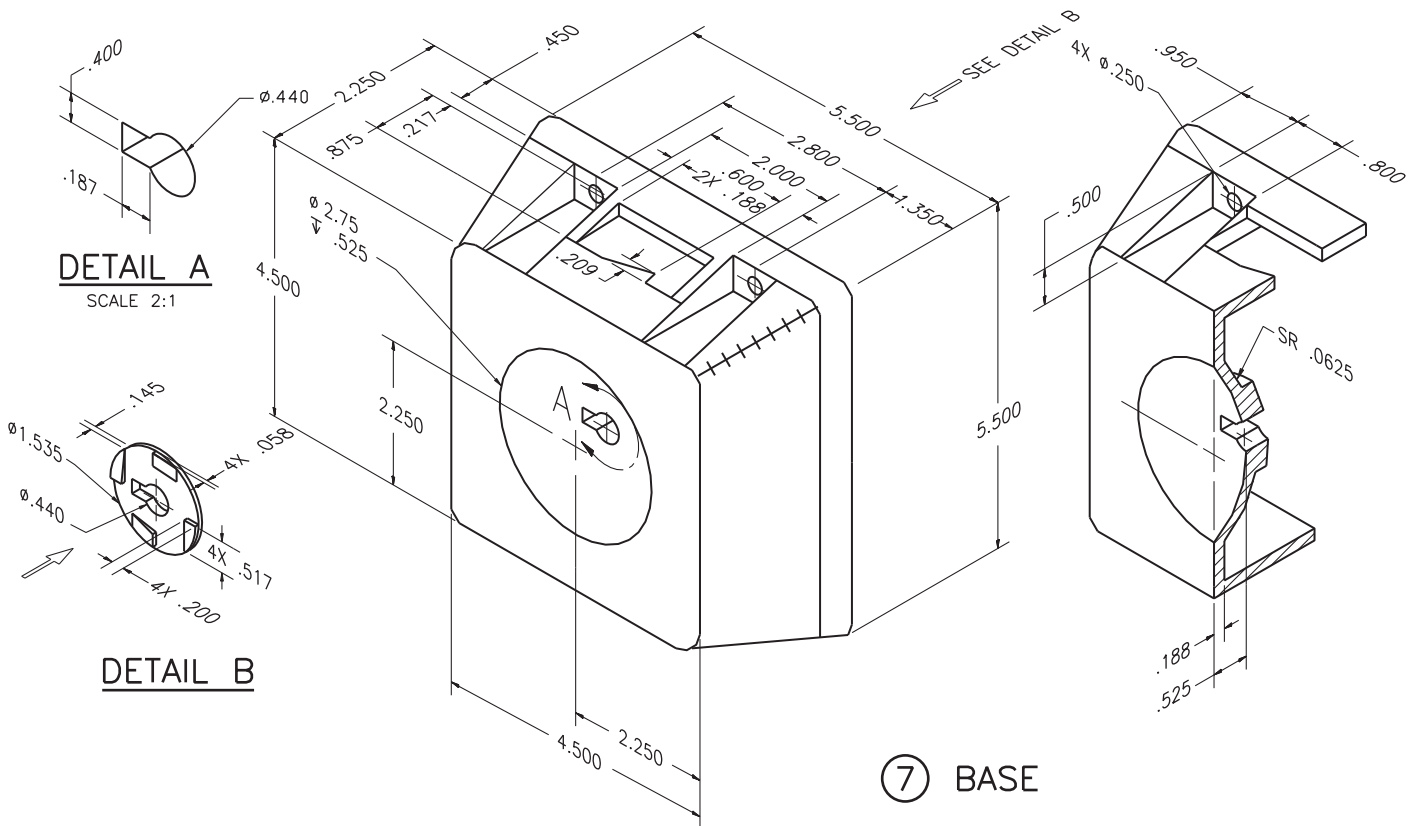
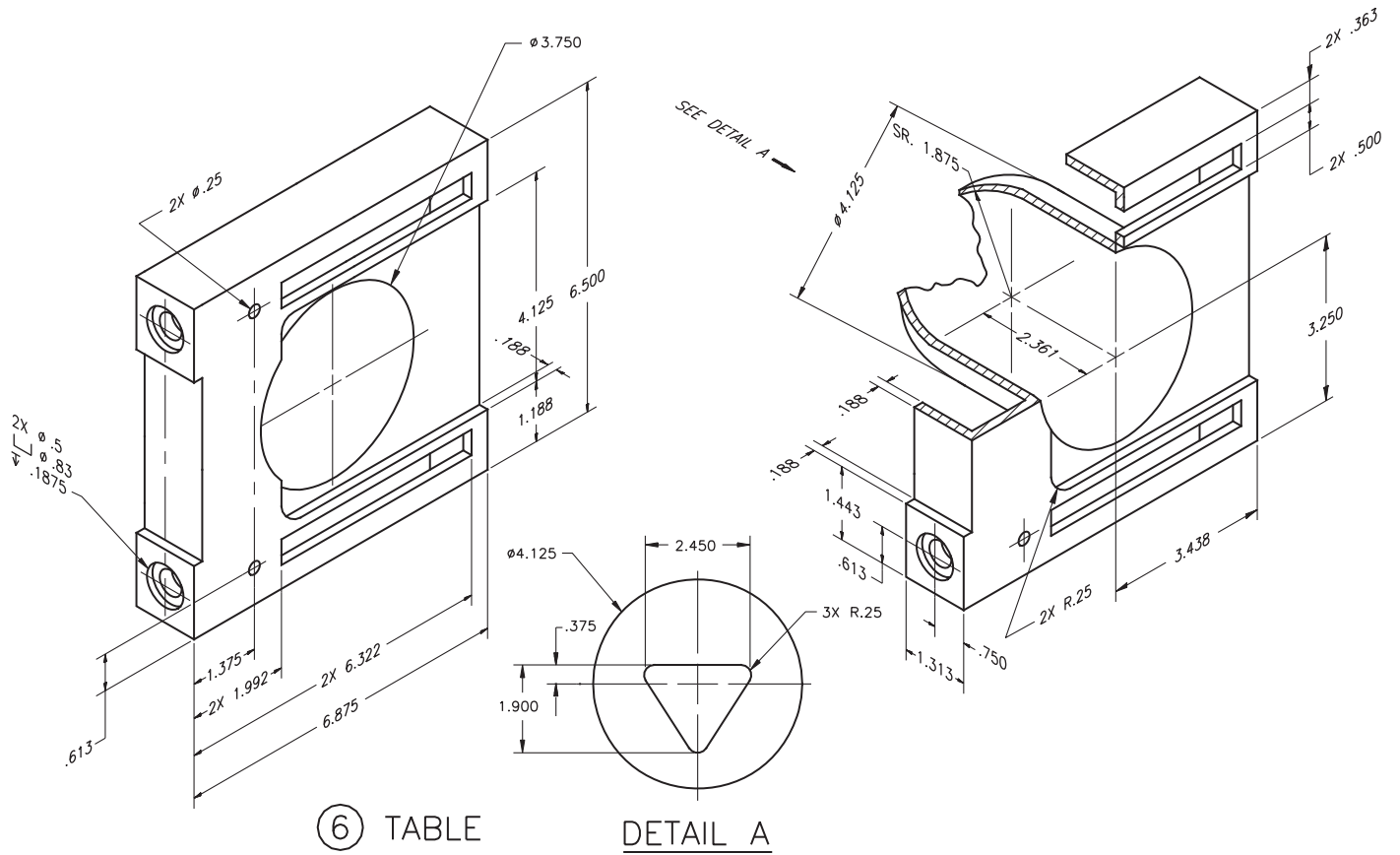
KEY	QTY	DESCRIPTION	KEY	QTY	DESCRIPTION
1	2	CLAMP JAWS	9	1	1/4-28UNF NYLOCK NUT
2	1	1/4 -28UNF X 2" LG HEX HD MACH. SCREW	10	2	3/8 FLAT WASHER
3	1	PIVOT	11	2	ADJUSTING ROD
4	2	SCREW ADJUSTER	12	2	ADJUSTING ROD HANDLE
5	2	1/4-28UNF X 1" LG STANDARD SLOT FLAT COUNTERSUNK HD CAP SCREW	13	2	ADJUSTING HANDLE KNOB
6	1	TABLE	14	2	8-32UNC X 5/8" LG SLOTTED ROUND HD. MACHINE SCREW
7	1	BASE	15	2	1/8 SPRING PIN
8	1	LOCKING HANDLE	16	2	1/4-28UNF X 1" LG STANDARD SLOT PAN HEAD MACHINE SCREW



PROBLEM 15.22 (Continued)

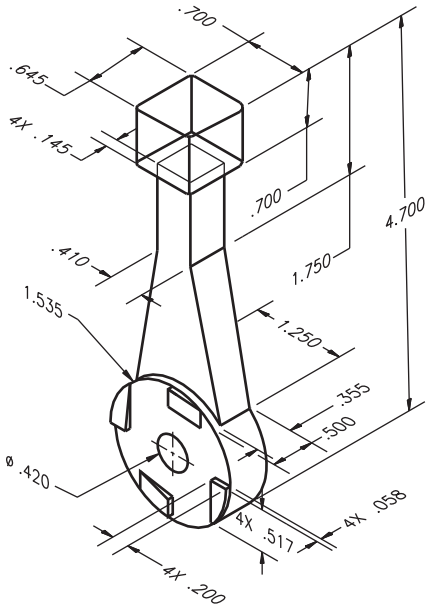


PROBLEM 15.22 (Continued)

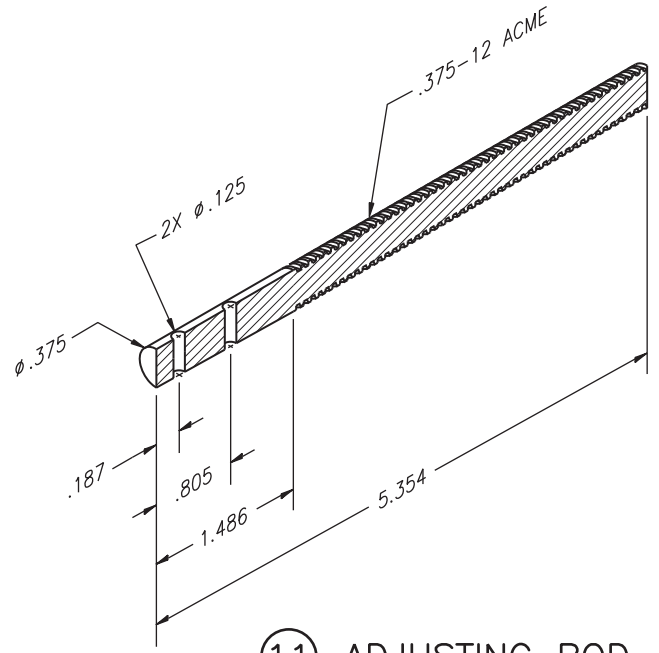




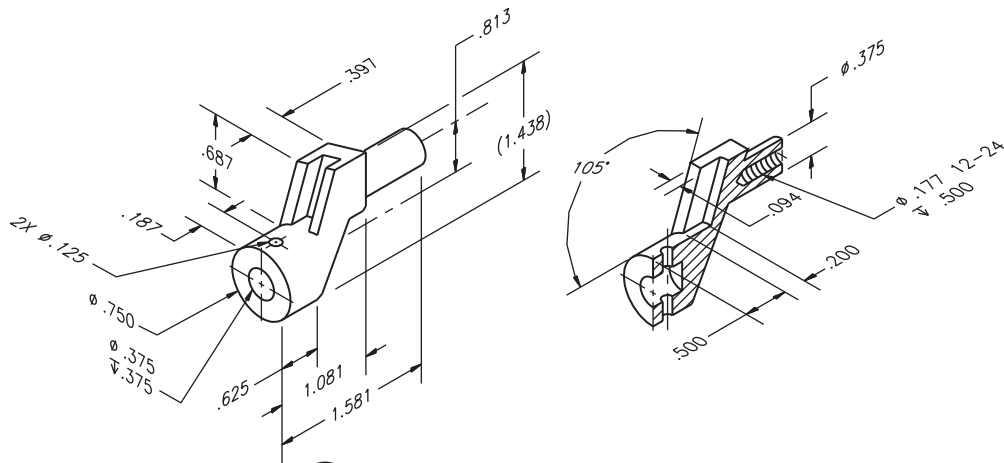
PROBLEM 15.22 (Continued)



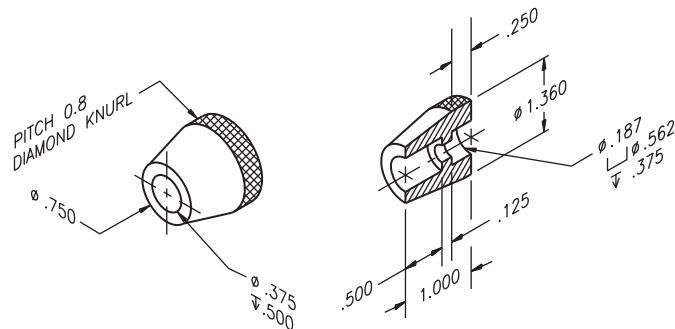
⑧ LOCKING HANDLE



⑪ ADJUSTING ROD



⑫ ADJUSTING ROD HANDLE



⑬ ADJUSTING HANDLE KNOB

© Cengage Learning 2012

## Advanced Team Design Problems

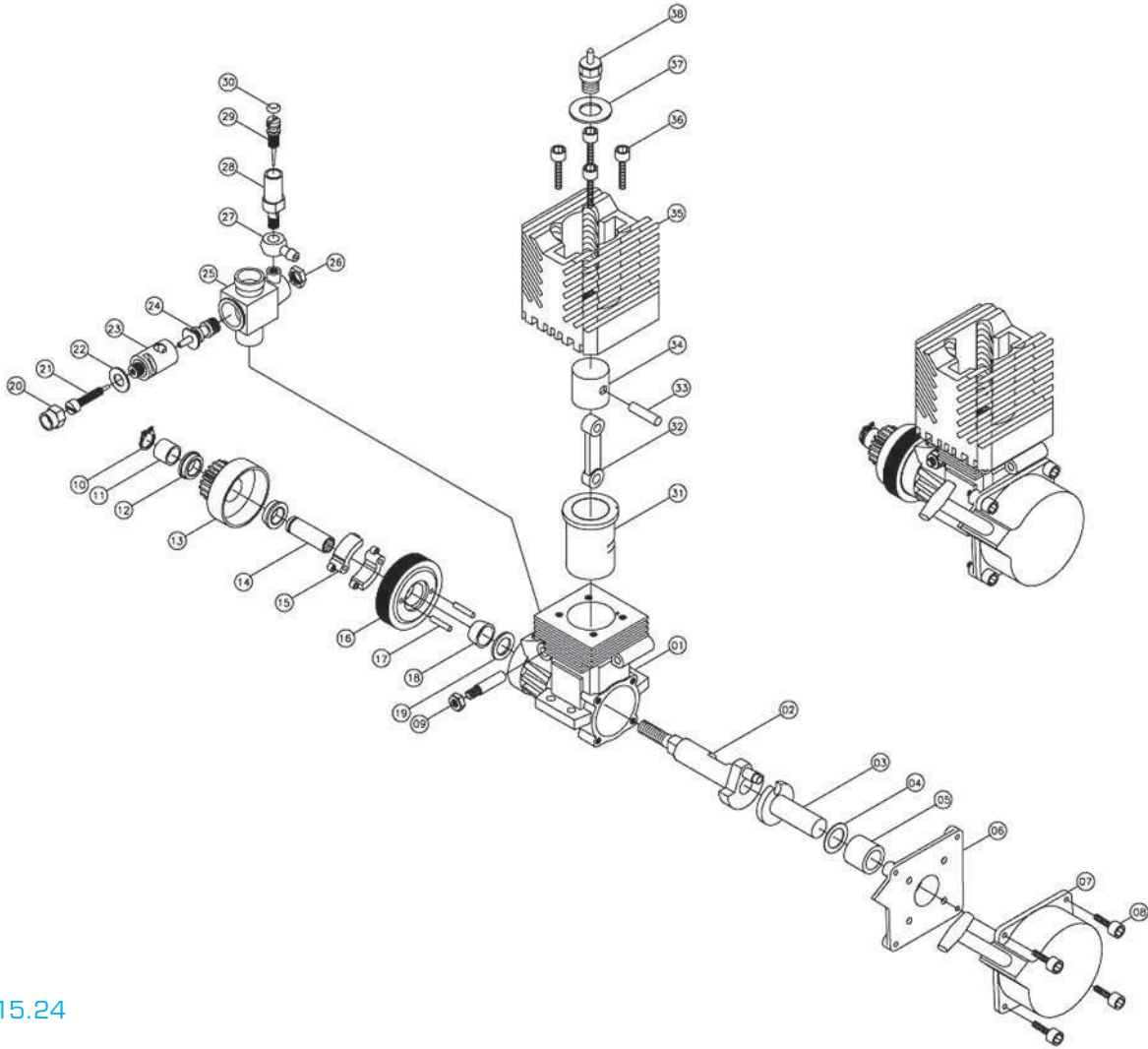
### Part 2: Problems 15.23 and 15.24



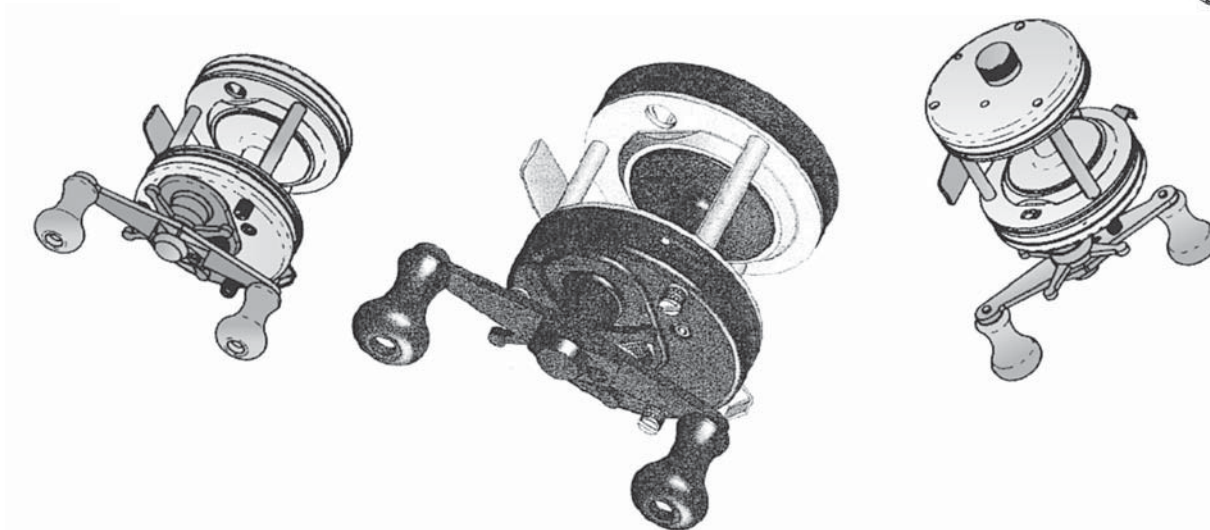
To access the Chapter 15 problems, go to the Student CD, select **Chapter Tests and**

#### PROBLEM 15.23

**Problems and Chapter 15**, and then open the problem of your choice or as assigned by your instructor. Solve the problems using the instructions provided on the CD, unless otherwise specified by your instructor.

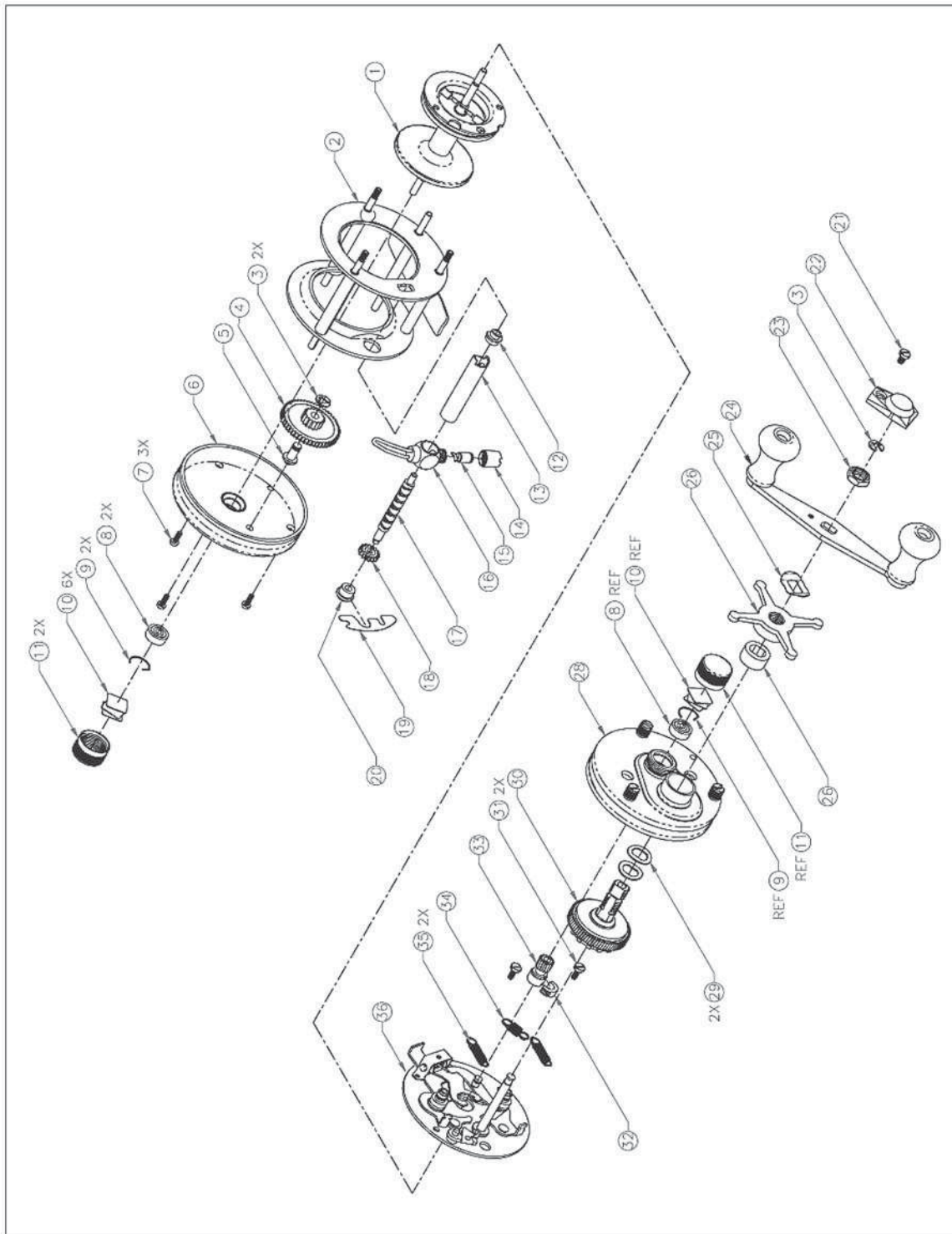


#### PROBLEM 15.24



© Cengage Learning 2012

PROBLEM 15.24 (Continued)



ASSEMBLY FULLY EXPLODED

**Part 3: Problems 15.25 Through 15.27****PROBLEM 15.25 Engineering changes**

Your instructor will use your complete set of working drawings to prepare a series of engineering changes. The complete set of working drawings for your assigned or selected problem must be completed, checked by your instructor, and edited as needed for final grading before doing engineering changes. Confirm the submittal process with your instructor.

**PROBLEM 15.26 Engineering design problem**

If you were assigned or selected a problem that contained errors, you can submit the correct completed problem to the publisher of this textbook for possible use in future editions. Your submittal should include the revised fully dimensioned isometric drawings or dimensioned 3-D models and the correct set of 2-D working drawings that you completed for your project. In addition, submit your name and contact information; include a brief biography of yourself for use in an acknowledgment if your work is selected for use in the next edition of this textbook. Make a statement granting permission for the publisher to use your work. Send the electronic files to:

Delmar  
Care of author of Engineering Drawing and Design  
Executive Woods  
5 Maxwell Drive  
Clifton Park, NY 12065

**PROBLEM 15.27 Engineering design problem**

Find a product of your choice that contains at least three or more parts. You must be able to disassemble the product without destroying. This is your responsibility. Use measuring tools such as calipers and micrometers to establish dimensions. Establish fits between mating parts. Create a set of working drawings for the product, including a detail drawing of each part to be manufactured on separate sheets. Create an assembly drawing with parts list. Include any purchase parts in the parts list. Create fully dimensioned isometric drawings or dimensioned 3-D models for your project. Submit the completed problem to the publisher of this textbook for use in future editions. In addition, submit your name and contact information and include a brief biography of yourself for use in an acknowledgment if your work is selected for use in the next edition

of this textbook. Make a statement granting permission for the publisher to use your work. Send the electronic files to:

Delmar  
Care of author of Engineering Drawing and Design  
Executive Woods  
5 Maxwell Drive  
Clifton Park, NY 12065

**Part 4: Problem 15.28****PROBLEM 15.28 Engineering design problem**

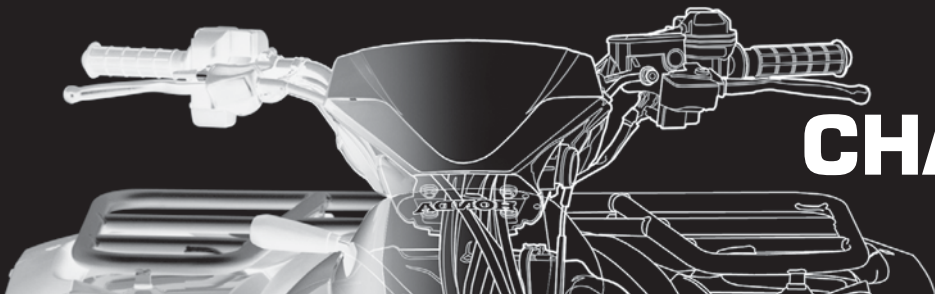
To access the Chapter 15 problems, go to the Student CD, select **Chapter Tests and Problems** and **Chapter 15**, and then open the problem of your choice or as assigned by your instructor. Solve the problems using the instructions provided on the CD, unless otherwise specified by your instructor.

Using the drawings of the current adjustable wrench and the discussion provided in the Engineering Design Application in Chapter 1 of this textbook, redesign the adjustable wrench with an ogee curved handle as described. Create the following:

- A 3-D model of new ogee curved handle adjustable wrench.
- 2-D detail drawings of new ogee curved handle adjustable wrench.
- A 2-D assembly parts drawing and parts list of new ogee curved handle adjustable wrench.
- Catalog copy for marketing the new ogee curved handle adjustable wrench.

**Math Problems****Part 5: Problems 15.29 Through 15.34**

To access the Chapter 15 problems, go to the Student CD, select **Chapter Tests and Problems** and **Chapter 15**, and then open the math problem of your choice or as assigned by your instructor. Solve the problems using the instructions provided on the CD, unless otherwise specified by your instructor.



# CHAPTER 16

## Mechanisms: Linkages, Cams, Gears, and Bearings

### LEARNING OBJECTIVES

After completing this chapter, you will:

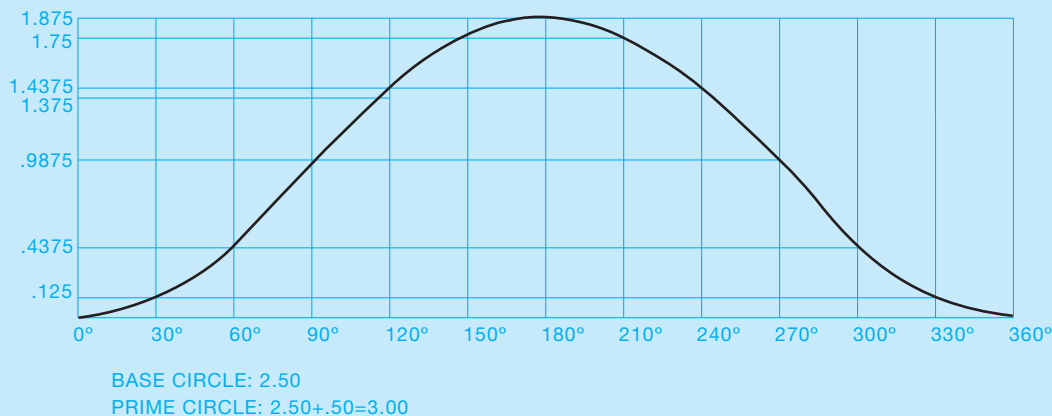
- Draw linkage diagrams.
- Create cam displacement diagrams.
- Design cam profile drawings from previously drawn cam displacement diagrams.
- Make detail gear drawings using simplified representations and gear data charts.
- Establish unknown data for gear trains.
- Calculate bearing information from specifications.
- Design a complete gear reducer from engineering data and sketches.

### THE ENGINEERING DESIGN APPLICATION

Your latest assignment is to produce a drawing of an in-line follower plate cam profile for a product being manufactured. The engineer has provided the specifications in a cam displacement diagram (see Figure 16.1). Your manufacturing department is using a computer-aided manufacturing (CAM) system and needs a CADD drawing from which the required tooling paths can be established.

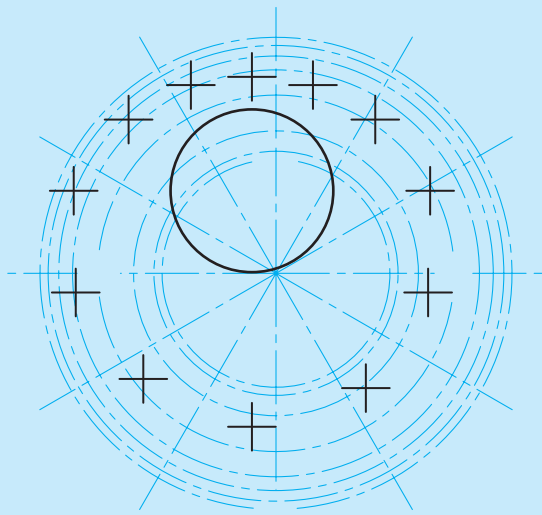
Using a CADD system, the process is usually easy and completely accurate. Using appropriate techniques, you

find and draw the base circle and the prime circle. Next, you create a circular pattern, or array of lines extending outward from the center of the circle at 30° increments (see Figure 16.2). Finally, you use offsets of the base circle as indicated by the engineer's diagram to find all the specified control points. Using a spline curve that intersects each of these points, you create a profile drawing to generate tooling paths for the CAM system (see Figure 16.3).

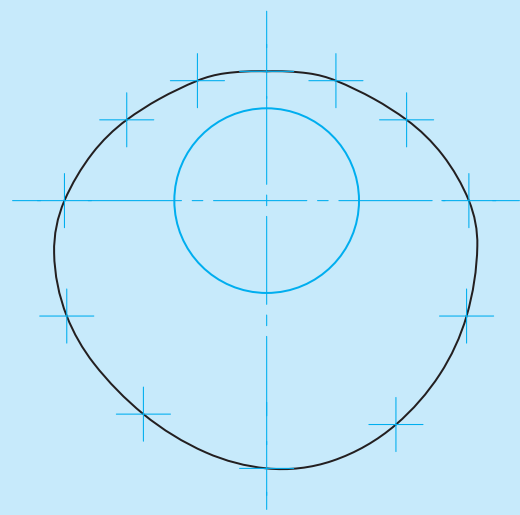


**FIGURE 16.1** Engineer's cam displacement diagram.

© Cengage Learning 2012



**FIGURE 16.2** Construction of a plate cam profile for computer-aided manufacturing (CAM).



**FIGURE 16.3** The plate cam profile used to generate the CAM tool path.

## MECHANISM

A **mechanism** is an arrangement of parts in a mechanical device or machine. This chapter deals with the design and drafting of elements of a mechanism, including linkages, cams, gears, and bearings. The study of mechanisms is part of the physical sciences known as **mechanics**. Mechanics includes statics and dynamics. **Statics** is the study of physics dealing with nonmoving objects acting as weight. **Dynamics** is the branch of physics that studies the motion of objects and the effects of the forces that cause motion. Dynamics is divided into two categories: kinetics and kinematics. **Kinetics** is an element of physics that deals with the effects of forces that cause motion in mechanisms. The linkages, cams, and gears discussed in this chapter relate to the branch of physics known as **kinematics**, or the study of mechanisms without reference to the forces that cause the movement.

### Mechanisms in Daily Lives

Mechanisms play an important role in daily activities. Every modern convenience—from the toaster used to make part of your breakfast to the automobile that you drive to school or work—is made up of one or more mechanisms. For example, the car is a complex combination of mechanisms that includes all of the types of mechanisms discussed in this chapter.

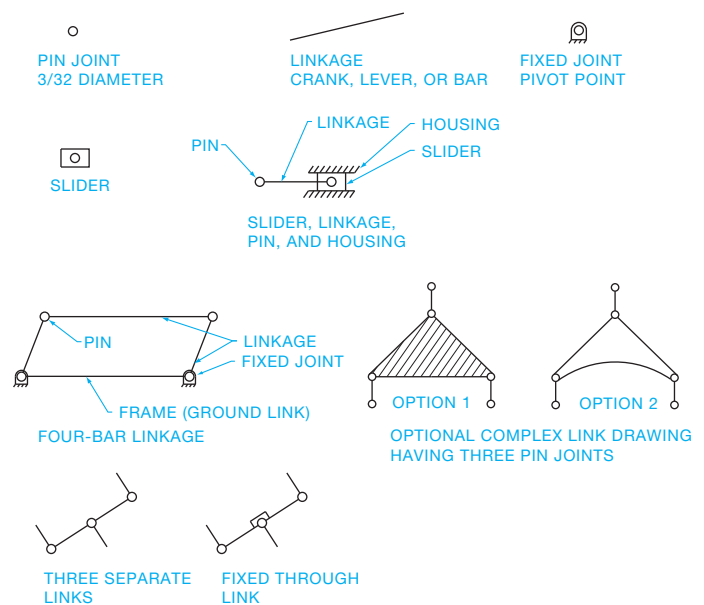
## LINKAGES

The elements of any mechanism are referred to as **links**. Links or linkages can be defined as any rigid element of the mechanism. In actual practice all of the mechanism components are links, including levers, bars, sliders, cams, and gears. The frame of the device is even considered a fixed link and is an important

part of the mechanism. The first part of this chapter separates the types of linkages that deal primarily with motion caused by levers, rockers, cranks, and sliders.

## LINKAGE SYMBOLS

One benefit of designing linkage mechanisms is that the drawings are often in the form of schematic or single-line representations. After the complete design is created using these schematic drawings, the designer or drafter can go to work creating the actual components in relation to the schematic design. Schematic drawings have only a few basic components as shown in Figure 16.4.



**FIGURE 16.4** Linkage diagram symbols. © Cengage Learning 2012

The symbols are drawn proportional to the examples. The actual scale depends on the size of the drawing. Typical sizes are shown for most applications in this chapter. You can see here how easy it would be to develop a CADD symbols library for use when drawing these mechanisms.

## TYPES OF LINKAGES

There are many different combinations of linkage mechanisms. These devices are divided into a few basic elements. The illustrations in this discussion show you the linkage mechanism using a simple pictorial drawing of the actual device and the related schematic representation.

### Crank Mechanism

A **crank** is a link that makes a complete revolution around a fixed point. When working with the crank, keep in mind that the crank link is a fixed distance equal to the radius of the movement as shown in Figure 16.5.

### Lever, or Rocker, Mechanism

A **lever**, or **rocker**, is a link that moves back and forth or oscillates through a given angle as illustrated in Figure 16.6.

### Rocker Arm Mechanism

A **rocker arm** is different from the rocker previously discussed because it has a pivot point near the center and oscillates through a given angle as shown in Figure 16.7. Notice the symbol for a fixed link. This symbol is used to indicate that the link between points A and B remains rigid.

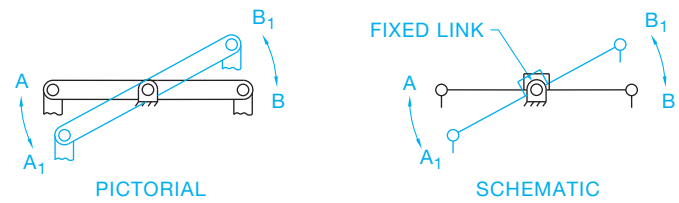


FIGURE 16.7 Rocker arm and fixed link symbol. © Cengage Learning 2012

### Bell Crank Mechanism

Another form of a rocker arm is the **bell crank**. The bell crank is a more complex form of the linkage mechanism. The bell crank drawing shown in Figure 16.8 is a three-joint mechanism where the distances between points A, B, and C are fixed. Other bell crank designs may contain more than three pivot points, depending on the design requirements. Notice that the schematic representation in Figure 16.8 shows two alternatives. Consult with your instructor or employer on the technique to use.

### Four-Bar Linkage

The most commonly used linkage mechanism is called a **four-bar linkage**. There are many alternate designs of the four-bar linkage, but the basic form has four links, one of which is the ground link or machine frame. One of the rotating links is called the **driver** or **crank**, and the other is called the **follower** or **rocker**. The link connected between the crank and rocker is called the **connecting rod** or **coupler**. The two pivoted links both rotate through 360°, or one rotates while the other oscillates, or they both oscillate, depending on the lengths and arrangement of the links (see Figure 16.9).

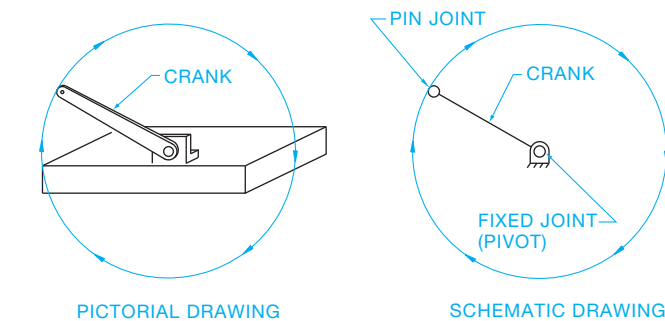


FIGURE 16.5 Crank mechanism. © Cengage Learning 2012

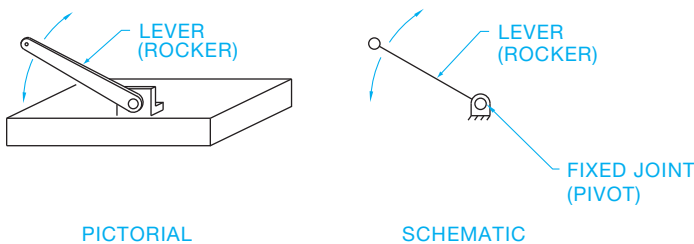


FIGURE 16.6 Lever or rocker mechanism. © Cengage Learning 2012

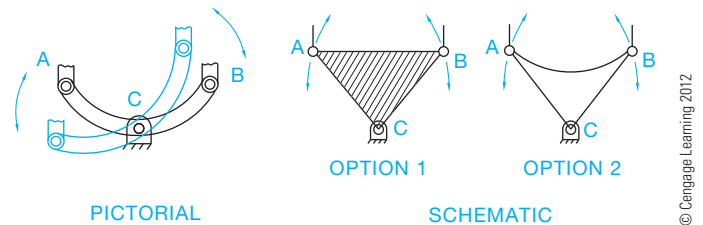


FIGURE 16.8 Bell crank mechanism.

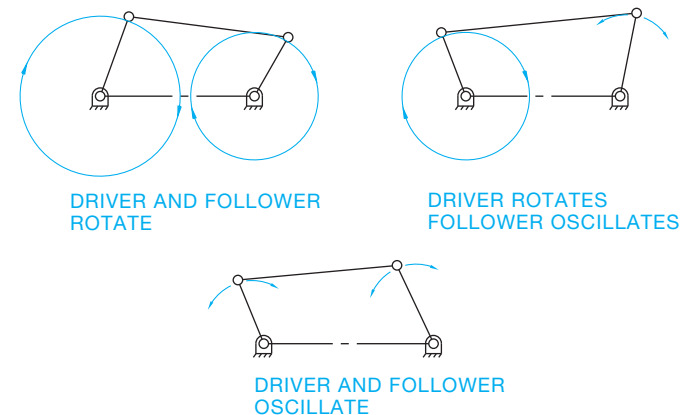


FIGURE 16.9 Four-bar linkage movements.

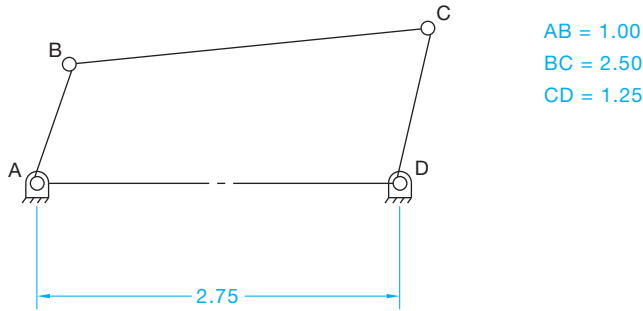


FIGURE 16.10 Four-bar linkage example.

Normally when determining the function of a four-bar linkage, the designer must show the extreme right and extreme left positions. If the crank rotates and the rocker oscillates, then the angle of oscillation can be established with this technique. For example, determine the angle of oscillation for rocker link CD in the four-bar linkage shown in Figure 16.10. Lines and symbols on layers of different color are often helpful in showing the various positions for a clear analysis of the operation. Follow these steps:

- STEP 1 AND STEP 2** Draw a circle through point B with the center at A and a circle through C with the center at D. Determine the extreme right position of link CD by adding the length of links AB and BC ( $1.00 + 2.50 = 3.50$ ). This puts AB and BC in a straight line as shown in Figure 16.11.
- STEP 3** Establish the extreme left position of link CD by subtracting the length of link AB from BC ( $2.50 - 1.00 = 1.50$ ). This places link AB and BC in a straight line to the left as shown in Figure 16.12.
- STEP 4** Determine the angle between the extreme right and extreme left positions of CD as shown in Figure 16.13.

### Slider Crank Mechanism

A **slider crank** is a linkage mechanism that is commonly used in machines such as engine pistons, pumps, and clamping devices where a straight line motion is required. Figure 16.14 shows the type of slider design used to move a piston back and forth in a straight line. The distance the slider travels from the

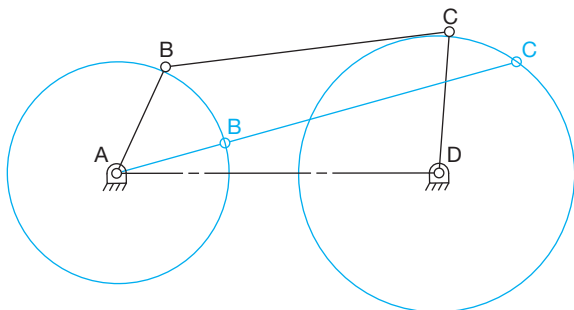


FIGURE 16.11 Steps 1 and 2: Four-bar linkage solution.

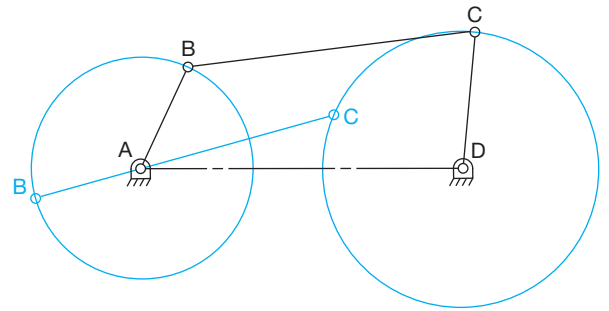


FIGURE 16.12 Step 3: Four-bar linkage solution, extreme left position.

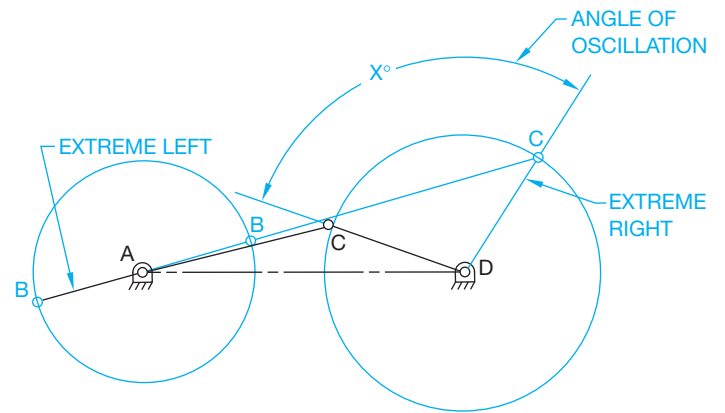


FIGURE 16.13 Step 4: Four-bar linkage solution, extreme right position.

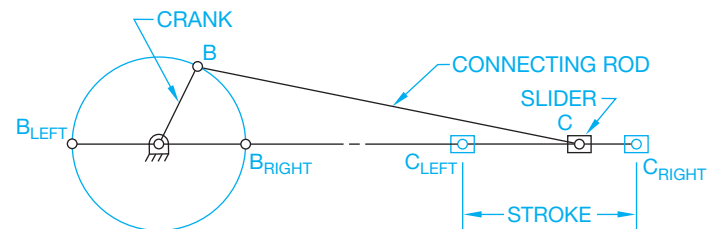
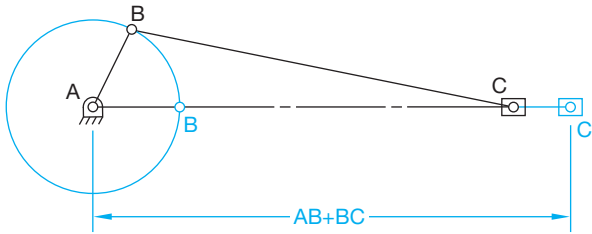


FIGURE 16.14 Slider mechanism. © Cengage Learning 2012

extreme left to the extreme right position is called the **stroke**. When working with the design of an engine, it is important to establish the piston stroke and diameter. The distance the piston travels is the stroke. A combination of the stroke and piston diameter determines the piston **displacement**. An example is a four-cylinder, 2000 cc engine that has a displacement of 500 cc per piston cylinder. You can graphically show the stroke of a piston if you have an engine with a crank length of 1.25 in. (32 mm) and a connecting rod length of 3.25 in. (82 mm). Determine the length of the piston stroke as follows:

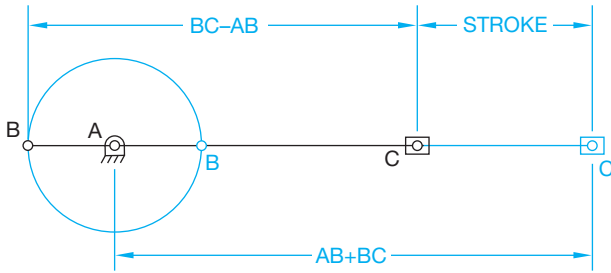
- STEP 1 AND STEP 2** Draw an arc with point A as the center and  $AB = 1.25$  in. (32 mm) as the radius. Show the connecting rod attached to the piston as link BC. Add AB to BC ( $1.25 + 3.25 = 4.50$ ) ( $32 + 82 = 114$  mm). Measure the distance from point A along the centerline through





© Cengage Learning 2012

FIGURE 16.15 Steps 1 and 2: Slider mechanism, extreme right position.



© Cengage Learning 2012

FIGURE 16.16 Step 3: Slider mechanism, extreme left position.

A and C. This establishes the extreme right position as shown in Figure 16.15.

**STEP 3** Subtract AB from BC ( $3.25 - 1.25 = 2.00$ )( $82 - 32 = 50$  mm). Measure from point A along the centerline through A and C. This establishes the extreme left position of point C. Measure the distance between the extreme left and right positions to determine the stroke as shown in Figure 16.16.

### Combination Four-Bar Linkage and Slider Mechanism

The design of linkage mechanisms is only limited by the imagination of the designer. There can be any variety of combinations. In the previous examples, the extreme right and left positions were established to determine the function of the mechanism. However, in many situations the designer must establish several positions to analyze the movement completely. Figure 16.17 shows an example. This mechanism is a combination four-bar linkage and slider. The objective is to determine the path of point P as the link AB rotates  $360^\circ$ . To solve a problem of this type effectively, it is necessary to plot the path of point P by moving link AB a minimum of  $30^\circ$  increments. Additional increments such as at  $15^\circ$  each provide additional accuracy. This is best accomplished for visualization if you use a different color or line type for each position. Careful labeling of each position is important, because it can become confusing.

**STEP 1** Draw a circle through point B with A as the center. Point B must remain on this circle through each movement. Draw an arc through point C with D as

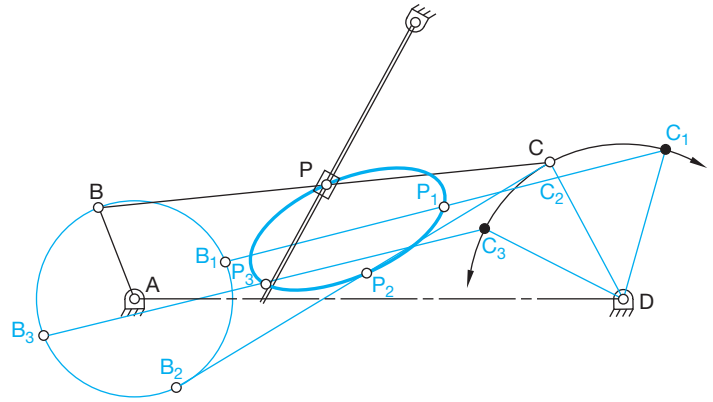


FIGURE 16.17 Steps 1, 2, and 3: Solution to four-bar linkage and slider mechanism example. © Cengage Learning 2012

the center. Point C must remain on this arc through each movement of the mechanism.

**STEP 2** Although  $30^\circ$  increments are recommended, this example uses  $90^\circ$  increments for convenience and clarity. Move point B clockwise to  $B_1$  (see Figure 16.17). From  $B_1$  draw an arc with a radius equal to BC until it intersects arc CD, establishing point  $C_1$ . Draw link  $B_1C_1$ . Measure distance BP and transfer it to link  $B_1C_1$ , establishing point  $P_1$ .

**STEP 3** Follow the same procedure for positions  $B_2$  and  $B_3$ . This determines the path of coupler point P at positions  $P_2$  and  $P_3$ .



### 3-D Animation

To see and operate the 3-D animation of a backhoe linkage mechanism, go to the Student CD, select **Supplemental Material, Chapter 16**, and then **3-D Animation of Backhoe Linkage Mechanism**. Animation courtesy of Parametric Technology Corporation.

### CAM DESIGN

A **cam** is a rotating mechanism that is used to convert rotary motion into a corresponding straight motion. The **timing** involved in the rotary motion is often the main design element of the cam. Timing is the regulation of occurrence, rate, or coordination of a mechanism, such as the synchronization of the rotation of a cam to achieve a desired effect. The timing of a cam occurs in the mechanism in one complete  $360^\circ$  revolution. For example, a cam can be designed to make a follower rise a given amount in a given degree of rotation and then remain constant for an additional period of rotation, which is referred to as **dwell**, and finally fall back to the beginning in the last degree of rotation. The total movement of the cam follower happens in

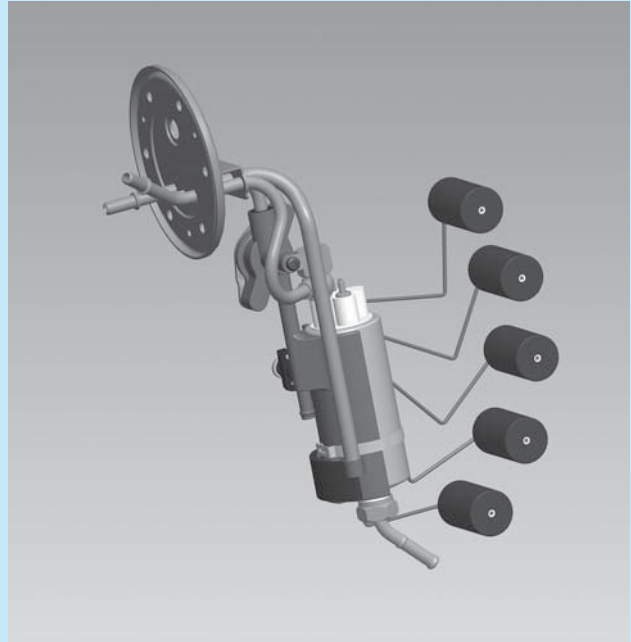
### MECHANISM DESIGN

CADD is a natural in mechanism design and drafting. Mechanism design drawings are created using symbols and techniques that are easily adapted to CADD systems. You will see later that linkage mechanisms, for example, are often designed by displaying the mechanism in several different positions. Using CADD to do this allows you to place each different position of movement on a separate layer and in a different color. Any one or more layers can be turned on or off at your convenience to evaluate the function of the mechanism. In addition, the CADD system is much faster and more accurate than manual design and drafting methods.

Computer programs are available to make the design and drafting of mechanisms easy. For example, some programs can be used to simulate the movement of linkage mechanisms. The illustrations in this chapter were created using a CADD system.

Using CADD in linkage design allows you to establish a series of positions for the mechanism quickly and accurately. After you determine the first position, use commands such as COPY and ROTATE to place the linkages in alternate positions. You can even set up a continuous slide show with each position of the mechanism as a screen display in the slide show. The term **slide show** refers to screen displays that are sequenced in a specific order and for a given period of time. If you allow the slide show to run fast, the viewer gets a good understanding

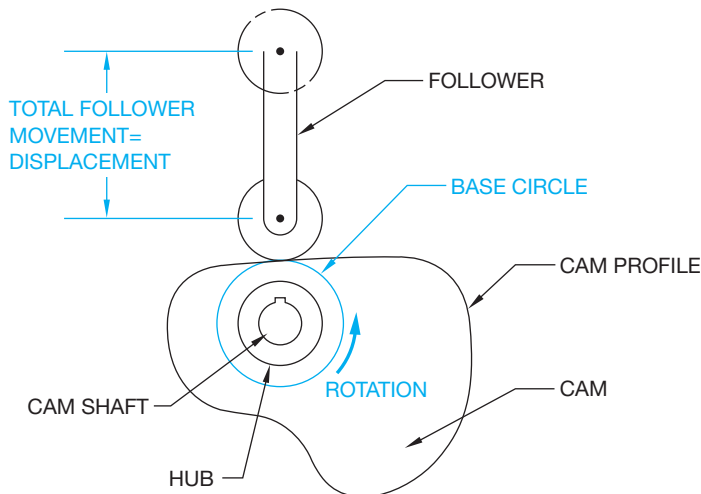
and display of the mechanism in action. This type of a CADD display can be established in 2-D, or in 3-D as shown in Figure 16.18.



Courtesy Synerject North America, Newport News, Virginia

**FIGURE 16.18** Linkage mechanism designed with 3-D CADD showing a fuel delivery module with a float at various positions between low fuel and full.

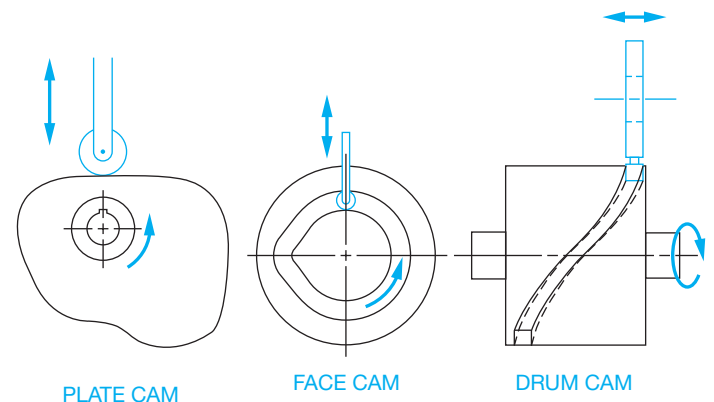
one 360° rotation of the cam. This movement is referred to as the displacement. Cams are generally in the shape of irregular plates, grooved plates, or grooved cylinders. The basic components of the cam mechanism are shown in Figure 16.19.



**FIGURE 16.19** Elements of a cam mechanism. © Cengage Learning 2012

### Cam Types

There are three basic types of cams: the plate cam, face cam, and drum cam (see Figure 16.20). The plate cam is the most commonly used type of cam.



**FIGURE 16.20** Types of cam mechanisms. © Cengage Learning 2012

## Cam Followers

There are several types of **cam followers**. A cam follower is a specialized type of device designed to follow movement. The type of cam follower used depends on the application. The most common type of follower is the roller follower. The **roller follower** works well at high speeds, reduces friction and heat, and keeps wear to a minimum. The arrangement of the follower in relation to the cam shaft differs, depending on the application. The roller followers shown in Figure 16.21 include the inline follower, where the axis of the follower is in line with the cam shaft; the offset roller follower; and the pivoted follower. The pivoted follower requires spring tension to keep the follower in contact with the cam profile.

Another type of cam follower is the **knife-edged follower** shown in Figure 16.22a. This follower is used for only low-speed and low-force applications. The knife-edged follower has a low resistance to wear but is very responsive and is effectively used in situations that require abrupt changes in the cam profile.

The **flat-faced follower** shown in Figure 16.22b is used in situations in which the cam profile has a steep rise or fall. Designers often offset the axis of the follower. This design causes the follower to rotate while in operation. This rotating action allows the follower surface to wear evenly and last longer.

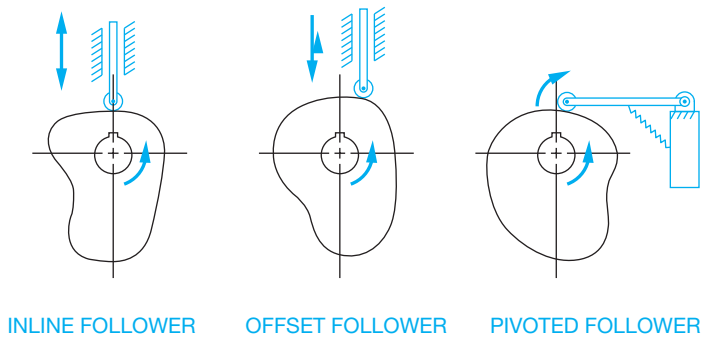


FIGURE 16.21 Types of cam roller followers. © Cengage Learning 2012

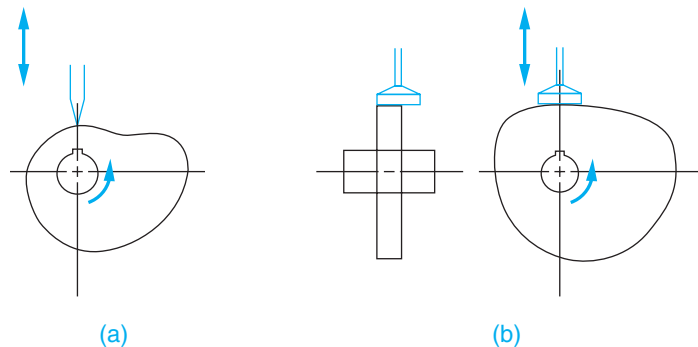


FIGURE 16.22 (a) Knife-edged cam follower. (b) Flat-faced cam follower. © Cengage Learning 2012

## CAM DISPLACEMENT DIAGRAMS

Cams are generally designed to achieve some type or sequence of a timing cycle in the movement of the follower. There are several predetermined types of motion from which cams are designed. These forms of motion can be used alone or in combination, or they can be custom designed to suit specific applications. The following discussion shows you how to set up a cam **displacement diagram** given a specific type of cam motion. The cam displacement diagram is similar to a graph representing the cam profile in a flat pattern of one complete 360° revolution of the cam. The terms associated with the displacement diagram include cycle, **period**, **rise**, **fall**, dwell, and displacement. A complete cam cycle has taken place when the cam rotates 360°. A period of the cam cycle is a segment of follower operation such as rise, dwell, or fall. Rise exists when the cam is rotating and the follower is moving upward. Fall is when the follower is moving downward. Dwell exists when the follower is constant, moving neither up nor down. A dwell is shown in the displacement diagram as a horizontal line for a given increment of degrees.

When developing the cam displacement diagram, the height of the diagram is drawn to scale and is equal to the total follower displacement (see Figure 16.23). The horizontal scale is equal to one cam revolution, or 360°. The horizontal scale can be drawn without scale. Some engineering drafters prefer to make this scale equal to the circumference of the **base circle** or any convenient length. The base circle is an imaginary circle with its center at the center of the cam shaft and its radius tangent to the cam follower at zero position. The horizontal scale is then divided into increments of degrees. Each rise and fall is divided into six increments. For example, if the follower rises 150°, then each increment is  $150^\circ/6 = 25^\circ$ . If the cam falls between 180° and 360°, this represents a total fall of 180° ( $360^\circ - 180^\circ = 180^\circ$ ). The fall increments are  $180^\circ/6 = 30^\circ$  as shown in Figure 16.23.

## Simple Harmonic Motion

**Simple harmonic motion** can be used for high-speed applications if the rise and fall are equal at 180°. Moderate speeds are recommended if the rise and fall are unequal or if there is a dwell in the cycle. This application causes the follower to jump if the speeds are too high.

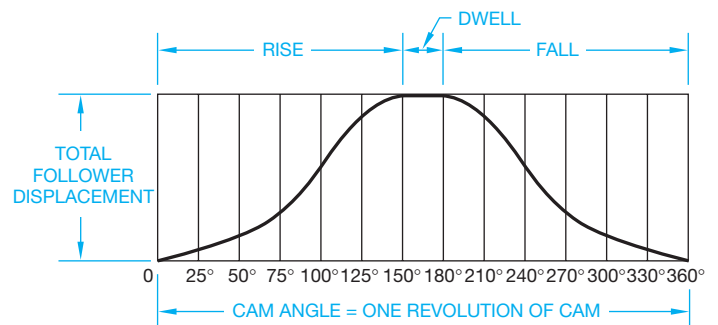
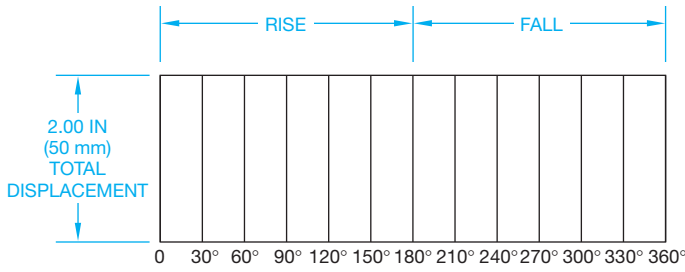
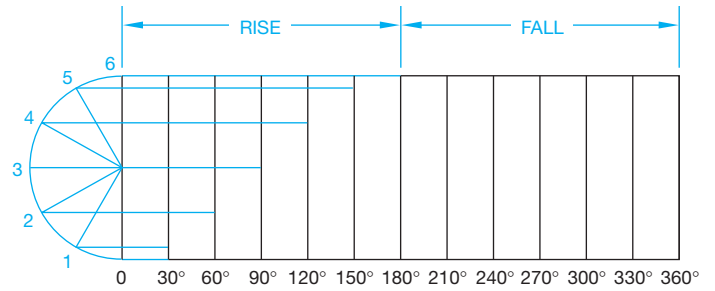


FIGURE 16.23 Cam displacement diagram. © Cengage Learning 2012



**FIGURE 16.24** Step 1: Layout for simple harmonic motion cam displacement diagram. © Cengage Learning 2012



**FIGURE 16.26** Steps 3, 4, and 5: Layout for simple harmonic motion cam displacement diagram. © Cengage Learning 2012

The following steps show you how to draw a cam displacement diagram using simple harmonic motion when the total displacement is 2.00 in. (50 mm) and the cam follower rises the length of the total displacement in 180° and falls back to 0° in 180°.

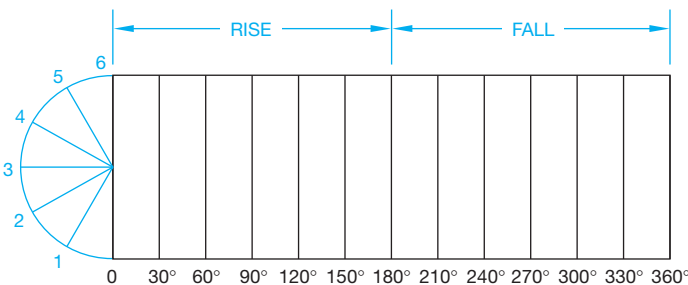
**STEP 1** Draw a rectangle equal in height (vertical scale) to the total displacement of 2.00 in. (50 mm) and equal in length (horizontal scale) to 360°. The horizontal scale should have 6–30° increments for the rise from 0° to 180° and 6–30° increments for the fall from 180° to 360°. The horizontal scale can be any convenient length. Draw a thin vertical line from each horizontal increment as shown in Figure 16.24.

**STEP 2** Draw a half circle at one end of the displacement diagram equal in diameter to the rise of the cam. Divide the half circle into six equal parts as shown in Figure 16.25.

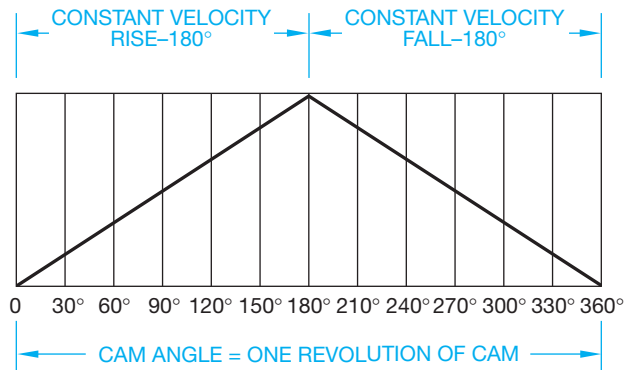
**STEP 3** The cam follower begins its rise at 0°. The rise continues by projecting point 1 on the half circle over to the first 30° increment on the horizontal scale. Continue this process for points 2, 3, 4, 5, and 6 on the half circle, each intersecting the next increment on the horizontal scale.

**STEP 4** Notice the pattern of points created in the preceding step. Connect these points using a curve-fitting command to draw the cam profile.

**STEP 5** Develop the fall profile by projecting the points from the half circle in the reverse order discussed in Step 3 (see Figure 16.26).



**FIGURE 16.25** Step 2: Layout for simple harmonic motion cam displacement diagram. © Cengage Learning 2012



**FIGURE 16.27** Cam displacement diagram for constant velocity motion.

### Constant Velocity Motion

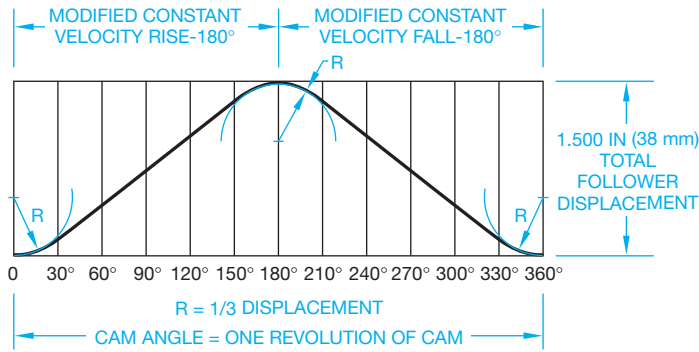
**Constant velocity motion**, also known as **straight line motion**, is used for the feed control of some machine tools when it is required for the follower to rise and fall at a uniform rate. Constant velocity motion is only used at slow speeds because of the abrupt change at the beginning and end of the motion period. The displacement diagram is easy to draw. All you have to do is draw a straight line from the beginning of the rise or fall to the end as shown in Figure 16.27.

### Modified Constant Velocity Motion

**Modified constant velocity motion** is designed to help reduce the abrupt change at the beginning and end of the motion period. This type of motion can be adjusted to accomplish specific results by altering the degree of modification. This is done by placing an arc at the beginning and end of the rise and fall. The radius of the arc depends on the amount of smoothing required, but the radius normally ranges from one-third to full displacement. If the motion is modified to one-third the displacement, then the cam displacement diagram is drawn as shown in Figure 16.28.

### Uniform Accelerated Motion

**Uniform accelerated motion** is designed to reduce the abrupt change at the beginning and end of a period. It is recommended for moderate speeds, especially when associated with a dwell.



**FIGURE 16.28** Cam displacement diagram for modified constant velocity motion. © Cengage Learning 2012

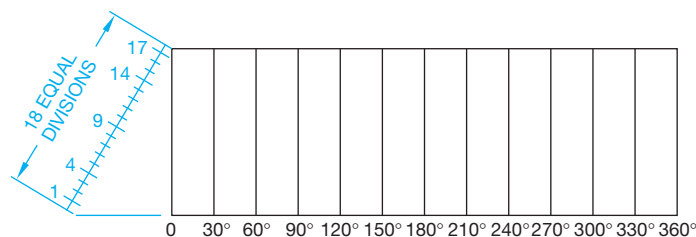
The advantage of this motion is its use when constant acceleration for the first half of the rise and constant deceleration for the second half of the rise are required.

Use the following technique to draw a uniform accelerated motion displacement diagram where the follower rises a total of 2.00 in. (50 mm) in 180° and falls back to 0° in 180°.

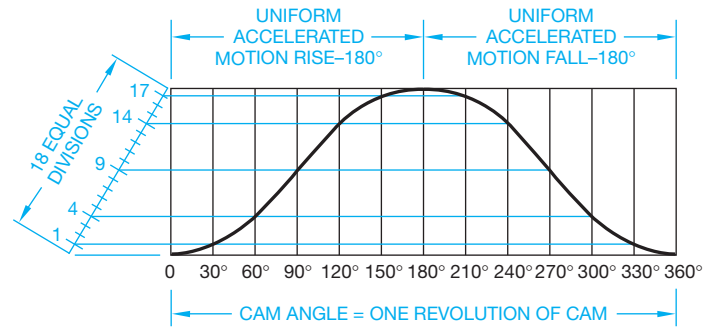
- STEP 1 AND STEP 2** Set up the displacement diagram with the height equal to 2.00 in. (50 mm) total rise and the horizontal scale divided into 30° increments. Keep in mind that the horizontal scale is divided into 30° increments if the rise and fall is 180° each. If the rise, for example, is 120°, then the increments are  $120^\circ/6 = 20^\circ$  each. Set up a scale with 18 equal divisions at one end of the displacement diagram and mark off the first, fourth, ninth, fourteenth, and seventeenth divisions as shown in Figure 16.29.
- STEP 3** Establish the rise by projecting from the first division on the scale to the 30° increment on the diagram and then continue with the fourth division to 60°, the ninth division to 90°, the fourteenth division to 120°, and the seventeenth division to 180°. Continue this same procedure in reverse order to establish the profile of the fall. Connect all of the points to complete the displacement diagram as shown in Figure 16.30.

### Cycloidal Motion

**Cycloidal motion** is the most popular cam profile development for smooth-running cams at high speeds. The term **cycloidal**



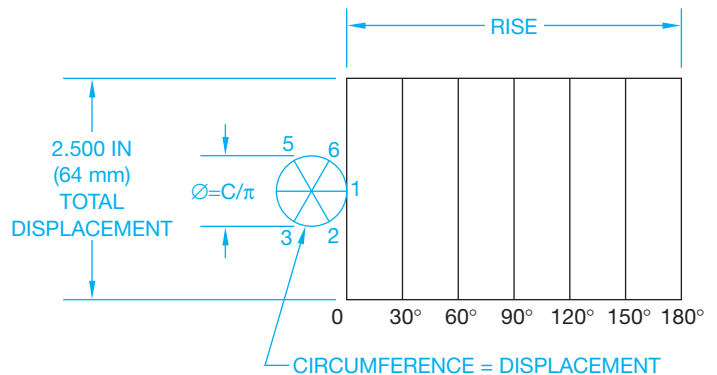
**FIGURE 16.29** Steps 1 and 2: Layout for uniform accelerated motion cam displacement diagram. © Cengage Learning 2012



**FIGURE 16.30** Step 3: Layout for uniform accelerated motion cam displacement diagram. © Cengage Learning 2012

comes from the word **cycloid**. A cycloid is a curved line generated by a point on the circumference of a circle as the circle rolls along a straight line. The cycloidal cam motion is developed in this same manner, and the result is the smoothest possible cam profile. Cycloidal motion is a little more complex to set up than other types of motion. Use the following procedure to develop a cam displacement diagram for cycloidal motion with a total rise of 2.500 in. (64 mm) in 180°.

- STEP 1** Begin the displacement diagram with a total rise of 2.500 in. (64 mm) in 180°. Only half of the diagram is shown for this example, because the other half is the same in reverse (see Figure 16.31).
- STEP 2** Draw a circle tangent to and centered on the total displacement at one end of the diagram. This circle must have a circumference equal to the displacement. Calculate the diameter using the formula  $D = C/\pi$ . In this case,  $D = 2.500/3.1414 = .7958$  (64/3.1414 = 20.37 mm). Then, beginning at the point where the circle is tangent to the diagram, divide the circle into six equal parts and number them as shown in Figure 16.31.
- STEP 3** Draw a vertical line through the center of the circle equal in length to the displacement. Divide this line into six equal parts as shown in Figure 16.32.



**FIGURE 16.31** Steps 1 and 2: Layout for cycloidal motion cam displacement diagram. © Cengage Learning 2012

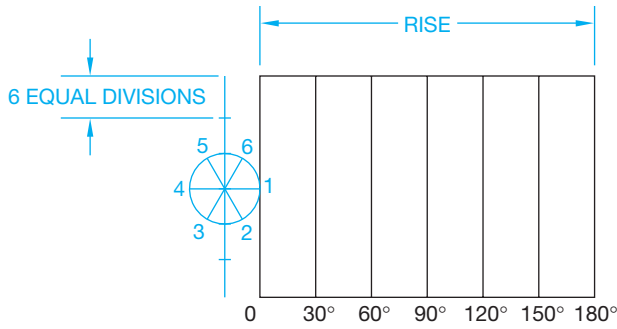


FIGURE 16.32 Step 3: Layout for cycloidal motion cam displacement diagram.

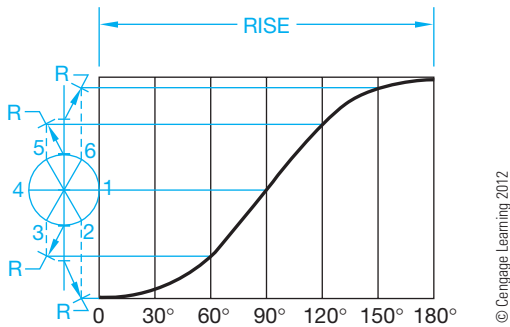


FIGURE 16.33 Step 4: Layout for cycloidal motion cam displacement diagram.

**STEP 4** Use a radius equal to the radius of the circle to draw arcs from the divisions on the vertical line as shown in Figure 16.33. These arcs should intersect the dashed lines drawn from points 2, 3, 5, and 6 on the circle. Where the dashed lines and the arcs intersect, draw horizontal lines into the displacement diagram, intersecting the appropriate increment from the horizontal scale. Connect the points of intersection with a smooth curve as shown in Figure 16.33.

### Developing a Cam Displacement Diagram with Different Cam Motions

Most cam profiles are not as simple as the preceding examples. Many designs require more than one type of cam motion and can incorporate dwell. Construct a cam displacement diagram from the following information:

- Total displacement equals 2.00 in. (50 mm).
- Rise 1.00 in. (25 mm) simple harmonic motion in 120°.
- Dwell for 30°.
- Rise 1.00 in. (25 mm) modified constant velocity motion in 90°.
- Fall 2.00 in. (50 mm) uniform accelerated motion in 90°.
- Dwell for 30° through the balance of the cycle.

Look at Figure 16.34 as you review the method of development for each type of cam motion displayed. The cam displacement diagram in Figure 16.34 uses simple harmonic motion, dwell, modified constant velocity motion, uniform accelerated motion, and a final dwell.

### CONSTRUCTION OF AN INLINE FOLLOWER PLATE CAM PROFILE

Each of the cam displacement diagrams can be used to construct the related cam profiles. The **cam profile** is the actual contour of the cam. In operation, the cam follower is stationary, and the cam rotates on the cam shaft. In cam profile construction, the cam is drawn in one position and the cam follower is moved to a series of positions around the cam in relationship to the cam displacement diagram. The following technique is used to draw the cam profile for the cam displacement diagram given in Figure 16.35 and for a cam with a 2.50 in. (64 mm) base circle, a .75 in. (17 mm) cam follower, and counterclockwise rotation.

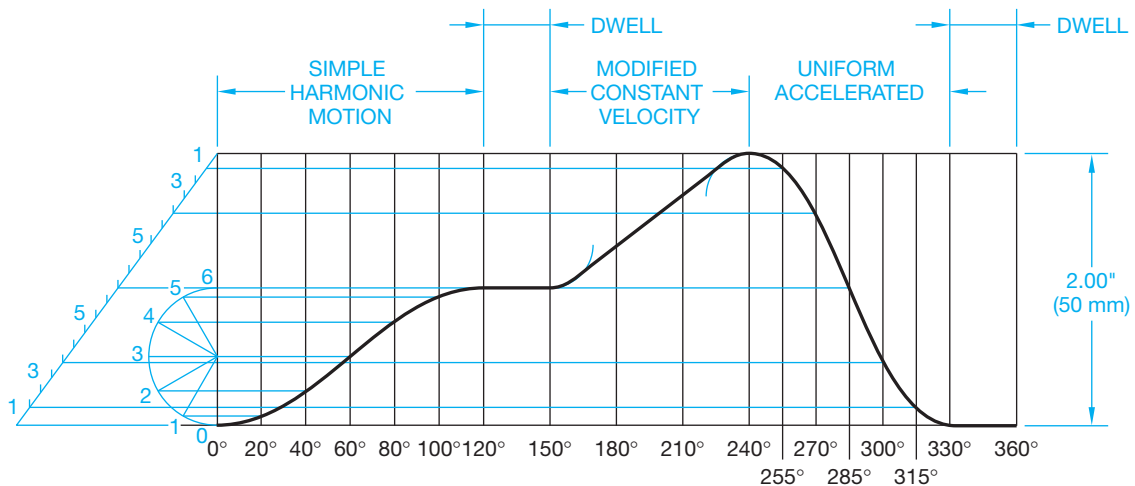
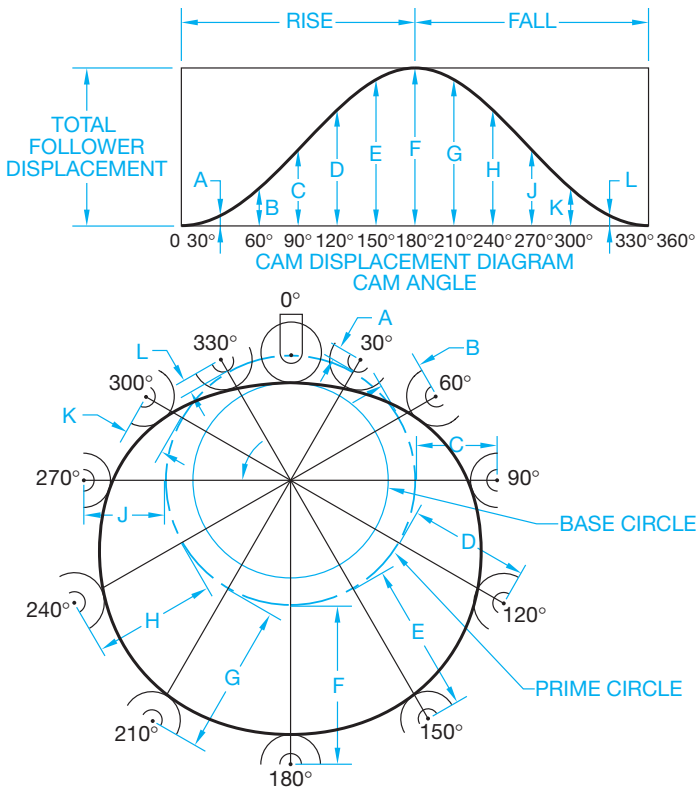


FIGURE 16.34 The development of a cam displacement diagram with different cam motions.



**FIGURE 16.35** Steps 1, 2, 3, 4, and 5: Construction of an inline follower plate cam profile. © Cengage Learning 2012

**STEP 1** Refer to Figure 16.35. Use construction lines for all preliminary work. Draw the cam follower in place near the top of the sheet with phantom lines. Draw the base circle of  $\text{Ø}2.50$  in. (64 mm). The base circle is tangent to the cam follower at the  $0^\circ$  position. Draw the prime circle  $2.50 + .75 = \text{Ø}3.25$  in. ( $64 + 17 = \text{Ø}83$  mm). The prime circle passes through the center of the cam follower at the  $0^\circ$  position. The cam displacement diagram is placed on Figure 16.35 for easy reference. In actual practice, the displacement diagram is next to the cam profile drawing or on a CADD layer to be inserted on the screen for reference.

**STEP 2** Begin working in a direction opposite from the rotation of the cam. Because this cam rotates counterclockwise, work clockwise. Starting at  $0^\circ$ , draw an angle equal to each of the horizontal scale angles on the displacement diagram. In this case, the angles are  $30^\circ$  increments. This is not true with all cam displacement diagrams. Some cam displacement diagrams have varying increments.

**STEP 3** Notice the measurements labeled A through L on the displacement diagram in Figure 16.35. Begin by transferring the distance A along the  $30^\circ$  element in the profile construction drawing by measuring from the prime circle along this line. This establishes the

center of the cam follower at this position. Do the same with each of the measurements B through L located on each corresponding increment.

**STEP 4** Use construction lines to draw the cam followers in position with centers located at each of the points found in Step 3 (see Figure 16.35).

**STEP 5** Draw the cam profile by connecting a smooth curve tangent to the cam followers at each position

## PREPARING THE FORMAL PLATE CAM DRAWING

You are ready to prepare the **formal plate cam drawing** after you have constructed the plate cam profile using the previously described techniques. The previous drawing can be used because all lines are drawn as construction lines on a CADD layer that can be turned off when the formal drawing is complete. The information needed on the plate cam drawing includes:

- Cam profile.
- Hub dimensions, including cam shaft, outside diameter, width, and keyway dimensions.
- Roller follower placed in one convenient location, such as  $60^\circ$ , using phantom lines.
- The drawing is set up as a chart drawing where  $A^\circ$  equals the angle of the follower at each position, and R equals the radius from the center of the cam shaft to the center of the follower at each position.
- A chart giving the values of the angles A and the radii R at each follower position.
- Side view showing the cam plate thickness and set screw location with thread specification, if used.
- Tolerances, unless otherwise specified.

Establish all measurements for dimensions A and R at each of the follower positions. This is done graphically by measuring from the profile construction or mathematically using trigonometry. The dimensions are taken directly from the layout using CADD measurement tools or commands. Figure 16.36 shows a formal plate cam drawing.

## CONSTRUCTION OF AN OFFSET FOLLOWER PLATE CAM PROFILE

When an **offset cam follower** is used, the method of construction is a little more complex than the technique used for the inline follower. For this example, the follower is offset .75 in. (17 mm) as shown in Figure 16.37. Prepare the cam profile drawing as follows:

**STEP 1** Refer to Figure 16.37. Use a construction CADD layer for all preliminary work. Draw the cam follower in place near the top of the sheet with phantom lines.

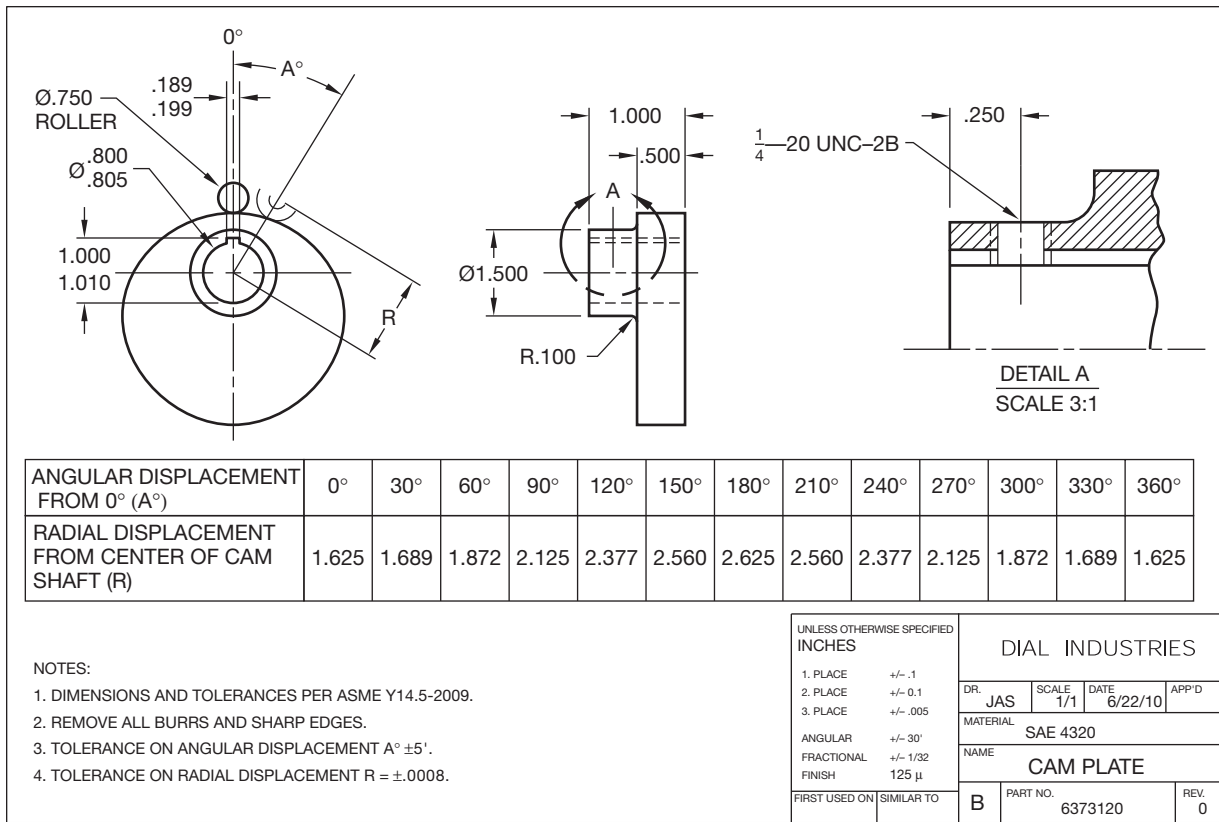
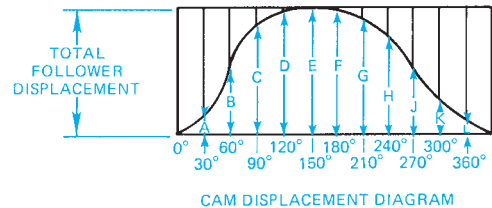


FIGURE 16.36 Formal plate cam drawing. Dimension values in this figure are in inches.

Draw the base circle  $\text{Ø}2.50$  in. (64 mm). The base circle is tangent to the follower at  $0^\circ$  position. Draw the prime circle:  $(2.50 + .75 = \text{Ø}3.25$  in.)  $(64 + 17 = \text{Ø}83$  mm). The prime circle passes through the center of the follower at  $0^\circ$  position. Draw the offset circle  $\text{Ø}1.50$  in. (38 mm). The offset circle is drawn with a radius equal to the follower offset distance. The cam displacement diagram is placed on Figure 16.37 for easy reference. In actual practice, the displacement diagram is next to the cam profile drawing or on a CADD layer to be inserted on the screen for reference.



**STEP 2** Begin working in a direction opposite from the rotation of the cam. Because this cam rotates counterclockwise, work clockwise. Starting at  $0^\circ$  on the offset circle, draw an angle equal to each of the horizontal scale angles on the displacement diagram. In this case, the angles are  $30^\circ$  increments. This is not true with all cam displacement diagrams, because some have varying increments.

**STEP 3** Notice where each of the angle increments drawn in Step 2 intersects the offset circle. At each of these points, draw another line tangent to the offset circle. Make these lines long enough to pass beyond the reference circle.

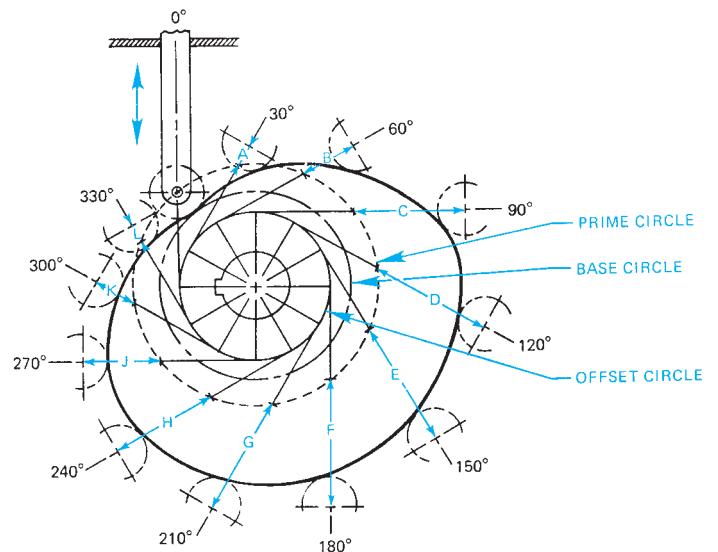


FIGURE 16.37 Steps 1, 2, 3, 4, 5, and 6: Construction of an offset follower plate cam profile. © Cengage Learning 2012

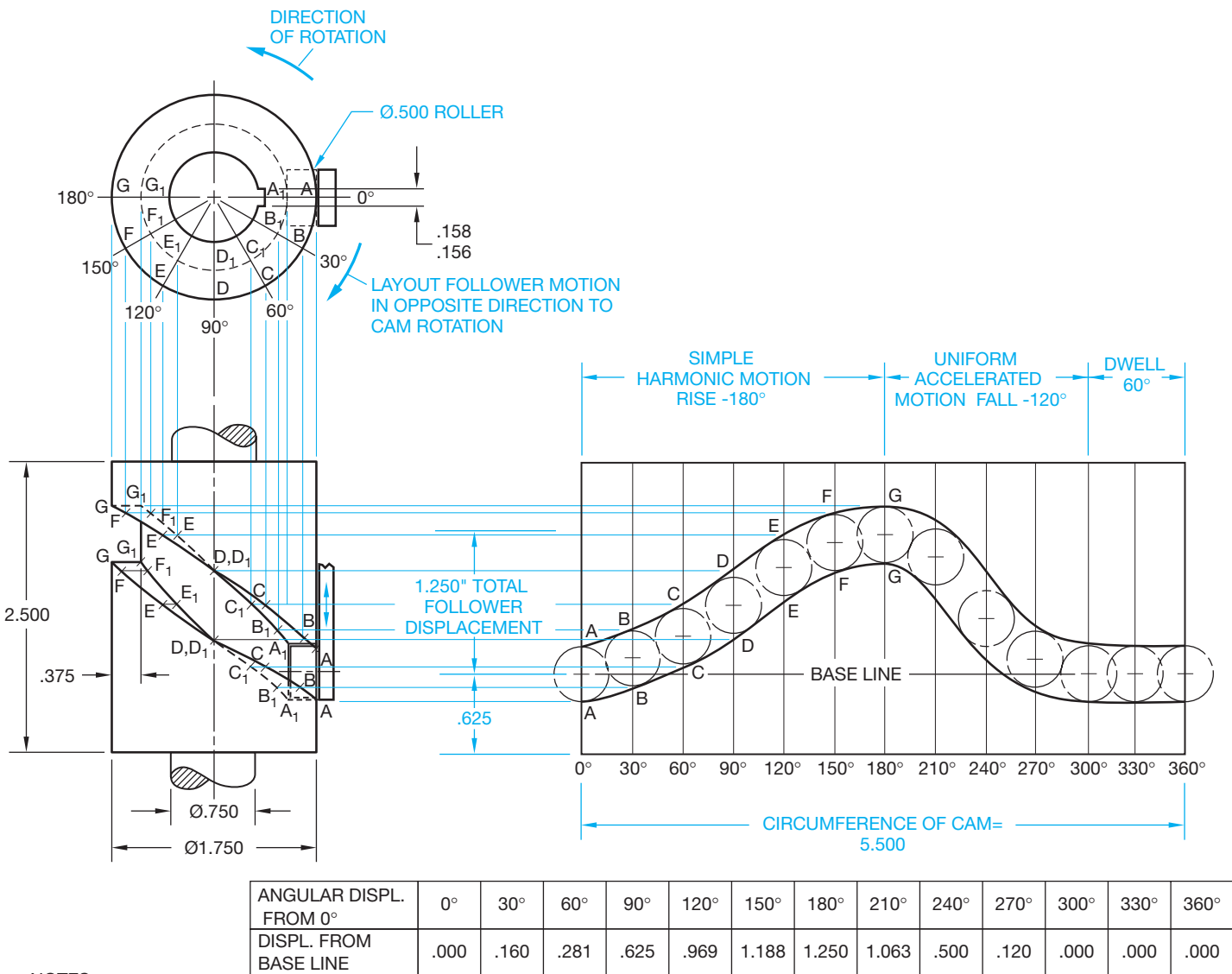


### DRUM CAM DRAWING

**Drum cams** are used when it is necessary for the follower to move in a path parallel to the axis of the cam. The drum cam is a cylinder with a groove machined in the surface in the shape of the cam profile. The cam follower moves along the path of the groove as the drum is rotated. The displacement diagram for a drum cam is the pattern of the drum surface as if it were rolled out flat. The height of the displacement diagram is equal to the height of the drum. The length of the displacement diagram is equal to the circumference of the drum. Refer to the drum cam drawing in Figure 16.38 as you follow the construction steps.

- STEP 4** Notice the measurements labeled A through L on the displacement diagram in Figure 16.37. Begin by transferring the distance A along the line tangent to the 30° element by measuring from the prime circle along this line. This establishes the center of the cam follower at this position. Do the same with each of the measurements B through L located on the tangent line from each corresponding increment.
- STEP 5** Using construction lines draw the cam followers in position with centers located at each of the points found in Step 4 (refer to Figure 16.37).
- STEP 6** Draw the cam profile by connecting a smooth curve tangent to the cam followers at each position.

- STEP 1** Draw the top view, showing the diameter of the drum, the cam shaft and keyway, and the roller follower in



- NOTES:
1. TOLERANCE ON DISPLACEMENT FROM BASELINE ± .0008.
  2. TOLERANCE ON ANGULAR DISPLACEMENT ± .5°.

**FIGURE 16.38** Steps 1, 2, 3, 4, and 5: Construction of a drum cam drawing. Dimension values in this figure are in inches. © Cengage Learning 2012

## CAM DESIGN

Designing cams is easy with a parametric CADD program. In a system of this type, all you have to do is change the variables and automatically create a new cam or gear. Cam design variables include:

- Type of cam motion.
- Follower displacement.
- The specific rise, dwell, and fall configuration.
- Prime circle and base circle diameters.
- Inline or offset follower.
- Hub diameter and projection, face width, shaft, and keyway specifications.

Specialized CADD software automatically calculates the rest of the data and draws the cam profile in a detail drawing.

## CAM DISPLACEMENT DIAGRAMS AND PROFILES

CADD systems make drawing cam displacement diagrams and cam profiles easy and accurate without the need for

mathematical calculations. Constructing the cam displacement diagram and converting the information to the cam profile is the same as with manual drafting, except the accuracy is increased substantially. Drawing the cam profile using irregular curves is difficult and time consuming. Most CADD systems have a curve-fitting command that makes it possible to draw the cam profile through the points of tangency at the cam follower positions automatically.

## CAM MANUFACTURING

Modern cams are manufactured using computer numerical control (CNC) machining. In many instances, the drawing is prepared on a CADD system and transferred to a CAM program for immediate coding for the CNC machine. Some CAM programs allow the designer to create the cam profile and transfer the data to the CNC machine tool without ever generating a drawing. Refer to Chapter 4, *Manufacturing Materials and Processes*, for more information.

place at  $0^\circ$ . Draw the front view as shown in Figure 16.38. Draw the outline of the cam displacement diagram equal to the height and circumference of the drum.

- STEP 2** Draw the roller follower on the displacement diagram at each angular interval.
- STEP 3** Draw curves tangent to the top and bottom of each roller follower position. These curves represent the development of the groove in the surface of the cam.
- STEP 4** In the top view, draw radial lines from the cam shaft center equal to the angle increments shown on the displacement diagram. Be sure to lay out the angles in a direction opposite the cam rotation. The points where these lines intersect the depth and the outside circumference of the groove are labeled A, A<sub>1</sub>, B, B<sub>1</sub>, respectively. Notice that the same corresponding points are labeled on the displacement diagram.
- STEP 5** From points A, A<sub>1</sub> on the displacement diagram, project horizontally until each point intersects a vertical line from the same corresponding point in the top view. This establishes the points in the front view along the outer and inner edges of the groove, both top and bottom. Continue this process for each pair of points on the drum cam displacement diagram.



### 3-D Animation

To see and operate the 3-D animation of a cam, go to the Student CD, select **Supplemental Material**, select **Chapter 16**, and select **3-D Animation of Cam Operation**. *Animation courtesy of Parametric Technology Corporation.*

## INTRODUCTION TO GEARS

**Gears** are toothed wheels used to transmit motion and power from one shaft to another. Gears are rugged and durable and can transmit power with up to 98% efficiency with long service life. Gear design involves a combination of material, strength, and wear characteristics. Most gears are made of cast iron or steel, but brass and bronze alloys and plastic are also used for some applications. Gear selection and design are often done through vendors' catalogs or the use of standard formulas. A **gear train** exists when two or more gears are used in combination to transmit power. Generally, two gears in mesh are used to increase or reduce speed or to change the direction of motion from one shaft to another. When two gears are in mesh, the larger is called the **gear** and the smaller is called the **pinion** (see Figure 16.39).

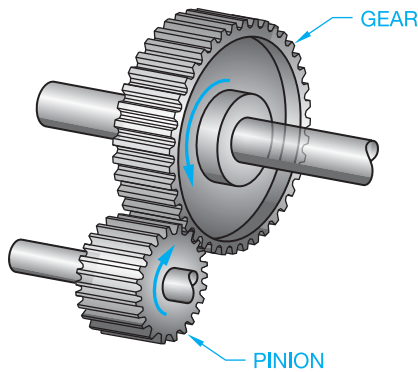


FIGURE 16.39 The gear and pinion.

© Cengage Learning 2012

## STANDARDS

**AGMA/ASME** Gear selection generally follows the guidelines of the American Gear Manufacturers Association (AGMA) publication AGMA 2000-A88, *Gear Classification and Inspection Handbook—Tolerances and Measuring Methods for Unassembled Spur and Helical Gears, including Metric Equivalents*, and the American Society of Mechanical Engineers (ASME) documents ASME Y14.7.1, *Gear Drawing Standards—Part 1: For Spur, Helical, Double Helical and Rack*. This standard covers drawing practices and data for parallel axes operating gears. ASME Y14.7.2 *Gear and Spline Drawing Standards—Part 2: Bevel and Hypoid Gears*. This standard covers drawing practices and data for gears with intersecting axes and nonparallel and nonintersecting axes.

It is important that you completely understand gear terminology and formulas. However, many drafters do not draw gears, because gears are commonly supplied as purchase parts. When this happens, you may be required to make gear selections for specific applications or draw gears on assembly drawings. Details of gears are often drawn using simplified techniques as described in this chapter. In many situations, gears are drawn as they actually exist for display on assembly drawings or in catalogs. Detailed gear drawings are commonly used over the simplified representation by most companies. The reason is that the CADD system makes drawing detailed gears easy, and their appearance on drawings is often preferred. Gear data is readily available in gear manufacturer catalogues or in the *Machinery's Handbook*.

## GEAR STRUCTURE

Gears are made in a variety of structures, depending on the design requirements, but there is some basic terminology that can typically be associated with gear structure. The elements of the gear structure shown in Figure 16.40 include the outside diameter, face, hub, bore, and keyway.

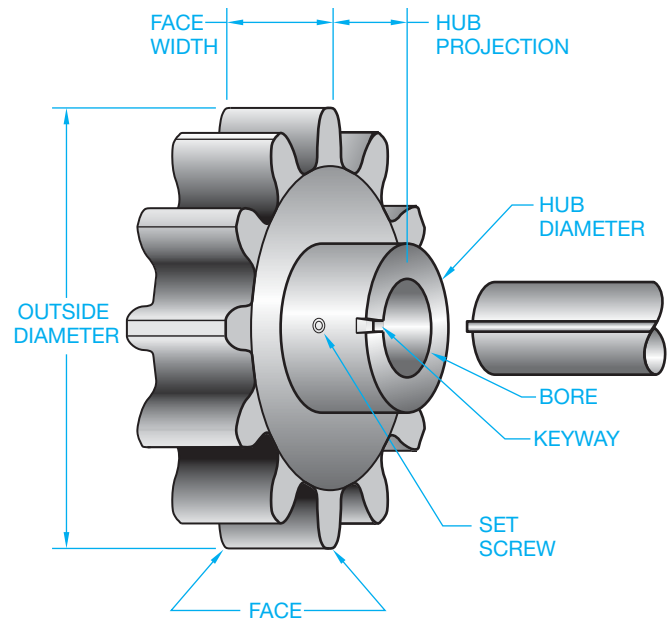


FIGURE 16.40 Elements of the gear structure.

© Cengage Learning 2012

## Types of Hubs

A gear **hub** is the lug or shoulder projecting from one or both faces of some gears. Gear hubs are referred to as A, B, or C hubs. An A hub is also called a *flush hub*, because there is no projection from the gear face. B hubs have a projection on one side of the gear, and C hubs have projections on both sides of the gear face (see Figure 16.41).

## Keyways, Keys, and Set Screws

Gears are usually held on the shaft with a key, keyway, and set screw. Refer to Chapter 4 for information on the manufacture of keyways, Chapter 10 for proper dimensioning, and Chapter 11 for screw thread specifications. One or more set screws are usually used to keep the key secure in the keyway (see Figure 16.42).

## SPLINES

**Splines** are teeth cut in a shaft and a gear or pulley bore, and they are used to prevent the gear or pulley from spinning on the shaft. Splines are often used when it is necessary for the gear or **pulley** to easily slide on the shaft. Splines can also be nonsliding and in all cases are stronger than keyways and keys. The standardization of splines is established by the Society of Automotive Engineers (SAE), so any two parts with the same spline specifications fit together. A pulley is a wheel with a flat, convex, or grooved rim mounted on a shaft and driven by a belt or other means. Pulleys are described in Chapter 17, *Belt and Chain Drives*.

The following is an example of an SAE spline specification:

SAE 2 1/2-10 B SPLINE  
(A) (B) (C) (D)

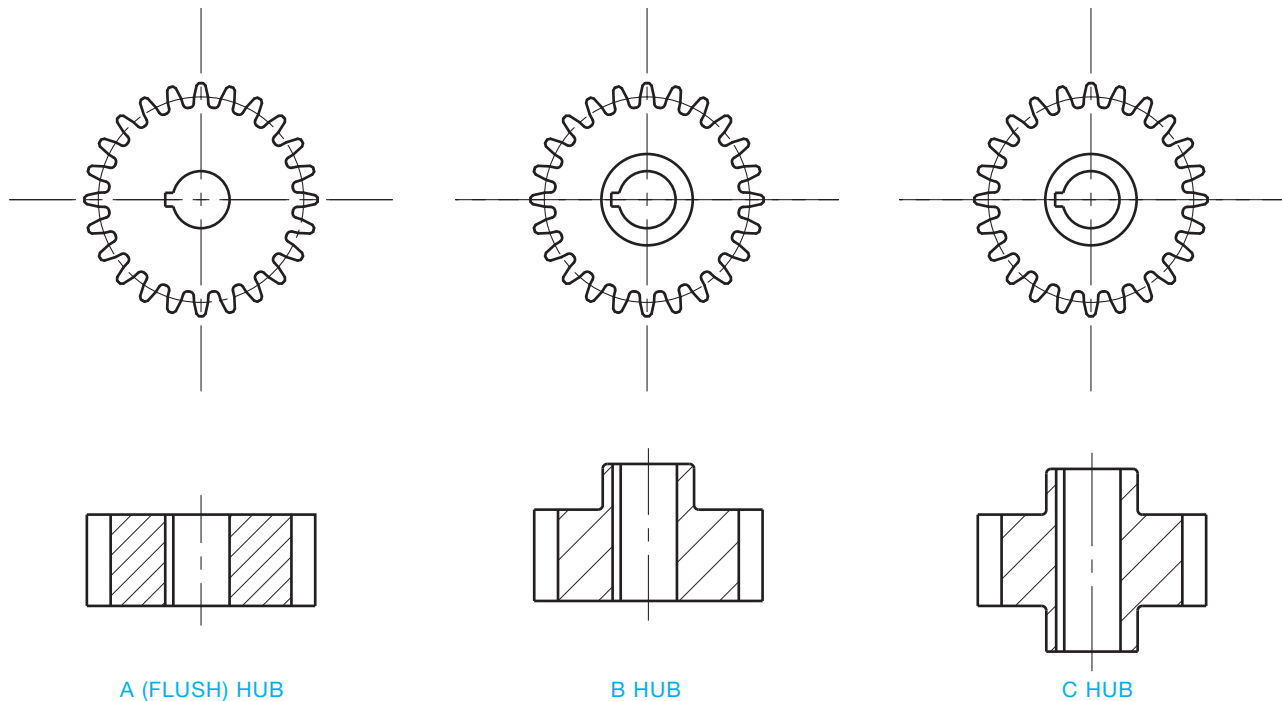


FIGURE 16.41 Types of gear hubs.

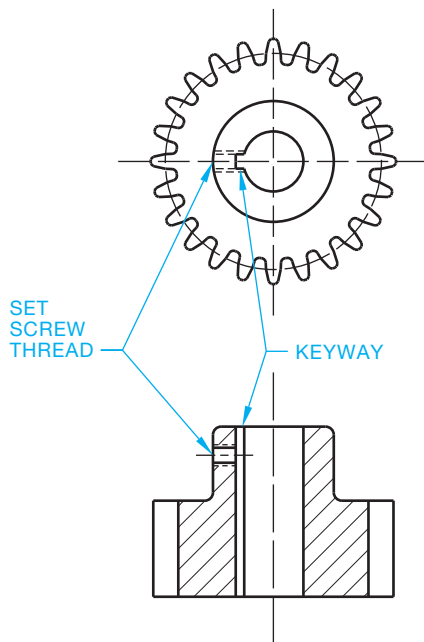


FIGURE 16.42 Gear, keyways, and set screw.

## STANDARDS

**ANSI/SAE** Several standards govern drafting and specifications for splines. These include the American National Standards Institute (ANSI) document ANSI B92.1, *Involute Splines and Inspection—Inch Version*, and the Society of Automotive Engineers (SAE) document *Standard Straight Sided Splines*.

The note components are described as follows:

- (A) Society of Automotive Engineers.
- (B) The outside diameter of the spline.
- (C) The number of teeth.
- (D) A = a fixed nonsliding spline.  
     B = spline slides under no-load conditions.  
     C = spline slides under load conditions.

## Involute Spline

Another spline standard is the **involute spline**. The teeth on the involute spline are similar to the curved teeth found on spur gears. The spline teeth generally have a shorter whole depth than standard spur gears, and the pressure angle is normally  $30^\circ$ .

## GEAR TYPES

The most common and simplest form of gear is the spur gear. Bevel gears and worm gears are also used. Gear types are designed based on one or more of the following elements:

- The relationship of the shafts: parallel, intersecting, nonintersecting shafts, or rack and pinion.
- Manufacturing cost.
- Ease of maintenance in service.
- Smooth and quiet operation.
- Load-carrying ability.
- Speed reduction capabilities.
- Space requirements.

## Parallel Shafting Gears

Many different types of mating gears are designed with parallel shafts. These include spur and helical gears.

### Spur Gears

**Spur gears** are designed to transmit motion and power between parallel shafts. There are two basic types of spur gears: **external** and **internal spur gears** (see Figure 16.43). When two or more spur gears are cut on a single shaft, they are referred to as **cluster gears**. External spur gears are designed with the teeth of the gear on the outside of a cylinder. External spur gears are the most common type of gear used in manufacturing. Internal spur gears have the teeth on the inside of the cylindrical gear. The advantages of spur gears over other types are their low manufacturing cost, simple design, and ease of maintenance. The disadvantages include less load capacity and higher noise levels than other types.

### Helical Gears

**Helical gears** have their teeth cut at an angle, allowing more than one tooth to be in contact (see Figure 16.44). Helical gears carry more load than equivalent-sized spur gears and operate more quietly and smoothly. The disadvantage of helical gears is that they develop **end thrust**. End thrust is a lateral force exerted on the end of the gear shaft. Thrust bearings are required to reduce the effect of this end thrust. Double helical gears are designed to eliminate the end thrust and provide long life under heavy loads. However, they are more difficult and costly to manufacture. The **herringbone gear** shown in Figure 16.45 is a double helical gear without space between the two opposing sets of teeth.

## Intersecting Shafting Gears

**Intersecting shafting gears** allow for the change in direction of motion from the gear to the pinion. Different types of intersecting shafting gears include bevel and face gears.

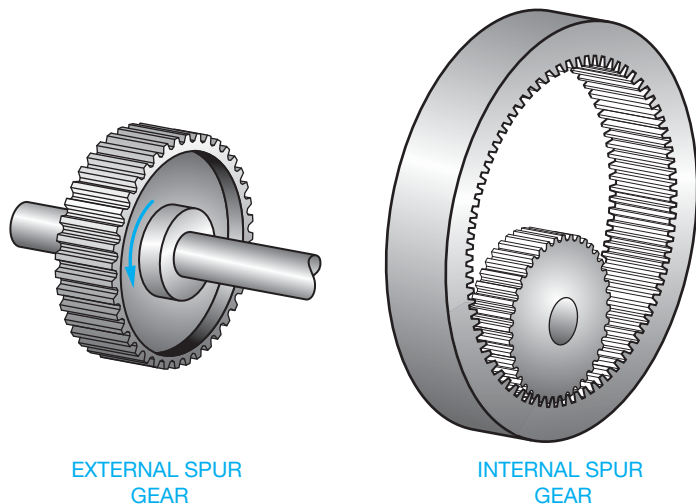


FIGURE 16.43 Spur gears. © Cengage Learning 2012

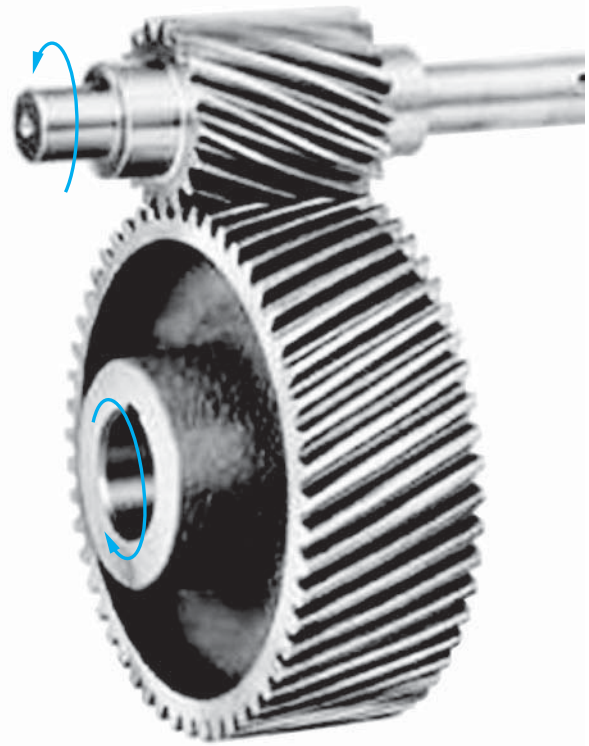


FIGURE 16.44 Helical gear.

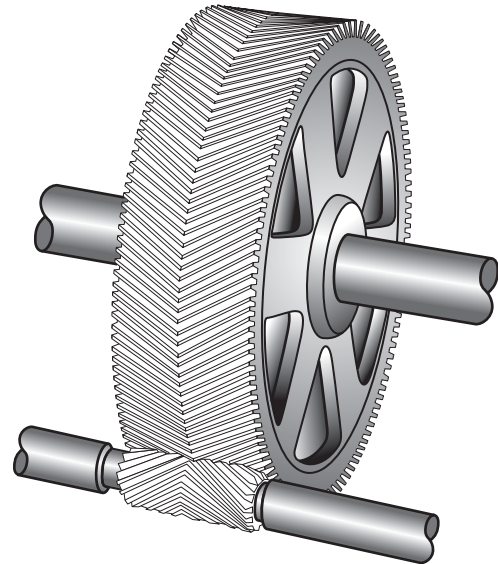
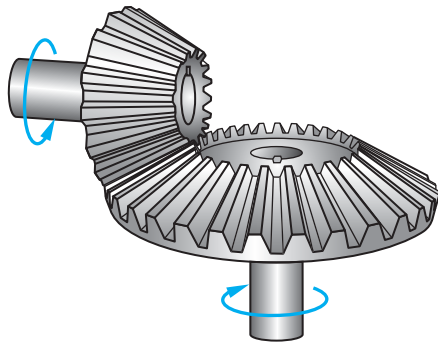


FIGURE 16.45 Herringbone gear.

### Bevel Gears

**Bevel gears** are conical in shape, allowing the shafts of the gear and pinion to intersect at  $90^\circ$  or any desired angle. The teeth on the bevel gear have the same shape as the teeth on spur gears except they taper toward the apex of the cone. Bevel gears provide for a speed change between the gear and pinion (see Figure 16.46). **Miter gears** are the same as bevel gears, except



© Cengage Learning 2012

FIGURE 16.46 Bevel gears.

both the gear and pinion are the same size and are used when shafts must intersect at  $90^\circ$  without speed reduction. Spiral bevel gears have the teeth cut at an angle, which provides the same advantages as helical gears over spur gears.

### Face Gears

The **face gear** is a combination of bevel gear and spur pinion, or bevel gear and helical pinion. This combination is used when the mounting accuracy is not as critical as with bevel gears. The load-carrying capabilities of face gears are not as good as those of bevel gears.

### Nonintersecting Shafting Gears

Gears with shafts that are at right angles but not intersecting are referred to as **nonintersecting shafts**. Gears that fall into this category are crossed helical, hypoid, and worm gears.

### Crossed Helical Gears

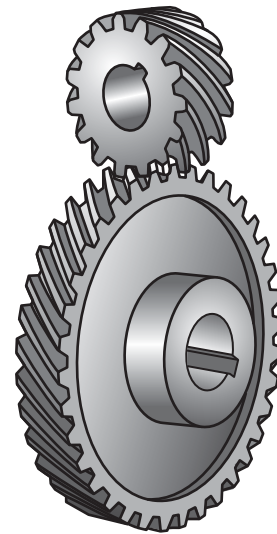
Also known as **right angle helical gears** or **spiral gears**, **crossed helical gears** provide for nonintersecting right angle shafts with low load-carrying capabilities (see Figure 16.47).

### Hypoid Gears

**Hypoid gears** have the same design as bevel gears except the gear shaft axes are offset and do not intersect (see Figure 16.48). The gear and pinion are often designed with bearings mounted on both sides for improved rigidity over standard bevel gears. Hypoid gears are very smooth, strong, and quiet in operation.

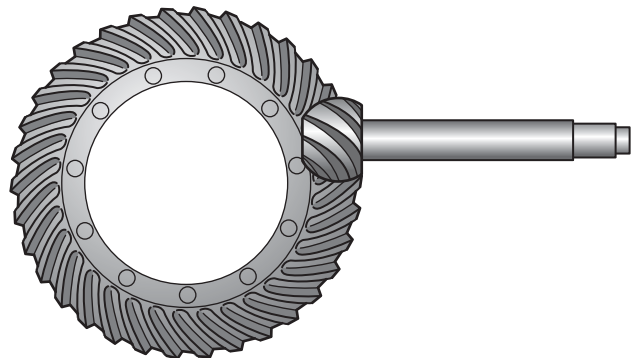
### Worm Gears

A **worm and worm gear** are shown in Figure 16.49. This type of gear is commonly used when a large speed reduction is required in a small space. The worm can be driven in either direction. When the gear is not in operation, the worm automatically locks in place. This is an advantage when it is important for the gears to have no movement of free travel when the equipment is shut off.



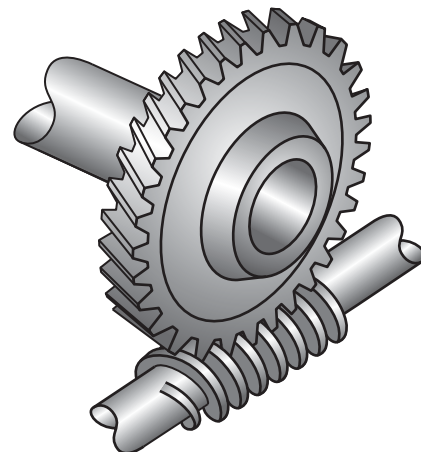
Courtesy of Emerson Industrial Automation

FIGURE 16.47 Crossed helical gears.



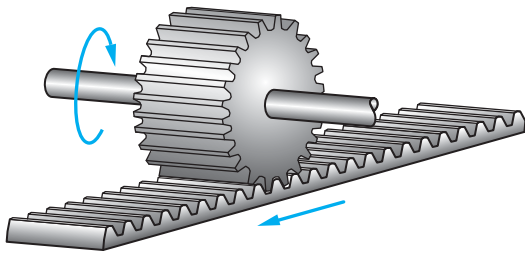
© Cengage Learning 2012

FIGURE 16.48 Hypoid gears.



© Cengage Learning 2012

FIGURE 16.49 Worm and worm gear.



© Cengage Learning 2012

FIGURE 16.50 Rack and pinion.

## Rack and Pinion

A **rack** and **pinion** is a spur pinion operating on a flat straight bar rack (see Figure 16.50). The rack and pinion is used to convert rotary motion into straight line motion.

## SPUR GEAR DESIGN

Spur gear teeth are straight and parallel to the gear shaft axis. The tooth profile is designed to transmit power at a constant rate and with a minimum of vibration and noise. To achieve these requirements, an **involute curve** is used to establish the gear tooth profile. An involute curve is a spiral curve generated by a point on a chord as it unwinds from the circle. The contour of a gear tooth, based on the involute curve, is determined by a base circle, the diameter of which is controlled by a pressure angle. The **pressure angle** is the direction of push transmitted from a tooth on one gear to a tooth on the mating gear or pinion (see Figure 16.51). Two standard pressure angles,  $14.5^\circ$  and  $20^\circ$ , are used in spur gear design. The most commonly used pressure angle is  $20^\circ$  because it provides a stronger tooth for quieter running and heavier load-carrying characteristics. One of the basic rules of spur gear design is to

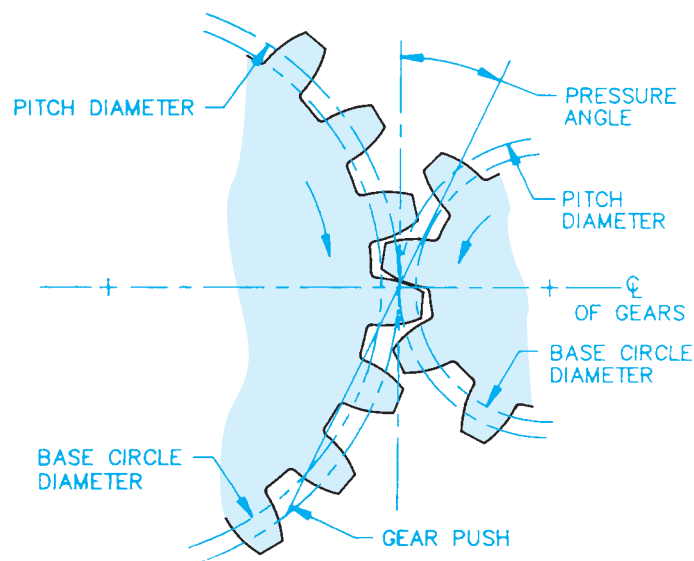


FIGURE 16.51 The spur gear pressure angle and related terminology.  
© Cengage Learning 2012

have no fewer than 13 teeth on the running gear and 26 teeth on the mating gear.

Standard terminology and formulas control the drawing requirements for spur gear design and specifications. Figure 16.52 shows a pictorial representation of the spur gear teeth with the components labeled. As an engineering drafter, it is important for you to become familiar with the terminology and associated mathematical formulas used to calculate values.

## Diametral Pitch

The **diametral pitch** refers to the tooth size and has become the standard for tooth size specifications. As you look at Figure 16.53, notice how the tooth size increases as the diametral pitch decreases. One of the most elementary rules of gear tooth design is that mating teeth must have the same diametral pitch.

### STANDARDS

**GEAR ACCURACY AGMA** A system has been established by the American Gear Manufacturers Association (AGMA) for the classification of gears based on the accuracy of the maximum tooth-to-tooth tolerances allowed. The **AGMA quality numbers** and corresponding maximum tolerances are established by diametral pitch and pitch diameter. The AGMA quality numbers are listed in *AGMA Gear Handbook, 2000-A88*. The higher the AGMA quality number, the tighter the tolerance. For example, an AGMA Q6 allows approximately .004 total composite error, Q10 is less than .001, and Q13 is less than .0004. The *AGMA Gear Handbook* also displays a list of gear applications and the quality number suggested for each application.

## DRAWING SPECIFICATIONS AND TOLERANCES

The final step in designing a gear is the presentation of a drawing displaying the dimensioned gear using multiviews and gear data charts. Companies do not always provide the complete gear data charts on their drawings, and errors can happen when complete data is not provided. Gear data formulas and sample gear data charts are shown with examples in this chapter. The AGMA recommended information for spur and helical gears is also in Appendix AA.

## DESIGNING AND DRAWING SPUR GEARS

### STANDARDS

**ANSI/AGMA** The drafting standard governing gear drawings is the American National Standards Institute document ANSI Y14.7.1, *Gear Drawing Standards—Part I*. AGMA gear specifications and quality numbers are listed in *AGMA Gear Handbook, 2000-A88*.

Term	Description	Formula
Pitch Diameter (D)	The diameter of an imaginary pitch circle on which a gear tooth is designed. Pitch circles of two spur gears are tangent.	$D = N/P$
Diametral Pitch (P)	A ratio equal to the number of teeth on a gear per inch of pitch diameter.	$P = N/D$
Number of Teeth (N)	The number of teeth on a gear.	$N = D \cdot P$
Circular Pitch (p)	The distance from a point on one tooth to the corresponding point on the adjacent tooth, measured on the pitch circle. Circular pitch is the same as linear pitch on a rack. See Figure 16.66.	$p = 3.1416 \cdot D/N$ $p = 3.1416/P$
Center Distance (C)	The distance between the axis of two mating gears.	$C = \text{sum of pitch DIA}/2$
Addendum (a)	The radial distance from the pitch circle to the top of the tooth.	$a = 1/P$
Dedendum (b)	The radial distance from the pitch to the bottom of the tooth. (This formula is for 20° teeth only.)	$b = 1.250/P$
Whole Depth (h <sub>t</sub> )	The full height of the tooth. It is equal to the sum of the addendum and the dedendum.	$h_t = a + b$ $h_t = 2.250/P$
Working Depth (h <sub>k</sub> )	The distance that a tooth occupies in the mating space. A distance equal to two times the addendum.	$h_k = 2a$ $h_k = 2.000/P$
Clearance (c)	The radial distance between the top of a tooth and the bottom of the mating tooth space. It is also the difference between the addendum and dedendum.	$c = b - a$ $c = .250/P$
Outside Diameter (D <sub>o</sub> )	The overall diameter of the gear. It is equal to the pitch diameter plus two addendums.	$D_o = D + 2a$
Root Diameter (D <sub>r</sub> )	The diameter of a circle coinciding with the bottom of the tooth spaces.	$D_r = D - 2b$ $t = 1.5708/P$
Circular Thickness (t)	The length of an arc between the two sides of a gear tooth measured on the pitch circle.	
Chordal Thickness (t <sub>c</sub> )	The straight-line thickness of a gear tooth measured on the pitch circle. Chordal thickness is also referred to as tooth thickness.	$t_c = D \sin(90^\circ/N)$
Chordal Addendum (a <sub>c</sub> )	The height from the top of the tooth to the line of the chordal thickness.	$a_c = a + t^2/4D$
Pressure Angle (∅)	The angle of direction of pressure between contacting teeth. It determines the size of the base circle and the shape of the involute teeth.	
Base Circle Diameter (D <sub>B</sub> )	The diameter of a circle from which the involute tooth form is generated.	$D_B = D \cos \emptyset$

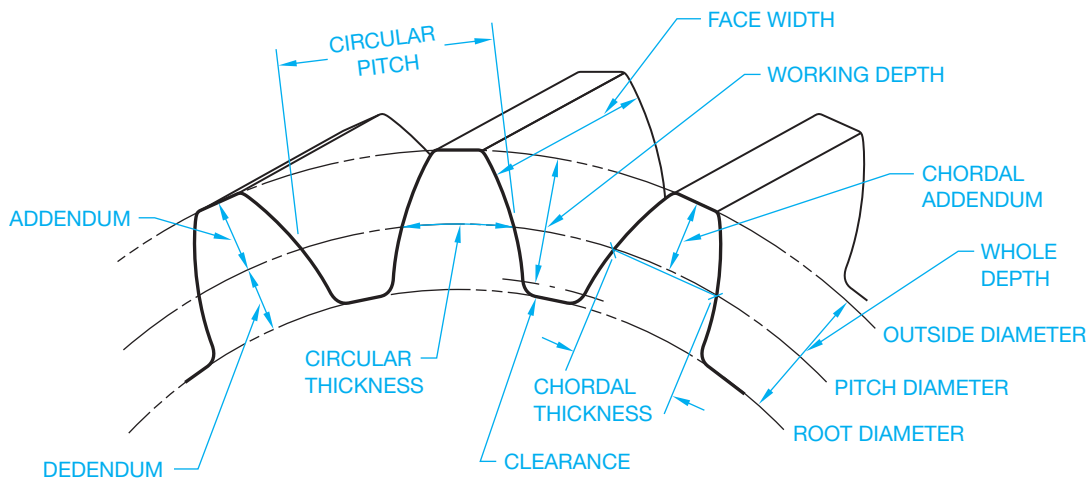
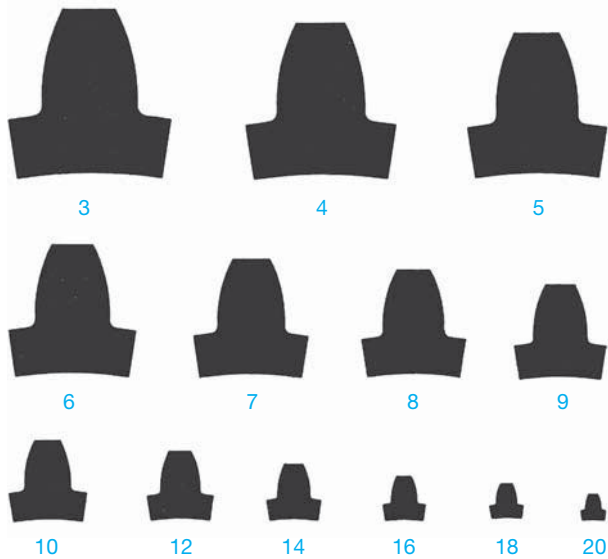


FIGURE 16.52 Spur gear teeth with the components labeled and correlated spur gear terminology with calculation formulas.





© Cengage Learning 2012

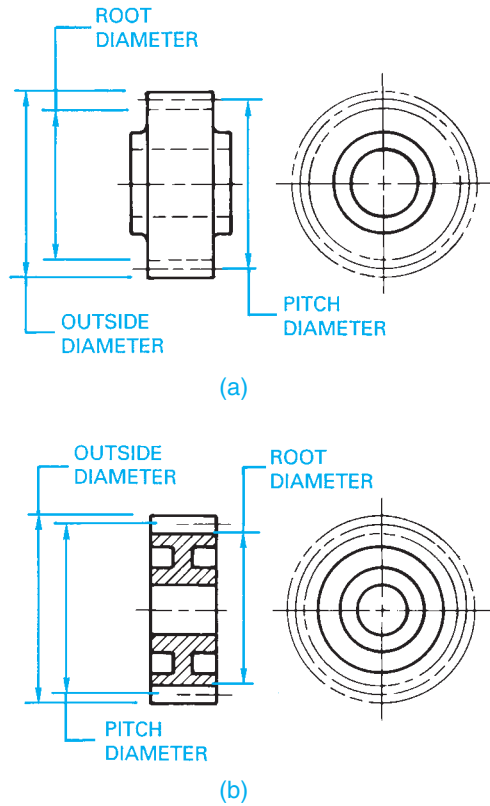
FIGURE 16.53 Diametral pitch.

There are two types of spur gear representations that can be used on drawing: simplified and detailed. Gear teeth are complex and can be time consuming to draw. For these reasons, simplified representations can be used to make the practice easier (see Figure 16.54). The simplified method shows the outside diameter and the root diameters as phantom lines and the pitch diameter as a centerline in the circular view. A side view is normally required to show width dimensions and related features (see Figure 16.54a). A full section is typically used if the gear construction has webs, spokes, or other items that require further clarification (see Figure 16.54b). Notice in the full section in Figure 16.54b that the gear tooth is left unsectioned and the pitch diameter is shown as a centerline. The simplified representation can be a practical option with CADD, because drawing the first detailed spur gear tooth can be time consuming and is not necessary when accurate gear data is provided. Confirm this practice with your school or company.

This applies unless an automated gear program is used that makes drawing detailed gear teeth easy. The detailed spur gear representation is used when necessary or desired to show the actual gear teeth on the drawing. Figure 16.55 shows a complete spur gear drawing using a detailed representation. Special gear generation software is available that allows you to automatically create detailed gear teeth by inputting the related gear data. Without this specialty gear software, it is necessary to construct a gear tooth and then use a command or tool such as CIRCULAR PATTERN or ARRAY to duplicate the tooth around the circumference of the gear. The following describes how to create a detailed gear tooth when automated 3-D modeling or gear design software is not available.

### Drawing a Detailed Gear Representation

A detailed gear representation closely duplicates the profile of a gear, but it is a representation so it does not have to be perfect. You need to create an involute curve in order to draw the true



© Cengage Learning 2012

FIGURE 16.54 Typical spur gear drawings using simplified gear teeth representation. (a) Simplified spur gear representation in multiview. (b) Simplified spur gear representation in section.

geometry of a gear tooth. As previously defined, an involute curve is a spiral curve generated by a point on a chord as it unwinds from the circle. Drawing an actual involute curve for a spur gear requires several mathematical formulas and complex construction. Creating an approximate representation of a spur gear tooth is more practical. The following steps demonstrate how to draw an approximate spur gear tooth and use the tooth profile to create the detailed spur gear drawing. The following given information is used to draw the detailed spur gear representation:

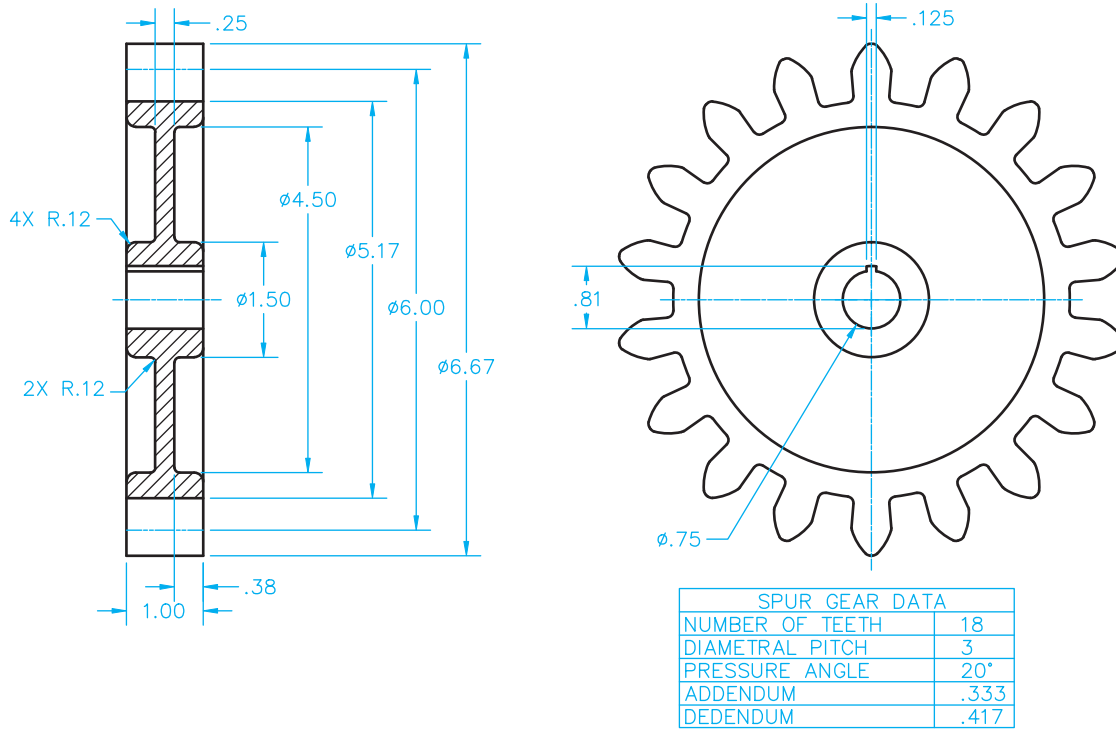
- Number of teeth (N) = 18.
- Diametral pitch (P) =  $N/D = 3$ .
- Pressure angle =  $20^\circ$ .

The following specifications are calculated using the formulas in this chapter:

- Pitch diameter (D) =  $N/P = 6.000$
- Dedendum (b) =  $1.25/P = .417$ .
- Addendum (a) =  $1/P = .333$ .
- Root diameter ( $D_r$ ) =  $D - 2b = 5.375$
- Outside diameter ( $D_o$ ) =  $D + 2a = 6.500$

**STEP 1** Calculate the pitch diameter using the following formula:

$$\text{Pitch diameter (D)} = N/P = 6.000$$



© Cengage Learning 2012

FIGURE 16.55 Typical spur gear drawings using detailed gear teeth representation.

**STEP 2** Calculate the root diameter using the following formula:

$$\text{Root diameter (Dr)} = D - 2b = 5.375$$

**STEP 3** Calculate the outside diameter using the following formula:

$$\text{Outside diameter (Do)} = D + 2a = 6.500$$

**STEP 4** Draw the root diameter, pitch diameter, and outside diameter using the previous calculations as shown in Figure 16.56a.

**STEP 5** Draw the circular thickness on the circumference of the pitch diameter by converting the circular thickness to an angular value using the following formula:

$$360/N \times .5 = 360/18 \times .5 = 10^\circ$$

Use the 10° value to draw a 10° angle on one side of the vertical centerline with the angle vertex at the center of the gear as shown in Figure 16.56a. This example draws the 10° angle on the left side of the vertical centerline. Figure 16.56b shows a detail view of the angular value used for establishing the circular thickness. Notice the pitch point where the vertical side of the 10° angle intersects the pitch diameter. It is important for the pitch point to be located at the intersection of the pitch diameter and the vertical gear centerline.

**STEP 6** Draw the 20° pressure angle with one side horizontal and tangent to the pitch diameter and the vertex located at the pitch point as shown in Figure 16.57. Now

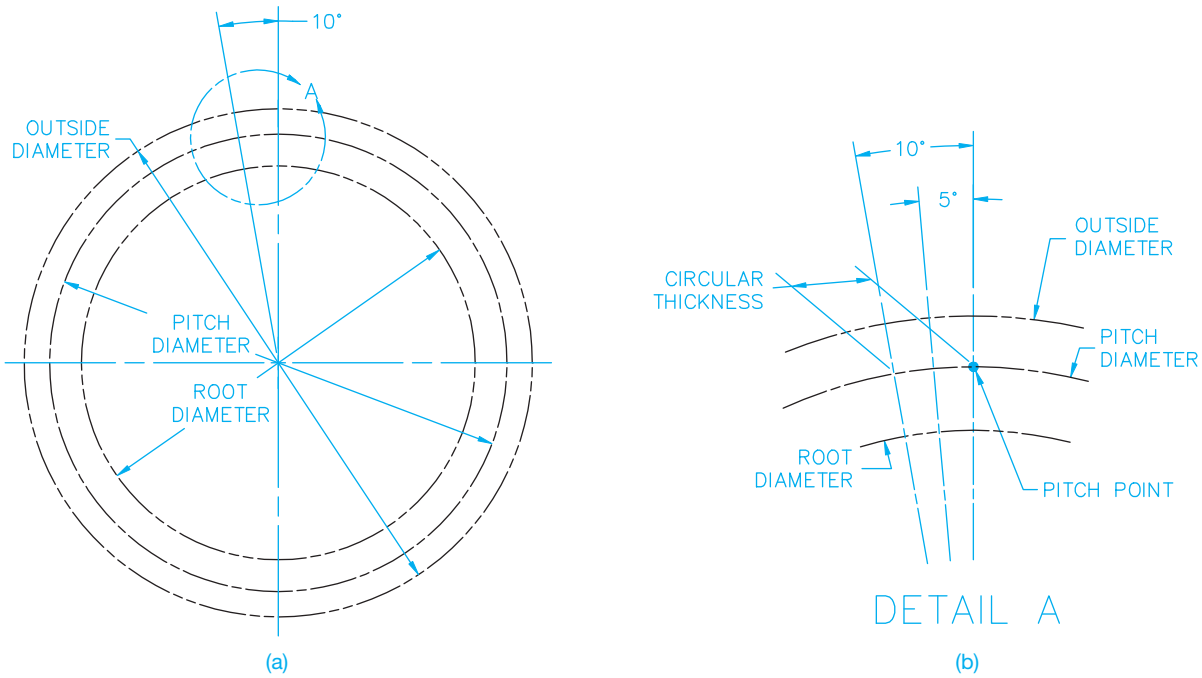
the base circle diameter is drawn tangent to the side of the 20° pressure angle as shown in Figure 16.57.

**STEP 7** Calculate the radius of a circle equal to  $.125D = .125 \times 6.000 = .750$ . Draw a circle using this radius with the center (A) at the pitch point as shown in Figure 16.58. Use this circle as the construction to locate point B on the base circle as shown in Figure 16.58. Draw the circle again using the same .750 radius with the center at point B where the circumference of the first circle intersects the base circle. The second circle establishes the upper tooth profile shown in Figure 16.59.

**STEP 8** To establish the lower tooth profile, draw a construction line from the pitch point to the center of the pitch diameter as shown in Figure 16.59. The center of the pitch diameter is the center of the gear.

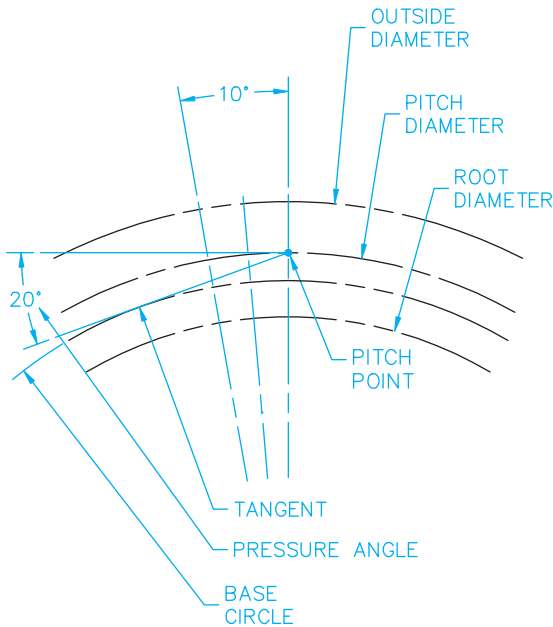
**STEP 9** Continue the gear tooth construction by drawing a small round on the tooth at the pitch diameter and a small fillet on the tooth at the root diameter. Use a command or tool such as MIRROR to duplicate the left side of the tooth profile as shown in Figure 16.60. Draw a horizontal line segment to flatten the top of the tooth as shown in Figure 16.60.

**STEP 10** Use a command or tool such as ARRAY or CIRCULAR PATTERN to duplicate the tooth around the circumference of the gear. Fill in missing line segments and trim unwanted line segments as needed. Turn off or freeze the construction layer. The finished gear profile is shown in Figure 16.61.



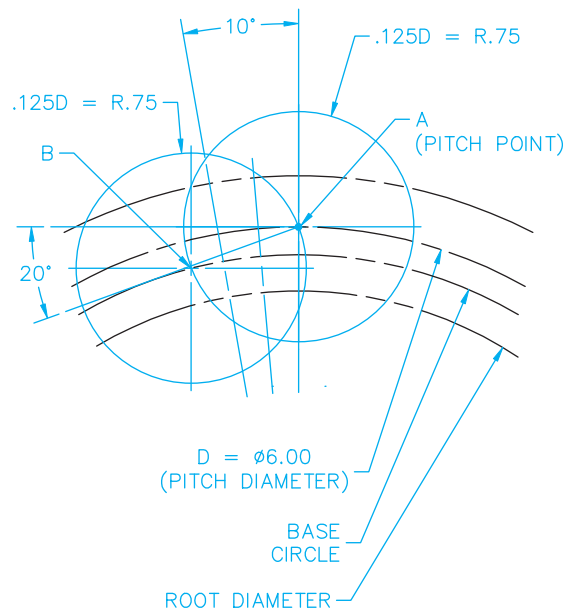
**FIGURE 16.56** (a) Step 4: Draw the root diameter, pitch diameter, and outside diameter using the calculations from Steps 1, 2, and 3. (b) Step 5: Establish the circular thickness on the circumference of the pitch diameter.

© Cengage Learning 2012



© Cengage Learning 2012

**FIGURE 16.57** Step 6: Draw the 20° pressure angle with one side horizontal and tangent to the pitch diameter and with the vertex at the pitch point.



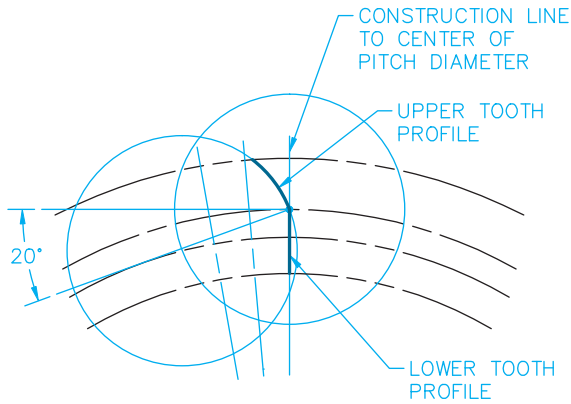
© Cengage Learning 2012

**FIGURE 16.58** Step 7: Draw a circle using the calculated radius with the center at (A). Use this circle as the construction to locate point B on the root diameter. Draw the circle again using the same radius with the center at point B. The second circle establishes the upper tooth profile.

**STEP 11** Complete the spur gear drawing by adding design features such as a hub, bore, web, keyway, and spur gear data. Figure 16.62 shows the final spur gear drawing with a front view, a full sectional view, and spur gear data.

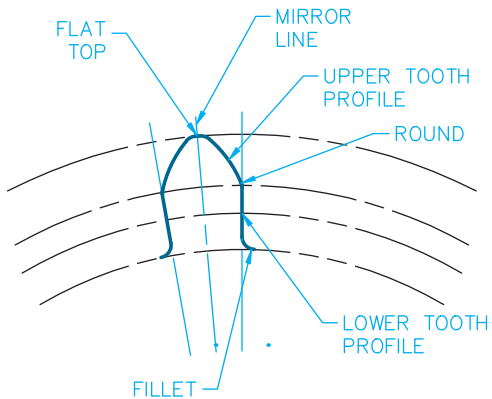
### Drawing a Gear Tooth Related to Another Feature

One or more teeth can be drawn for specific applications. For example, when a tooth must be in alignment with another



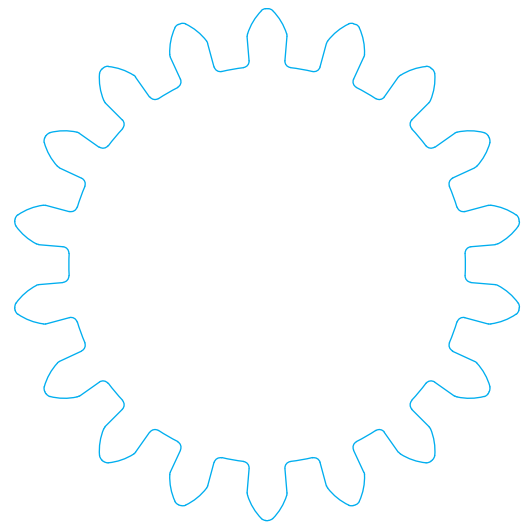
© Cengage Learning 2012

**FIGURE 16.59** Step 8: To establish the lower tooth profile, draw a construction line from the right pitch point to the center of the pitch diameter.



© Cengage Learning 2012

**FIGURE 16.60** Step 9: The left side of the tooth profile. Draw a horizontal line segment to flatten the top of the tooth.



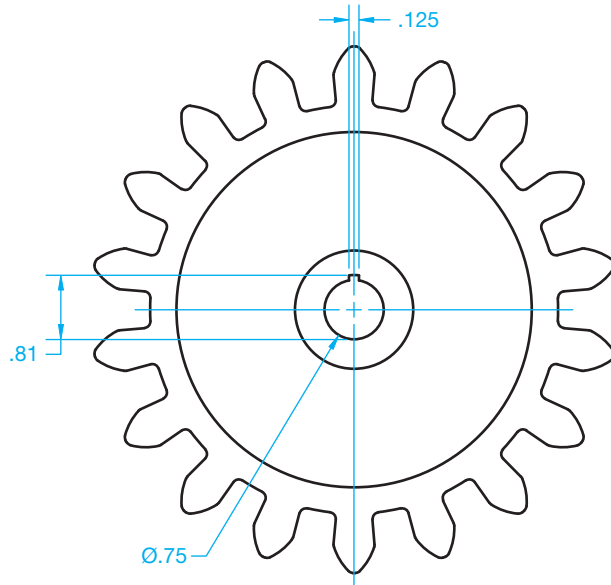
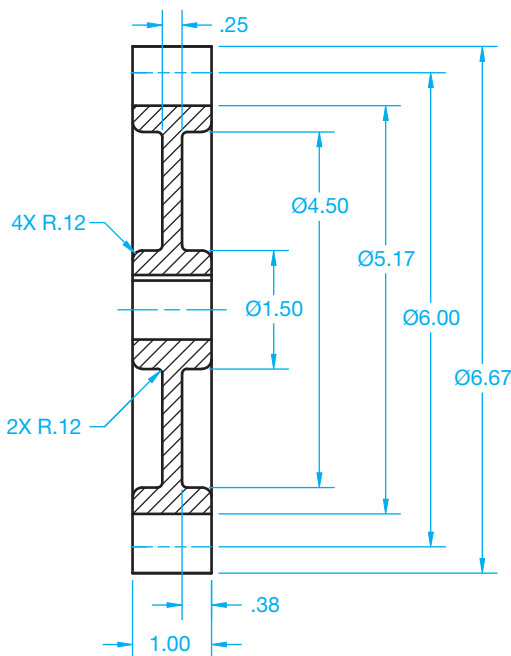
© Cengage Learning 2012

**FIGURE 16.61** Step 10: Use a command or tool such as a CIRCULAR PATTERN or ARRAY to duplicate the tooth around the circumference of the gear.

feature of the gear, the tooth and related feature can be drawn as shown in Figure 16.63.

### Drawing a Cluster Gear

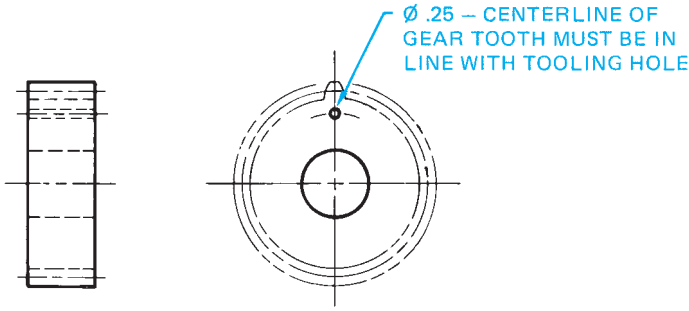
When cluster gears are drawn, the circular view can show both sets of gear tooth representations in one front view as shown in Figure 16.64a. For additional clarity, two circular views can be drawn to improve the representation as shown in



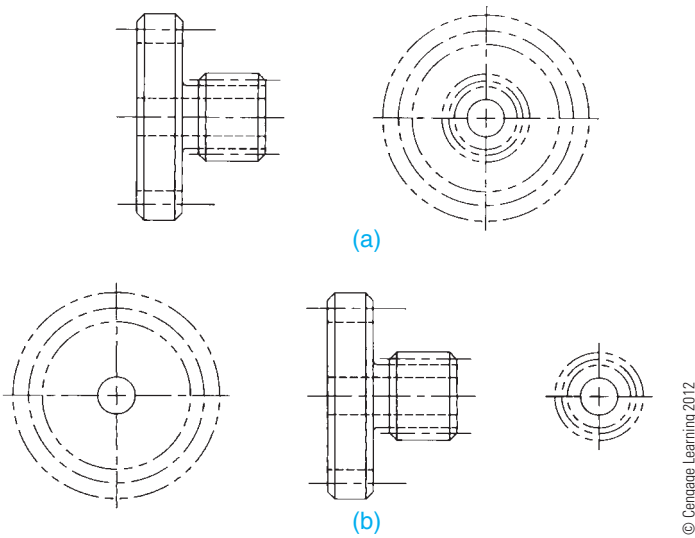
SPUR GEAR DATA	
NUMBER OF TEETH	18
DIAMETRAL PITCH	3
PRESSURE ANGLE	20°
ADDENDUM	.333
DEDENDUM	.417

© Cengage Learning 2012

**FIGURE 16.62** Step 11: Complete the spur gear drawing by adding a hub, bore, web, keyway, and spur gear data.



**FIGURE 16.63** Showing the relationship of one gear tooth to another feature on the gear. Dimension values in this figure are in inches. © Cengage Learning 2012



**FIGURE 16.64** Cluster gear drawings. (a) Cluster gear drawing using two views. (b) Cluster gear drawing using three views for added clarity.

Figure 16.64b. The detailed or simplified gear representation can be used. When cluster gears are more complex than shown here, multiple views and removed sections can be required.

### DESIGNING SPUR GEAR TRAINS

A gear train is an arrangement of two or more gears connecting driving and driven parts of a machine. Gear reducers and transmissions are examples of gear trains. The function of a gear train is to:

- Transmit motion between shafts.
- Decrease or increase the speed between shafts.
- Change the direction of motion.

It is important that you understand the relationship between two mating gears in order to design gear trains. When gears are designed, the result is often a specific **gear ratio**. Any two gears in mesh have a gear ratio. The gear ratio is expressed as a proportion, such as 2:1 or 4:1, between two similar values. The

gear ratio between two gears is the relationship between the following characteristics:

- Number of teeth.
- Pitch diameters.
- Revolutions per minute (rpm).

If you have gear A (pinion) mating with gear B, as shown in Figure 16.65, the gear ratio is calculated by dividing the number of teeth or the pitch diameter values of the smaller gear into the larger gear as follows:

$$\frac{\text{Number of Teeth}_{\text{Gear B}}}{\text{Number of Teeth}_{\text{Gear A}}} = \text{Gear Ratio}$$

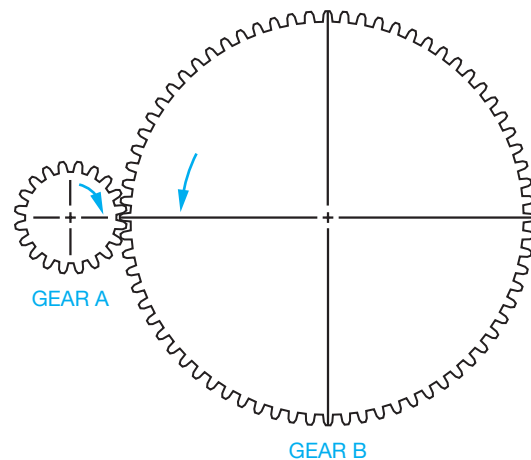
$$\frac{\text{Pitch Diameter}_{\text{Gear B}}}{\text{Pitch Diameter}_{\text{Gear A}}} = \text{Gear Ratio}$$

The gear ratio can also be calculated by dividing the rpm values of the larger gear into the smaller gear using this formula:

$$\frac{\text{rpm}_{\text{Gear A}}}{\text{rpm}_{\text{Gear B}}} = \text{Gear Ratio}$$

Now, calculate the gear ratio for the two mating gears in Figure 16.65 if gear A has 18 teeth, 6 in. pitch diameter, and operates at 1200 rpm; and gear B has 54 teeth, 18 in. pitch diameter, and operates at 400 rpm:

Characteristic	Calculation	Ratio
Number of teeth	= 54/18	= 3:1
Pitch diameter	= 18/6	= 3:1
Rpm	= 1200/400	= 3:1



	(D) PITCH DIAMETER	(N) NUMBER OF TEETH	(P) DIAMETRAL PITCH	RPM	DIRECTION
GEAR A	6	18	3	1200	C.WISE
GEAR B	18	54	3	400	C.C.WISE

**FIGURE 16.65** Calculating gear data. Dimension values in this figure are in inches. © Cengage Learning 2012

You can solve for unknown values in the gear train if you know the desired gear ratio, the number of teeth and pitch diameter of one gear, and the input speed. For example, gear A has 18 teeth, a pitch diameter of 6 IN, and an input speed of 1200 rpm; and the ratio between gear A and gear B is 3:1. To keep this information organized, it is best to set up a chart similar to the one shown in Figure 16.65. The unknown values are shown in color for your reference. Determine the number of teeth for gear B as follows:

$$\text{Teeth}_{\text{Gear A}} \times \text{Gear Ratio} = 18 \times 3 = \text{Teeth}_{\text{Gear B}} = 54$$

Alternatively, if you know that gear B has 54 teeth and the gear ratio is 3:1, then:

$$\frac{\text{Teeth}_{\text{Gear B}}}{\text{Gear Ratio}} = \frac{54}{3} = \text{Teeth}_{\text{Gear A}} = 18$$

Determine the rpm of gear B:

$$\frac{\text{rpm}_{\text{Gear A}}}{\text{Gear Ratio}} = \frac{1200}{3} = \text{rpm}_{\text{Gear B}} = 400$$

Determine the pitch diameter of gear B:

$$\text{Pitch Diameter}_{\text{Gear A}} \times \text{Gear Ratio} = 6 \text{ IN} \times 3 = \text{Pitch Diameter}_{\text{Gear B}} = 18 \text{ IN}$$

In some situations, it is necessary for you to refer to the formulas given in Figure 16.52 to determine unknown values. In this case, it is necessary to calculate the diametral pitch using the formula  $P = N/D$ , where  $P$  = diametral pitch,  $N$  = number of teeth, and  $D$  = pitch diameter:

$$P_{\text{Gear A}} = \frac{N}{D} = \frac{18}{6} = 3$$

The diametral pitch is the tooth size and the teeth for mating gears must be the same size. This means the diametral pitch is 3 for gear A and gear B.

Keep in mind that the preceding example presents only one set of design criteria. Other situations can be different. Always solve for unknown values based on information that you have and work with the standard formulas presented in this chapter. The following are important points to keep in mind as you work with the design of gear trains:

- The rpm of the larger gear is always slower than the rpm of the smaller gear.
- Mating gears always turn in opposite directions.
- Gears on the same shaft (cluster gears) always turn in the same direction and at the same speed (rpm).
- Mating gears have the same size teeth, which is the diametral pitch.
- The gear ratio between mating gears is a ratio between the number of teeth, the pitch diameters, and the rpm.
- The distance between the shafts of mating gears is equal to  $1/2 D_{\text{Gear A}} + 1/2 D_{\text{Gear B}}$ . This distance is  $3 + 9 = 12$  in. between shafts in Figure 16.65.

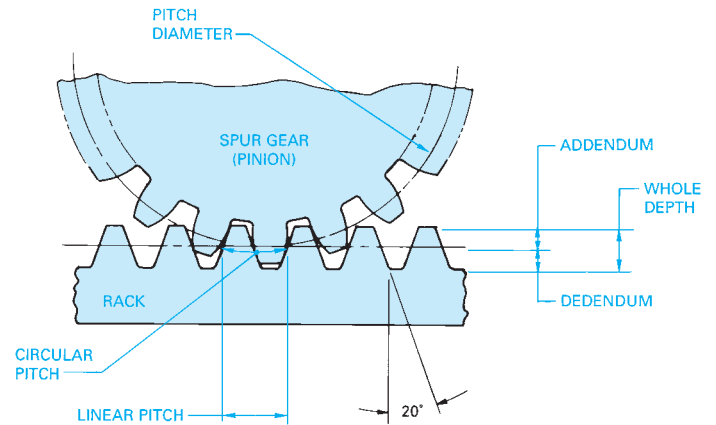


FIGURE 16.66 Rack and pinion terminology. © Cengage Learning 2012

## DESIGNING AND DRAWING THE RACK AND PINION

A rack is a straight bar with spur teeth used to convert rotary motion to reciprocating motion. Figure 16.66 shows a spur gear pinion mating with a rack. Notice the circular dimensions of the pinion become linear dimensions on the rack. This means that linear pitch = circular pitch.

When preparing a simplified detailed drawing of the rack, the front view is normally shown with the profile of the first and last tooth drawn. Phantom lines are drawn to represent the outside and root diameters, and a centerline is used for the pitch diameter and **pitch line**. The pitch line is the line on the rack that is tangent to the pitch diameter on the gear pinion (see Figure 16.67). Related tooth and length dimensions are also placed on the front view, and a depth dimension is placed on the side view. A spur gear data chart is placed in the field of the drawing or next to or over the title block to identify specific gear-cutting information. A rack detail drawing can also have all teeth displayed using the detailed representation.

## DESIGNING AND DRAWING BEVEL GEARS

Bevel gears are designed to transmit power between intersecting shafts at  $90^\circ$ , although they can be designed for any angle. Some gear design terminology and formulas relate specifically to the construction of bevel gears. These formulas and a drawing of a bevel gear and pinion are shown in Figure 16.68. Most of the gear terms discussed for spur gears apply to bevel gears. In many cases, information must be calculated using the formulas provided in the spur gear discussion shown in Figure 16.52.

The drawing for a bevel gear is similar to the drawing for a spur gear, but in many cases, only one view is needed. This view is often a full section. Another view can be used to show the dimensions for a keyway. As with other gear drawings, a chart is used to specify gear-cutting data (see Figure 16.69). Notice in this example that a side view is used to specify the bore and keyway.

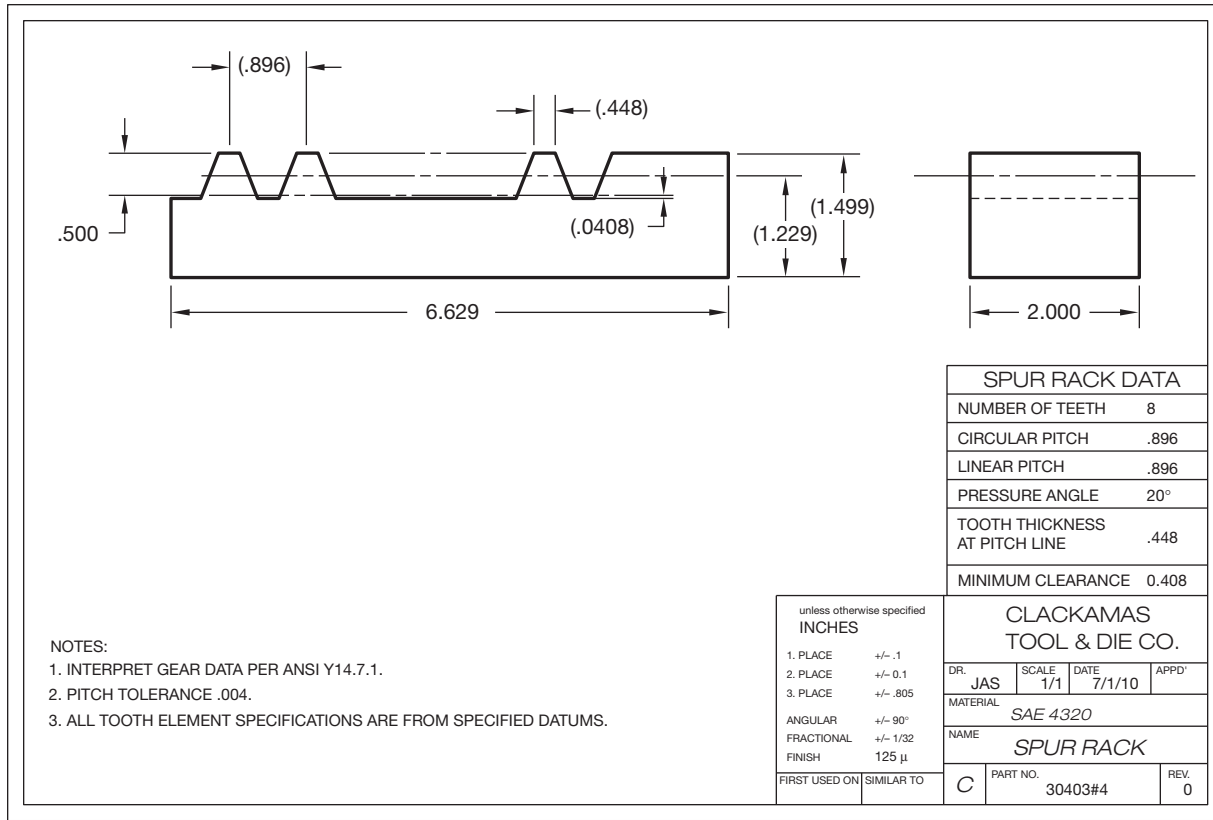
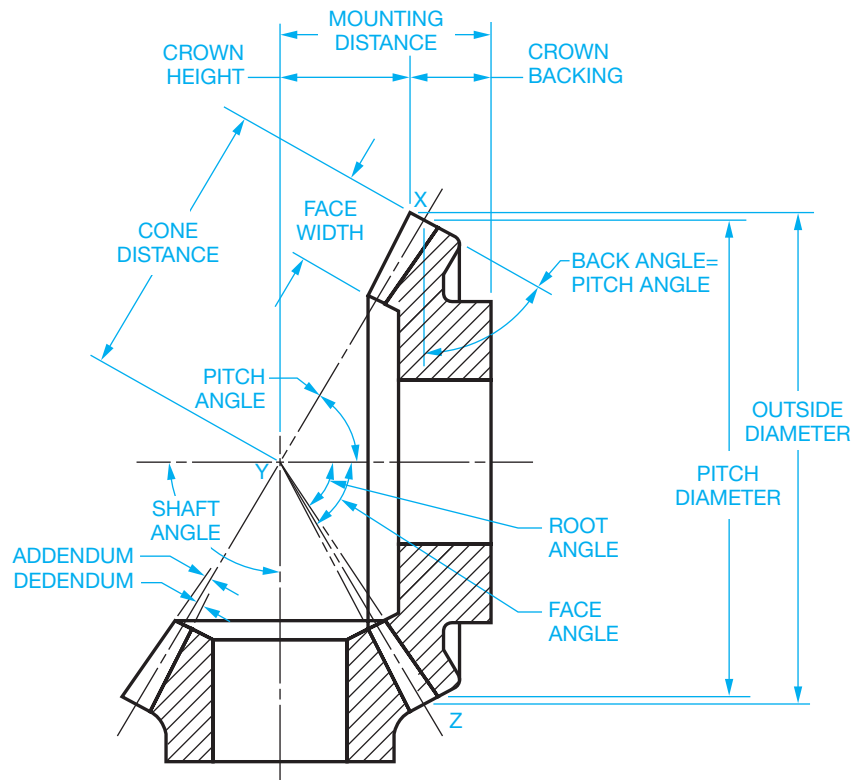


FIGURE 16.67 A detailed drawing of a rack. Dimension values in this figure are in inches.

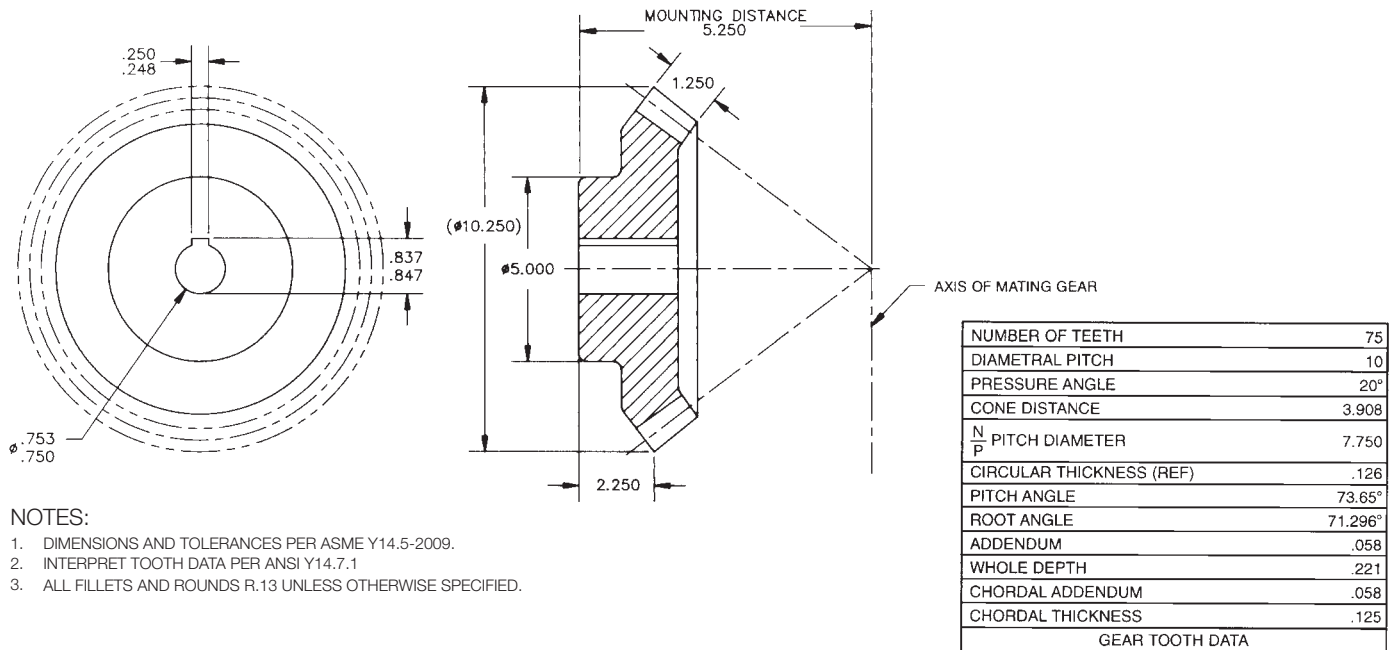
Term	Description	Formula
Pitch Diameter ( $D$ )	The diameter of the base of the pitch cone.	$D = N/P$
Pitch Cone	In Figure 16.68, the pitch cone is identified as XYZ.	$\tan \phi_a = D_a/D_b$
Pitch Angle ( $D$ )	The angle between an element of a pitch cone and its axis. Pitch angles of mating gears depend on their relative diameters (gear a and gear b).	$\tan \phi_b = D_a/D_b$
Cone Distance ( $A$ )	Slant height of pitch cone.	$A = D/2 \sin \phi$
Addendum Angle ( $d$ )	The angle subtended by the addendum. It is the same for mating gears.	$\tan \delta = a/A$
Dedendum Angle ( $V$ )	The angle subtended by the dedendum. It is the same for mating gears.	$\tan \Omega = b/A$
Face Angle ( $\phi_o$ )	The angle between the top of the teeth and the gear axis.	$\phi_o = \phi - \delta$
Root Angle ( $\phi_r$ )	The angle between the bottom of the tooth space and the gear axis.	$\phi_r = \phi - \Omega$
Outside Diameter ( $D_o$ )	The diameter of the outside circle of gear.	$D_o = D + 2a (\cos \phi)$
Crown Height ( $X$ )	The distance between the cone apex and the outer tip of the gear teeth.	$X = .5(D_o)/\tan \phi_o$
Crown Backing ( $Y$ )	The distance from the rear of the hub to the outer tip of the gear tooth, measured parallel to the axis of the gear.	
Face Width	A distance that should not exceed one-third of the cone distance ( $A$ ).	

FIGURE 16.68 Bevel gear terminology and formulas.



© Cengage Learning 2012

FIGURE 16.68 (Continued)



NOTES:

1. DIMENSIONS AND TOLERANCES PER ASME Y14.5-2009.
2. INTERPRET TOOTH DATA PER ANSI Y14.7.1
3. ALL FILLETS AND ROUNDS R.13 UNLESS OTHERWISE SPECIFIED.

© Cengage Learning 2012

FIGURE 16.69 A detailed drawing of a bevel gear. Dimension values in this figure are in inches.

## DESIGNING AND DRAWING WORM GEARS

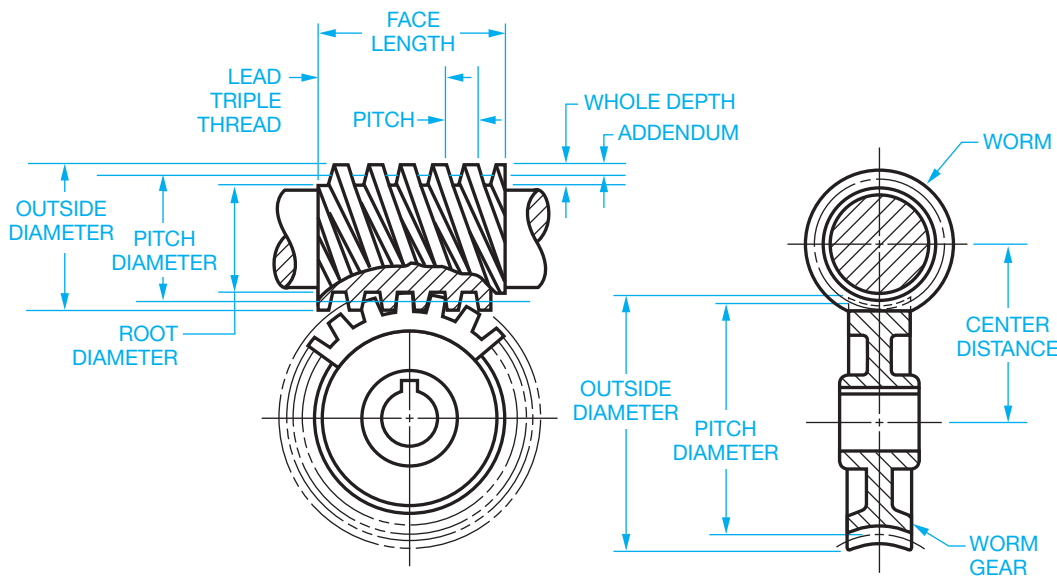
**Worm gears** are used to transmit power between nonintersecting shafts, and they are used for large speed reductions in a small space as compared to other types of gears. Worm

gears are strong, move in either direction, and lock in place when the machine is not in operation. A **single lead** worm advances one pitch with every revolution. A **double lead** worm advances two pitches with each revolution. As with bevel gears, the worm gear and worm have specific terminology and formulas that apply to their design. Figure 16.70 shows the



Term	Description	Formula
Pitch Diameter (worm) ( $D_w$ )		$D_w = 2C - D_g$
Pitch Diameter (gear) ( $D_g$ )		$D_g = 2C - D_w$
Pitch ( $P$ )	The distance from one tooth to the corresponding point on the next tooth measured parallel to the worm axis. It is equal to the circular pitch on the worm gear.	$P = L/T$
Lead ( $L$ )	The distance the thread advances axially in one revolution of the worm.	$L = D_g/R$ $L = P \times T$
Threads ( $T$ )	Number of threads or starts on worm.	$T = L/P$
Gear Teeth ( $N$ )	Number of teeth on worm gear.	$N = \pi D_g/P$
Ratio ( $R$ )	Divide number of gear teeth by the number of worm threads.	$R = N/T$
Addendum ( $a$ )	For single and double threads.	$a = .318P$
Whole Depth ( $WD$ )	For single and double threads.	$WD = .686P$

NOTE: REFER TO THE FORMULAS ON PAGE 697 FOR ADDITIONAL CALCULATIONS.



© Cengage Learning 2012

FIGURE 16.70 Worm and worm gear terminology and formulas.

representative worm gear and worm technology and design formulas.

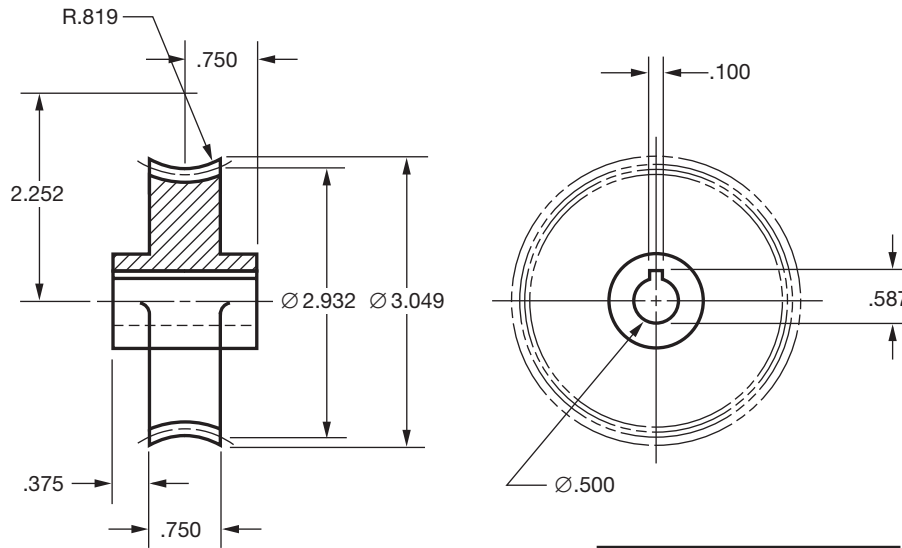
When drawing the worm gear, the same techniques are used as discussed earlier. Figure 16.71 shows a worm gear drawing using a half section method. A side view is provided to dimension the bore and keyway, and a chart is given for gear-cutting data.

A detail drawing of the worm is prepared using two views. The front view shows the first gear tooth on each end with phantom lines between for a simplified representation. The side view is the same as a spur gear drawing with the keyway specifications. The gear-cutting chart is placed on the field of the drawing or next to or over the title block. A detailed representation of the worm can also be drawn if preferred. Figure 16.72 shows the worm drawing using CADD to provide a detailed representation of the worm teeth in the front view rather than using phantom lines as in the simplified representation.

## PLASTIC GEARS

The following is taken in part from *Plastic Gearing* by William McKinlay and Samuel D. Pierson, published by ABA/PGT Inc., Manchester, CT.

Gears can be molded of many engineering plastics in various grades and in filled varieties. **Filled plastics** are those in which a material has been added to improve the mechanical properties. The additives normally used in gear plastics are glass, polytetrafluoroethylene (PTFE), silicones, and molybdenum disulphide. Glass fiber reinforcement can double the tensile strength and reduce the thermal expansion. Carbon fiber is often used to increase strength. Silicones, PTFE, and molybdenum disulphide are used to act as built-in lubricants and provide increased wear resistance. Plastic gears are designed in the same manner as gears made from other materials. However, the

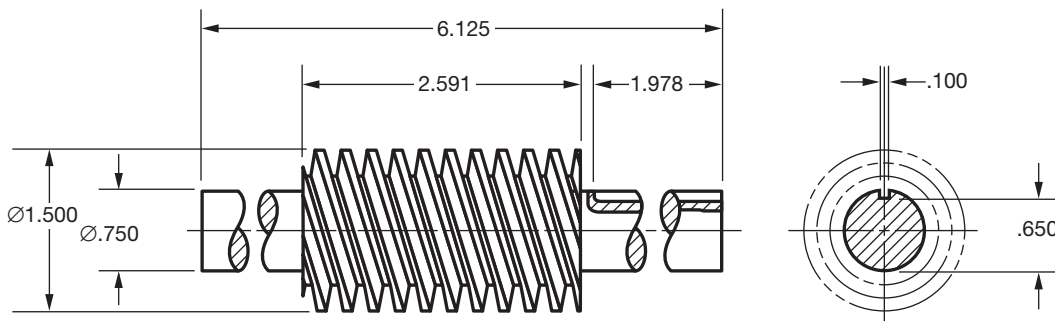


- NOTES:
1. DIMENSIONS AND TOLERANCES PER ASME Y14.5-2009.
  2. INTERPRET GEAR DATA PER ANSI Y14.7.1.
  3. PITCH TOLERANCE  $\pm .002$ .

WORM GEAR DATA	
NUMBER OF TEETH	27
PITCH DIAMETER	2.933
ADDENDUM	.057
WHOLE DEPTH	.114
TOOTH THICKNESS	.100

© Cengage Learning 2012

FIGURE 16.71 A detailed drawing of a worm gear. Dimension values in this figure are in inches.



WORM GEAR DATA	
PITCH DIAMETER	1.251
LEAD RIGHT OR LEFT	RIGHT
CENTER DISTANCE	1.858
WORKING DEPTH	.218
CLEARANCE	.0312
PRESSURE ANGLE	20°
ADDENDUM	.125
WHOLE DEPTH	.25
CHORDAL THICKNESS	.125

- NOTES:
1. INTERPRET GEAR DATA PER ANSI Y14.7.1.
  2. PITCH TOLERANCE  $\pm .002$ .

FIGURE 16.72 A detailed drawing of a worm. Dimension values in this figure are in inches. © Cengage Learning 2012

physical characteristics of plastics make it necessary to follow gear design practices more closely than when designing gears that are machined from metals.

### Advantages of Molded Plastic Gears

Gears molded of plastic are replacing stamped and cut metal gears in a wide range of mechanisms. Designers are turning

to molded plastic gears for one or more of the following reasons:

- Reduced cost.
- Increased efficiency.
- Self-lubrication.
- Increased tooth strength with nonstandard pressure angles.
- Reduced weight.
- Corrosion resistance.
- Less noise.
- Available in colors.

## Disadvantages of Molded Plastic Gears

Plastic gearing has the following limitations when compared with metal gearing:

- Lower strength.
- Greater thermal expansion and contraction.
- Limited heat resistance.
- Size change with moisture absorption.

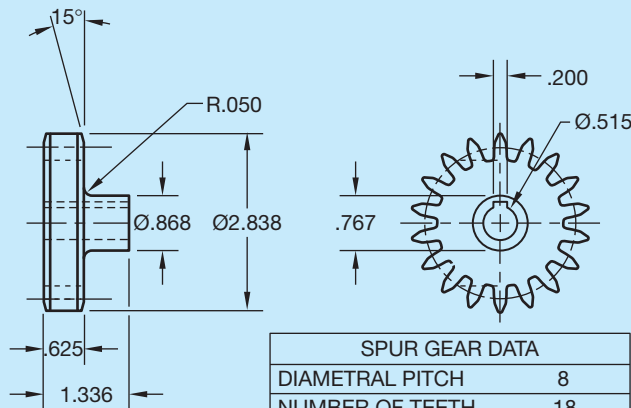
## Accuracy of Molded Plastic Gears

Technology permits a very high degree of precision when manufacturing plastic gears. In general, tooth-to-tooth composite tolerances can be economically held to .0005 or less for fine pitch gears. Total composite tolerance varies depending on configuration, evenness of product cross section, and the selection of the molding material.

### GEAR DRAWINGS AND ANALYSIS

Specialized CADD programs will allow you to model or draw gears or gear teeth by specifying variables. Common variables for gear tooth design include:

- Pitch.
- Diameter.



**NOTES:**

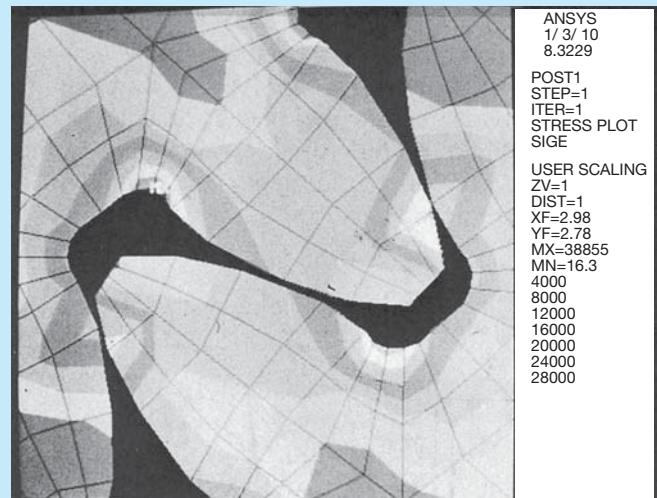
1. DIMENSIONS AND TOLERANCES PER ASME Y14.5-2009.
2. INTERPRET GEAR DATA PER ANSI Y14.7.1.
3. ALL TOOTH ELEMENT SPECIFICATIONS ARE FROM DATUM A.
4. PITCH TOLERANCE .003.
5. PROFILE TOLERANCE .003.

**FIGURE 16.73** Gear detailed drawing using CADD to automatically draw teeth and gear data chart from given specification. Dimension values in this figure are in inches. © Cengage Learning 2012

- Diametral pitch.
- Pressure angle.
- Number of teeth.

The program automatically notifies you if the information is accurate, provides all additional data, and creates a detail drawing of the gear. CADD was used to draw the teeth in the gear detail drawing in Figure 16.73. You can easily draw gears displayed in detailed representation or use the simplified technique to save regeneration and plotting time.

Some software programs do more than assist in the design and drafting process. For example, objects such as gear teeth can be subjected to simulated tests and stress analysis on the computer screen as shown in Figure 16.74.



**FIGURE 16.74** Objects such as these gear teeth can be subjected to simulated tests and stress analysis on the computer screen. Courtesy Swanson Analysis Systems, Inc.

## BEARINGS

**Bearings** are mechanical devices used to reduce friction between two surfaces. They are divided into two large groups known as plain and rolling element bearings. Bearings are designed to accommodate either rotational or linear motion. **Rotational bearings** are used for **radial loads**, and **linear bearings** are designed for **thrust loads**. Radial loads are loads that are distributed around the shaft. Thrust loads are lateral. Thrust loads apply force to the end of the shaft. Figure 16.75 shows the relationship between rotational and linear motion.

### Plain Bearings

**Plain bearings** are often referred to as **sleeve**, **journal bearings**, or **bushings**. Their operation is based on a sliding action between mating parts. A clearance fit between the inside diameter of the bearing and the shaft is critical to ensure proper operation. Refer to fits between mating parts in Chapter 10 for more information. The bearing has an interference fit between the outside of the bearing and the housing or mounting device as shown in Figure 16.76.

The material from which plain bearings are made is important. Most plain bearings are made from bronze or phosphor bronze. Bronze bearings are normally lubricated, whereas phosphor bronze bearings are commonly impregnated with oil and

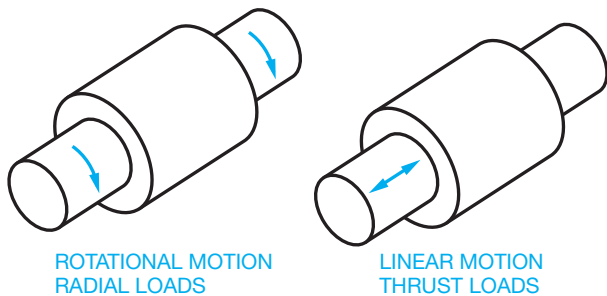


FIGURE 16.75 Radial and thrust loads.

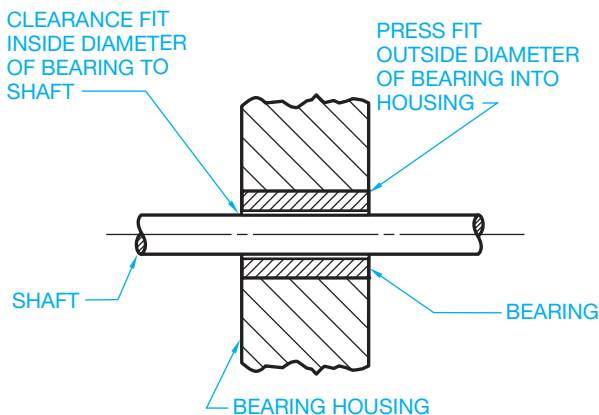


FIGURE 16.76 Plain bearing terminology and fits.

require no additional lubrication. Phosphor bronze is an excellent choice when antifriction qualities are important and where resistance to wear and scuffing are needed.

### Rolling Element Bearings

**Ball** and **roller bearings** are the two classes of rolling element bearings. Ball bearings are the most commonly used rolling element bearings. In most cases, ball bearings have higher speed and lower load capabilities than roller bearings. Even so, ball bearings are manufactured for most uses. Ball bearings are constructed with two grooved rings, a set of balls placed radially around the rings, and a separator that keeps the balls spaced apart and aligned as shown in Figure 16.77.

**Single-row ball bearings** are designed primarily for radial loads, but they can accept some thrust loads. **Double-row ball bearings** may be used where shaft alignment is important. **Angular contact ball bearings** support a heavy thrust load and a moderate radial load. **Thrust bearings** are designed for use in thrust load situations only. When both thrust and radial loads are necessary, both radial and thrust ball bearings are used together. Some typical ball bearings are shown in Figure 16.78.

Ball bearings are available with shields and seals. A **shield** is a metal plate on one or both sides of the bearing. The shields act to keep the bearing clean and retain the lubricant. A **sealed bearing** has seals made of rubber, felt, or plastic placed on the outer and inner rings of the bearing. The sealed bearings are filled with special lubricant by the manufacturer. They require

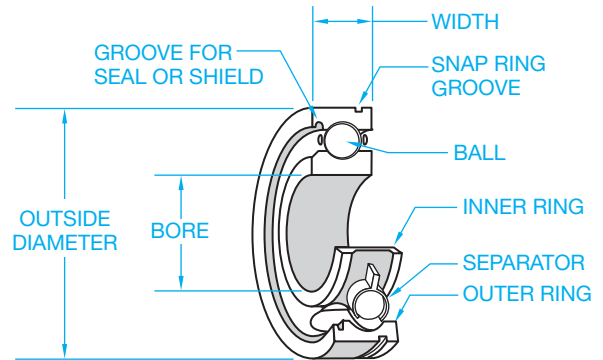


FIGURE 16.77 Ball bearing components.

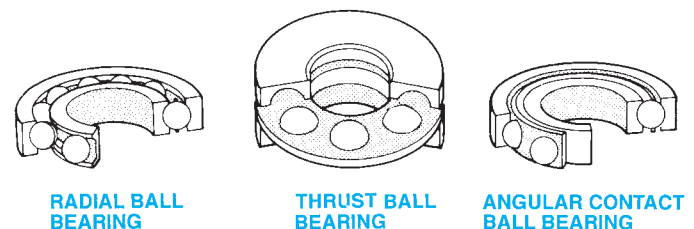


FIGURE 16.78 Typical ball bearings. © Cengage Learning 2012

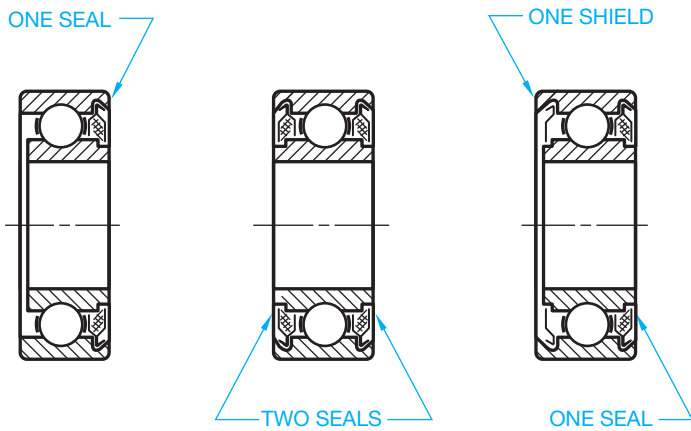


FIGURE 16.79 Bearing seals and shields. © Cengage Learning 2012

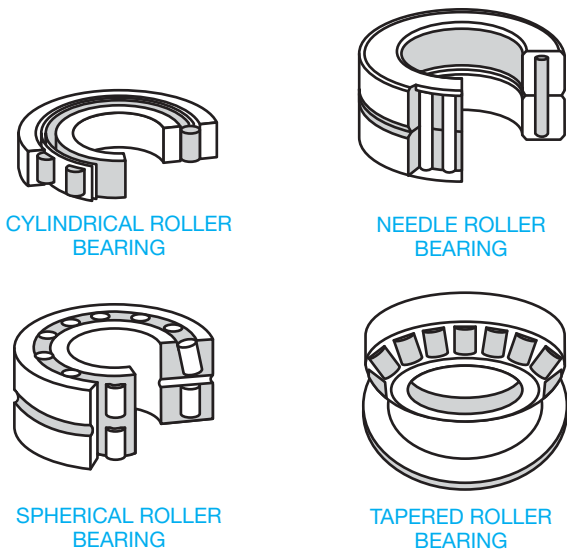


FIGURE 16.80 Typical roller bearings.

little or no maintenance in service. Figure 16.79 shows the shields and seals used on ball bearings.

Roller bearings are more effective than ball bearings for heavy loads. **Cylindrical roller bearings** have a high radial capacity and assist in shaft alignment. **Needle roller bearings** have small rollers and are designed for the highest load-carrying capacity of all rolling element bearings with shaft sizes less than 10 in. **Tapered roller bearings** are used in gear reducers, steering mechanisms, and machine tool spindles. **Spherical roller bearings** offer the best combination of high load capacity, tolerance to shock, and alignment, and they are used on conveyors, transmissions, and heavy machinery. Some common roller bearings are displayed in Figure 16.80.

## DRAWING BEARING SYMBOLS

Only engineering drafters who work for a bearing manufacturer normally make detailed drawings for roller or ball bearings. In most other industries, bearings are not drawn in detail because

BALL BEARINGS			ROLLER BEARINGS			
RADIAL	ANGULAR CONTACT	THRUST	CYLINDRICAL	SPHERICAL	TAPERED	NEEDLE

FIGURE 16.81 Bearing symbols drawn using CADD. © Cengage Learning 2012

they are purchase parts. When bearings are drawn as a representation on assembly drawings or product catalogs, they are displayed using symbols with specific detail required by your company or school.

When CADD is used, the bearing symbols can be drawn and saved in a symbols library for immediate use at any time. This use of CADD helps increase productivity and accuracy over other drafting techniques. Figure 16.81 shows bearing symbols used for a variety of applications.

## BEARING CODES

Bearing manufacturers use similar coding systems for the identification and ordering of different bearing products. The **bearing codes** generally contain the following type of information:

- Material.
- Bearing type.
- Bore size.
- Lubricant.
- Type of seals or shields.

Figure 16.82 shows a sample bearing numbering system.

## BEARING SELECTION

A variety of bearing types are available from manufacturers. Bearing design differs, depending on use requirements. For example, suppliers have light, medium, and heavy bearings available. Bearings have specially designed outer and inner rings. Bearings are available open without seals or shields or with one or two shields or seals. **Light bearings** are generally designed to accommodate a wide range of applications involving light to medium loads combined with relatively high speeds. **Medium bearings** have heavier construction than light bearings and provide a greater radial and thrust capacity. They are also able to withstand greater shock than light bearings. **Heavy bearings** are often designed for special service where extra heavy shock loads are required. Bearings are also designed to accommodate radial loads, thrust loads, and a combination of loading requirements.

## Bearing Bore, Outside Diameters, and Width

Bearings are dimensioned in relation to the **bore diameter**, **outside diameter**, and **width**. These dimensions are shown in Figure 16.83. After the loading requirements have been established,

Wide Inner Ring Bearings

prefixes:

basic series and additional features

- C concentric collar
- E metric bore
- G relubricatable
- 1 standard series
- N heavy series
- RA extended inner ring, one side only
- SM standard series (200 series bearings)
- SMN heavy series (300 series bearings)
- YA set screw locking device

suffixes:

internal construction

- K Conrad, non-filling slot type
- W maximum capacity filling slot type



numbers:

last three numbers indicate bore size — first in inches, last two in sixteenths

- 015 15/16"
- 103 1-3/16"
- 203 2-3/16"
- 25 25 mm (metric)
- 40 40 mm (metric)

additional features:

- L one Mechani-Seal
- LL two Mechani-Seals
- PP two seals
- R one land riding rubber seal
- RR two land riding rubber seals
- B spherical outside diameter
- S external self-aligning
- PP2,3,4, etc. — Tri-Ply seals if preceded by K

FIGURE 16.82 A sample bearing numbering system.

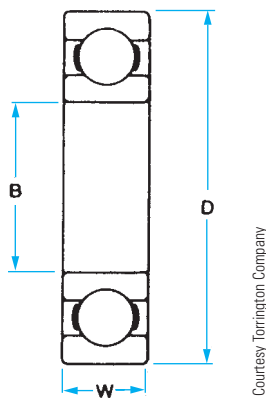


FIGURE 16.83 Bearing dimensions.

the bearing is selected in relationship to the shaft size. For example, if an approximate Ø1.5 IN shaft size is required for a medium service bearing, then a vendor’s catalog chart, similar to the one shown in Figure 16.84, is used to select the bearing.

Referring to the chart in Figure 16.84, notice the first column is the vendor’s bearing number, followed by the bore size (B). To select a bearing for an approximate 1.5 IN shaft, go to the chart and pick the bore diameter of 1.5748, which is close to 1.5. This is the 308K bearing. The tolerance for this bore is specified in the chart as 1.5748 + .0000 and – .0005. Therefore,

the limits dimension of the bore in this example is 1.5748 – 1.5743. The outside diameter is 3.5433 + .0000 – .0006, resulting in this limits dimension value: 3.5433 – 3.5427. The width of this bearing is .906 + .000 – .005, resulting in this limits dimension value: .906 – .901. The fillet radius is the maximum shaft or housing fillet radius in which the bearing corners clear. The fillet radius for the 308K bearing is R.059. Notice the dimensions are also given in millimeters.

Shaft and Housing Fits

Shaft and housing fits are important, because tight fits can cause failure of the balls, rollers, lubricant, or overheating. Loose fits can cause slippage of the bearing in the housing, resulting in overheating, vibration, or excessive wear.

Shaft Fits

In general, for precision bearings, it is recommended that the shaft diameter and tolerance be the same as the bearing bore diameter and tolerance. The shaft diameter used with the 308K bearing is dimensioned Ø1.5748 – 1.5743.

Housing Fits

In most applications with rotating shafts, the outer ring is stationary and should be mounted with a push of the hand or light press. In general, the minimum housing diameter is .0001 larger

DIMENSIONS — TOLERANCES																		
Bearing Number	Bore B				Outside Diameter D				Width W		Fillet Radius <sup>(1)</sup>	WL		Static Load Rating C <sub>0</sub>		Extended Dynamic Load Rating C <sub>1</sub>		
	tolerance +.0000" +.000 mm to minus				tolerance +.0000" +.000 mm to minus				+.000" -.005" +.00 mm - 13 mm									
	in.	mm	in.	mm	in.	mm	in.	mm	in.	mm	.in	mm	lbs.	kg	lbs.	N	lbs.	N
<b>300K</b>	.3937	10	.0003	.008	1.3780	35	.0005	.013	.433	11	.024	.6	.12	.054	850	3750	2000	9000
<b>301K</b>	.4724	12	.0003	.008	1.4567	37	.0005	.013	.472	12	.039	1.0	.14	.064	850	3750	2080	9150
<b>302K</b>	.5906	15	.0003	.008	1.6535	42	.0005	.013	.512	13	.039	1.0	.18	.082	1270	5600	2900	13200
<b>303K</b>	.6693	17	.0003	.008	1.8504	47	.0005	.013	.551	14	.039	1.0	.24	.109	1460	6550	3350	15000
<b>304K</b>	.7874	20	.0004	.010	2.0472	52	.0005	.013	.591	15	.039	1.0	.31	.141	1760	7800	4000	17600
<b>305K</b>	.9843	25	.0004	.010	2.4409	62	.0005	.013	.669	17	.039	1.0	.52	.236	2750	12200	5850	26000
<b>306K</b>	1.1811	30	.0004	.010	2.8346	72	.0005	.013	.748	19	.039	1.0	.78	.354	3550	15600	7500	33500
<b>307K</b>	1.3780	35	.0005	.013	3.1496	80	.0005	.013	.827	21	.059	1.5	1.04	.472	4500	20000	9150	40500
<b>308K</b>	1.5748	40	.0005	.013	3.5433	90	.0006	.015	.906	23	.059	1.5	1.42	.644	5600	24500	11000	49000
<b>309K</b>	1.7717	45	.0005	.013	3.9370	100	.0006	.015	.984	25	.059	1.5	1.90	.862	6700	3000	13200	58500
<b>310K</b>	1.9685	50	.0005	.013	4.3307	110	.0006	.015	1.063	27	.079	2.0	2.48	1.125	8000	35500	15300	68000
<b>311K</b>	2.1654	55	.0006	.015	4.7244	120	.0006	.015	1.142	29	.079	2.0	3.14	1.424	9500	41500	18000	80000
<b>312K</b>	2.3622	60	.0006	.015	5.1181	130	.0008	.020	1.220	31	.079	2.0	3.89	1.765	10800	48000	20400	90000

<sup>(1)</sup>Maximum shaft or housing fillet radius which bearing corners will clear.

FIGURE 16.84 Bearing selection chart. Courtesy Torrington Company

than the maximum bearing outside diameter, and the maximum housing diameter is .0003 larger than the minimum housing diameter. With this in mind, the housing diameter for the 308K bearing is  $3.5433 + .0001 = 3.5434$  and  $3.5434 + .0003 = 3.5437$ . The housing diameter limits are  $3.5437 - 3.5434$ .

### The Shaft Shoulder and Housing Shoulder Dimensions

Next, size the shaft shoulder and housing shoulder diameters. The shaft shoulder and housing shoulder diameter dimensions are represented in Figure 16.85 as S and H. The shoulders should be large enough to rest flat on the face of the bearing and small enough to allow bearing removal. Refer to the chart in Figure 16.86 to determine the shaft shoulder and housing shoulder diameters for the 308K bearing selected in

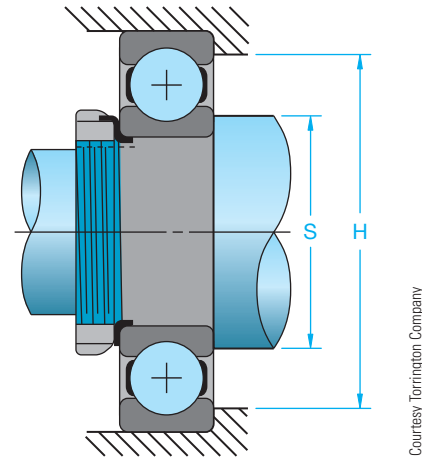
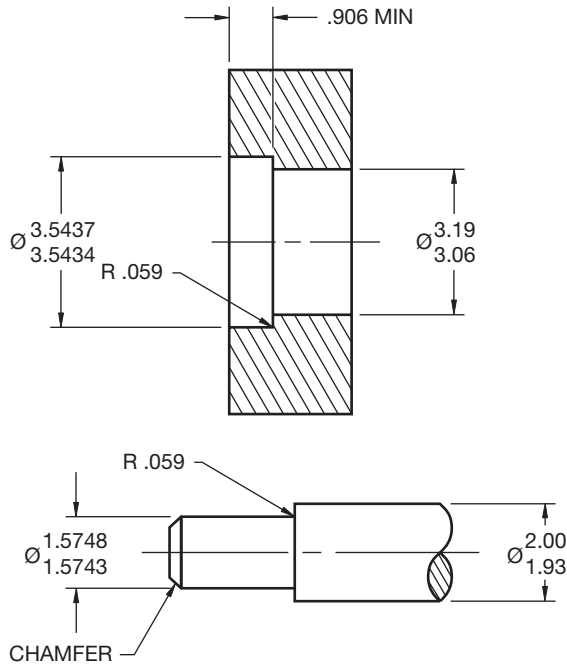


FIGURE 16.85 Shaft shoulder and housing shoulder dimensions.

Extra Light • 9100WN								Light • 200, 7200WN Series								Medium • 300, 7300WN Series										
Basic Bearing Number	Shoulder Diameters				Basic Bearing Number	Shoulder Diameters				Basic Bearing Number	Shoulder Diameters															
	shaft, S		housing, H			shaft, S		housing, H			shaft, S		housing, H													
	max.	min.	max.	min.	max.	min.	max.	min.	max.	min.	max.	min.	max.	min.	max.	min.										
	in.	mm	in.	mm	in.	mm	in.	mm	in.	mm	in.	mm	in.	mm	in.	mm										
<b>9100</b>	.52	13.2	.47	11.9	.95	24.1	.91	23.1	<b>200</b>	.56	14.2	.50	12.7	.98	24.9	.97	24.6	<b>300</b>	.59	15.0	.50	12.7	1.18	30.0	1.15	29.2
<b>9101</b>	.71	18.0	.55	14.0	1.02	25.9	.97	24.6	<b>201</b>	.64	16.3	.58	14.7	1.06	26.9	1.05	26.7	<b>301</b>	.69	17.5	.63	16.0	1.22	31.0	1.21	30.7
<b>9102</b>	.75	19.0	.67	17.0	1.18	30.0	1.13	28.7	<b>202</b>	.75	19.0	.69	17.5	1.18	30.0	1.15	29.2	<b>302</b>	.81	20.6	.75	19.0	1.42	36.1	1.40	35.6
<b>9103</b>	.81	20.6	.75	19.0	1.30	33.0	1.25	31.8	<b>203</b>	.84	21.3	.77	19.6	1.34	34.0	1.31	33.3	<b>303</b>	.91	23.1	.83	21.1	1.61	40.9	1.60	40.6
<b>9104</b>	.98	24.9	.89	22.6	1.46	37.1	1.41	35.8	<b>204</b>	1.00	25.4	.94	23.9	1.61	40.9	1.58	40.1	<b>304</b>	1.06	26.9	.94	23.9	1.77	45.0	1.75	44.4
<b>9105</b>	1.18	30.0	1.08	27.4	1.65	41.9	1.60	40.6	<b>205</b>	1.22	31.0	1.14	29.0	1.81	46.0	1.78	45.2	<b>305</b>	1.31	33.3	1.14	29.0	2.17	55.1	2.09	53.1
<b>9106</b>	1.38	35.1	1.34	34.0	1.93	49.0	1.88	47.8	<b>206</b>	1.47	37.3	1.34	34.0	2.21	56.1	2.16	54.9	<b>306</b>	1.56	39.6	1.34	34.0	2.56	65.0	2.44	62.0
<b>9107</b>	1.63	41.4	1.53	38.9	2.21	56.1	2.15	54.6	<b>207</b>	1.72	43.7	1.53	38.9	2.56	65.0	2.47	62.7	<b>307</b>	1.78	45.2	1.69	42.9	2.80	71.1	2.72	69.1
<b>9108</b>	1.81	46.0	1.73	43.9	2.44	62.0	2.39	60.7	<b>208</b>	1.94	49.3	1.73	43.9	2.87	72.9	2.78	70.6	<b>308</b>	2.00	50.8	1.93	49.0	3.19	81.0	3.06	77.7
<b>9109</b>	2.03	51.6	1.94	49.3	2.72	69.1	2.67	67.8	<b>209</b>	2.13	54.1	1.94	49.3	3.07	78.0	2.97	75.4	<b>309</b>	2.28	57.9	2.13	54.1	3.58	90.9	3.41	86.6
<b>9110</b>	2.22	56.4	2.13	54.1	2.91	73.9	2.86	72.6	<b>210</b>	2.34	59.4	2.13	54.1	3.27	83.1	3.17	80.5	<b>310</b>	2.50	63.5	2.36	59.9	3.94	100.1	3.75	95.2
<b>9111</b>	2.48	63.0	2.33	59.2	3.27	83.1	3.22	81.8	<b>211</b>	2.54	64.5	2.41	61.2	3.68	93.5	3.56	90.4	<b>311</b>	2.75	69.8	2.56	65.0	4.33	110.0	4.13	104.9
<b>9112</b>	2.67	67.8	2.53	64.3	3.47	88.1	3.42	86.9	<b>212</b>	2.81	71.4	2.67	67.8	3.98	101.1	3.87	98.3	<b>312</b>	2.94	74.7	2.84	72.1	4.65	118.1	4.44	112.8

FIGURE 16.86 Shaft shoulder and housing shoulder dimension selection chart. Courtesy Torrington Company



© Cengage Learning 2012

**FIGURE 16.87** A partial detail drawing of the shaft and housing for the 308K bearing. Dimension values in this figure are in inches.

the preceding discussion. Find the basic bearing number 308 and determine the limits of the shaft shoulder and the housing shoulder. The shaft shoulder diameter is 2.00 – 1.93 and the housing shoulder diameter is 3.17 – 3.06. Now you are ready to detail the bearing location on the housing and shaft drawings. Figure 16.87 shows a partial detailed drawing of the shaft and housing for the 308K bearing.

### Surface Finish of Shaft and Housing

The recommended **surface finish** for precision bearing applications is 32 microinches (0.80 micrometer) for the shaft finish on shafts less than 2 in. (50 mm) in diameter. For shafts more than 2 in. in diameter, a 63 microinch (1.6 micrometer) finish is suggested. The housing diameter can have a 125 microinch (3.2 micrometer) finish for all applications.

### Bearing Lubrication

It is necessary to maintain a film of lubrication between the bearing surfaces. The factors to consider when selecting lubrication requirements include the following:

- Type of operation, such as continuous or intermittent.
- Service speed in rpm.
- Bearing load, such as light, medium, or heavy.

Bearings can also be overlubricated, which can cause increased operating temperatures and early failure. Selection of the proper lubrication for the application should be determined

### Oil Viscosities and Temperature Ranges for Ball Bearing Lubrication

Maximum Temperature Range Degrees F	Optimum Temperature Range Degrees F	Speed Factor, $S_i$ (inner race bore diameter (inches) × RPM)	
		Under 1000	Over 1000
		Viscosity	
-40 to +100	-40 to -10	80 to 90 SSU (at 100 deg. F)	70 to 80 SSU (at 100 deg. F)
-10 to +100	-10 to +30	100 to 115 SSU (at 100 deg. F)	80 to 100 SSU (at 100 deg. F)
+30 to +150	+30 to +150	SAE 20	SAE 10
+30 to +200	+150 to +200	SAE 40	SAE 30
+50 to +300	+200 to +300	SAE 70	SAE 60

**FIGURE 16.88** Selection of oil viscosity based on temperature ranges and speed factors. © Cengage Learning 2012

by the manufacturer recommendations. The ability of the lubricant is due, in part, to **viscosity**. Viscosity is the internal friction of a fluid, which makes it resist a tendency to flow. Fluids with low viscosity flow more freely than fluids with high viscosity. The chart in Figure 16.88 shows the selection of oil viscosity based on temperature ranges and speed factors.

### Oil Grooving of Bearings

In situations when bearings or bushings do not receive proper lubrication, it can be necessary to provide grooves for the proper flow of lubrication to the bearing surface. The bearing grooves help provide the proper lubricant between the bearing surfaces and maintain cooling. There are several methods of designing paths for the lubrication to the bearing surfaces, as shown in Figure 16.89.

### Sealing Methods

Machine designs normally include means for stopping leakage and keeping out dirt and other contaminants when lubricants are involved in the machine operation. This is accomplished using static or dynamic sealing devices. **Static sealing** refers to stationary devices that are held in place and stop leakage by applied pressure. Static seals such as gaskets do not come into contact with the moving parts of the mechanism. **Dynamic seals** are those such as packings that contact the moving parts of the machinery.

**Gaskets** are made from materials that prevent leakage and access of dust contaminants into the machine cavity. Silicone rubber gasket materials are used in applications such as water pumps, engine filter housings, and oil pans. Gasket tapes, ropes, and strips provide good cushioning properties for dampening vibration, and the adhesive sticks well to most materials. Nonstick gasket materials such as paper, cork, and rubber are available for certain applications. Figure 16.90 shows a typical gasket mounting.



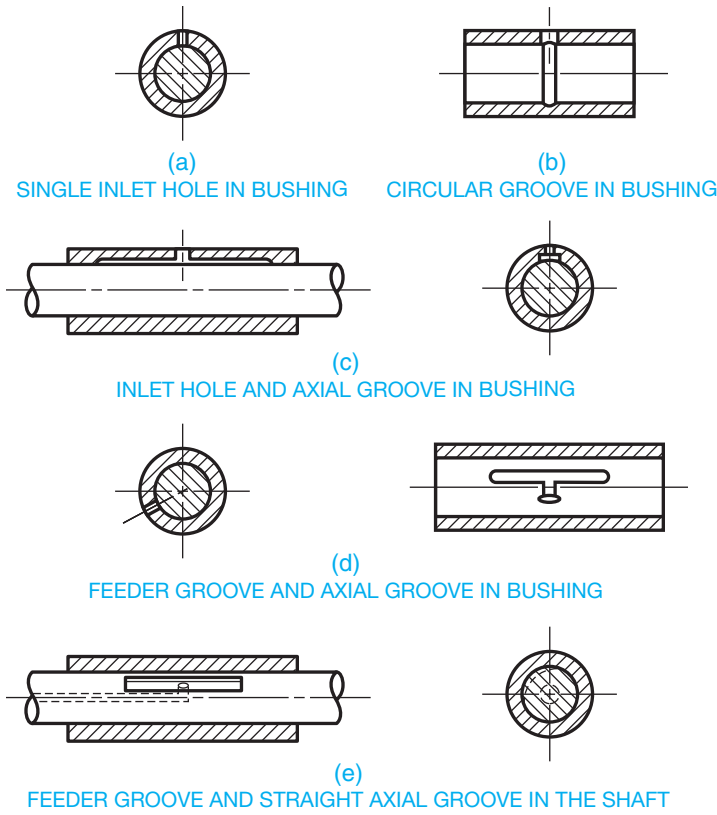


FIGURE 16.89 Methods of designing paths for lubrication to bearing surfaces. © Cengage Learning 2012

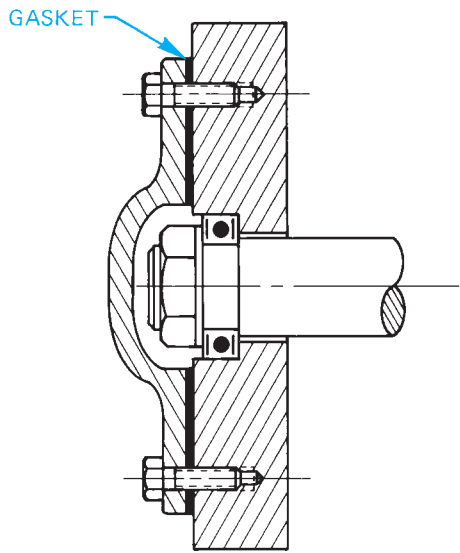


FIGURE 16.90 Typical gasket mounting.

Dynamic seals include packings and seals that fit tightly between the bearing or seal seat and the shaft. The pressure applied by the seal seat or the pressure of the fluid causes the sealing effect. **Molded lip packings** are available that provide sealing as a result of the pressure generated by the machine

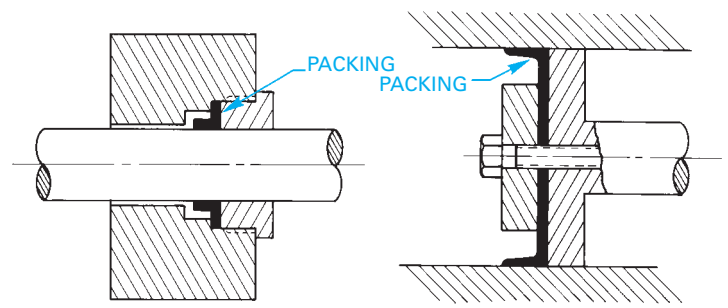


FIGURE 16.91 Molded lip packings. © Cengage Learning 2012

fluid. Figure 16.91 shows examples of molded lip packings. **Molded ring seals** are placed in a groove and provide a positive seal between the shaft and bearing or bushing. Types of molded ring seals include labyrinth, O-ring, lobed ring, and others. **Labyrinth**, which means maze, refers to a seal that is made of a series of spaced strips that are connected to the seal seat, making it difficult for the lubrication to pass. Labyrinth seals are used in heavy machinery where some leakage is permissible (see Figure 16.92). The **O-ring seal** is the most commonly used seal because of its low cost, ease of application, and flexibility. The O-ring can be used for most situations involving rotating or oscillating motion. The O-ring is placed in a groove that is machined in either the shaft or the housing as shown in Figure 16.93. The **lobed ring seal** has rounded lobes that provide

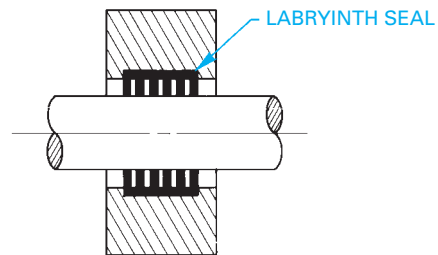


FIGURE 16.92 Labyrinth seal.

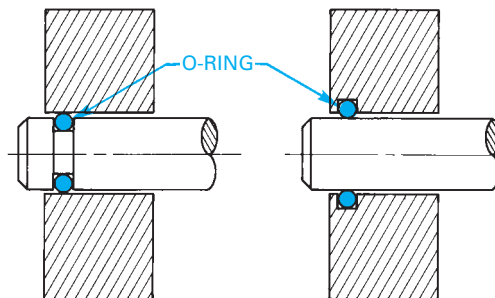


FIGURE 16.93 O-ring seals.

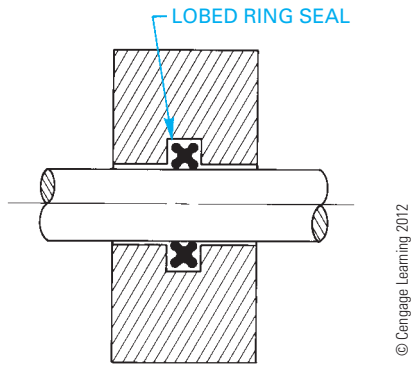


FIGURE 16.94 Lobed ring seal.

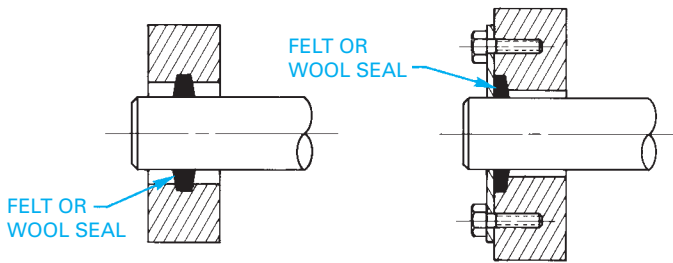


FIGURE 16.95 Felt and wool seals. © Cengage Learning 2012

additional sealing forces over the standard O-ring seal. Figure 16.94 shows a typical lobed ring seal.

Felt seals and wool seals are used where economical cost, lubricant absorption, filtration, low friction, and a polishing action are required. However, the ability to seal the machinery

completely is not as positive as with the seals described earlier (see Figure 16.95).

### Bearing Mountings

There are a number of methods used for holding the bearing in place. Common techniques include a nut and lock washer, a nut and lock nut, and a retaining ring. Other methods can be designed to fit the specific application or requirements, such as a shoulder plate. Figure 16.96 shows some examples of mountings.

### GEAR AND BEARING ASSEMBLIES

Gear and bearing assemblies show the parts of the complete mechanism, as they appear assembled (see Figure 16.97). When drawing assemblies, you need to use as few views as possible but enough views to display how all the parts fit together. In some situations, all that is needed is a full sectional view that displays all of the internal components. An exterior view such as a front or top view plus a section sometimes works. Dimensions are normally omitted from the assembly unless the dimensions are needed for assembly purposes. For example, when a specific dimension regarding the relationship of one part to another is required to assemble the parts properly, each part is identified with a number in a circle. This circle is referred to as a balloon. The balloons are connected to the part being identified with a leader. The balloons are .5 in. (25 mm) in diameter. The identification number is .24 in. high (6 mm) text. The balloon numbers correlate with a parts list. The parts list is normally placed on the drawing above or next to the title

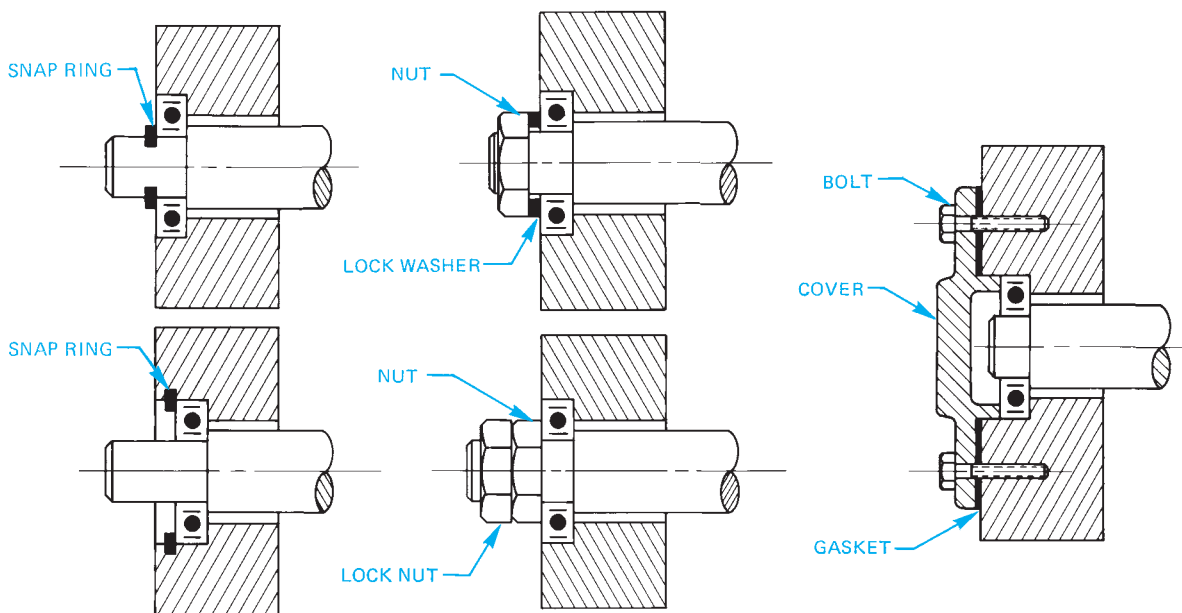
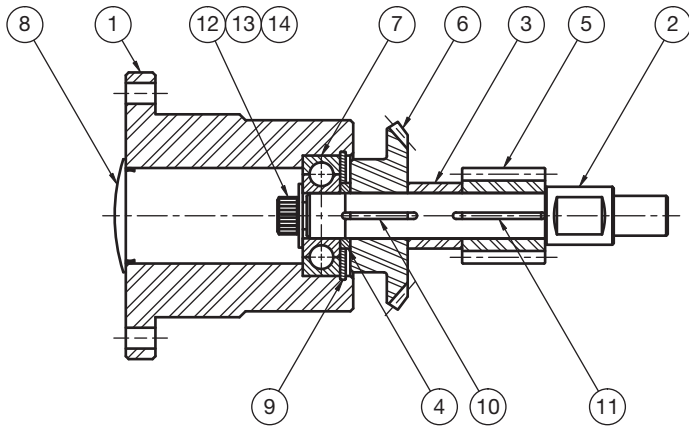



FIGURE 16.96 Typical bearing mountings.



block, or on a separate sheet as shown in Figure 16.98. Assembly includes torque data and lubricant information. Refer to Chapter 18 for complete information covering detail, assembly drawings, and parts lists.

 **Engineering Drawing and Design Math Applications**

For complete information and instructions for engineering drawing and design math applications, go to the Student CD, select **Reference Material**, and **Engineering Drawing and Design Math Applications**.

FIGURE 16.97 Assembly drawing. Courtesy Engineering Drafting & Design, Inc.

ASSEMBLY Cross Shaft Assembly  
 NUMBER OF UNITS \_\_\_\_\_

USED ON \_\_\_\_\_  
 DATE \_\_\_\_\_

HAVE	NEED	P/Ø NO. W/Ø NO.	DET. NO.	PART NO.	DWG.	QTY.	PART NAME	DESCRIPTION	VENDOR
			1		B	1	Bearing Retainer	Ø 3" C.D. Bar	
			2		B	1	Cross Shaft	Ø 3/4" C.D. Bar	
			3		A	1	Spacer	Ø 3/4 O.D. × 11GA Wall Tube × .738 Thick	
			4		A	1	Spacer	Ø 3/4 O.D. × 11GA Wall Tube × .125 Thick	
			5		—	1	Steel Worm 12 D.P. Single Thread	Boston Gear #H 1056 R.H.	
			6		—	1	Bevel Gear 20° P.A. 2" P.D.	Boston Gear #HL 149 Y-G	
			7		—	1	Ball Bearing .4724 Ø Bore	T.R.W. or Equivalent #MRC 201-S22	
			8		—	1	End Plug		
			9		—	1	Snap Ring	Waldes-Truarc #N 5000-125	
			10		—	1	Key Stock	1/8 Sq. × 3/4 Lg.	
			11		—	1	Key Stock	1/8 Sq. × 1 Lg.	
			12		—	1	Socket Head Cap Screw	1/4 UNC × 3/4 Lg.	
			13		—	1	Lockwasher	1/4 Nominal	
			14		—	1	Flat Washer	1/4 Nominal	

FIGURE 16.98 Parts list. Courtesy Engineering Drafting & Design, Inc.

## PROFESSIONAL PERSPECTIVE

In every situation regarding linkage, cam, and gear design, there is a need to investigate all of the manufacturing alternatives and provide a solution the customer can afford. Competition is so great in the manufacturing industry that you should evaluate each design to find the best way to produce the product. The best way to understand this concept as an entry-level engineering drafter is to talk to experienced designers, engineers, and machinists. Go to the shop to see how things are done and determine the drawing requirements directly from the people who know. According to one design engineer, “If you do not know how the product is made, you are not a valuable drafter for the company. Know the manufacturing capabilities of each piece of manufacturing equipment.” In addition to your drafting courses, it is a good idea to take some manufacturing technology classes. Math is also an important part of your program. Drafters in this field use many calculations, including geometry and trigonometry. After you have a strong educational background, the experienced engineer says, “Keep an open mind and look at all the alternatives.”

For example, you work as an engineering drafter for a foundry. For years, the flasks have been handled either by hand or with a lift truck. Both of these methods are time consuming and dangerous, and the company has some contracts that require founding some castings that are too heavy to handle. Therefore, the engineering department plans the

design for a hydraulic flask handler. Your team is responsible for the handling mechanism that must be designed with the following criteria:

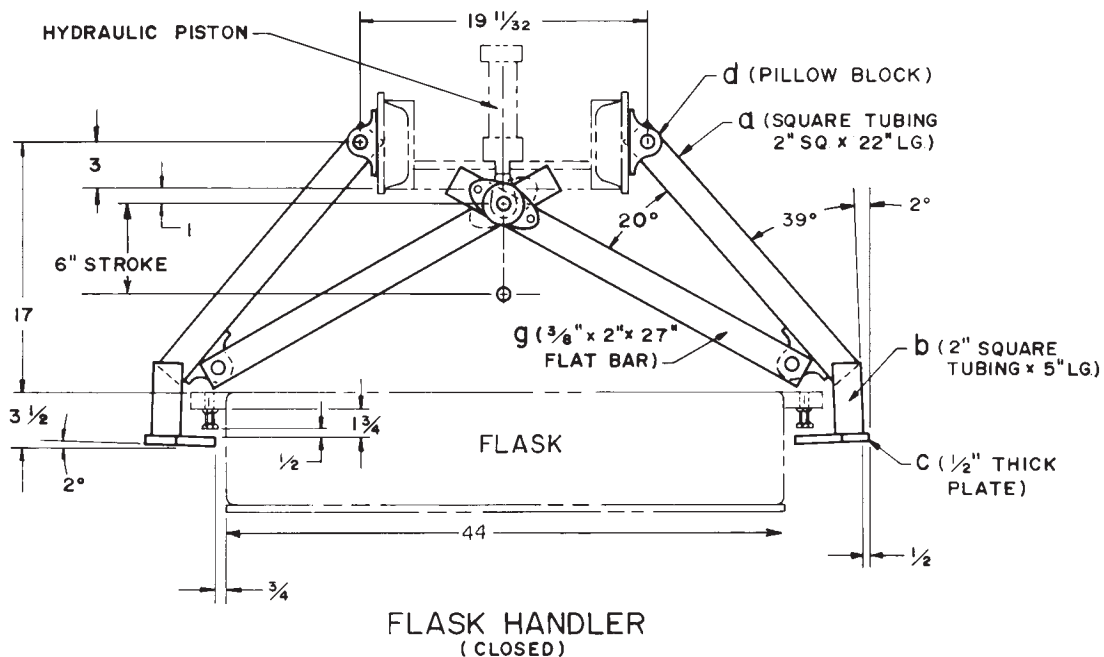
- Use a hydraulic piston with a 6 in. stroke.
- Handle up to 44 in. wide flasks.
- Take up no more than 28 in. in overall height.

Your team begins the problem-solving process and comes up with these steps to solve the problem:

- Develop a single-line schematic kinematic diagram representing the movement of the mechanism based on the design information.
- Identify and locate the available materials needed to build the flask handler.

Figure 16.99 shows the preliminary design. All your team needs to do now is ask the other design teams for input and, after revisions are made, prepare a complete set of working drawings for fabrication.

It is recommended that you review Chapter 4, *Manufacturing Materials and Processes*; Chapter 8, *Multiviews*; Chapter 12, *Sections, Revolutions, and Conventional Breaks*; Chapter 10, *Dimensioning and Tolerancing*; and CD reference material, *Engineering Drawing and Design Math Applications*.



**FIGURE 16.99** A preliminary design is created. Dimension values in this figure are in inches.

## LENGTH OF A CONNECTING ROD

**Problem:** Find the length of the connecting rod for the slider mechanism of Figure 16.100.

**Solution:** Using the law of sines (refer to the following Student CD reference to **Engineering Drawing and Design Math Applications**):

$$\frac{a}{\sin A} = \frac{b}{\sin B}$$

$$\frac{14''}{\sin 20^\circ} = \frac{b}{\sin 60^\circ}$$

Solving this proportional equation for  $b$  gives  $b = 35.4''$ .

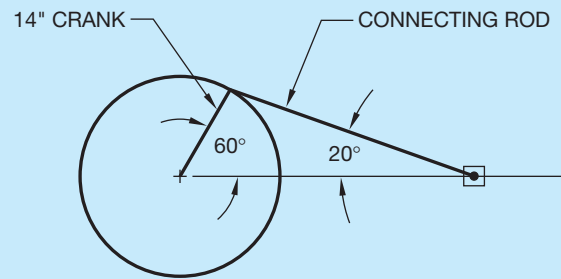


FIGURE 16.100 Slider mechanism. © Cengage Learning 2012

## WEB SITE RESEARCH

Use the following Web sites as a resource to help find more information related to engineering drawing and design and the content of this chapter.

Address	Company, Product, or Service
<a href="http://www.abapgt.com">www.abapgt.com</a>	Plastic gearing technology
<a href="http://www.ansi.org">www.ansi.org</a>	American National Standards Institute (ANSI)
<a href="http://www.asme.org">www.asme.org</a>	American Society of Mechanical Engineers (ASME)
<a href="http://www.gearmfg.com">www.gearmfg.com</a>	American Gear Manufacturers Association
<a href="http://www.industrialpress.com">www.industrialpress.com</a>	<i>Machinery's Handbook</i> . Gear, cam, linkage, and bearing-related information and specifications
<a href="http://www.iso.org">www.iso.org</a>	International Organization for Standardization (ISO)
<a href="http://www.sae.org">www.sae.org</a>	Society of Automotive Engineers (SAE)
<a href="http://www.source4industries.com">www.source4industries.com</a>	Bearings
<a href="http://www.thomasregional.com">www.thomasregional.com</a>	Gear, cam, and bearing products
<a href="http://www.timken.com">www.timken.com</a>	Bearings

# Chapter 16

## Chapter 16 Mechanisms: Linkages, Cams, Gears, and Bearings Test



To access the Chapter 16 test, go to the Student CD, select **Chapter Tests and Problems**, and then **Chapter 16**. Answer the questions

with short, complete statements, sketches, or drawings as needed. Confirm the preferred submittal process with your instructor.

# Chapter 16 Mechanisms: Linkages, Cams, Gears, and Bearings Problems

## INSTRUCTIONS

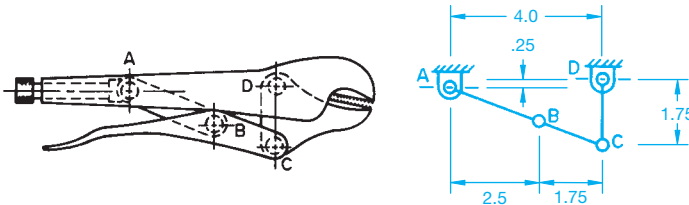
Read problems carefully before you begin working. Complete each problem on an appropriately sized sheet with a border and sheet block of your choice unless otherwise specified by your instructor.

### Linkage Problems

#### Part 1: Problems 16.1 Through 16.14

**PROBLEM 16.1** Refer to the pictorial drawing and a linkage schematic of a vise grip in the closed position. Reproduce the schematic exactly as shown and also show the open position in a second color.

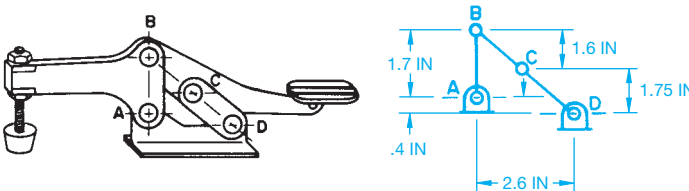
- A-B = 2.5 IN
- B-C = 1.75 IN
- C-D = 1.75 IN
- A-D vertical .25 IN
- A-D horizontal 4.0 IN



© Cengage Learning 2012

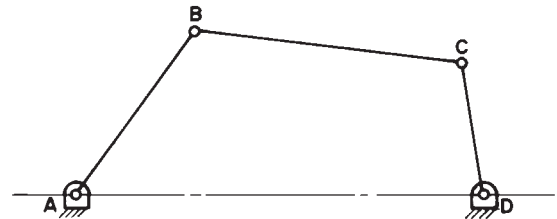
**PROBLEM 16.2** Refer to the pictorial drawing and a linkage schematic of a toggle clamp in the closed position. Reproduce the schematic exactly as shown and also show the open position in a second color.

- A-B = 1.7 IN
- B-C = 1.6 IN
- C-D = 1.75 IN
- A-D vertical .4 IN
- A-D horizontal 2.6 IN



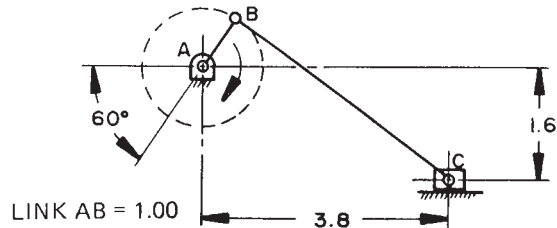
© Cengage Learning 2012

**PROBLEM 16.3** Determine the extreme right and left positions of link CD in the given problem. Determine and label the angle through which CD oscillates. Measure the problem drawing using a 1/2" = 1'-0" scale and transfer the measurements to your final drawing.



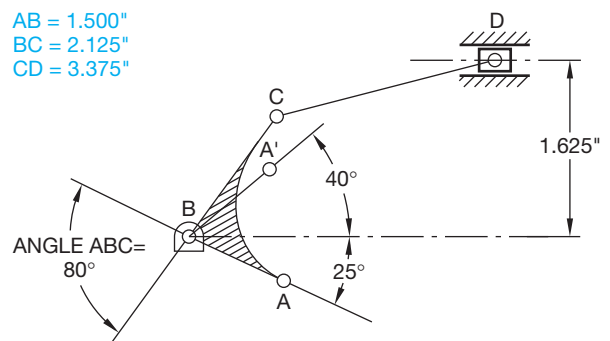
© Cengage Learning 2012

**PROBLEM 16.4** Draw the mechanism in the position shown. Use different colors to draw the mechanism in the extreme right and left positions. Dimension the stroke (in.).



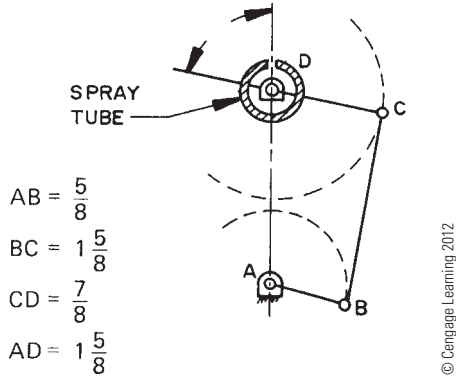
© Cengage Learning 2012

**PROBLEM 16.5** Draw the combination bell crank slider mechanism in the position shown. Determine the stroke of the slider if A moves to position A1. Note: Position of features in the sketch may be out of proportion (in.).

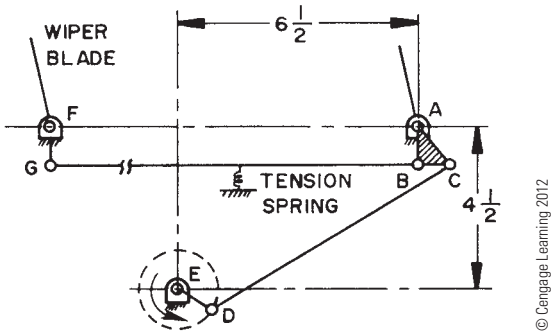


© Cengage Learning 2012

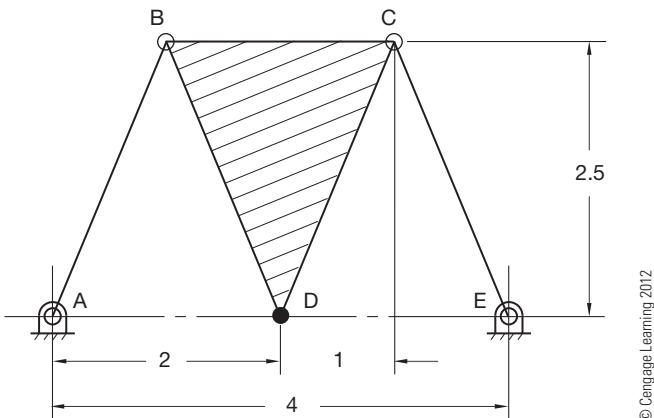
**PROBLEM 16.6** The given drawing is a linkage schematic of an oscillating lawn sprinkler. The spray tube, shown in section, is part of link CD. Link AB moves through 360°, while points A and D are stationary. Determine and dimension the angle of oscillation through which the spray moves (in.).



**PROBLEM 16.7** Given the windshield wiper mechanism, determine and dimension the angle of oscillation of the wiper blades. The electric motor rotates link ED continuously through 360°. ABC is one link with a 90° angle at B. A tension spring is located in the center of link BG.



**PROBLEM 16.8** Draw the given mechanism. Use different colors to show the path of point D in a total of five equally spaced positions, including the extreme right and left positions (in.).



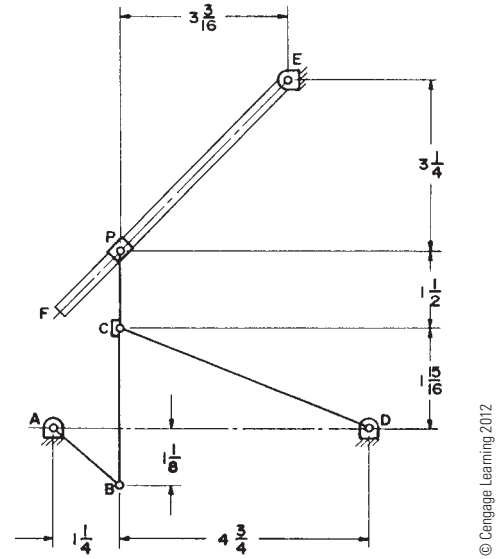
**PROBLEM 16.9** Draw the mechanism in the given position. Draw the path of point P as linkage AB moves every 30° through a total of 360°. Use a different color or line type or both for each position (in.).

Dimension the angle through which CD oscillates.

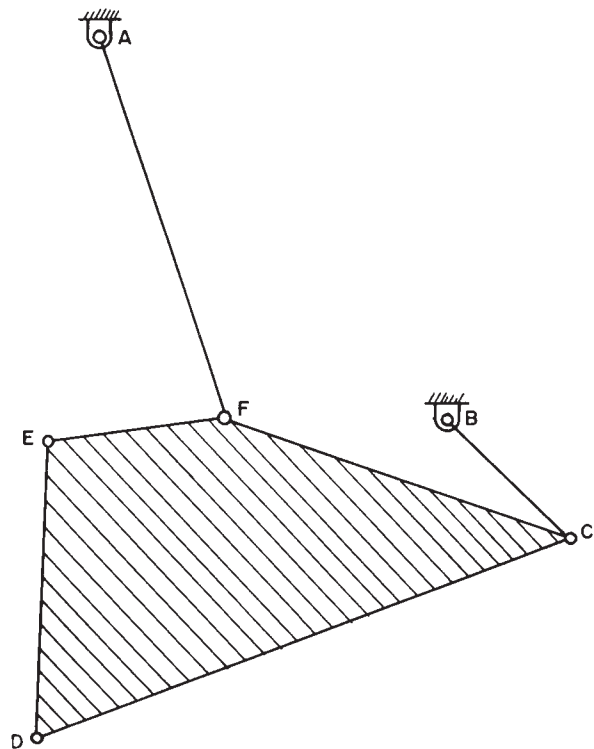
BCP is a through link.

Point P slides on EF.

EF = 6.5 IN

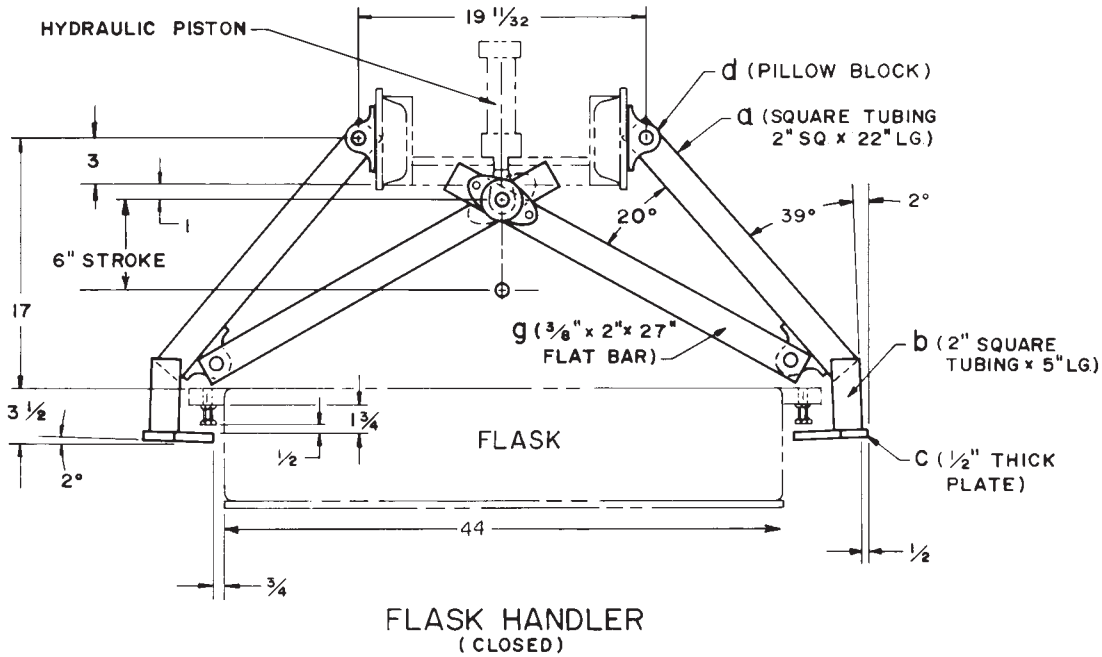


**PROBLEM 16.10** Given the mechanism, rotate link BC at 60° intervals clockwise through 360°. Plot and draw the paths of points D, E, and F. Dimension the angle of oscillation of link AF. Measure the problem drawing using a 1/2" = 1'-0" scale and transfer the measurements to your final drawing.



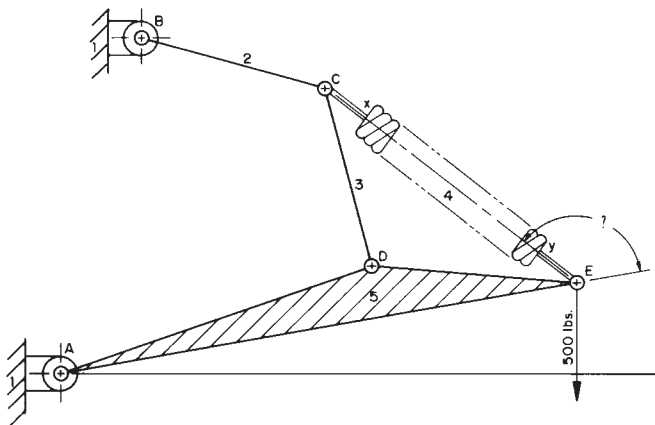
**PROBLEM 16.11** Given the assembly drawing of the foundry flask handler, draw a mechanism schematic showing the two extreme positions of movement. The handler is operated by a hydraulic piston with a 6 IN stroke.

a is welded to b.  
b is welded to c (in.).



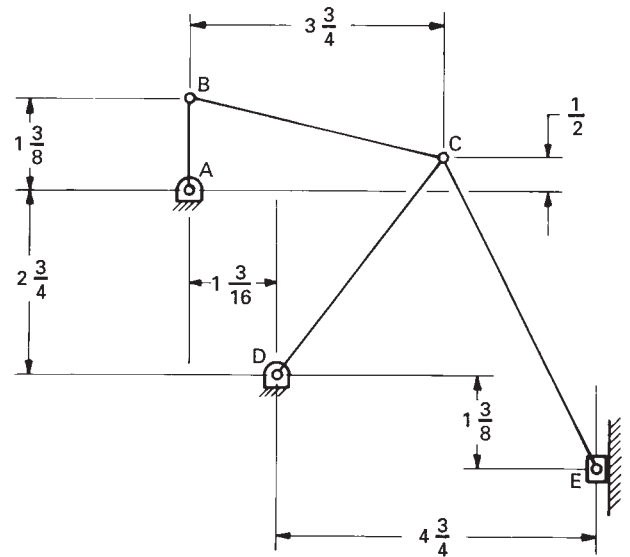
© Cengage Learning 2012

**PROBLEM 16.12** Given the pivot hoist, measure and draw exactly as shown using a 1/4" = 1'-0" scale and transfer the measurements to your final drawing. Rotate ADE clockwise so link AE is horizontal. Determine and dimension the extended length of the spring between C and E. Determine and dimension the angle between AE and CE when E is in the new position.



© Cengage Learning 2012

**PROBLEM 16.13** Given the linkage drawing, determine and dimension the stroke of point E moving in a straight line as link AB rotates 360°. In addition, dimension the angle of oscillation of link CD (in.).



© Cengage Learning 2012



**PROBLEM 16.14** Find two examples of linkage mechanisms at home or school. Explain in a short complete statement the function of each mechanism. Use schematic representations to show and dimension the extreme positions of each mechanism.

## Cam Displacement Diagrams

### Part 2: Problems 16.15 Through 16.25

**PROBLEM 16.15** Construct a cam displacement diagram for a cam follower that rises in simple harmonic motion a total of 2.00 in. in 150°, dwells for 30°, falls 2.00 in. simple harmonic motion in 120°, and dwells for 60°. Draw the horizontal scale 6.00 in.

**PROBLEM 16.16** Construct a cam displacement diagram for a cam follower that rises in uniform accelerated motion a total of 2.00 in. in 180°, dwells for 30°, falls 2.00 in. uniform accelerated motion in 120°, and dwells for 30°. Draw the horizontal scale 6.00 in.

**PROBLEM 16.17** Construct a cam displacement diagram for a cam follower that rises in modified constant velocity for 3.00 in. in 180°, falls 3.00 in. modified constant velocity motion in 120°, and dwells for 60°. Use a modified constant velocity motion designed with one-third of the displacement.

**PROBLEM 16.18** Construct a cam displacement diagram for a cam follower that rises 2.000 in. cycloidal motion in 120°, dwells for 60°, and falls 2.000 in. in cycloidal motion in 180°.

**PROBLEM 16.19** Construct a cam displacement diagram for a cam follower that rises in simple harmonic motion a total of 1.250 in. in 90°, dwells for 60°, rises .750 in. in 45° simple harmonic motion, falls 2.00 in. with cycloidal motion in 120°. Draw the horizontal scale 12 in.

**PROBLEM 16.20** Construct a cam displacement diagram for a cam follower that rises in modified constant velocity motion (modified to one-third the displacement) for 3.000 in. in 180°, dwells for 30°, and falls 3.000 in. simple harmonic motion in 120°, and dwells to the end of the cycle. Draw the horizontal scale 12 in.

**PROBLEM 16.21** Construct a cam displacement diagram for a cam follower that rises 3.500 in. in 90° cycloidal motion, dwells for 45°, falls 2.500 in. cycloidal motion in 135°, dwells for 30°, falls 1.000 in. simple harmonic motion in 30°, and dwells to the end of the cycle. Draw the horizontal scale 12 in.

**PROBLEM 16.22** Construct a cam displacement diagram for a cam follower that rises in cycloidal motion for 3.000 in. in 90°, dwells for 30°, falls 1.000 in. in simple harmonic motion in 90°, dwells for 30°, and falls the remaining 2.000 in. in uniform accelerated motion in 120°. Draw the horizontal scale 12 in.

**PROBLEM 16.23** Construct a cam displacement diagram for a cam follower that rises in cycloidal motion a total of 2.1875 in. in 150°, dwells for 30°, falls back to the original level in simple harmonic motion in 150°, then dwells through the remainder of the cycle. Use a 12 in. horizontal scale.

**PROBLEM 16.24** Construct a cam displacement diagram for a cam follower that rises a .375 in. diameter inline roller follower 1.500 in. in uniform accelerated motion in 150°, dwells 45°, falls with modified constant velocity (one-third displacement) in 120°, and dwells the remainder of the cycle.

**PROBLEM 16.25** Construct a cam displacement diagram for a cam follower that rises 3.500 in. in 90° cycloidal motion, dwells for 30°, falls 2.250 in. cycloidal motion in 150°, falls 1.250 in. simple harmonic motion in 60°, and dwells for 30°. Draw the horizontal scale equal in circumference to a 3.000 in. diameter circle.

## Cam Profile Drawings

### Part 3: Problems 16.26 Through 16.31

1. For the following problems requiring detail drawings, use an appropriate ASME sheet size with border and sheet blocks.
2. Draw and completely dimension the necessary views.
3. Provide a cam displacement chart for cam drawings and gear data chart for gear drawings.
4. Include the following general notes at the lower-left corner of the sheet .5 in. each way from the corner border lines:

### NOTES:

1. DIMENSIONING AND TOLERANCING PER ASME Y14.5-2009.
2. REMOVE ALL BURRS AND SHARP EDGES.

Additional general notes may be required depending on the specifications of each individual assignment. Use the following for tolerances for unspecified inch values. A tolerance block is recommended as described in Chapter 2 and shown in problems for Chapter 10 unless otherwise specified.

UNSPECIFIED TOLERANCES	
DECIMALS	IN
X	±.1
XX	±.01
XXX	±.005
ANGULAR	±30'
FINISH	125 μin.

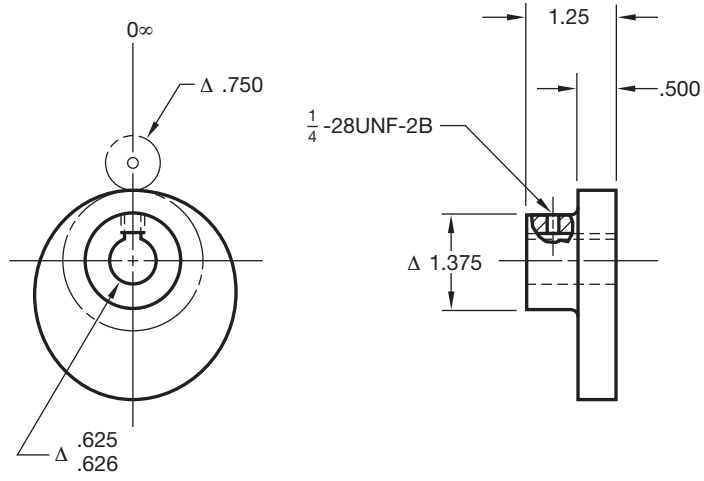
For metric drawings, provide a general note that states TOLERANCES FOR UNSPECIFIED DIMENSIONS COMPLY WITH ISO 2768-m. Provide a general note that states SURFACE FINISH 3.2μm UNLESS OTHERWISE SPECIFIED.



## Drafting Templates

To access CADD template files with predefined drafting settings, go to the Student CD, select **Drafting Templates**, and select the appropriate template file.

**PROBLEM 16.26** Use the displacement diagram constructed in Problem 16.15 and the information given in the illustration to lay out the plate cam profile drawing. The cam rotates counterclockwise. Make a two-view detailed drawing of the cam and dimension it as shown in this chapter (in.).



- INLINE ROLLER FOLLOWER = Δ.750
- BASE CIRCLE = Δ2.000
- KEY SIZE USED = 1/4 □ 1/4 SQ. KEY
- PLATE THICKNESS = .500
- HUB THICKNESS = .750
- HUB DIAMETER = Δ1.375
- SHAFT DIAMETER = Δ.625/.626

© Cengage Learning 2012

**PROBLEM 16.27** Use the displacement diagram constructed in Problem 16.18 and the information given in the illustration for Problem 16.26 to lay out the plate cam profile. The cam is rotating counterclockwise. Make a two-view detailed drawing of the cam, properly dimensioned and toleranced.

**PROBLEM 16.28** Make a two-view detailed drawing of a plate cam using the displacement diagram from Problem 16.24. Completely dimension the drawing using the following information:

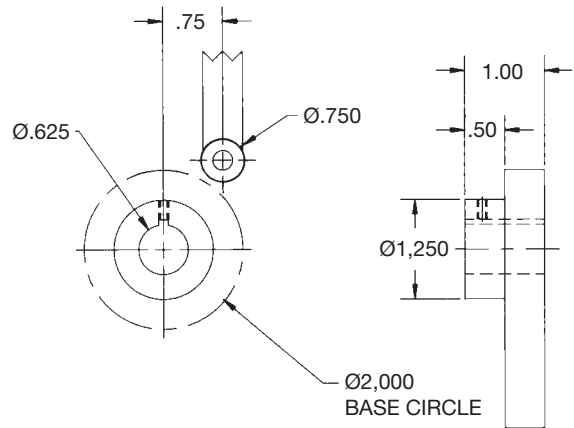
- The cam rotates counterclockwise.
- Inline roller follower = Ø375
- Base circle = Ø2.750
- Shaft = Ø1.000
- Hub diameter = Ø1.250
- Hub projection = .500
- Plate thickness = .375
- All dimensions in inches.

**PROBLEM 16.29** Make a two-view detailed drawing of a plate cam using the displacement diagram from Problem 16.20. Completely dimension the drawing using the following information:

- The cam rotates counterclockwise.
- Inline roller follower = Ø.750

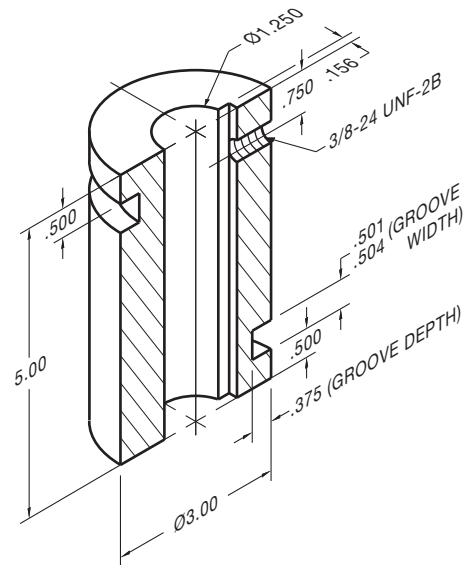
- Base circle = Ø2.000
- Shaft = Ø.625
- Hub diameter = Ø1.250
- Hub projection = .500
- Plate thickness = .500
- All dimensions in inches.

**PROBLEM 16.30** Make a two-view detailed drawing of a plate cam using the displacement diagram from Problem 16.18. Completely dimension the drawing using the information shown below (in.).



© Cengage Learning 2012

**PROBLEM 16.31** Use the displacement diagram constructed in Problem 16.25 and the following illustration to lay out the profile of the groove in the drum cam. The cam rotates clockwise. Make a two-view detailed drawing of the drum cam, with tolerances and dimensions as discussed and shown in this chapter (in.).



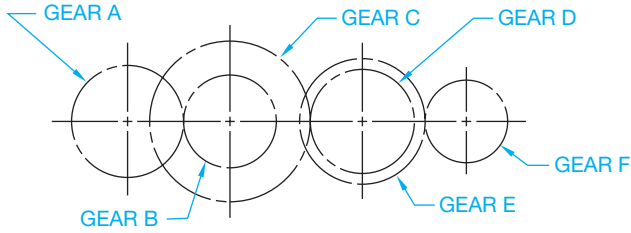
HALF OF OBJECT SHOWN

© Cengage Learning 2012

### Gear Problems

#### Part 4: Problems 16.32 Through 16.37

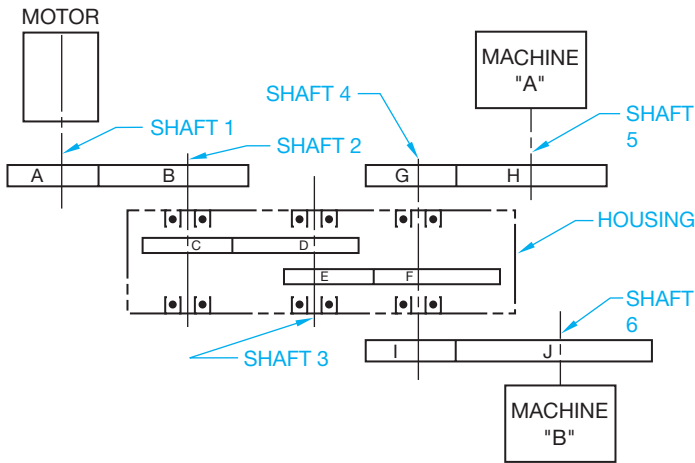
**PROBLEM 16.32** Given the gear train and chart, calculate or determine the missing information to complete the chart.



© Cengage Learning 2012

Gear	Diametral Pitch (P)	Number of Teeth (N)	Pitch Diameter (D)	RPM	Direction	Center Distance	Gear Ratio
A	4		7.5"	240	Clockwise		
B		18					
C			10.0"	400			
D	5	40					
E	7						
F		14		1500			

**PROBLEM 16.33** Given the ten-gear power transmission and chart, calculate or determine the missing information to complete the chart.



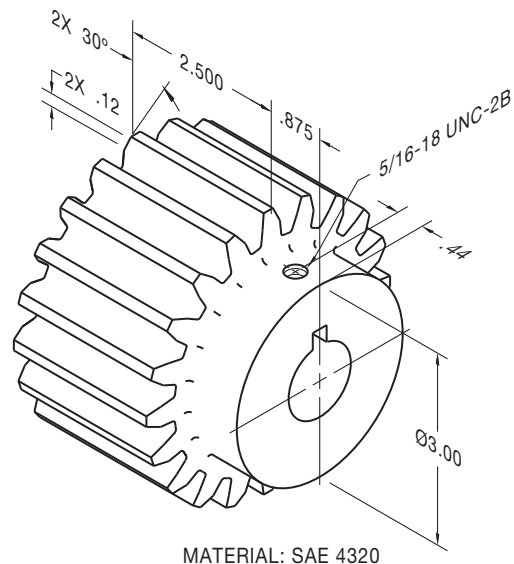
© Cengage Learning 2012

Gear	Pitch Diameter	No. of Teeth	Diametral Pitch	RPM	Ctr. Distance Between Mating Gears	Direction
A	3.00			3600		Counter-clockwise
B			5		4.00	
C		48				
D			12	1080		
E	4.00	40				
F		100				
G	5.00				6.00	
H			6			
I			4			
J		40		108		

**PROBLEM 16.34** Given the following information, use ASME standards to make a detail drawing of the spur gear using the instructions provided with these problems (in.):

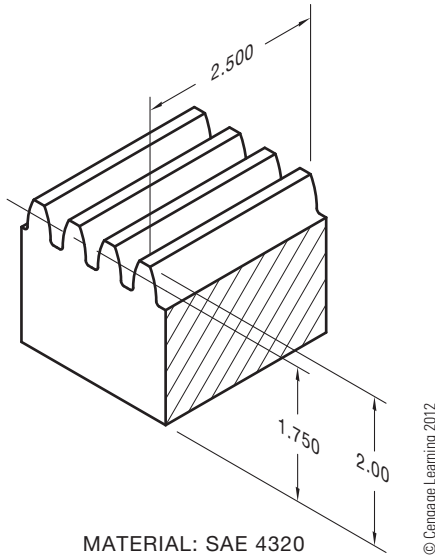
- 20 teeth
- Diametral pitch = 5
- 20° pressure angle
- Face width = 2.500 IN
- Shaft diameter = Ø1.125
- Keyway for a .25 IN square key

Place the centerline of the keyway in line with a radial line through the center of one tooth (one tooth profile needed to show alignment). Include the necessary spur gear data in a chart placed over the title block. Use the formulas given in this chapter to solve for unknown values.



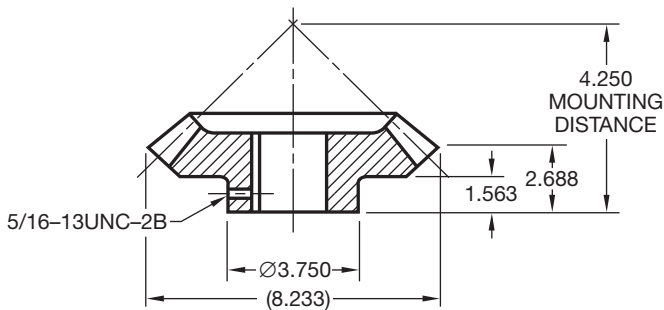
© Cengage Learning 2012

**PROBLEM 16.35** Use ASME standards to make a detail drawing of a rack that mates with the spur gear in Problem 16.34. Use the instructions provided with these problems. The overall length is 24 in. (in.).



**PROBLEM 16.36** Use ASME standards to make a detail drawing of a straight bevel gear given the following information and the illustration shown below (in.):

- Pitch diameter =  $\varnothing 8.000$  in.
- Pressure angle =  $20^\circ$
- 32 teeth
- Diametral pitch = 4
- Face width = 1.400
- Shaft diameter =  $\varnothing 1.125$  in.
- Use a .250 square key.
- Core distance = 4.401
- Circular thickness = 4.0939
- Pitch angle =  $65^\circ$
- Root angle =  $62.15^\circ$
- Addendum = .3022
- Whole depth = .5493
- Chordal addendum = .0496
- Chordal thickness = .7841



**PROBLEM 16.37** Prepare a detail drawing of the pinion and gear using the following gear data.

**DIMENSIONS FOR  $20^\circ$  STRAIGHT BEVEL GEAR  $90^\circ$  SHAFT ANGLE**

Feature	Pinion	Gear
Number of teeth	22	75
Diametral pitch	10	10
Face width	1.25	1.25
Pressure angle	$20^\circ$	$20^\circ$
Shaft angle	$90^\circ$	$90^\circ$
Working depth	0.200	0.200
Whole depth	0.221	0.221
Pitch diameter	2.200	7.500
Pitch angle	$16.348^\circ$	$73.652^\circ$
Cone distance	3.908	3.908
Circular pitch	0.314	0.314
Addendum	0.142	0.058
Dedendum	0.077	0.161
Clearance	0.021	0.021
Dedendum angle	$1.126^\circ$	$2.356^\circ$
Face angle of blank	$18.704^\circ$	$74.778^\circ$
Root angle	$15.222^\circ$	$71.296^\circ$
Outside diameter	2.473	7.533
Pitch apex to crown	3.710	1.044
Circular thickness	0.188	0.126
Backlash	0.002	0.002
Chordal thickness	0.186	0.125
Chordal addendum	0.146	0.058
Tooth angle	107.149 min	107.149 min
Limit point width	0.046	0.046
Tool advance	0.002	0.002

**Bearing Problems**

**Part 5: Problems 16.38 Through 16.41**

**PROBLEM 16.38** Use the charts shown in this chapter to establish the following medium-service bearing dimensions for an approximate  $\varnothing 1.25$  in. shaft. Use a word processor to type the problem number and the answer for each required item.

- Bearing catalog number \_\_\_\_\_
- Bore \_\_\_\_\_
- Outside diameter \_\_\_\_\_
- Width \_\_\_\_\_
- Fillet radius \_\_\_\_\_
- Shaft shoulder diameter \_\_\_\_\_
- Housing shoulder diameter \_\_\_\_\_
- Shaft diameter \_\_\_\_\_
- Housing diameter \_\_\_\_\_

**PROBLEM 16.39** Use the charts shown in this chapter to establish the following medium-service bearing dimensions for an approximate  $\text{Ø}03.5$  in. shaft. Use a word processor to type the problem number and the answer for each required item.

Bearing catalog number \_\_\_\_\_  
 Bore \_\_\_\_\_  
 Outside diameter \_\_\_\_\_  
 Width \_\_\_\_\_  
 Fillet radius \_\_\_\_\_  
 Shaft shoulder diameter \_\_\_\_\_  
 Housing shoulder diameter \_\_\_\_\_  
 Shaft diameter \_\_\_\_\_  
 Housing diameter \_\_\_\_\_

**PROBLEM 16.40** Use the charts shown in this chapter to establish the following medium-service bearing dimensions for an approximate  $\text{Ø}20$  mm shaft. Use a word processor to type the problem number and the answer for each required item.

Bearing catalog number \_\_\_\_\_  
 Bore \_\_\_\_\_  
 Outside diameter \_\_\_\_\_  
 Width \_\_\_\_\_  
 Fillet radius \_\_\_\_\_  
 Shaft shoulder diameter \_\_\_\_\_  
 Housing shoulder diameter \_\_\_\_\_  
 Shaft diameter \_\_\_\_\_  
 Housing diameter \_\_\_\_\_

**PROBLEM 16.41** Use the charts shown in this chapter to establish the following medium-service bearing dimensions for an approximate  $\text{Ø}60$  mm shaft. Use a word processor to type the problem number and the answer for each required item.

Bearing catalog number \_\_\_\_\_  
 Bore \_\_\_\_\_  
 Outside diameter \_\_\_\_\_  
 Width \_\_\_\_\_  
 Fillet radius \_\_\_\_\_  
 Shaft shoulder diameter \_\_\_\_\_  
 Housing shoulder diameter \_\_\_\_\_  
 Shaft diameter \_\_\_\_\_  
 Housing diameter \_\_\_\_\_

## Linkage Design Problems

### Part 6: Problems 16.42 and 16.43



To access the Chapter 16 problems, go to the Student CD, select **Chapter Tests and Problems** and **Chapter 16**, and then open the problem of your choice or as assigned by your instructor. Solve the problems using the instructions provided on the CD, unless otherwise specified by your instructor.

## Gear Design, Bearing Selection, Shaft Design Problem

### Part 7: Problem 16.44



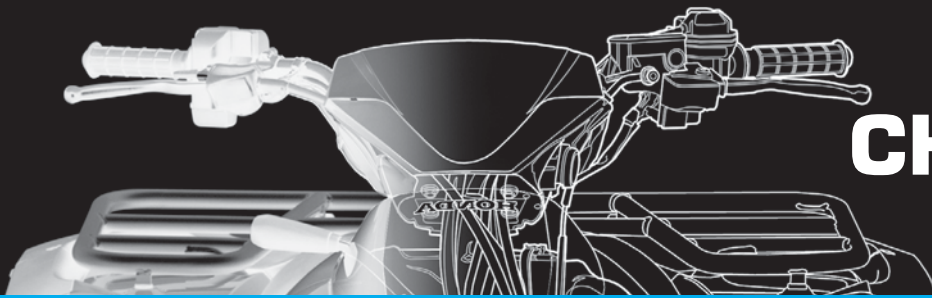
To access the Chapter 16 problems, go to the Student CD, select **Chapter Tests and Problems** and **Chapter 16**, and then open the problem of your choice or as assigned by your instructor. Solve the problems using the instructions provided on the CD, unless otherwise specified by your instructor.

## Math Problems

### Part 8: Problems 16.45 Through 16.50



To access the Chapter 16 problems, go to the Student CD, select **Chapter Tests and Problems** and **Chapter 16**, and then open the math problem of your choice or as assigned by your instructor. Solve the problems using the instructions provided on the CD, unless otherwise specified by your instructor.



# CHAPTER 17

## Belt and Chain Drives

### LEARNING OBJECTIVES

After completing this chapter, you will:

- Design chain drive systems from vendor specifications.
- Draw sprocket and chain designs from given engineering layouts.
- Design belt drive systems using vendor specifications.

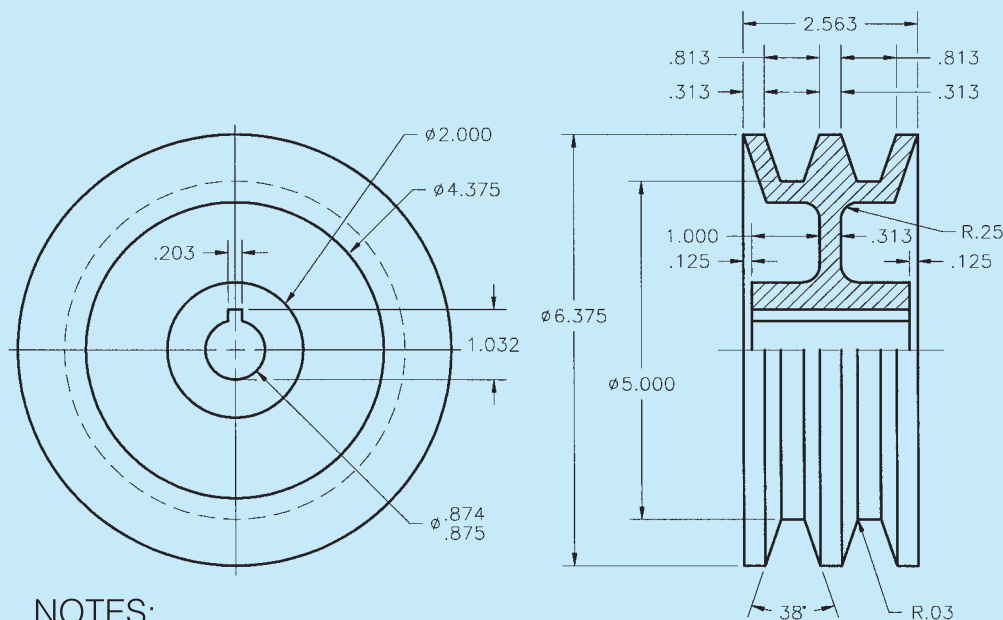
## THE ENGINEERING DESIGN APPLICATION

The problem is to design a two-belt **sheave** for class D conventional industrial belts. A sheave is a grooved wheel in a pulley block. The inside diameter (ID) should be 5.00 in. and the outside diameter (OD) 6.375 in. Provide 1.126 in. between belt centers. Keep the weight down as much as possible. Try for .375 in. web thickness. Design for a .875 in. shaft. Refer to the appendixes in this textbook or the *Machinery's Handbook* for the bore diameter and the recommended keyway for a parallel rectangular

key. Your research concludes that you need the following specifications:

- 38° V in sheave for belts.
- $\varnothing$ .874–.875 in. bore.
- .183 × 1.032 in. (measured from bottom of bore) keyway.
- You decide on a 2.00 in. hub for good material strength.

The problem solution is shown in Figure 17.1.



### NOTES:

1. DIMENSIONS AND TOLERANCES PER ASME Y14.5-2009.
2. REMOVE ALL BURRS AND SHARP EDGES.
3. ALL FILLETS AND ROUNDS R.06 UNLESS OTHERWISE SPECIFIED.

**FIGURE 17.1** Solution to engineering problem. Dimension values in this figure are in inches.

© Cengage Learning 2012

## INTRODUCTION

The function of **belt**, **chain**, and **gear drives** is to transmit power between rotating shafts. It is important to evaluate the advantages and disadvantages of each type of mechanism for the proper design and implementation of the final product. Gears were discussed in Chapter 16, because they fall into a class of linkage mechanisms where two or more elements of the linkage system are in direct contact with each other. Gears are also the most rugged and durable of the mechanisms, transmitting motion with little or no slippage. They can satisfy high power demands at efficiencies of up to 98%. The following gives advantages of gear, belt, and chain drives for your reference and future use.

## ADVANTAGES OF GEAR DRIVES

Gear drives are commonly used in some applications rather than belt or chain drives for the following reasons:

- More rugged and durable than most belt and chain drives.
- More efficient than belt or chain drives.
- More practical when space limitations require the shortest distance between centers.
- Have great maximum speed ratios.
- Work better when high horsepower and load capabilities are important.
- Preferable when nonparallel shafting is the design requirement.
- Used where timing and synchronization are required. Chain drives may work effectively in these applications, but belt drives are not recommended because of slippage.

## ADVANTAGES OF BELT DRIVES

Belt drives are often the choice of the designer when the following characteristics are important:

- Up to 95% efficient, especially at high speeds.
- Designed to slip when an overload occurs.
- Resist abrasion.
- Require no lubrication, because there is no metal-to-metal contact, except at shaft bearings.
- Normally smooth running and less noisy.
- Belt drives, especially those using flat belts, can be used more effectively when very long shaft center distances are required.
- Can operate effectively at high speed ranges.
- Flexible shaft center distances, where gear drives are restricted.
- Less expensive than gear or chain drives.
- Easy to assemble and install and have flexible tolerances.

- Absorb shock well.
- Easy and inexpensive to maintain.

## ADVANTAGES OF CHAIN DRIVES

Chain drive mechanisms have certain design advantages over both gear and belt drives:

- Flexible shaft center distances, where gear drives are restricted.
- Less expensive than gear drives, in most cases.
- Simpler installation and assembly tolerances than gear drives.
- Provide better shock-absorbing qualities than gears.
- Have no slippage as compared to belt drives, resulting in more efficient operation.
- Lower loads on shaft bearings because tension is not required as with belt drives.
- Easy to install.
- Not affected by sun, heat, or oil and do not deteriorate with age as do belts.
- More effective at lower speeds than belts.
- Require little adjustment, while belt drives require frequent adjustment.

## BELTS AND BELT DRIVES

**Belts** are used to transmit power from one shaft to another smoothly, quietly, and inexpensively. Belts are made of continuous construction from materials such as rubberized cord, leather strands, fabric, or, more commonly, reinforced nylon, rayon, steel, or glass fiber. Belts operate on shaft-mounted pulleys and sheaves. **Pulleys** are wheels constructed with a groove in the circumference to match the shape of the belt and transmit power to the belt. **Sheaves** are the same as pulleys except that sheaves are generally the drive and pulleys are the driven. Sheaves and pulleys both guide the belt in its operation, so the terms are normally used interchangeably.

## BELT TYPES

Different types of belts are designed for individual applications. The type of belt you are probably most familiar with is the V-belt, which is used for most automobile and household applications. Other belts, such as flat belts, are used for long center distances and high-speed applications. Positive drive belts fit notched pulleys and are designed for more positive power transmission than other belt designs.

## V-Belts

**V-belts** are the most commonly used belts. These belts have a wide range of applications and operating conditions. V-belts operate efficiently at speeds between 1500 and 6500 fpm (feet per minute) and a temperature range of  $-30^{\circ}$  to  $185^{\circ}$  F ( $-34^{\circ}$  to  $85^{\circ}$  C).

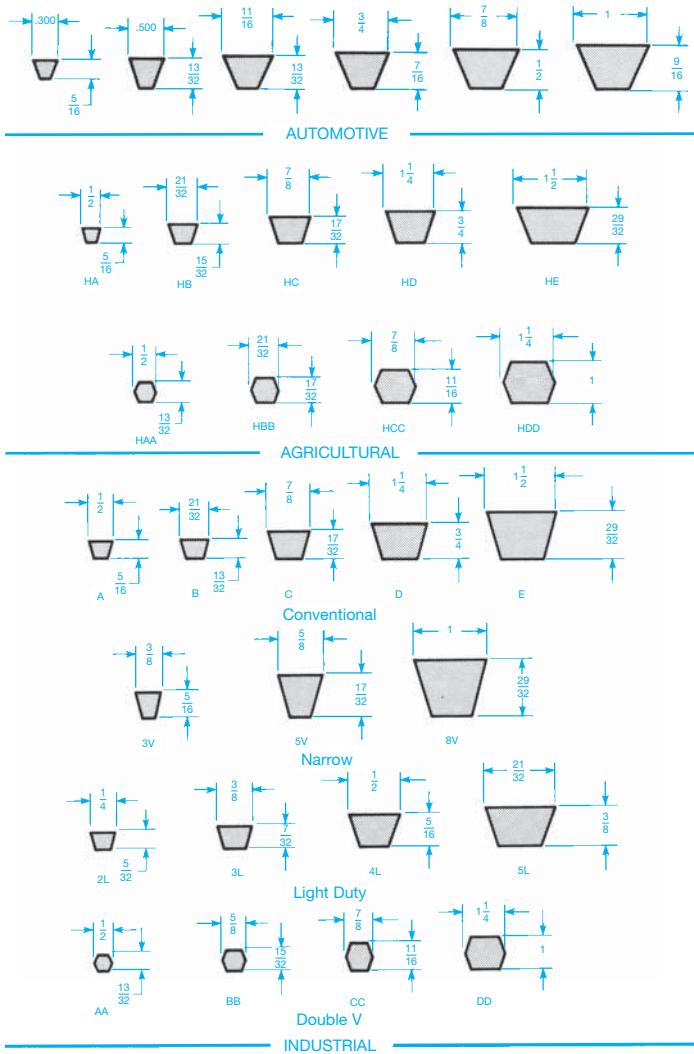


FIGURE 17.2 Standard V-belt types. © Cengage Learning 2012

**STANDARDS**

SAE V-belt manufacturers code the belts according to shape to help ensure interchangeability between suppliers. V-belts fall into three main categories: automotive, agricultural, and industrial. Automotive belts are manufactured in accordance with six Society of Automotive Engineers (SAE) approved sectional shapes. Agricultural V-belts are similar in shape to automotive V-belts. They are identified with a letter H. Industrial V-belts fall into the categories of conventional, narrow, light-duty, and double V cross section. A comparison of the standard V-belt cross section is shown in Figure 17.2.

The load-carrying capability of a V-belt is provided by reinforcing cords in the belt. The reinforcement is made of rayon, nylon, steel, or glass fibers. Figure 17.3 shows the construction of a V-belt with steel reinforcing cords. The reinforcing cords are usually embedded in a soft rubber material called a *cushion section*. The cushion section is surrounded by a hard rubber

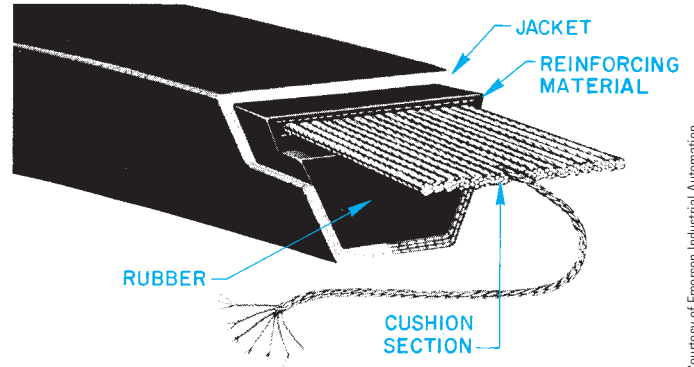


FIGURE 17.3 V-belt with steel reinforcing cables.

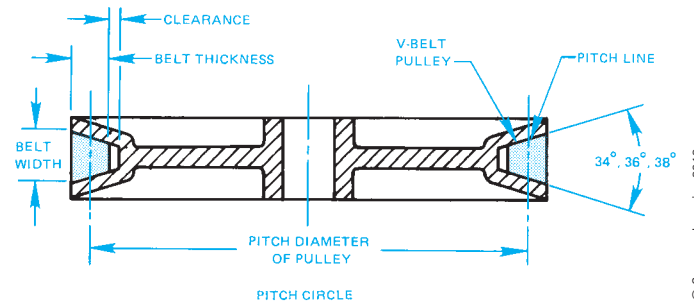


FIGURE 17.4 V-belt and pulley (sheave) cross section.

or other material and the internal structure is covered with an abrasion-resistant material.

The **pitch line** is the only portion of the belt that does not change length as the belt bends around the pulley. The pitch line is used to determine the pitch diameter of the pulley. The **pitch diameter** is the effective diameter of the pulley, which is used to establish the speed ratio. Most pulleys are made of cast iron, steel, or aluminum. The construction and terminology of a pulley and mating belt are shown in Figure 17.4.

**Flat Belts**

**Flat belts** are typically used where high-speed applications are more important than power transmission and when long center distances are necessary. Flat belts are less efficient at moderate speeds, because they tend to slip under load. Flat belts are also used where drives with nonparallel shafts are required, because the belt can be twisted to accommodate the relationship of the shafts.

**Positive Drive Belts**

**Positive drive belts** have a notched underside that contacts a pulley with the same design on the circumference. These belts have some of the same advantages as chain and gear drives because of their positive contact between the belt and the pulley. These belts are more suitable for operations requiring high efficiency, timing, or constant velocity. Positive drive belts can also be used to decrease the pulley size and give the same operating performance of a larger sized V-belt pulley. A sample positive drive belt is shown in Figure 17.5.



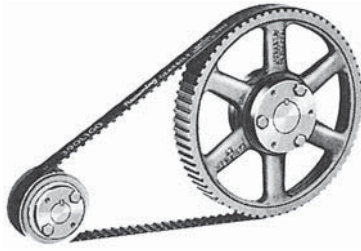


FIGURE 17.5 Positive drive belt. Courtesy of Emerson Industrial Automation

### TYPICAL BELT DRIVE DESIGN

Belt drives are designed with or without an idler. The **idler** is often used to help maintain constant tension on the belt (see Figure 17.6).

When belts are in operation, they stretch. Machines that are operated by belt drives must have an idler, an adjustable motor base, or both to provide for belt adjustment. Maintenance of the tension between the shafts is important in controlling the efficiency of the belt drive. Figure 17.7 shows an assembly drawing of an adjustable motor base. There are many different types of adjustable motor bases, including the sliding and tilting types.

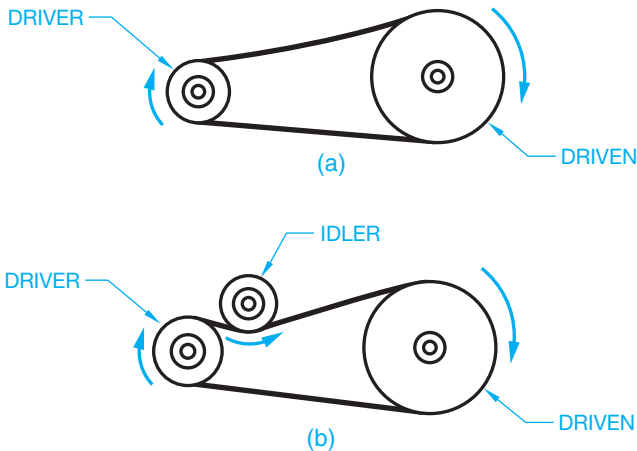


FIGURE 17.6 (a) V-belt arrangement. (b) Belt drive with an idler.

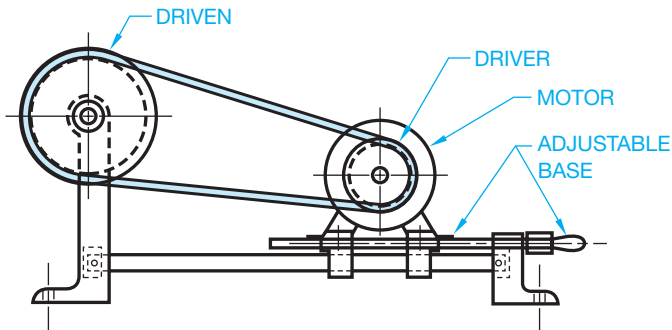


FIGURE 17.7 V-belt drive arrangement with adjustable motor base.

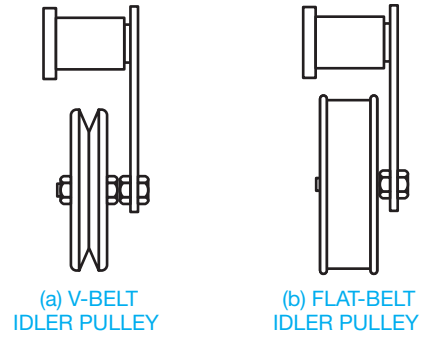


FIGURE 17.8 Idler pulleys. (a) V-belt idler pulley. (b) Flat-belt idler pulley.

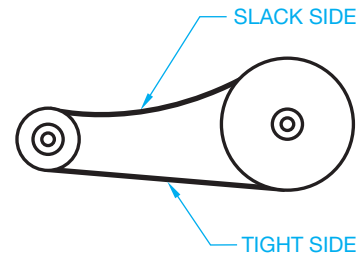


FIGURE 17.9 Belt drive slack side and tight side.

In some cases, adjustable motor bases are not practical. When this occurs, idler pulleys are used to keep belts tight. A V-belt and flat-belt idler are displayed in Figure 17.8. When idler pulleys are used, their size and location in relation to the belt drive are important. When referring to the placement of the idler pulley, the terms **slack side** and **tight side** are used. When the belt is in operation, the slack side is the belt on the top of the drive and the tight side is normally on the bottom of the drive when the driver and driven shafts are in horizontal alignment as shown in Figure 17.9. There are several typical design positions for the location of the idler pulley in relation to the driver pulley. An inside idler pulley is placed near the driver on the slack side of the belt. It should be the same diameter or larger than the driver. An inside idler pulley may also be placed on the tight side near the driven pulley. An outside idler pulley is placed near the driver on the outside of the belt on the slack side. The best design for this application is to have the idler pulley slightly larger in diameter than the driver pulley. When an outside idler pulley is placed on the tight side, it is normally placed near the driven pulley (see Figure 17.10)

### BELT DRIVE SELECTION

Belts are selected for a specific application based on the function of the machinery. The factors influencing the selection and design of belt drives include:

- Horsepower of driving shaft.
- Type of machine.
- Speed of driving shaft.
- Center distance between shafts.
- Service conditions.
- Belt length.
- Number of belts required.

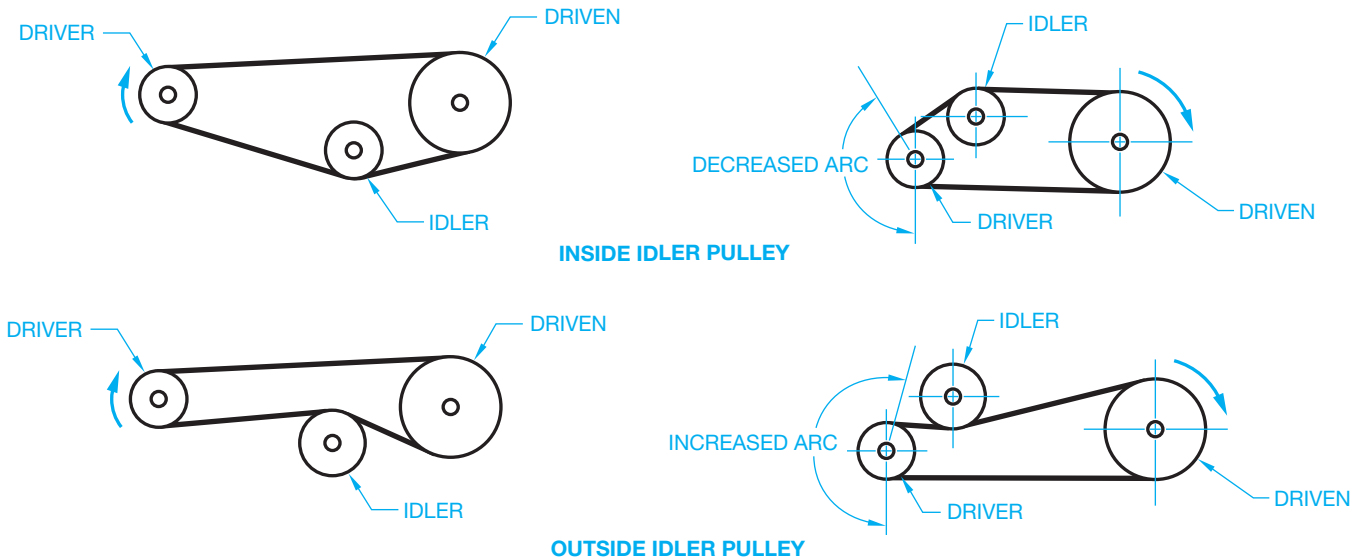


FIGURE 17.10 Idler pulley arrangements.

© Cengage Learning 2012

### Designing V-Belt Drives

Belt manufacturers provide formulas and catalogs of the design and selection of belt drives based on the criteria described previously. The following discussion is based on engineering data provided in the *Browning Power Transmission* catalog, produced by the Browning Manufacturing Division of Emerson Power Transmission Company. Other manufacturer catalogues and specifications are available. A sample problem is used in the following in order to select a drive using standard drive selection tables. The content and standard drive selection tables are provided courtesy of Browning Manufacturing Division of Emerson Power Transmission Company.

A drive is required for an 18 horsepower (HP) motor driving a fan 16 hours per day. The motor speed is 3600 revolutions per minute (rpm), and the shaft size is 1.625 in. The fan speed is approximately 2250 rpm, and the fan shaft is 1.438 in. The center distance is 38 in. minimum and 41 in. maximum.

**STEP 1** Determine the design horsepower. The design HP of a machine takes into account the type of service and the efficiency of a particular machine. Design horsepower is calculated using the formula:

$$\text{Design HP} = \text{Rated HP} \times \text{Service Factor}$$

The rated horsepower is the horsepower specified on the driver motor. For example, the label on the motor may read 2 HP. The service factor is determined by the type of machinery, the number of hours of daily operation, and the type of driven unit. Service factors can be selected from the chart shown in Figure 17.11. Based on the example problem, a fan operating 16 hours per day has a service factor of 1.3. Calculate the design HP:

$$18 \text{ HP} \times 1.3 = 26 \text{ Design HP}$$

TYPES OF DRIVEN MACHINES	TYPES OF DRIVING UNITS		
	AC Motors; Normal Torque, Squirrel Cage, Synchronous and Split Phase, DC Motors; Shunt Wound. Multiple Cylinder Internal Combustion Engines.		
	Intermittent Service (3-5 Hours Daily or Seasonal)	Normal Service (8-10 Hours Daily)	Continuous Service (16-24 Hours Daily)
Agitators for Liquids Blowers and Exhausters Centrifugal Pumps and Compressors Fans up to 10 HP Light Duty Conveyors	1.0	1.1	1.2
Belt Conveyors For Sand, Grain, etc. Dough Mixers Fans Over 10 HP Generators Line Shafts Laundry Machinery Machine Tools Punches-Presses-Shears Printing Machinery Positive Displacement Rotary Pumps Revolving and Vibrating Screens Speed Reducers, All Types	1.1	1.2	1.3
Brick Machinery Bucket Elevators Exciters Piston Compressors Conveyors (Drag-Pan-Screw) Hammer Mills Paper Mill Beaters Piston Pumps Positive Displacement Blowers Pulverizers Saw Mill and Woodworking Machinery Textile Machinery	1.2	1.3	1.4
Crushers (Gyratory-Jaw-Roll) Mills (Ball-Rod-Tube) Hoists Rubber Calendars-Extruders-Mills	.3	1.4	1.5

A minimum Service Factor of 2.0 is suggested for equipment subject to choking.\*

**\* CAUTION—Drives requiring high Overload Services Factors, such as crushing machinery, certain reciprocating compressors, etc. subjected to heavy shock load without suitable fly wheels, may need heavy duty web type sheaves rather than standard arm type. For any such application, consult the Browning Engineers.**

FIGURE 17.11 Step 1: Service factors for belt drives. Courtesy of Emerson Industrial Automation

**STEP 2** Determine the driven speed. To establish the required driven speed, refer to Figure 17.12. Find the “Nominal Driven Speeds and Horsepower per Belt” column. Under the column labeled “3500 RPM Motor,” find the “Nominal Driven RPM” column. Select the rpm equal to or less than the given fan speed of 2250 rpm. Fifteen combinations that provide 2244 rpm for the driven pulley are highlighted in Figure 17.12.

**STEP 3** Determine the available selections. Refer again to Figure 17.12 and look under the “HP per Belt” column to determine which sheave combination results in the smallest sheave diameters, the least number of belts, and the lightest belt selection for the sample problem. To begin this process, assume your selection is found in the “Gripnotch” column under HP per belt. If you use a “Super” belt, another selection would be made. Read down the “Gripnotch” column until you find the largest HP per belt (12.94) without exceeding the design HP(26) when multiplied by one, two, or three belts. Your goal is to use the least number of belts. Therefore, the best solution in this case is 2 belts × 12.94 × 25.88. 25.88 is less than the 26-design HP. These items must be equal to or less than the given

data. Of the 15 selections from Step 2, the proposed selections are highlighted in Figure 17.12. They are:

- Pitch Diameter (PD) Driver = 5.4 in.
- PD Driven = 8.4 in.
- Belt Section = B
- Number of Belts = 1 minimum and 3 maximum (exact number to be determined later)
- HP per Belt = 12.94

**STEP 4** Determine the belt part number for the approximate center distance and the F factor for the belt. The selected center distance, as stated in the problem, must be between 38 and 41 in. The F factor is a correction factor for the loss of arc of contact. The standard arc contact for a belt to sheave is 180°. When the belt does not contact 180°, there is loss or gain of arc contact. When there is loss or gain of arc contact, a correction factor must be used to establish the corrected horsepower and number of belts required. Look at Figure 17.13, which is an extension of the chart in Figure 17.12. Find the center distance (CD) in the horizontal column that is closest to the required center distance. If you cannot find an acceptable CD between the given requirements, then find a pair of CDs

3500 and 1750 RPM Motors

Ratio	Sheave Combination		Belt Section	No. of Grooves		Nominal Driven Speeds and Horsepower per Belt						Nominal Center Distance (C.D.) and Arc-Length Factor (F) Using Browning Belts								
	Driver P.D.	Driven P.D.		Min.	Max.	3500 RPM Motor			1750 RPM Motor			Belt No.	C.D.	F.	Belt No.	C.D.	F.	Belt No.	C.D.	F.
						Nominal Driven RPM	Super	Gripnotch	Nominal Driven RPM	Super	Gripnotch									
1.54	10.4	16.0	B	1	3	—	—	—	1136	14.97	17.10	B67	13.4	0.87	B74	16.9	0.90	B81	20.5	0.94
1.54	13.0	20.0	C	1	12	—	—	—	1136	27.81	33.05	C85	17.7	0.85	C100	25.3	0.89	C112	31.3	0.91
1.55	3.8	5.9	B	1	3	2258	4.33	8.03	1129	3.32	5.33	B28	7.2	0.73	B45	15.7	0.84	B56	21.3	0.89
1.55	4.0	6.2	A	1	6	2258	5.19	6.35	1129	3.31	4.17	A26	5.5	0.76	A36	10.6	0.84	A46	15.6	0.89
1.55	4.0	6.2	B	1	6	2258	5.00	8.71	1129	3.75	5.76	B28	6.8	0.71	B45	15.3	0.84	B56	20.9	0.87
1.55	9.6	14.9	5V	2	10	—	—	—	1129	27.32	32.36	5V670	14.0	0.85	5V800	20.6	0.89	5V950	28.1	0.93
1.56	3.2	5.0	A	1	6	2244	3.62	4.35	1122	2.32	2.92	A24	6.1	0.78	A35	11.7	0.84	A45	16.7	0.88
1.56	3.2	5.0	B	1	2	2244	2.18	5.87	1122	1.99	4.00	B28	8.4	0.73	B45	16.9	0.84	B56	22.4	0.89
1.56	3.6	5.6	A	1	6	2244	4.43	5.38	1122	2.82	3.56	A24	5.3	0.76	A35	10.9	0.84	A45	15.9	0.88
1.56	3.6	5.6	B	1	6	2244	3.63	7.33	1122	2.88	4.89	B28	7.6	0.73	B45	16.1	0.84	B56	21.6	0.89
1.56	3.9	6.1	B	1	3	2244	4.67	8.38	1122	3.54	5.55	B28	7.0	0.71	B45	15.5	0.84	B56	21.0	0.87
1.56	4.1	6.4	B	1	3	2244	5.33	9.05	1122	3.97	5.97	B28	6.6	0.71	B45	15.1	0.84	B56	20.6	0.87
1.56	4.1	6.4	3V	1	4	2244	7.72	8.76	1122	4.47	4.90	3V280	5.6	0.79	3V335	8.4	0.84	3V400	11.7	0.89
1.56	4.5	7.0	A	1	3	2244	6.07	7.50	1122	3.90	4.92	A29	6.0	0.78	A39	11.0	0.84	A49	16.1	0.90
1.56	4.5	7.0	5V	2	5	2244	—	17.45	1122	—	10.28	5V500	15.9	0.82	5V630	22.4	0.86	5V800	30.9	0.92
1.56	4.8	7.5	A	1	1	2244	6.56	8.15	1122	4.26	5.36	A31	6.3	0.79	A40	10.9	0.85	A49	15.4	0.90
1.56	5.4	8.4	B	1	3	2244	9.06	12.94	1122	6.66	8.65	B34	6.9	0.74	B47	13.5	0.84	B58	19.0	0.88
1.56	5.4	8.4	5V	2	5	2244	—	24.53	1122	—	14.42	5V500	14.1	0.82	5V630	20.6	0.86	5V800	29.1	0.90
1.56	5.5	8.6	A	1	3	2244	7.57	9.53	1122	5.05	6.36	A36	7.4	0.81	A45	12.0	0.87	A54	16.5	0.92
1.56	6.4	10.0	A	1	3	2244	8.58	11.03	1122	6.02	7.58	A42	8.6	0.84	A50	12.6	0.89	A58	16.7	0.93
1.57	2.8	4.4	A	1	2	2229	2.76	3.26	1115	1.80	2.28	A24	6.9	0.78	A35	12.5	0.84	A45	17.5	0.90
1.57	3.0	4.7	A	1	3	2229	3.19	3.81	1115	2.06	2.60	A24	6.5	0.78	A35	12.1	0.84	A45	17.1	0.90
1.57	3.5	5.5	A	1	3	2229	4.23	5.13	1115	2.69	3.40	A24	5.5	0.76	A35	11.0	0.84	A45	16.0	0.88
1.57	3.7	5.8	A	1	3	2229	4.62	5.63	1115	2.94	3.71	A24	5.1	0.75	A35	10.6	0.84	A45	15.7	0.88
1.57	4.2	6.6	A	1	6	2229	5.56	6.83	1115	3.55	4.48	A27	5.5	0.76	A37	10.6	0.84	A47	15.6	0.89
1.58	4.8	7.6	A	1	6	2215	6.56	8.16	1108	4.26	5.36	A31	6.3	0.79	A40	10.8	0.85	A49	15.3	0.90
1.58	5.0	7.9	B	1	1	2215	8.04	11.85	1108	5.86	7.86	B32	6.6	0.73	B46	13.7	0.84	B57	19.2	0.87
1.58	5.2	8.2	A	1	10	2215	7.16	8.97	1108	4.71	5.94	A34	7.0	0.80	A43	11.5	0.86	A52	16.1	0.92
1.58	5.7	9.0	A	1	3	2215	7.83	9.90	1108	5.27	6.64	A37	7.4	0.82	A46	12.0	0.88	A55	16.5	0.93
1.58	6.0	9.5	A	1	1	2215	8.18	10.41	1108	5.60	7.05	A39	7.8	0.82	A47	11.8	0.88	A55	15.9	0.92
1.58	6.6	10.4	B	1	3	2215	11.51	15.74	1108	8.97	10.95	B43	8.8	0.80	B53	13.9	0.86	B63	19.0	0.89
1.58	6.7	10.6	A	1	1	2215	8.85	11.46	1108	6.33	7.98	A44	8.9	0.85	A52	12.9	0.89	A60	16.9	0.94
1.58	6.9	10.9	B	1	1	2215	11.95	16.30	1108	9.52	11.50	B45	9.2	0.81	B55	14.3	0.86	B65	19.3	0.90
1.58	7.2	11.4	C	2	6	—	—	—	1108	12.92	19.41	C51	12.2	0.76	C75	24.2	0.84	C96	34.8	0.89
1.58	7.4	11.7	5V	2	8	—	—	—	1108	18.97	23.39	5V500	9.8	0.79	5V630	16.4	0.85	5V800	24.9	0.90

FIGURE 17.12 Steps 2 and 3: Motor speed and drive selection table. Courtesy of Emerson Industrial Automation

3500 and 1750 RPM Motors

Nominal Center Distance (C.D.) and Arc-Length Factor (F) Using Browning Belts																		Sheave Combination		Ratio
Belt No.	C.D.	F.	Belt No.	C.D.	F.	Belt No.	C.D.	F.	Belt No.	C.D.	F.	Belt No.	C.D.	F.	Belt No.	C.D.	F.	Driver P.D.	Driven P.D.	
5V1120	36.7	0.95	5V1320	46.7	0.98	5V1600	60.7	1.03	5V1900	75.7	1.06	5V2240	92.7	1.08	5V3550	158.2	1.17	9.6	14.9	1.55
A55	21.7	0.95	A65	26.7	0.98	A75	31.7	1.01	A85	36.7	1.05	A95	41.7	1.06	A180	84.2	1.19	3.2	5.0	1.56
B67	27.9	0.93	B78	33.4	0.97	B88	38.4	1.00	B99	43.9	1.02	B136	62.5	1.09	B360	173.7	1.31	3.2	5.0	1.56
A55	20.9	0.95	A65	25.9	0.98	A75	30.9	1.01	A85	35.9	1.04	A95	40.9	1.06	A180	83.4	1.19	3.6	5.6	1.56
B67	27.2	0.93	B78	32.7	0.97	B88	37.7	0.99	B99	43.2	1.02	B136	61.7	1.09	B360	172.9	1.31	3.6	5.6	1.56
B67	26.5	0.93	B78	32.0	0.97	B88	37.0	0.99	B99	42.5	1.01	B136	61.0	1.09	B360	172.3	1.31	3.9	6.1	1.56
B67	26.1	0.93	B78	31.6	0.97	B88	36.6	0.99	B99	42.1	1.01	B136	60.6	1.09	B360	171.9	1.31	4.1	6.4	1.56
3V475	15.5	0.92	3V560	19.7	0.95	3V670	25.2	1.00	3V800	31.7	1.03	3V950	39.2	1.07	3V1400	61.7	1.15	4.1	6.4	1.56
A59	21.1	0.94	A69	26.1	0.99	A79	31.1	1.02	A89	36.1	1.04	A100	41.6	1.07	A180	81.6	1.19	4.5	7.0	1.56
5V1000	40.9	0.95	5V1250	53.5	1.00	5V1600	71.0	1.04	5V2000	91.0	1.08	5V2500	116.0	1.11	5V3550	168.5	1.17	4.5	7.0	1.56
A58	19.9	0.94	A67	24.5	0.97	A76	29.0	1.01	A85	33.5	1.04	A94	38.0	1.05	A180	81.0	1.19	4.8	7.5	1.56
B69	24.5	0.92	B80	30.0	0.97	B90	35.0	0.99	B103	41.5	1.02	B144	62.0	1.11	B360	169.3	1.31	5.4	8.4	1.56
5V1000	39.1	0.95	5V1250	51.6	0.99	5V1600	69.1	1.04	5V2000	89.2	1.08	5V2500	114.2	1.11	5V3550	166.7	1.17	5.4	8.4	1.56
A63	21.0	0.96	A72	25.5	0.98	A81	30.0	1.01	A90	34.5	1.05	A100	39.5	1.07	A180	79.6	1.19	5.5	8.6	1.56
A66	20.7	0.97	A74	24.7	0.99	A82	28.7	1.01	A90	32.7	1.03	A98	36.7	1.07	A180	77.7	1.19	6.4	10.0	1.56
A55	22.5	0.95	A65	27.5	0.98	A75	32.5	1.02	A85	37.5	1.05	A95	42.5	1.06	A180	85.0	1.19	2.8	4.4	1.57
A55	22.1	0.95	A65	27.1	0.98	A75	32.1	1.01	A85	37.1	1.05	A95	42.1	1.06	A180	84.6	1.19	3.0	4.7	1.57
A55	21.1	0.95	A65	26.1	0.98	A75	31.1	1.01	A85	36.1	1.04	A95	41.1	1.06	A180	83.6	1.19	3.5	5.5	1.57
A55	20.7	0.93	A65	25.7	0.98	A75	30.7	1.01	A85	35.7	1.04	A95	40.7	1.05	A180	83.2	1.19	3.7	5.8	1.57
A57	20.6	0.94	A67	25.6	0.99	A77	30.6	1.01	A87	36.6	1.04	A97	40.6	1.07	A180	82.2	1.19	4.2	6.6	1.57
A58	19.9	0.94	A67	24.4	0.97	A76	28.9	1.01	A85	33.4	1.04	A94	37.9	1.05	A180	80.9	1.19	4.8	7.6	1.58
B68	24.7	0.92	B79	30.2	0.97	B89	35.2	0.99	B100	40.7	1.02	B140	60.7	1.10	B360	170.0	1.31	5.0	7.9	1.58
A61	20.6	0.95	A70	25.1	0.98	A79	29.6	1.00	A88	34.1	1.04	A97	38.6	1.07	A180	80.1	1.19	5.2	8.2	1.58
A64	21.0	0.96	A73	25.5	0.98	A82	30.1	1.01	A91	34.6	1.05	A103	40.6	1.07	A180	79.1	1.19	5.7	9.0	1.58
A63	19.9	0.96	A71	23.9	0.98	A79	27.9	1.00	A87	31.9	1.02	A95	35.9	1.05	A180	78.5	1.19	6.0	9.5	1.58
B73	24.0	0.93	B82	29.0	0.94	B92	33.5	0.97	B105	40.0	1.03	B144	59.5	1.10	B360	166.8	1.31	6.6	10.4	1.58
A68	21.0	0.97	A76	25.0	0.99	A84	29.0	1.01	A92	33.0	1.03	A103	38.5	1.05	A180	77.0	1.18	6.7	10.6	1.58
B75	24.3	0.94	B84	28.8	0.96	B94	33.9	0.98	B112	42.9	1.04	B154	63.9	1.11	B360	166.2	1.31	6.9	10.9	1.58
C112	42.8	0.94	C136	54.8	0.98	C162	67.8	1.02	C210	91.8	1.08	C270	120.8	1.14	C420	195.8	1.24	7.2	11.4	1.58
5V1000	34.9	0.93	5V1250	47.4	0.99	5V1600	65.0	1.03	5V2000	85.0	1.07	5V2500	110.0	1.11	5V3550	162.5	1.17	7.4	11.7	1.58

FIGURE 17.13 Step 4: Nominal center distances, number of belts, arc length factor chart. Courtesy of Emerson Industrial Automation

as highlighted in Figure 17.13. In this case, you have located:

- Belt B90 with a CD of 35.0 in. and F of 0.99
- Belt B103 with a CD of 41.5 and F of 1.02

To establish the exact belt for this application, you must interpolate. Interpolate means to make an approximation between existing known values. Interpolate to find the correct belt for the application using this method:

For every inch of belt length difference between belts, there is about 1/2 in. of center distance change. The belt numbers represent a relationship. For example, the B90 belt is 13 in. shorter than the B103 belt (B103 - B90 = 13). For this example, if you subtract 3 IN from a B103 belt, you get a B100 belt. If there is 1/2 in. of CD change for every inch of belt length, then 3 in. of length change equals 1.5 in. of CD change. Therefore, the B100 belt has a CD of 40 in.

Now determine the F factor of the B100 belt by comparing the values of the known belts:

- B90 in. CD = 35 F = .99
- B100 in. CD = 40 F = ?
- B103 CD = 41.5 in. F = 1.02

Establish the difference in F factor between the B90 and B103 belts.

$$1.02 - .99 = .03 \text{ (difference in F factor)}$$

Establish the difference in CD between the B90 and B103 belts:

$$41.5 - 35 = 6.5 \text{ in. (difference in CD)}$$

Now divide the difference in F factor by the difference in CD to determine the F factor per inch of CD:

$$.03 \text{ divided by } 6.5 = .0046 \text{ (F factor per inch of CD).}$$

The B100 belt has a 40 in. CD, which is 1.5 in. less than the B103 belt; so, the B100 belt has an F factor of  $1.5 \times .0046$  less than the B103 belt:

$$1.5 \times .0046 = .0069$$

$$F \text{ 1.02 (B103 belt)} - .0069 = 1.01 \text{ (rounded from 1.013)}$$

F factor for the B100 belt.

Therefore, the B100 belt has an F factor of 1.01.

**STEP 5** Determine the corrected horsepower and number of belts for the drive. The corrected horsepower is an adjustment of the design horsepower in relation to the F factor. It is calculated with this formula:

$$F \text{ Factor} \times \text{HP per Belt} = \text{Corrected Horsepower}$$

The corrected horsepower for the sample problem is:

$$1.01 \text{ (F)} \times 12.94 \text{ (HP per belt)} = 13.06 \text{ Corrected HP per Belt}$$

Now determine the number of belts required for the drive using this formula:

Design HP/Corrected HP Number of Belts

If the number calculated in this formula is one or less, then one belt is required; or two belts for two or less; three belts for three or less; and so on. The number of belts for the sample problem is:

$$\frac{26 \text{ (Design HP)}}{13.06 \text{ (Corrected HP)}} 1.99 \\ = 2 \text{ Belts Required}$$

In conclusion, the design solution to the sample problem is as follows:

26 Design HP  
 12.94 Design HP per Belt  
 13.06 Corrected HP per Belt  
 B100 Belt Number  
 40 in. Center Distance  
 2 Belts Required  
 Ø5.4 in. Driver Pitch Diameter (PD)  
 Ø8.4 in. Driven PD  
 B Belt Section

## Determine the Belt Drive Ratio

The **belt drive ratio** is the relationship between the drive and driven pulleys. The ratio can be determined by dividing the rpm of the driver by the rpm of the driven pulley. If you use the sample problem presented earlier, for example, the motor rpm from Figure 17.12 is 3500 rpm, and the nominal driven rpm from the same chart is 2244 rpm. Therefore, the ratio =  $3500 \text{ rpm}/2244 \text{ rpm} = 1.5597 = 1.56$ . Now, refer back to Figure 17.12 and notice the 1.56 highlighted in the ratio column at the far left. This 1.56 ratio coincides with the other items selected for the application.

## Determine the Belt Velocity

**Belt velocity** is the speed a belt travels in feet per minute (fpm) for a given application. In some cases, the belt velocity can be important. In many applications, though, it is not a factor. Belt velocity becomes important at very high speeds. For example, cast iron sheaves should not travel at speeds greater than 6500 fpm. Another factor that influences design at high speeds is vibration, which can require balancing of the sheaves. Belt velocity is calculated using this formula:

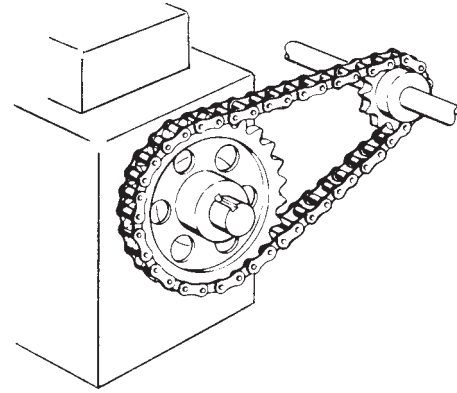
$$\text{Belt Velocity fpm} = \text{Pitch Diameter (PD)} \\ \text{Sheave} \times 0.2618 \times \text{Sheave Speed rpm}$$

(0.2618 is a constant to be used for all applications)

The belt velocity for the driver sheave of the sample problem is  $\text{Ø}5.4 \text{ (PD Sheave)} \times 0.2618 \times 3500 \text{ rpm} = 4948 \text{ fpm}$

## CHAIN DRIVES

Chain drives, like gear and belt drives, are used to transmit power from one shaft to another. As discussed earlier, chain drives have certain advantages over gear and belt drives. In



Courtesy/Morse Industrial

FIGURE 17.14 Chain drive sprockets and chain.

general, chain drives are less efficient and durable than gear drives, but they offer greater power capacity, more position power transmission, durability, and longer service life than belts, especially at high temperatures.

In chain drive applications, toothed wheels called **sprockets** mate with a chain to transmit power from one shaft to another (see Figure 17.14). A **sprocket** is a wheel with teeth on its periphery to engage a chain.

## CHAIN DRIVE SPROCKETS

Sprockets are designed for various applications. Depending on the shaft mounting requirements, sprockets are available with a hub on one or both sides or without hubs. Sprockets are designed with a solid web in most applications, although weight is reduced by designing recessed webs or spokes.

Sprockets are machined from cast iron, steel, aluminum alloy, powdered metal, or plastic. Split sprockets are used when mounting between bearings requires easy installation. Some applications have sprockets mounted to a removable steel or cast iron hub when frequent replacement is required.

## CHAIN CLASSIFICATION AND TYPES

Chains are classified in relation to the accuracy of construction between the sprocket and the chain links. There are three broad categories: precision, nonprecision, and light-duty chains.

## PRECISION CHAINS

**Precision chains** are designed for smooth, free-running operation at high speed and high power. Common precision chains include the roller, offset sidebar, silent inverted tooth, and double pitch chains.

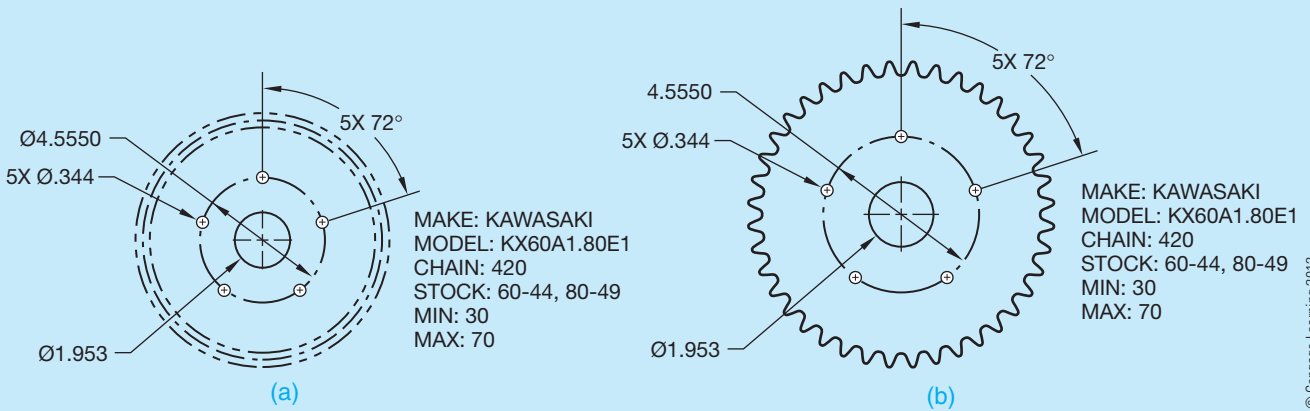
## Roller Chain

**Roller chain** is the most commonly used power transmission chain. Roller chain is rated up to 630 HP for single-chain drives and is referred to as single-strand chain. Roller chains can be added in multiple units, known as multiple-strand chains, to

## SPROCKETS

The same simplified representation used in gear CADD drawings can also be used for sprocket CADD drawings,

or custom software is available to automatically generate detailed drawings from given data (see Figure 17.15).



**FIGURE 17.15** Sprocket drawing: (a) Simplified representation. (b) Detailed representation. Dimension values in this figure are in inches.

© Cengage Learning 2012

substantially increase the horsepower under which they can operate. Roller chains provide efficient, quiet operation and should be lubricated for the best service life. Figure 17.16 shows the parts of a typical roller chain.

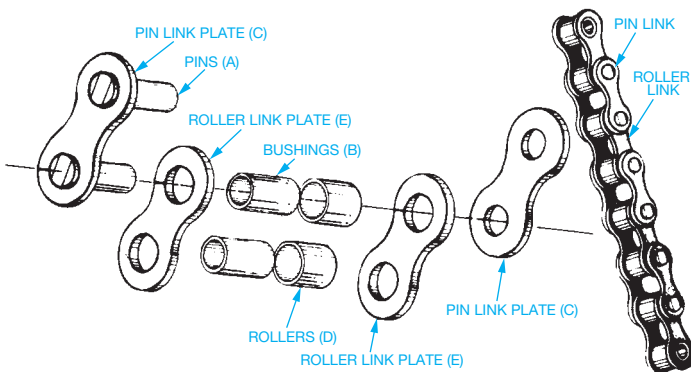
The **chain pitch** is important when designing a chain drive. The chain pitch is the distance from the center of one pin to the center of the other pin in one link. Figure 17.17 shows a single-strand chain with the pitch dimensioned and a multiple-strand chain. Roller chains are available with pitch lengths ranging from 1/4 to 3 in.

### Double Pitch Roller Chain

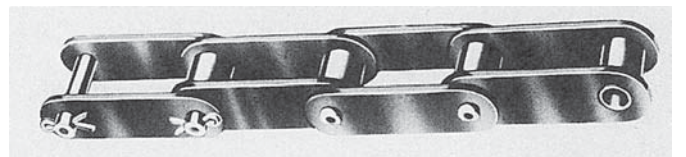
**Double pitch roller chain** is designed mostly for situations with long center distances such as conveyors. While the efficiency of the double pitch chain is as good as the roller chain, it is intended for lighter-duty operation than regular pitch roller chain (see Figure 17.18).



**FIGURE 17.17** Single-strand and multiple-strand roller chain. Courtesy Morse Industrial

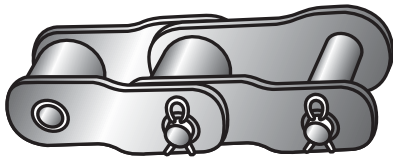


**FIGURE 17.16** Roller chain assembly. Courtesy Rainbow Industrial Products Corp.



**FIGURE 17.18** Double pitch roller chain.

Courtesy Morse Industrial



© Cengage Learning 2012

FIGURE 17.19 Offset sidebar roller chain.

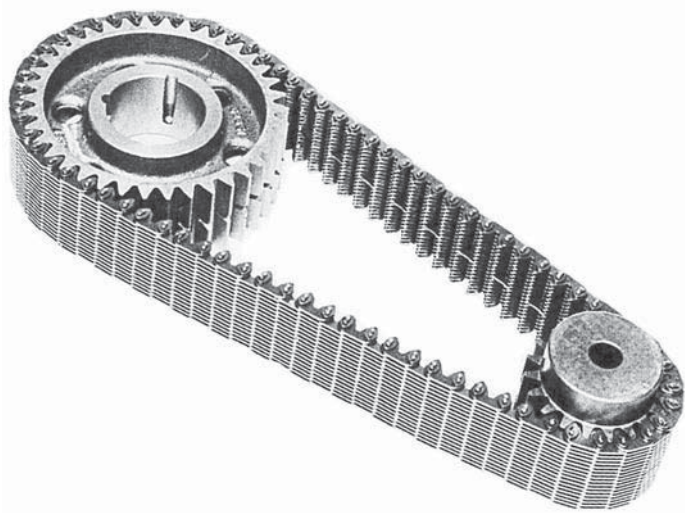


FIGURE 17.20 Inverted tooth silent chain. Courtesy Morse Industrial

## Offset Sidebar Roller Chain

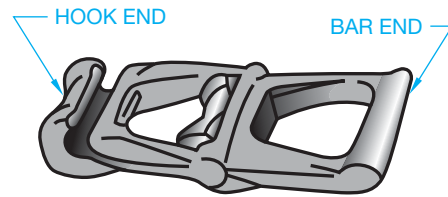
The **offset sidebar**, shown in Figure 17.19, is the least expensive precision chain. It is designed to carry heavier loads than non-precision chains. Offset sidebar chains are designed to handle loads up to 425 HP and speeds up to 36 feet per second. One of the advantages of the offset sidebar chain over the other chain types is its open construction, which allows it to withstand dirt and contaminants that might cause other precision chains to bind and wear out rapidly. For this reason and because they are rugged and durable, offset sidebar chains are often used to drive construction machinery.

## Inverted Tooth Silent Chain

The most expensive precision chain to manufacture is the **inverted tooth silent chain** shown in Figure 17.20. This chain is used where high speed and smooth, quiet operation are required in rigorous applications. Lubrication is required to keep these chains running trouble free. Applications include machine tools, pumps, and power drive units.

## NONPRECISION CHAINS

**Nonprecision chains** do not have as high a degree of precision between the sprocket and chain links. These lower cost chains are generally used for low-speed applications on machinery rated below 50 HP. Nonprecision chains include detachable, pintle, and welded chains.



© Cengage Learning 2012

FIGURE 17.21 Detachable chains.

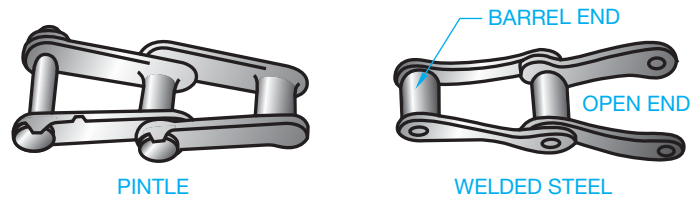


FIGURE 17.22 Pintle and welded steel chains. © Cengage Learning 2012

## Detachable Chain

The **detachable chain** shown in Figure 17.21 is the lightest, simplest, and least expensive of all chains. The detachable chain is capable of transmitting power up to 25 HP at low speeds. One common application is farm machinery requiring speeds of up to 350 fpm. Detachable chains do not require lubrication.

## Pintle and Welded Steel Chains

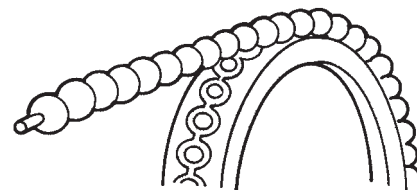
The **pintle and welded steel chains** shown in Figure 17.22 are a combination design between the detachable and the offset sidebar roller chain. They are used for applications similar to the detachable chain where more rigorous service is required for up to 40 HP and 425 fpm. Lubrication is not required, so they may also be used where lubrication is not effective, such as dusty or wet conditions.

## LIGHT-DUTY CHAIN

**Light-duty chains** are designed for application in low-power situations such as equipment control mechanisms for computers and printers or appliance controls.

## Bead Chain

**Bead chains** are commonly used for control mechanisms for light-duty, low-power applications. Bead chains are rated from 15 to 75 pounds and are available in standard bead diameters of 3/32, 1/8, 3/16, and 1/4 in. (see Figure 17.23).



© Cengage Learning 2012

FIGURE 17.23 Bead chain.

## CHAIN DRIVE DESIGN

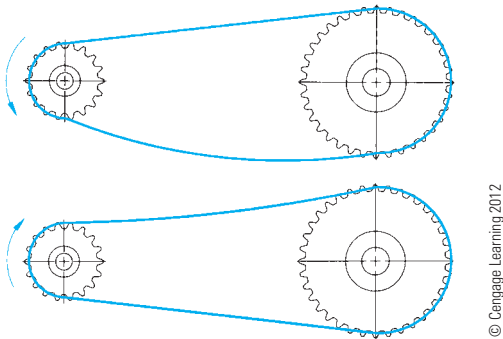
Chain drives have some of the same characteristics as belt drives in the following ways:

- Chains elongate when in operation, thus requiring shaft adjustment or link removal to maintain proper tightness.
- Chains have a tight side and a slack side when in operation.

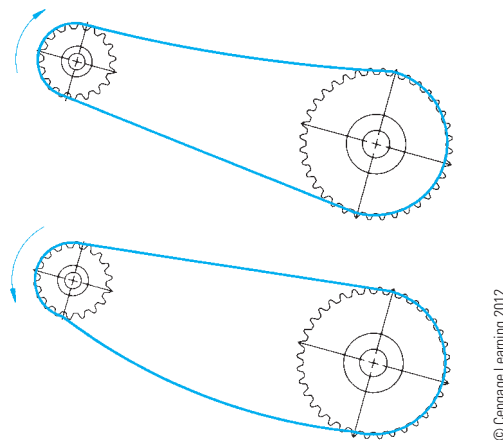
The design and direction of rotation of the driver sprocket and the driven sprocket are important to the proper function of the chain drive mechanism. For chain drives with long center distances, the slack side should be on the bottom, because upper-side slack could cause the chain on the top to meet the bottom as the chain elongates. Figure 17.24 shows the recommended and not recommended design arrangements.

On short center drive design arrangements, the slack side should be on the bottom because slack on the top could cause the chain to jump out of the sprocket as shown in Figure 17.25. The relationship of the shaft centers is also important. The shaft centers should be designed in a horizontal position or inclined no more than 45°. When the shafts are inclined up to 45°, the slack side can be on either the top or bottom (see Figure 17.26).

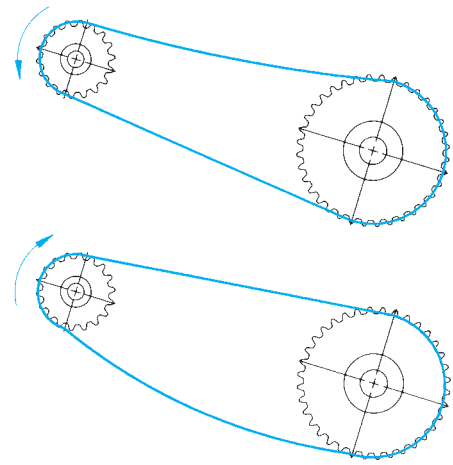
Shaft design arrangements between 45° and vertical should be avoided. However, when they are required due to the machine design, the chain should be kept tighter than normal



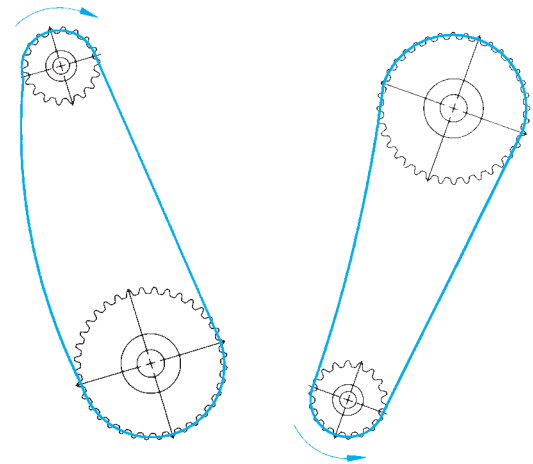
**FIGURE 17.24** Chain drives with long center distance should have slack on bottom side.



**FIGURE 17.25** Chain drives with short center distances should have slack on the lower side.



**FIGURE 17.26** Chain drive shaft centers should be on a horizontal line or on a line inclined not more than 45°, in which case the slack can be on the upper or lower side.



**FIGURE 17.27** When the shaft centers are aligned more than 45° from horizontal, the slack side should be in the side closest to horizontal.

applications. This type of arrangement requires that the chain be tightened frequently. Properly designed situations with the shafts inclined greater than 45° provide for the slack to be on the side closest to horizontal (see Figure 17.27).

## ROLLER CHAIN DRIVE SELECTION

Designing roller chain drives includes selecting the sprocket sizes, the chain pitch, the chain length, the distance between shaft centers, and the lubrication requirements. Factors that contribute to selecting the proper chain drive variable are rpm of the sprockets, the **horsepower (HP)** of the motor, and the load conditions.

Chain manufacturers provide formulas and catalogs for the design and selection of chain drives. The following discussion is based on engineering data provided in the Morse Power Transmission Products catalog, provided by the Morse Industrial Products Division, Emerson Power Transmission Corporation.

A chain drive is required for a 2 HP electric motor operating laundry machinery. The drive sprocket turns at 1800 rpm,



which produces 900 rpm at the driven sprocket. The approximate center distance is 12 in.

**STEP 1** Determine the design horsepower. The design HP of a machine takes into account the type of service and the efficiency of the machine. A service factor is applied to the horsepower rating of the drive motor to determine the design horsepower of a chain drive. The service factors are established by the power source, the nature of the load, and the strain or shock on the drive. Three basic operating characteristics are used to establish the service factors (see Figure 17.28).

Now determine the service factor for the given problem. You have a 2 HP electric motor operating laundry machinery. Laundry machinery operates under

moderate shock. Refer to the table in Figure 17.29 to determine the service factor. An electric motor operating under moderate shock has a service factor of 1.3.

**Smooth:** Running load is fairly uniform. Starting and peak loads may be somewhat greater than running load, but occur infrequently.

**Moderate Shock:** Running load is variable. Starting and peak loads are considerably greater than running load and occur frequently.

**Heavy Shock:** Starting loads are extremely heavy. Peak loads and overloads occur continuously and are of maximum fluctuation.

FIGURE 17.28 Step 1: Chain drive operating classifications. Courtesy Morse Industrial

SERVICE FACTORS

Service Factors are selected below for various applications after first determining the prime mover or power source type.

SERVICE FACTOR TABLE

APPLICATION	Type of Prime Mover		APPLICATION	Type of Prime Mover		APPLICATION	Type of Prime Mover	
	A	B		A	B		A	B
AGITATORS (paddle or propeller) Pure liquid Liquids—variable density	1.1 1.2	1.3 1.4	CRUSHING MACHINERY Ball mills, crushing rolls, jaw crushers	1.6	1.8	PAPER INDUSTRY MACHINERY Agitators, bleachers Barker—mechanical Beater, Yankee dryer Calendars, dryer & paper machines Chippers & winder drums	1.1 1.6 1.3 1.2 1.5	1.3 1.8 1.5 1.4 1.7
BAKER MACHINERY Dough mixer	1.2	—	DREDGES Conveyors, cable reels Jigs & screens Cutter head drives Dredge pumps	1.4 1.6 Consult Morse See Pumps	1.6 1.8	PRINTING MACHINERY Embossing & flat bed presses, folders Paper cutter, rotary press & linotype machine Magazine & newspaper presses	1.2	—
BLOWERS	See Fans		FANS & BLOWERS Centrifugal, propeller, vane Positive blowers (lobe)	1.3 1.5	1.5 1.7	PUMPS Centrifugal, gear, lobe & vane Dredge Pipe line Reciprocating 3 or more cyl. 1 or 2 cyl.	1.2 1.6 1.4 1.3 1.6	— 1.4 1.8 1.6 1.5 1.8
BREWING & DISTILLING EQUIPMENT Bottling machinery Brew kettles, cookers, mash tubs Scale hopper—frequent starts	1.0 1.0 1.2	— — —	GRAIN MILL MACHINERY Sifters, purifiers, separators Grinders and hammer mills Roller mills	1.1 1.2 1.3	1.3 1.4 1.5	RUBBER & PLASTICS INDUSTRY EQUIPMENT Calendars, rolls, tubers Tire-building and Banbury mills Mixers and sheeters Extruders	1.5 1.6 1.5	1.7 1.8 1.7
BRICK & CLAY EQUIPMENT Auger machines, cutting table Brick machines, dry press, & granulator Mixer, pug mill, & rolls	1.3 1.4 1.4	1.5 1.6 1.6	GENERATORS & EXCITERS	1.2	1.4	SCREENS Conical & revolving Rotary, gravel, stone & vibrating	1.2 1.5	1.4 1.7
CENTRIFUGES	1.4	1.6	MACHINE TOOLS Grinders, lathes, drill press Boring mills, milling machines	1.0 1.1	— —	STOKERS	1.1	—
COMPRESSORS Centrifugal & rotary (lobe) Reciprocating 1 or 2 cyl. 3 or more	1.1 1.6 1.3	1.3 1.8 1.5	MARINE DRIVES	Consult Morse		TEST STANDS & DYNAMOMETERS	Consult Morse	
CONSTRUCTION EQUIPMENT OR OFF-HIGHWAY VEHICLES Drive line duty, power take-off, accessory drives	Consult Morse		MILLS Rotary type: Ball, pebble, rod, tube, roller Dryers, kilns, & tumbling barrels Metal type: Draw bench carriage & main drive Forming machines	1.5 1.6 1.5 Consult Morse	1.7 1.8	TEXTILE INDUSTRY Spinning frames, twisters, wrappers & reels Batchers, calendars & looms	1.0 1.1	— —
CONVEYOR Apron, bucket, pan & elevator Belt (ore, coal, sand, salt) Belt—light package, oven Screw & flight (heavy duty)	1.4 1.2 1.0 1.6	1.6 1.4 1.2 1.8	MIXERS Concrete Liquid & semi-liquid	1.6 1.1	1.8 1.3			
CRANES & HOISTS Main hoist—medium duty Main hoist—heavy duty, skip hoist	1.2 1.4	1.4 1.6	OIL INDUSTRY MACHINERY Compounding units Pipe line pumps Slush pumps Draw works Chillers, paraffin filter presses, kilns	1.1 1.4 1.5 1.8 1.5	1.3 1.6 1.7 2.0 1.7			

FIGURE 17.29 Chain drive service factors. Courtesy Morse Industrial

Establish the design horsepower using the formula:

$$\text{Motor HP} \times \text{Service Factor} = \text{Design HP}$$

For the sample problem, the design HP is:

$$2 \text{ HP} \times 1.3 = 2.6 \text{ Design HP}$$

**STEP 2** Determine the number of teeth of the drive sprocket. Now that you know the design HP (2.6 HP) and the rpm of the drive sprocket (1800 rpm), you can determine the number of teeth of the drive sprocket. The drive sprocket is normally the small sprocket as shown in the left column of the chart in Figure 17.30. Look at Figure 17.30 and find the “Revolutions per Minute—Small Sprocket” highlighted along the top horizontal column. Move down the 1800 rpm column until you find a design HP equal to or greater than the design HP of 2.6 for the sample problem. Find 2.93 highlighted in Figure 17.30. Now move horizontally to the left from 2.93 to find the number of teeth of the small sprocket in the left column. Notice that 40 teeth is highlighted in Figure 17.30.

**STEP 3** Determine the chain pitch, or the center distance between pins of one chain link (see Figure 17.31). The number of teeth of the small sprocket is taken from the horsepower rating table for a chain with a specific pitch. If you look back at Figure 17.30, you can see the pitch identified in the heading as No. 25-1/4" pitch. Chains are manufactured with standard size pitches available in increments from 1/4 to 3 in. Chains are also classified by number. For example, a 1/4 in. pitch is No. 25, a 3/8 in. pitch is No. 35, a 1/2 in. pitch is No. 40, and a 5/8 in. pitch is No. 50.

**STEP 4** Determine the ratio and the number of teeth for the driven sprocket. The chain drive ratio is the relationship between the drive and driven sprockets. The ratio is determined by dividing the rpm of the driver by the rpm of the driven sprocket. If you use the sample problem, then the driver is 1800 rpm and the driven is 900 rpm. The ratio is 1800 rpm/900 rpm = 2:1. Now multiply the number of teeth of the small sprocket by the ratio to get the number of teeth for the large sprocket: 40 (teeth small sprocket) × 2 (ratio) = 80 teeth large sprocket.

**No. 25—1/4" pitch standard single strand roller chain**

No. of Teeth Small Spkt.	Revolutions per Minute—Small Sprocket																								
	50	100	300	500	700	900	1200	1500	1800	2100	2500	3000	3500	4000	4500	5000	5500	6000	6500	7000	7500	8000	8500	9000	10000
12	0.03	0.06	0.16	0.25	0.34	0.43	0.55	0.68	0.80	0.92	1.07	1.26	1.45	1.57	1.32	1.12	0.97	0.86	0.76	0.68	0.61	0.56	0.51	0.47	0.40
13	0.04	0.06	0.17	0.27	0.37	0.47	0.60	0.74	0.87	1.00	1.17	1.38	1.58	1.77	1.49	1.27	1.10	0.96	0.86	0.77	0.69	0.63	0.57	0.53	0.45
14	0.04	0.07	0.19	0.30	0.40	0.50	0.65	0.80	0.94	1.08	1.27	1.49	1.71	1.93	1.66	1.42	1.23	1.08	0.96	0.86	0.77	0.70	0.64	0.59	0.50
15	0.04	0.07	0.20	0.32	0.43	0.54	0.70	0.86	1.01	1.17	1.36	1.61	1.85	2.08	1.84	1.57	1.36	1.20	1.06	0.95	0.86	0.78	0.71	0.65	0.56
16	0.04	0.08	0.22	0.34	0.47	0.58	0.76	0.92	1.09	1.25	1.46	1.72	1.98	2.23	2.03	1.73	1.50	1.32	1.17	1.05	0.94	0.86	0.78	0.72	0.61
17	0.05	0.08	0.23	0.37	0.50	0.62	0.81	0.99	1.16	1.33	1.56	1.84	2.11	2.38	2.22	1.90	1.64	1.44	1.28	1.14	1.03	0.94	0.86	0.79	0.67
18	0.05	0.09	0.25	0.39	0.53	0.66	0.86	1.05	1.24	1.42	1.66	1.96	2.25	2.53	2.42	2.07	1.79	1.57	1.39	1.25	1.12	1.02	0.93	0.86	0.73
19	0.05	0.09	0.26	0.41	0.56	0.70	0.91	1.11	1.31	1.50	1.76	2.07	2.38	2.69	2.62	2.24	1.94	1.70	1.51	1.35	1.22	1.11	1.01	0.93	0.79
20	0.06	0.10	0.28	0.44	0.59	0.74	0.96	1.15	1.38	1.59	1.86	2.19	2.52	2.84	2.83	2.42	2.10	1.84	1.63	1.46	1.32	1.20	1.09	1.00	0.86
21	0.06	0.11	0.29	0.46	0.62	0.78	1.01	1.24	1.46	1.68	1.96	2.31	2.66	2.99	3.05	2.60	2.26	1.98	1.76	1.57	1.42	1.29	1.17	1.08	0.92
22	0.06	0.11	0.31	0.48	0.66	0.82	1.07	1.30	1.53	1.76	2.06	2.43	2.79	3.15	3.27	2.79	2.42	2.12	1.88	1.69	1.52	1.38	1.26	1.16	0.99
23	0.06	0.12	0.32	0.51	0.69	0.86	1.12	1.37	1.61	1.85	2.16	2.55	2.93	3.30	3.50	2.98	2.59	2.27	2.01	1.80	1.62	1.47	1.35	1.24	1.06
24	0.07	0.13	0.34	0.53	0.72	0.90	1.17	1.43	1.69	1.94	2.27	2.67	3.07	3.46	3.73	3.18	2.76	2.42	2.15	1.92	1.73	1.57	1.44	1.32	1.12
25	0.07	0.13	0.35	0.56	0.75	0.94	1.22	1.50	1.76	2.02	2.37	2.79	3.21	3.61	3.96	3.38	2.93	2.57	2.28	2.04	1.84	1.67	1.53	1.40	1.20
26	0.07	0.14	0.37	0.58	0.79	0.98	1.28	1.56	1.84	2.11	2.47	2.91	3.34	3.77	4.19	3.59	3.11	2.73	2.42	2.17	1.95	1.77	1.62	1.49	1.27
28	0.08	0.15	0.40	0.63	0.85	1.07	1.38	1.69	1.99	2.29	2.68	3.15	3.62	4.09	4.54	4.01	3.47	3.05	2.70	2.42	2.18	1.98	1.81	1.66	1.42
30	0.08	0.16	0.43	0.68	0.92	1.15	1.49	1.82	2.15	2.46	2.88	3.40	3.90	4.40	4.89	4.45	3.85	3.38	3.00	2.68	2.42	2.20	2.01	1.84	1.57
32	0.09	0.17	0.46	0.73	0.98	1.23	1.60	1.95	2.30	2.64	3.09	3.64	4.18	4.72	5.25	4.90	4.25	3.73	3.30	2.96	2.67	2.42	2.21	2.03	1.73
35	0.10	0.19	0.51	0.80	1.08	1.36	1.76	2.15	2.53	2.91	3.41	4.01	4.61	5.20	5.78	5.60	4.86	4.26	3.78	3.38	3.05	2.77	2.53	2.32	1.98
40	0.12	0.22	0.58	0.92	1.25	1.57	2.03	2.48	2.93	3.36	3.93	4.64	5.32	6.00	6.68	6.85	5.93	5.21	4.62	4.13	3.73	3.38	3.09	2.83	2.42
45	0.13	0.25	0.66	1.05	1.42	1.78	2.31	2.82	3.32	3.82	4.47	5.26	6.05	6.82	7.58	8.17	7.08	6.21	5.51	4.93	4.45	4.04	3.69	3.38	2.89
	TYPE A					TYPE B										TYPE C									

TYPE A: Manual or Drip Lubrication (500 fpm max.)

TYPE B: Bath or Disc Lubrication (3500 fpm max.)

TYPE C: Oil Stream Lubrication (Up to max. speed shown).

The limiting RPM for each lubrication type is read from the column to the left of the boundary line shown.

The ratings on this page are in accordance with the standards of the American Chain Association, Copyright 1974.

For Multi-Strand Chain use

No. of Strands	Strand Factor
2	1.7
3	2.5
4	3.3

FIGURE 17.30 Step 2: Horsepower ratings for single-strand roller chain. Courtesy Morse Industrial

**STEP 5** Determine the center distance in chain pitches. As a general rule, the preferred center distance between shafts is between 30 and 50 chain pitches. The maximum recommended spacing between centers is 80 pitches. This is to help ensure that there is clearance between the two sprockets and to allow for a minimum of 118° of chain contact around the small sprocket (see Figure 17.32). The center distance between shafts should be no less than the difference between sprocket diameters for ratios greater than 3:1. To determine the center distance in chain pitches, divide the center distance by the chain pitch. For the sample problem, this is:

$$\frac{12 \text{ in. (Center Distance)}}{0.25 \text{ in. (Pitch)}} = 48 \text{ Chain Pitches}$$

**STEP 6** Determine the chain length. First, determine the chain length in pitches using the formula:

$$2C + \frac{S}{2} + \frac{K}{C}, \text{ where:}$$

C = Center distances between sprockets in chain pitches.

S = Number of teeth in small sprocket plus number of teeth in large sprocket.

K = Number of teeth in large sprocket minus number of teeth in small sprocket equals D. Look at the table in Figure 17.33 to find the value K corresponding to D.

For the same problem:

$$C = 48 \text{ (from Step 5)}$$

$$S = 40 + 80 = 118$$

$$K = 80 - 40 = 40$$

$$D = 40$$

Look at Figure 17.33 to find K 40.53.

$$2C + \frac{S}{2} + \frac{K}{C} = 2(48) + \frac{120}{2} + \frac{40.53}{48}$$

$$= 96 + 60 + .84 = 156.84$$

The chain length in pitches must be the next higher whole number, because you cannot have a partial chain pitch. So, 156.84 = 157 chain length in pitches. Whenever possible, use an even number of chain pitches. Using an odd number of chain pitches requires an offset link, which is not preferred. For this

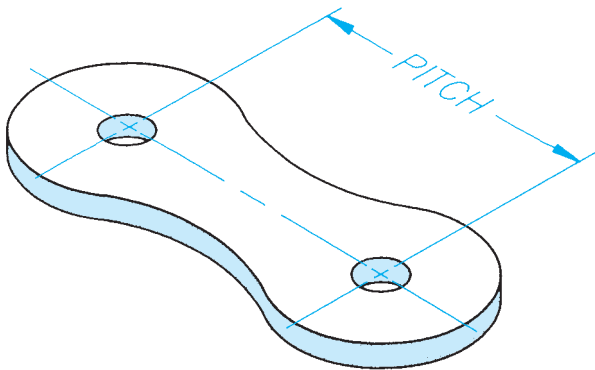


FIGURE 17.31 Step 3: Chain pitch. © Cengage Learning 2012

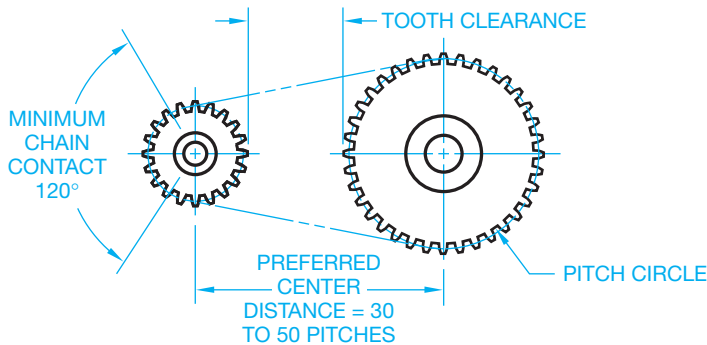


FIGURE 17.32 Step 5: The center distance between shafts and 118° minimum recommended chain contact. © Cengage Learning 2012

D	K	D	K	D	K	D	K
32	25.94	63	100.54	94	223.82	125	395.79
33	27.58	64	103.75	95	228.61	126	402.14
34	29.28	65	107.02	96	233.44	127	408.55
35	31.03	66	110.34	97	238.33	128	415.01
36	32.83	67	113.71	98	243.27	129	421.52
37	34.68	68	117.13	99	248.26	130	428.08
38	36.58	69	120.60	100	253.30	131	434.69
39	38.53	70	124.12	101	258.39	132	441.36
40	40.53	71	127.69	102	263.54	133	448.07
41	42.58	72	131.31	103	268.73	134	454.83
42	44.68	73	134.99	104	273.97	135	461.64
43	46.84	74	138.71	105	279.27	136	468.51
44	49.04	75	142.48	106	284.67	137	475.42
45	51.29	76	146.31	107	290.01	138	482.39
46	53.60	77	150.18	108	295.45	139	489.41
47	55.95	78	154.11	109	300.95	140	496.47
48	58.36	79	158.09	110	306.50	141	503.59
49	60.82	80	162.11	111	312.09	142	510.76
50	63.33	81	166.19	112	317.74	143	517.98
51	65.88	82	170.32	113	323.44	144	525.25
52	68.49	83	174.50	114	329.19	145	532.57
53	71.15	84	178.73	115	334.99	146	539.94
54	73.86	85	183.01	116	340.84	147	547.36
55	76.62	86	187.34	117	346.75	148	554.83
56	79.44	87	191.73	118	352.70	149	562.36
57	82.30	88	196.16	119	358.70	150	569.93
58	85.21	89	200.64	120	364.76	151	577.56
59	88.17	90	205.18	121	370.86	152	585.23
60	91.19	91	209.76	122	377.02	153	592.96
61	94.25	92	214.40	123	383.22	154	600.73
62	97.37	93	219.08	124	389.48	155	608.56

FIGURE 17.33 Step 6: Sprocket teeth factors “K.” Courtesy Morse Industrial

problem, therefore, use 158 chain length in pitches rather than 157. Now multiply the chain length in pitches by the chain pitch to find the chain length in inches:

$$158 \times .25 = 39.5 \text{ in. of chain length}$$

**STEP 7** Determine chain lubrication. Correct lubrication is important in maintaining long life for chain drives. Lubrication methods are governed by the speed and function of the machine. Periodic manual lubrication works well for slow-speed chain drives. To do this, use a brush to apply a medium-consistency mineral oil while a machine is stopped. For moderate-speed

chain drives, a drip system is often designed to keep the chain lubricated. For high-speed chain drives, an oil bath or an oil spray is often provided. To determine the type of oil application recommended for the sample problem, refer back to the chart in Figure 17.30. Notice the notes Type A, Type B, and Type C at the bottom of the chart. These refer to the recommended lubrication as follows:

- Type A = Manual or drip lubrication.
- Type B = Bath or disc lubrication.
- Type C = Oil stream lubrication.

Notice the HP rating of 2.93 for the sample problem falls in the Type B lubrication category.

## PROFESSIONAL PERSPECTIVE

This chapter covers the use of vendors' catalogs to find specific belt and chain drives for a given application. As a drafter in any engineering field, you will find that using vendors' catalogs and specifications is a very important part of your job. Most companies have a complete library of catalogs of purchase parts. Purchase parts, often referred to as *standard parts*,

are products that can be purchased already made. Common purchase parts are bolts, nuts, belts, chains, and sprockets. You should become familiar with the types of purchase parts your company uses and how to find them in the vendors' catalogs. Also determine the suppliers that have the best prices, highest quality, and fastest availability.

### BELT LENGTH

**Problem:** Find the length of a driving belt running around two pulleys of radii 14" and 8" if the distance between the centers of the two pulleys is 25", as shown in Figure 17.34.

**Solution:** The formula for belt length between two pulleys is

$$L = 2(d)(\cos\theta) + \pi(R + r) + 20(R - r)$$

where  $\theta = \text{Inv sin} \left( \frac{R - r}{d} \right)$

**Inv sin** stands for **inverse sine** and means "angle whose sine is." For example,  $\text{Inv sin } .7$  is equal to  $44.4^\circ$  (or .775 radians) because  $\sin 44.4^\circ = .7$ . It is important to note that this formula requires angle to be in **radian** measure. The first step in this rather complicated formula to find L is to

determine. It is easiest to put your calculator in the **radian mode** to work this problem:

$$\theta = \text{Inv sin} \left( \frac{14 - 8}{25} \right) = \text{Inv sin } .24 = .2424 \text{ radians}$$

Then substituting into the formula for L:

$$L = 2(25)(\cos .2424) + \pi(14 + 8) + 2(.2424)(14 - 8)$$

$$L = 2(25)(.9708) + \pi(22) + 2(.2424)(6)$$

$$L = 48.54 + 69.12 + 2.91 = 118.57"$$

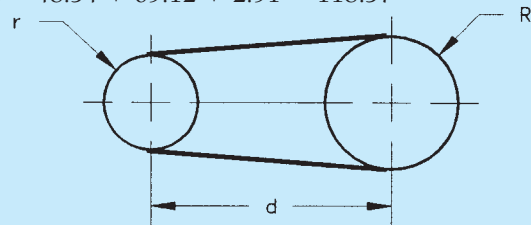


FIGURE 17.34 Drive belt around pulleys.


## WEB SITE RESEARCH

The following Web sites can assist you in doing additional research on subjects such as standards, gears, cams, linkages, bearings, and related areas.

Address	Company, Product, or Service
www.sae.org	Society of Automotive Engineers (SAE)
www.industrialpress.com	<i>Machinery's Handbook</i> : Gear, cam, linkage, and bearing-related information and specifications
www.phoenix-mfg.com	Phoenix Manufacturing: Pulleys and idlers
www.dxpe.com	Industrial V-belts
www.igus.com	IGUS Corporation: Bearings and chains
www.teleflexmorse.com	Teleflex Morse: Industrial products
www.emerson-ept.com	Emerson Power Transmission: Producer of power transmission drives, components, and bearings

# Chapter 17

## Chapter 17 Belt and Chain Drives Test

 To access the Chapter 17 test, go to the Student CD, select **Chapter Tests and Problems**, and then **Chapter 17**. Answer the questions

with short, complete statements, sketches, or drawings as needed. Confirm the preferred submittal process with your instructor.

## Chapter 17 Belt and Chain Drives Problems

### INSTRUCTIONS

#### Belt Drive Problems

##### Part 1: Problems 17.1 Through 17.9

Solve Problems 17.1 through 17.9 using the information and tables given in this chapter and in Figure 17.35. All motors are AC motors with normal torque, squirrel cage, synchronous, and split phase, or shunt-wound DC motors, or multiple cylinder internal combustion engines. Include the following information with each solution:

- Service factor.
- Design horsepower.

- Driven speed.
- Pitch diameter driver and driven.
- Belt section.
- Number of belts.
- Belt number and center distance.
- Corrected horsepower.
- Belt drive ratio.
- Belt velocity of driver sheave.

1.50	12.0	18.0	A	1	10	—	—	—	1167	10.57	13.63	A77	15.3	0.96	A81	17.3	0.98	A85	19.4	0.99
1.50	12.0	18.0	C	2	12	—	—	—	1167	25.92	31.20	C75	15.1	0.82	C96	25.7	0.88	C112	33.8	0.92
1.50	13.0	19.5	A	1	3	—	—	—	1167	11.07	14.40	A83	16.3	0.98	A86	17.8	0.99	A89	19.4	0.99
1.51	3.7	5.6	A	1	3	2318	4.61	5.62	1159	2.94	3.71	A24	5.3	0.76	A35	10.8	0.84	A45	15.8	0.88
1.51	3.9	5.9	B	1	3	2318	4.64	8.35	1159	3.53	5.53	B28	7.1	0.73	B45	15.7	0.84	B56	21.2	0.89
1.53	3.4	5.2	B	1	6	2288	2.90	6.59	1144	2.43	4.44	B28	8.1	0.73	B45	16.6	0.84	B56	22.1	0.89
1.53	3.6	5.5	A	1	3	2288	4.42	5.37	1144	2.81	3.55	A24	5.4	0.76	A35	11.0	0.84	A45	16.0	0.88
1.53	3.6	5.5	3V	1	4	2288	6.28	7.30	1144	3.63	4.07	3V250	5.3	0.78	3V300	7.8	0.83	3V355	10.6	0.85
1.53	3.8	5.8	A	1	6	2288	4.81	5.87	1144	3.06	3.86	A24	5.0	0.76	A35	10.6	0.84	A45	15.6	0.88
1.53	3.8	5.8	B	1	6	2288	4.31	8.01	1144	3.31	5.32	B28	7.3	0.73	B45	15.8	0.84	B56	21.3	0.89
1.54	2.4	3.7	A	1	1	2273	1.85	2.12	1136	1.27	1.61	A24	7.8	0.79	A35	13.3	0.86	A45	18.3	0.90
1.54	2.6	4.0	A	1	2	2273	2.31	2.70	1136	1.54	1.94	A24	7.4	0.79	A35	12.9	0.84	A45	18.0	0.90
1.54	3.5	5.4	A	1	3	2273	4.22	5.12	1136	2.69	3.40	A24	5.6	0.76	A35	11.1	0.84	A45	16.1	0.88
1.54	3.7	5.7	A	1	3	2273	4.62	5.62	1136	2.94	3.71	A24	5.2	0.76	A35	10.7	0.84	A45	15.7	0.88
1.54	3.9	6.0	B	1	3	2273	4.66	8.36	1136	3.53	5.54	B28	7.0	0.73	B45	15.6	0.84	B56	21.1	0.89

FIGURE 17.35 Nominal center distances, number of belts, and arc length factor chart. © Cengage Learning 2012

**PROBLEM 17.1** A 3 HP, 1750 rpm motor is to operate a furnace blower having a shaft speed of approximately 1115 rpm under normal service. The center distance between the motor and blower shafts is about 16 in.

**PROBLEM 17.2** A 3 HP, 1750 rpm motor is used to operate a drill press speed reducer under intermittent service. The spindle speed is about 1136 rpm. The center distance between the motor and spindle shafts is about 18.5 in.

**PROBLEM 17.3** A 1 1/2 HP, 1750 rpm electric motor is used to operate a woodworking band saw with the blade turning at 1144 rpm, intermittent service. The center-to-center distance is about 16 in.

**PROBLEM 17.4** A 2 HP electric motor with a shaft speed of 1750 rpm operates a printing machine at normal service. The shaft on the printing machine is to operate at 1167 rpm. The center-to-center distance is about 18 in.

**PROBLEM 17.5** A 2 HP electric motor with a shaft speed of 1750 rpm operates a punch machine at continuous service. The shaft on the punch machine is to operate at 1108 rpm. The center-to-center distance is about 17 in.

**PROBLEM 17.6** A 1.5 HP motor with a shaft speed of 1750 rpm operates a compressor at normal service. The shaft on the compressor is to operate at 1167 rpm. The center-to-center distance is about 18 in.

**PROBLEM 17.7** A 2 HP electric motor with a shaft speed of 1750 rpm operates a printing machine at normal service. The shaft on the printing machine is to operate at 1115 rpm. The center-to-center distance is about 17.5 in.

**PROBLEM 17.8** A drive is required for a 18 HP (horsepower) motor driving a fan 16 hours per day. The motor speed is 3600 rpm and the shaft size is 1.625 in. The fan speed is approximately 2250 rpm and the fan shaft is 1.438 in. The center distance is 38 in. minimum and 41 in. maximum.

**PROBLEM 17.9** Given the following layout, prepare a detail drawing of the pulley on appropriately sized ASME sheet with border and sheet block, unless otherwise specified by your instructor (in). Use the sheet size, border, title block and tolerance instructions provided in Chapter 10, *Dimensioning and Tolerancing*.

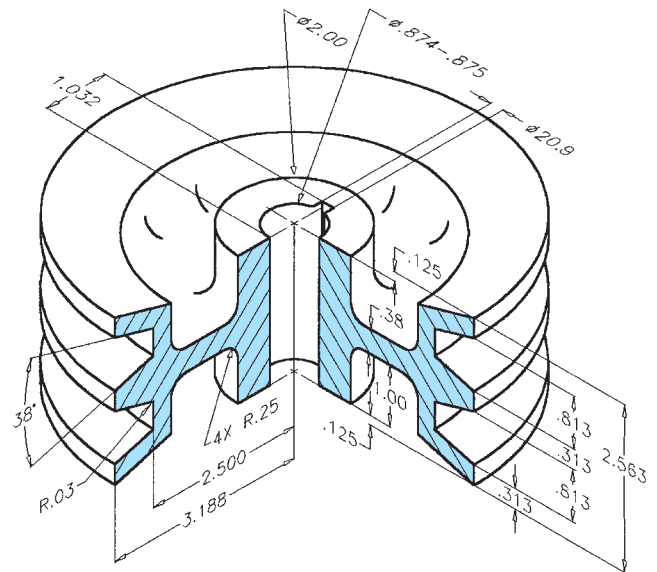
Part Name: Pulley

Material: Aluminum



## Drafting Templates

To access CADD template files with predefined drafting settings, go to the Student CD, select **Drafting Templates**, and then select the appropriate template file.



© Cengage Learning 2012

## Chain Drive Problems

### Part 2: Problems 17.10 Through 17.16

Solve Problems 17.10 through 17.16 using the information and tables given in this chapter. Include the following information with each solution:

- Service factor.
- Design horsepower.
- Number of teeth drive sprocket and driven sprocket.
- Chain pitch.
- Ratio.
- Center distance in chain pitches.
- Chain length.
- Lubrication.

**PROBLEM 17.10** A chain drive is required for a 1.5 HP electric motor operating a paper machine. The drive sprocket turns 1500 rpm, and the driven sprocket turns 600 rpm. The shaft center distance is about 19 in.

**PROBLEM 17.11** A chain drive is required for a 1/10 HP electric motor operating a speed reducer for a belt light package conveyor. The drive sprocket turns 50 rpm, and the driven sprocket turns 17 rpm. The shaft center distance is about 17 in.

**PROBLEM 17.12** A chain drive is required for a 1 HP electric motor operating a centrifuge. The drive sprocket turns 10,000 rpm, and the driven sprocket turns 4000 rpm. The shaft center distance is about 18 in.

**PROBLEM 17.13** A chain drive is required for a 2 HP electric motor operating a centrifugal pump. The drive sprocket turns 5500 rpm, and the driven sprocket turns 1550 rpm. The shaft center distance is about 14 in.

**PROBLEM 17.14** A chain drive is required for a 2 HP electric motor operating laundry machinery. The drive sprocket turns at 1800 rpm, which produces 900 rpm at the driven sprocket. The approximate center distance is 12 in.

**PROBLEM 17.15** A chain drive is required for a 2.5 HP internal combustion tractor engine operating a generator. The drive sprocket turns 3000 rpm, and the driven sprocket turns 1800 rpm. The shaft center distance is about 18 in.

**PROBLEM 17.16** A chain drive is required for a 2 HP electric motor operating a pure liquid agitator. The drive sprocket turns 2100 rpm, and the driven sprocket turns 700 rpm. The shaft center distance is about 18 in.

### Part 3: Problems 17.17 Through 17.23



To access the Chapter 17 problems, go to the Student CD, select **Chapter Tests and Problems** and **Chapter 17**, and then open the problem of your choice or as assigned by your instructor. Solve the problems using the instructions provided on the CD, unless otherwise specified by your instructor.

### Math Problems

#### Part 4: Problems 17.24 Through 17.29



To access the Chapter 17 problems, go to the Student CD, select **Chapter Tests and Problems** and **Chapter 17**, and then open the math problem of your choice or as assigned by your instructor. Solve the problems using the instructions provided on the CD, unless otherwise specified by your instructor.

## Welding Processes and Representations

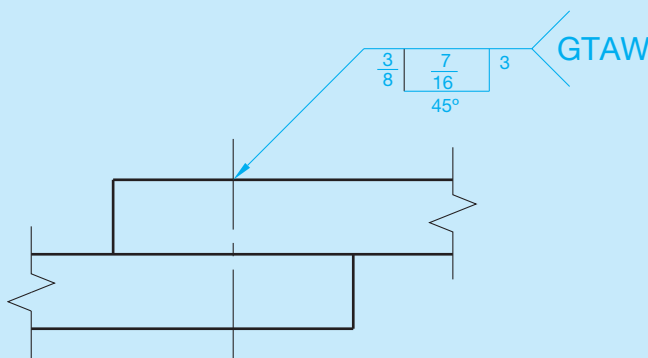
### LEARNING OBJECTIVES

After completing this chapter, you will:

- Identify welding processes.
- Draw welding representations and provide proper welding symbols and notes.
- Draw weldments from engineering sketches and actual industrial layouts.

### THE ENGINEERING DESIGN APPLICATION

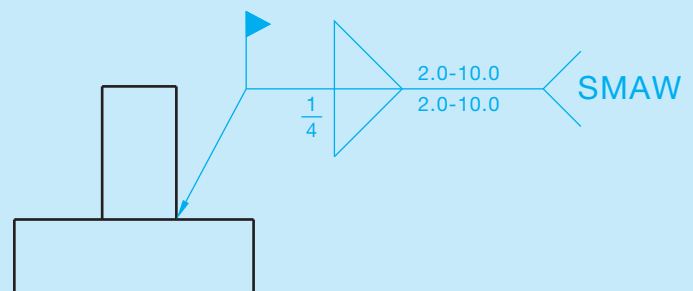
The engineer has just handed you a sketch showing the details for a couple of weldments. The welding details are not shown as standard welding symbols but rather as written instructions, and it is up to you to design the appropriate weld and welding symbols for the weldment drawing. The first weldment sketch shows an assembly of two aluminum bars connected in a lap joint. The instructions are as follows: “Use 3/8 in. plug weld, 7/16 in. deep with a 45° included angle. Space the welds at 3 in. on center, for the length of the material.”



**FIGURE 18.1** Drawing with plug weld symbol created from engineering sketch and related information. Dimension values in this figure are in inches.

Because aluminum welding requires special considerations, you examine the thickness of the material and decide on a gas tungsten arc welding process. Using this information, you design the weld symbol shown in Figure 18.1.

The second weldment sketch shows two low-carbon steel plates joined in a T-joint. The instructions are: “Use 1/4 in. intermittent fillet weld on both sides. The welds should be 2 in. long with a pitch of 10 in. and staggered. Field weld at installation site.” The low-carbon steel material and T-joint suggest a shielded metal arc welding process, and you design the appropriate symbol shown in Figure 18.2.



**FIGURE 18.2** Drawing with fillet weld symbol created from engineering sketch and related information. Dimension values in this figure are in inches. © Cengage Learning 2012

**Welding** is a process of joining two or more pieces of like metals by heating the material to a temperature high enough to cause softening or melting. The location of the weld is where the materials combine their grain structure from one piece to the other. The parts that are welded become one, and the properly welded joint is as strong or stronger than the original material. Welding can be performed with or without pressure applied to the materials. Some materials can be welded together

by pressure alone. Most welding operations are performed by filling a heated joint between pieces with molten metal.

Welding is a method of fastening adjacent parts. Welding was not discussed with fasteners in Chapter 11, *Fasteners and Springs*, because the weld is a more permanent fastening application than screw threads or pins, for example. Welding is a common fastening method used in many manufacturing applications and industries from automobile to aircraft manufacturing,



and from computers to ship building. Some of the advantages of welding over other fastening methods include better strength, better weight distribution and reduction, a possible decrease in the size of castings or forgings needed in an assembly, and a potential saving of time and manufacturing costs.

## WELDING PROCESSES

There are a number of welding processes available for use in industry as identified in Figure 18.3. The most common welding processes include oxygen gas welding, shielded metal arc welding, gas tungsten arc welding, and gas metal arc welding.

### Oxygen Gas Welding

Oxygen gas welding, commonly known as oxyfuel welding or oxyacetylene welding, also can be performed with fuels such as natural gas, propane, and propylene. Oxyfuel welding is most

typically used to fabricate thin materials, such as sheet metal and thin-wall pipe or tubing. Oxyfuel processes are also used for repair work and metal cutting. One advantage of oxyfuel welding is that the equipment and operating costs are less than with other methods. But other welding methods have advanced over the oxyfuel process because they are faster, cleaner, and cause less material distortion. Common oxyfuel welding and cutting equipment is shown in Figure 18.4.

Also associated with oxyfuel applications are soldering, brazing, and braze welding. These methods are more of a bonding process than welding, because the base material remains solid while a filler metal is melted into a joint. Soldering and brazing differ in application temperature. **Soldering** is done below 840°F (450°C) and brazing above 840°F (450°C). Like alloys may be used, depending on their melting temperatures. The filler generally associated with soldering is solder. **Solder** is an alloy of tin and lead. The filler metal associated with brazing is an alloy of copper and zinc. **Brazing** is a process of joining

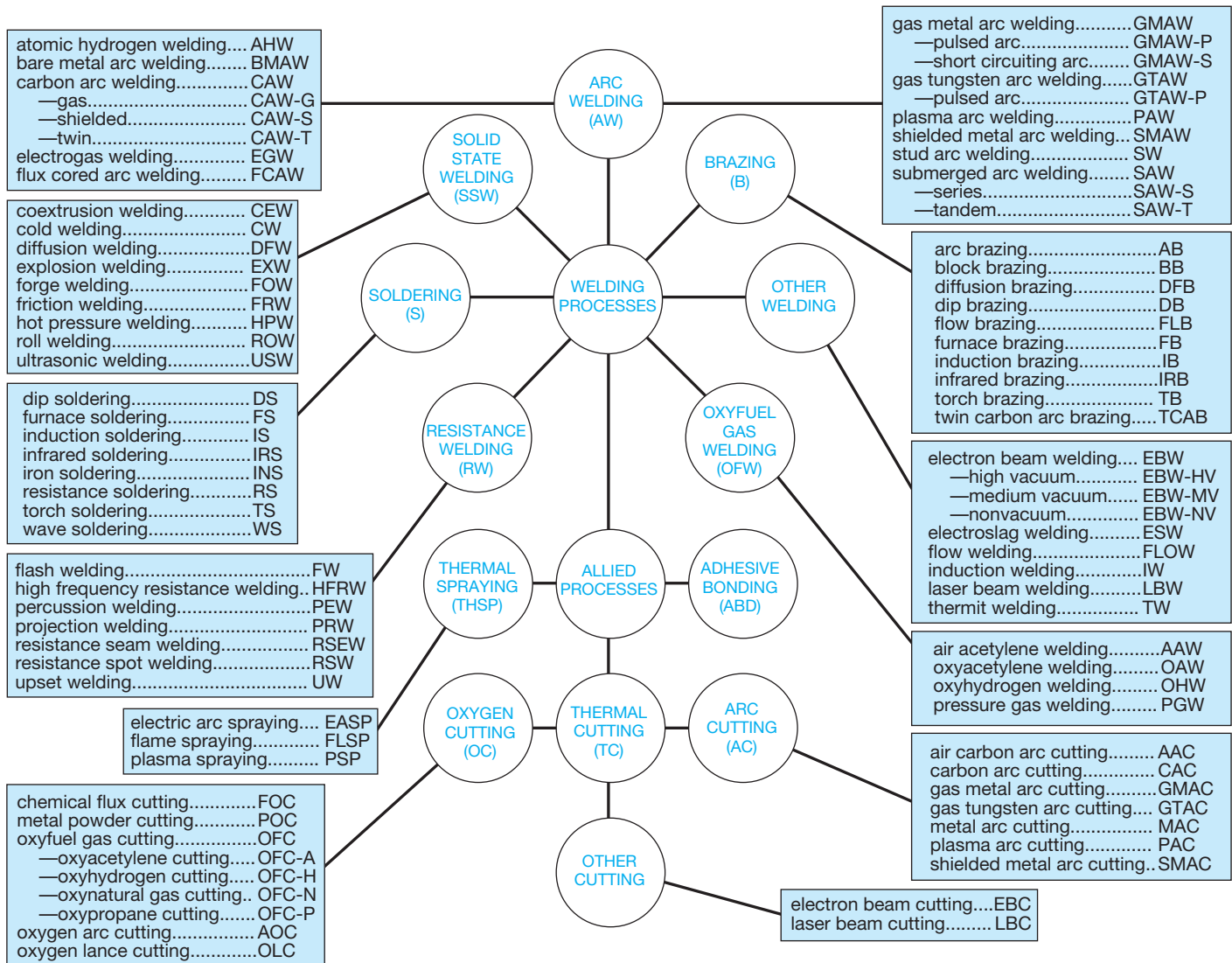


FIGURE 18.3 Master chart of welding and allied processes. Courtesy American Welding Society

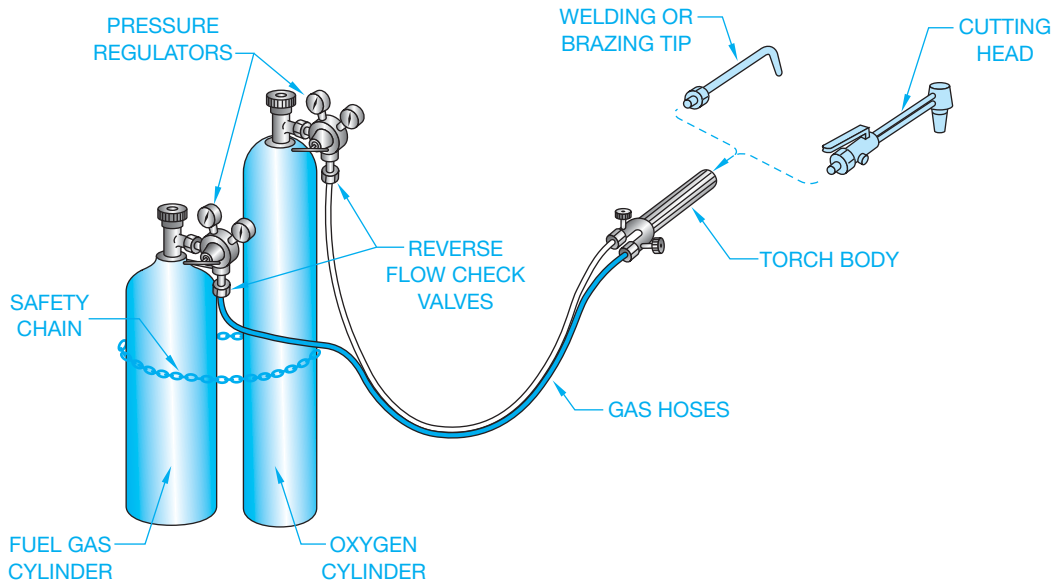


FIGURE 18.4 Oxyfuel welding and cutting equipment.

© Cengage Learning 2012

two very closely fitting metals by heating the pieces, causing the filler metal to be drawn into the joint by capillary action. **Braze welding** is more of a joint filling process that does not rely on capillary action. Another process that uses an oxyfuel mixture is **flame cutting**. This process uses a high-temperature gas flame to preheat the metal to a kindling temperature, at which time a stream of pure oxygen is injected to cause the cutting action.

## Shielded Metal Arc Welding

**Shielded metal arc or stick electrode welding** is the most traditionally used welding method. High-quality welds on a variety of metals and thicknesses can be made rapidly with excellent uniformity. This method uses a flux-covered metal electrode to carry an electrical current forming an arc that melts the work and the electrode. The molten metal from the electrode mixes with the melting base material, forming the weld. Shielded metal arc welding is popular because of low-cost equipment

and supplies, flexibility, portability, and versatility. Figure 18.5 shows a shielded metal arc welding setup.

## Gas Tungsten Arc Welding

The **gas tungsten arc welding** process is sometimes referred to as **tungsten inert gas welding (TIG)**, or as **Heliarc®**, which is a trademark of the Union Carbide Corporation. Gas tungsten arc welding can be performed on a wider variety of materials than shielded metal arc welding, and it produces clean, high-quality welds. This welding process is useful for certain materials and applications. Gas tungsten arc welding is generally limited to thin materials, high-integrity joints, or small parts, because of its slow welding speed and high cost of equipment and materials (see Figure 18.6).

## Gas Metal Arc Welding

Another welding process that is extremely fast, economical, and produces a very clean weld is **gas metal arc welding**.

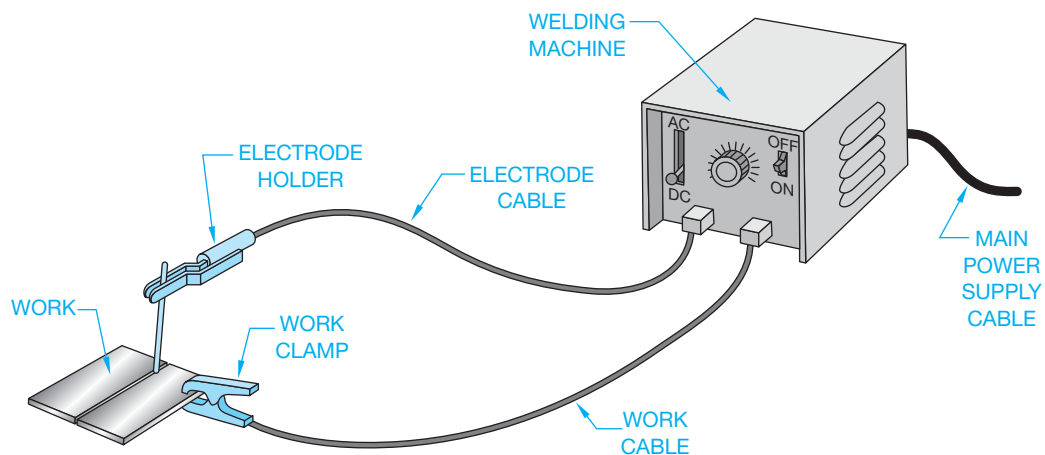


FIGURE 18.5 Shielded metal arc welding equipment.

© Cengage Learning 2012

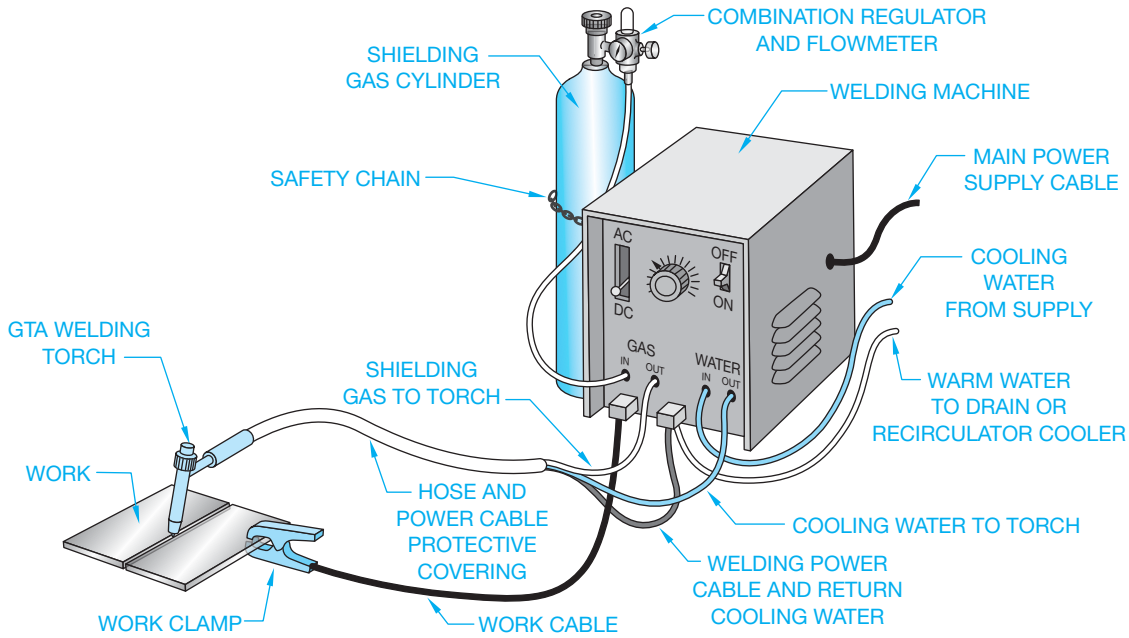


FIGURE 18.6 Gas tungsten arc welding equipment.

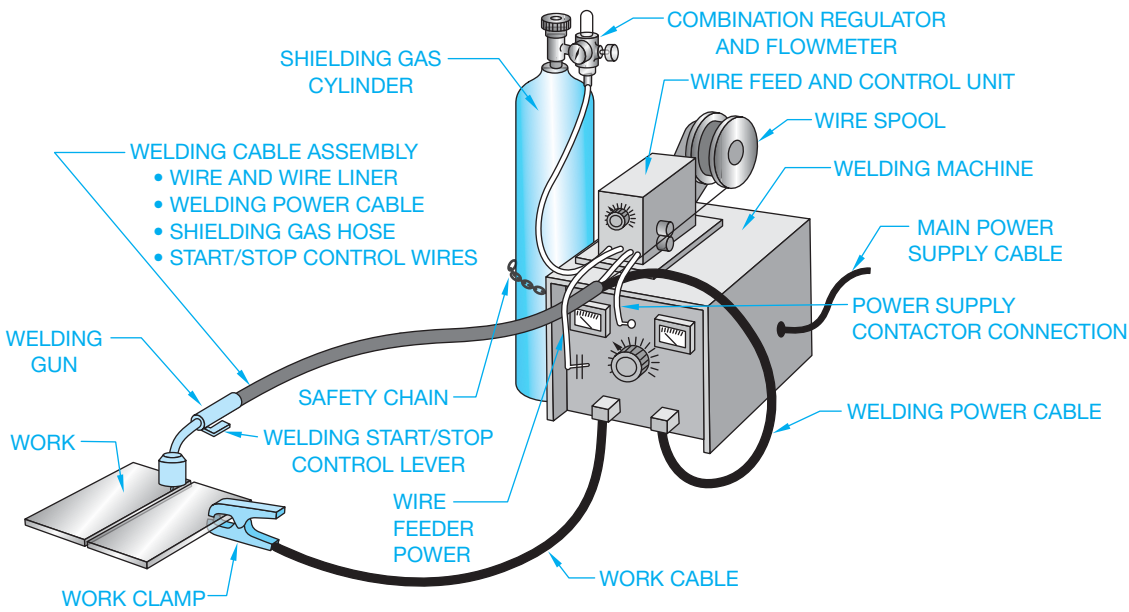


FIGURE 18.7 Gas metal arc welding equipment.

This process may be used to weld thin material or heavy plate. It was originally used for welding aluminum using a metal inert gas shield, a process that was referred to as MIG. The application now employs a current-carrying wire that is fed into a joint between pieces to form the weld. This welding process is used in industry with automatic or robotic welding machines to produce rapidly made, high-quality welds in any welding position. Although the capital expense of the equipment remains high, the cost is declining because of its popularity. Figure 18.7 shows gas metal arc welding equipment.

## ELEMENTS OF WELDING DRAWINGS

### STANDARDS

**ANSI/ASME** The standard related to drafting practices covered in this chapter is AWS A2.4, *Standard Symbols for Welding, Brazing, and Nondestructive Examination*. This American Welding Society (AWS) standard is developed in accordance with the rules of the American National Standards Institute (ANSI) and published by the American Welding Society.

Welding drawings are made up of several parts to be welded together. These drawings are usually called **weldments**, **welding assemblies**, or **subassemblies**. The welding assembly typically shows the parts together in multiview with all of the fabrication dimensions, types of joints, and weld symbols. **Welding symbols** identify the location of the weld, the welding process, the size and length of the weld, and other **weld information**. The **weld symbol** indicates the type of weld and is part of the welding symbol. The **welding assembly** has a list of materials that generally provides a key to the assembly, the number of each part, part size, and material. Figure 18.8 shows a welding subassembly. When additional component parts must be specified, then detailed drawings of each part are prepared, as shown in Figure 18.9.

### Welding and Weld Symbols

There are a few basic components of a welding symbol, beginning with the reference line, tail, and leader, which are drawn as thin lines as shown in Figure 18.10. The reference line is usually the first welding symbol element to be located on the

drawing. The reference line leader is drawn using the same rules associated with leaders for notes. The leader can be drawn at any angle, although angles less than 15° or greater than 75° should be avoided. Also, leaders for notes typically run from the shoulder directly to the feature. This practice should be used for welding leaders, although sometimes welding leaders bend to point into difficult-to-reach places, or with more than one leader extending from the same reference line, as shown in Figure 18.11. This practice is not allowed when drawing ASME standard dimensioning leaders.

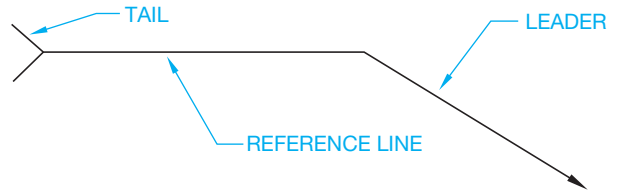


FIGURE 18.10 Welding symbols: reference line, tail, and leader.

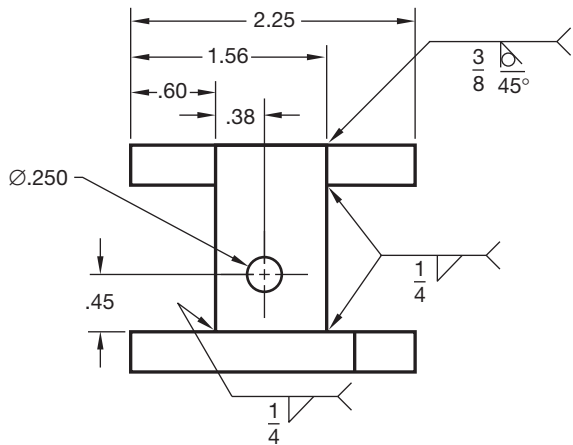


FIGURE 18.8 Welded subassembly.

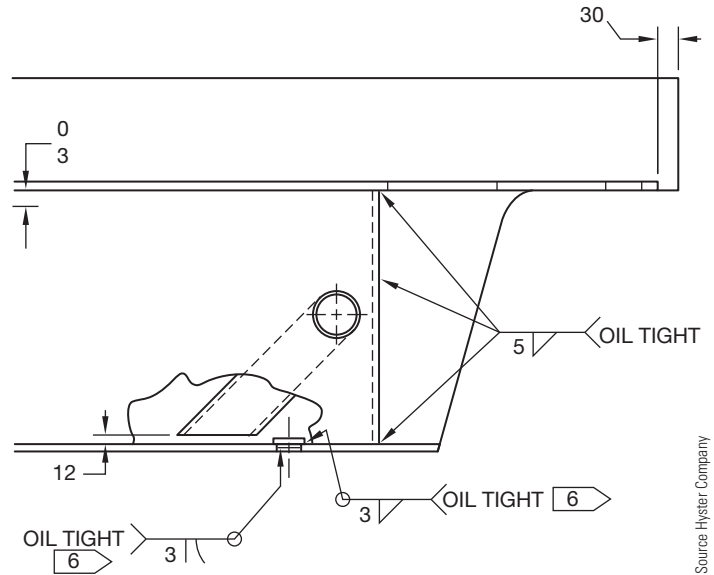


FIGURE 18.11 Welding symbol leader use.

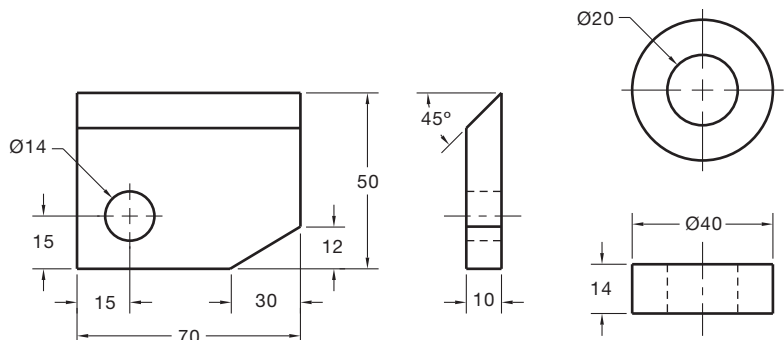
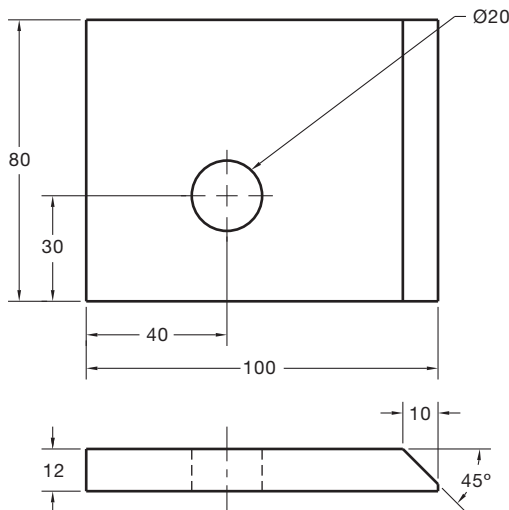
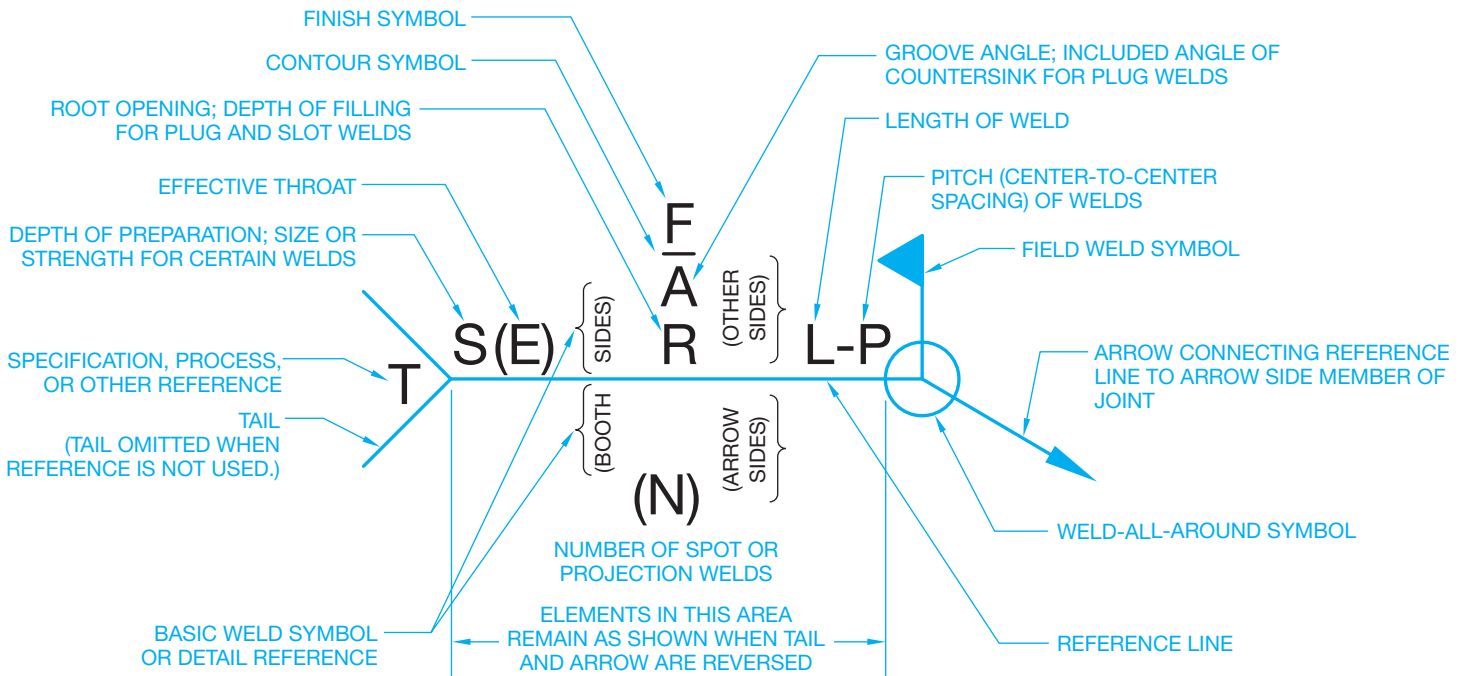


FIGURE 18.9 Drawings of each part of the welded subassembly.



LOCATION OF WELDS		
ARROW SIDE OF JOINT	OTHER SIDE OF JOINT	BOTH SIDES OF JOINT
<p>1. THE SIDE OF THE JOINT TO WHICH THE ARROW POINTS IS THE ARROW SIDE.                  2. BOTH-SIDES WELDS OF SAME TYPE ARE OF SAME SIZE UNLESS OTHERWISE SHOWN.                  3. SYMBOLS APPLY BETWEEN ABRUPT CHANGES IN DIRECTION OF JOINT OR AS DIMENSIONED (EXCEPT WHERE ALL AROUND SYMBOL IS USED).                  4. ALL WELDS ARE CONTINUOUS AND OF USER'S STANDARD PROPORTIONS, UNLESS OTHERWISE SHOWN.                  5. TAIL OF ARROW USED FOR SPECIFICATION REFERENCE. (TAIL MAY BE OMITTED WHEN REFERENCE NOT USED.)                  6. DIMENSIONS OF WELD SIZES, INCREMENT LENGTHS, AND SPACING IN INCHES.</p> <p>WELDING SYMBOL TEXT: .12 IN, (3 mm) MINIMUM, OFFSET TEXT .06 IN (1.5 mm) MINIMUM FROM THE REFERENCE LINE. WELD SYMBOL AND TEXT SHOULD BE PLACED RELATED TO THE REFERENCE LINE AS SHOWN IN THE EXAMPLES THROUGHOUT THIS CHAPTER.</p>		

FIGURE 18.12 Standard location of elements of a welding symbol. Courtesy American Welding Society

After the reference line has been established, additional information is placed on the reference line to continue the weld specification. Figure 18.12 shows the standard location of welding symbol elements as related to the reference line, tail, and leader. As previously introduced, the weld symbol indicates the type of weld and is part of the welding symbol. Weld symbols are generally drawn on or near the center of the reference line of the welding symbol. Typical weld symbols are shown in Figure 18.13.

### Supplementary Symbols

Supplementary symbols shown in Figure 18.14 are used with welding symbols to identify weld features such as how and where the weld is placed.

### Welding Symbol Placement

The arrowhead of the welding symbol leader points to the desired weld location in the view that best shows the weld location as object lines. Drawing a welding symbol arrow to a hidden feature is acceptable if necessary.

FILLET	SQUARE	SCARF	V	BEVEL	U	J	FLARE-V	FLARE-BEVEL
PLUG OR SLOT	EDGE FLANGE	CORNER FLANGE	STUD	SURFACING	SPOT OR PROJECTION	SEAM	BACK OR BACKING	

FIGURE 18.13 Typical weld symbols. © Cengage Learning 2012

WELD ALL AROUND	FIELD WELD	MELT THROUGH	CONSUMABLE INSERT (SQUARE)	BACKING OR SPACER (RECTANGLE)	FLUSH OR FLAT CONTOUR	CONVEX CONTOUR	CONCAVE CONTOUR

FIGURE 18.14 Supplementary welding symbols. © Cengage Learning 2012

### U.S. Customary and Metric Units

Welding symbols and their components are created using the same units as the drawing on which they are displayed. For example, if the drawing is created using inch units, then the welding symbols are drawn in inches. When the drawing is created using metric units, the welding symbols are drawn in millimeters.

### STANDARDS

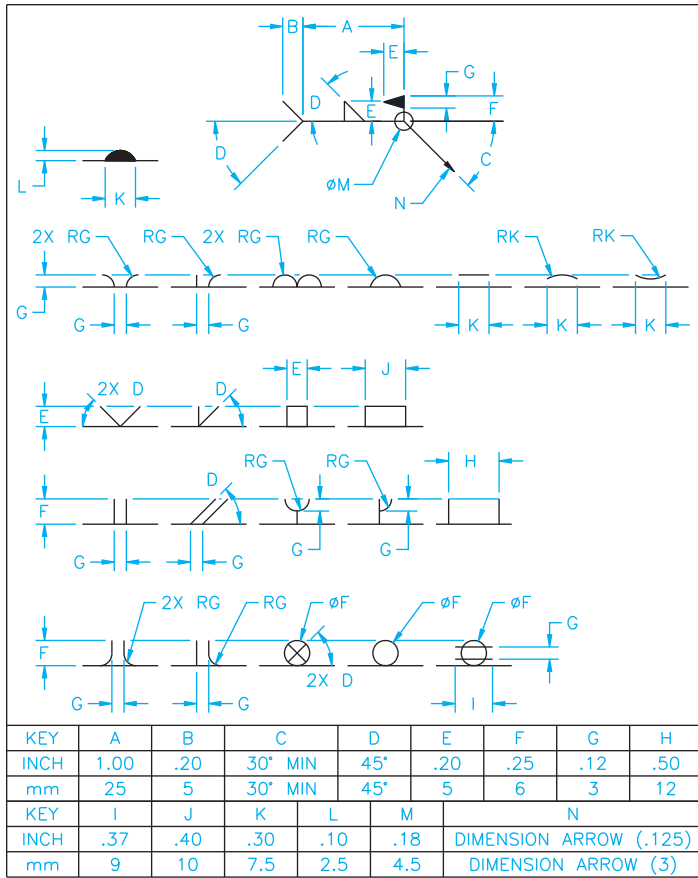
**Welding and Weld Symbol Sizes** AWS A2.4 provides inch and metric values in millimeters for use when drawing weld and welding symbols, as shown in Figure 18.15. Use these recommended sizes when creating your manual drawings or for designing a welding computer-aided design and drafting (CADD) symbol library. Welding symbol templates are also available for manual drafting practices.

### TYPES OF WELDS

The following information relates types of welds to their weld symbol. The weld symbol is normally the next item you place on the welding symbol. The type of weld is associated with one or more of the following: the weld symbol, weld shape, and type of groove to which the weld is applied. Figures 18.13, 18.14, and 18.15 show the information that is associated with the types of welds.

#### Fillet Weld

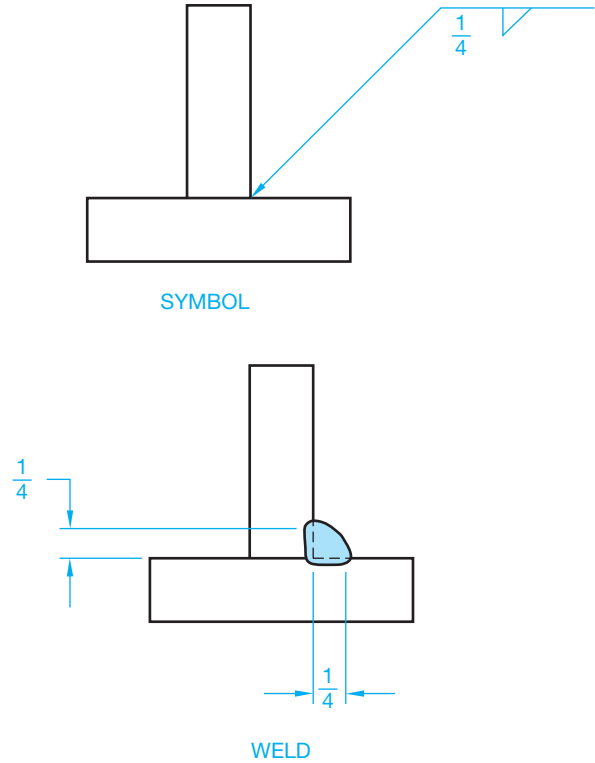
A **fillet weld** is formed in the internal corner of the angle formed by two pieces of metal. A fillet weld joins two edges at right angles. The cross section of a fillet weld is an approximate right triangle. The sides of the right triangle are the **legs**. The size of the fillet weld is shown on the same side of the reference line as the weld symbol and to the left of the symbol. When both legs



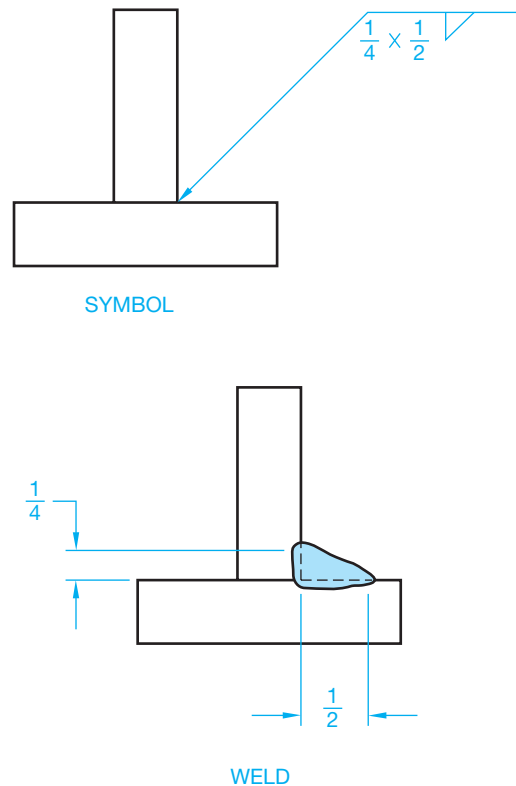
**FIGURE 18.15** Specification for drafting welding symbols. The horizontal line segment on which each of the weld or supplementary symbols rests is the related portion of the reference line. The letters on the drawing match specific inch and metric values in the chart. © Cengage Learning 2012

of the fillet weld are the same, the size is given once as shown in Figure 18.16. When the leg lengths are different in size, the vertical dimension is followed by the horizontal dimension (see Figure 18.17). Recommended minimum sizes for prequalified fillet welds are shown in the following table: Prequalified welds are most of the common welded joints used in steel construction and are exempt from tests and qualification.

MINIMUM PREQUALIFIED FILLET WELD SIZE	
Base Material Thickness of the Thinner Part Joined (T)	Minimum Size of Fillet Weld
T less than or equal to 1/4 IN (6 mm)	1/8 IN (3 mm)
T greater than 1/4 IN and less than or equal to 1/2 IN (12 mm)	3/16 IN (5 mm)
T greater than 1/2 IN and less than or equal to 3/4 IN (19 mm)	1/4 IN (6 mm)
T greater than 3/4 IN	5/16 IN (8 mm)



**FIGURE 18.16** Fillet weld with equal legs. Dimension values in this figure are in inches.



**FIGURE 18.17** Fillet weld with different leg lengths. Dimension values in this figure are in inches.

## Introduction to Groove Welds

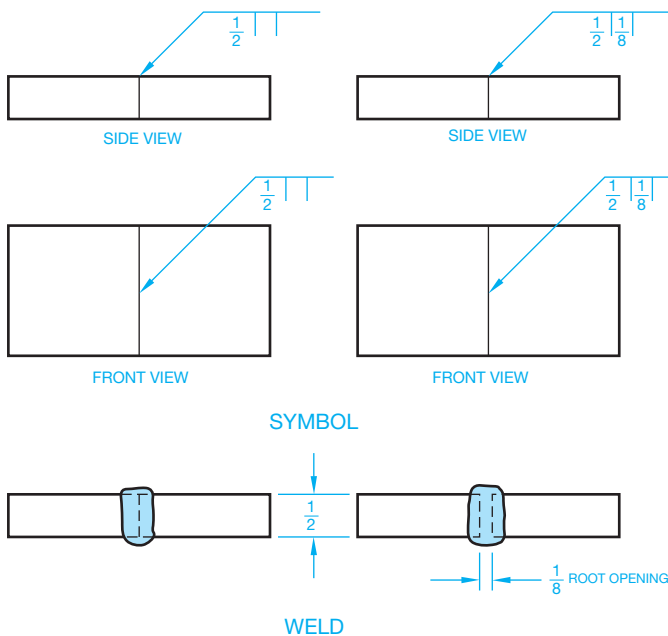
**Groove welds** are commonly used to make edge-to-edge joints. Groove welds are also used in corner joints, T joints, and joints between curved and flat pieces. There are several types of groove welds described in the following. The differences between groove welds depend on the parts to be joined and the preparation of their edges. When creating a groove weld, weld metal is deposited within the groove and weld penetration fuses with the base metal to form the joint. The selection of specific welds is based on the weld groove design, and the material thickness is an engineering application that requires stress analysis and calculations that are beyond the scope of this textbook. When working in a fabrication industry, the engineer will provide the information and specifications needed for you to accurately draw the welding symbols.

### Square Groove Weld

A **square groove weld** is applied to a butt joint between two pieces of metal. The two pieces of metal are spaced apart a given distance known as the **root opening**. If the root opening distance is a standard in the company, then this dimension is assumed. If the root opening is not standard, then the specified dimension is given inside of the square groove symbol, as shown in Figure 18.18.

### V Groove Weld

A **V groove weld** is formed between two adjacent parts when the side of each part is beveled to form a groove between the parts in the shape of a V. The included angle of the V can be given with or without a root opening as shown in Figure 18.19.

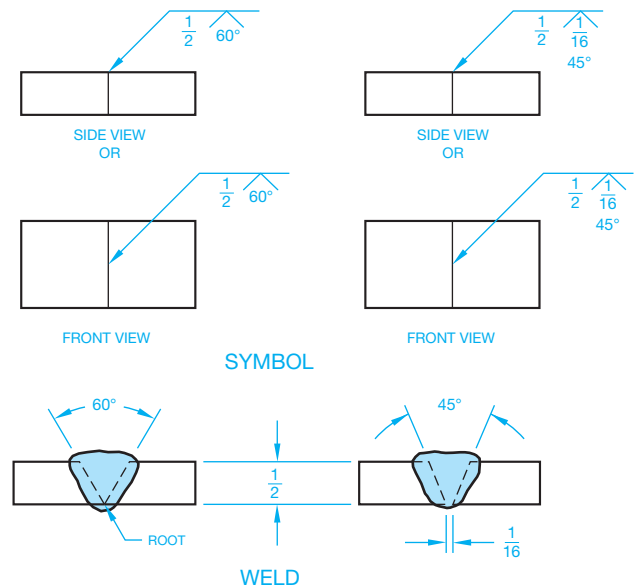


**FIGURE 18.18** Square groove weld showing the root opening. Dimension values in this figure are in inches. © Cengage Learning 2012

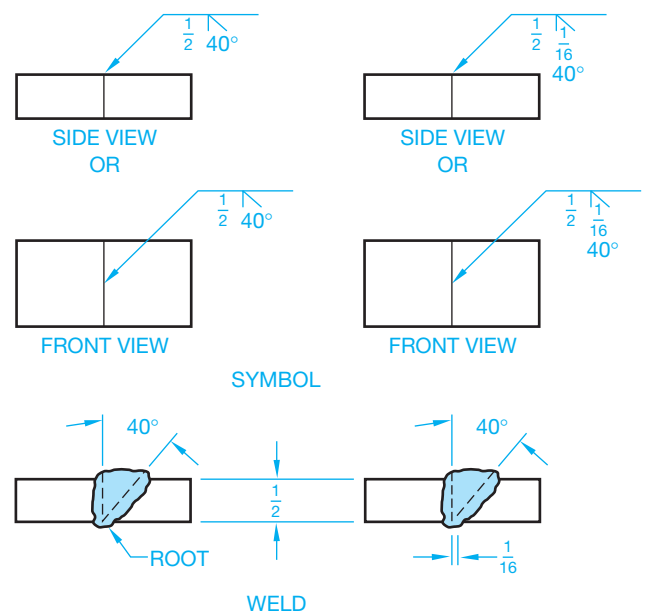
A **flare-V groove weld** is commonly used to join two rounded or curved parts (see Figure 18.35). The intended depth of the weld itself is given to the left of the symbol, with the weld depth shown in parentheses.

### Bevel Groove Weld

The **bevel groove weld** is created when one piece is square and the other piece has a beveled surface. The bevel weld can be given with a bevel angle and a root opening, as shown in Figure 18.20. A **flare-bevel groove weld** is commonly used to



**FIGURE 18.19** V groove weld. Dimension values in this figure are in inches.



**FIGURE 18.20** Bevel groove weld. Dimension values in this figure are in inches.



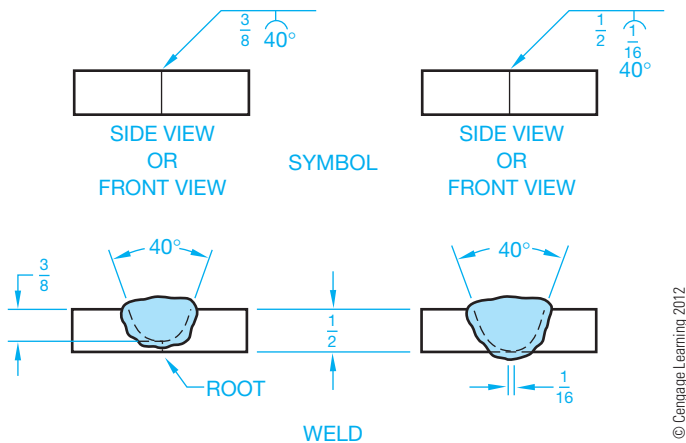


FIGURE 18.21 U groove weld. Dimension values in this figure are in inches.

join flat parts to rounded or curved parts (look ahead to Figure 18.35). The intended depth of the weld itself is given to the left of the symbol, with the weld depth shown in parentheses.

## U Groove Weld

A **U groove weld** is created when the groove between two parts is in the form of a U. The angle formed by the sides of the U shape, the root, and the weld size are generally given (see Figure 18.21).

## J Groove Weld

The **J groove weld** is necessary when one piece is a square cut and the other piece is in a J-shaped groove. The included angle, the root opening, and the weld size are given, as shown in Figure 18.22.

## Plug Weld

A **plug weld** is made in a hole in one piece of metal that is lapped over another piece of metal. These welds are specified by giving the weld size, angle, depth, and pitch (see Figure 18.23a). The same type of weld can be applied to a slot. This is referred to as a **slot weld** as shown in Figure 18.23b.

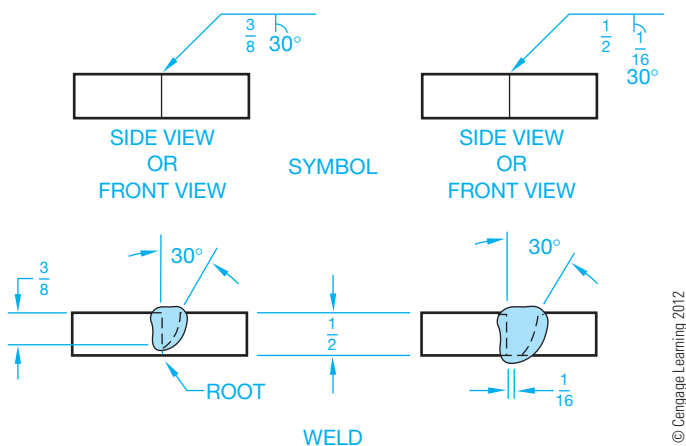


FIGURE 18.22 J groove weld. Dimension values in this figure are in inches.

## Flush Contour Weld

Generally, the surface contour of a weld is raised above the surface face. If this is undesirable, then a flush surface symbol must be applied to the weld symbol. When the **flush contour weld** symbol is applied without any further consideration, the welder must perform this effect without any finishing. The other option is to specify a flush finish using another process. The letter designating the other process is placed above the flush contour symbol for another side application or below the flush contour symbol for an arrow side application. The options include C = chipping, G = grinding, M = machining, R = rolling, and H = hammering (see Figure 18.24).

## Spot Weld

**Spot welding** is a process of resistance welding in which the base materials are clamped between two electrodes and a momentary electric current produces the heat for welding at the contact spot. Spot welding is generally associated with welding sheet metal lap seams. The size of the spot weld is given as a diameter to the left of the symbol. The center-to-center pitch is given to the right of the symbol (see Figure 18.25). The strength of the spot welds can be given as minimum shear strength in pounds per spot to the left of the symbol, as shown in Figure 18.26a. When a specific number of spot welds is required in a seam or joint, the quantity is placed above or below the symbol in parentheses, as shown in Figure 18.26b.

## Seam Weld

A **seam weld** is another type of resistance weld that is a continuous weld made between or on overlapping members. The continuous weld can consist of a single weld bead or a series of overlapping spot welds. The dimensions of seam welds, shown on the same side of the reference line as the weld symbol, relate to either size or strength. The weld size width is shown to the left of the symbol in fractional or decimal inches, or millimeters (see Figure 18.27a.) The weld length, when specified, is provided to the right of the symbol, as shown in Figure 18.27b. The strength of a seam weld is expressed as minimum acceptable shear strength in pounds per linear inch, placed to the left of the weld symbol, as shown in Figure 18.28.

## Flange Welds

**Flange welds** are used on light-gage metal joints where the edges to be joined are flanged or flared. Dimensions of flange welds are placed to the left of the weld symbol. Further, the radius and height of the weld above the point of tangency are indicated by showing both the radius and the height separated by a plus (+) symbol. The size of the flange weld is then placed outward of the flange dimensions (see Figure 18.29).

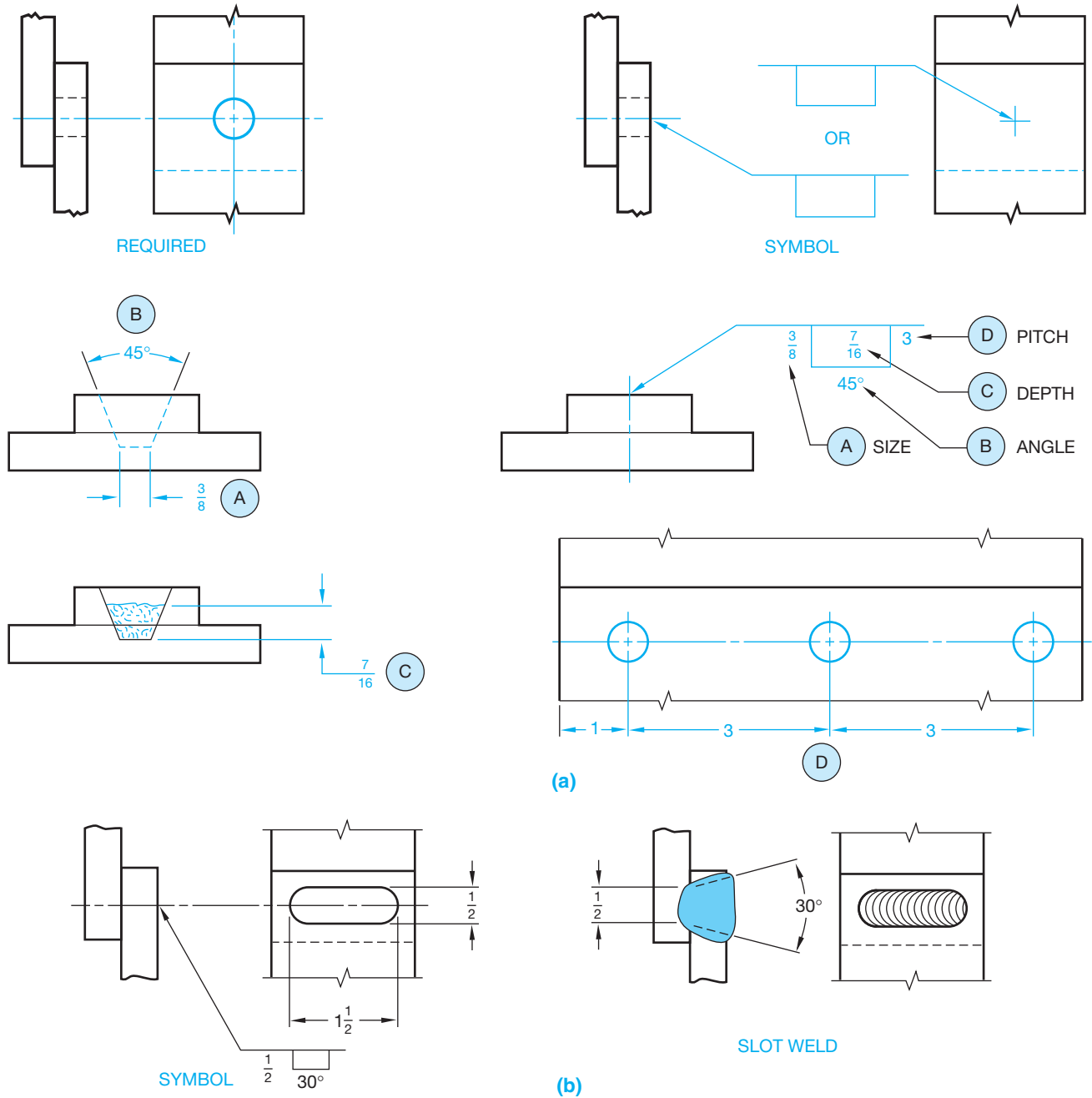


FIGURE 18.23 (a) Plug weld. (b) Slot weld. Dimension values in this figure are in inches.

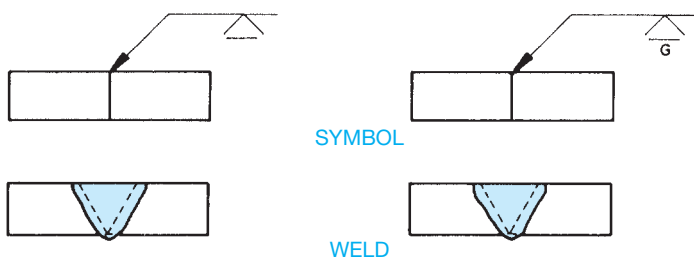


FIGURE 18.24 Flush contour weld. Dimension values in this figure are in inches. © Cengage Learning 2012

### WELD SYMBOL LEADER ARROW RELATED TO WELD LOCATION

Welding symbols are applied to the joint as the basic reference for the welding process used. All joints have an **arrow side** and **other side**. When fillet and groove welds are used, the welding symbol leader arrows connect the symbol reference line to one side of the joint known as the *arrow side*. The side opposite the location of the arrow is called the *other side*. If the weld is to be deposited on the arrow side of the joint, then the proper weld symbol is placed *below* the reference line as shown

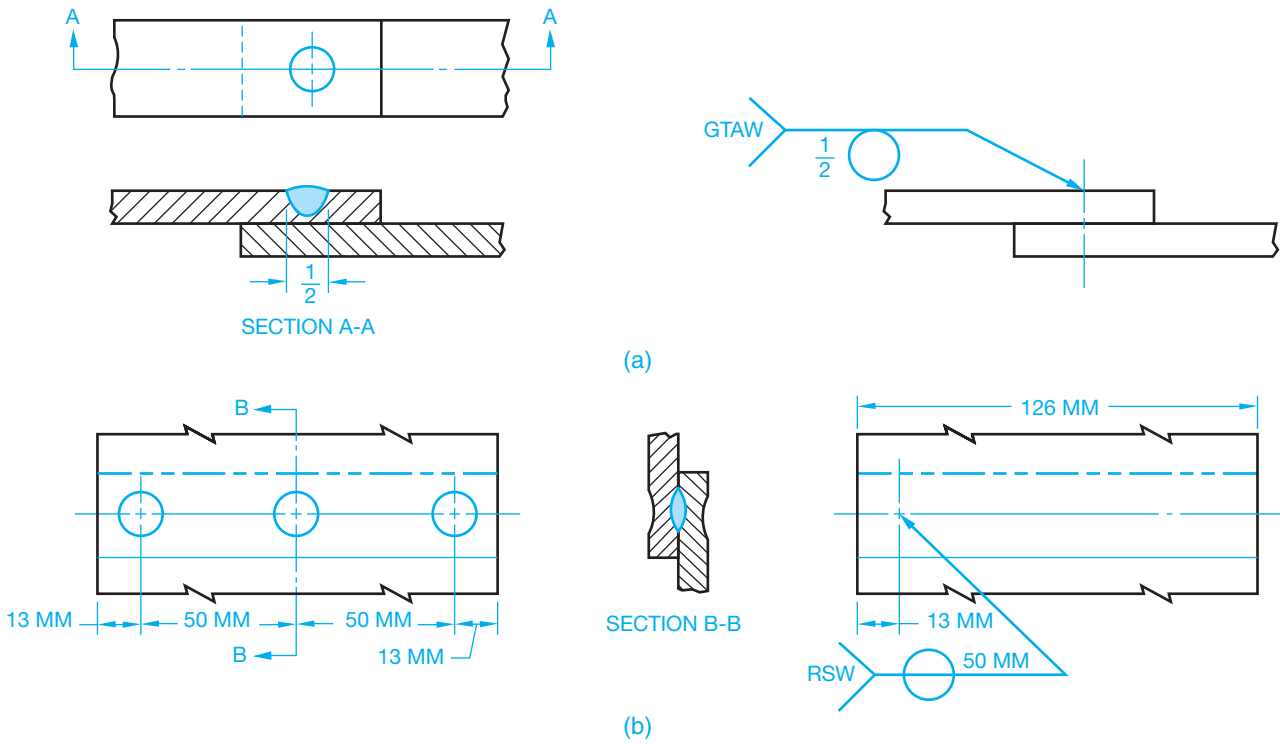


FIGURE 18.25 Designating spot welds.

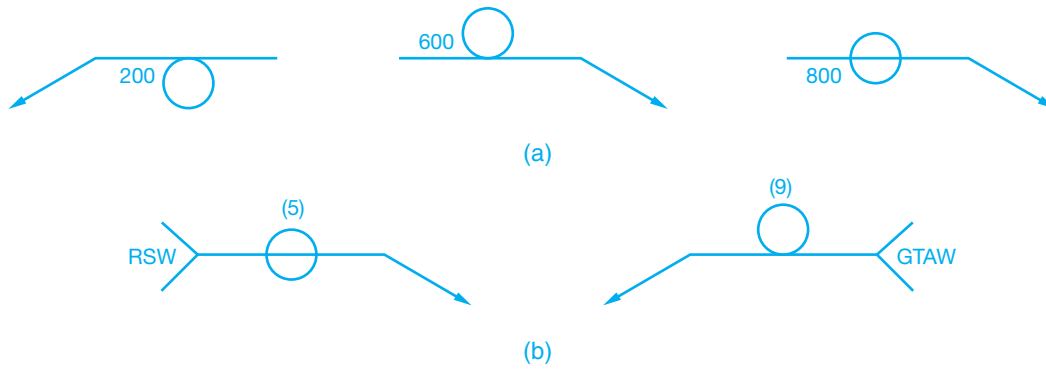


FIGURE 18.26 Designating strength and number of spot welds.

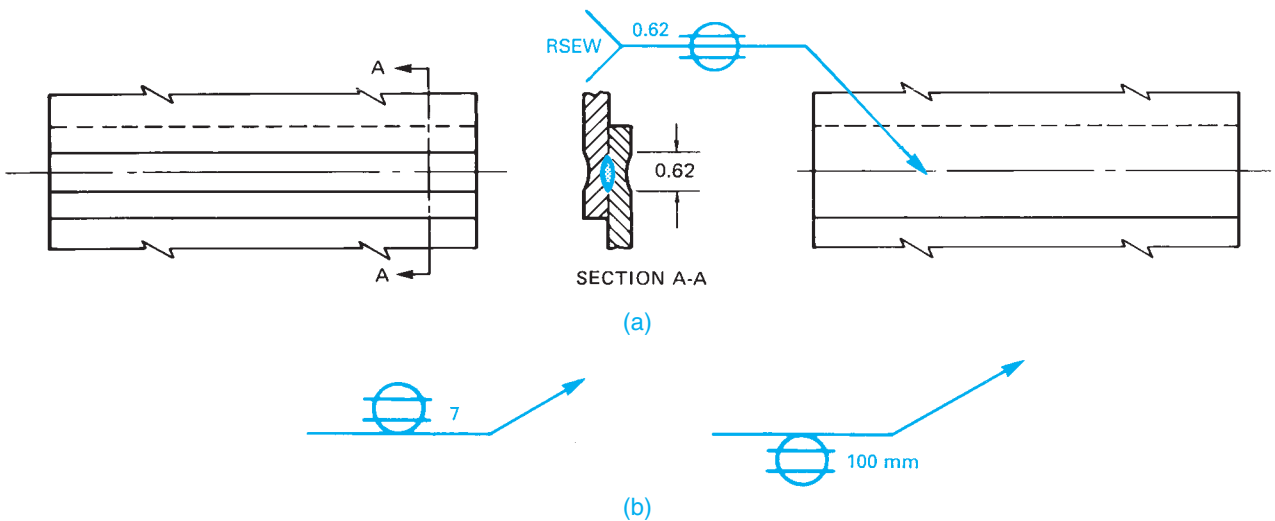
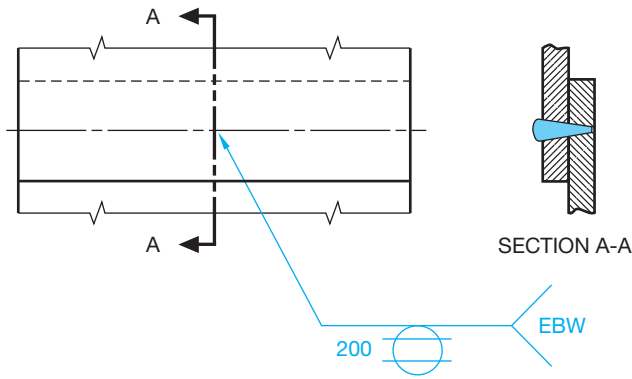


FIGURE 18.27 Indicating the length of a seam weld.



© Cengage Learning 2012

FIGURE 18.28 Indicating the strength of a seam weld.

in Figure 18.30a. If the weld is to be deposited on the side of the joint opposite the arrow, then the weld symbol is placed *above* the reference line as shown in Figure 18.30b. The same weld symbol is shown *above and below* the reference line when welds are to be deposited on both sides of the joint as shown in Figures 18.30c and d.

For plug, spot, seam, or resistance welding symbols, the leader arrow connects the welding symbol reference line to the

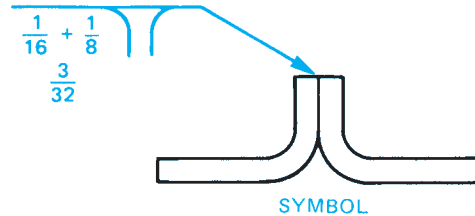
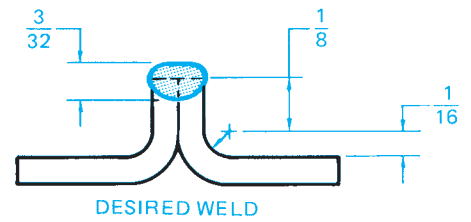


FIGURE 18.29 Applying dimensions to flange welds. Dimension values in this figure are in inches.

outer surface of one of the members of the joint at the center line of the desired weld. The member that the arrow points to is considered the arrow side member. The member opposite of the arrow is considered the other side member.

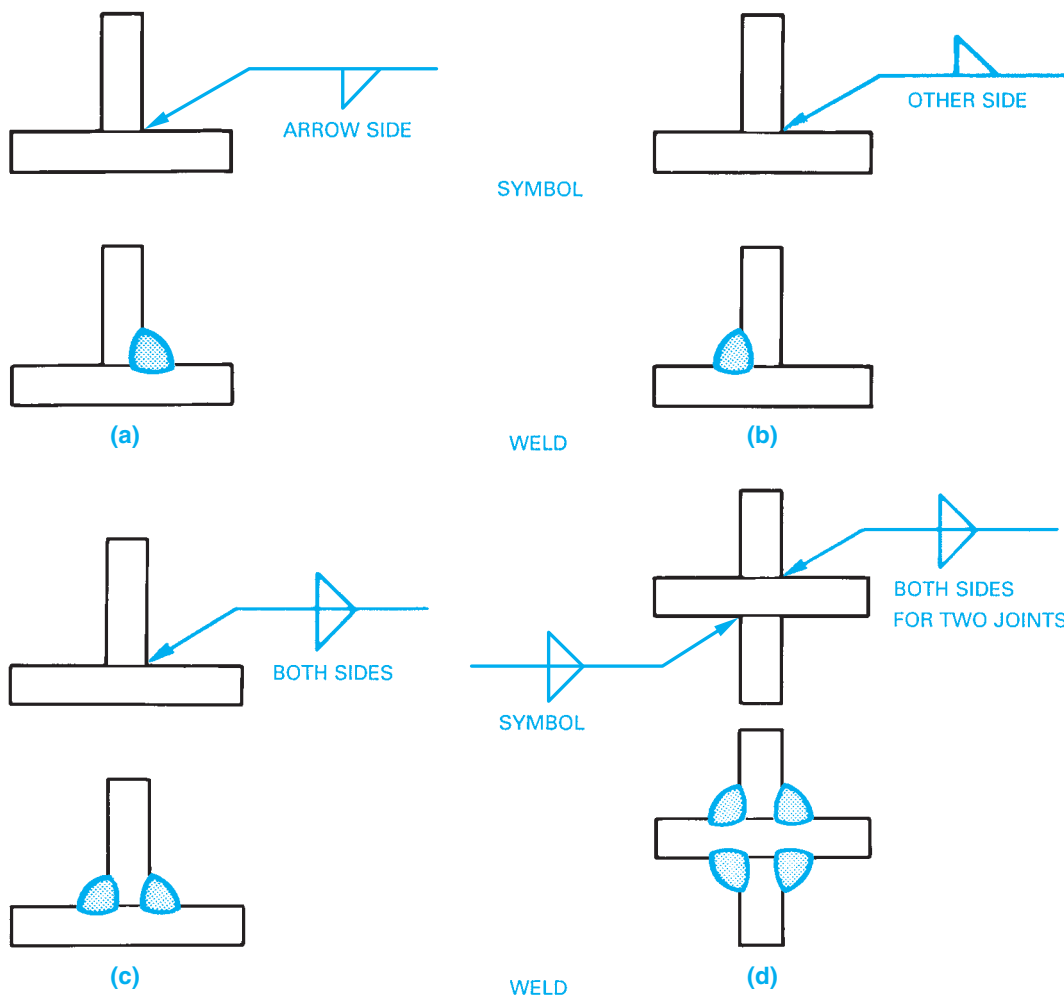


FIGURE 18.30 Designing weld locations. (a) Arrow side weld. (b) Other side weld. (c) Both sides weld. (d) Both sides for two joint welds.

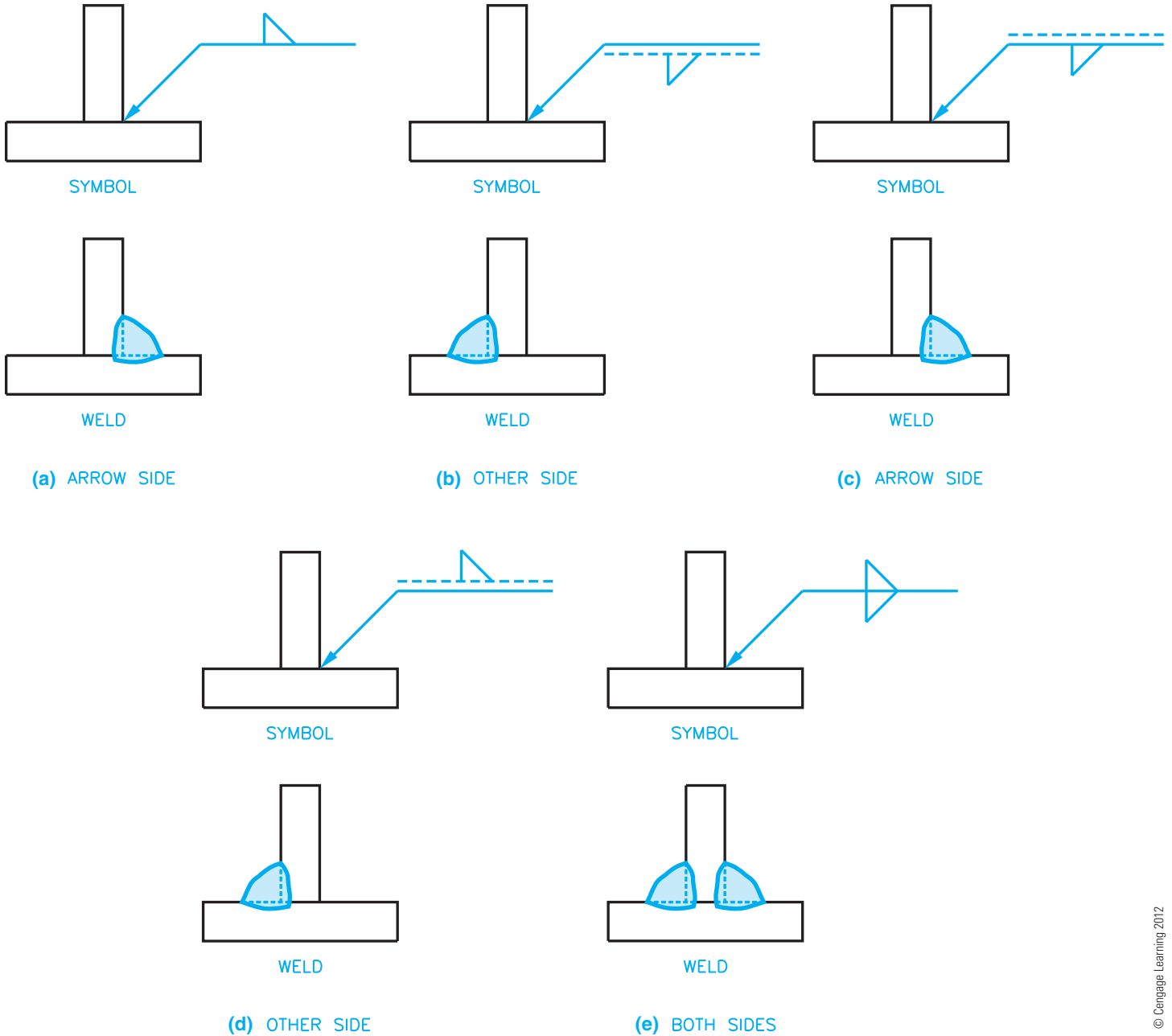
### Metric Reference Line Application Related to Weld Location

Metric welding symbol practices such as those used in the British Standard include a dashed line next to the solid reference line for certain applications. Weld symbols drawn on the solid reference line relate to welds on the arrow side of the item being welded. Use caution when comparing this method to the AWS standard, because there are differences that can cause confusion. Weld symbols on the dashed line relate to a weld on the other side of the item. If the dashed line is above the solid

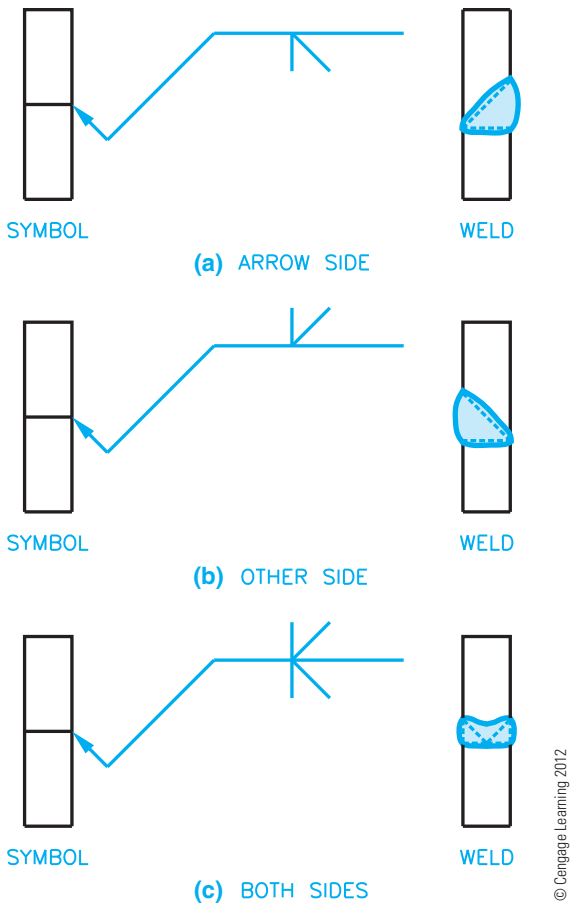
line, then the symbol for the arrow side weld is drawn below the solid reference line and the symbol for the other side weld is above the dashed line. Figure 18.31 shows this application. The dashed line is omitted if the welds are symmetrical on both sides of the item being welded.

### Drawing a Break in the Welding Symbol Leader

When two parts meet and a bevel, J groove, or flange is used, you can direct the groove to be placed on only one of the pieces.

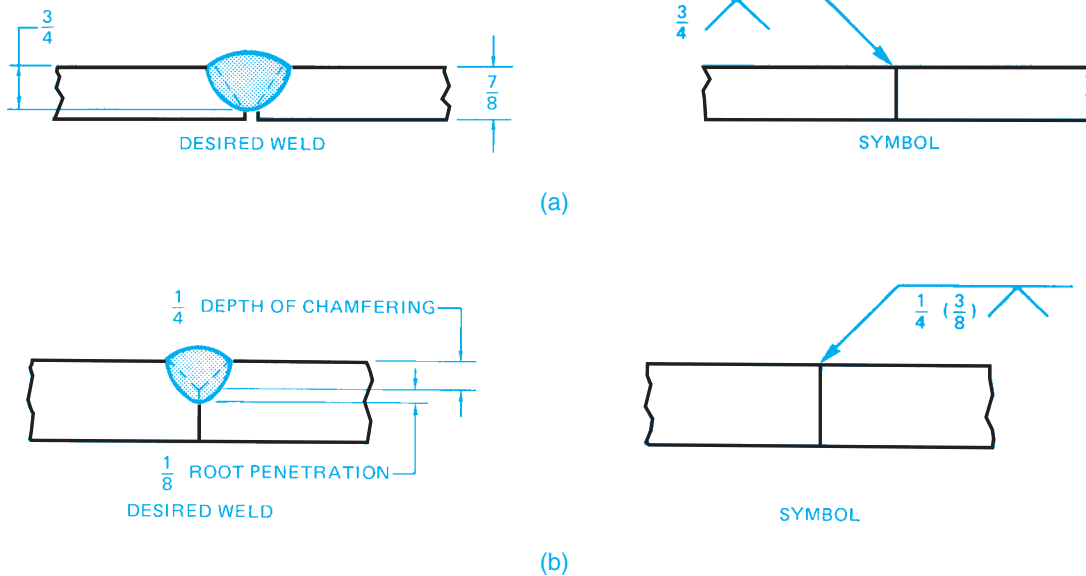


**FIGURE 18.31** Metric welding symbol practices such as those used in the British Standard include a dashed line next to the solid reference line. (a) A weld symbol drawn on the solid reference line related to a weld on the arrow side of the item being welded. (b) A weld symbol on the dashed line relates to a weld symbol on the far side of the item. (c) If the dashed line is above the solid line, then the symbol for the nearside weld is drawn below the solid reference line. (d) If the dashed line is above the solid line, then the symbol for the far side weld is above the dashed line. (e) The dashed line is omitted if the welds are symmetrical on both sides of the item being welded.



**FIGURE 18.32** Using a jog or bend in the leader line to designate the part where you want the groove to be placed. (a) Arrow side weld. (b) Other side weld. (c) Both sides.

To do this, draw a jog or bend in the leader line and point the leader to the part where you want the groove placed. The other part has no groove as shown in Figure 18.32.



**FIGURE 18.33** (a) Designating the size of grooved welds with partial penetration. (b) Showing size and penetration of grooved welds. Dimension values in this figure are in inches.

## ADDITIONAL WELD CHARACTERISTICS

Additional weld characteristics can be added to the welding symbol, including field weld, weld penetration, melt through, weld all around, and weld length.

### Field Weld

A **field weld** is a weld that is performed on the job site, which is referred to as the *field*, rather than in a fabrication shop. The reason for this application can be that the individual components are easier to transport disassembled or that the mounting procedure requires job-site installation. The field weld symbol is a flag attached to the reference line at the leader intersection as shown in Figures 18.12, 18.14, and 18.15. The field weld symbol can be above or below the reference line, and the flag always points in the direction of the reference line.

### Weld Penetration

Unless otherwise specified, a weld penetrates through the thickness of the parts at the joint. The size of the groove weld remains to the left of the weld symbol. Figure 18.33a shows the size of grooved welds with partial penetration. Notice in Figure 18.33b that a weld with partial penetration can specify the depth of the groove followed by the depth of weld penetration in parentheses, with both items placed to the left of the weld symbol.

The weld size can be omitted when single-groove and symmetrical double-groove welds penetrate completely through the parts being joined as shown in Figure 18.34. The depth of penetration of flare-formed groove welds is assumed to extend to the tangent points of the members as shown in Figure 18.35.

### Melt Through

**Melt through** is a term that refers to the weld melting through the bottom of the weld or the opposite side of where the weld

Courtesy American Welding Society

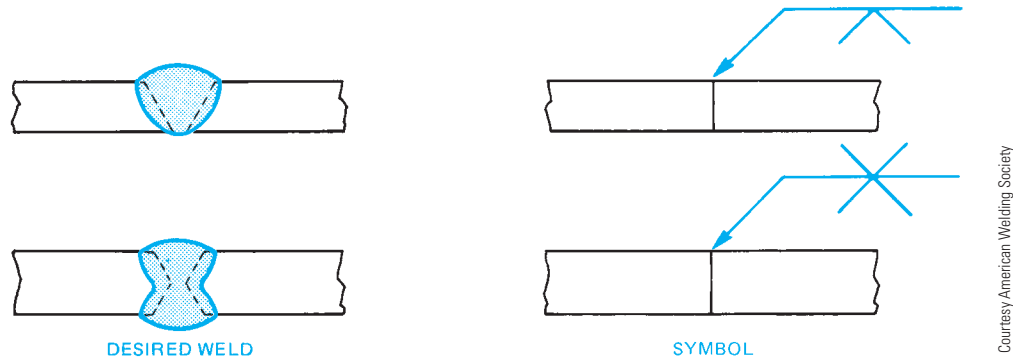


FIGURE 18.34 Designating single- and double-groove welds with complete penetration.

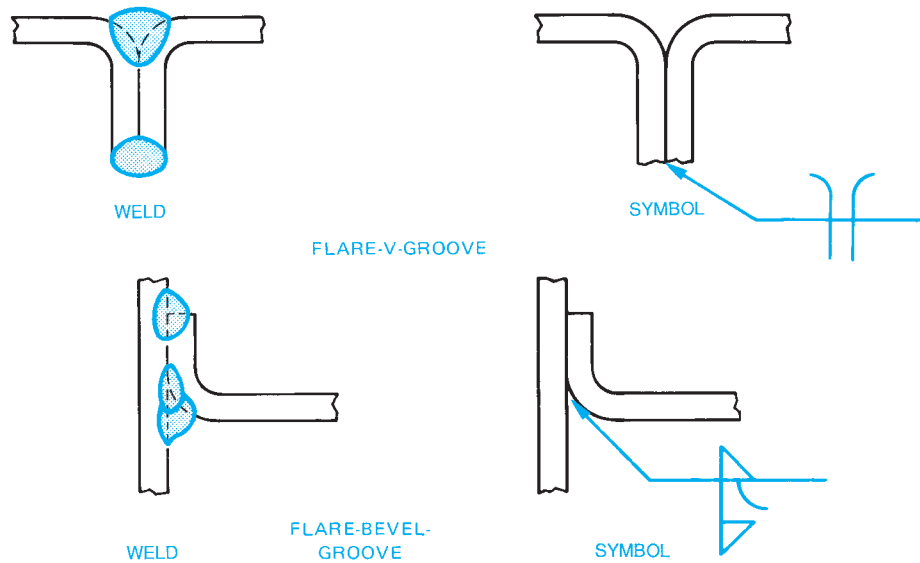


FIGURE 18.35 Designating flare-V and flare-bevel-groove welds.

is being applied. When improperly done or when not specified, melt through can be unacceptable. However, melt through is desired when the symbol shown in Figure 18.36 is used. The melt-through symbol is placed on the side of the reference line opposite the weld symbol. Melt through is used only when complete joint penetration and visible root reinforcement is required in welds made from one side. The desired melt-through distance can be placed to the left of the melt-through symbol on the reference line (see Figure 18.36).

### Weld All Around

When a welded connection must be performed all around a feature, the **weld-all-around** symbol is attached to the reference line at the junction of the leader (see Figure 18.37).

### Weld Length and Pitch

The **weld length** should be given when a weld is not continuous along the length of a part. The weld length is the length of a weld that is not continuous. In some situations, the weld along the length of a feature is given in lengths spaced a given distance apart. The distance from one point on a weld length to the same corresponding point on the next weld is called the **pitch**. The weld pitch is generally from center to center of weld lengths.

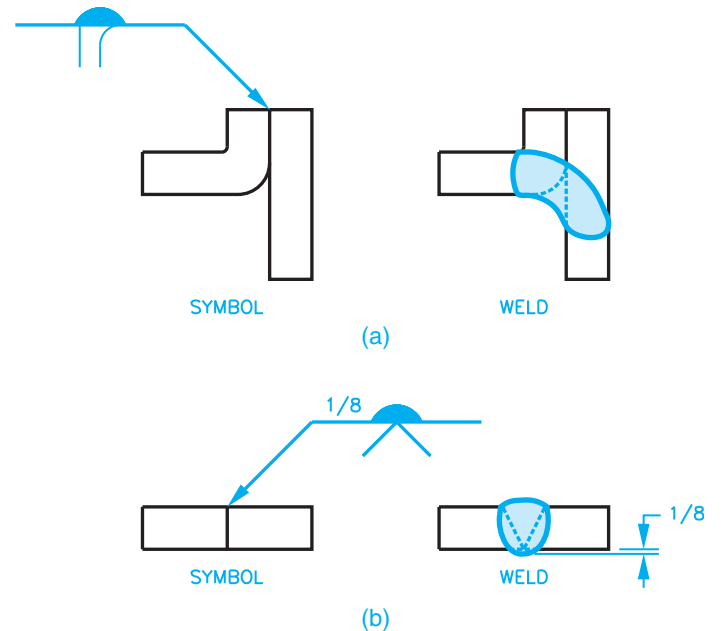
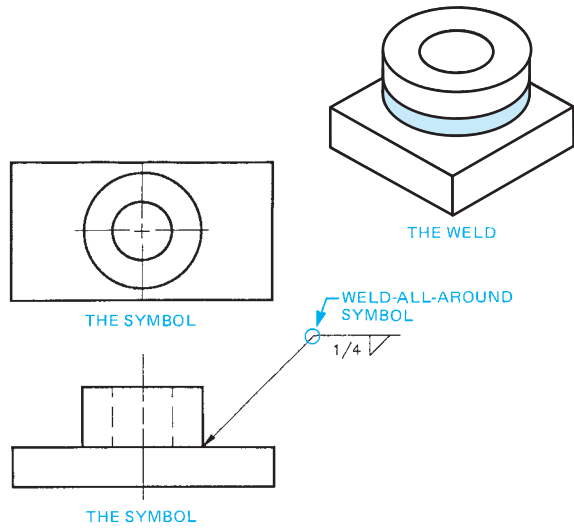


FIGURE 18.36 Application of the melt-through symbol and melt-through penetration dimension represented as 1/8 in the lower example. (a) Melt through used on a J-groove weld. (b) Melt through used on a V-groove weld. © Cengage Learning 2012

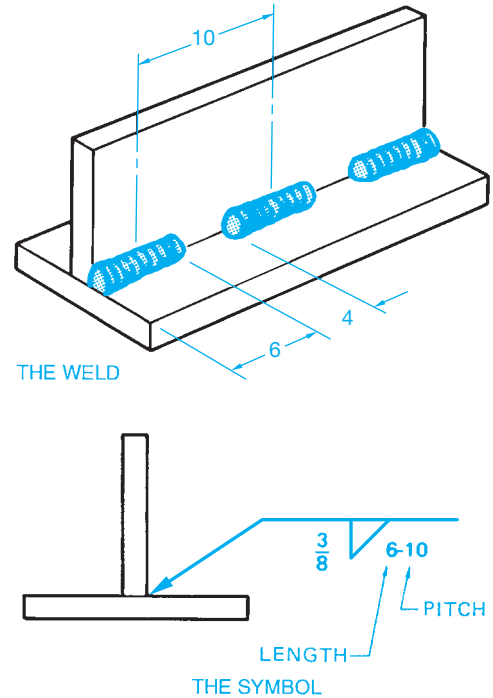


**FIGURE 18.37** Weld-all-around symbol used. Dimension values in this figure are in inches.

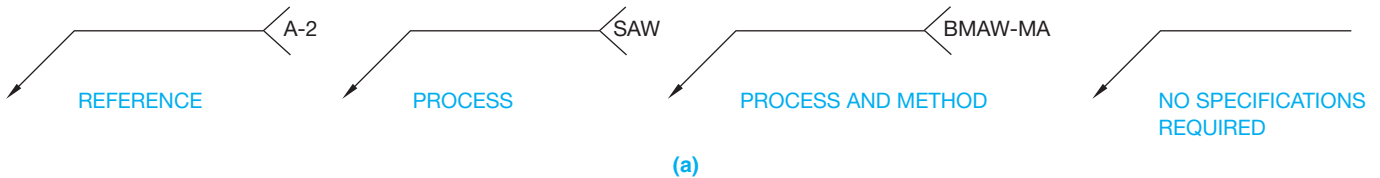
The weld length and pitch are shown to the right of the weld symbol, as shown in Figure 18.38. A weld is always continuous unless the welding symbol specifies a weld length and pitch.

### Welding Process Designation

The **tail** is added to the welding symbol when it is necessary to designate the welding specification, procedures, or other supplementary information needed to fabricate the weld (see Figure 18.39).



**FIGURE 18.38** Intermittent fillet weld. The weld length and pitch are given to the right of the weld symbol. Dimension values in this figure are in inches.



General	Welding Process	Letter Designation
Brazing	Torch brazing Induction brazing Resistance brazing	TB IB RB
Flow Welding Induction Welding	Flow welding Induction welding	Flow IW
Arc Welding	Bare metal arc welding Submerged arc welding Shielded metal arc welding Carbon arc welding	BMAW SAW SMAW CAW
Gas Welding	Oxyhydrogen welding Oxyacetylene welding	OHW OAW

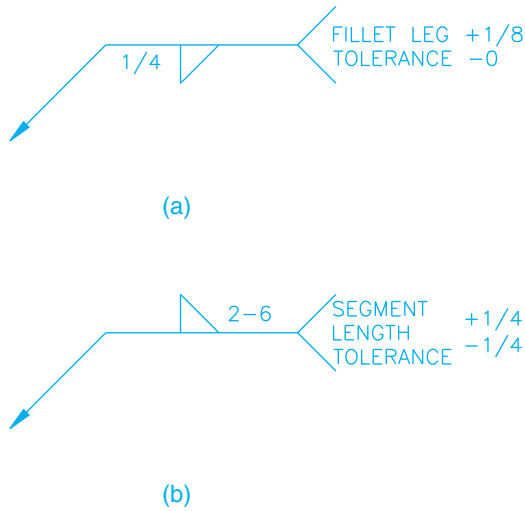
The following suffixes may be added if desired to indicate the method of applying the above processes:

- Automatic welding -AU
- Machine welding -ME
- Manual welding -MA
- Semiautomatic welding -SA

(b)

**FIGURE 18.39** (a) Location for weld specifications, process, and other references on weld symbols. (b) Designation of welding processes. © Cengage Learning 2012





© Cengage Learning 2012

**FIGURE 18.40** A weld tolerance applied to the welding symbol tail. Dimension values in this figure are in inches. (a) Fillet leg tolerance specification. (b) Segment length tolerance specification.

A **weld tolerance** can also be applied to a welding symbol tail by placing the tolerance value and a note giving a reference to the weld feature where the tolerance is applied as shown in Figure 18.40.

## Weld Joints

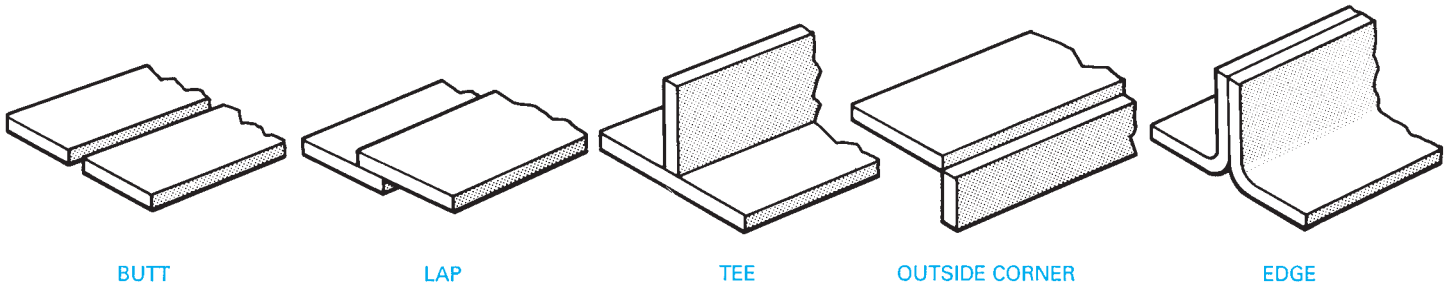
The types of **weld joints** are often closely associated with the types of weld grooves already discussed. The weld grooves can be applied to any of the typical joint types. The weld joints used in most weldments are the butt, lap, tee, outside corner, and edge joints shown in Figure 18.41.

## WELDING TESTS

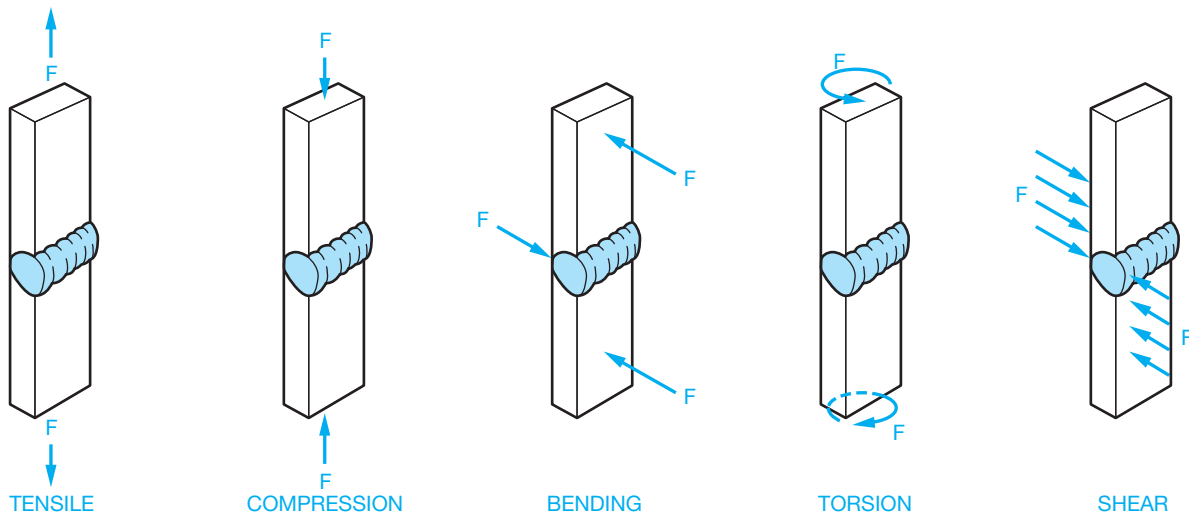
There are two types of welding tests: destructive and nondestructive.

### Destructive Tests (DT)

**Destructive tests (DT)** use the application of a specific force on the weld until the weld fails. These types of tests can include the analysis of tensile, compression, bending, torsion, or shear strength. Figure 18.42 shows the relationship of forces that can be applied to a weld. The **continuity** of a weld is when the desired characteristics of the weld exist throughout the weld length. **Discontinuity** or lack of continuity exists when a change in the shape or structure exists. The types of problems



**FIGURE 18.41** Types of weld joints. © Cengage Learning 2012



© Cengage Learning 2012

**FIGURE 18.42** Forces on a weld.

Type of Nondestructive Test	Symbol
Visual	VT
Penetrant	PT
Dye penetrant	DPT
Fluorescent penetrant	FPT
Magnetic particle	MT
Eddy current	ET
Ultrasonic	UT
Acoustic emission	AET
Leak	LT
Proof	PRT
Radiographic	RT
Neutron radiographic	NRT

FIGURE 18.43 Standard nondestructive testing symbols. © Cengage Learning 2012

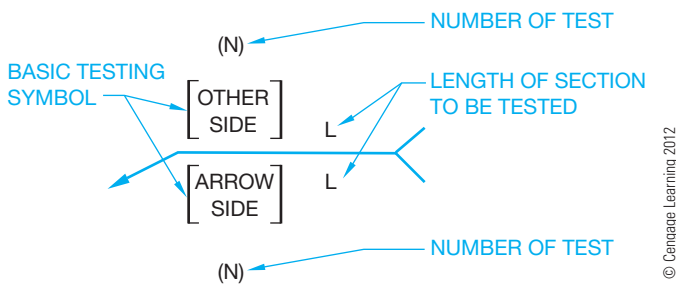


FIGURE 18.44 Basic nondestructive testing symbol.

that alter the desired weld characteristic can include cracks, bumps, seams or laps, and changes in density. The intent of destructive testing is to determine how much of a discontinuity can exist in a weld before the weld is considered to be flawed.

Parts can be periodically selected for destructive testing. The tested weld is unfit for any further use.

### Nondestructive Tests (NDS)

**Nondestructive tests (NDS)** are tests for potential defects in welds that are performed without destroying or damaging the weld or the part. The types of nondestructive tests and the corresponding symbol for each test are shown in Figure 18.43. The testing symbols are used in conjunction with the weld symbol to identify the area to be tested and the type of test to be used (see Figure 18.44).

The location of the testing symbol above, below, or in a break on the reference line has the same reference to the weld joint as the weld symbol application. Test symbols below the reference line mean arrow side tests. Symbols above the reference line are for other side tests, and a test symbol placed in a break on the line indicates no preference of side to be tested. Test symbols placed on both sides of the reference line require the weld to be tested on both sides of the joint (see Figure 18.45).

Two or more different tests can be required on the same section or length of weld. Methods of combining welding test symbols to indicate more than one test procedure are shown in Figure 18.46. The length of the weld to be tested can be shown to the right of the test symbol, or the weld test symbol can be shown on the reference line and the length of the weld to be tested can be dimensioned on the drawing (see Figure 18.47.). The number of tests to be made can be identified in parentheses below the test symbol for arrow side tests or above the symbol for other side tests as shown in Figure 18.48. The welding symbols and nondestructive testing symbols can be combined as shown in Figure 18.49. The combination symbol is appropriate to help the welder and inspector identify welds requiring special attention. When a radiograph test is needed, a special symbol and the angle of radiation can be specified, as shown in Figure 18.50.

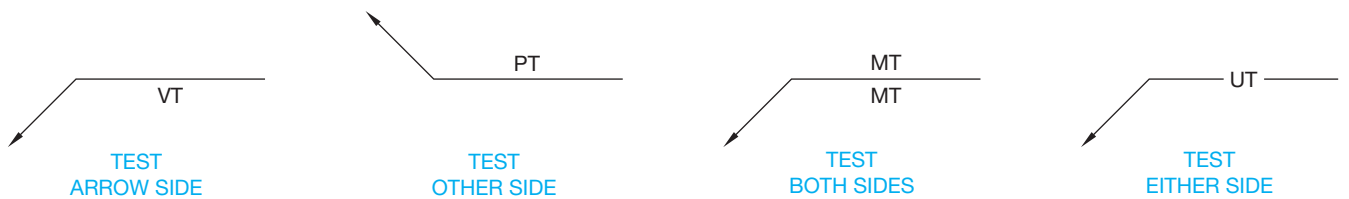


FIGURE 18.45 Testing symbols used to indicate the side to be tested.

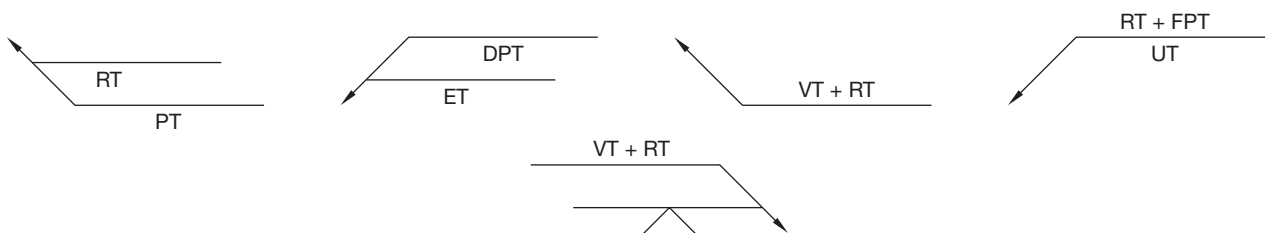
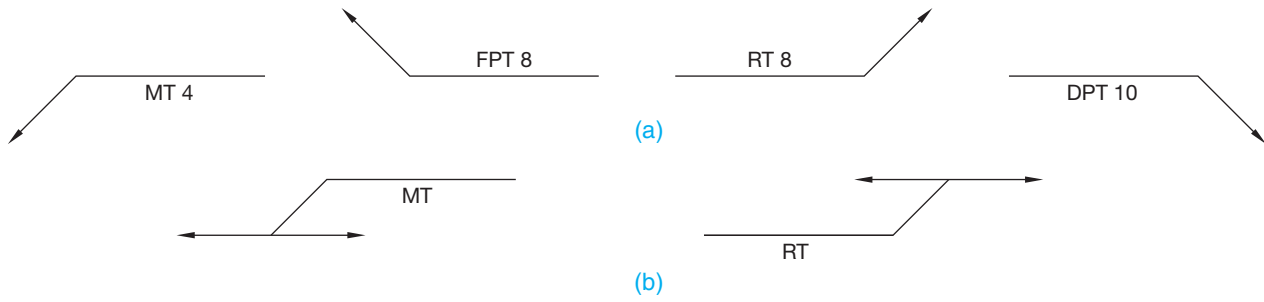
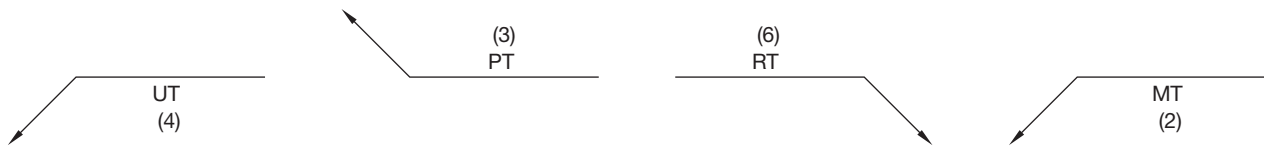


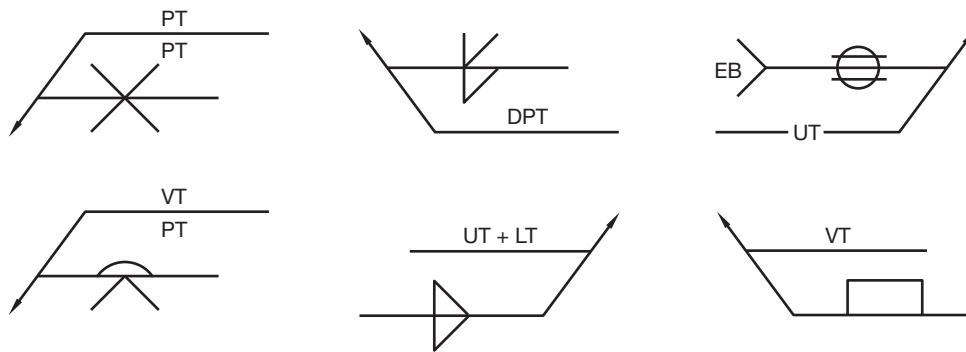
FIGURE 18.46 Methods of combining testing symbols.



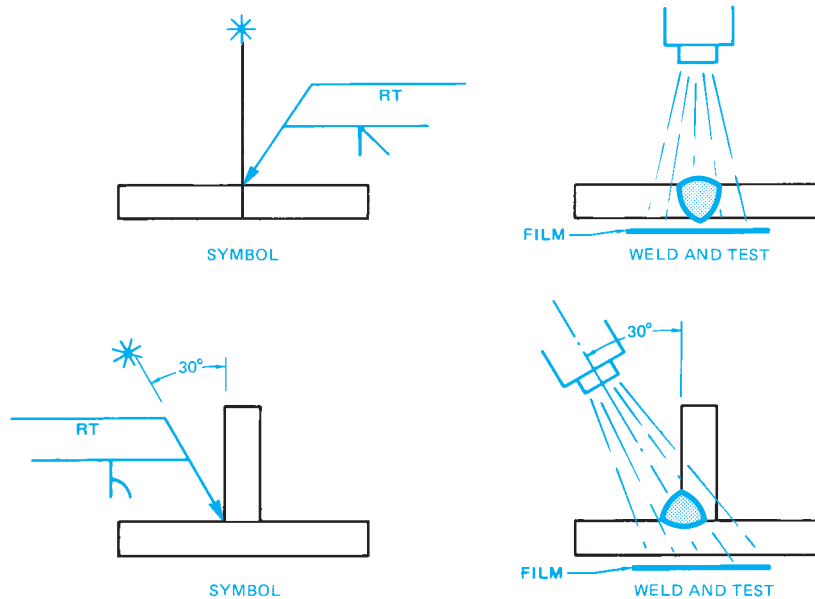
**FIGURE 18.47** Two methods of designating the length of weld to be tested. (a) The length of the weld to be tested is shown to the right of the test symbol. (b) The test symbol is shown on the reference line and the length of the required test is dimensioned on the drawing, which is not shown here.



**FIGURE 18.48** Method of specifying number of tests to be made.



**FIGURE 18.49** Combination welding and nondestructive testing symbols.



**FIGURE 18.50** Combination symbol for welding and radiation location for testing.

## WELDING SPECIFICATIONS

A **welding specification** is a detailed statement of the legal requirements for a specific classification or type of product. Products manufactured to code or specification requirements commonly must be inspected and tested to ensure compliance.

A number of agencies and organizations publish welding codes and specifications. The application of a particular code or specification to a weldment can be the result of one or more of the following requirements:

- Local, state, or federal government regulations.
- Bonding or insurance company requirements.
- Customer requirements.
- Standard industrial practice.

Commonly used codes include:

- No. 1104, American Petroleum Institute (API). Used for pipeline specifications.
- Section IX, American Society of Mechanical Engineers (ASME). Used to specify welds for pressure vessels.
- D1.1, American Welding Society (AWS). Welding specifications for bridges and buildings.
- AASHT, American Association of State Highway and Transportation Officials.
- AIAA, Aerospace Industries Association of America.
- AISC, American Institute of Steel Construction.
- ANSI, American National Standards Institute.
- AREA, American Railway Engineering Association.
- AWWA, American Water Works Association.
- AAR, Association of American Railroads.
- MILSTD, Military Standards, Department of Defense.
- SAE, Society of Automotive Engineers.

Note in the problem assignments that the welding specifications and notes are provided under SPECIFICATIONS and in the general notes.

## PREQUALIFIED WELDED JOINTS

### STANDARDS

**AISC/AWS** The American Institute of Steel Construction (AISC) and the Structural Welding Code of the American Welding Society (AWS) exempt from tests and qualification most of the common welded joints used in steel construction. These specific common welded joints are

referred to as **prequalified**. Work on prequalified welded joints must be in accordance with the Structural Welding Code. Generally, fillet welds are considered prequalified if they conform to the requirements of the AISC and the AWS code.

## WELD DESIGN

In most cases, the weld should be about as wide as the thickness of the metal to be welded. Undersized or oversized welds can result in joint failure. Undersized welds may not have enough area to hold the parts together under loading conditions. Oversized welds could result in a joint that is too stiff. The lack of flexibility in the oversized weld can cause the metal near the joint to become overstressed and result in failure adjacent to the weld joint. Welds between materials of different thickness should provide for more weld next to the thickest piece. If this design precaution is not taken, then the weld can result in good bonding to the thin material and poor bonding to the thick material, because the welding heat is more concentrated at the thinner material. Other options are to reduce the thickness of the thicker material or to build up the thickness of the thinner material at the weld joint.

**Welding design** is generally an engineering decision. Weld design can be as basic as previously described or complicated with the use of a variety of engineering formulas. Weld design can be different for each discipline, such as welding of machinery compared to the welding of steel structures. Engineers use a wide variety of different mathematical weld-stress formulas that are determined by factors involved in weld design based on the forces shown in Figure 18.42 and these characteristics:

- Welding process.
- Type of material.
- Weld joint.
- Type of weld, such as fillet or groove weld.
- Material thickness.
- Weld size.
- Bending and torsion properties of the material, weld joint, and weld type. **Torsion** refers to the twisting forces placed on features.

When weldments are used in the design, you must be able to recognize what the weld means and establish the best location on the drawing for the weld symbol. As entry-level drafters become familiar with company products and the welds used in them, under certain conditions they can be given more design-related tasks.

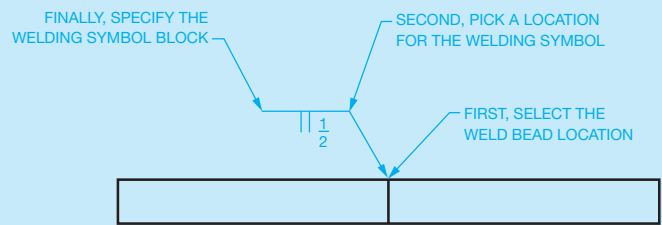
## WELDING SYMBOLS

Weld information is quickly and accurately added to drawings using CADD. Welding symbols contain shapes such as lines, circles, and arcs, and text is drawn with basic CADD tools and usually created using the dimension format or style and layer. Specific commands—including COPY, MOVE, OFFSET, MIRROR, and TRIM—also greatly aid in the process of adding any required welding symbol. Though welding symbols can be drawn using basic drafting commands such as LINE and TEXT, there are specific techniques that quickly and efficiently allow you to produce welding symbols complete with a leader. One example involves using a combination of AutoCAD BLOCK, LEADER, or QLEADER commands.

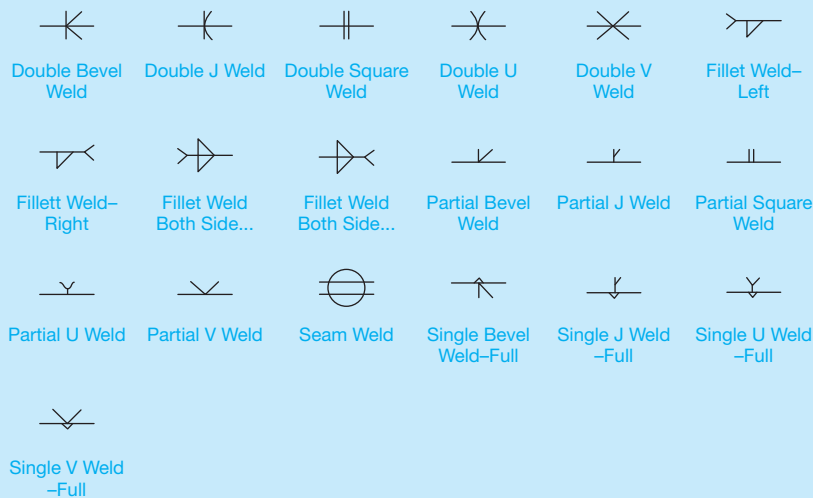
The BLOCK tool allows you to produce a weld symbol that can be stored in the current drawing file or a symbols library. One of the most powerful features of CADD software is the ability to reuse drawing content. This is especially true when designing and drafting welded products that contain multiple welding symbols. Often welding symbols are standard annotations that are used multiple times for several different projects. As a result, creating or purchasing a library of welding symbols can prove very beneficial. Reusing existing welding symbols and using welding symbol libraries can save a significant amount of time and allow designers and drafters to focus on the design and documentation of a product instead of the task of creating individual welding symbols using basic drawing tools. An example of a welding symbol library is shown

in Figure 18.51. This particular library contains several commonly used welding symbol blocks that can be easily added to a drawing.

The LEADER command allows you to use predefined dimension style settings to place a leader that references a particular welding symbol block. Once a welding symbol has been created and stored in the form of a block, you can use the block in place of text when you create a leader. This process typically involves picking points to define the length and location of the leader line followed by selecting the desired welding symbol block. Once the base symbol is inserted, you have the option of creating a unique welding symbol by editing the size of the weld bead information. Figure 18.52 shows how a leader may be used in CADD to quickly create a welding symbol by referencing a block.



**FIGURE 18.52** Creating a welding symbol using a leader and a block. Dimension values in this figure are in inches. © Cengage Learning 2012



**FIGURE 18.51** An example of a welding symbol library.

© Cengage Learning 2012

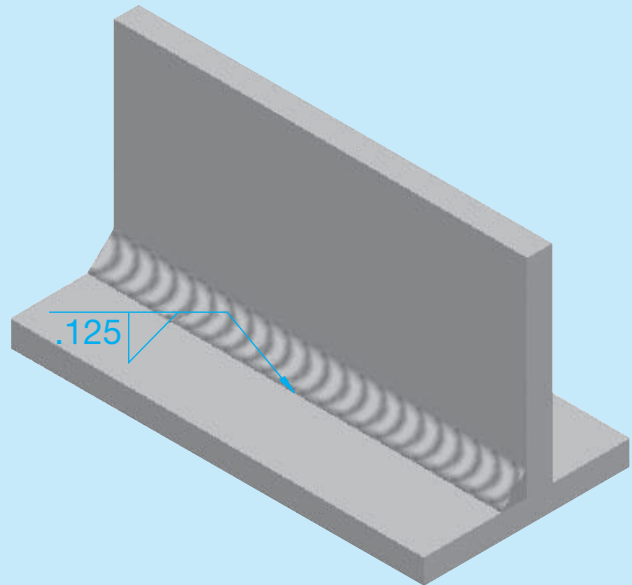
(Continued)

## CADD WELDING MODELS AND DRAWINGS

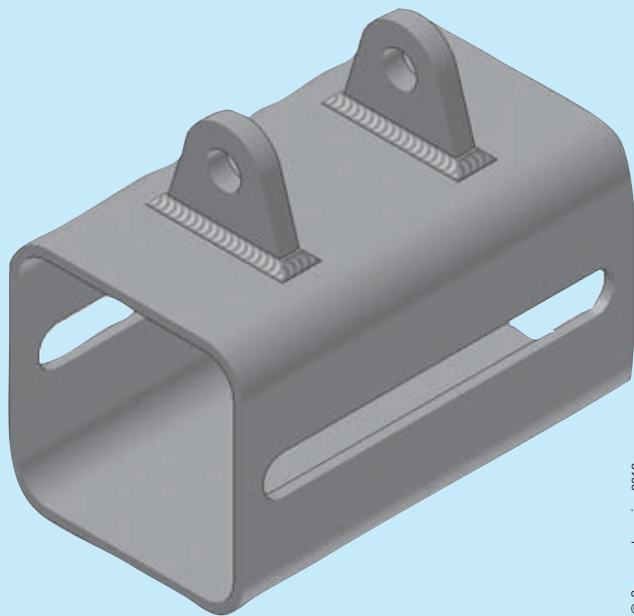
Some 3-D CADD programs incorporate very realistic welding processes into the modeling environment. One of the primary functions of 3-D CADD software is to model actual manufacturing procedures. The concept of generating a virtual model of a product is also applied to welding, as shown in Figure 18.53. Software is available that allows you to model a complete weldment, from the initial assembly of parts, to prewelding requirements such as adding a slot, hole, or groove to welding components, and finally postwelding processes such as drilling a hole through welded components.

Typically, when you create a weld bead in the 3-D model, all weld bead information is specified in a dialog box. The result is an accurate representation of a weld according to the required specifications. This information is available in the model for reference and modification and can also be used in a 2-D drawing. As described throughout this book, one of the benefits of using a 3-D CADD program that combines 2-D drawing capabilities is the power to dimension a drawing by referencing existing model information. For example, if you create a fillet weld in a model, the

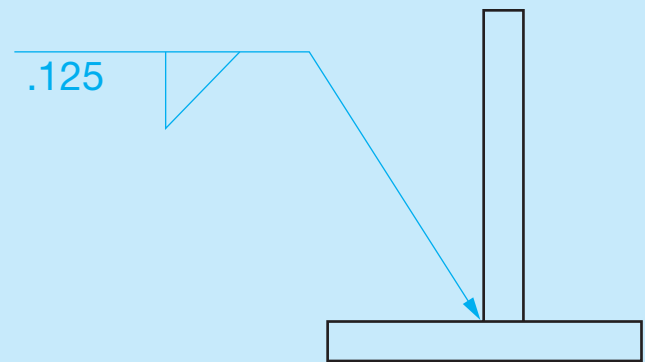
weld specifications are stored in the model, and it is just a matter of referencing the model weld parameters in the drawing to add a complete welding symbol to the drawing (see Figure 18.54). Also, because of the parametric nature of the software, welding symbols automatically update when changes are made to the specifications of the corresponding model.



(a)



**FIGURE 18.53** An example of a weldment model.



(b)

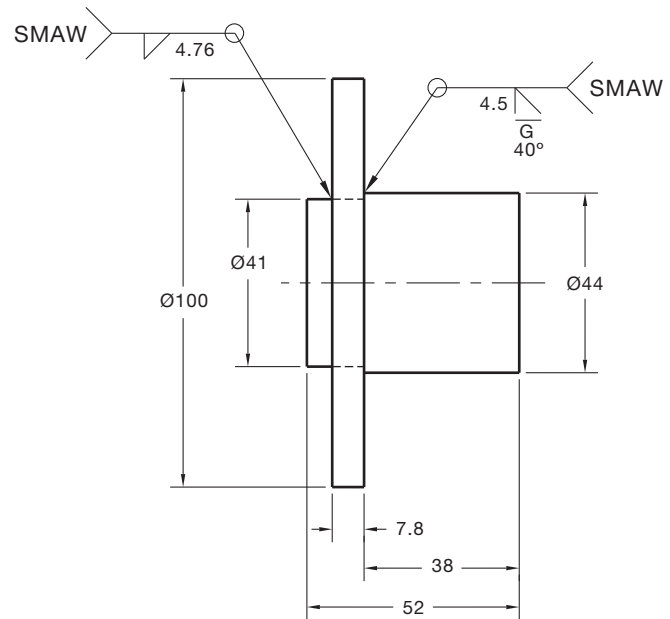
**FIGURE 18.54** (a) An example of a model weldment. (b) Referencing an existing welding symbol information on a drawing. © Cengage Learning 2012

## PROFESSIONAL PERSPECTIVE

Welding processes are used in many manufacturing situations from heavy equipment manufacturing to electronic chassis fabrication to steel building construction. Although the specific applications in these fields are different, the display of welding symbols is similar. If there is a strong chance that you will be employed as an engineering drafter in a field that performs a lot of welding operations, then it is a good idea to take a class in welding technology. Several classes may even be necessary for you to gain a good understanding of the welding methods and materials. The welding drafting standards and techniques discussed in this chapter are in accordance with the American Welding Society and the American Institute of Steel Construction. If you work in either mechanical engineering or steel construction and fabrication, then you should become familiar with the welding applications demonstrated and discussed in these standards.

As an entry-level drafter, your drafting assignments will probably be from engineer's sketches or prints marked for revision. As you gain some experience, the engineer can explain orally or in writing what needs to be done. As you gain experience, you can start to design with welding symbols based on the methods used at the company where you work, material thickness, and welding processes. Assume you are working as an engineering drafter with a mechanical engineer and that one of the parts for the project you are working on is a weldment. You have a good idea about what to do, but you ask the engineer for input. The engineer says, "Use a fillet weld all around on the diameter 41 side and a 4.5 mm deep bevel weld on the diameter 44 side

44 side, but be sure the bevel weld is ground smooth so it does not interfere with the mating part." You say, "Okay, now should the process be shielded metal arc welding?" The engineer indicates with a nod, "Yes, you have it!" Now you go back to work and come up with the drawing shown in Figure 18.55.



**FIGURE 18.55** The final drawing based on the given weld requirements.

© Cengage Learning 2012

### PERCENTAGE OF WELDED PARTS

**Problem:** Out of a lot of 1600 welded parts, 2% were rejected. How many were accepted?

**Solution:** This is a problem in percentages. Following percentage problem-solving terminology, the *base* is 1600 and the *rate* is 2 percent. The number of rejected parts is the *part*. To find the part, multiply:  $1600 \times .02$  and get 32. Then the number of accepted parts must be  $1600 - 32$ , or **1568**.

Another way to determine the number of accepted parts is to calculate 98% of the total parts made. If 2% of the parts were rejected, then 98% were accepted ( $100\% - 2\% = 98\%$ ). Using percentage problem solving again, the base is 1600 and the rate is 98%. To find the number of acceptable parts, multiply:  $1600 \times .98 = \mathbf{1568}$ .

The math problems for this chapter involve finding the base and rate as well as the part.


WEB SITE RESEARCH

The following Web site can provide you additional information for research or further study into topics covered in this chapter.

Address	Company, Product, or Service
www.aws.org	American Welding Society
www.amsi.org	American National Standards Institute
www.aisc.org	American Institute of Steel Construction
www.machinedesign.com	Welding processes listed

Chapter 18

Chapter 18 Welding Processes and Representations Test

 To access the Chapter 18 test, go to the Student CD, select **Chapter Tests and Problems**, and then **Chapter 18**. Answer the questions

with short, complete statements, sketches, or drawings as needed. Confirm the preferred submittal process with your instructor.

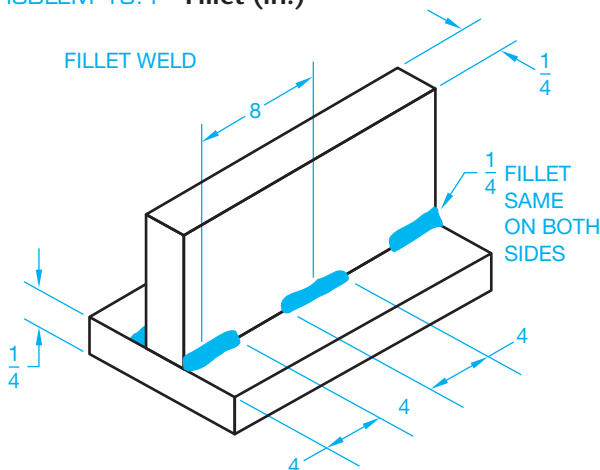
Chapter 18 Welding Processes and Representations Problems

INSTRUCTIONS

1. Given the engineer's sketches and layouts, draw the required number of views and proper welding symbols for each problem. Completely dimension unless otherwise specified.
2. For Problems 18.1 through 18.7, given the drawings showing actual welds or drawings and specifications, draw the necessary views and proper welding symbols. Use an appropriate ASME sheet size with border and sheet block.
3. For the remaining problems, draw the necessary views and completely dimension and place proper welding symbols. Use an appropriate ASME or architectural-style sheet size with border and sheet block based on the drawing content, unless otherwise specified by your instructor.

Part 1: Problems 18.1 Through 18.15

PROBLEM 18.1 Fillet (in.)

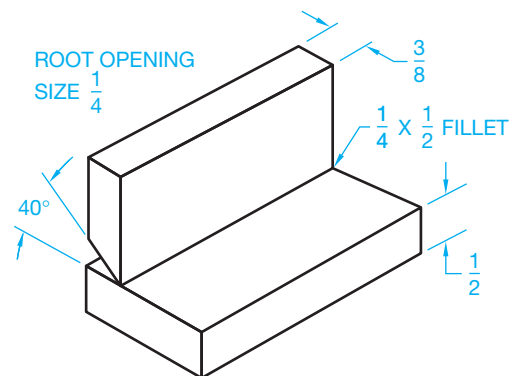


© Cengage Learning 2012

 Drafting Templates

To access CADD template files with predefined drafting settings, go to the Student CD, select **Drafting Templates**, and then select the appropriate template file.

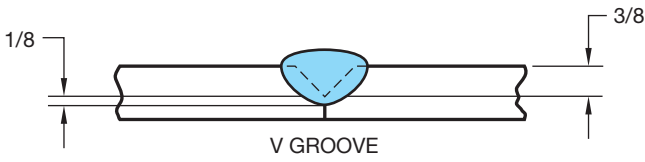
PROBLEM 18.2 Fillet and bevel groove (in.)



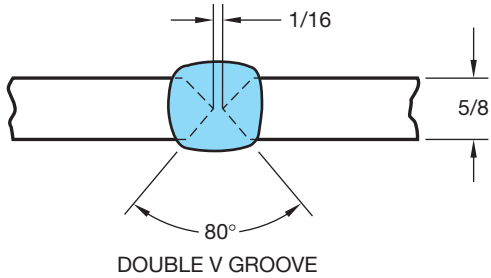
© Cengage Learning 2012



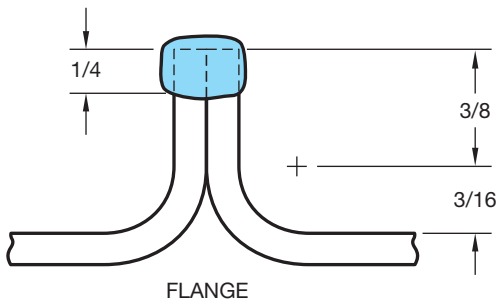
PROBLEM 18.3 V groove (in.)



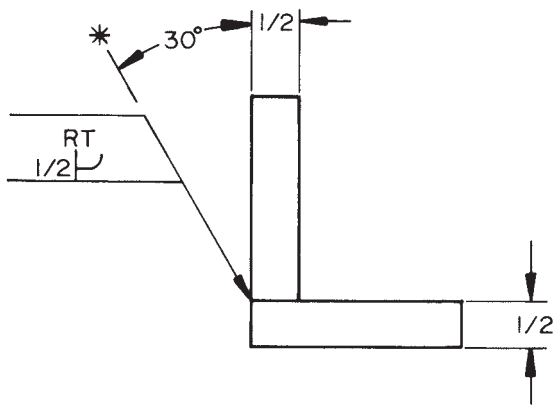
PROBLEM 18.4 Double V groove (in.)



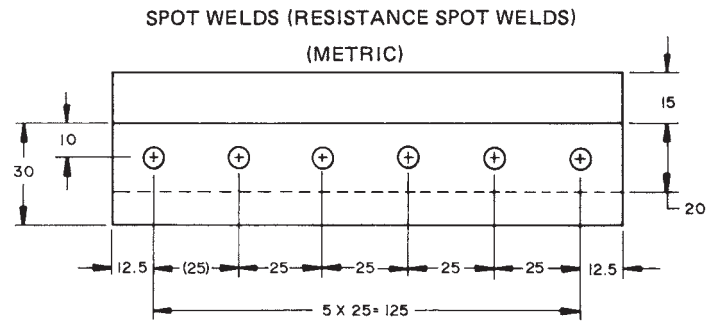
PROBLEM 18.5 Flange (in.)



PROBLEM 18.6 J groove weld with radiation test (in.)



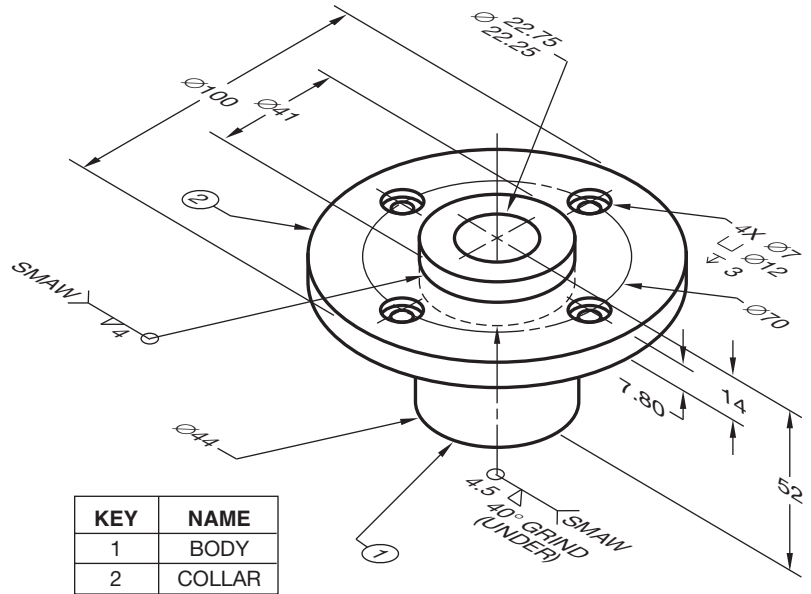
PROBLEM 18.7 Resistance spot weld (metric)



© Cengage Learning 2012

PROBLEM 18.8 (metric)

Part Name: Spring Housing Weldment  
Material: Mild steel (MS)

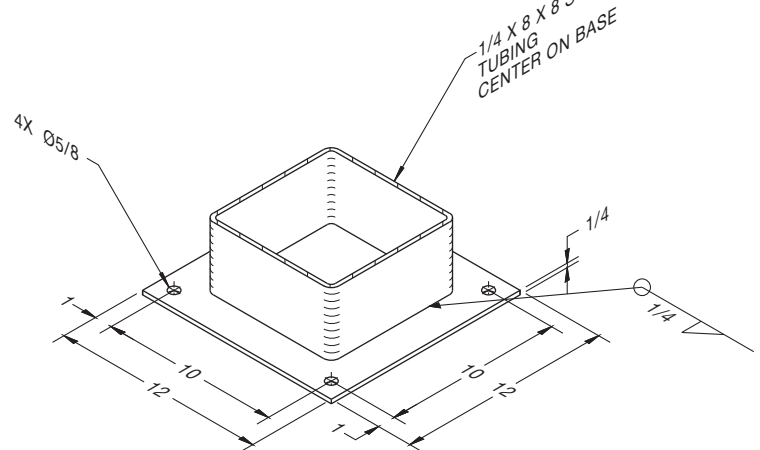


KEY	NAME
1	BODY
2	COLLAR

© Cengage Learning 2012

PROBLEM 18.9 (in.)

Drawing Name: Column Base Plate Detail  
Material: MS

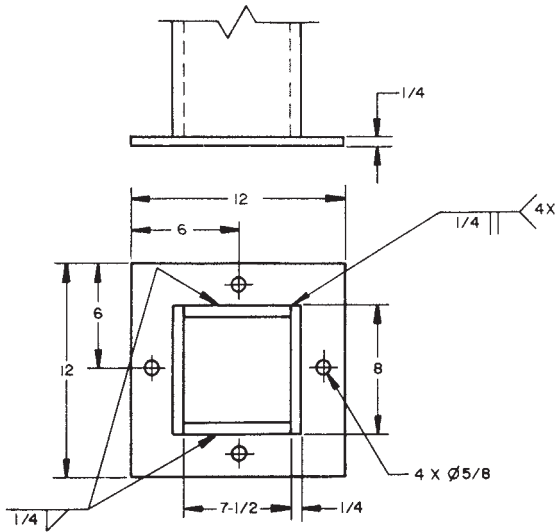


© Cengage Learning 2012

**PROBLEM 18.10 (in.)**

Drawing Name: Column Base Detail

Material: MS

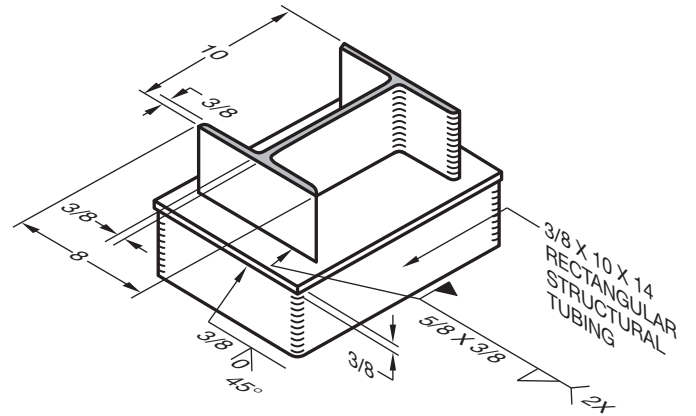


© Cengage Learning 2012

**PROBLEM 18.11 (in.)**

Drawing Name: Column Intersection Detail

Material: MS



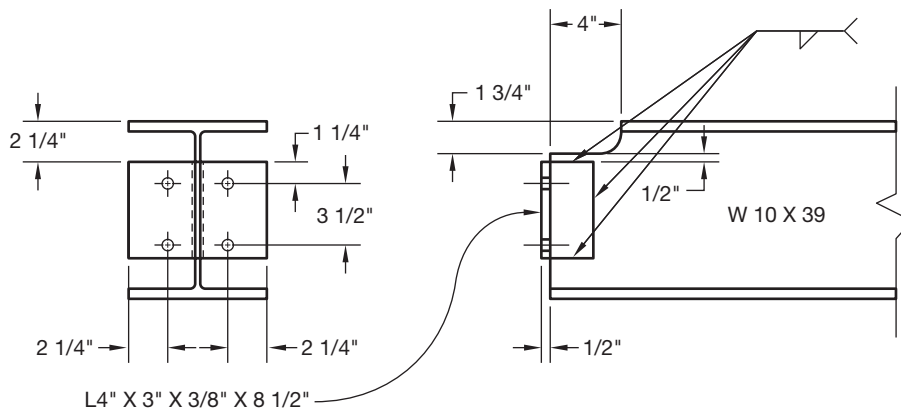
© Cengage Learning 2012

**PROBLEM 18.12 (in.)**

Drawing Name: Framed Beam Connection

Material: Steel

Dimensions of members: W10 X 39: depth = 9-7/8", width = 8", web thickness = 5/16", flange thickness = 1/2".



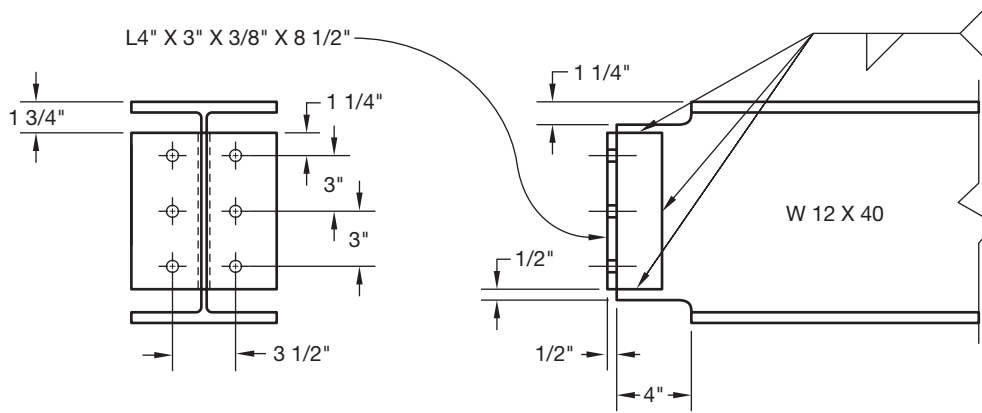
© Cengage Learning 2012

PROBLEM 18.13 (in.)

Drawing Name: Framed Beam Connection

Material: Steel

Dimensions of members: W12 X 40: depth = 12", width = 8", web thickness = 3/16", flange thickness = 1/2".



© Cengage Learning 2012

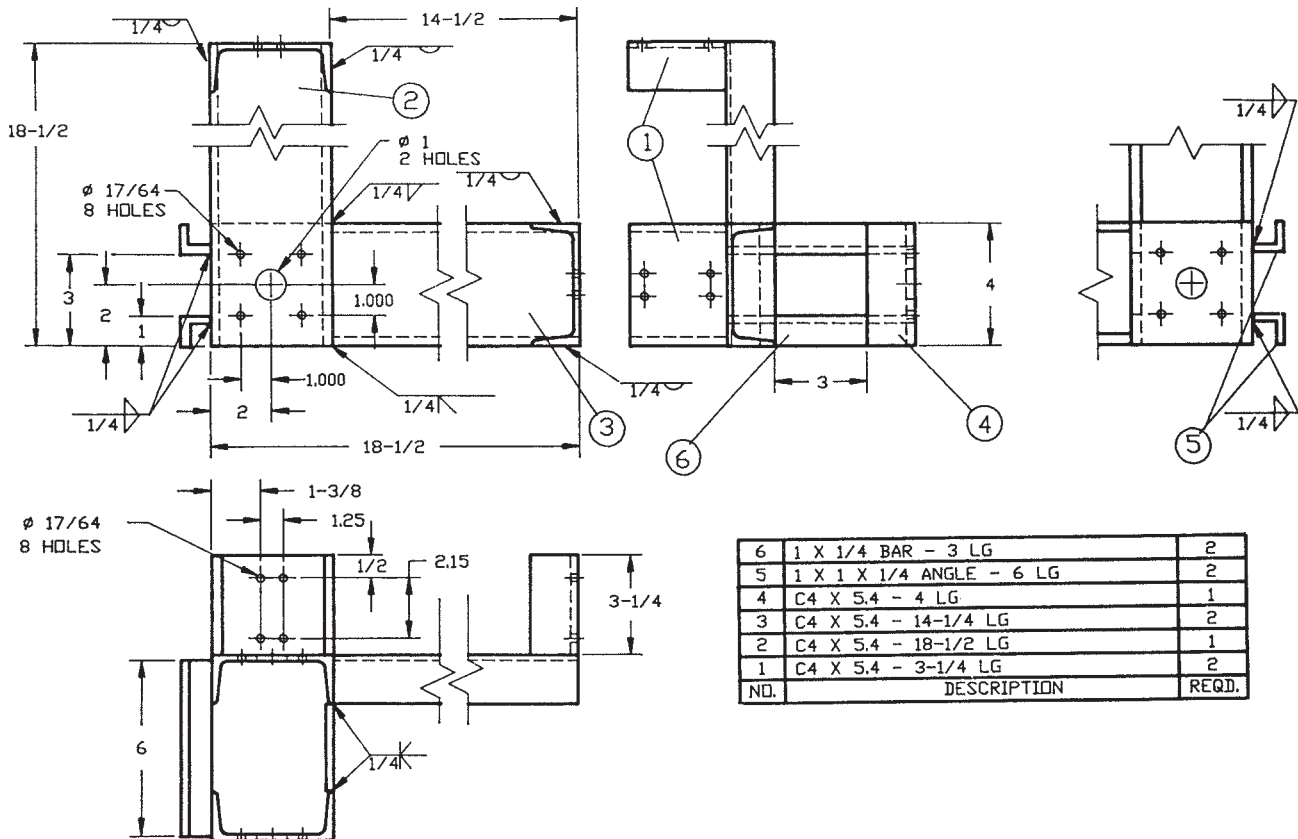
PROBLEM 18.14 (in.)

Drawing Name: Motor Support

Material: See materials list.

Dimensions of members: C4 X 5.4: depth = 4", width = 1-5/8", web thickness = 3/16", flange thickness = 5/16".

Courtesy Production Plastics



NO.	DESCRIPTION	REQD.
6	1 X 1/4 BAR - 3 LG	2
5	1 X 1 X 1/4 ANGLE - 6 LG	2
4	C4 X 5.4 - 4 LG	1
3	C4 X 5.4 - 14-1/4 LG	2
2	C4 X 5.4 - 18-1/2 LG	1
1	C4 X 5.4 - 3-1/4 LG	2

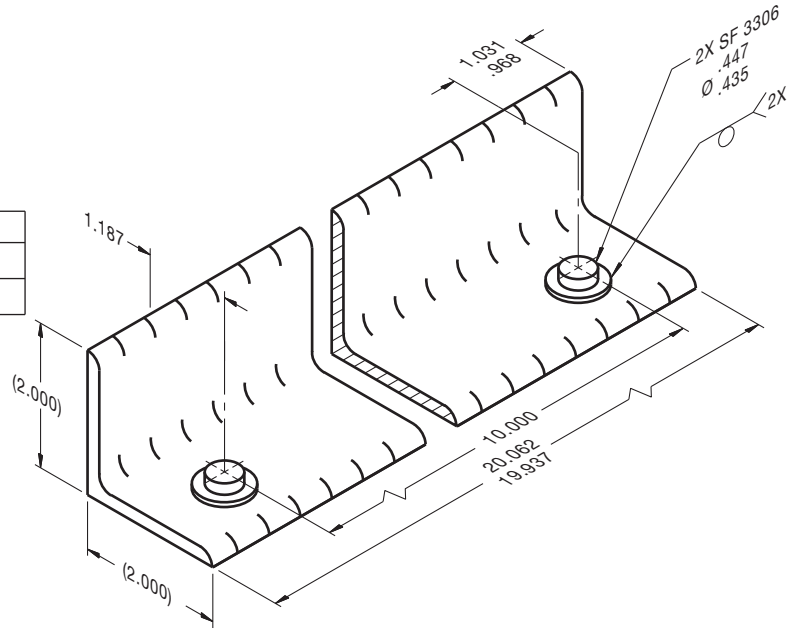
**PROBLEM 18.15 (in.)**

Drawing Name: Mounting Bracket

Material: See parts list.

Problem based on original art courtesy TEMCO.

2	WELD NUT	OHIO/ SF 3306 (3/8-16)
1	ANGLE	M821W200L2000 (2X2X3/16 A36)
-01	NAME OF PART	P/N DESCRIPTION MATERIAL



**Part 2: Problems 18.16 Through 18.23**



To access the Chapter 18 problems, go to the Student CD, select **Chapter Tests and Problems** and **Chapter 18**, and then open the problem of your choice or as assigned by your instructor. Solve the problems using the instructions provided on the CD, unless otherwise specified by your instructor.

**Math Problems**

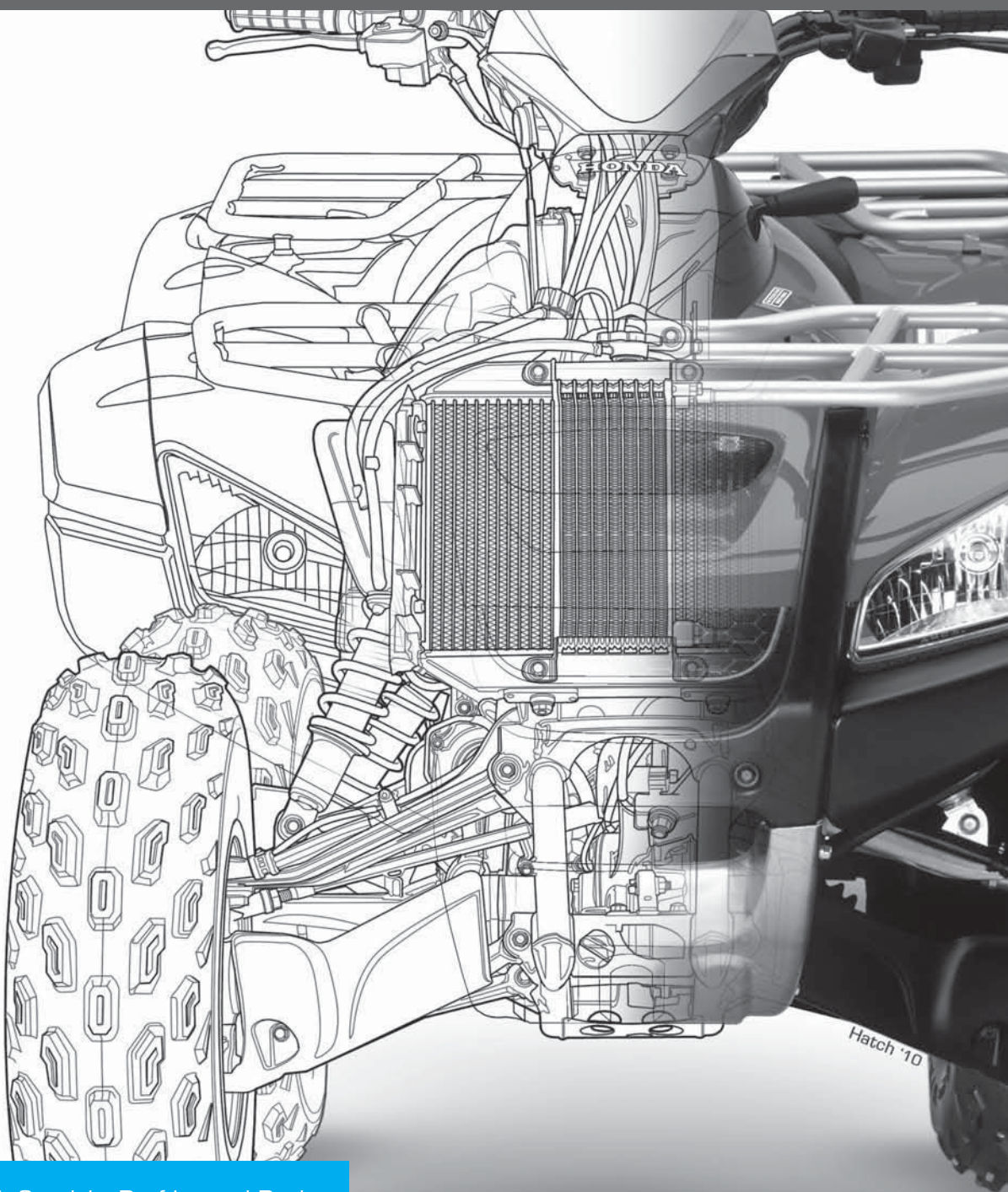
**Part 3: Problems 18.24 Through 18.33**

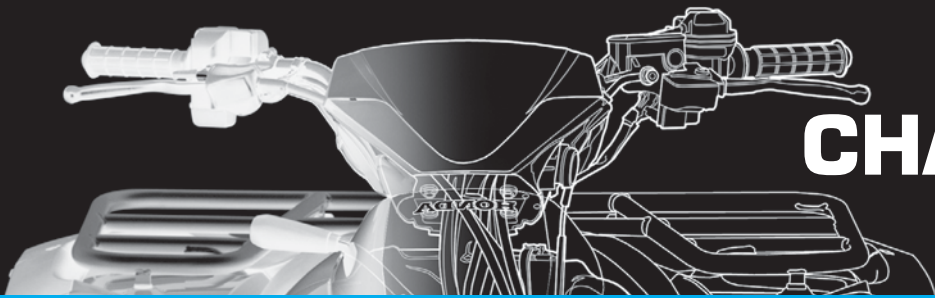


To access the Chapter 18 problems, go to the Student CD, select **Chapter Tests and Problems** and **Chapter 18**, and then open the math problem of your choice or as assigned by your instructor. Solve the problems using the instructions provided on the CD, unless otherwise specified by your instructor.



Specialty Drafting and Design





# CHAPTER 19

## Precision Sheet Metal Drafting

### LEARNING OBJECTIVES

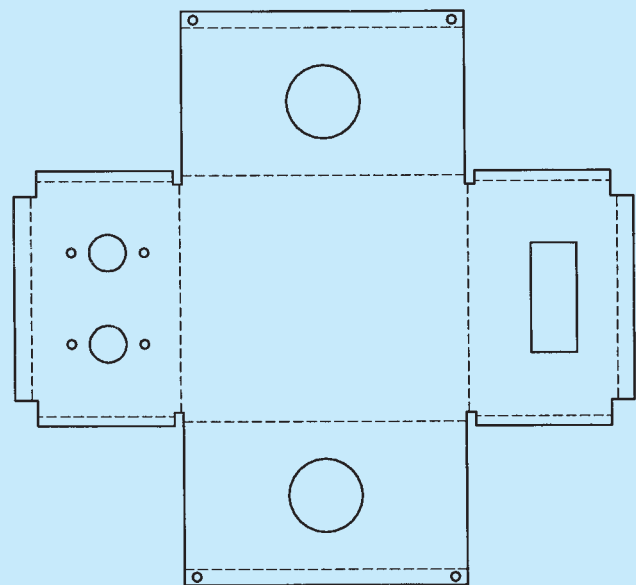
After completing this chapter, you will:

- Calculate and apply bend allowances to sheet metal components.
- Draw and completely dimension precision sheet metal fabrication drawings.
- Use an engineering problem as an example for precision sheet metal drawing solutions.

### THE ENGINEERING DESIGN APPLICATION

Your company produces a wide variety of sheet metal products for various customers, ranging from precision housing structures for electronic equipment to automotive body parts. Your current drawing project is a chassis for an electronic testing device. The final development requires tight tolerances for all of the components to mount properly within the chassis. Calculating bend allowances allows you to determine the required size of the flat pattern.

Although there are a number of methods for determining bend allowance, a good source is to reference the tables listed in the *Machinery's Handbook*. By checking the table for the type of metal you are using, plus the bend radius and thickness of material, you can determine the appropriate bend allowances. Applying the bend allowance to each bend in the flat pattern makes sure that the desired final dimensions can be achieved when the material is formed into its final shape. Figure 19.1 shows the flat pattern layout for the electronic chassis cabinet used in this example.



© Cengage Learning 2012

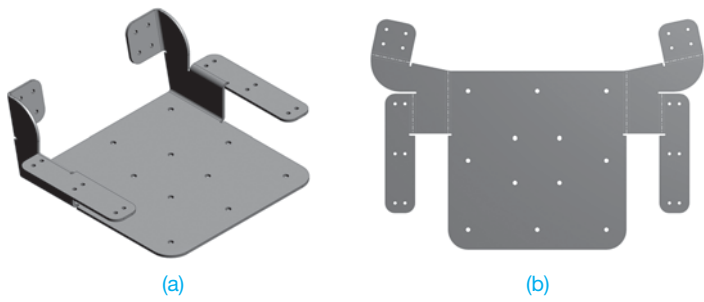
FIGURE 19.1 Sample flat pattern layout for the engineering problem.

### INTRODUCTION TO PRECISION SHEET METAL DRAFTING

The term **precision sheet metal drafting** is used in this chapter to refer to sheet metal parts that are designed and manufactured with tighter tolerances than are normally associated with sheet metal parts used in construction applications such as the heating, ventilating, and air-conditioning (HVAC) industry discussed in Chapter 23 of this textbook. The term **sheet metal** refers to metal that has been rolled into a sheet. Sheet metal thicknesses vary, depending on the application. Extremely thin sheet metal thicknesses are referred to as **foil** or **leaf**. Sheet

metal thickness generally ranges between .03 in. (0.75 mm) and 25 in. (6 mm). Sheet metal typically thicker than 6 mm (0.25 in.) is called **plate**. Sheet metal is available as flat pieces or as a coiled strip. The thickness of the sheet metal is referred to as **gauge**. The gauge of sheet metal ranges from 30 gauge to about 8 gauge. The higher the gauge, the thinner the metal. Sheet metal and plate lengths are up to 20 feet (6000 mm).

Sheet metal can be made from most metals, but the common materials are carbon steel, aluminum, stainless steel, copper, brass, and some plastics. Other materials include tin, nickel, titanium, silver, gold, and platinum. Sheet metal can be cut and bent into a variety of different shapes, with common applications in products



**FIGURE 19.2** (a) An example of a formed sheet metal part, an aluminum frame for a boat seat. (b) The unfolded or flat pattern of the formed part shown in Figure 19.2a.  
© Cengage Learning 2012

you use every day, such as kitchen appliances, automobile bodies, and electronics equipment. The terms **sheet metal parts** and **products** are used throughout this chapter to refer to precision sheet metal parts and products. Sheet metal products are common in the automotive, electronic, product chassis, and aircraft industries. Drafters follow specific techniques and commonly use specialized CADD tools and options to design and document sheet metal parts. Sheet metal parts are parts formed from a flat sheet of metal. Figure 19.2a shows an illustration of a formed sheet metal part. The formed sheet metal part begins as a flat pattern of the part design. A **flat pattern** is a 2-D drawing representing the initial, unfolded part ready for processing with machine tools to create the final part. Figure 19.2b shows the flat pattern of the sheet metal part shown in Figure 19.2a. Manufacturers can input CADD drawing and model data into software that controls sheet metal part production and transfers a flat pattern to a sheet of metal. The metal is

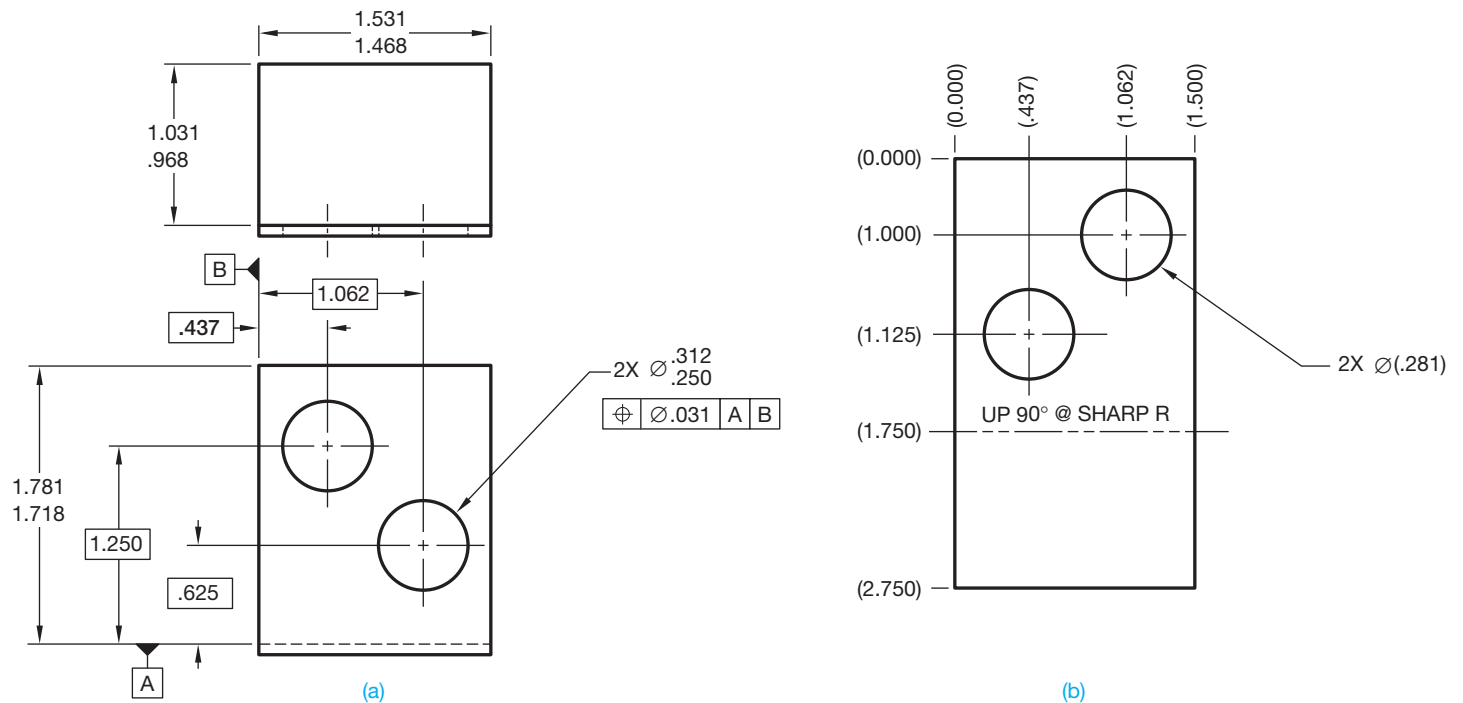
then cut, drawn, stretched, and bent to the correct specifications. The term **cut** refers to any process, such as shearing, punching, laser, water jet, and any similar process that is used to remove material. The term **bent** or **bend** refers to metal being formed using a stake, brake, folder, die, roller, or similar tool. You can also use sheet metal drafting for any application or material that requires similar forming and flat pattern processes, such as cardboard package design, plastic component design, and fabric panel design.

## PRECISION SHEET METAL LAYOUT OPTIONS

Electronic assemblies often require shields, frames, panels, and chassis. Layout drawings are required for the fabrication of these items. Preparing chassis layouts and other precision sheet metal drawings requires close tolerances and bend allowance calculations. Bend allowance is described later in this chapter. The method of dimensioning sheet metal parts includes standard unidirectional, rectangular coordinate dimensioning without dimension lines, and tabular dimensioning systems. Chapter 10, *Dimensioning and Tolerancing*, described dimensioning applications. A precision sheet metal pattern can be drawn a number of different ways, depending on the preferred company practice. The following describes typical applications.

### Multiview Drawing and Flat Pattern

One application for presenting a sheet metal part is to use a multiview drawing showing the part in its final bent form. Figure 19.3a shows the multiview drawing of a sheet metal part.



**FIGURE 19.3** (a) This method shows the multiview drawing of a sheet metal part. The multiview drawing displays the part in its bent form, and the features are dimensioned using unidirectional dimensioning. (b) The flat pattern is shown and dimensioned using rectangular coordinate dimensions without dimension lines. © Cengage Learning 2012



The multiview drawing shows the part in its bent form. This example uses unidirectional dimensioning to dimension features. Figure 19.3b shows the flat pattern of the sheet metal part. This example uses rectangular coordinate dimensions without dimension lines to dimension features.

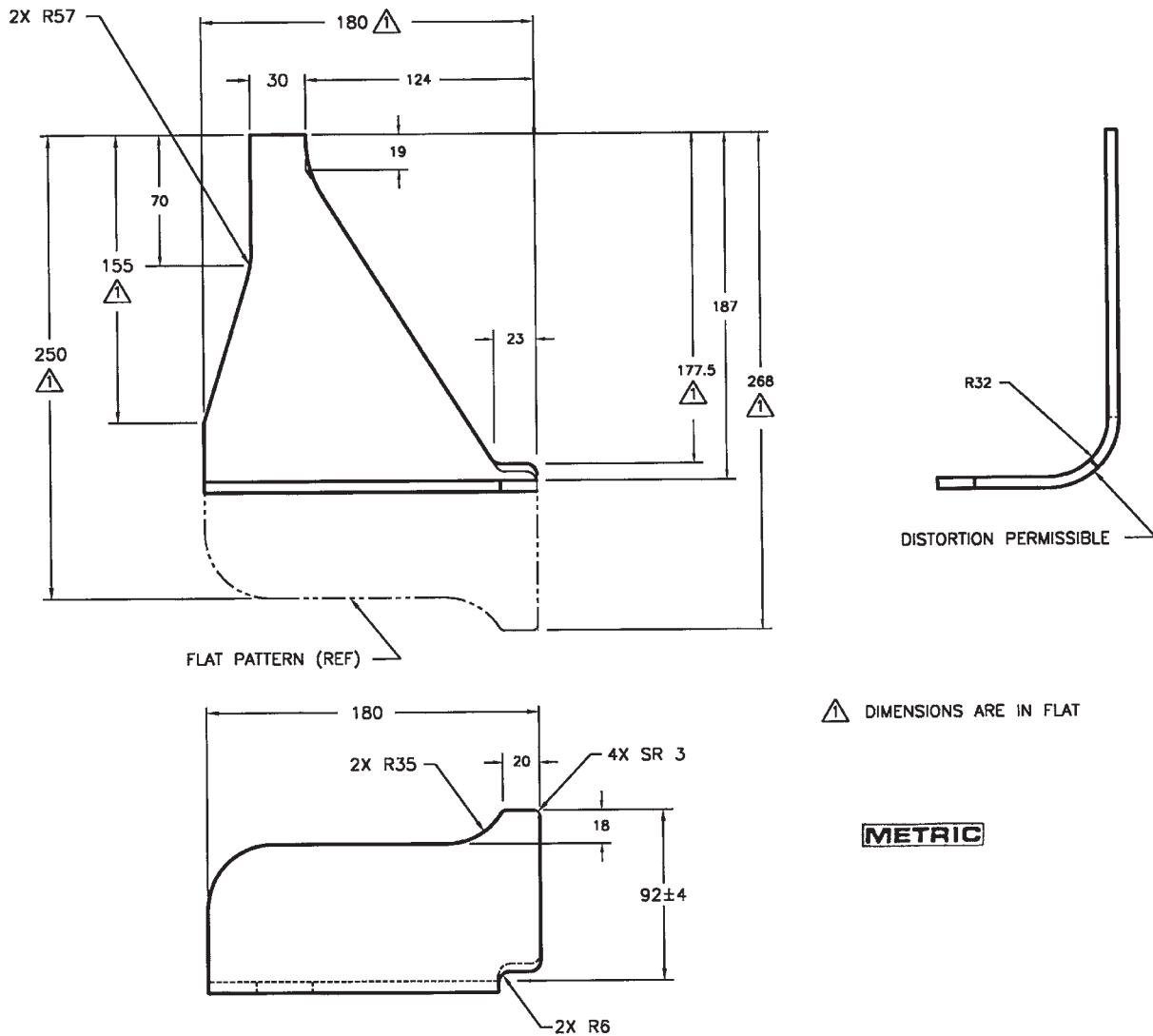
### Multiview Drawing with Flat Pattern Reference Using Phantom Lines

Another option for drawing a sheet metal part is to draw the multiviews of the part representing the final bent condition and to draw the flat pattern reference on one of the other views using phantom lines. Figure 19.4 shows a multiview drawing of a final bent sheet metal part dimensioned using unidirectional dimensioning. The flat pattern reference is shown extended from the

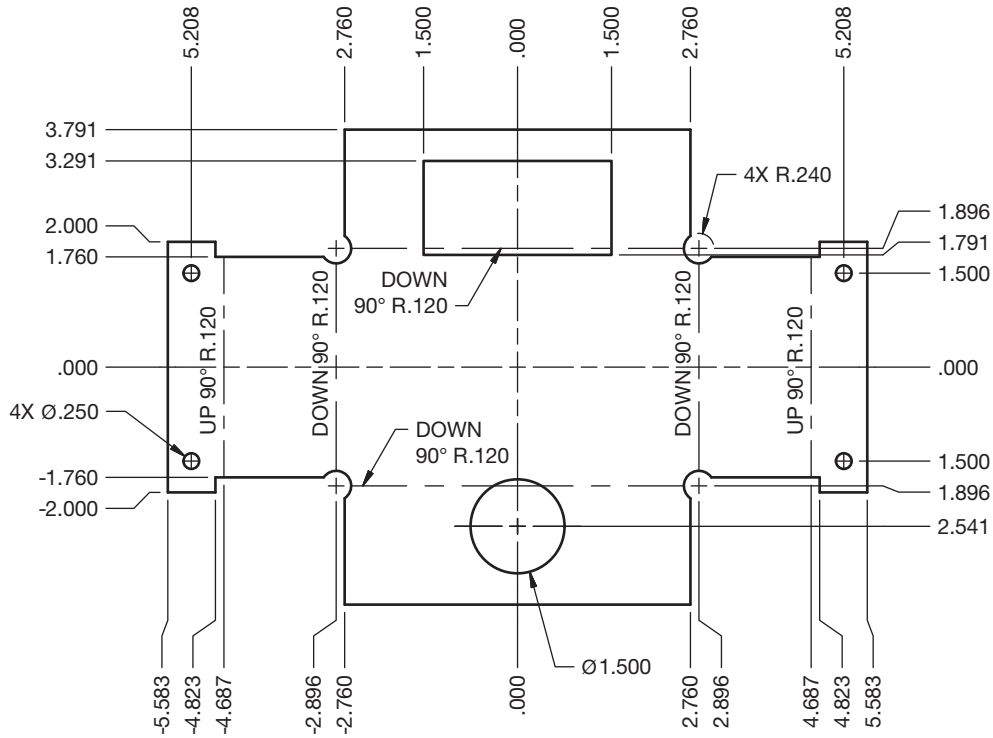
front view using phantom lines and is labeled for reference. Notice the delta dimensions that identify features dimensioned in the flat pattern. This application is an option used by some companies, but it is one of the least common methods for drawing a sheet metal part.

### Flat Pattern Using Rectangular Coordinate Dimensioning Without Dimension Lines

A common method for representing a sheet metal part is by drawing only the flat pattern and using rectangular coordinate dimensioning without dimension lines. The flat pattern dimensions take into consideration material bending so that the final bent part is exactly as designed. Figure 19.5 shows a flat pattern drawing of a sheet metal part dimensioned using rectangular



**FIGURE 19.4** This option for drawing a sheet metal part is to draw the multiviews of the part representing the final bent condition, and the flat pattern reference is shown extended from the front view using phantom lines and is labeled for reference.



**FIGURE 19.5** A sheet metal part using the flat pattern drawing with rectangular coordinate dimensioning without dimension lines. In this example, leader lines and specific notes dimension circular features.

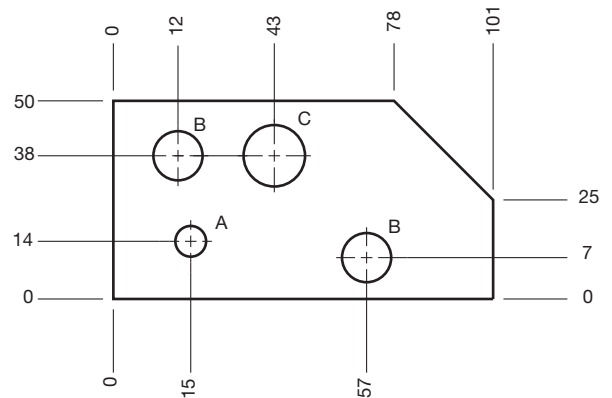
© Cengage Learning 2012

coordinate dimensioning without dimension lines. In this example, leader lines and specific notes dimension circular features. The drawings also show centerlines for bend lines with text or arrow indicating the bend direction.

### Flat Pattern Using Rectangular Coordinate Dimensioning Without Dimension Lines and Tabular Dimensioning

A common method for representing a sheet metal part is by drawing only the flat pattern using rectangular coordinate dimensioning without dimension lines and by identifying features with letters on the flat pattern. A table correlates with the letters on the flat pattern and specifies the dimensions of each labeled feature. The flat pattern dimensions take into consideration material bending so that the final bent part is exactly as designed. Figure 19.6 shows a flat pattern drawing of a sheet metal part dimensioned using rectangular coordinate dimensioning without dimension lines. In this example, the features are dimensioned in a table that correlates to letters on the flat pattern.

Figure 19.7 shows another example of representing a sheet metal part by drawing only the flat pattern and using rectangular coordinate dimensioning without dimension lines and tabular dimensioning. In this example, tabular dimensioning provides the size and location dimensions of each feature in a table. Identification letters correlate the features between the flat pattern view and the table.



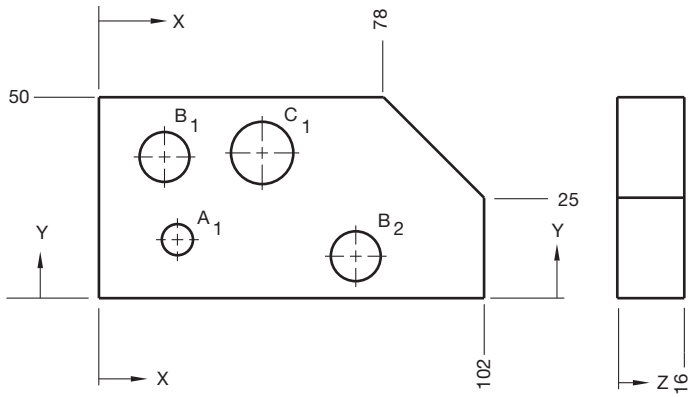
HOLE SYMBOL	HOLE DIA	QTY
A	6	1
B	9	2
C	12	1

Courtesy Hyster Company

**FIGURE 19.6** A sheet metal part using the flat pattern drawing with rectangular coordinate dimensioning without dimension lines.

### Formed Sheet Metal Part Model and Flat Pattern

Some CADD systems provide tools and options that assist building an accurate 3-D model of a formed sheet metal part. The model is used for design and manufacturing; it can be



HOLE SYMBOL	HOLE DIA	LOCATION		DEPTH
		X	Y	Z
A <sub>1</sub>	6	15	14	THRU
B <sub>1</sub>	9	12	38	9
B <sub>2</sub>	9	57	7	12
C <sub>1</sub>	12	43	38	THRU

**FIGURE 19.7** A sheet metal part using the flat pattern drawing with tabular dimensioning. Tabular dimensioning provides the feature location dimensions and feature sizes in a table. Identification letters correlate the features between the flat pattern view and the table. © Cengage Learning 2012

unfolded to create a flat pattern and can be shown as a pictorial representation on a 2-D drawing. A flat pattern extracted from a folded part model can be dimensioned using standard unidirectional, rectangular coordinate dimensioning without dimension lines or by using tabular dimensioning systems. The flat pattern dimensions take into consideration material bending so that the final bent part is exactly as designed. Figure 19.8 shows a 3-D folded sheet metal part model and the related flat pattern drawing dimensioned using standard unidirectional dimensioning. The practice of showing the sheet metal part model can be used with any of the previously described methods for displaying and dimensioning the sheet metal flat pattern.

### Flat Pattern with Manufacturing Information Extracted to a Table

**Tables** are commonly used for a variety of drafting applications, including tabular dimensioning. A table is an arrangement of rows and columns that organize data to make it easier to read. Some CADD applications allow you to extract existing model or drawing data to form a table. For example, you can create a **hole table** from hole features or a **bend table** from sheet metal bends. You can also create general tables for other applications. The following information focuses on hole, bend, and general tables. A hole table is a common form of tabular dimensioning that specifies the size and location of holes using a table. A bend table is a table that indicates the location and parameters of sheet metal bends.

Figure 19.9 shows a 3-D formed sheet metal part model and the corresponding flat pattern drawing; hole feature data has been extracted from the model to create a hole table, and bend parameters have been extracted from the model to form a bend table.

### STANDARDS

**ASME** The standard ASME Y14.31-2008, *Undimensioned Drawings*, provides the requirements for undimensioned drawings that graphically define objects with true geometry views and predominantly without dimensions. This standard also provides recommendations for drawing and noting bend lines and bend information.

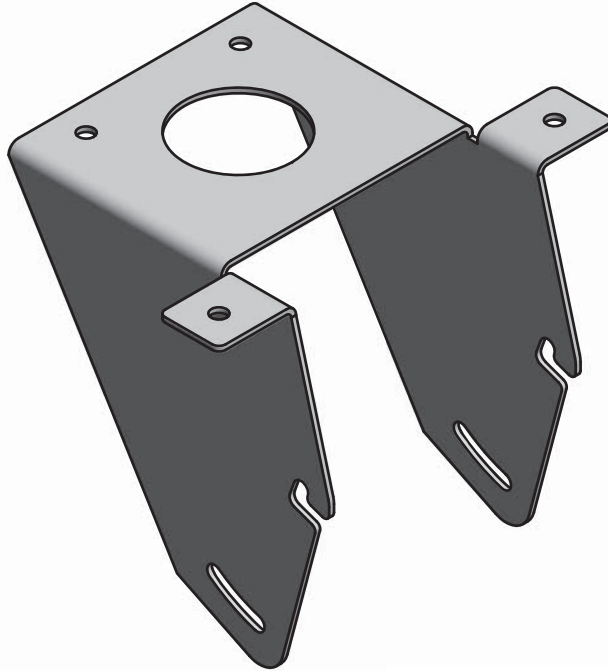
### Bend Representation and Instructions

As you look at the sheet metal pattern drawing examples in Figures 19.3 through 19.9, notice that the bend line is drawn using a centerline type. Some companies use a phantom line type to represent the bend line. **Bend instructions** are placed in a note next to the bend line. Bend instructions generally specify the number of degrees of the bend and the bend direction from the **principal plane**. The principal plane is the surface from which the bend is formed. Bend instructions are placed on the principal plane when possible. Place the bend instructions outside and adjacent to the principal plane when there is not enough space on the principal plane. Bend instructions can have a variety of formats, but they commonly specify the bend direction, bend angle, and bend radius. The following are examples of bend instructions:

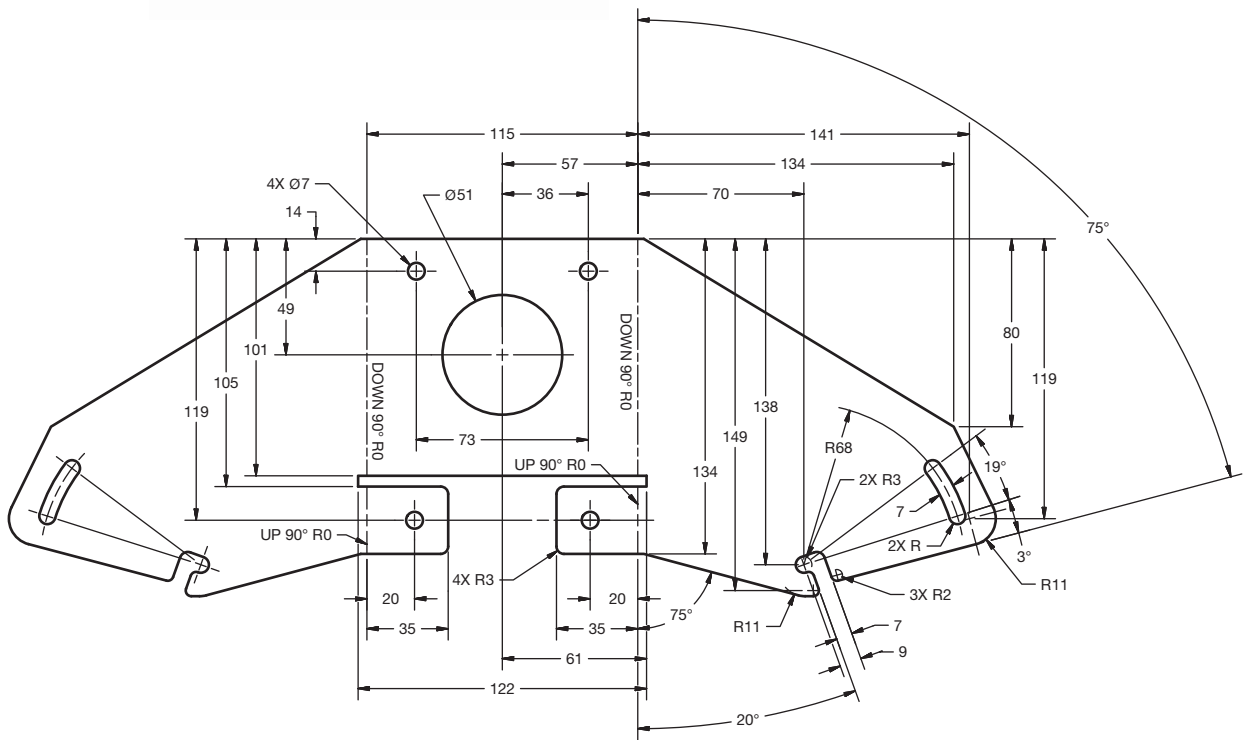
Note	Meaning
UP 90° R .120	Bend up 90° with a .120 bend radius.
DOWN 90° R .120	Bend down 90° with a .120 bend radius.
DN 90° R .120	Bend down (DN) 90° with a .120 bend radius.
BUP 90° × R 250	Bend up (BUP) 90° with a .250 bend radius.
BDN 90° × R 250	Bend down (BDN) 90° with a .250 bend radius.

If the bend instructions are not obvious when placed on the principal plane, then a note with a leader should point to the bend feature that reads BEND THIS SURFACE. When the leader points to a surface, the arrowhead is replaced with a dot that is .06 in. (1.5 mm) in diameter.

Sheet metal models and sheet metal pattern drawings can include additional information such as the **bend tangent line**, **center line of bend (CLB)**, **inside mold line (IML)**, and **outside mold line (OML)**. The bend tangent line is the line where the flat surface of a part is tangent to the bend radius. The bend tangent line is drawn using a phantom line type when placed on the sheet metal part model. The CLB is a line placed half the distance between bend tangents. The CLB is drawn using a centerline type and indicates the straight line of contact where the brake press bar strikes the pattern to form the bend. The IML is drawn using a centerline type and is a line representing the



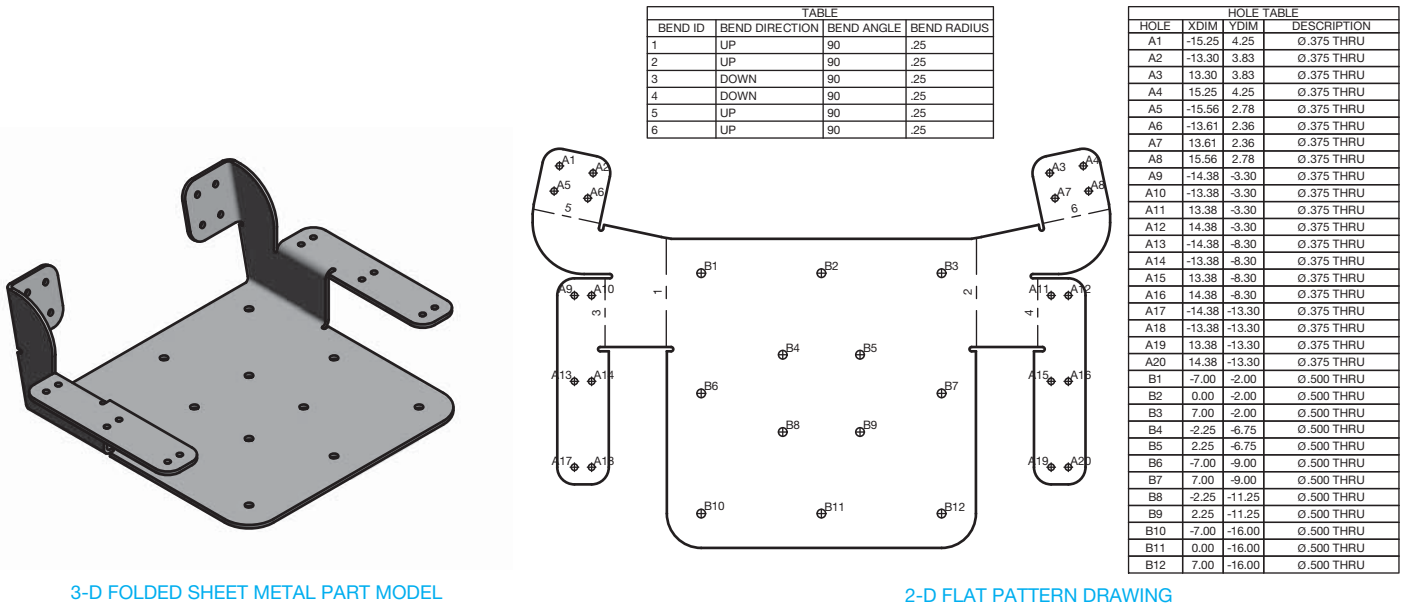
3-D FOLDED SHEET METAL PART MODEL



2-D FLAT PATTERN DRAWING

**FIGURE 19.8** A 3-D folded sheet metal part model and the related flat pattern drawing dimensioned using standard unidirectional dimensioning.

Courtesy Z-Kool, Inc.



**FIGURE 19.9** A sheet metal part model and flat pattern drawing with feature data extracted from the model to create a hole table and bend parameters extracted from the model to form a bend table.

intersection of the projected inside surfaces of a formed feature. The OML is a short, thin line segment representing the intersection of the projected outside surfaces of a formed feature. Not all of these characteristics are placed on every sheet metal model or sheet metal pattern drawing. The specific application depends on a company's standards and requirements.

### PRECISION SHEET METAL MATERIAL BENDING

In precision sheet metal applications, such as fabrication for electronics chassis components or sheet metal appliance and automotive body parts, the condition of material when bent must be taken into consideration. This consideration is called **bend allowance**. Bend allowance is the amount of extra material needed for a bend to compensate for the tension and compression during the bending process. When a material is bent, residual stresses cause it to spring back toward its original shape. Because of this, the material must be overbent to obtain the proper final bend. Bend allowance is important when close tolerances must be held or when thick material must be bent or formed into desired shapes. The purpose of a bend allowance calculation is to determine the overall dimension of the flat pattern, so the desired final dimension is achieved when the material is bent. The bend allowance can be calculated for any given situation, or it can be determined automatically using a CADD sheet metal modeling and flat pattern development program.

### Calculating Bend Allowance

A number of slightly different methods are used to calculate bend allowance. There are different formulas in the *Machinery's Handbook*, *ASME Handbook*, and in most textbooks. Many companies use formulas derived from a proven method or by

individual experimentation. The amount of bend allowance depends on:

- Material thickness.
- Type of material.
- Bending process.
- The dies or machine used.
- Bend angle.
- Bend radius.
- Grain of material.
- Surface condition.
- Amount of lubrication used.

The only exact way to establish bend allowance for a specific application is to experiment with the equipment and material to be used. Most companies extensively involved in material bending have made these tests and have developed charts that give the bend allowance for the type of material, material thickness, and bend radius. Use tested bend allowance charts when available.

When material bends, there is compression on the inside of the bend and stretching on the outside. Somewhere between is a **neutral zone** where neither stretching nor compression occurs. This neutral zone is called the **neutral axis**. The neutral axis is approximately four-tenths of the thickness from inside of the bend, but this depends on the material and other factors. Figure 19.11 provides information related to calculating the bend allowance and length of the flat pattern. Figure 19.11a shows the values and dimension variables for a 90° bend, and Figure 19.11b shows the values and dimension variables for a bend for any angle other than 90°.

The following formula is used to calculate the length of the flat pattern, which is the straight stock before bending for a 90° bend:

$$\begin{aligned} \text{Length of flat pattern} &= X + Y + Z \\ X &= \text{Horizontal dimension to bend} = B - R - C \\ Y &= \text{Vertical dimension to bend} = A - R - C \\ Z &= \text{Length of neutral axis} \end{aligned}$$

## PRECISION SHEET METAL DRAFTING AND DESIGN

The accuracy and clarity of drawings produced using CADD software is extremely beneficial for precision sheet metal design and drafting applications. CADD applications are available specifically for developing flat pattern layouts and converting existing drawings and models into flat patterns. These packages can automatically calculate bend allowances and notch locations based on material thickness and type

and the bend radius you enter. These applications should be confirmed with your company or school standards. The added advantage of many CADD systems is the ability to interface with CAM software, which allows information that is generated at the CADD workstation to be sent to the fabrication shop to run a computer numerical control (CNC) metal break or punch press. Figure 19.10 shows a 2-D drawing generated by a CADD precision sheet metal program.

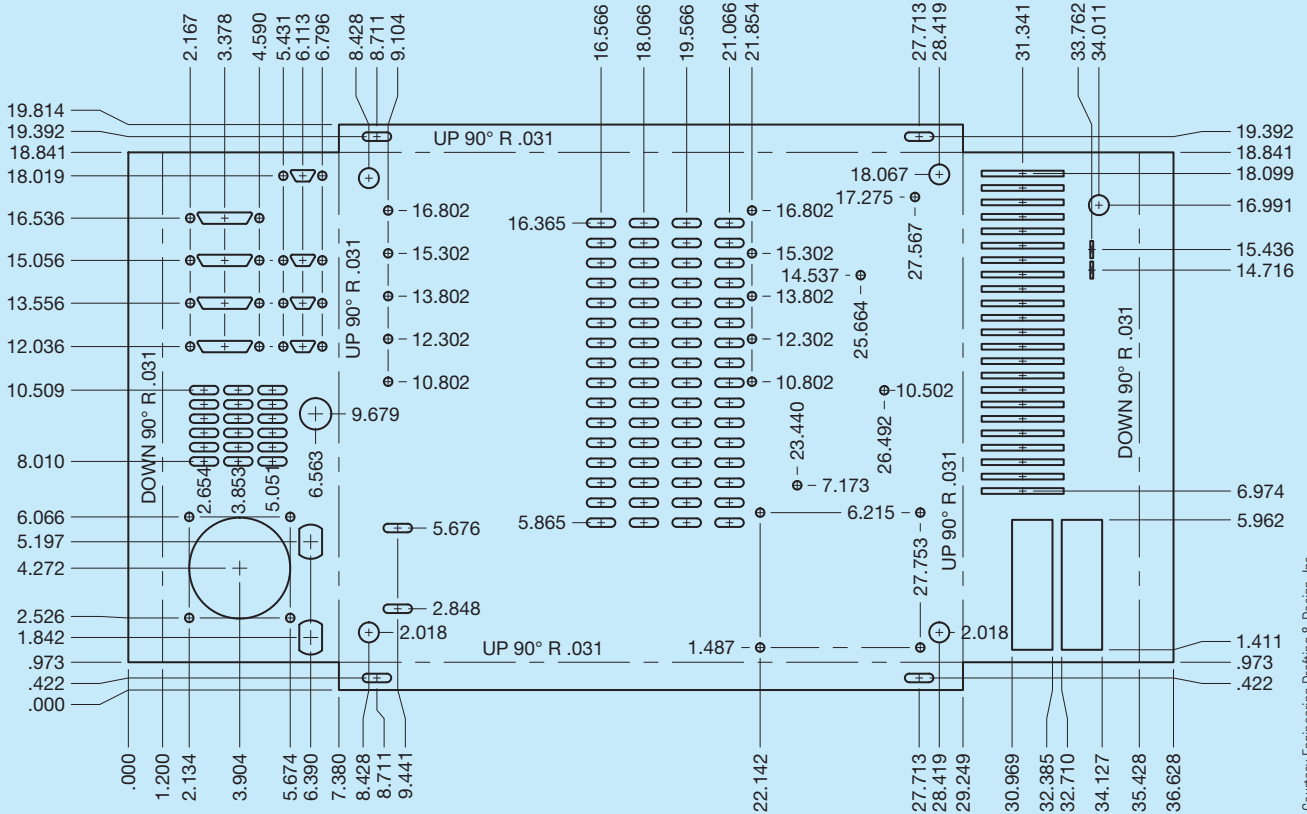


FIGURE 19.10 A 2-D drawing generated by a CADD precision sheet metal program.

Courtesy Engineering Drafting & Design, Inc.

- C = Material thickness
- R = Bend radius
- $Z = 2(R + .4C) \times \pi \div 4$  (90° bend)

The following formula is used to calculate the length of the flat pattern for a bend at any angle other than 90°:

- Length of flat pattern = X + Y + Z
- X = Horizontal dimension to bend = B - R - C
- Y = Vertical dimension to bend = A - R - C
- Z = Length of neutral axis
- C = Material thickness
- t = Dimension from inside face to neutral axis

This formula calculates  $t = .4C$ . This is a general calculation used in this textbook and will work for instructional purposes. The actual value depends on the variety of

characteristics that influence bend allowance as previously listed. The exact value for  $t$  needs to be determined by your company applications.

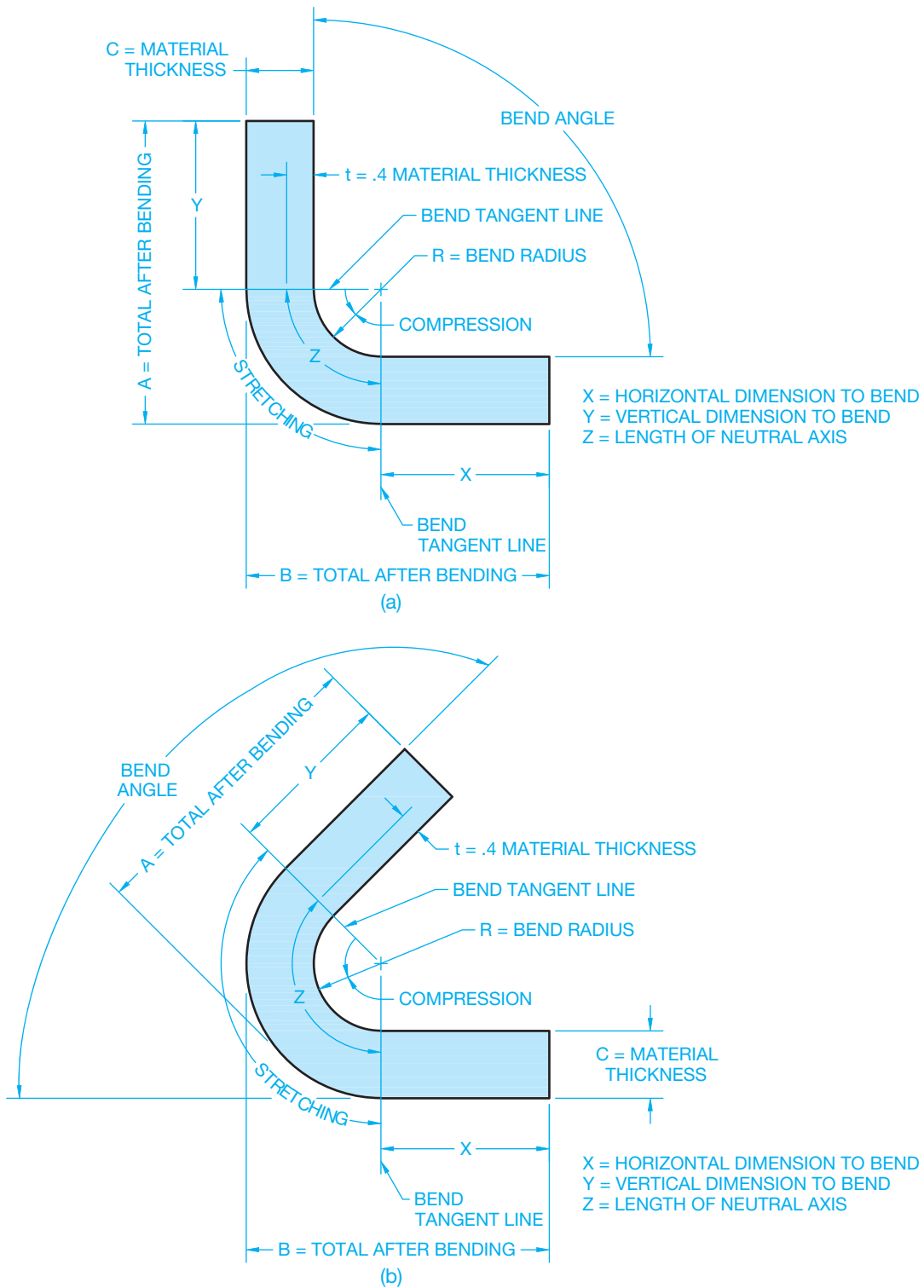
R = Bend radius

$$Z = [2(R + .4C) \times \pi \div 4] \times (\text{bend angle} \div 90) \text{ (angle other than } 90^\circ \text{ bend)}$$

Bend angle = degrees

$$K = (\text{K factor}) = t \div C$$

The **K factor** is a ratio of material thickness to the location of the neutral line after bending forces are applied. The K factor does not consider the forming stresses. Calculation of the K factor here is an approximation. The actual K factor value depends on the variety of characteristics that influence bend allowance



© Cengage Learning 2012

**FIGURE 19.11** (a) The values and dimension variables for a 90° bend. (b) The values and dimension variables for a bend for any angle other than 90°.

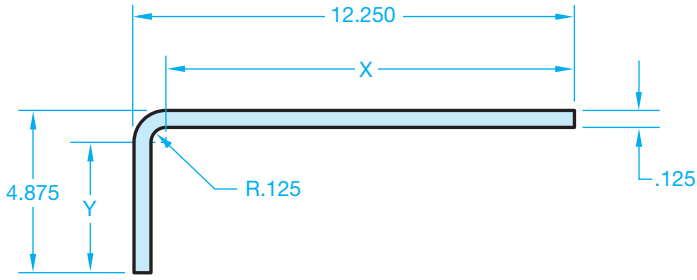


FIGURE 19.12 Sample bend allowance problem. © Cengage Learning 2012

as previously listed. When using the K factor to calculate bend allowance, your company will probably have tables for you to use that are created to characterize the specific material, bend angle, bend radius, and bending process used at the company.

$$Z = \text{Bend angle}(\pi \div 180) (R + K \times C)$$

### Example Bend Allowance Calculation

Given the sheet metal bend shown in Figure 19.12, determine the length of the flat pattern.

$$X = B - R - C = 12.250 - .125 - .125 = 12.000$$

$$Y = A - R - C = 4.875 - .125 - .125 = 4.625$$

$$Z = 2(R + .4C) \times \pi \div 4 = 2(.125 + .4 \times .125) \times 3.14 \div 4 = .275$$

$$\text{Length of Flat Pattern} = X + Y + Z = 12.000 + 4.625 + .275 = 16.900$$

### Multiple Bends

The examples in Figure 19.11 and 19.12 show a single bend. Most sheet metal products require several bends. Any number of bends is possible based on the design requirements. Figure 19.13 shows common examples of using two bends to form a sheet metal part that connects two parallel surfaces, or faces. Some sheet metal CADD systems refer to this formation, or process, as a **double bend**. A double bend is a bend between two parallel faces that are not **coplanar**. The term **coplanar** means flat surfaces lying on the same plane.

### Bend Transition

The **bend transition** is especially important for bending across complex shapes to ensure manufacturability. Bend transition refers to the change made between the adjacent surfaces at a bend when the edge of one surface extends beyond the edge of the other surface. Figure 19.14 shows different bend transition options. The transition between the surfaces can be curved as in a **spline** shape, a radius, or straight, depending on the desired result and capabilities of the manufacturing equipment to produce the design. A spline is a smooth curve that runs through a series of points.

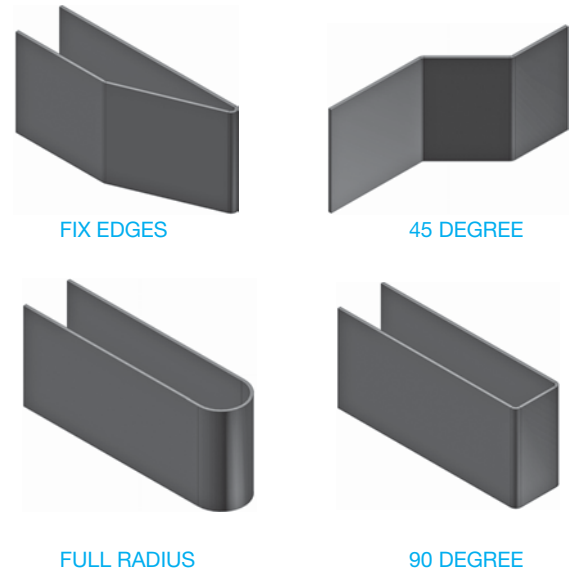


FIGURE 19.13 A variety of common double bend options.

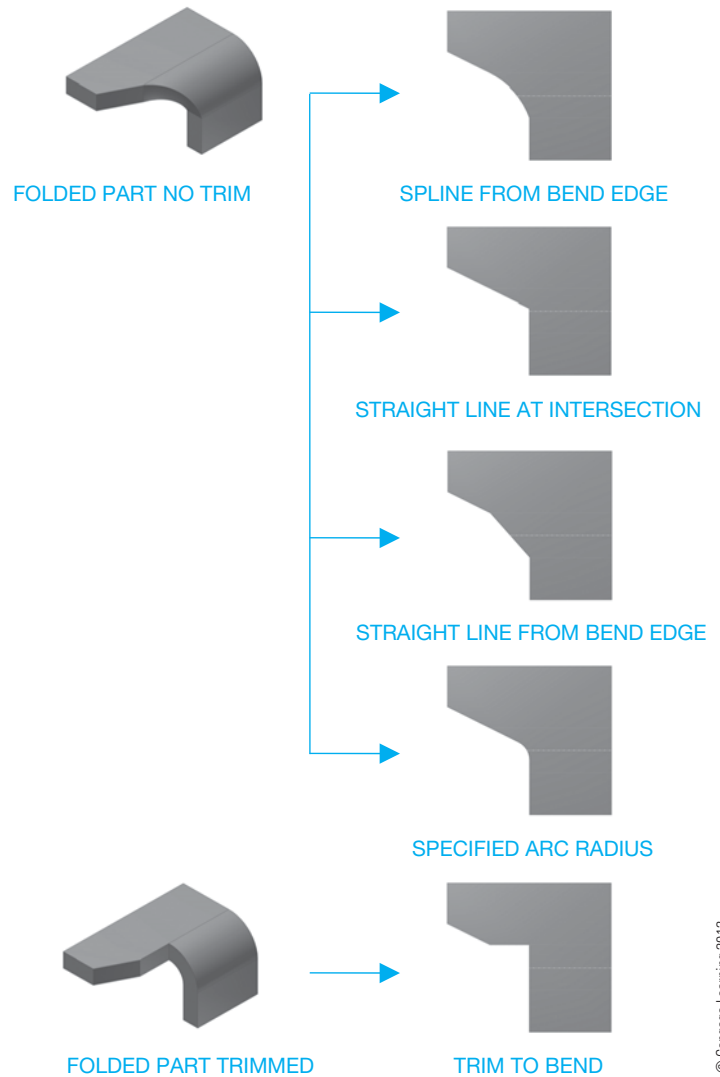


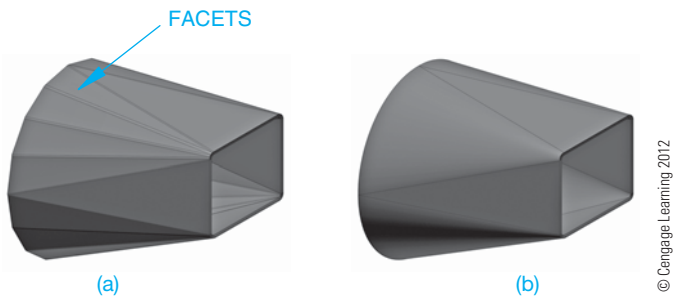
FIGURE 19.14 The effects of selecting different bend transition options.



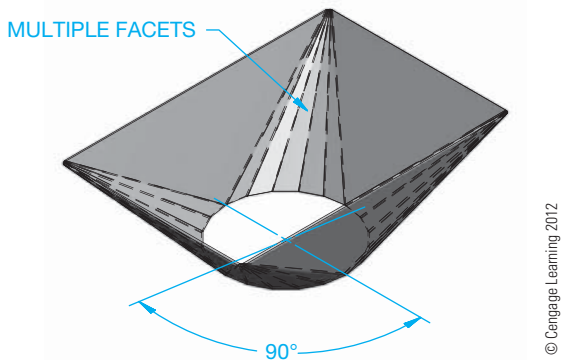
## Bending a Corner to a Round

Depending on the manufacturing process, when a sheet metal part makes a transition from a square or rectangular shape to a round shape, a series of bends, or **bend facets**, may be required to form the change in shape. Bend facets are a series of flat triangular planes that create a curve when making a transition from a corner to a radius or circle (see Figure 19.15a). A sheet metal part that makes a transition from square or rectangular to round is commonly known in HVAC sheet metal design as a **transition piece**. Bend facets are used when the sheet metal part is formed using a **press break** as shown in Figure 19.15a. A press break is a machine tool used to make bends in sheet metal. The contour between the corner and the arc or circle can be smooth when the shape is formed in a **die**, as shown in Figure 19.15b. The term *die*, used in this application, refers to a machine tool used to press or form sheet metal into the desired shape.

When designing a sheet metal part with bend facets for a press break application, the arc is divided into a number of equal parts, and each part on the arc is connected to the corner, forming a series of triangular facets. When designing a square or rectangular shape to round sheet metal parts, the circle is divided into equal parts and the parts in each 90° quarter are connected to the adjacent corner as shown in Figure 19.16. Twelve is a common number of equal parts used when dividing the circle



**FIGURE 19.15** (a) Bend facets are used when the sheet metal part is formed using a press break. (b) The contour between the corner and the arc or circle can be smooth when the shape is formed in a die.

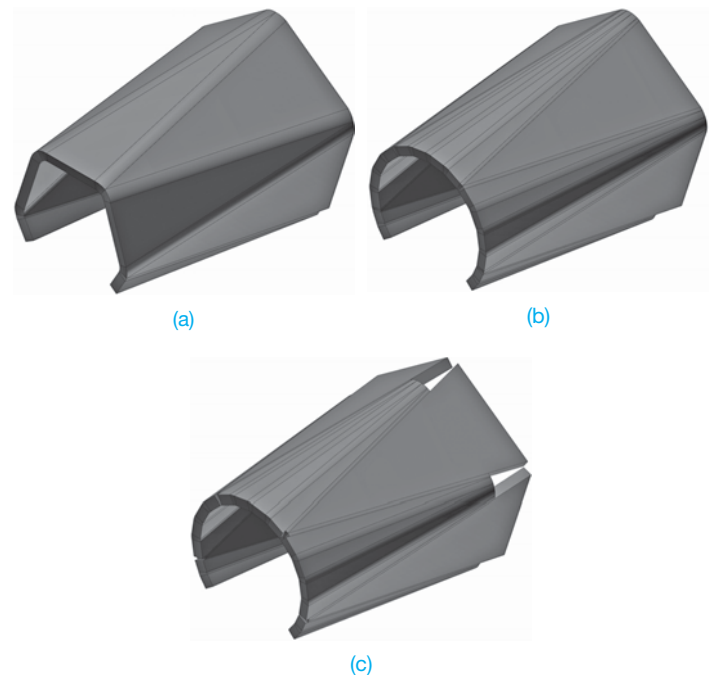


**FIGURE 19.16** When designing a square or rectangular to round sheet metal part, the circle is divided into equal parts, and the part in each 90° quarter is connected to the adjacent corner.

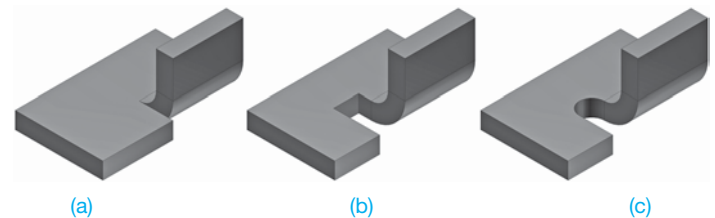
for establishing the bend facets. A circle divided into 12 equal parts makes each part 30° ( $360^\circ \div 12 = 30^\circ$ ). It is often desirable to form a sharper corner by decreasing the number and size of the bend facets as shown in Figure 19.17.

## Bend and Corner Relief

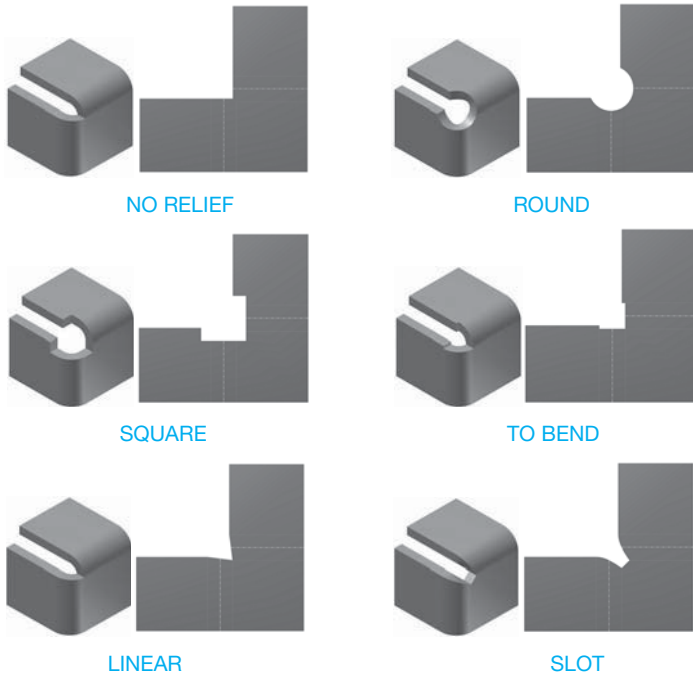
**Bend relief** is typically added to a sheet metal part to relieve stress or to prevent the tear that occurs when a portion of a piece of material is bent. Bend relief can be applied to a variety of situations. A common application occurs when a portion of the sheet metal part is bent next to a flat unbent surface as shown in Figure 19.18. Figure 19.18a demonstrates the tear that occurs when no bend relief is used. Figure 19.18b shows a straight bend relief used where the bent surface meets the flat surface. Figure 19.18c shows a round bend relief used where the bent surface meets the flat surface.



**FIGURE 19.17** It is often desirable to form a sharper corner by decreasing the number and size of the bend facets. (a) Few bend facets. (b) Several bend facets. (c) Trimming intersecting bend facets. © Cengage Learning 2012



**FIGURE 19.18** Bend relief examples. (a) The tear that occurs when no bend relief is used. (b) A straight bend relief used where the bent surface meets the flat surface. (c) A round bend relief used where the bent surface meets the flat surface. © Cengage Learning 2012



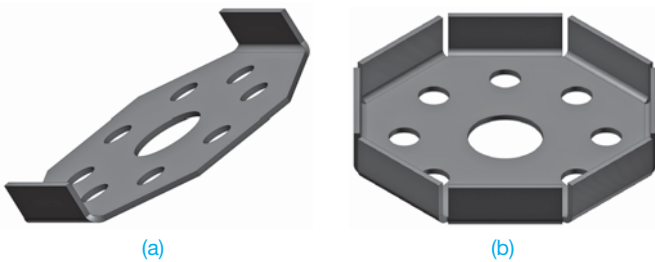
**FIGURE 19.19** A variety of corner relief options that can be used in sheet metal part design. © Cengage Learning 2012

**Corner relief** is used to cut away material at a corner to relieve stress and help in the forming process. A corner with two or more edges bent in the same direction has internal stresses that can cause a crack at the corner and interference when bending. Figure 19.19 shows a variety of corner relief options that can be used in sheet metal part design.

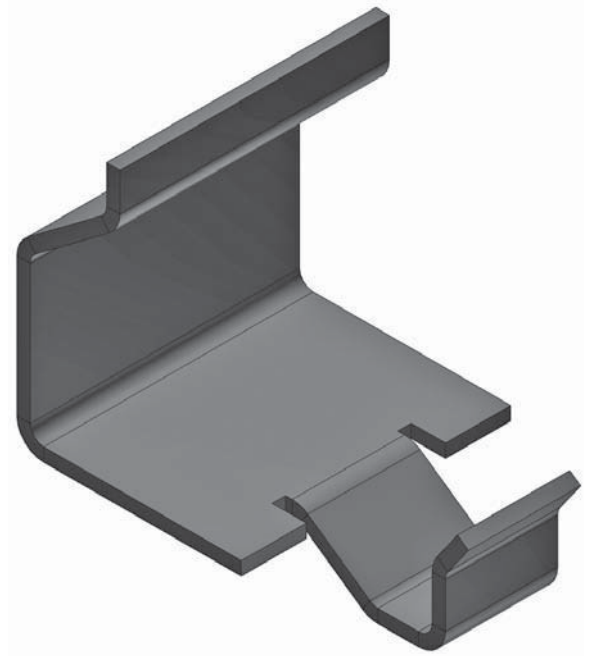
**FLANGES**

A **flange** is a feature added to a sheet metal part to reinforce or stiffen a part edge or to provide a surface for fastening or welding. Figure 19.20 shows an example of a flange added to two edges on a sheet metal part and the use of multiple flanges. Intersecting flange corners are designed using bend and corner relief previously described.

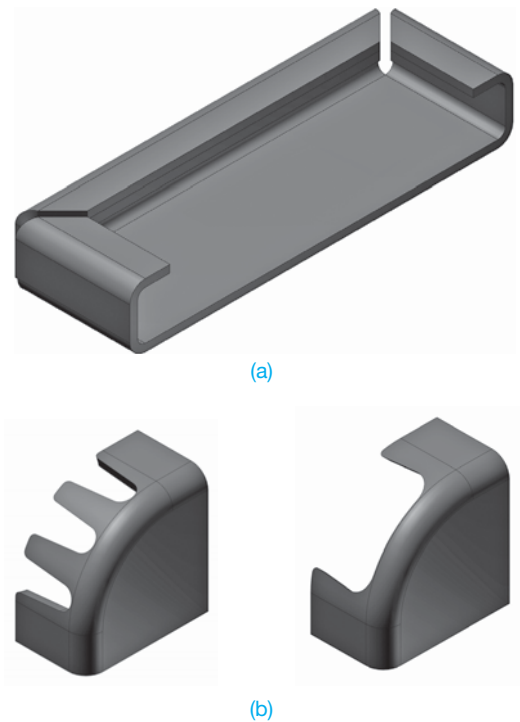
A **contour flange** is a sheet metal feature that uses an open profile to create linear sheet metal fabrications. Contour flanges are often used on sheet metal features such as channels, corrugated panels, and cabinet frames. Figure 19.21 shows the



**FIGURE 19.20** (a) An example of a flange added to two edges on a sheet metal part. (b) The use of multiple flanges. © Cengage Learning 2012



**FIGURE 19.21** The addition of a contour flange along the single edge of a sheet metal part. © Cengage Learning 2012



**FIGURE 19.22** (a) When the sheet metal part design requires contour flanges to continue around the part, the corners are mitered to create a continuous feature. (b) A notched corner can be used when a flange continues around a corner. © Cengage Learning 2012

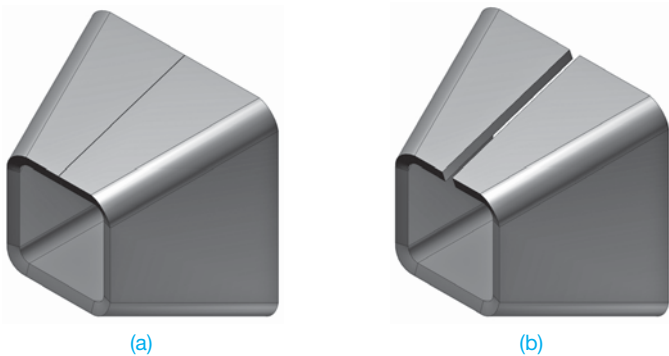
addition of a contour flange along the single edge of a sheet metal part. When the sheet metal part design requires contour flanges to continue around the part, the corners are **mitered** to create a continuous feature as shown in Figure 19.22a. A **miter**

is also called a **miter joint**, which is a joint that forms a corner. A miter joint usually has both sides beveled at a 45° angle to form a 90° corner. The miter can be any angle, but it is usually half the total angle, making both bevels equal angles. A notched corner can be used when a flange continues around a corner as shown in Figure 19.22b.

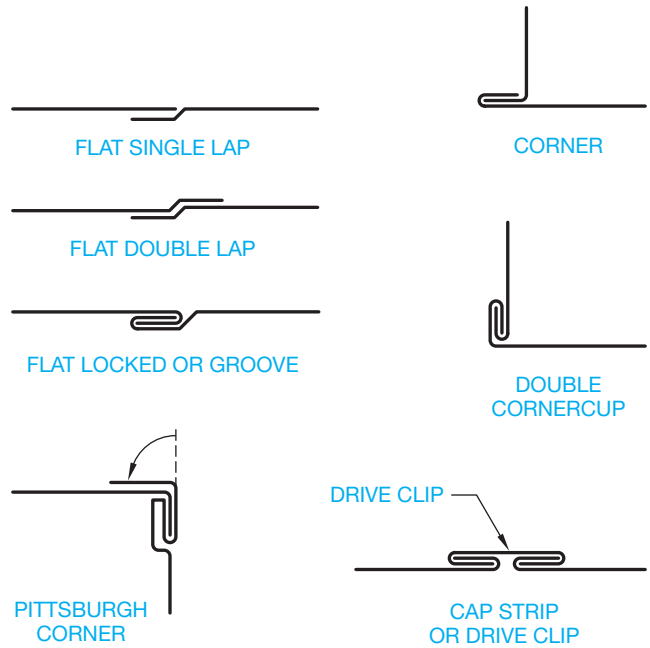
## SEAMS AND HEMS

A **seam** is the line or opening formed when the ends of the sheet metal pattern come together when developed. The type of seam used depends on the fabrication process. A seam can be a tight butt joint where the pattern edges come together as shown in Figure 19.23a. A specific gap can also be used for welding or other fabrication processes as shown in Figure 19.23b. Chapter 18, *Welding Processes and Representations*, describes welding processes and specifications applied to sheet metal fabrication. The fastening method depends on the kind and thickness of material, on the fabrication processes available, and on the end use of the part. Sheet metal components that must hold gas or liquid or are pressurized can require soldering, brazing, or welding. Other applications use mechanical seams, which hold the parts together by pressure-lapped metal, metal clips, pop rivets, or other fasteners. Figure 19.24 shows some of the most common seams used in the sheet metal fabrication industry. Extra material can be required on the pattern to allow for seaming. A **single-lap seam** adds a given amount of material to one side of the pattern. A **double-lap seam** adds a given amount of material to both sides of the pattern. The corner of a seam can be cut off at an angle that is usually 45° if it interferes with adjacent parts during fastening.

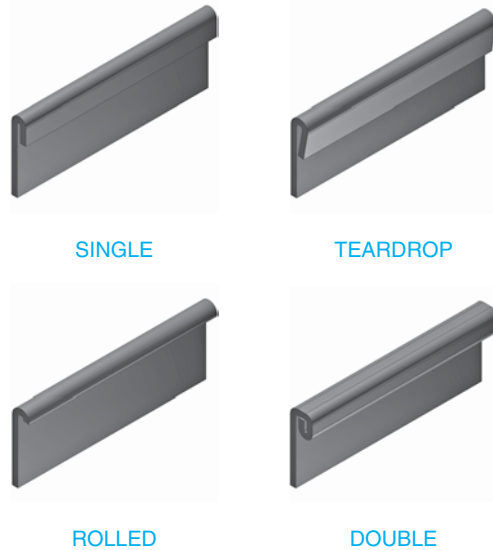
A **hem** is a flange used to add strength to or relieve the sharpness of exposed edges or to connect separate edges or parts together at a seam. Hemmed edges are necessary when an exposed edge of a pattern must be strengthened. When hems are used, extra material must be added to the pattern on the side of the hem. Figure 19.25 shows some common hems.



**FIGURE 19.23** (a) A seam can be a tight butt joint where the pattern edges come together. (b) A specific gap can also be used for welding or other fabrication processes. © Cengage Learning 2012



**FIGURE 19.24** Some of the most common seams used in the sheet metal fabrication industry.



**FIGURE 19.25** Common hems.

## ROLL FORMING

A **roll form** is a sheet metal feature that creates a curved sheet metal feature in a linear application on flat material or around an axis. A roll form is appropriate for flat or cylindrical applications such as rolled surfaces, contoured rolls, beads, or other similar features. Roll forming is commonly applied to the curvature of aircraft stringers and frames, column wraps, and automotive body panels. A roll form is defined by the location of a centerline and a radius dimension. Figure 19.26 shows a linear and contour roll form.

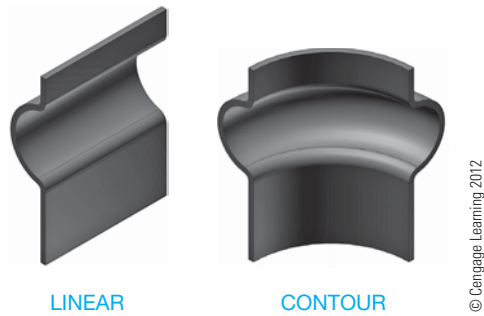


FIGURE 19.26 A linear and contour roll form.

## LANCING

**Lancing** is a stamping press operation that forms a single-line cut partway across the sheet without removing material. Lancing is done to free metal for forming as shown in Figure 19.27a. Lancing can also be used to form features such as louvers as shown in Figure 19.27b.

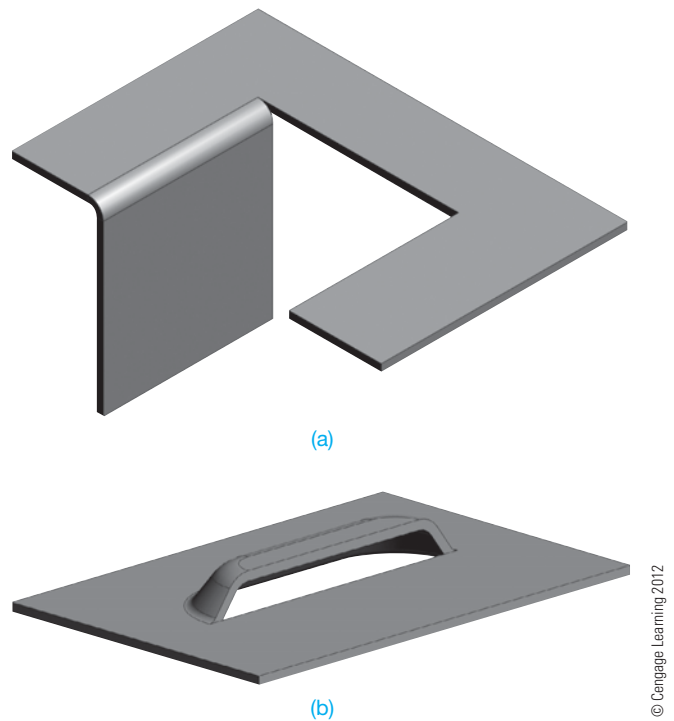


FIGURE 19.27 (a) Lancing is done to free metal for forming. (b) Lancing can also be used to form features such as louvers.

## SHEET METAL MODELING

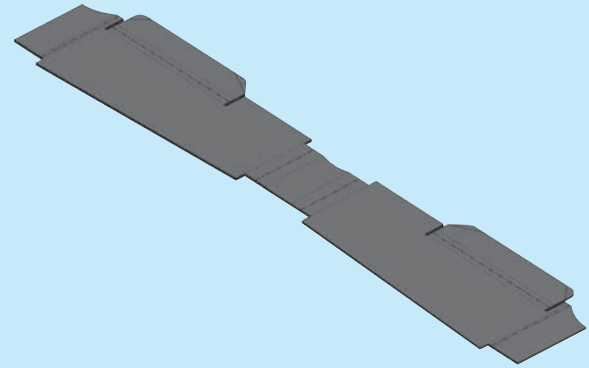
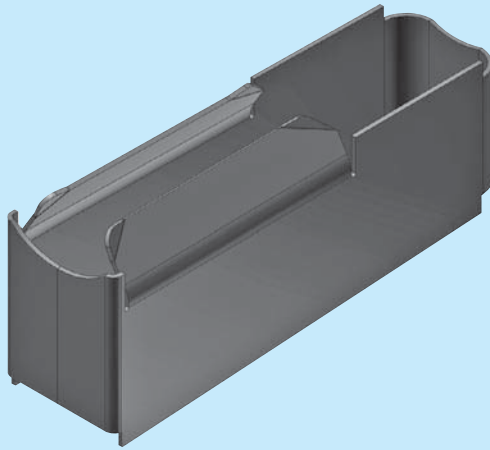
Most 3-D CADD software packages can be used to develop sheet metal models. However, some programs have specific sheet metal tools available for building sheet metal parts and precision sheet metal patterns. Modeling a sheet metal part using feature-based 3-D solid modeling software is similar to modeling a non-sheet metal part. Usually you begin with a 2-D or 3-D sketch, although a 2-D sketch is most common. Use the same sketching tools and techniques you use to prepare a non-sheet metal part sketch. You then create a sheet metal-sketched base feature, followed by adding sketched, placed, and catalog features as needed. Most often, you build a sheet metal part in a finished, folded form that you can unfold to create a flat pattern.

A sheet metal part forms from a single piece of material according to parameters appropriate for the material, part, and manufacturing process. Some specialized 3-D sheet metal CADD systems accommodate this requirement by providing tools and options that reference several sheet metal specifications in addition to color and lighting. These parameters, or rules, set by styles and standards, include metal thickness, material, bend specifications, relief sizes, and unfold options. For most applications, sheet metal rules remain the same throughout part construction and automatically apply as you design. This

technique replicates real-world sheet metal part manufacturing by forming parts using a specific type of sheet metal and sheet metal rules. Sheet metal rules also control how flat patterns appear. Use sheet metal styles appropriate for the material, part, and manufacturing process. For example, use a style assigned .0478" (18 gage) steel attributes for an 18 gage steel part. If the design changes, requiring the part to be .0453" (17 gage) aluminum, for example, change the part to reference a style with those attributes. The part automatically updates according to the new parameters.

After you establish sheet metal parameters, you can use a variety of tools to prepare a sheet metal part, including features such as flanges, hems, holes, bends, and punches. Figure 19.28 shows an example of a 3-D sheet metal part model created using specialized sheet metal tools and options. Once you create a sheet metal part, or anytime during sheet metal model development, you can unfold the part and create a sheet metal pattern. Unfolding a sheet metal part is often as easy as picking a single button, depending on the software program. The pattern tool calculates all the features and bends in the part and creates a flat pattern. A sheet metal pattern can exist in the modeling environment as shown in Figure 19.29, or it can be accessed in a drawing and fully detailed (see Figure 19.30).

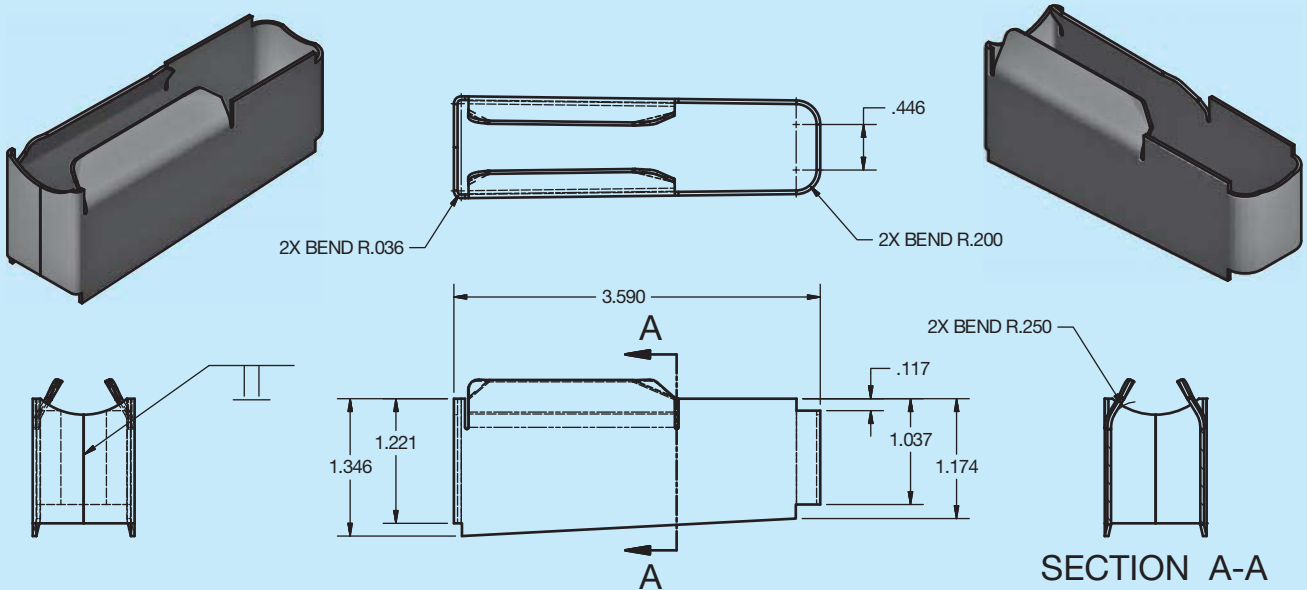
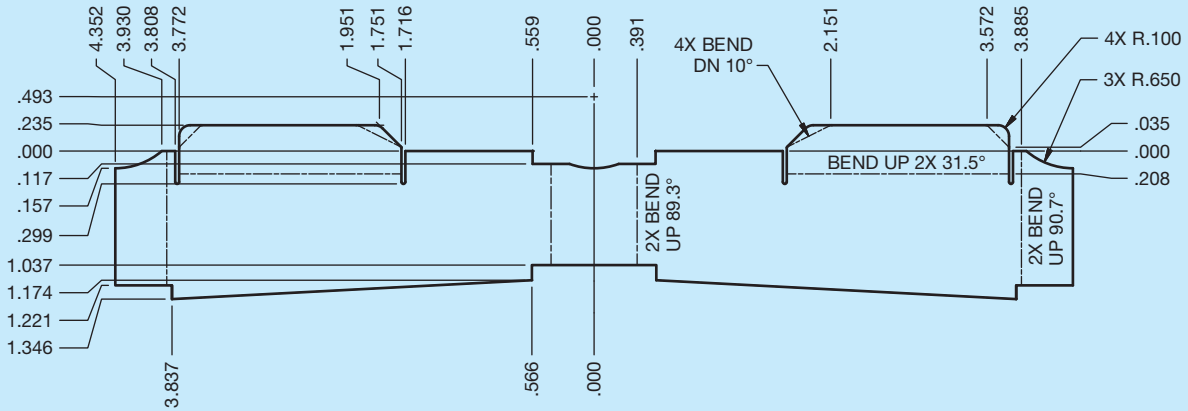
(Continued)



© Cengage Learning 2012

**FIGURE 19.29** A sheet metal pattern can exist in the modeling environment.

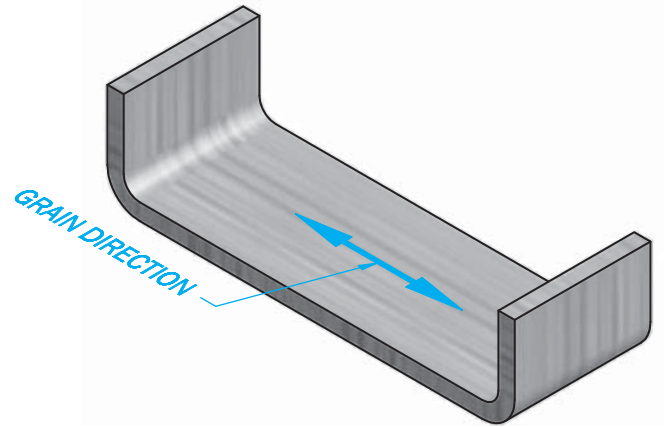
**FIGURE 19.28** An example of a 3-D solid sheet metal part model created using specialized sheet metal tools and options. © Cengage Learning 2012



**FIGURE 19.30** A sheet metal pattern can exist in the modeling environment as shown in Figure 19.29, or it can be accessed in a drawing and fully detailed as shown here. © Cengage Learning 2012

## MATERIAL APPLICATIONS IN SHEET METAL DRAFTING

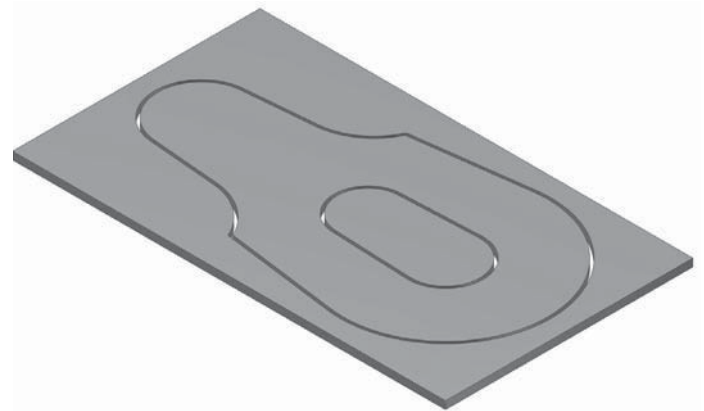
In some applications, it is necessary to take into consideration the grain of the material when forming sheet metal parts. **Metal grain** is the predominant direction of the crystals in the metal. When designing highly stressed parts, it can be important to consider the grain structure when the material is shaped into the desired form. Notice in Figure 19.31 that the grain structure of the formed material remains parallel to the contour of the part. Often the best bend orientation is to have the grain direction perpendicular to the bend as shown in Figure 19.32. This minimizes the chances of cracking on the outer radius. It is not always possible to have the grain structure perpendicular to the bend due to economical reasons to reduce waste, aesthetic reasons to match other parts, or for strength reasons due to loading direction. The engineer or architect generally confirms grain structure requirements.



**FIGURE 19.32** The best grain structure is to have the grain direction perpendicular to the bend. © Cengage Learning 2012

### Blanking

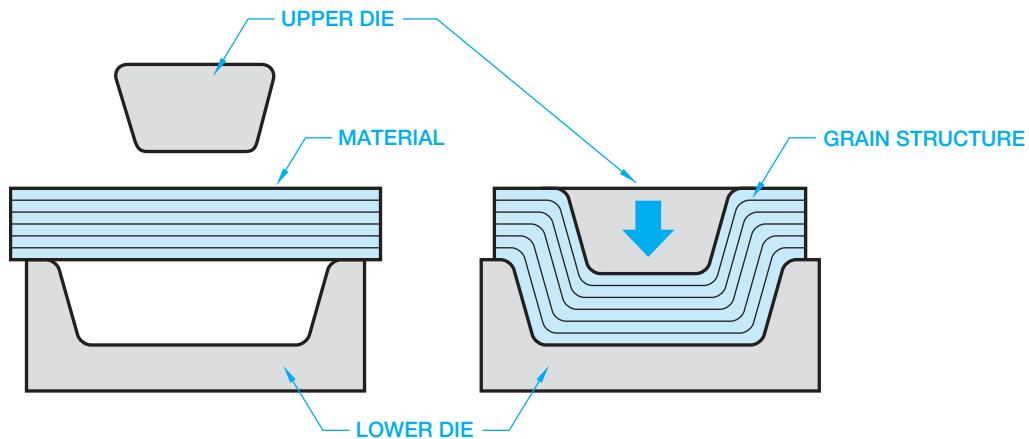
**Blanking** is the process of producing a sheet metal part by cutting its entire outside edge in a die with one stroke of the **stamping press**. A stamping press is a metalworking machine tool used to shape or cut metal by deforming it with a die. The best results are achieved by the part fitting on the sheet with the least amount of wasted material. Figure 19.33 shows a basic blank.



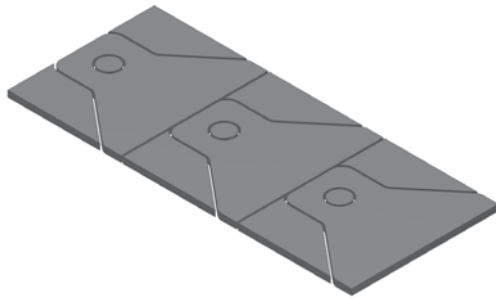
**FIGURE 19.33** A basic blank. © Cengage Learning 2012

### Nesting Blanks

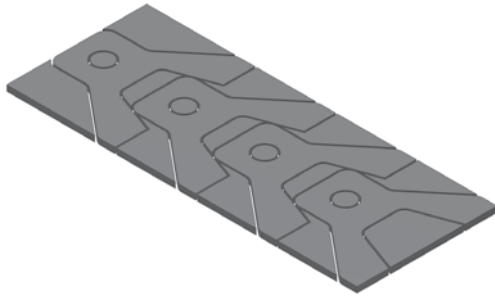
A common design consideration in the manufacture of sheet metal parts is **nesting blanks**. Nesting blanks is the arrangement of sheet metal patterns on sheet stock to minimize scrap during the stamping process. Figure 19.34 shows nesting blanks in an effort to reduce scrap during the stamping process. Design



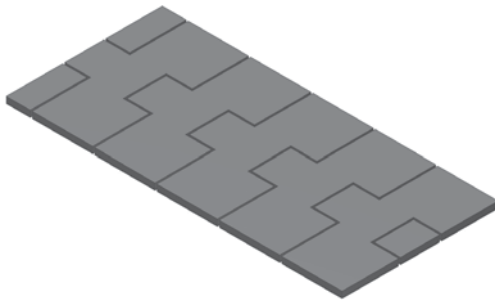
**FIGURE 19.31** When designing highly stressed parts, it can be important to consider the grain structure when the material is shaped into the desired form, and in the process, the material retains its original grain structure. Notice here that the grain structure of the formed material remains parallel to the contour of the part. © Cengage Learning 2012



HIGH PERCENTAGE OF SCRAP



REDUCED SCRAP



MINIMUM SCRAP

© Cengage Learning 2012

**FIGURE 19.34** Nesting blanks in an effort to reduce scrap during the stamping process.

changes may be required to help reduce scrap when nesting blanks. In some situations, it can be necessary to stamp an individual blank or combine as few as two or three parts to help reduce scrap.

## PRECISION SHEET METAL DIMENSIONING APPLICATIONS

The beginning of this chapter introduces common dimensioning applications related to the options for drawing precision sheet metal part models and patterns. Precision sheet metal parts are generally dimensioned using standard baseline dimensioning, rectangular coordinate dimensioning without dimension lines, or tabular dimensioning. Review Chapter 10, *Dimensioning and Tolerancing*, for more information on standard dimensioning practices. In addition to the typical dimensioning systems used in precision sheet metal drafting, sheet metal parts normally have features such as rounded corners,

holes, and slots. Multiple features are also common. These features are dimensioned in the same manner as described in Chapter 10.

### STANDARDS

**ASME** The standard ASME Y14.31-2008, *Undimensioned Drawings*, provides the requirements for undimensioned drawings that graphically define objects with true geometry views and predominantly without dimensions. Many of the terms used in this chapter are defined and represented in this standard.

## Undimensioned Drawings

**Undimensioned drawings** are engineering drawings that are created to an exact scale from which the designed part and associated tooling are produced directly by photographic or other processes. An advantage of the undimensioned drawing is that the CAD model can be sent directly to the CAM machine tool for fabrication. Objects are generally drawn full scale, but they can be drawn at a larger scale to define specific detail or smaller scale as needed. Drawings created at a scale other than full scale are typically returned to full scale before manufacturing. Undimensioned drawings provide dimensional characteristics graphically rather than using traditional dimensioning practices. Undimensioned drawings can display dimensions with values when needed to establish specific features, nominal values, and tolerances, and to verify material stability. Dimensions are used when feature sizes and locations have tolerances that are different from those applied to standard undimensioned feature tolerances given in the title block or in general notes.

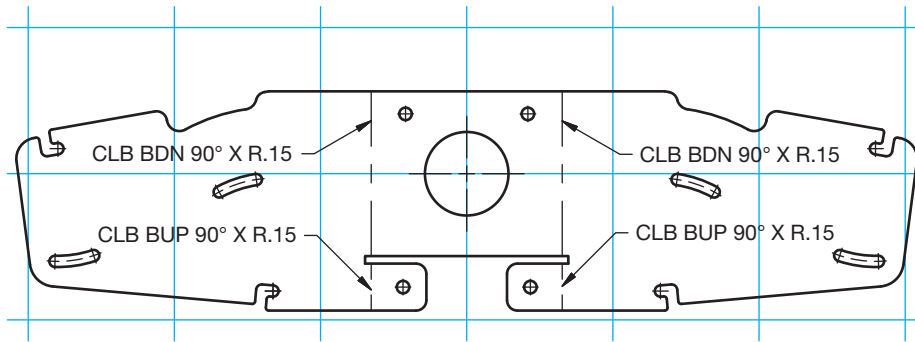
An example of a common undimensioned drawing is a sheet metal pattern in which the given drawing without dimensions is used exactly as drawn to duplicate the flat pattern before bending. Another specific application is the accurate layout of **templates** for contours and sheet metal profiles and the accurate layout of parts that have a large number of features such as electronic chassis layout. A template used in this application is a dimensionally stable tool that is a full-size reproduction defining the true profile of the part. Undimensioned drawings have other applications as described when appropriate in this textbook.

## Dimensional Accuracy Applications

Specific methods are used to establish the accuracy of undimensioned drawings. It is necessary to use one of these accuracy verification methods because actual dimensions are not given for confirmation. The accuracy verification can be done using grid lines, dimensional accuracy points, or registration marks.

### Grid Lines

**Grid lines** are a pattern of thin, equally spaced perpendicular lines drawn at an exact scale across the face of the drawing to confirm dimensional accuracy as shown in Figure 19.35. Grid



## NOTES:

1. GRID LINES 5 IN ON CENTER.
2. FOR MANUFACTURING PURPOSES, THIS DRAWING SHALL BE REPRODUCED ON STABLE BASE MATERIAL.

**FIGURE 19.35** Grid lines are a pattern of thin, equally spaced perpendicular lines drawn at an exact scale across the face of the drawing to confirm dimensional accuracy.

Courtesy 2-Kool, Inc.

lines should be placed on their own layer. The grid spacing depends on the size of the drawing, but common spacing is 5 in. (127 mm) or 10 in. (254 mm). A note is placed on the drawing identifying the grid line spacing, such as GRID LINES 5.000 (127 mm) ON CENTER. The grid lines can be parallel to the drawing border or rotated as needed for the specific drawing. Dimensional accuracy points are required to confirm accuracy when grid lines are rotated. A portion of the grid lines pattern can be removed if necessary for view clarity, but an approximate minimum of 1 in. (25 mm) diameter should be kept at the grid intersection.

## Dimensional Accuracy Points

**Dimensional accuracy points** are a set of points located in a rectangular pattern surrounding the object and within the drawing border to establish a means of dimensioning horizontally, vertically, or diagonally across a drawing to validate dimensional accuracy. A minimum of four dimensional accuracy points are used on a drawing. Six dimensional accuracy points are used when the limits of the drawing exceed the ability of the verification process. The horizontal and vertical locations of the dimensional accuracy points are controlled directly or with a reference. When the accuracy points are controlled directly, extend a line capped with arrowheads horizontally and vertically from one of the points. A dimension is placed on each line, giving the dimensions to the adjacent dimensional accuracy points on the drawing. When six points are used, the center point has 3-D line segments with dimension values to the adjacent points. Figure 19.36a shows a drawing using dimensional accuracy points. Figure 19.36b shows different dimensional accuracy point options.

## Registration Marks

**Registration marks** can be used for artwork alignment in place of grid lines. A minimum of three registration marks are placed in a right triangle pattern surrounding the drawing

view or artwork. Registration marks are commonly used on printed circuit drawings as described in Chapter 20, *Electrical and Electronic Drafting*. When a drawing must be reduced to a final size for fabrication, the final dimensions are placed between the registration marks to indicate the reduction. Figure 19.37a shows a drawing using registration marks, and Figure 19.37b shows the different registration mark symbols that can be used.

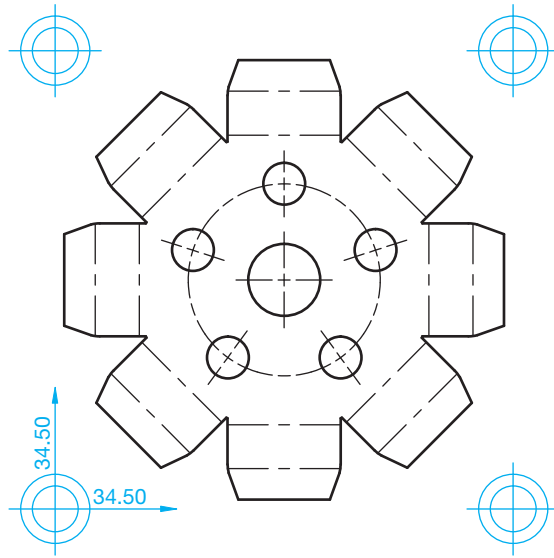
## Media Used for Undimensioned Drawings

The stability of the drawing media is important when preparing undimensioned drawings. Drawing requiring strength, durability, and dimensional stability should be prepared on class 1 polyester film in accordance with document L-P-519, *Plastic Sheet, Tracing, Glazed, and Matte Finish*, listed in the Department of Defense Index of Specifications and Standards (DoDISS). Reproductions that require accuracy are prepared on class 3 polyester film. All undimensioned drawings should have this general note: FOR MANUFACTURING PURPOSES, THIS DRAWING SHALL BE REPRODUCED ON STABLE MATERIAL.

## Undimensioned Drawing Tolerances

The features of the objects on an undimensioned drawing should be drawn with actual size and location tolerances of  $\pm 0.10$  in. (0.25 mm). The contour definitions on drawings, such as templates, are provided to true profile. The tolerance of each grid line cell is  $\pm 0.005$  in. (0.13 mm), and the total grid tolerance is  $\pm 0.10$  in. (0.25 mm). The tolerance for the location of dimensional accuracy points is  $\pm 0.10$  in. (0.25 mm). The tolerance for the location of registration marks is  $\pm 0.005$  in. (0.13 mm).

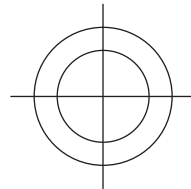




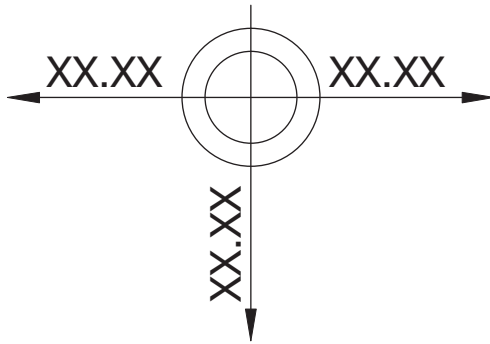
**NOTE:**

1. FOR MANUFACTURING PURPOSES, THIS DRAWING SHALL BE REPRODUCED ON STABLE BASE MATERIAL.

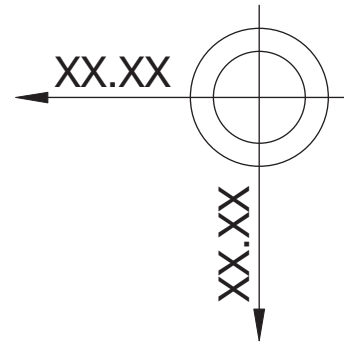
(a)



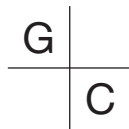
TRAMMEL POINT



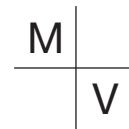
CENTER DIMENSIONAL TRAMMEL POINT



DIMENSIONAL TRAMMEL POINT



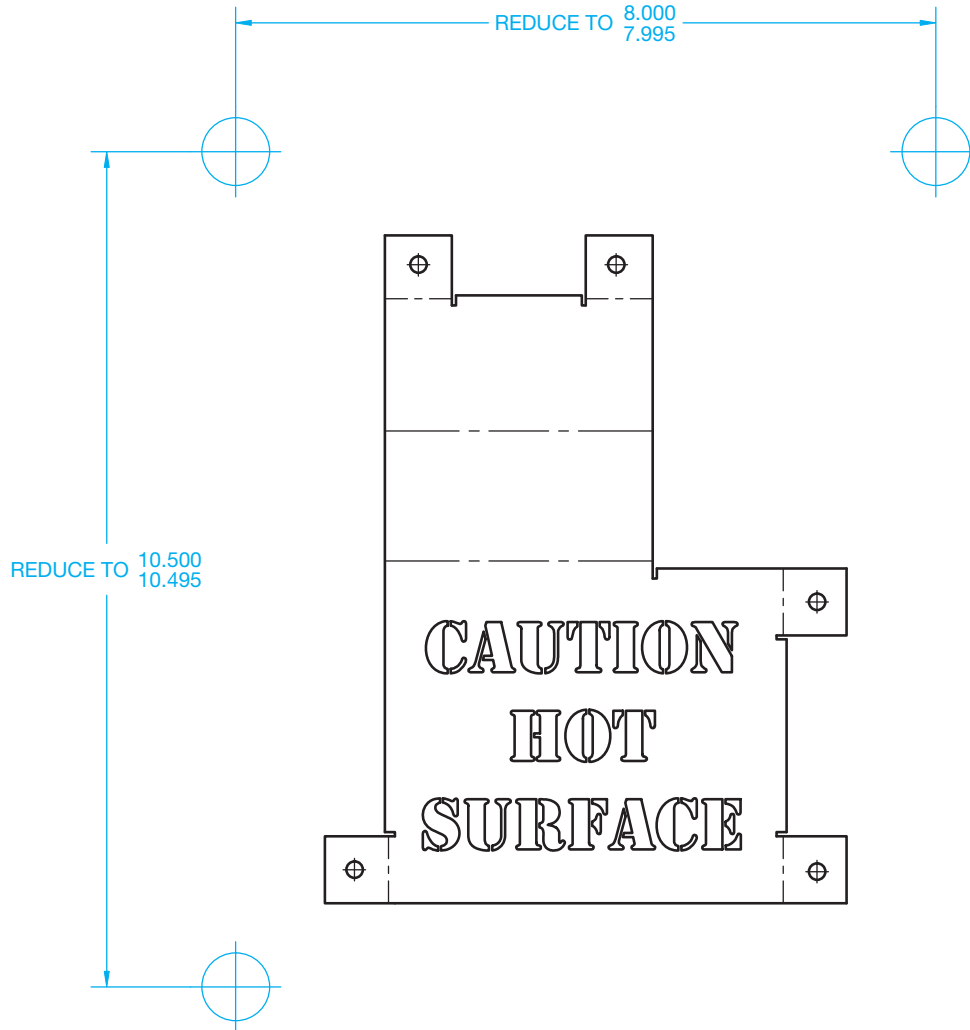
GRID CHECK POINT



MATERIAL VALIDATION POINT

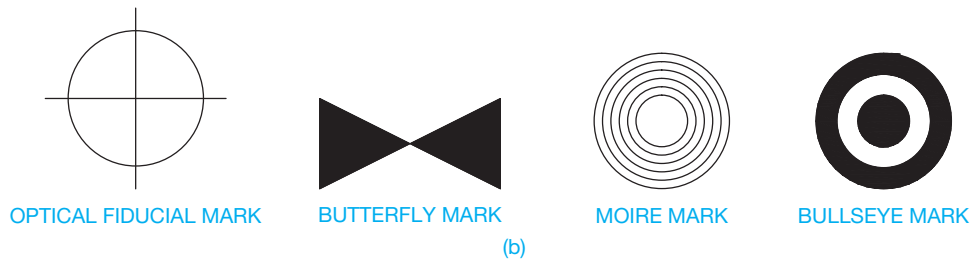
(b)

**FIGURE 19.36** (a) A drawing using dimensional accuracy points. (b) The different dimensional accuracy point options that can be used.



**NOTE:**  
 1. FOR MANUFACTURING PURPOSES, THIS DRAWING SHALL BE REPRODUCED ON STABLE BASE MATERIAL.

(a)



(b)

© Cengage Learning 2012

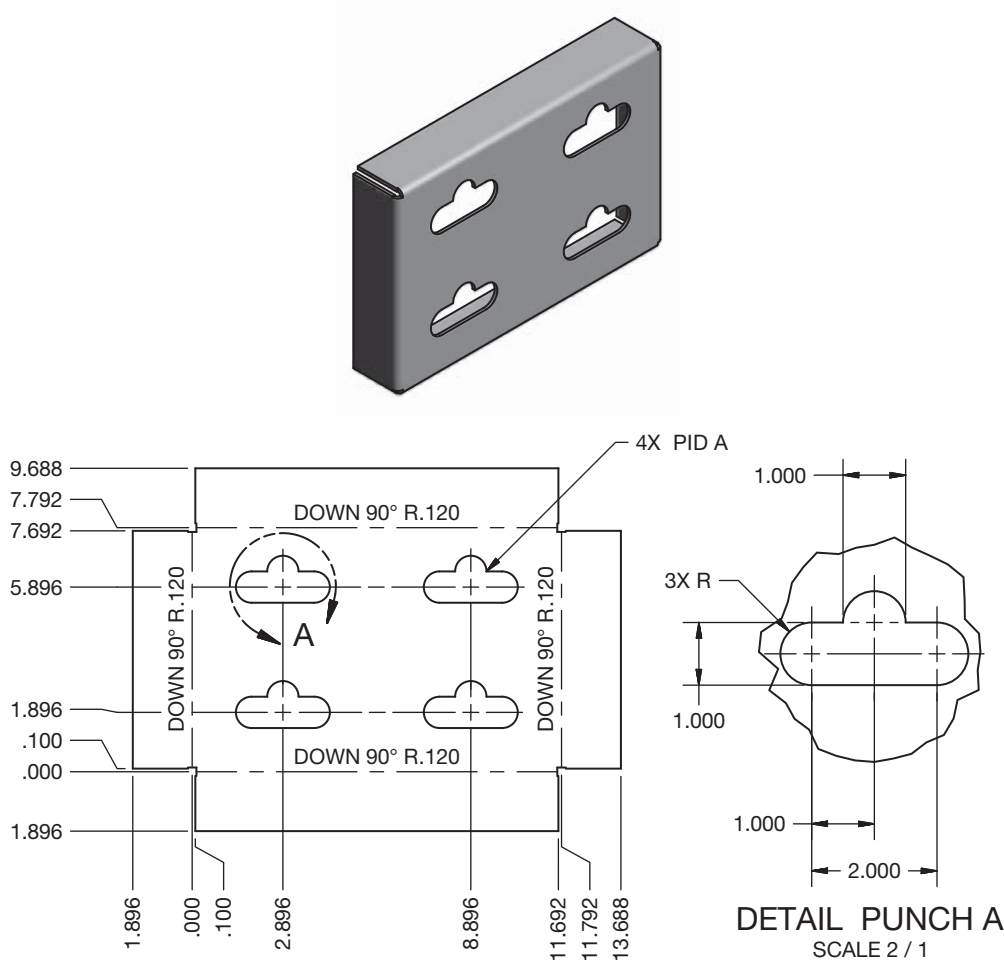
**FIGURE 19.37** (a) A drawing using registration marks. (b) The different registration mark symbols that can be used.

## SHEET METAL PUNCH APPLICATIONS

A **sheet metal punch** is a press or similar tool used to form a hole or specific shape in sheet metal. Most punch presses are large machines with a hydraulic ram at the top and a table or bed with brushes or rollers that allow the sheet metal workpiece to traverse smoothly. Punch presses are usually operated by computer numerical control (CNC), so they can run automatically according to a program used to perform the desired punching operations at locations designated on the drawing. Punch presses are usually referred to by their tonnage. A 20-ton press is commonly used in industry, but presses are available up to 2500 ton. A die set is used to cut the required feature during the punch press operation. A die set has a punch and die that cut out the desired feature in the sheet metal when pressed together. The punch is attached to the ram during the punching process. The ram moves up and down in a vertical motion, forcing the punch through the material into the die. Punch tools can also partially penetrate the face of the sheet metal, providing an embossed indentation or a cut and indentation in a single operation.

Features cut, machined, or punched into sheet metal parts are described throughout this chapter using unidirectional dimensioning, rectangular coordinate dimensioning without

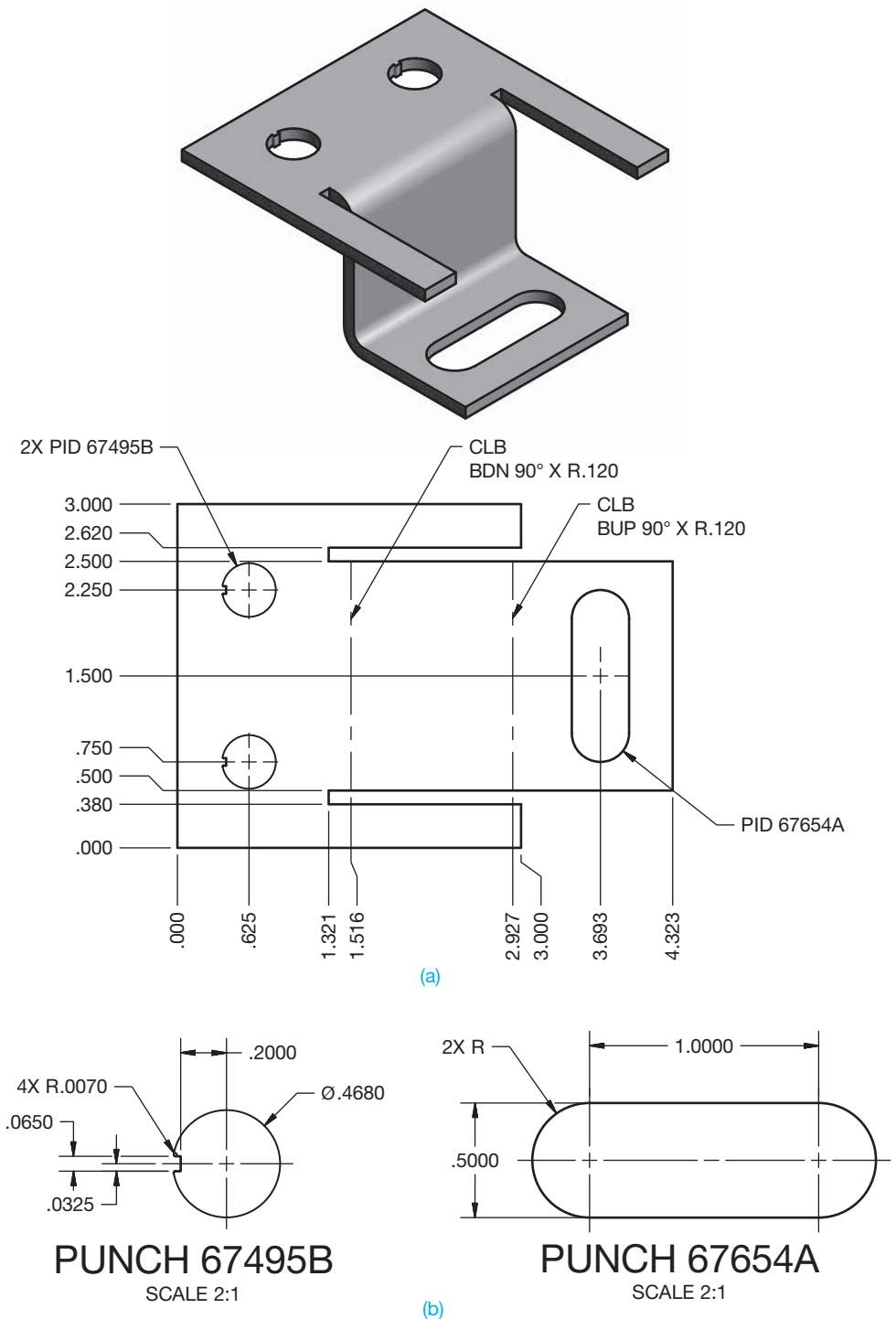
dimension lines, and tabular dimensioning. Companies that do precision sheet metal design, drafting, and fabrication generally have an assortment of punch tools for creating punching operations on parts. The company usually has a unique system of tooling identification referred to as punch identification (ID). This punch ID information is stored with the geometric data that defines the part feature based on the design and drafting requirements for the desired shape. It is important for the center of the punch feature to be dimensioned because the center of the feature controls the location where the punch tool cuts the desired shape. A very simple drafting application can show a single punch operation in a part as in Figure 19.38. The punch ID (PID) is PID A. The punch press automatically punches all four features at the desired locations at the same time. The **DETAIL PUNCH A** in this drawing is used to design the specific die set requirements. The detail can be placed on the drawing or left off, depending on company requirements. The example shown in Figure 19.38 is generally too basic for applications found in most companies. A punch ID is typically a designated value such as a number that matches the number on the die set to be used to punch the feature.



**FIGURE 19.38** A very simple drafting application showing a single punch operation in a part. The punch ID is PUNCH A. The punch press automatically punches all four features at the desired locations at the same time. Dimension values in this figure are in inches.

Figure 19.39 shows two different punch identifications used to cut features in a part. The drawing shown in Figure 19.39a provides PID 67495B and PID 67654A used to punch two different features in the part. The detail drawings of the punch features shown in Figure 19.39b are generally not provided on the part drawing, but it is used to design the die

set. CADD tools are available that allow you to extract the specified punch ID into a specific note or for use in a form of tabular dimensioning. The punch generally cuts through the part unless a depth is specified. A depth is typically appropriate when you are preparing a 2-D drawing to identify the punch depth.



**FIGURE 19.39** Two different punch identifications used to cut features in a part. (a) PID 67495B and PID 67654A used to punch two different features in the part. (b) The detail drawings of the punch features are generally not provided on the part drawing, but it is used to design the die set. Dimension values in this figure are in inches.

# PROFESSIONAL PERSPECTIVE

This chapter covers the type of drafting used in the precision sheet metal fabrication industry. The types of items made in the precision sheet metal industry are electronics chassis, automotive (cars, trucks, and tractors) sheet metal components, and aircraft skin and components. The dimensioning and tolerancing for precision sheet metal parts are critical, and rectangular coordinate dimensioning

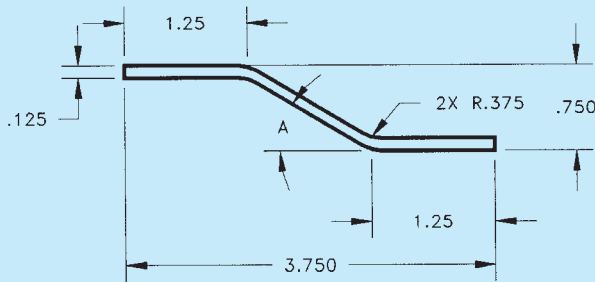
without dimension lines, baseline, and tabular dimensioning is often used with close tolerances to achieve an accurate layout. If you enter the precision sheet metal fabrication industry, you need to have a good understanding of geometric dimensioning and tolerancing (GD&T), material bending and allowance, and precision sheet metal fabrication methods.

MATH APPLICATIONS

## SHEET METAL BEND ANGLES

It is required to find bend angle A for a sheet of metal having the cross section shown in Figure 19.40. The solution to this problem requires working with *two* right triangles because thickness of the material must be taken into account. Figure 19.41 is a drawing of the solution. OML stands for outside mold line. The steps that were taken are the following:

1. Find the angle of the large triangle with inverse tan  $\left(\frac{.75}{1.25}\right) = 31.0^\circ$ .
2. Find the hypotenuse of both triangles with  $\sqrt{1.25^2 + .75^2} = 1.4578$ .

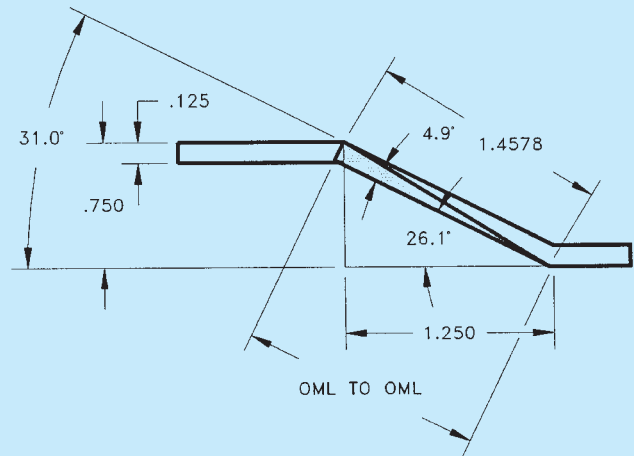


**FIGURE 19.40** Sheet metal with two identical bends. Dimension values in this figure are in inches. © Cengage Learning 2012

3. Find the angle of the slender, shaded triangle with inverse sin  $\left(\frac{.125}{1.4578}\right) = 4.9^\circ$ .
4. Subtract the two angles to find the bend angle.

$$A = 31.0 - 4.9 = 26.1^\circ$$

If the true distance along the bend (OML to OML) is known, then the problem is much simpler and requires working with only one right triangle.



**FIGURE 19.41** Triangles drawn to assist in solving the bend angle problem. © Cengage Learning 2012

## WEB SITE RESEARCH

Use the following Web sites as a resource to help find more information related to engineering drawing and design and the content of this chapter.


Address	Company, Product, or Service
www.adda.org	American Design Drafting Association and American Digital Design Association (ADDA International)
www.amazon.com	Search books for <i>AutoCAD and Its Applications</i>
www.ansi.org	American National Standards Institute (ANSI)

(Continued)

www.asme.org	American Society of Mechanical Engineers (ASME)
www.globalspec.com	The Engineering Web makes it faster and easier for you to research topics, products, and services by limiting your search to technical and engineering-related Web sites.
www.g-w.com	Select “Technical and Trades Technology,” followed by “CAD/Animation/Drafting,” and look for the latest, or your desired, edition of <i>AutoCAD and Its Applications, Basic</i> .
www.engineersedge.com	Find information on design, engineering, and manufacturing processes.
www.fmanet.org	Fabricators & Manufacturers Association, International. Provides educational training programs and journals on metal forming and processing.
www.industrialpress.com	Information about the <i>Machinery’s Handbook</i> . This is a valuable resource for manufacturing standards, sizes, tolerances, fits, materials, and anything else you can think of for design and drafting.
www.industrialpress.com	Online trigonometry tables
www.iso.org	International Organization for Standardization
www.sae.org	Find information and publications related to the Society of Automotive Engineers.
www.smacna.org	Sheet Metal and Air Conditioning Contractors’ National Association. Provide construction manuals, products and services, and help finding expertise contractors.
www.wikipedia.org	Provides general guidelines information on sheet metal and the material and forming processes.

# Chapter 19

## Chapter 19 Precision Sheet Metal Drafting Test

 To access the Chapter 19 test, go to the Student CD, select **Chapter Tests and Problems**, and then **Chapter 19**. Answer the questions

with short, complete statements, sketches, or drawings as needed. Confirm the preferred submittal process with your instructor.

## Chapter 19 Precision Sheet Metal Drafting Problems

### INSTRUCTIONS

1. From the selected sketch, draw the given views.
2. Include all dimensions needed using the specified dimensioning system and correct ASME dimensioning standards.
3. Use an appropriate sheet size, border, and ASME standard sheet blocks.
4. Include the following general notes at the lower-left corner of the sheet .5 in. each way from the corner border lines:

#### NOTES:

1. DIMENSIONING AND TOLERANCING PER ASME Y14.5-2009.
2. REMOVE ALL BURRS AND SHARP EDGES.

Additional general notes may be required, depending on the specifications of each individual assignment. Use the following

for tolerances for unspecified inch values. A tolerance block is recommended as described in Chapter 2.

UNSPECIFIED TOLERANCES	
DECIMALS	IN
X	±.1
XX	±.01
XXX	±.005
ANGULAR	±30'
FINISH	125 μin.

For metric drawings, provide a general note that states TOLERANCES FOR UNSPECIFIED DIMENSIONS COMPLY WITH ISO 2768-m. Provide a general note that states SURFACE FINISH 3.2 μm UNLESS OTHERWISE SPECIFIED.

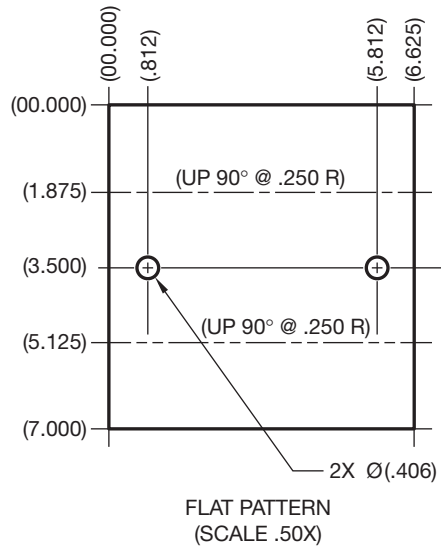
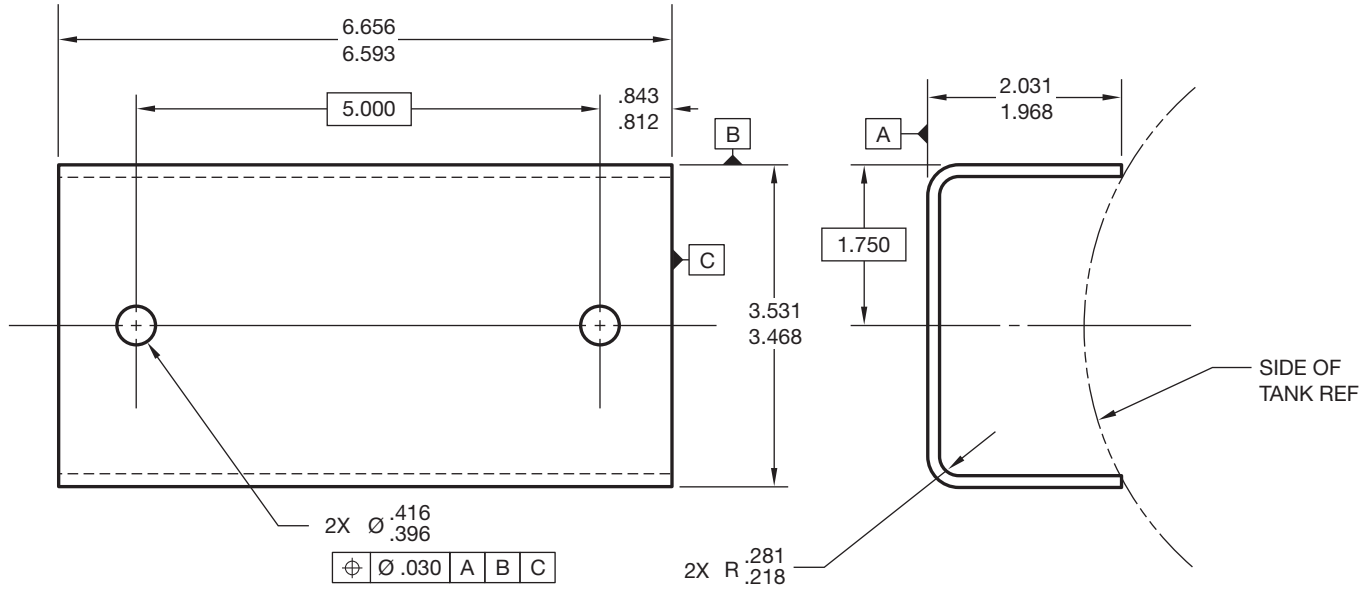
Part 1: Problems 19.1 Through 19.12

PROBLEM 19.1 Drawing displayed in form view and flat pattern (in.)

Part Name: Mounting Bracket

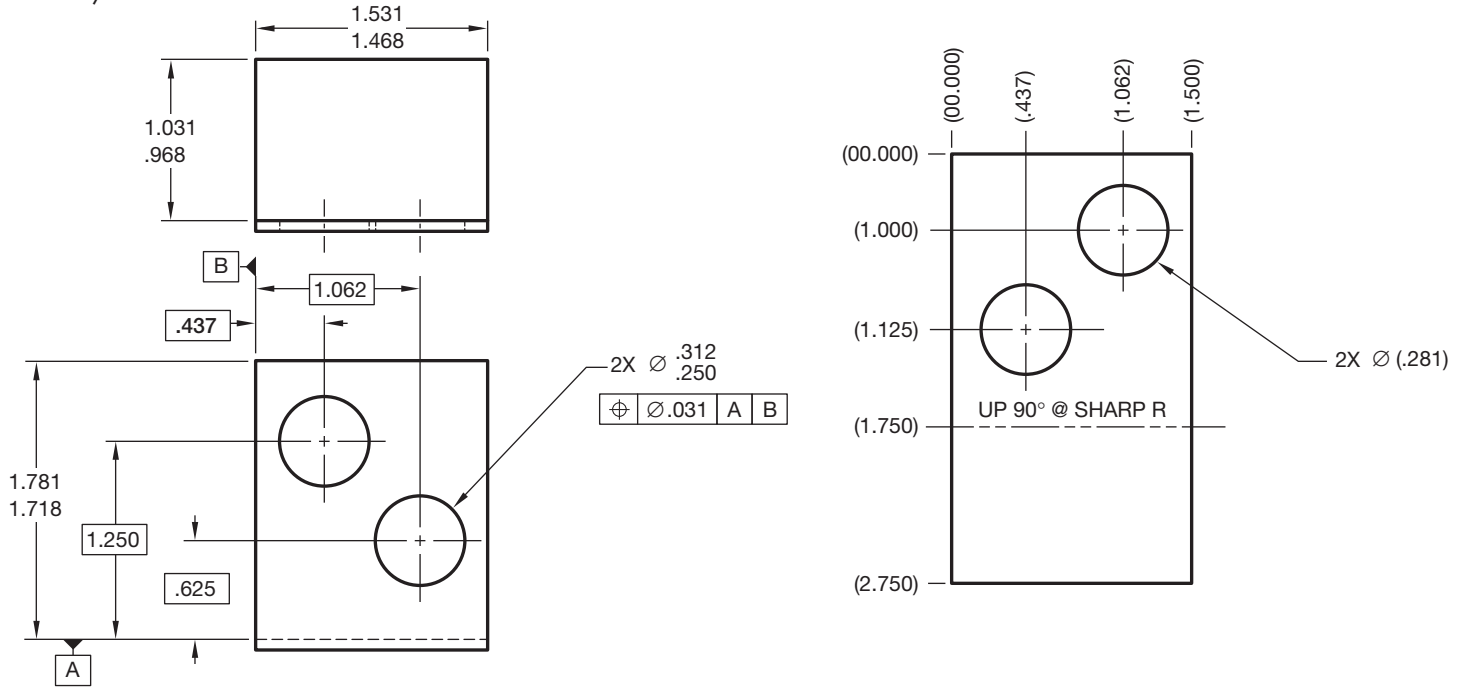
Material: .23 THK 5086-H32

Courtesy TEMCO



**PROBLEM 19.2** Drawing displayed in form view and flat pattern (in.)

Part Name: Bracket  
 Material: 14 GA GALV CRS  
 Courtesy TEMCO

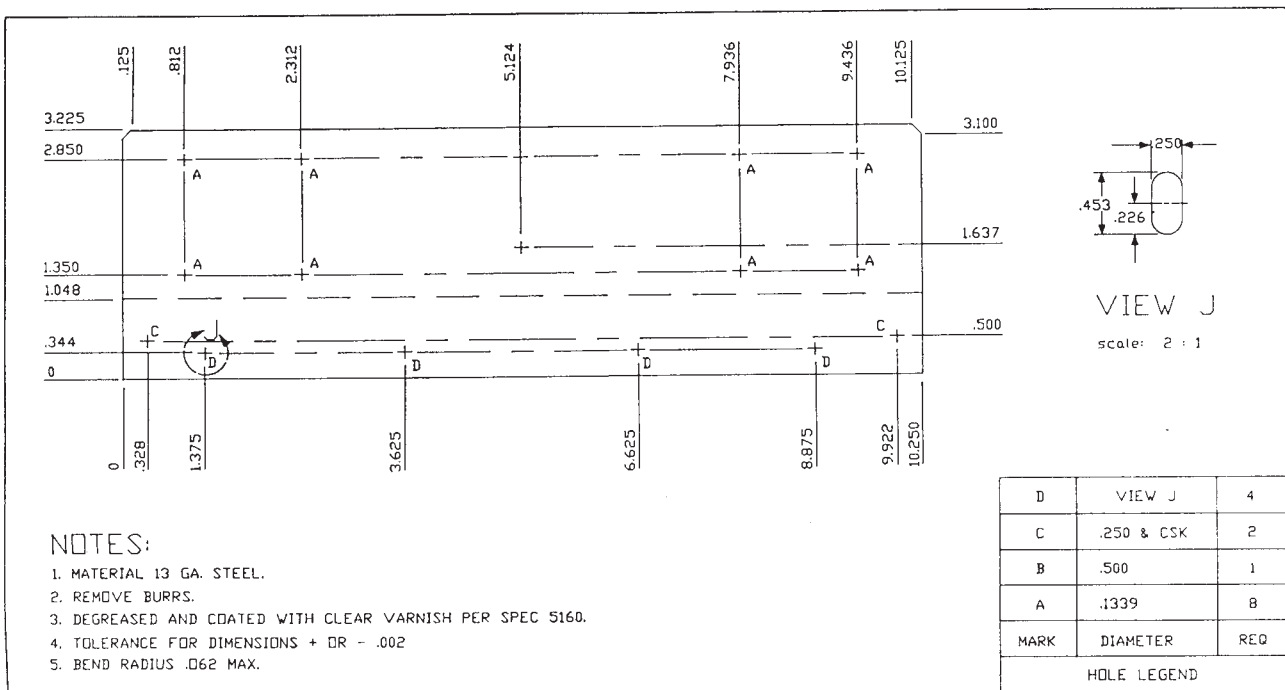


**PROBLEM 19.3** Chassis layout (in.)

Part Name: Chassis  
 Material: Aluminum  
 Given: The engineer's rough sketch of a computer component chassis.

Do the following using correct ASME standards:

1. Make a flat pattern drawing of the given chassis on properly sized sheet. Full scale is recommended.
2. Use arrowless tabular dimensioning from the given datums.



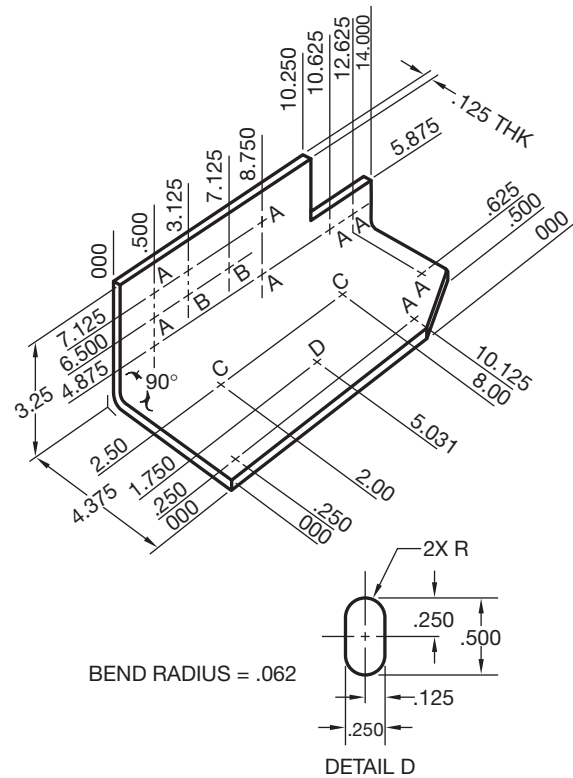


**PROBLEM 19.4 Chassis layout**

Given: The engineer's rough sketch of a computer component chassis.

Do the following:

1. Make a flat pattern drawing of the given chassis on a properly sized sheet. Full scale is recommended. Establish the flat pattern layout dimension by bend allowance calculations. Show all math formulas and calculations on another paper.
2. Use arrowless tabular dimensioning from the given datums.



DIMENSIONING TABLE			
Hole Symbol	Hole Diameter	Depth	Quantity
A	.123	Through	9
B	.230	Through	2
C	.469	.030	2
D	See detail D	Through	1

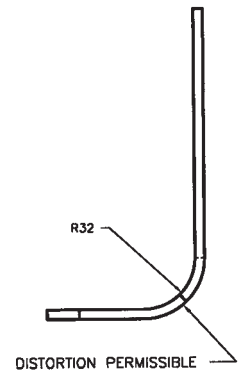
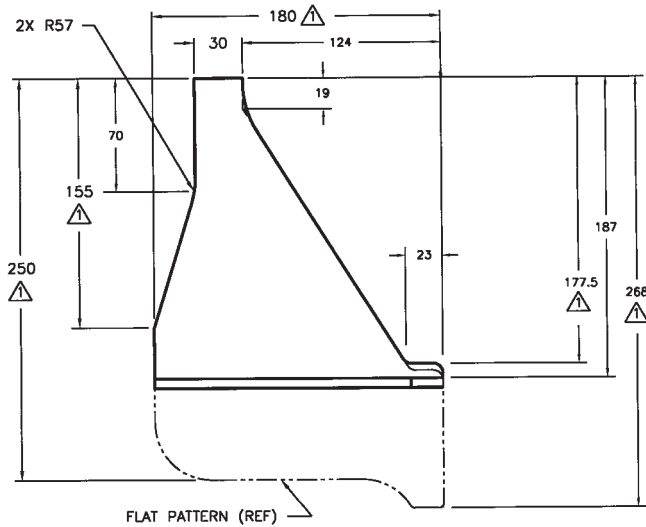
3. Standard dimensioning is needed for the total length of flat pattern and a dimension from one datum to the bend line in the flat pattern.

**PROBLEM 19.5 Display of part in form view with flat pattern shown as phantom line (in.)**

Part Name: Plate-formed

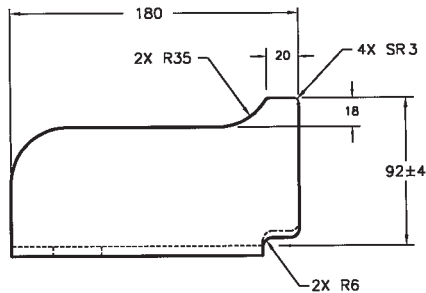
Material: HC-112 6 mm THK

Problem based on original art courtesy Hyster Company.



▲ DIMENSIONS ARE IN FLAT

**METRIC**



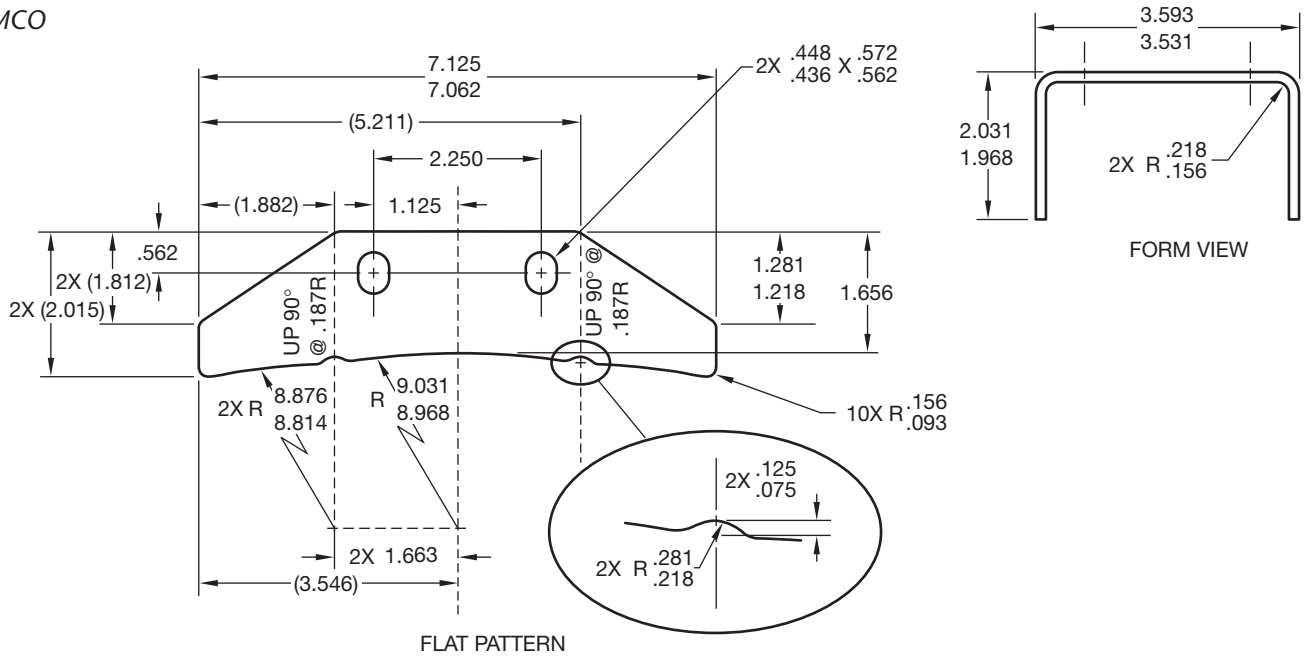
**PROBLEM 19.6** Display of part in form view and in flat pattern (in.)

Part Name: Mounting Bracket

Material: 11 GA A569

Courtesy TEMCO

Given the following engineer's layout, draw the flat pattern and the formed view. Use geometric dimensioning and tolerancing as shown.

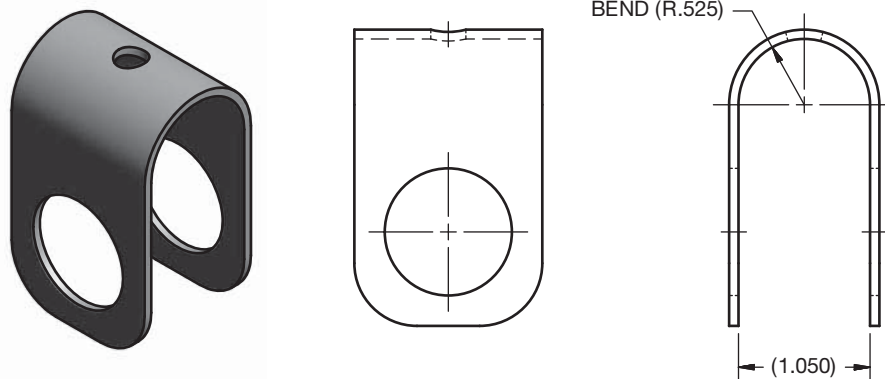
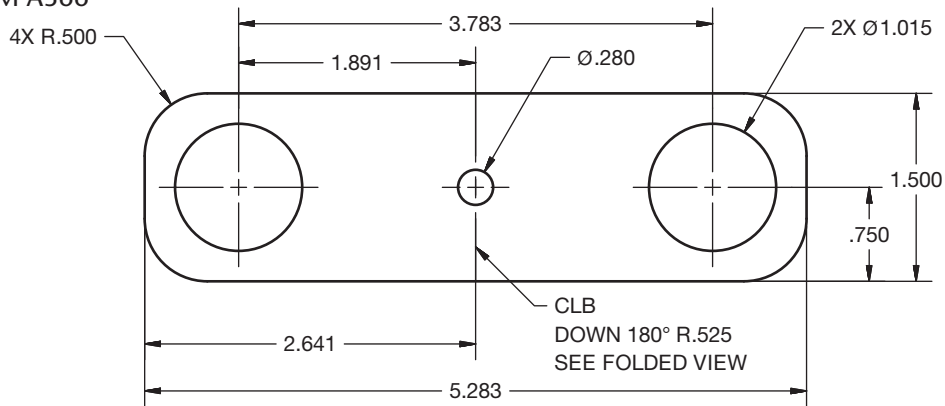


**PROBLEM 19.7** Display of 3-D part model, part in form view and with flat pattern (in.)

Part Name: U-Strap

Material: 14 GA ASTM A366

Draw the 3-D model, formed views, and flat pattern using unidirectional dimensioning.



© Cengage Learning 2012

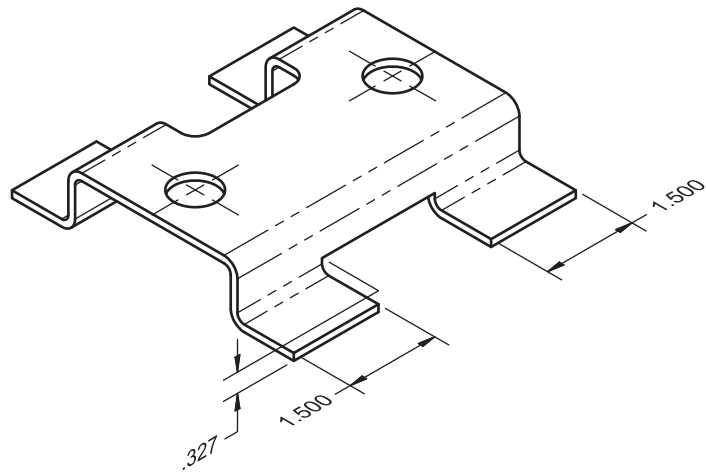
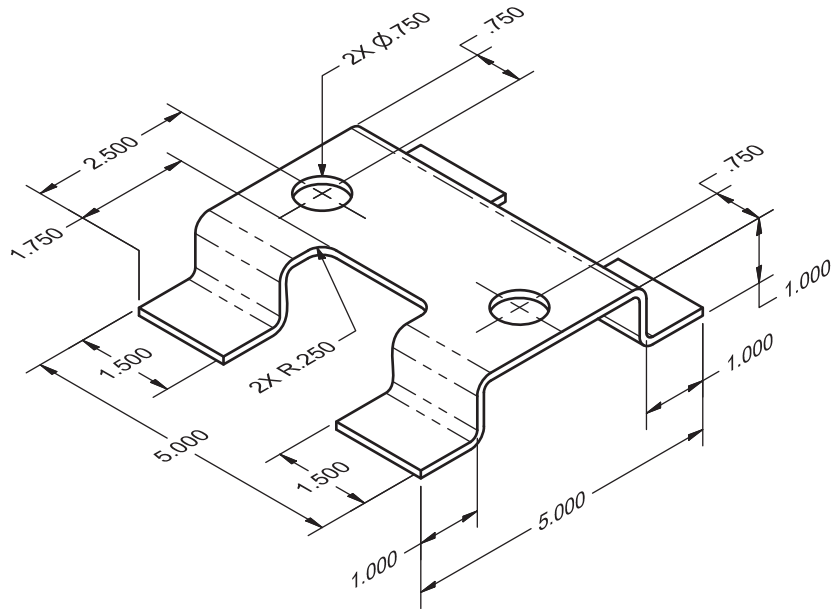
PROBLEM 19.8 Flat pattern (in.)

Part Name: Bracket

Material: 11 gage (.1196 in.) SAE 1040 steel

The bend radius is equal to the thickness of the material.

Draw the flat pattern using unidirectional dimensioning.



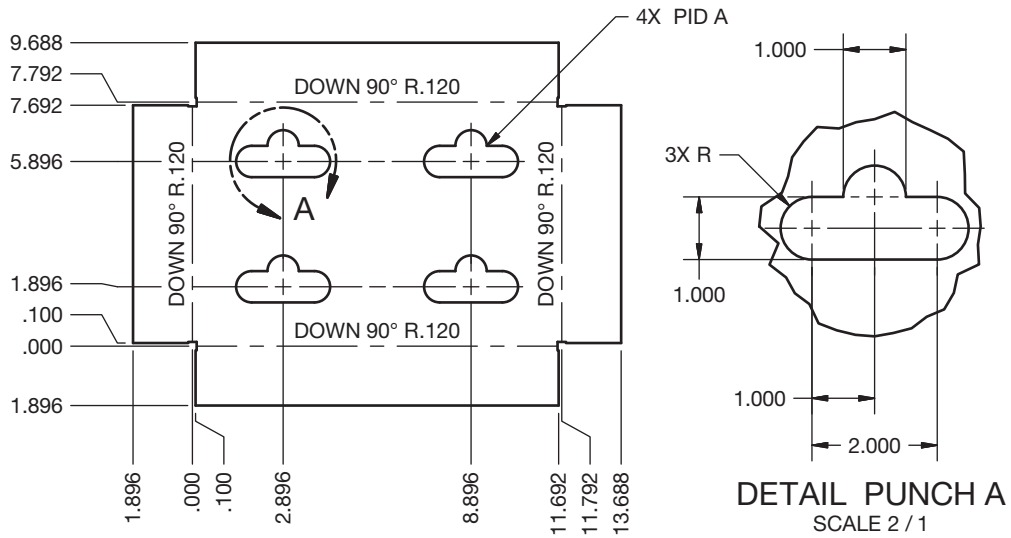
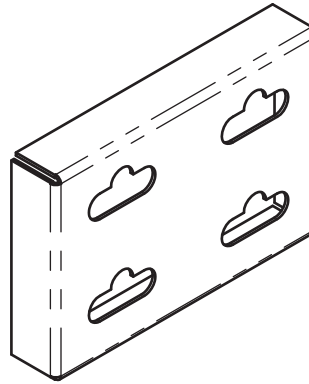
© Cengage Learning 2012

**PROBLEM 19.9 3-D model, flat pattern, and punch ID (in.)**

Part Name: Mounting Stand

Material: 11 gage (.1196 in.) ASTM 525

Draw the 3-D model and the flat pattern using rectangular coordinate dimensioning without dimension lines. Use the punch identification and draw the punch details.



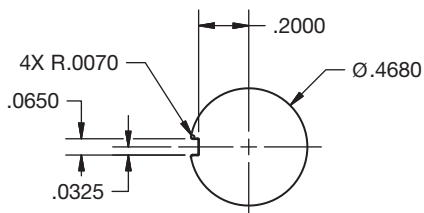
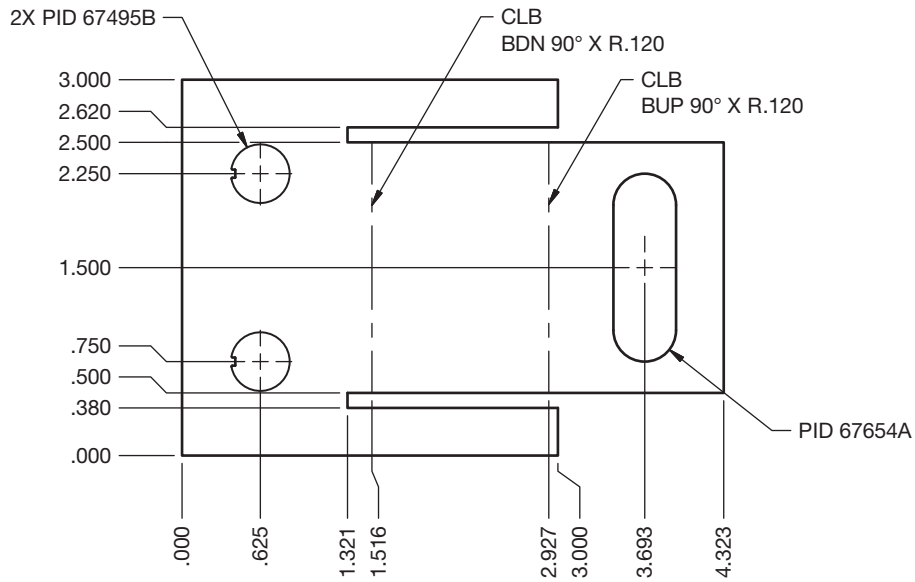
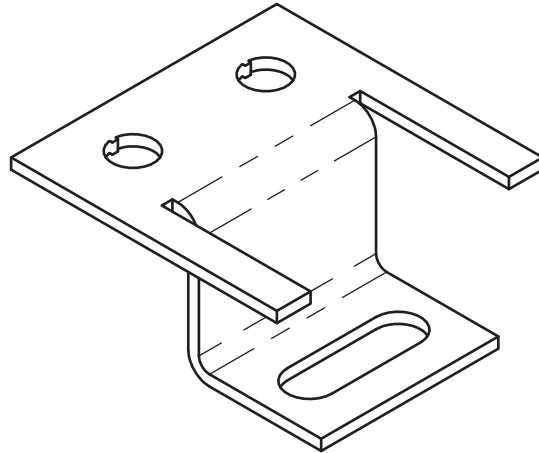
© Cengage Learning 2012

**PROBLEM 19.10 3-D model, flat pattern, and punch ID (in.)**

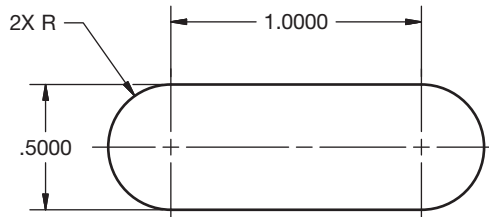
Part Name: Support Bracket

Material: 11 gage (.1196 in.) ASTM 304

Draw the 3-D model and the flat pattern using rectangular coordinate dimensioning without dimension lines. Use the punch identification and draw the punch details.



**PUNCH 67495B**  
SCALE 2:1



**PUNCH 67654A**  
SCALE 2:1

© Cengage Learning 2012

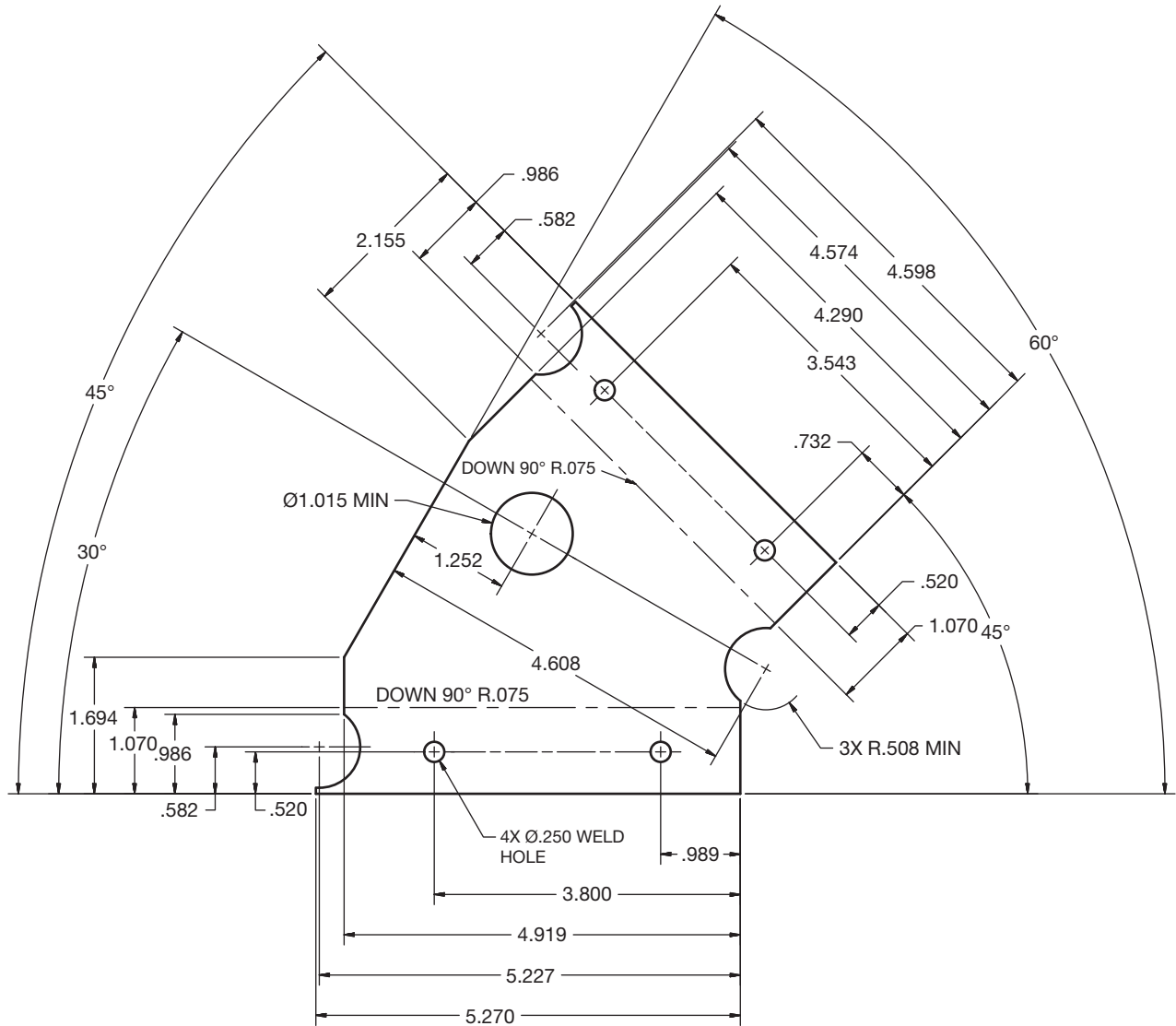
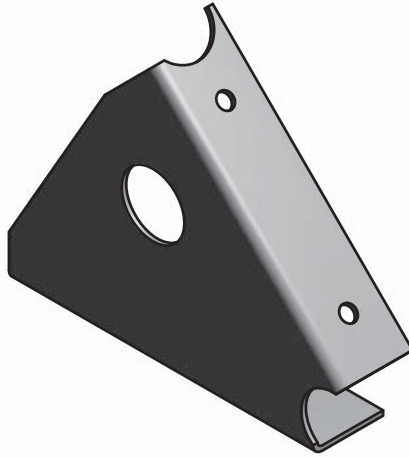
**PROBLEM 19.11 3-D model and flat pattern (in.)**

Part Name: Left Outer Tri-bracket

Material: 18 gage ASTM 366

Draw the 3-D model and the flat pattern using unidirectional dimensioning.

*Courtesy 2-Kool, Inc.*

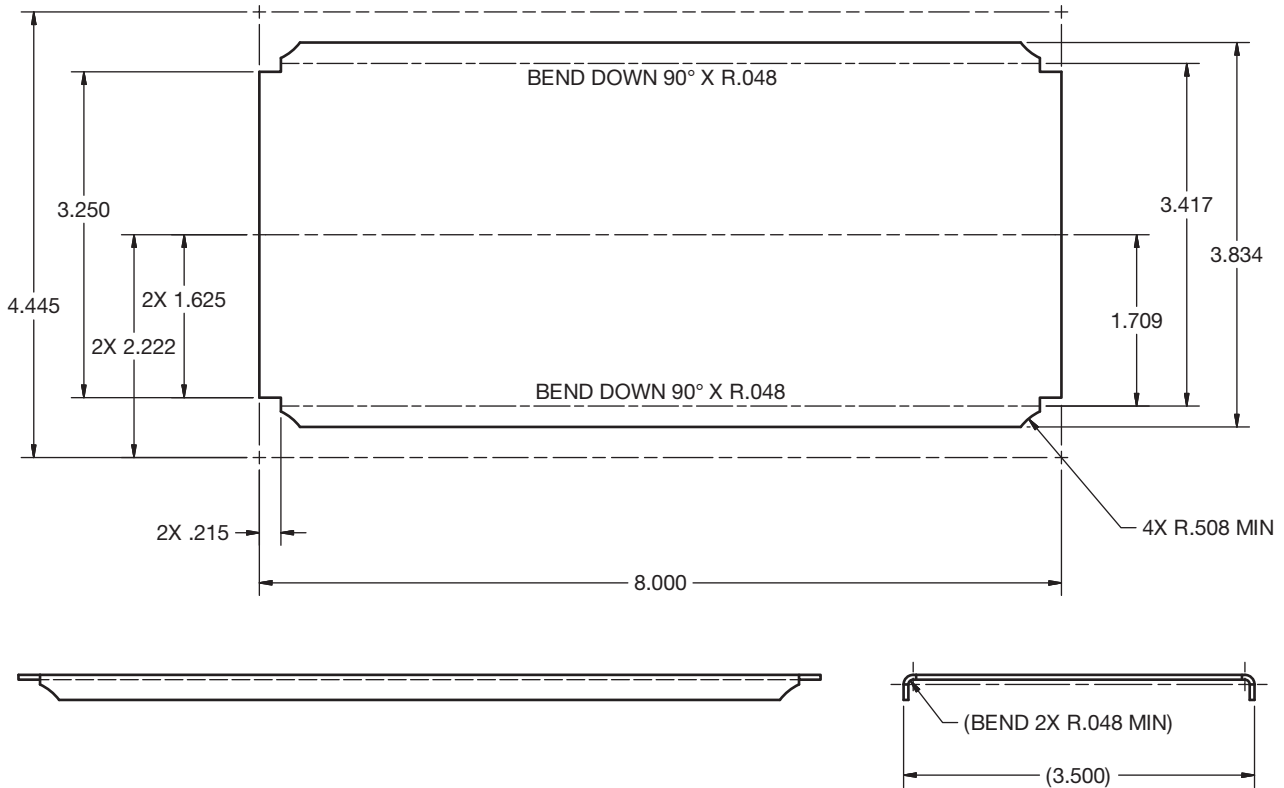


**PROBLEM 19.12 Part in form view and with flat pattern (in.)**

Part Name: Fender Foot Rest  
 Material: 18 gage ASTM 366

Draw the form views and the flat pattern using unidirectional dimensioning.

*Courtesy 2-Kool, Inc.*



**Math Problems**

**Part 2: Problems 19.13 Through 19.18**

To access the Chapter 19 problems, go to the Student CD, select **Chapter Tests and Problems** and **Chapter 19**, and then open the math problem of your choice or as assigned by your instructor. Solve the problems using the instructions provided on the CD, unless otherwise specified by your instructor.

# CHAPTER 20

## Electrical and Electronic Drafting

### LEARNING OBJECTIVES

After completing this chapter, you will:

- Draw block, elementary, highway, wireless, and cable electrical diagrams.
- Draw a cable assembly.
- Draw a set of electrical power system substation plans, including plot plan, bus plan and elevation, grounding layout and details, conduit installation details, electrical equipment layout, power panel detail, electrical floor plan, lighting plan, and security lighting plan.
- Draw an industrial electrical schematic.
- Prepare electrical drawings from engineering sketches.
- Draw electronic block and schematic diagrams.
- Create logic diagrams.
- Prepare a printed circuit-board layout.
- Complete a marking and drilling drawing.
- Prepare electronics pictorial drawings.
- Make electronics drawings from given engineering sketches.

## THE ENGINEERING DESIGN APPLICATION

In both electronic and electrical drafting, much of your work involves the use of symbols to show the components of **schematic diagrams**. Schematic diagrams are drawn as a series of lines and symbols that represent the electrical current path and the components of the circuit, and they provide the basic circuit connection information for electronic products. The proper computer-aided design and drafting (CADD) software can greatly simplify drawing electronic and electrical schematic diagrams. CADD offers several advantages,

including the ability to reuse symbols easily. In addition, you can create CADD symbols that automatically prompt for and place the required text in a drawing to define the symbol.

In this example, an electronics engineer provides you with a rough sketch of a circuit diagram (see Figure 20.1). You create the finished drawing with a minimum of time and effort using your CADD symbol library and adding the required text (see Figure 20.2).

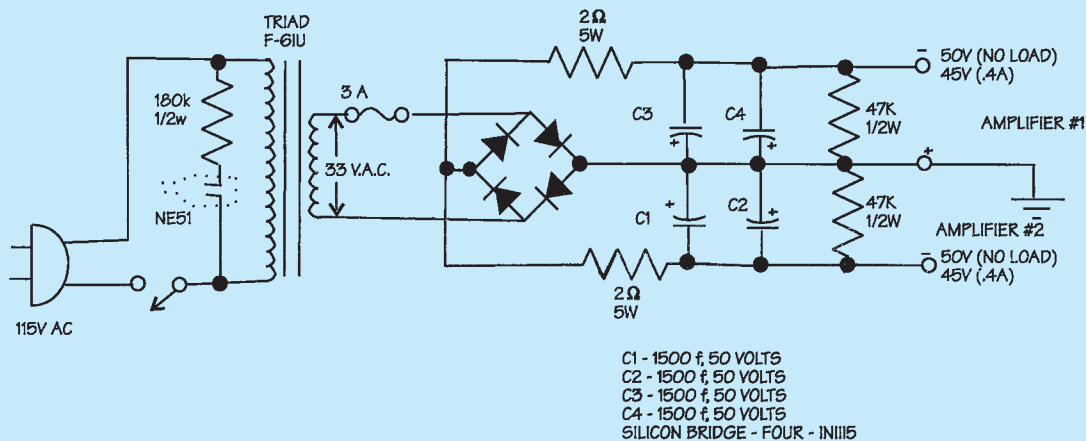


FIGURE 20.1 Engineer's rough computer sketch of a circuit diagram.

© Cengage Learning 2012



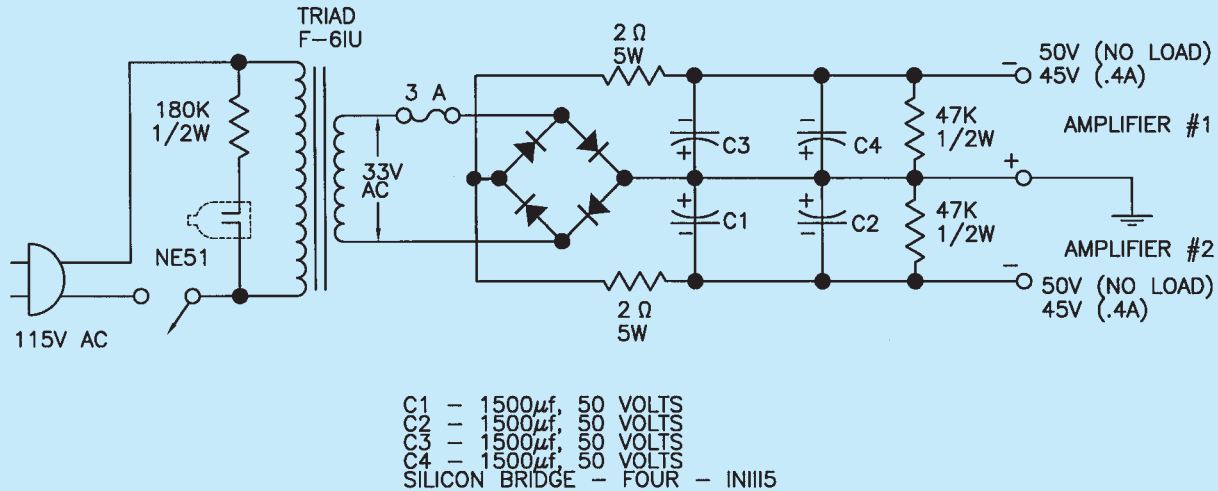


FIGURE 20.2 The finished drawing from the engineer's sketch.

In the fully automated electronics industry, design begins with an engineer's sketch, which goes to an electronics technician who inputs the design into a computer. The computer system automatically evaluates the design and produces a prototype fabrication. The engineer then evaluates the system and makes modifications. After modifications are made and the system is completely tested and approved, the computer layout is sent to the drafter for engineering documentation. The drafter uses the CADD system to check design and drafting standards, evaluate engineering information for documentation accuracy, and correct component values. The drafter adds device

tables that relate exactly how each component attaches to the **printed circuit board (PCB)**. The PCB is a flat plate or base of insulating material containing a pattern of conducting material and becomes an electrical circuit when components are attached. The entire process is computerized. The drawing then progresses through the system to the automatic generation of the circuit boards. The drafter works closely with the circuit-board computer program to ensure the accuracy of the product. This system varies from one industry to the next, but, as you can see, the electronics drafter is an important link between the engineering department and the final product.

© Cengage Learning 2012

## INTRODUCTION TO ELECTRICAL AND ELECTRONIC DRAFTING

**Electrical drafting** deals with concepts and symbols that relate to high-voltage applications from the production of electricity in power plants through distribution to industry and homes. Although there is often a fine line between electrical and electronic drafting, **electronic drafting** is more oriented toward the design of electronic circuitry for radios, computers, and other low-voltage equipment. Different symbols can be used, depending on the discipline. For example, lighting and power symbols used as part of architectural drawings are different from symbols for devices used in electronics.

prepared in accordance with appropriate electrical and electronic drawing standards. There are several national and international standards for graphic symbols used in circuit diagrams and other electrical and electronic design applications.

**IEC** The International Electrotechnical Commission (IEC) document IEC 60617, *Graphical Symbols for Diagrams*, contains graphic symbols for use in electrotechnical diagrams. The IEC has currently incorporated approximately 1750 symbols into a database. The database covers several areas such as conductors and connecting devices, semiconductors and electron tubes, telecommunications transmission, switching, and peripheral equipment. For more information or to subscribe to the online IEC 60617-DB database, go to the IEC Web site at [www.iec.ch](http://www.iec.ch).

**IEEE** The Institute of Electrical and Electronics Engineers (IEEE) publishes standards related to electronics and electrical engineering and drafting, including standards IEEE 315 and IEEE 315a, *Graphic Symbols*

### STANDARDS

The key to effective communication on electrical and electronic drawings is the use of standardized symbols so that anyone who uses the diagram makes the same interpretation. To ensure proper standardization, engineering drawings and related documents should be

for *Electrical and Electronic Diagrams*, previously published by the ANSI as ANSI Y32.2. For more information or to order standards, go to the IEEE Web site at [www.ieee.org](http://www.ieee.org).

ASME The ASME document ASME Y32.18, *Symbols for Mechanical And Acoustical Elements As Used In Schematic diagrams*, presents symbols and definitions used in constructing schematic diagrams for mechanical and acoustical systems. ASME Y14.34, *Associated Lists*, identifies standards for preparing wire lists. ASME Y14.44, *Reference Designations for Electrical and Electronic Parts and Equipment*, establishes standards for creating and applying reference designations for electrical and electronic parts and equipment. The border and title block used on electrical and electronic drawings can conform to ASME Y14.1, *Decimal Inch Drawing Sheet Size and Format*, or ASME Y14.1M, *Metric Drawing Sheet Size and Format*, standards or they can follow an architectural style, depending on the application and company preference.

This chapter divides the content into the two areas of electrical drafting and electronic schematic drafting. You can focus your interest on electrical drafting for power transmission or electronic drafting for low-voltage applications, or you can study both fields for a broad range of knowledge and skills.

## FUNDAMENTALS OF ELECTRICAL DIAGRAMS

The purpose of electrical diagrams is to communicate information about the electrical system or **circuit** in a simple, easy-to-understand format of lines and symbols. **Electrical circuits** provide the path for electrical flow from the source of electricity, through system components and connections, and back to the source. Electrical diagrams are generally not drawn to scale. The responsibility of the drafter is to organize the information in a logical, orderly manner without crowding and without large variations in spacing layout.

### Pictorial Diagram

**Pictorial diagrams** represent the electrical circuit as a three-dimensional drawing. This type of diagram provides the most realistic and easy-to-understand representation and can commonly be used in sales brochures, catalogs, service manuals, and assembly drawings. Figure 20.3 shows the pictorial drawing of a simple doorbell circuit.

### Schematic Diagram

Schematic diagrams are drawn as a series of lines and symbols representing the electrical current path and the components of the circuit. Figure 20.4 shows a schematic diagram of the doorbell circuit.

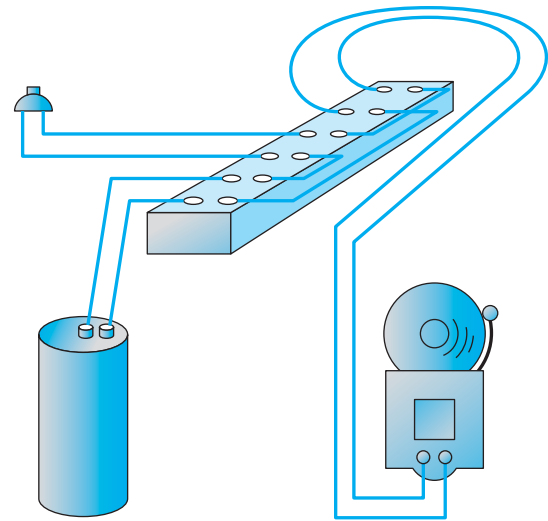


FIGURE 20.3 Pictorial drawing of a simple doorbell circuit.

© Cengage Learning 2012

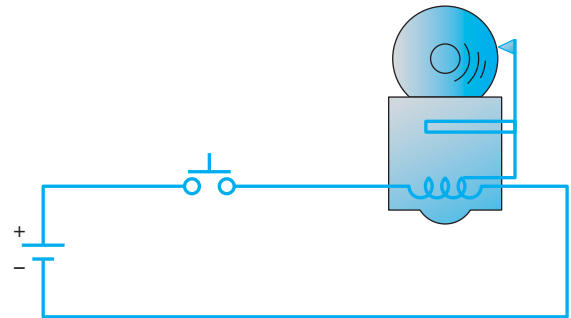


FIGURE 20.4 Schematic diagram of doorbell circuit shown in Figure 20.3.

© Cengage Learning 2012

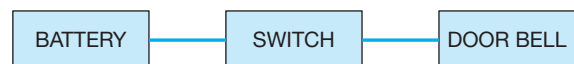


FIGURE 20.5 Block diagram of the doorbell circuit shown in Figure 20.3.  
© Cengage Learning 2012

### Block Diagram

The **block diagram** is a simplified version of the schematic diagram. Simplified symbols exhibit a minimum of detail of the component and generally no connections at individual terminals as shown in Figure 20.5.

### Wiring Diagram

The **wiring diagram** is a type of schematic that shows all of the interconnections of the system components. Wiring diagrams are often referred to as **point-to-point interconnecting wiring diagrams**. A wiring diagram is more detailed than a standard schematic diagram because it shows the layout of individual wire runs. Figure 20.6 shows a wiring diagram of the doorbell circuit.

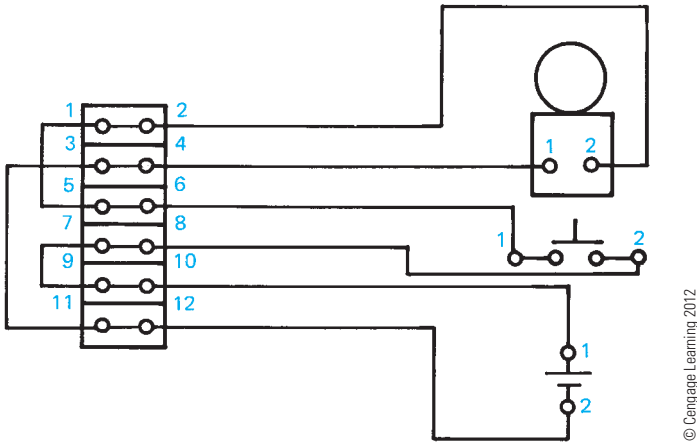


FIGURE 20.6 Wiring diagram of the doorbell circuit shown in Figure 20.3.

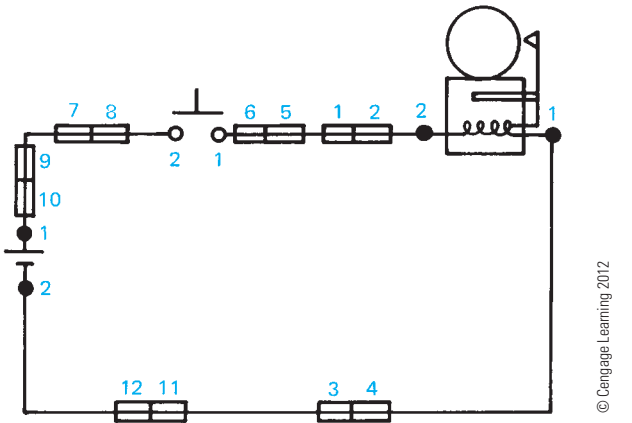


FIGURE 20.7 Schematic wiring diagram of the doorbell circuit shown in Figure 20.3.

### Schematic Wiring Diagram

A **schematic wiring diagram** combines the simplicity of a schematic diagram and the completeness of a wiring diagram. The complete circuit is drawn as a series of lines and symbols that represent the electrical current path and the components of the circuit. Connection terminals are shown in their proper locations along the circuit (see Figure 20.7).

### Highway Wiring Diagram

Highway wiring diagrams, also known as **highway diagrams**, are used for fabrication, quality control, and troubleshooting of the wiring of electrical circuits and systems. A highway wiring diagram is a simplified or condensed representation of a point-to-point interconnecting wiring diagram. Highway wiring diagrams can be used when it becomes difficult to draw individual connection lines because of diagram complexity or when it is not necessary to show all of the wires between terminal blocks.

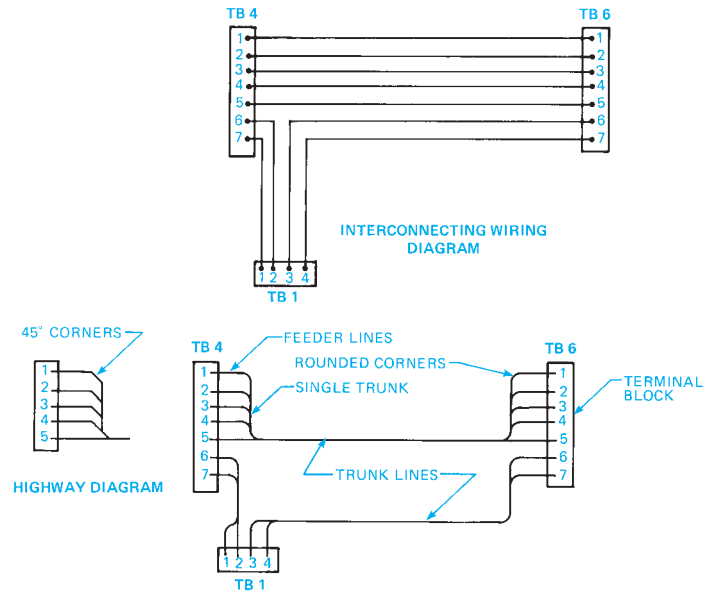


FIGURE 20.8 An interconnecting wiring diagram and the same electrical system converted to a highway diagram.

The wiring lines are merged at convenient locations into main **trunk lines**, called **highways**, that run horizontally or vertically between component symbols. The lines that run from the component to the trunk lines are called **feed lines**. A code letter, number, or a letter and number identify the feed lines at the point where each line leaves the component. By reducing the number of lines drawn, the wiring diagram becomes easier to draw and interpret. Figure 20.8 shows an interconnecting wiring diagram and the same electricity system converted to a highway diagram.

A complete highway diagram has an identification system that guides the reader through the system, with a code at one terminal to the same corresponding terminal on another component. The IEEE 315 standard, *Graphic Symbols for Electrical and Electronic Diagrams*, includes an identification system made up of the wire destination, terminal number at the destination, wire size, and wire-covering color. Look at Figure 20.9 as you interpret the following code:

Component—M3	Component—TB6
TB6/1-B2	M3/3-B2
TB6 = Destination	M3 = Destination
1 = Terminal at Destination	3 = Terminal at Destination
B = Wire Size	B = Wire Size
2 = Color of Wire Covering	2 = Color of Wire Covering

### Wireless Diagram

**Wireless diagrams** are similar to highway diagrams except that interconnecting lines are omitted as shown in Figure 20.10.

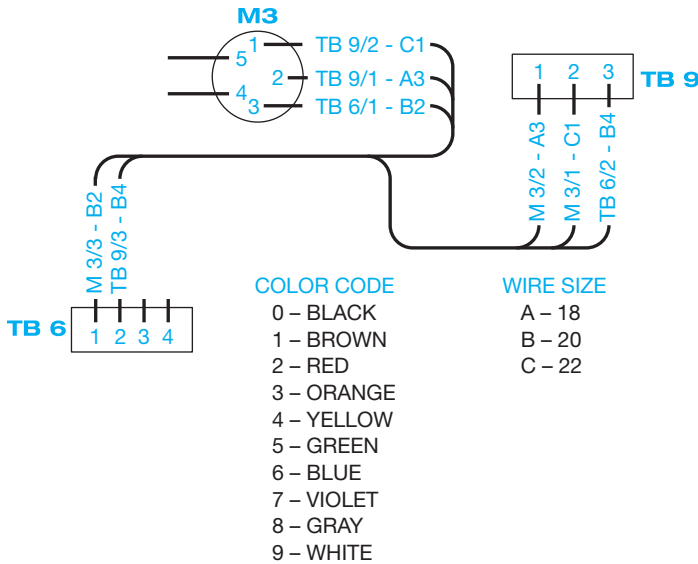


FIGURE 20.9 Highway wiring diagram. © Cengage Learning 2012

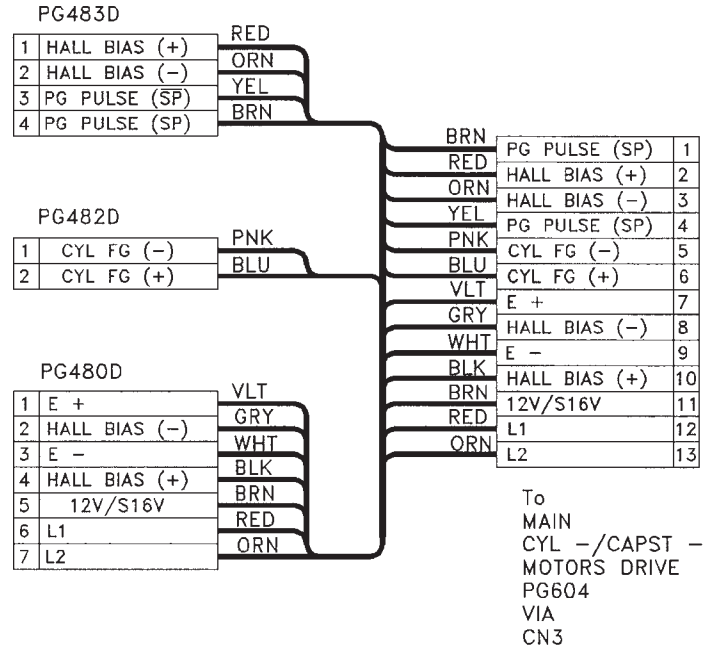


FIGURE 20.11 Cable diagram. Courtesy RCA Consumer Electronics

### Cable Diagram and Assemblies

Cable diagrams are associated with multiconductor systems. A multiconductor is a cable or group of insulated wires put together in one sealed assembly. For example, the trunk line shown in the highway diagram in Figure 20.8 or 20.9 can be a multiconductor. Cable systems are made up of insulated conductor wires, protective outer jacket or some other means of holding the wires together, and connectors at one end or both ends. Cables are used to connect components, equipment assemblies,

and systems together. Cable diagrams usually provide circuit destination, conductor size, number of leads, conductor type, and power rating. Figure 20.11 shows a cable diagram.

Cable assemblies, also known as cable harness diagrams, are drawn to scale with dimensions and include a parts list that is coordinated with the drawing by identification balloons. Figure 20.12 shows a cable assembly.

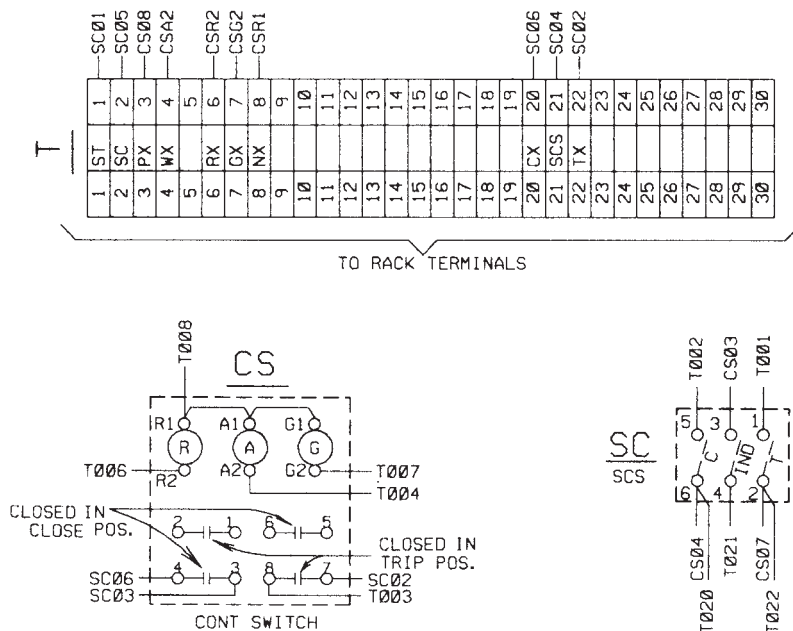


FIGURE 20.10 Wireless diagram.

Courtesy Bonneville Power Administration

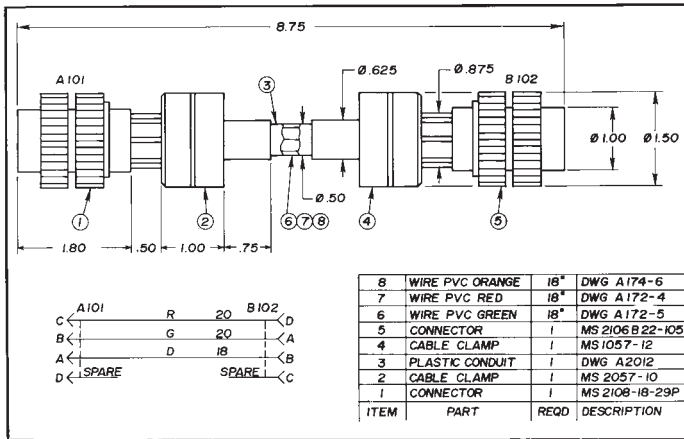


FIGURE 20.12 Cable assembly. © Cengage Learning 2012

## GENERATION, TRANSMISSION, AND DISTRIBUTION OF ELECTRICITY

Electricity is generated around the world in hydroelectric, coal burning, nuclear, wind generation, and solar power plants. The electricity created at the generating station is increased in voltage at a step-up transformer and sent through high-voltage lines to a switching station where the electricity is retransmitted to various locations. Before electricity is usable, it goes to a substation where a step-down transformer converts the high voltage to a lower voltage for heavy industry, or transmission through lines to a distribution substation for further voltage reduction and distribution to light commercial and residential users.

## ELECTRIC POWER SUBSTATION DESIGN DRAWINGS

A **substation** is the part of the electrical transmission system where electricity is switched or transformed from a very high voltage to a conveniently usable form for distribution to homes or businesses. Substation design drawings are an important part of any power-supply system.

### One-Line Diagrams

The **one-line diagram** is a simple way for electrical engineers and drafters to communicate the design of an electrical power substation as shown in Figure 20.13.

### Elementary Diagrams

**Elementary diagrams** provide the detail necessary for engineering analysis and operation of the substation equipment by operators or maintenance people. Elementary diagram DC (direct current) circuits show the DC circuits that operate the relaying and controls for the substation equipment. Elementary diagram

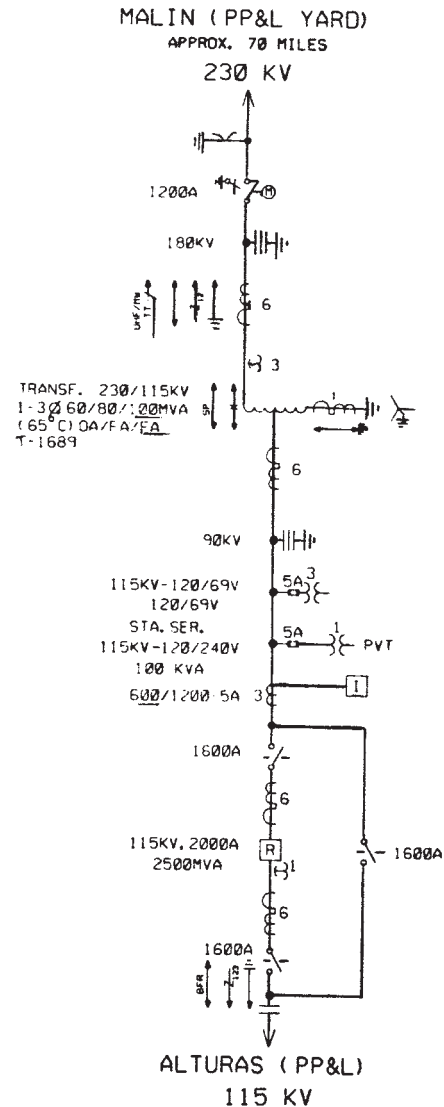


FIGURE 20.13 A one-line diagram.

AC (alternating current) circuits depict the circuits that provide information for both the protective relays and the instruments and meters used by people who work in the substation.

### Schematic Diagrams

The schematic diagram is used to show the relationship of the components and equipment located in the substation. The schematic diagram is more detailed than the one-line diagram.

### STANDARDS

**IEEE** Most standards for the preparation of electrical diagrams use symbols in accordance with IEEE 315, *Graphic Symbols for Electrical and Electronic Diagrams*. Show any special variation to symbols in a legend or with a description in a general note. Figure 20.14 shows common electrical equipment symbols.

SYMBOL	DESCRIPTION	SYMBOL	DESCRIPTION	SYMBOL	DESCRIPTION
	REMOVABLE LINK		LOAD-BREAK DISCONNECT SWITCH - (NO FAULT INTERRUPTING RATING) GANG OPERATED (LEVER OR GEARBOX)		REGULATOR BYPASS SWITCH (WITH STEP VOLTAGE REGULATOR)
	DISCONNECT LINK- HOT-STICK OPERATED		LOAD-BREAK DISCONNECT SWITCH - (NO FAULT INTERRUPTING RATING) GANG OPERATED (MOTOR)		COUPLING CAPACITOR POTENTIAL DEVICE
	FUSE		LOAD-BREAK DISCONNECT SWITCH - (WITH FAULT INTERRUPTING RATING) GANG OPERATED (MOTOR)		FAULT LOCATOR COUPLING
	FUSE, DISCONNECTING TYPE—HOOK OPERATED		GROUND SWITCH -GANG OPERATED (LEVER OR GEARBOX)		SCHEMATIC SYMBOLS
	DISCONNECT SWITCH - HOOK OPERATED		GROUND SWITCH -GANG OPERATED (MOTOR)		INITIATING - REMOTE UNIT (LOCAL SUBSTATION)
	DISCONNECT SWITCH - GANG OPERATED (LEVER OR GEARBOX)		GROUND SWITCH -GANG OPERATED AUTOMATIC CLOSING		RECEIVING - MASTER UNIT (CONTROL CENTER)
	DISCONNECT SWITCH WITH SURGE SUPPRESSION RESISTORS - GANG OPERATED (LEVER OR GEARBOX)		OIL SWITCH (NO FAULT INTERRUPTING RATING)		ANALOG TYPE (INITIATING)
	QUICK-BREAK DISCONNECT SWITCH-GANG OPERATED (LEVER OR GEARBOX)		POWER CIRCUIT BREAKER		DIGITAL TYPE (INITIATING)
	DISCONNECT SWITCH - GANG OPERATED (MOTOR)		POWER CIRCUIT BREAKER WITH AUTOMATIC RECLOSING		PULSE-PRINT TYPE (INITIATING)
	DISCONNECT SWITCH - GANG OPERATED AUTOMATIC OPENING		POWER CIRCUIT BREAKER-DRAWOUT CONSTRUCTION		

TELEMETERING SYMBOLS

SCHEMATIC SYMBOLS

SCHEMATIC SYMBOLS

FIGURE 20.14 Electric power systems schematic symbols.

RELAY SYMBOL	RELAY DESCRIPTION	RELAY SYMBOL	RELAY DESCRIPTION	RELAY SYMBOL	RELAY DESCRIPTION
	OVER, NONDIRECTIONAL		PHASE OVERCURRENT		PILOT WIRE RELAYS
	UNDER, NONDIRECTIONAL		GROUND OVERCURRENT		PILOT WIRE TRANSFER TRIP (INITIATING)
	RECEIVING, UNDER, DIRECTIONAL		PHASE OVERCURRENT (INSTANTANEOUS)		PILOT WIRE TRANSFER TRIP (RECEIVING)
	OVER, DIRECTIONAL, INITIATING (ARROWS)		GROUND OVERCURRENT (INSTANTANEOUS)		CARRIER CURRENT DIRECTIONAL COMPARISON
	INDICATE TRIPPING DIRECTION)		ZERO-SEQUENCE OR POLARIZING OVERCURRENT		CARRIER CURRENT PHASE COMPARISON
	RELAY WITH TRIP ATTACHMENT		NEGATIVE SEQUENCE OVERCURRENT		CARRIER CURRENT TRANSFER TRIP (INITIATING)
	GROUND		POWER		CARRIER CURRENT TRANSFER TRIP (RECEIVING)
	TEMPERATURE		DISTANCE PHASE - ZONE 1 ONLY		CARRIER CURRENT TRANSFER TRIP (INITIATING AND RECEIVING)
	DIFFERENTIAL		DISTANCE PHASE - ZONES 1 AND 2		CARRIER CURRENT TRANSFER TRIP (INITIATING)
	DISTANCE		DISTANCE PHASE - ZONES 1, 2, AND 3		MICROWAVE PHASE COMPARISON
	CURRENT (ASSUMED IF LETTER C OMITTED)		DISTANCE PHASE - ZONE 2 ONLY		MICROWAVE TRANSFER TRIP (INITIATING)
	VOLTAGE		DISTANCE PHASE - ZONE 3 ONLY		MICROWAVE TRANSFER TRIP (RECEIVING)
	POWER		DISTANCE GROUND - (ZONES INDICATED AS ABOVE)		MICROWAVE TRANSFER TRIP (INITIATING AND RECEIVING)
	FREQUENCY		OUT-OF-STEP BLOCKING		VHF RADIO TRANSFER TRIP (INITIATING)
	BALANCE		OUT-OF-STEP TRIPPING		VHF RADIO TRANSFER TRIP (RECEIVING)
	COMMUNICATION CHANNEL (BASIC)		DIRECTIONAL SYMBOLS		VHF RADIO TRANSFER TRIP (INITIATING AND RECEIVING)
	PILOT WIRE		<b>APPLICATIONS - DIFFERENTIAL RELAYS</b>		UHF RADIO TRANSFER TRIP (INITIATING)
	POWER LINE CARRIER CURRENT		CURRENT DIFFERENTIAL (BASIC)		UHF RADIO TRANSFER TRIP (RECEIVING)
	MICROWAVE		VOLTAGE DIFFERENTIAL		UHF RADIO TRANSFER TRIP (INITIATING AND RECEIVING)
	RADIO		<b>APPLICATIONS - MISCELLANEOUS RELAYS</b>		MICROWAVE GENERATOR DROPPING
	RADIO		SUDDEN PRESSURE		MICROWAVE LOAD DROPPING
	<b>FUNCTION SYMBOLS</b>		HIGH GAS PRESSURE		<b>PILOT RELAYING SCHEMES</b>
	PHASE OVERCURRENT		LOW GAS PRESSURE		INITIATING - MASTER UNIT (CONTROL CENTER)
	GROUND OVERCURRENT		HIGH TEMPERATURE		RECEIVING - REMOTE UNIT (LOCAL SUBSTATION)
	PHASE OVERCURRENT (INSTANTANEOUS)		LOW TEMPERATURE		NOTE: SUPERVISORY CONTROL OF EQUIPMENT IS SHOWN WITH A LETTER DENOTING THE MASTER UNIT LOCATION, AND AN EXPLANATORY NOTE IS MADE ON THE DRAWING. AN EXAMPLE FOLLOWS.
	GROUND OVERCURRENT (INSTANTANEOUS)		AUTOMATIC RECLOSING (R IN POWER CIRCUIT BREAKER SYMBOL. NUMBERS INDICATE 1-, 2-, 3-, OR 4-SHOT.)		RECEIVING - FROM DITTMER CENTER (D)
	PHASE OVERCURRENT FAULT DETECTOR		CONNECTION		THE LAST LETTER OR ABBREVIATION DENOTES THE CENTER LOCATION.
	PHASE OVERCURRENT - BREAKER FAILURE		NONCONNECTION		
	PHASE OVERCURRENT - MULTIPHASE FAULT DETECTOR				
	PHASE OVERCURRENT - DEAD-LINE FAULT				
	OVERVOLTAGE				
	UNDERVOLTAGE				
	VOLTAGE CONTROL (AUTOMATIC)				
	HOT-LINE CHECK (VOLTAGE)				
	OVERFREQUENCY				
	UNDERFREQUENCY				
	SYNCHRONISM CHECK (FREQUENCY)				
	<b>NONDIRECTIONAL SYMBOLS</b>		<b>DIFFERENTIAL AND MISCELLANEOUS SYMBOLS</b>		<b>SUPERVISORY CONTROL SYMBOLS</b>

FIGURE 20.14 (Continued)

## Electric Power Systems Schematic Symbols and Terminology

**Electrical relays** are magnetic switching devices. **Nondirectional relays** are relays that operate when current flows in either direction. **Directional relays** operate only when current flows in one direction. **Differential relays** provide a switching connection between a circuit with two different voltage values. **Pilot relay** systems are controlled by communication devices and are designated by the type of communication circuit or the function of the relay system. **Supervisory control relays** are used to check, monitor, and control other devices.

### Plot Plan Drawing

The entire layout of a substation is shown by a **plot plan** drawing, also known as a **site plan**. The plot plan is drawn like a map, showing the relationship between the elements of the substation in correct orientation to compass direction. The scale used for the plot plan generally ranges from 1" = 20' to 1" = 50' (1:200, 1:500 metric). Figure 20.15 shows typical plot plan symbols. The items commonly found on a plot plan include:

- Property boundaries and developed-yard boundary with chain link fence or block wall.
- Primary **bearing** lines. Bearing is direction in relation to the northwest or northeast and southwest or southeast quadrants

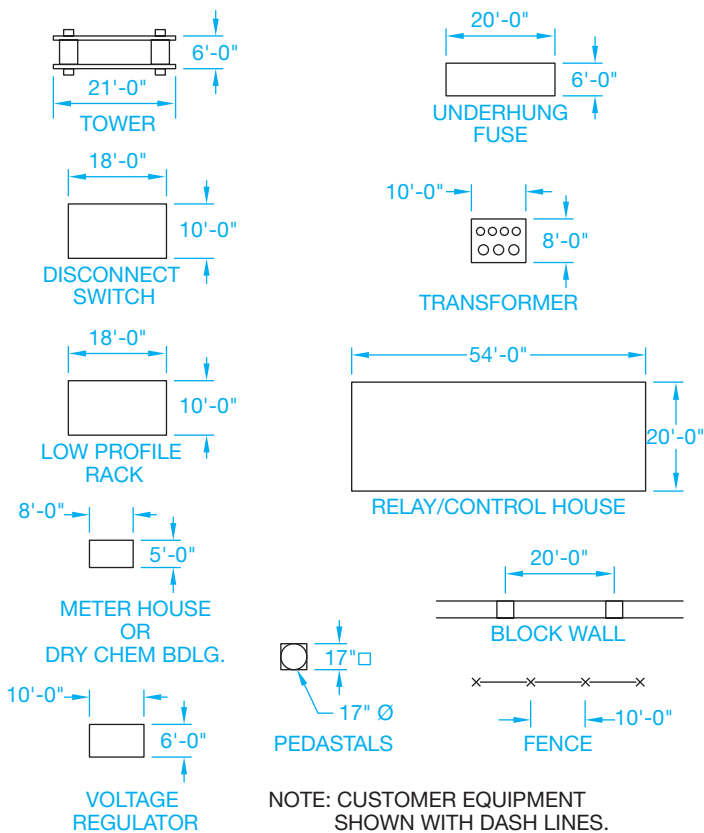


FIGURE 20.15 Plot plan symbols. © Cengage Learning 2012

of a compass. For example, 50°30'15"W is a line that is located at an angle of 50°30'15" toward west from north.

- Service and access roads.
- Buildings and other nonelectric structures.
- System electrical components such as switches, fuses, transformers, and racks.
- Complete dimensioning.

### Bus Layout

A **bus** is an aluminum or copper plate or tubing that carries electrical current. Construction crews use the **bus layout** drawing for the construction of the current-carrying portion of the substation. Bus layout drawings show the system in plan (top) view as shown in Figure 20.16 and in elevation (side) view as shown in Figure 20.17.

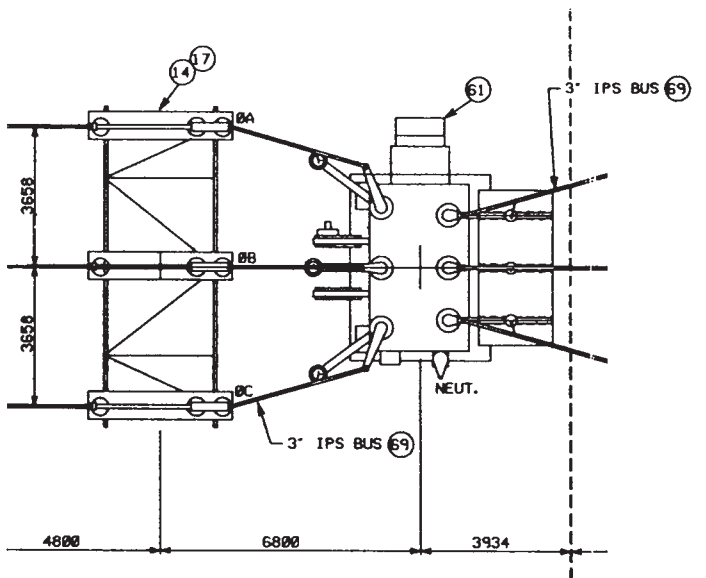


FIGURE 20.16 Layout plan. Courtesy Bonneville Power Administration

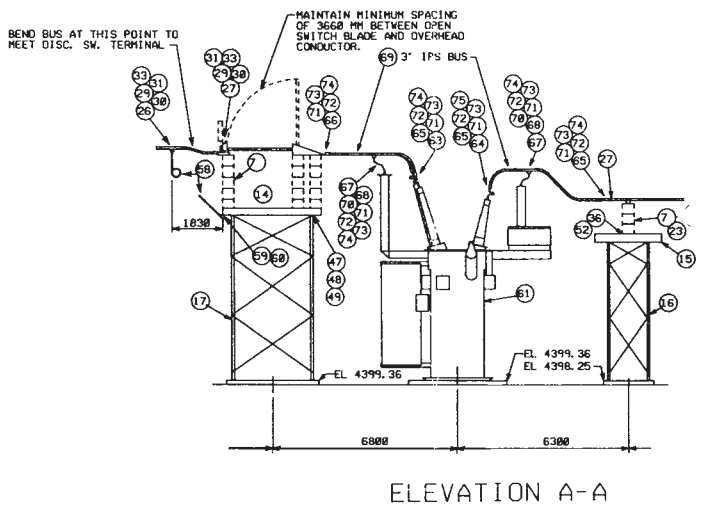


FIGURE 20.17 Bus elevations. Courtesy Bonneville Power Administration



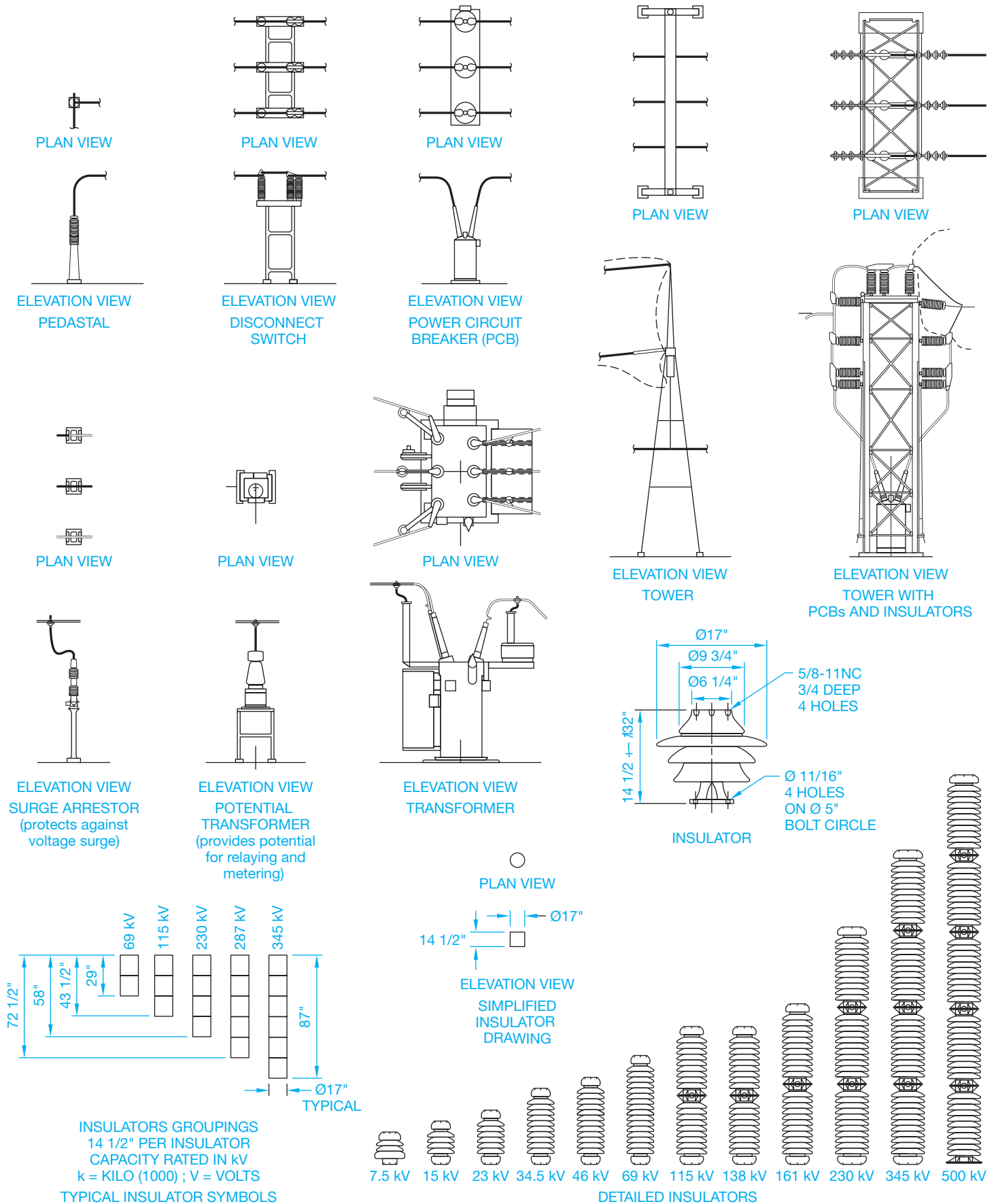


FIGURE 20.18 Common bus layout symbols. © Cengage Learning 2012

Numbered balloons identify the components, which key each item to a bill of materials. Figure 20.18 shows common bus layout symbols.

### Grounding Layout and Details

There is a tremendous hazard in substations because of the possibility of high voltage occurring on pieces of equipment during fault conditions. The voltage at different pieces of equipment varies with the location in the yard and the fault current available. The amount of potential electrical shock depends on the voltages available during a **fault condition**. A fault condition is a short circuit, which is a zero resistance path for current flow. The voltage difference between the metal parts of the equipment and the ground surface on which a person stands must be maintained at a very low level. This is determined by the amount and location of the **ground grid**, which is the grounding system. Grounding layouts are often drawn at a scale of 1" = 10'-0" (1:50 metric) as shown in Figure 20.19.

Grounding details provide an enlarged view of how a structure or piece of equipment grounds. Details key to the grounding layout with letters—for example, DETAIL H1, as shown in Figure 20.20.

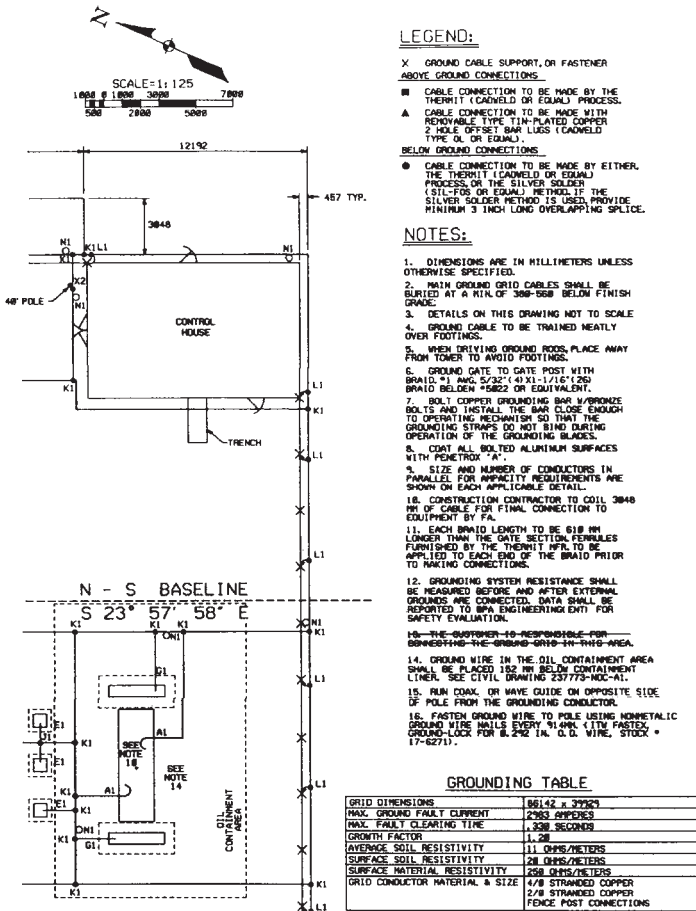


FIGURE 20.19 Grounding layout. Courtesy Bonneville Power Administration

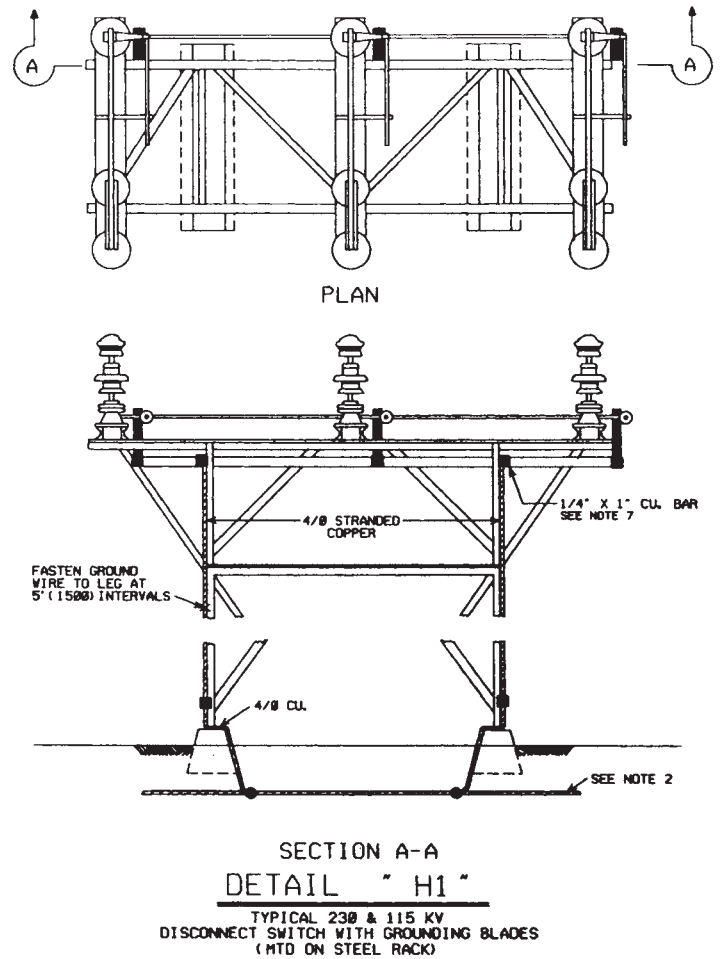


FIGURE 20.20 Grounding details. Courtesy Bonneville Power Administration

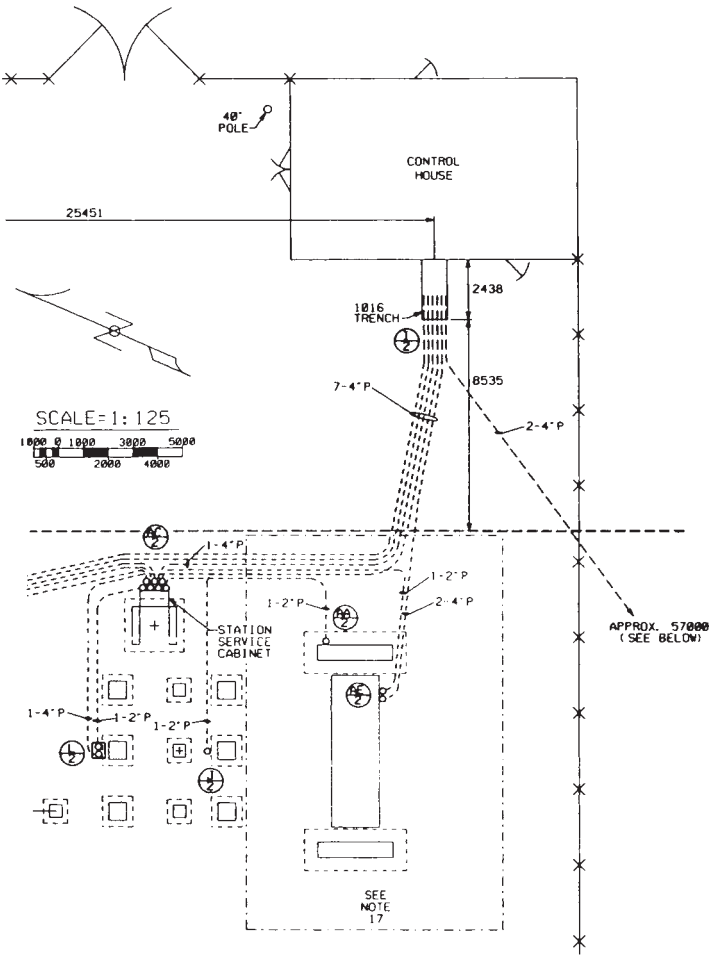
### Conduit Installation Layout and Details

Each component in a substation has a specific function and is a different type of electrical equipment. The relay control house is a building that interconnects each piece of equipment using multiple conductor cables (see Figure 20.21).

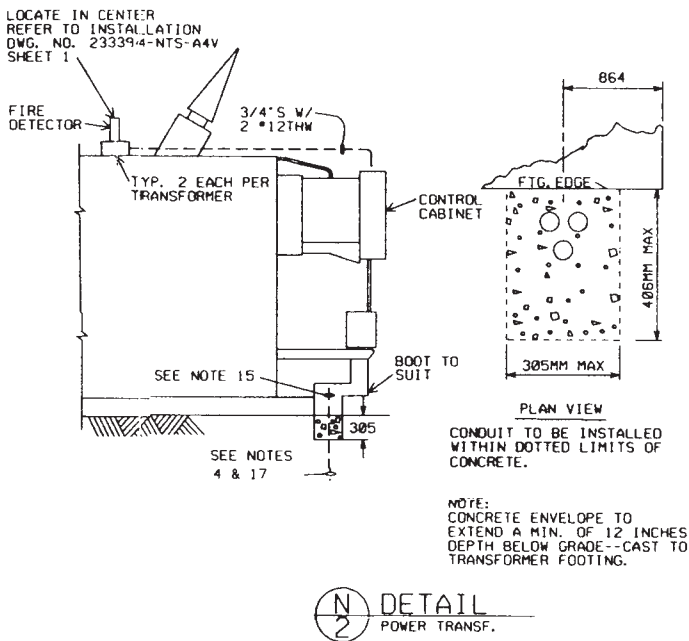
**Conduit detail drawings** coordinate with the layout to provide construction details and locations of various fittings, junction boxes, and brackets. Details correlate to the layout with callouts that give the detail identification and the page where the detail is located—for example, DETAIL N/2. Conduit details are drawn at a scale of 1/2" = 1'-0" (1:20 metric), or they can be drawn without scale (see Figure 20.22). Balloons key components in the drawing to a bill of materials.

### RESIDENTIAL AND COMMERCIAL ELECTRICAL PLANS

The design of the electrical system is an important part of the total livability of a home and the function and safety of a commercial or industrial facility. Careful analysis should be



**FIGURE 20.21** Conduit installation layout drawing. Courtesy Bonneville Power Administration



**FIGURE 20.22** Conduit detail. Courtesy Bonneville Power Administration

given to the design placement of equipment and furniture and the planned use of each room. Local and national electrical codes provide specifications for installations and layout. Layout planning should play an important role with code guidelines. An evaluation of need and code requirements should be closely compared so the electrical layout is not over- or underdesigned.

## Architectural Electrical Symbols

Symbols and lines show the electrical layout in a structure. In residential applications, the electrical layout is often part of the floor plan. Commercial electrical plans are commonly a separate sheet from the base floor plan sheet. Electrical symbols are generally 1/8 in. (3 mm) in height, where applicable. The electrical plan should be drawn in a clear, concise manner so the layout remains uncluttered. All lettering for switches and other notes should be 1/8 in. high, although some companies use a 5/32 in. (4 mm) height. Figure 20.23 shows common electrical symbols.

Switch symbols are drawn perpendicular to the wall and are placed to read from the right side or bottom of the sheet. The switch relay dashed line should intersect the symbol at right angles to the wall or the relay can begin next to the symbol. Do not mix methods throughout the drawing. Verify the preferred procedure with your instructor or employer (see Figure 20.24). Figure 20.25 shows several typical electrical installations with switches to light outlets.

When special characteristics are required, such as a specific size of fixture, a location requirement, or any other specification, apply a local note next to the electrical symbol to describe the situation (see Figure 20.26). Use general notes when a specification affects electrical installations on the entire layout. Figure 20.27 shows some common errors related to the placement and practice of electrical floor plan layout.

## Residential Electrical Plan Examples

Residential electrical plans are generally less complex than commercial plans. Figure 20.28 shows some maximum spacing recommendations for installation of wall outlets in a residential structure. Figure 20.29 shows a typical residential electrical layout. Figure 20.30 shows a typical kitchen layout.

**NOTE:** Refer to *Architectural Drafting and Design* by Jefferis and Madsen, Cengage Learning, for complete architectural drafting and design applications.

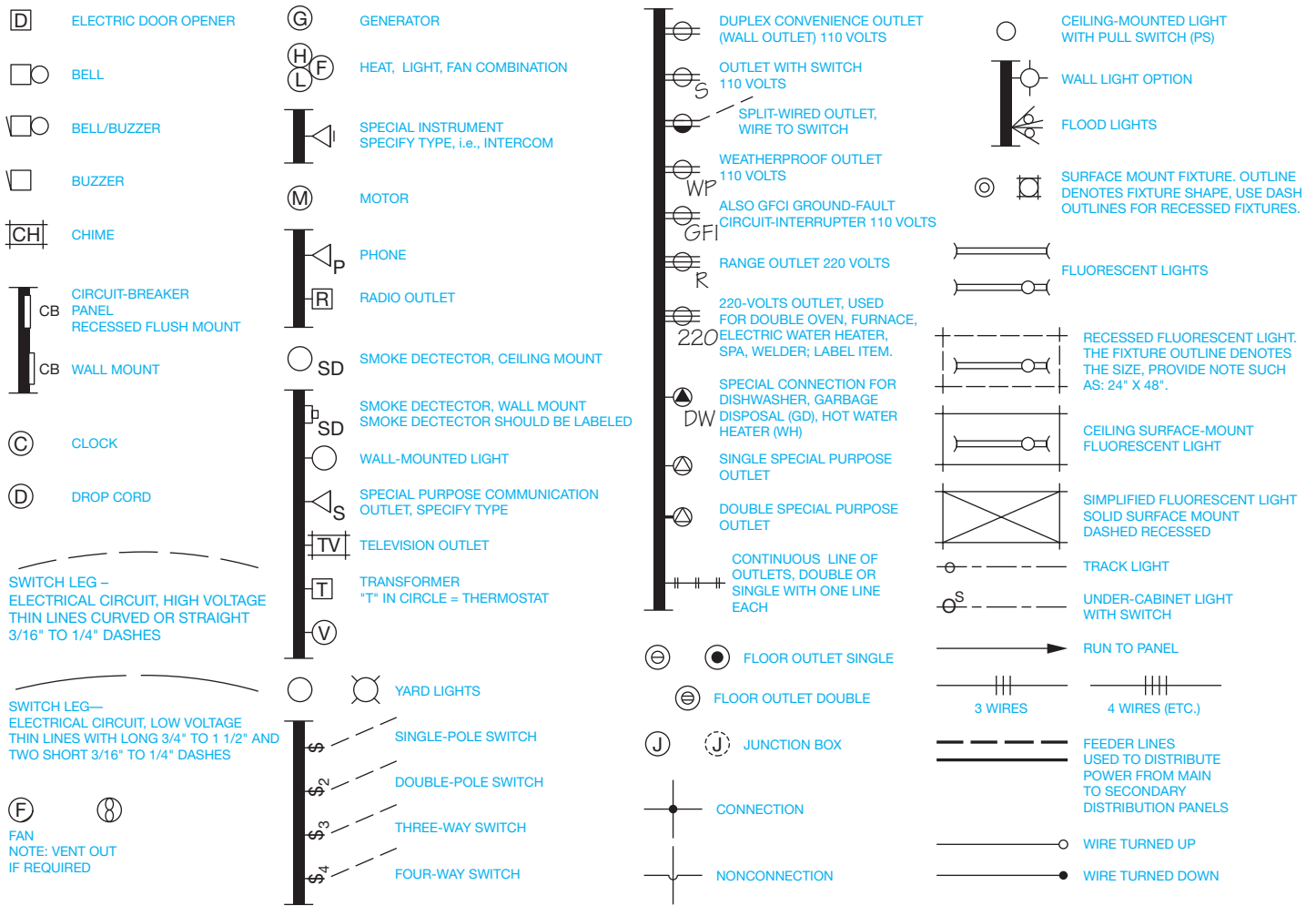


FIGURE 20.23 Common floor plan electrical symbols. © Cengage Learning 2012

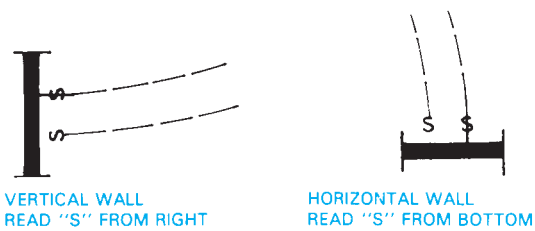


FIGURE 20.24 Switch symbol placement.

## Commercial Electrical Plan Examples

Commercial electrical plans often follow much more detailed installation guidelines than residential applications. Separate electrical plan sheets are commonly used, so the only information provided is that of electrical installations.

The electrical circuit switch legs for commercial applications are generally drawn as solid lines rather than as dashed lines as in residential electrical plans. The electrical circuit lines that continue from an installation to the service distribution panel are terminated next to the fixture and capped with an arrowhead, meaning that the circuit continues to the distribution panel. When multiple arrowheads are shown, this indicates the number of circuits in the electrical run (see Figure 20.31). For many installations in which a number of circuit wires are used, the number of wires is indicated by slash marks placed in the circuit run. The number of slash marks equals the number of wires (see Figure 20.32).

There can be more than one commercial electrical sheet—for example, floor plan lighting, electrical plan power supplies, or reflected ceiling plan. The **floor plan lighting layout** provides the location and identification of lighting fixtures and circuits. The floor plan lighting layout is usually coordinated with a **lighting fixture schedule** that provides a list of the light fixtures used in the building, as shown in Figure 20.33. In some applications, a **power-supply plan** is used to show all electrical outlets, junction boxes, and related circuits (see Figure 20.34).

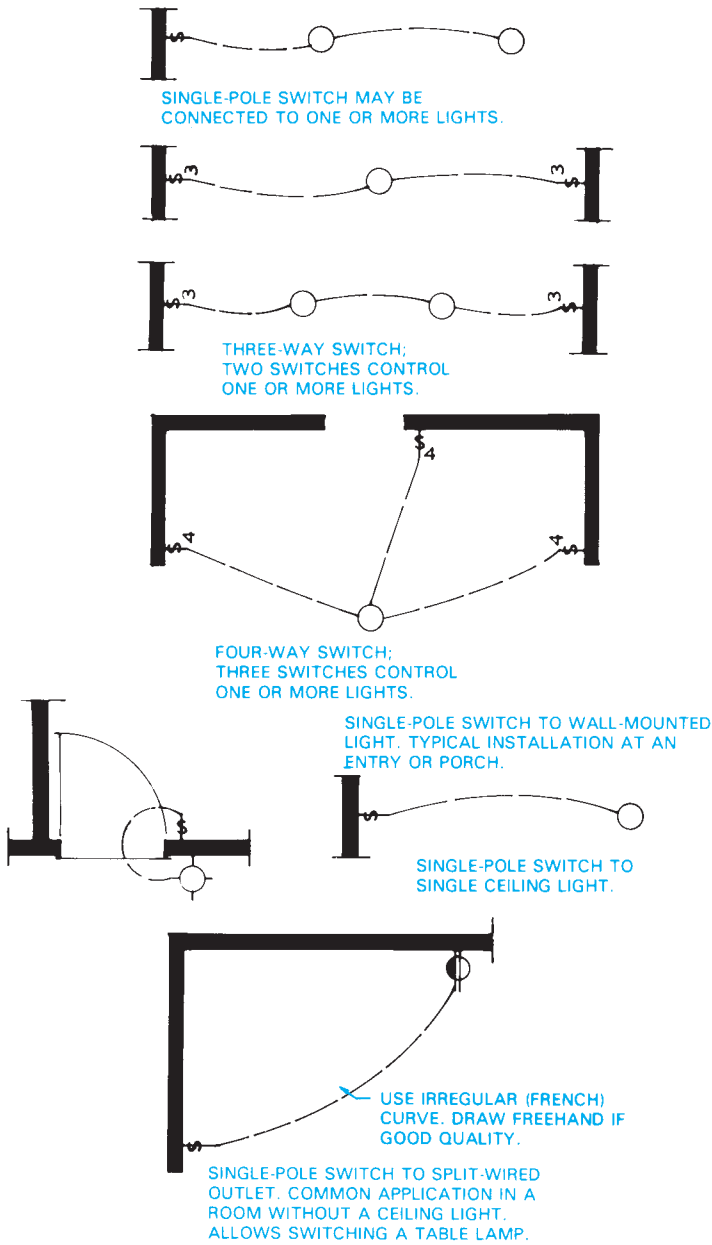


FIGURE 20.25 Typical electrical installations. © Cengage Learning 2012



FIGURE 20.26 Special notes for electrical fixtures. © Cengage Learning 2012

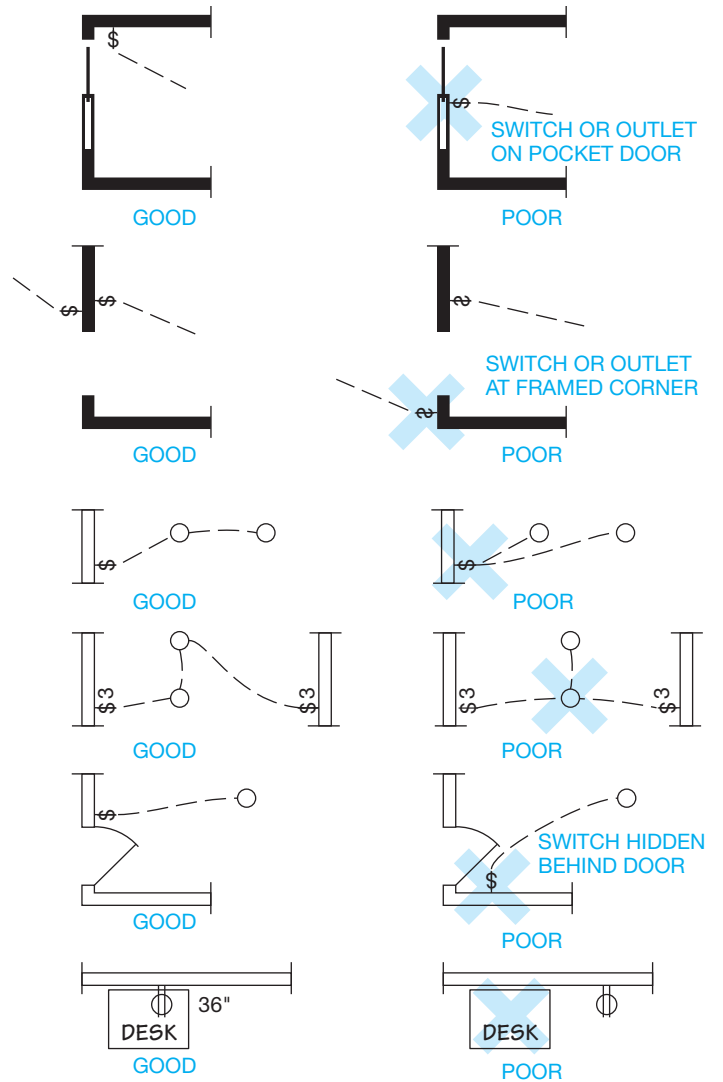


FIGURE 20.27 Electrical floor plan layout techniques. © Cengage Learning 2012

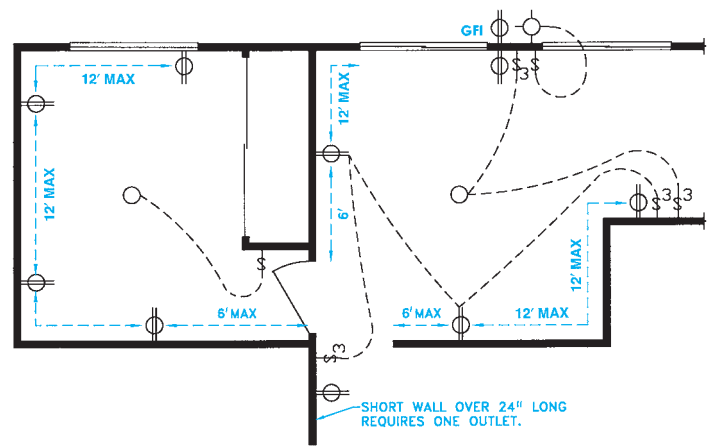


FIGURE 20.28 Maximum spacing requirements. © Cengage Learning 2012

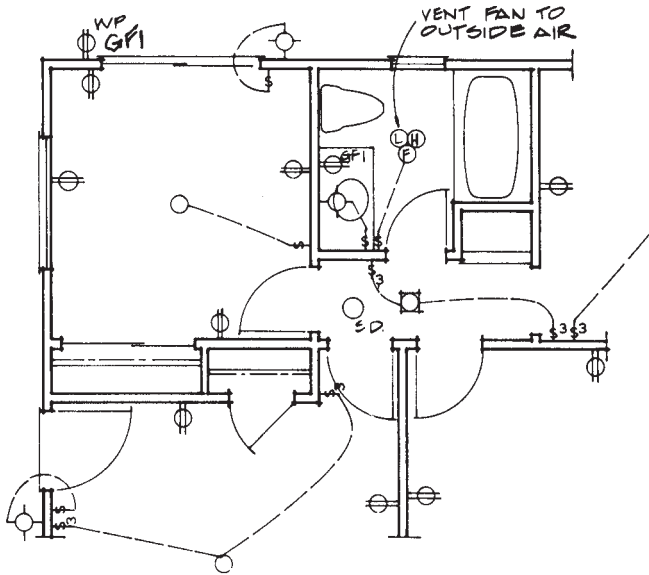


FIGURE 20.29 Typical electrical layout.

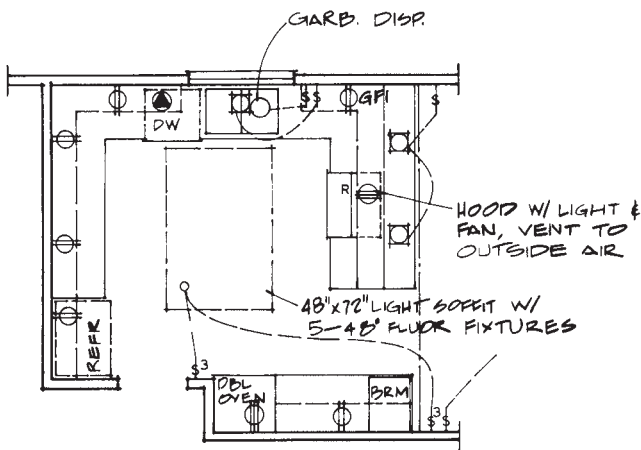


FIGURE 20.30 Kitchen electrical layout.

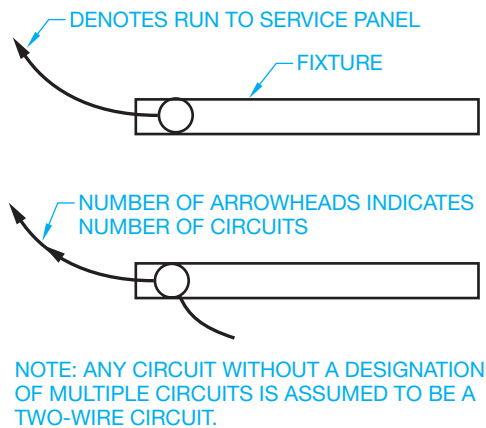


FIGURE 20.31 Electrical circuit designations.

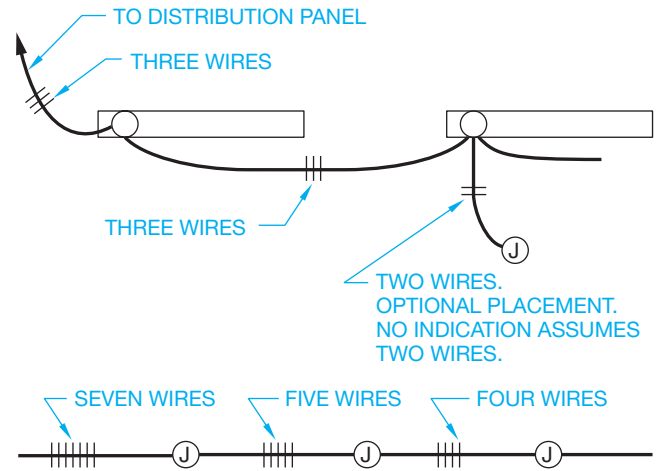


FIGURE 20.32 Number of wires designated in circuit runs.

LIGHTING FIXTURE SCHEDULE

- F1 – Surface mounted 8’ open strip fluorescent. Lamps: (1) F96T12/LW/WM (75 watt). Manufacturer: Lithonia PUN 196 – 120V
- F2 – Surface mounted 8’ open strip fluorescent with damp location label and low temperature ballast. Lamps: (1) F96T12/LW/WM (75 watt). Manufacturer: Lithonia PUN 196 – DL – 120V
- F3 – Surface mounted 4’ open strip fluorescent. Lamps: (2) F48T12/LW/WM (30 watt). Manufacturer: Lithonia PUN 248 – 120V
- F4 – Surface ceiling mounted vapor-tight incandescent with cast guard. Lamp: (1) 100W A19 Manufacturer: Steno QVCXL–11GC
- F5 – Surface mounted incandescent with prismatic lexan cylinder and damp location label. Lamp: (1) 100W A19 Manufacturer: Marco QB5NP – SA
- F6 – Surface well mounted sodium vapor security flood light. Lexan lens and weather tight. Lamp: 70w Manufacturer: Croushinds Sc – 711 – 70W HPS
- F7 – Recessed ceiling mounted incandescent fan/light combination. Lamp: 10w Manufacturer: Broan Q678
- F8 – 16’ pole mounted sodium vapor flood area luminaire. Type III distribution flat lens. Bronze finish. Pole to be 16’ straight square steel. Coated with paint to match fixture. See detail. Lamp: LU150 – 55 Manufacturer: ELSCO ZCHL – 150 – MPS – 16 – DP – 120 – B2A Alternate: Nu-Art QULT – III – MPS – 150

FIGURE 20.33 Lighting needs are shown using an overlay of the floor plan and a lighting fixture schedule. 7-Eleven, Inc.

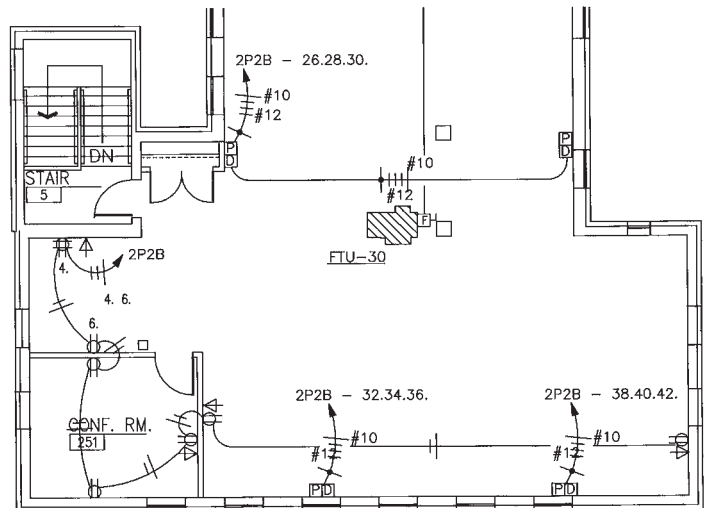


FIGURE 20.34 Power-supply plan. Courtesy System Design Consultants

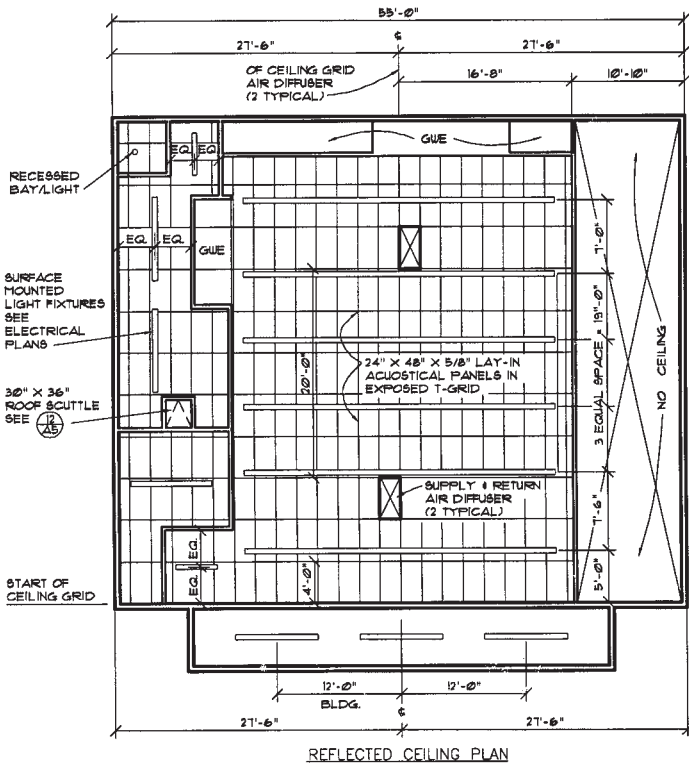


FIGURE 20.35 A reflected ceiling plan to show the suspended ceiling layout. 7-Eleven, Inc.

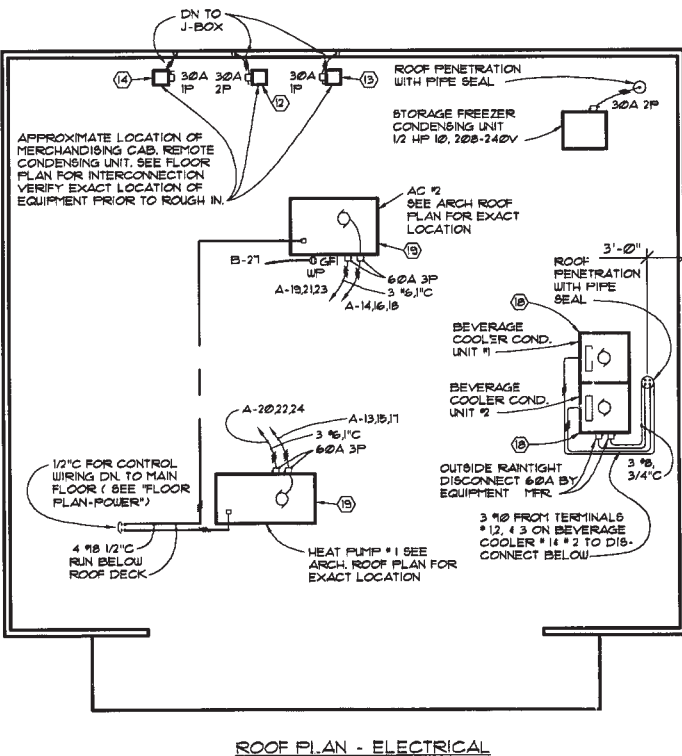


FIGURE 20.36 To supplement the power-supply and lighting plan, a plan showing the electrical needs of equipment on the roof is also drawn. 7-Eleven, Inc.

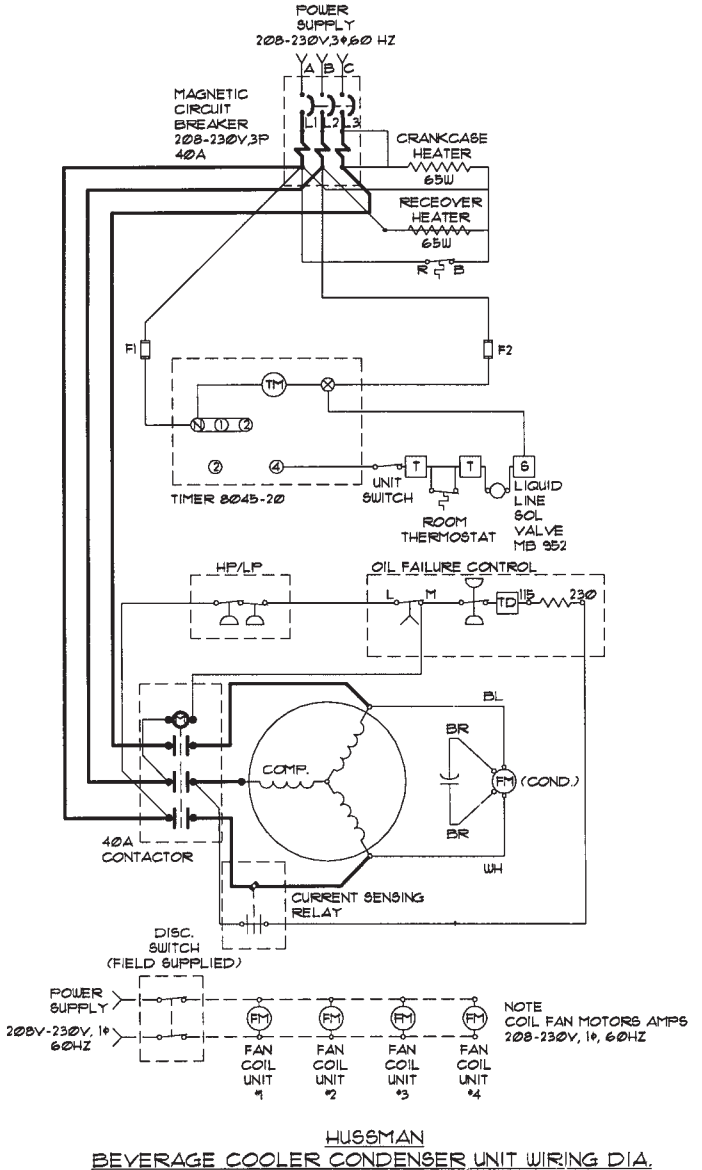


FIGURE 20.37 Schematic wiring diagrams for specific applications. 7-Eleven, Inc.

The **reflected ceiling plan** is used to show the layout for the suspended ceiling system as shown in Figure 20.35. Electrical plans for equipment installations can also be needed to supplement the power-supply and lighting plans. Figure 20.36 shows the plan for roof installation of equipment. You are also often required to draw schematic diagrams for specific electrical installations as shown in Figure 20.37.

## GREEN TECHNOLOGY APPLICATION

### ELECTRICITY GENERATION FROM WIND POWER

The following information was taken, in part, from the Southwest Windpower Web sites located at [www.windenergy.com](http://www.windenergy.com) and [www.skystreamenergy.com](http://www.skystreamenergy.com). Skystream 3.7<sup>®</sup>, developed by Southwest Windpower in collaboration with the United States Department of Energy National Renewable Energy Laboratory (NREL), is the newest generation of residential wind technology. Skystream is the first all-inclusive wind generator with built-in controls and inverter designed specifically for utility grid-connected residential and commercial use.

### RESIDENTIAL WIND POWER ELECTRICITY GENERATION

Skystream is a small wind generator that allows home and business owners to harness the free power of the wind and take control of their energy bills like never before. Early adopters have reported a savings of more than 50% on their energy bills. Figure 20.38 shows the Skystream 3.7.

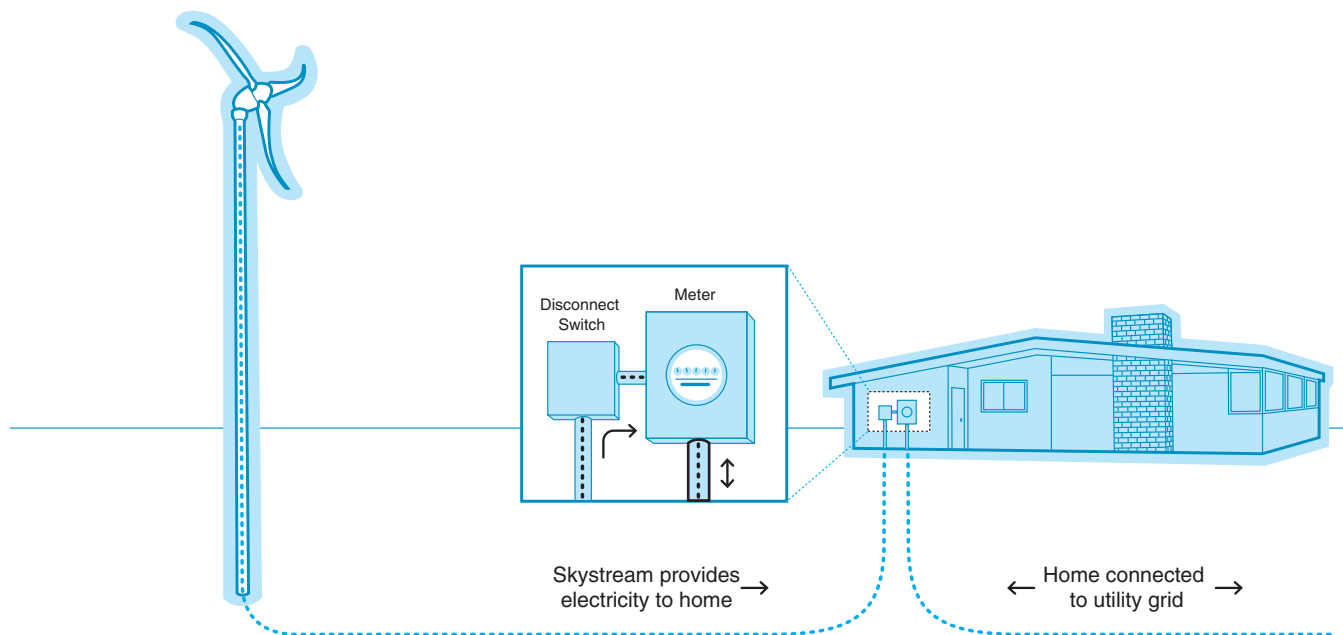
#### Specifically for Grid Connectivity

The Skystream is specifically designed for utility grid-connected homes and businesses. In certain states, consumers can take advantage of net metering, which is the sale of unused energy back to the power grid as shown in Figure 20.39.



Courtesy Southwest Windpower

**FIGURE 20.38** The Skystream 3.7 is the first residential, utility grid-connected small wind power turbine designed for residential use and commercial applications.



**FIGURE 20.39** How the Skystream 3.7 wind power electricity generator works. Courtesy Southwest Windpower



## How the Skystream Works

Skystream offers a simple, all-in-one solution for harnessing wind energy on a residential scale. Different from all other technologies, Skystream 3.7 is the first all-inclusive wind generator with built-in controls and **inverter**. An inverter is an appliance used to convert independent DC power into standard household AC current. During installation, the Skystream is connected to the electric meter, and nothing else changes inside the home. The Skystream works together with the electric utility to power the home or business. The utility company supplies electricity when the wind is not blowing. When there is wind, the Skystream provides clean, quiet electricity. When the Skystream generates more electricity than needed, the meter can spin backward, which means you are selling electricity back to the utility company.

## Energy Production in Exceptionally Low Wind Speeds

Designed for low wind speeds, Skystream 3.7 has a 2.4 kW rating and begins producing power in an 8 mph (3.5 m/s) breeze with full output achieved at 20 mph (9m/s). To determine the average wind speed in your area, search the Internet with key phrases such as “determine the average wind speed in your area.”

## Low Profile

Skystream was designed to blend in with its surroundings. When mounted on towers ranging from 33 to 60 ft (10.6–18.3 m), it has little visual or audible impact on its surroundings. Towers up to 110 ft (33.5 m) are also available. A site assessment is important to determine the best tower height for your specific site locations.

## Quiet Operation

The Skystream is exceptionally quiet during operation. In fact, Skystream's sound is unrecognizable over trees blowing in the wind. The sound pressure level generated by Skystream is in the range of 40 to 50 decibels, which is quieter than background noise in a home or office.

## RESIDENTIAL WIND POWER INSTALLATION

Southwest Windpower recommends installing Skystream 3.7 at sites with the following criteria:

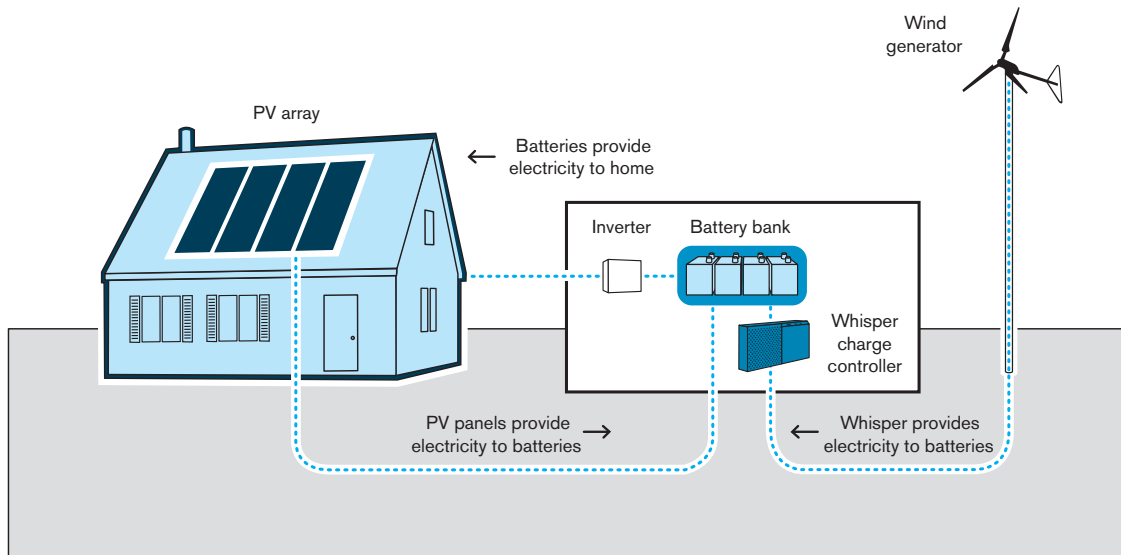
- Adequate wind resource. Minimum average wind speed for Skystream 3.7 is 10 mph (4.5 m/s). Ideal sites have 12 mph (5.4 m/s) or greater average wind speed.
- Site free from obstructions. Clean, unobstructed wind is best for Skystream 3.7. The top of the tower should be a minimum of 20 ft (6 m) above any surrounding object within a 300 ft (91.5 m) radius. Although the machine can be installed on smaller lots of land, properties of one acre or more are typically ideal and generally have unobstructed wind.
- Suitable zoning. Tower installation must comply with local zoning regulations. It is also advisable to make sure there are no home owner association (HOA) regulations that prohibit the use of towers.
- Interconnection with utility. The local utility must allow for interconnection. The 1979 federal PURPA act requires that small systems be allowed to connect to the electrical grid, but homeowners should consult their local utility.
- Electricity cost of \$0.10/kWh or greater. Consumers should consult with their local utility or look at their electric bills.

## REMOTE WIND POWER GENERATOR INSTALLATIONS

The Southwest Windpower Whisper and AIR Series generators provide dependable energy for remote homes, telecommunications sites, water pumping, and other rural applications in moderate to extreme environments. Whisper generators provide direct current to batteries, which store the energy until it is needed. Standard residential alternating current appliances can be used if the power is run through an inverter before use. The AIR series generator incorporates a microprocessor-based technology for increased performance, improved battery charging capability, greater reliability, and reduced noise. Figure 20.40 shows how the remote wind power electric generator works.

## TAX INCENTIVES FOR WIND POWER GENERATORS

Depending on the tower and installation costs, wind speed average, rebates, and local electricity costs, the Skystream 3.7 can pay for itself in as little as five years. The Emergency Economic Stabilization Act of 2008 includes a federal-level tax credit for qualified small wind turbines, including consumers who purchase Skystream 3.7. Check with your tax adviser to confirm the availability in your area.



**FIGURE 20.40** How the remote wind power electric generator works. *Courtesy Southwest Windpower*

## PROFESSIONAL PERSPECTIVE

The responsibilities of the electrical drafter are varied, depending on the electrical needs of the client or employer. This chapter has touched on the basics of electrical drafting as related to electrical power systems and residential and commercial electrical applications. Engineering drafting related to these fields requires practical experience associated with the specific engineering needs of the company.

In addition to a thorough understanding of company requirements, you must know electrical terminology and how the components go together. It is important for an engineering drafter in the electrical engineering business to visualize electrical systems and understand electrical clearance requirements. Schooling in descriptive geometry, communication skills, and problem-solving techniques, along with electrical theory and practices, is essential.

When you go to work in this field, you will find that it is extremely important that you check your work completely, making sure that electrical connections made are necessary. A systematic method of checking your own work is recommended. This method involves running a print of your drawing and then marking the print with a colored pencil to compare it to the original engineer's sketch or job assignment. You will find that a complete set of drawings for a project develops from one to the next. Beginning with the single-line diagram, each stage of project development becomes more specific. The checking process continues as an evolutionary process until all of the required drawings are complete. With each stage, checking and accuracy become more critical. There are many tools available in modern electronics design analysis products to help eliminate circuit errors and to ensure correct design.

## ELECTRONIC DRAFTING

**Electronics** is the control of electrons for use in devices that are dependent on low voltage, amperage, and signal paths. The electronics industry typically refers to electronic drafters as technicians. The responsibility of a technician is to convert engineering sketches or instructions to formal drawings or to revise existing drawings. This task requires that drawings be prepared in a neat, organized manner using proper symbols. It is advisable for technicians to become familiar with the fundamentals of electronic technology. As a technician gains experience in the electronics industry, an in-depth knowledge of product function becomes important for advancement into design and engineering.

## ELECTRONIC DIAGRAMS

Many of the same types of diagrams used in electrical drafting are used in electronic drafting. There is only a slight difference between the appearance of electrical and electronic drawings. This text separates the two areas because of the specialized difference that exists between electrical power transmission systems and intricate electronic systems.

### Block Diagrams

A block diagram outlines the path of a signal through a series of steps or operations. The purpose of block diagram drawings is

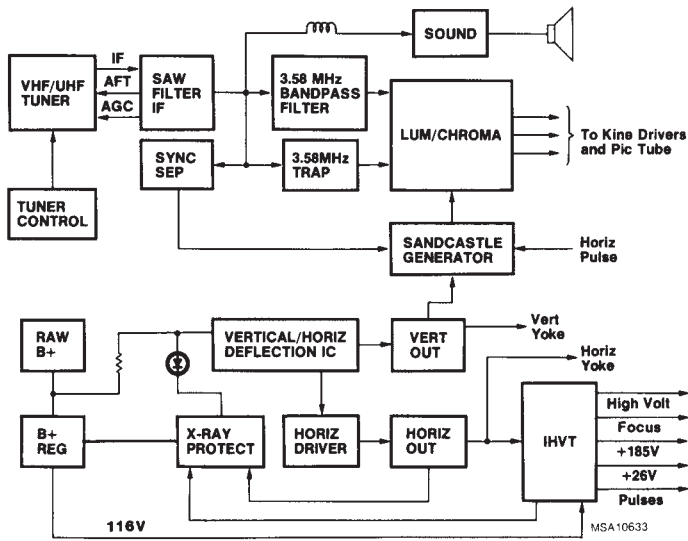


FIGURE 20.41 Block diagram. Courtesy RCA Consumer Electronics

to provide a quick interpretation of the relationship between the different components in electronic equipment. Blocks show the steps or operations, which summarize a schematic drawing by omitting the details. A square or rectangular block is the usual basic symbol used in block diagrams. The largest title going into the block determines the size of the block, such as CONVERTER or AMPLIFIER. The block diagram should start in the upper-left corner of the drawing, and the components read from left to right, as shown in Figure 20.41. Graphic symbols are often used to demonstrate input and output devices, such as microphones, and antennas, as shown in Figure 20.42.

You may receive a schematic diagram in which the engineer has clearly defined the components to place in the block diagram. Designers in this field are able to determine the block

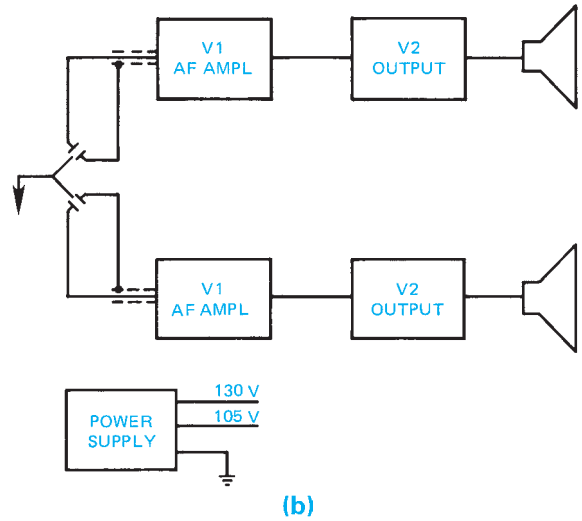
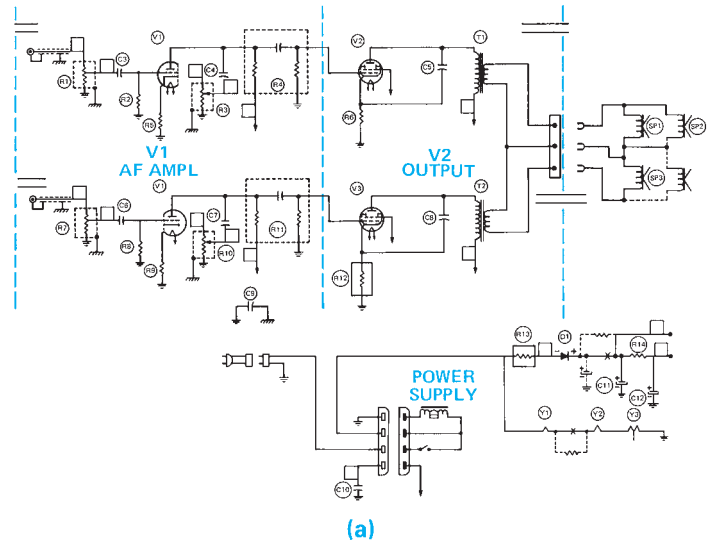


FIGURE 20.43 (a) Schematic diagram is converted into (b) a block diagram. © Cengage Learning 2012

diagram elements directly from a given schematic diagram. Figure 20.43 shows a block diagram prepared from a schematic diagram. In some situations, you may prepare a block diagram from a pictorial diagram, as shown in Figure 20.44. Separate or optional components can be represented with a dashed line.

### Schematic Diagrams

Preparation of a schematic diagram is typically the first stage of product development. Schematic diagrams provide the basic circuit connection information for electronic products. Components of the electronic system are often drawn in stages that represent the function of the device. Individual components are labeled with reference designations, values, and supplier identification. Reference designations tie the component directly with the schematic drawing. A reference designation is a letter, or letters, identifying a component, as follows:

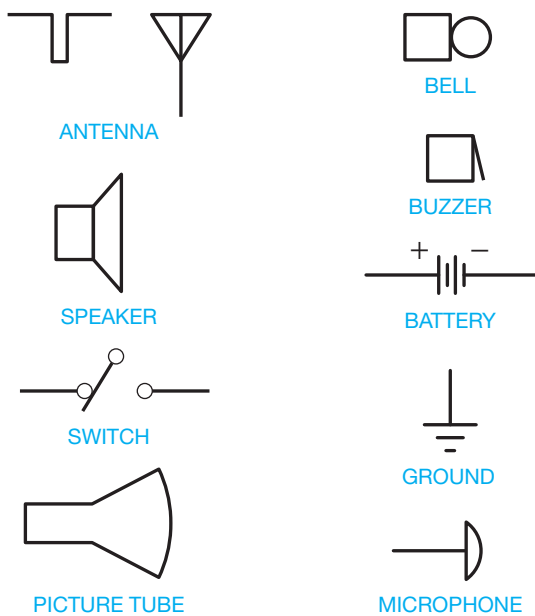


FIGURE 20.42 Graphic symbols for block diagrams. © Cengage Learning 2012

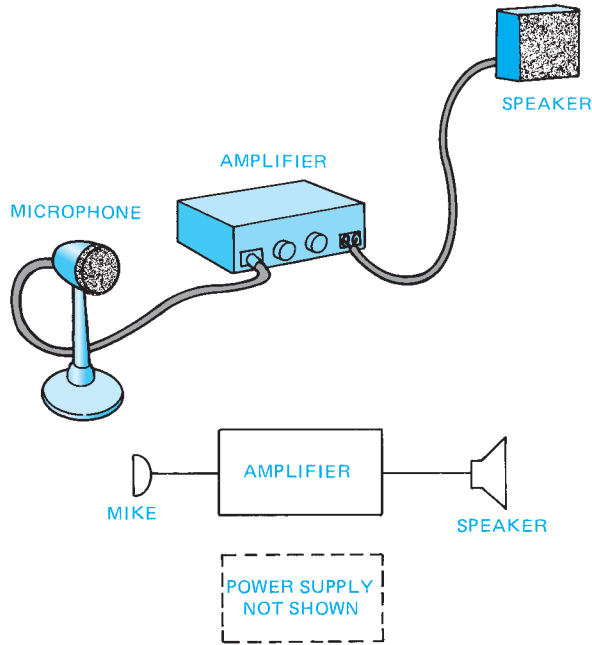


FIGURE 20.44 Block diagram from a given pictorial drawing and optional components shown with dashed lines.

Component	Reference Designation
Capacitor	C
Inductor	L
Resistor	R
Diode	D
Transistor	Q
Transformer	T
Switch	S
Semiconductor	CR
Integrated circuit	U

You should know the product well enough to prepare schematics that are uncluttered and easy to read, follow standards, fit the size and shape of the product, and are technically correct. The following discussion provides enough electronic information to help you prepare a basic schematic.

### Basic Electronic Symbols

The symbol and a brief definition of the following components are provided only for general information. A full understanding of function requires technical training.

- **Capacitor—C.** A simple capacitor consists of two metal plates with wire connectors separated by an insulator. A capacitor in an electronic circuit opposes a change in voltage and stores electronic charge (see Figure 20.45).
- **Coil or Inductor—L.** A coil or inductor is a conductor wound on a form or in a spiral that has inductive properties. Inductance is the property in an electronic circuit that opposes a change in current flow or where energy is stored in a magnetic field, as in a transformer (see Figure 20.46).

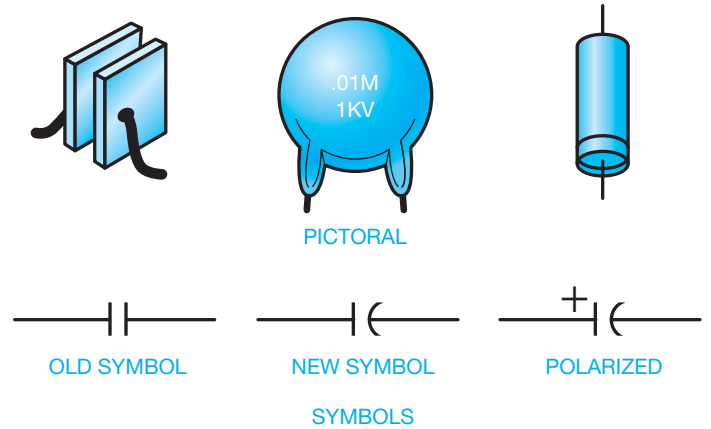


FIGURE 20.45 Capacitor symbols. © Cengage Learning 2012

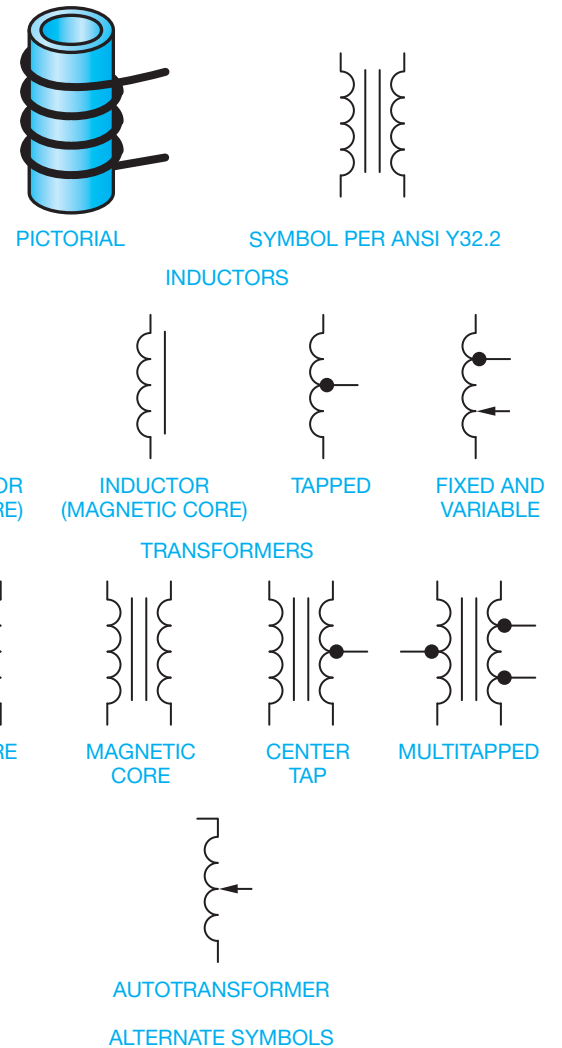


FIGURE 20.46 Coil (inductor) symbols.



FIGURE 20.47 Resistor symbol. © Cengage Learning 2012

- **Resistor—R.** Resistors are components that resist the flow of electricity. They are used in applications where the circuit requires protection by reducing the flow of current. Resistors are available in fixed or variable values. Variable resistors allow the user to adjust the resistance. An example of a variable resistor is the volume control of a radio. Figure 20.47 shows an example of a resistor.
- **Semiconductor—Q, D, or CR.** A simplified definition of a semiconductor is a device that provides a degree of resistance in an electronic circuit. There are various kinds of semiconductors used in electronics. Specific types of semiconductors are diodes, transistors, and others that are discussed later in this chapter. Under certain conditions, these devices allow the current to pass through them freely; under other conditions, they block the flow of current. The simplest semiconductor device is the diode (see Figure 20.48).

Semiconductor symbols picture the basic characteristics of the device. The arrow points in the direction in which conventional current flows. The arrow and bar are present in some form in almost all semiconductor symbols. The bar end of the diode is referred to as the **cathode** or negative side. The direction the symbol arrow points is important to the drafter and may be the only difference in the symbol for two different components. Figure 20.48 is not a complete illustration of semiconductor devices, but it does show how slight changes are used to indicate different components.

### Symbol Variations

An arrow through or to a symbol changes the component from a **fixed-value** device to a **variable-value** device (see Figure 20.49). A screwdriver symbol added to a schematic tells the technician that the component has a variable value by service adjustment, as shown in Figure 20.50. Another group of symbol variations exists in coils, as shown in Figure 20.51.

### Symbol Sizes

The actual size of symbols can vary slightly from one company or CADD software program to another. The uniformity of symbols within a drawing is important. Figure 20.52 shows the recommended sizes of commonly used electronics symbols based on the drawing text height.

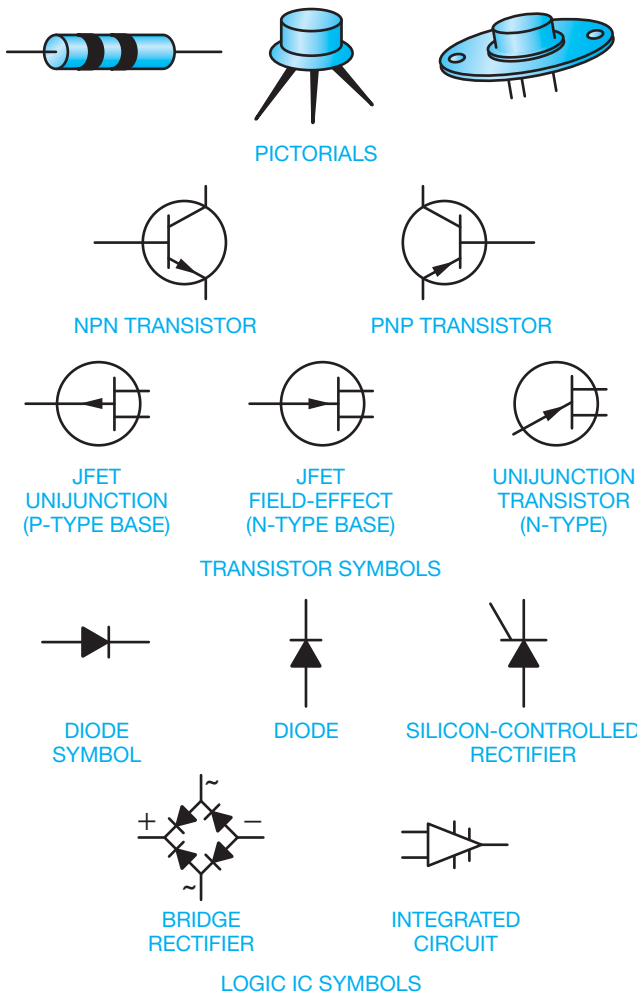


FIGURE 20.48 Semiconductor symbols. © Cengage Learning 2012

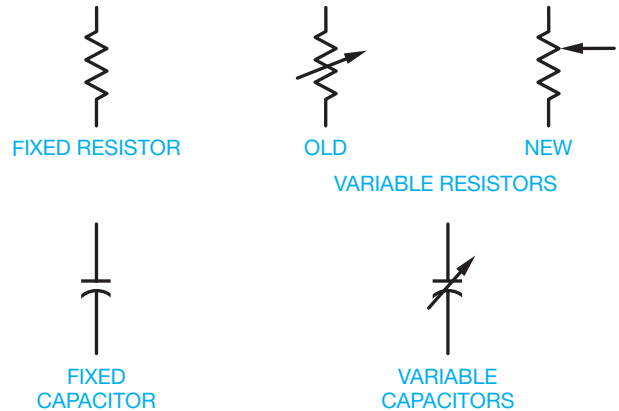


FIGURE 20.49 Fixed and variable component symbols.

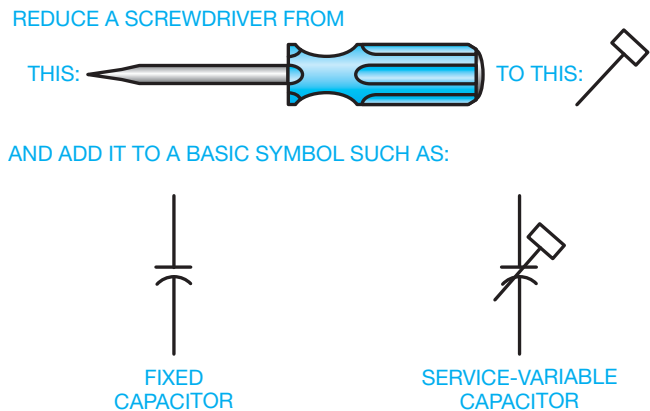
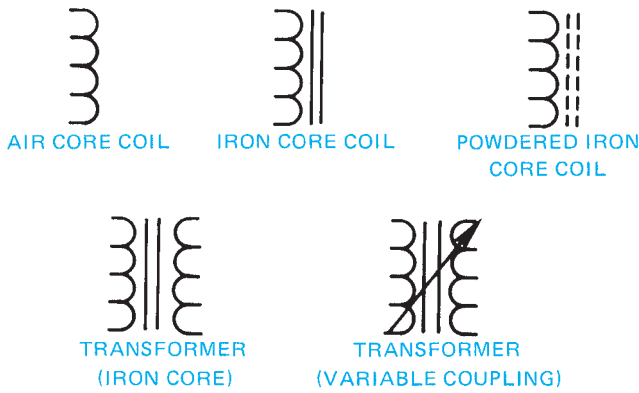


FIGURE 20.50 Fixed and service-variable component symbols.

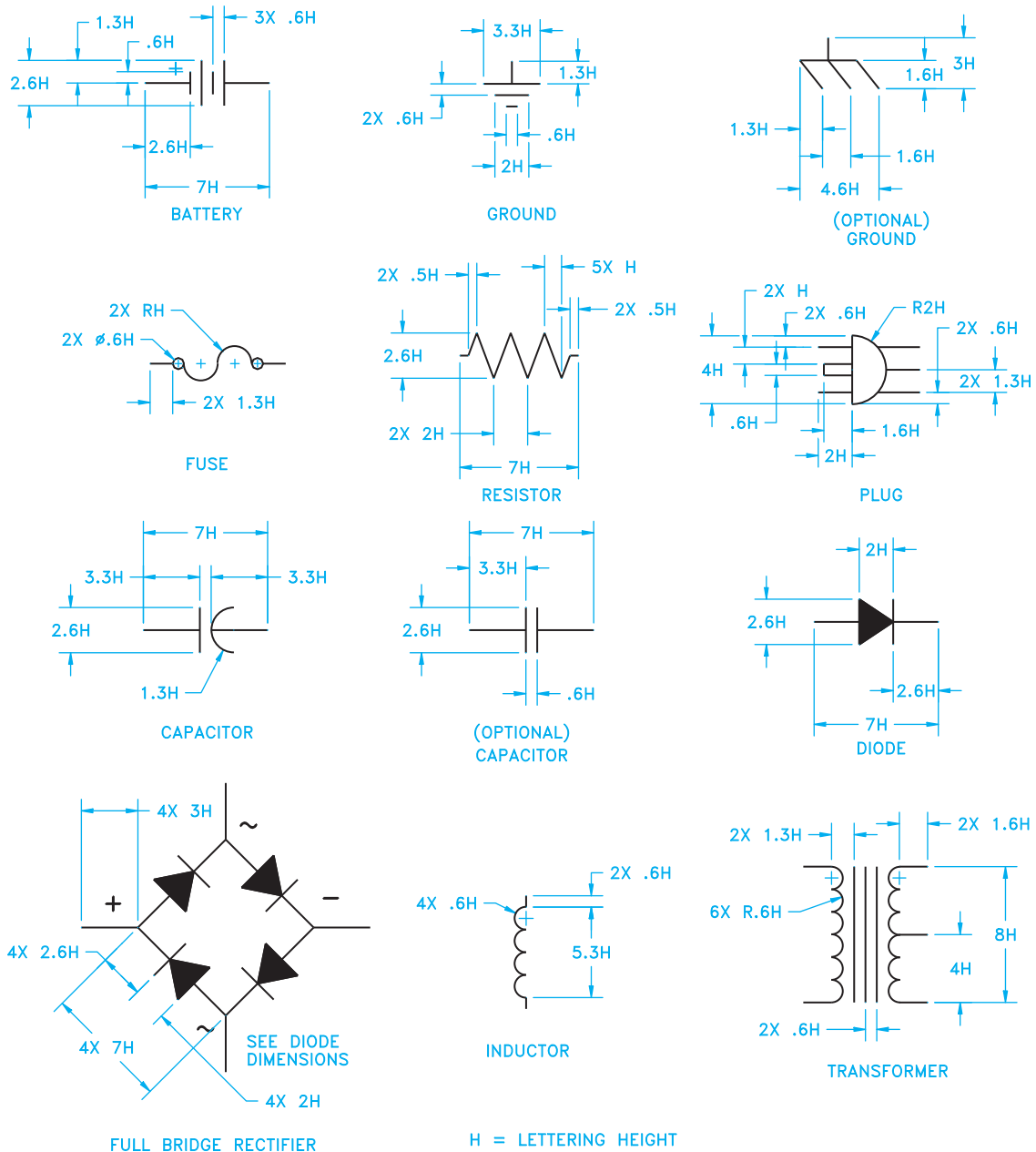


STANDARDS

**IEEE** You need to be very familiar with standard symbols because engineers usually have operational problems on their minds and not the quality of drawings and sketches. Keep a copy of IEEE 315, *Graphic Symbols for Electrical and Electronic Diagrams*, or the company standards handy for reference. When using CADD, a symbol library or a template designed to IEEE standards is an excellent drafting aid.

As an electronic drafter, you may be working from rough engineering sketches. The following are some sample potential communication problems that can occur with rough sketches.

FIGURE 20.51 Coil symbol variations.



H = LETTERING HEIGHT

FIGURE 20.52 Recommended sizes of commonly used electronics symbols based on drawing text height.



FIGURE 20.53 Confusing symbol sketch. © Cengage Learning 2012

- Know current standards so if the symbol  $\text{⊥}$  is on a sketch, you know it is an old symbol of an electrical application for a capacitor.
- Question symbols with odd details such as the symbol in Figure 20.53. Does the line across the bottom of the resistor mean something special, or was the engineer's pencil resting on the paper? In this case, it could mean either, but be careful because it could symbolize a variable resistor with a stop on the adjustment that does not allow the resistor to go all the way to zero. If in doubt, ask the engineer for clarification. It is best not to guess.

### Correct and Incorrect Applications for Schematic Diagrams

There are varieties of electronic drafting techniques that are more acceptable than others. Although there are some methods that the beginning drafter should learn, there can be some situations when common applications change because of a given situation or a difference between national and company standards. Figure 20.54 shows examples of recommended and incorrect applications.

### Active Devices

An **active device** is an electronic component that contains voltage or current sources, such as a **transistor** and integrated circuit. Transistors are *semiconductor* devices in that they are conductors of electricity with resistance to electron flow and are used to transfer or amplify an electronic signal. The key to the schematic layout is the location of the active devices. When schematics are designed, the active devices are often established first. Follow the engineering sketch as a guide for overall size and layout balance and begin the schematic diagram by positioning the active devices. Inputs are usually on the left, and outputs are on the right. Signal flow is across the device from left to right.

### Bias Circuitry

**Bias** is the voltage applied to a circuit element to control the mode of operation. Bias may be fixed, forward, or reversed. The basic circuitry that makes any electronic device function is known as the **DC biasing**. The configuration of this basic circuit is resistors that are connected to an active device. Resistors are components that maintain resistance to the flow of an electric current. The resistors should be placed as closely as possible to the active device without crowding or otherwise destroying the

balance of the drawing. Resistors are normally placed vertically in the schematic, as shown in Figure 20.55. Transistors may be drawn one of two basic ways, depending on the bias direction by changing the arrow direction, as shown in Figure 20.56. After establishing the active devices on the drawing sheet, the next step is to add the resistors. Figure 20.57 shows common bias arrangements for transistor circuits.

### Coupling Circuitry

After establishing the bias circuitry, the next step is generally the layout of the **coupling circuitry**. Coupling circuitry is connections between components and is the point where each schematic becomes unique. The drafter's goal is to provide adequate space for all of the information while keeping the schematic compact and readable.

### Schematic Layout Sketching

Now that some fundamental guidelines have been provided for the **schematic diagram layout**, it is time to make a layout sketch. Sketching on graph paper helps in estimating the space required for component labels and values. You often work from an engineer's design sketch. This sketch can be rough, but gives the layout characteristics, as shown in Figure 20.58. The engineering sketch can be difficult to read and interpret. For example, notice in Figure 20.58 the screened area where the lines cross. These crossing lines represent a question that you should answer. Is there a connection at this point or do the lines cross without making a connection? In this case, the resistors are part of the universal bias pattern as previously discussed, so you can conclude that a connection is intended. Figure 20.59 shows the standard representations for connections and nonconnections. If there is any doubt about how to interpret the engineer's sketch, ask the engineer for clarification.

Now make a layout sketch on graph paper as shown in Figure 20.60. The blocked-out areas next to the symbols represent intended component labeling. There is more than one correct way to lay out a schematic. Figure 20.61 shows the same schematic with an optional layout. The basic difference between this layout and the previous one is that the components attached to the top side of the active devices have been **folded down** as shown in Figure 20.62. The result of the folded-down form is a long, narrow schematic. This layout can be used to an advantage when the height of the schematic is fixed but the length can vary, as in foldout pages in instruction manuals. This form gives the advantage of providing a clear space above the active device for labeling or circuit notations.

### Labeling and Circuit Notations

There are two parts to the schematic layout—the symbols and the labeling. Without labeling, the symbols mean nothing more than the component they represent. The designating system has developed around a letter that indicates the type of component followed by a number that gives the sequence of the part in the circuit. For example, the first resistor in the

CORRECT	INCORRECT	CORRECT	INCORRECT

FIGURE 20.54 Schematic do's and don'ts. © Cengage Learning 2012

upper left of the schematic is designated R1. The next resistor to the right is R2 and so on across the schematic. The same holds true for capacitors—for example, C1, C2, and C3. Some of the other common component reference designators are transistor = Q, inductor = L, diode = D, jack = J, and

plug = P. On simple circuits, the number sequence flows from left to right, as shown in Figure 20.63. In schematics that are more complex, there can be two or more levels with each level flowing from left to right and top to bottom as shown in Figure 20.64.



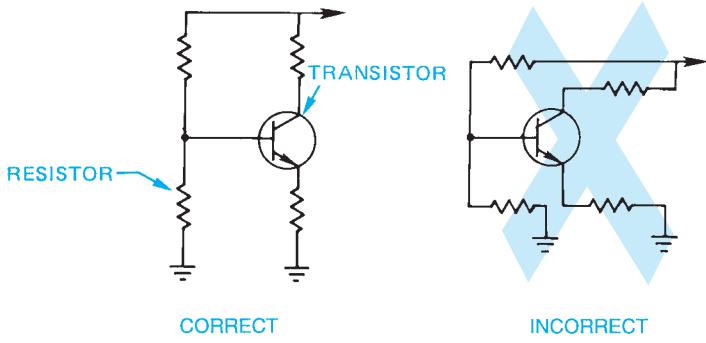


FIGURE 20.55 Resistors placed in relation to the active device.  
© Cengage Learning 2012

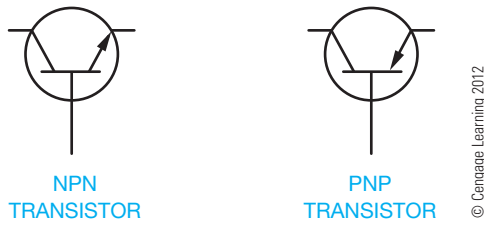


FIGURE 20.56 Changing the bias direction of a transistor.

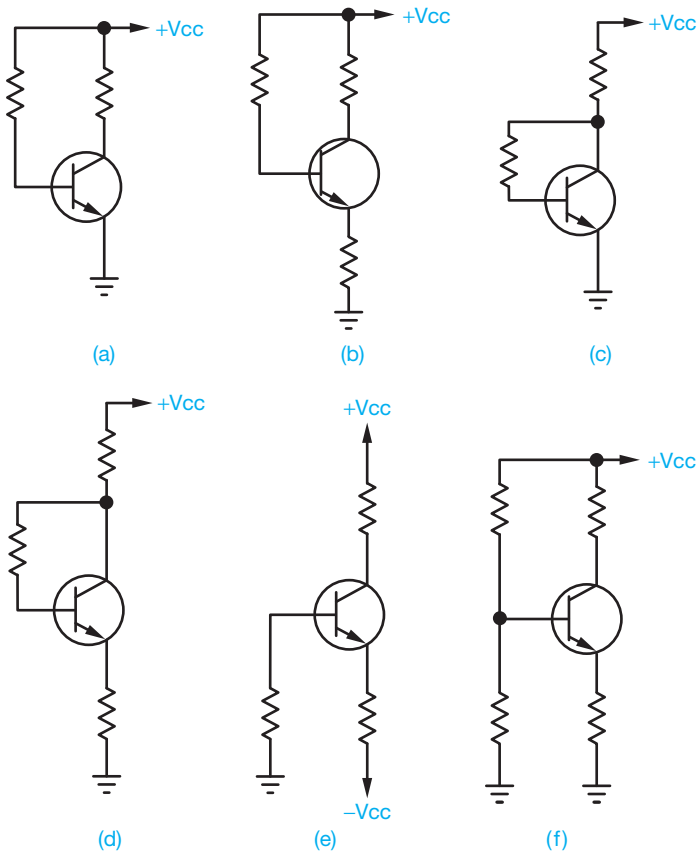


FIGURE 20.57 Common transistor bias circuit arrangements.

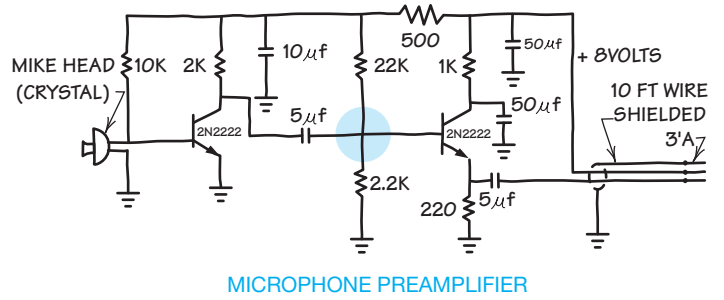


FIGURE 20.58 Engineer's rough sketch. © Cengage Learning 2012

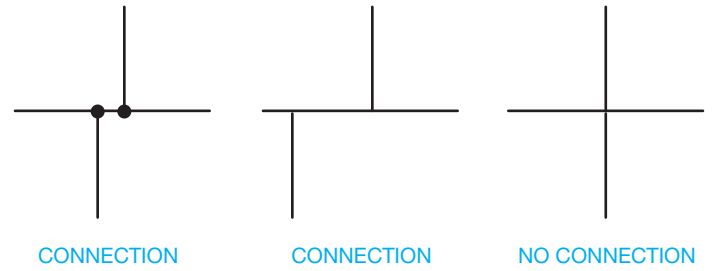


FIGURE 20.59 Standard connection and nonconnection details. © Cengage Learning 2012

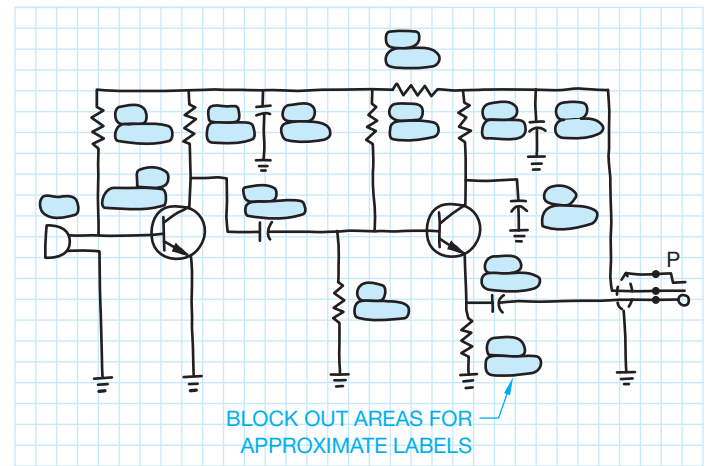


FIGURE 20.60 Schematic layout sketch. © Cengage Learning 2012

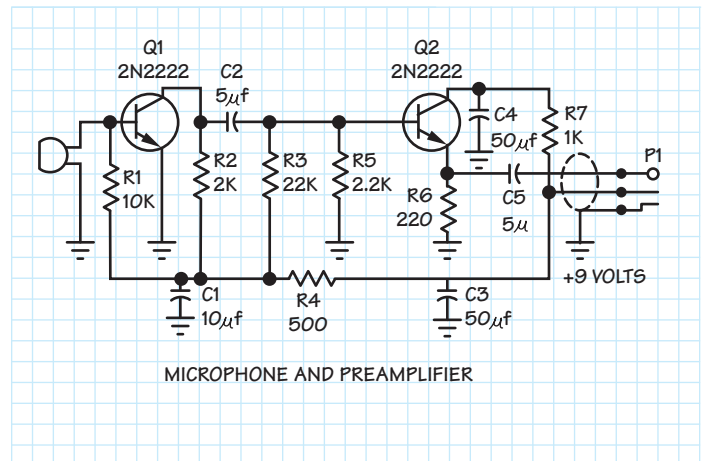


FIGURE 20.61 Optional layout sketch. © Cengage Learning 2012

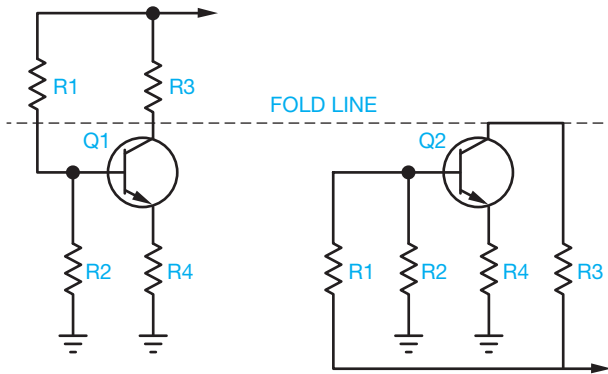


FIGURE 20.62 Folding down the schematic.

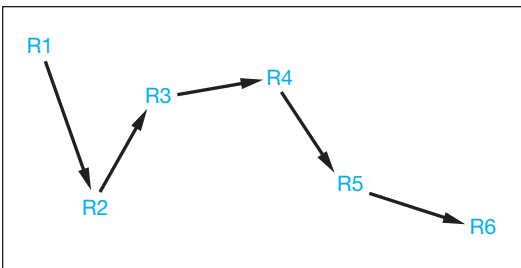


FIGURE 20.63 Left-to-right component numbering sequence.

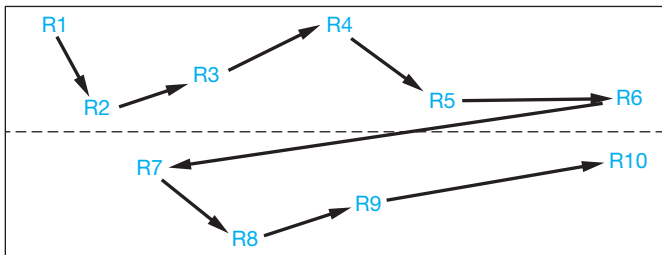


FIGURE 20.64 Component numbering sequence applied in layers.

Another method used in units that contain **subassemblies** or **modular construction** assigns the components a set of three- or four-digit numbers. Subassemblies are individual groups of components that make up a complete system. Modular construction is component groups made up of equal components. For example, Figure 20.65 shows the vertical sweep module containing numbers from 100 to 199, the horizontal sweep module containing numbers from 200 to 299, the 300 series numbers ranging from 300 to 399, the 400 series numbers ranging from 400 to 499, and the 500 series numbers ranging from 500 to 599. The sequence of number series in schematics may be scrambled, established based on physical layout, or arranged from left to right and top to bottom. This is also sometimes used for multiple-sheet schematics. Notice the page numbers labeled in Figure 20.65. A computer program that generates numbers from left to right and top to bottom usually does the **annotation** automatically. The term *annotation* refers to numbers and text.

300 SERIES PAGE 3		500 SERIES PAGE 5	400 SERIES PAGE 4
VERT SWEEP PAGE 1 C101 C102	HORIZ SWEEP PAGE 2 L201 C201		

FIGURE 20.65 Numbering components in groups.

### Units Used for Parts Values

Electronic component values run from extremely small values (0.000000000005) to extremely large values (2,500,000,000,000). In either case, numbers in this form take up too much space on the schematic. The numbers 1500 or 0.0003 are probably acceptable. A zero should precede the decimal point for values less than 1. Common practice is to move the decimal point in groups of three and then modify the numerical name to indicate the number of places the decimal point has been moved. For example, if you have a 2,200 ohm resistor, you can move the decimal point three places to the left, drop the zeros, and change the numerical name to **kilohms**, which means 1000 ohms. The result is the designation 2.2 kilohms. The word *kilohms* is abbreviated k, thus reducing the notation to 2.2 k for a savings of more drafting space. The word *ohms* can be omitted because all resistors are rated in ohms. The following terms are used to rate or size common components:

- Resistors = **ohms** = the unit of measurement of resistance. Symbol =  $\Omega$ . Typical ranges are 0.1 ohm to 10m ohm.
- Capacitor = **farad** = the unit of measurement of capacitance.
- **Capacitance** is the property of an electric circuit to oppose a change in voltage. Symbol = *f*. Typical range is 10 pf to 10,000  $\mu$ f.
- Inductor or coil = **henry** = the unit of measurement of inductance. **Inductance** is the property of a component in an electric circuit that opposes a change in current flow. Symbol = H. Typical range is 1 nH to 10 H.

The following chart shows the values achieved by moving decimal points in given numbers.

Number	Move Decimal	Add Prefix	Abbreviation
1,000,000,000,000	Left 12 places	1 tera	1 T
1,000,000,000	Left 9 places	1 giga	1 G
1,000,000	Left 6 places	1 mega	1 M
1,000	Left 3 places	1 kilo	1 k
1	No change	1	1
0.001	Right 3 places	1 milli	1 m
0.000001	Right 6 places	1 micro	1 $\mu$
0.000000001	Right 9 places	1 nano	1 n
0.000000000001	Right 12 places	1 pico	1 p

There are some inexact areas in the units used for parts values system. For example, there are no firm rules on which conversion

for 500,000 is best—0.5 M or 500 k. However, 500 k is normally preferred. The number 1200 can be left as is or reduced to 1.2 k.

### Military Identification Systems

Schematic diagrams drawn to meet military specifications provide a more detailed component identification system. For example, conventional part identification can be R304. In the military system, this part is labeled something like 14A2A4R304. This means that component R304 is located in subassembly 4 of subassembly 2A of assembly 14A. Military specifications are available that cover every element used in the design, construction, and packaging of electronic equipment.

### STANDARDS

**MIL-HDBK/MIL-STD** Some of the United States military defense handbook (MIL-HDBK) and military defense standard (MIL-STD) documents include MIL-HDBK-454A, *Standard General Requirements for Electronic Equipment*, and MIL-STD-681E, *Identification Coding and Application of Hook-up and Lead Wire*.

### Placement of Identification Numbers and Values

The placement of **identification numbers** is standard. The reference designator and **value numbers** are typically placed above horizontal components (see Figure 20.66). Other arrangements could cause confusion when components are not adequately spaced as shown in Figure 20.67.

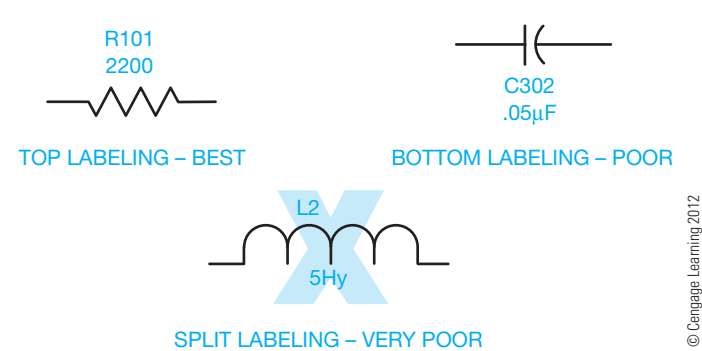


FIGURE 20.66 Horizontal component labeling.

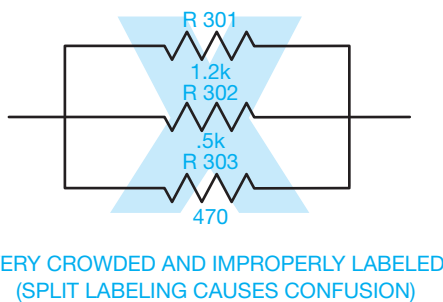


FIGURE 20.67 An overcrowded schematic using split labeling. Avoid the practice.

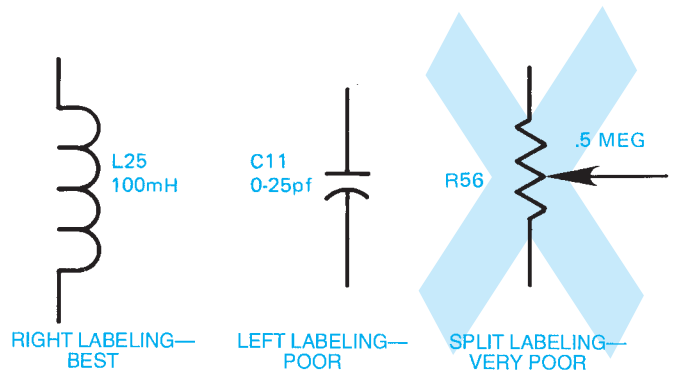


FIGURE 20.68 Vertical component labeling. © Cengage Learning 2012

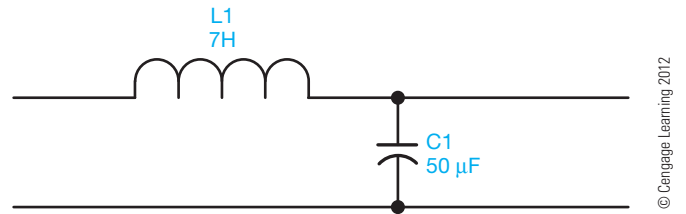


FIGURE 20.69 Preferred labeling at the top of horizontal components and to the right of vertical components.

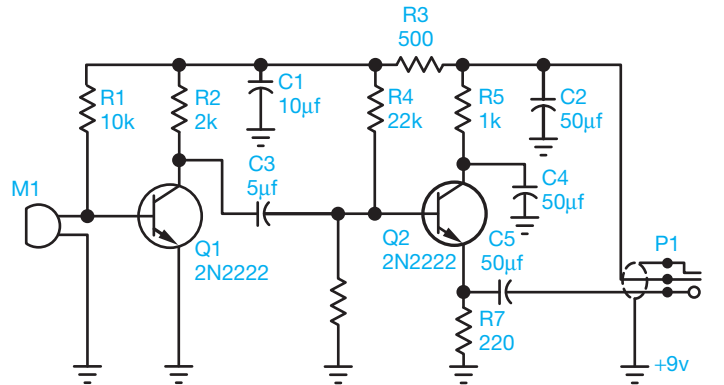


FIGURE 20.70 Final drawing of schematic used in layout sketches (Figures 20.57 through 20.59). © Cengage Learning 2012

For vertically drawn components, the reference designator and the value are commonly placed on the right side of the symbol (see Figure 20.68). The preferred technique in component labeling is placement of part identification at the top of all horizontal symbols and to the right of all vertical symbols, as shown in Figure 20.69. Figure 20.70 shows a final drawing of the schematic used in the sketching layout examples.

### Operational Amplifiers and Integrated Circuit Schematics

An **amplifier (AMP)** is a device that allows an input signal to control power and is capable of an output signal greater than the input signal. An **operational amplifier (OP AMP)** is

a high-gain amplifier created from an integrated circuit. An **integrated circuit (IC)** is an electronic circuit that has been fabricated with extremely small components as an inseparable assembly known as a **chip**. You can become involved with integrated circuit schematics by drawing the schematic of the internal circuitry involved or by drawing the schematic for a system in which integrated circuits or operational amplifiers are used.

### Internal Integrated Circuit Schematics

Figure 20.71 shows the internal circuitry of an integrated circuit. The only exception is that the IC diagram does not circle the transistor symbols. Dashed lines in the form of a box also sometimes enclose the diagram. This box represents the package within which the IC is contained. **Pin numbers** show and label points, which are external connectors for attachment to other circuitry. This usually means that all of the components shown in the schematic are made up of one piece of semiconductor material, thus the definition of integrated circuit—all of the components of the circuit have been put together on one small piece of material. The schematic for an IC can be very simple or so complex that it contains several million components and hundreds of pins.

### IC Symbols and Logic Circuits

In **logic circuits**, which are computer-oriented circuits, the schematics become a cross between a flow diagram and a schematic diagram. The internal components of an IC are self-contained for a specific function and may not be altered. Therefore, symbols are used that identify the IC. The shape of the symbol tells the function of the device. The numbers next to the input and output lines or pins tell how to connect the IC to make it work. Figure 20.72 shows the basic format of IC

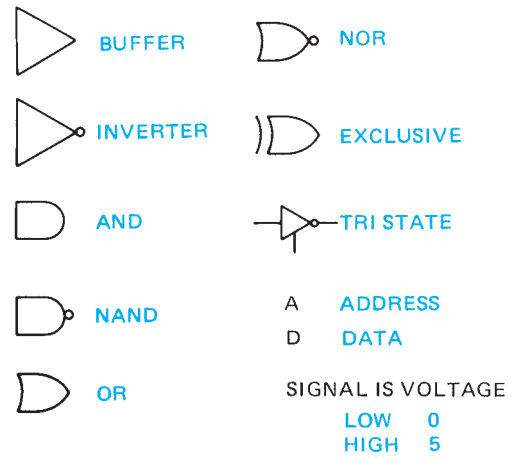


FIGURE 20.72 The basic format of IC symbols.



FIGURE 20.73 The IC symbol of the internal IC schematic shown in Figure 20.71. © Cengage Learning 2012

symbols. Figure 20.73 shows the IC symbol that represents the internal IC shown in Figure 20.71. This symbol is called a **NAND gate**. The gate is the part of the system that makes the electronic circuit operate and permits an output only when a predetermined set of input conditions is met. The code NAND is the predetermined function of the gates. There are also AND, OR, and NOR functions. The basic functions relate to a condition or pattern of conditions whereby an electrical pulse can be received at one pin when the input at another pin or pins is triggered at specific times.

The precise operation of each logic function is required knowledge for electronic technicians and design drafters, but it is premature for drafting fundamentals and beyond the scope of this textbook. Your concern at this time is to prepare a well-balanced, accurate drawing from engineering sketches. Notice how the IC schematic diagram shown in Figure 20.74 compares to previous schematics. The difference is in the IC symbols. Although

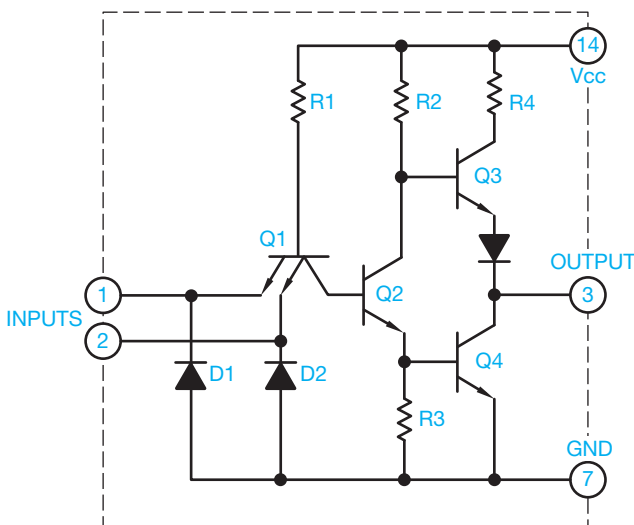


FIGURE 20.71 The internal components of a logic integrated circuit.

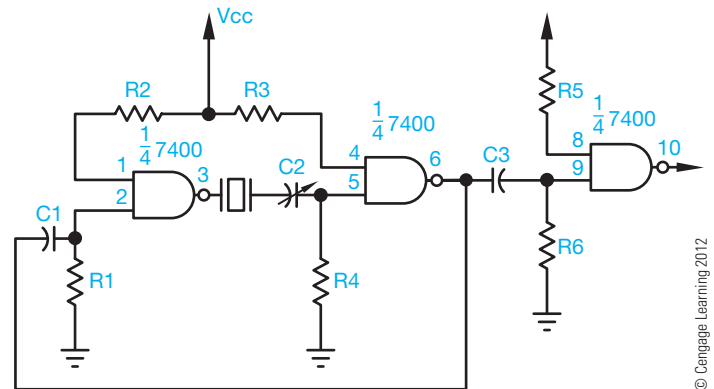


FIGURE 20.74 A schematic diagram with an IC included.

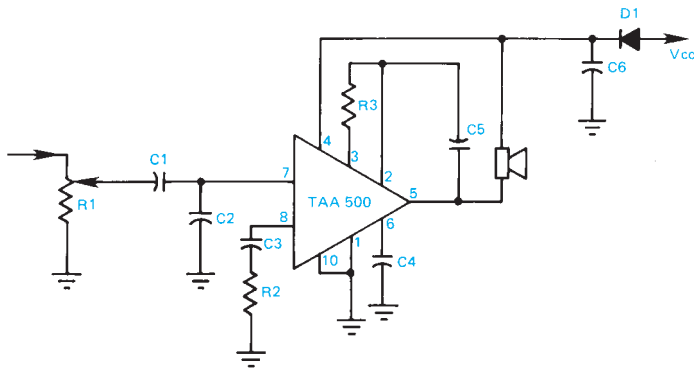


FIGURE 20.75 Amplifier IC. © Cengage Learning 2012

the integrated circuits are complex in nature, the drafting task becomes easier when ICs are used. For example, the IC labeled TAA-500 in Figure 20.75 is an operational amplifier that contains 11 transistors, five diodes, 13 resistors, and one capacitor.

Logic diagrams are a type of schematic that show the logical sequence of events in an electrical or electronic system. Figure 20.76 shows basic electronic logic symbols and their functions. Figure 20.77 shows a portion of an electronic

TITLE	SYMBOL	
AND		ALL INPUTS MUST BE PRESENT FOR OUTPUT.
OR		ANY INPUT WILL ALLOW OUTPUT.
NOT		AN INPUT WILL RESULT IN NO OUTPUT.
TIME DELAY		AN INPUT WILL ALLOW AN OUTPUT AFTER A TIME DELAY.
ON OFF		INPUT "A" WILL ALLOW AN OUTPUT EXCEPT WHEN THERE IS AN INPUT AT "B."

FIGURE 20.76 Basic electronic logic symbols are currently being used, but are becoming obsolete. © Cengage Learning 2012

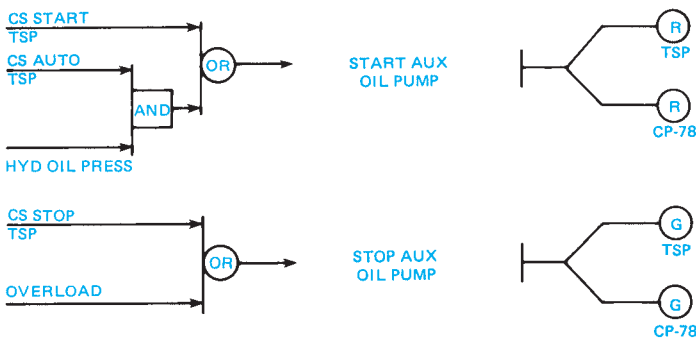


FIGURE 20.77 Part of an electronic logic diagram. © Cengage Learning 2012

logic diagram. These symbols are currently used but may become obsolete.

### Large-Scale Integration

The next generation beyond the specific symbols, such as the gates, came about because of the rapid advancement of the electronic industry's ability to put more and more circuits on a single small IC chip. Many calculators contain only one IC with hundreds of gates. The trend in drawing schematics for this large-scale integration (LSI) is to show the chip as a box. This type of schematic becomes like a block diagram with the name or function identified within the rectangle for each LSI. The LSI pin terminals are shown connected to the rest of the schematic. Figure 20.78 shows an LSI schematic diagram. Keep in mind that each LSI block in the schematic may contain hundreds or thousands of components.

### Symbol Sizes

The actual size of symbols can vary slightly from one company or CADD software to another. The uniformity of symbols within a drawing is important. Figure 20.79 shows the recommended sizes of commonly used electronics symbols based on the drawing text height.

## PRINTED CIRCUIT TECHNOLOGY

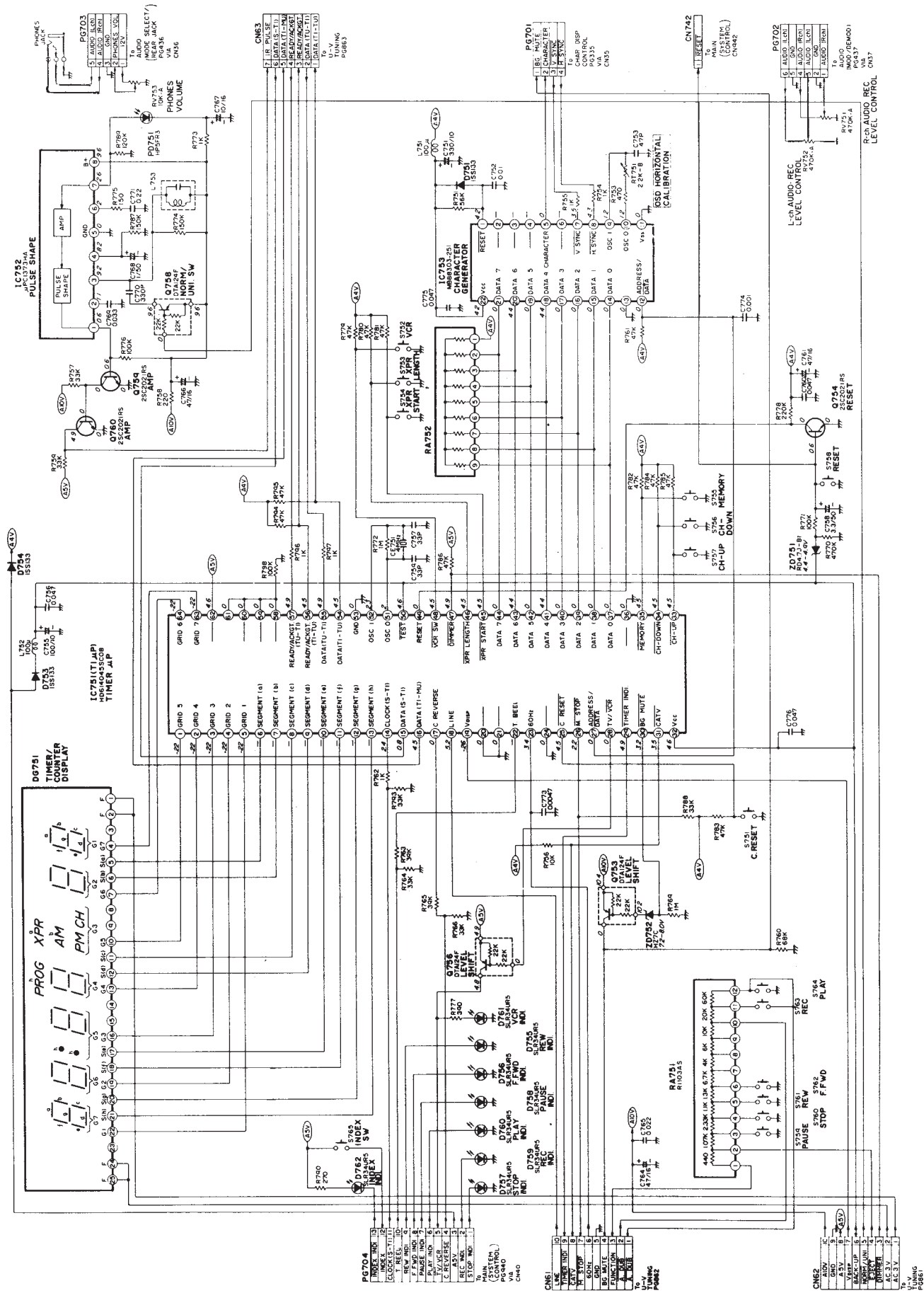
Schematic diagrams use symbols and lines to represent circuit paths or connections to show the location of electronic components. In the production of the actual electronic product, the symbols shown on the schematic become electronic devices and the lines become wires that connect the devices. At one time, wires were soldered to component terminals and used as the circuit path between components. Today, wires are used as the connection cables that provide the source of current between pieces of electronic equipment. As electronic equipment designs have become increasingly smaller, the internal connection between electronic devices must also take up less space, be easier to install, and be extremely accurate. Printed circuit technology is the answer to these needs.

### Schematic and Printed Circuit-Board Accuracy

Accuracy and close attention to detail in the preparation of the schematic and printed circuit board are essential. Everything depends on the accuracy of these two items. The schematic and the printed circuit board cannot have a single mistake, because any mistake affects the master artwork, the drilling drawing, and the assembly and bill of materials.

### Printed Circuit Design and Layout

Printed circuits (PC) form the interconnection between electronic devices. The base materials for circuit boards are special paper, plastic, glass, or Teflon. The quality of the printed circuit



**FIGURE 20.78** A large-scale integration (LSI) schematic. Reproduced by permission of RCA Consumer Electronics

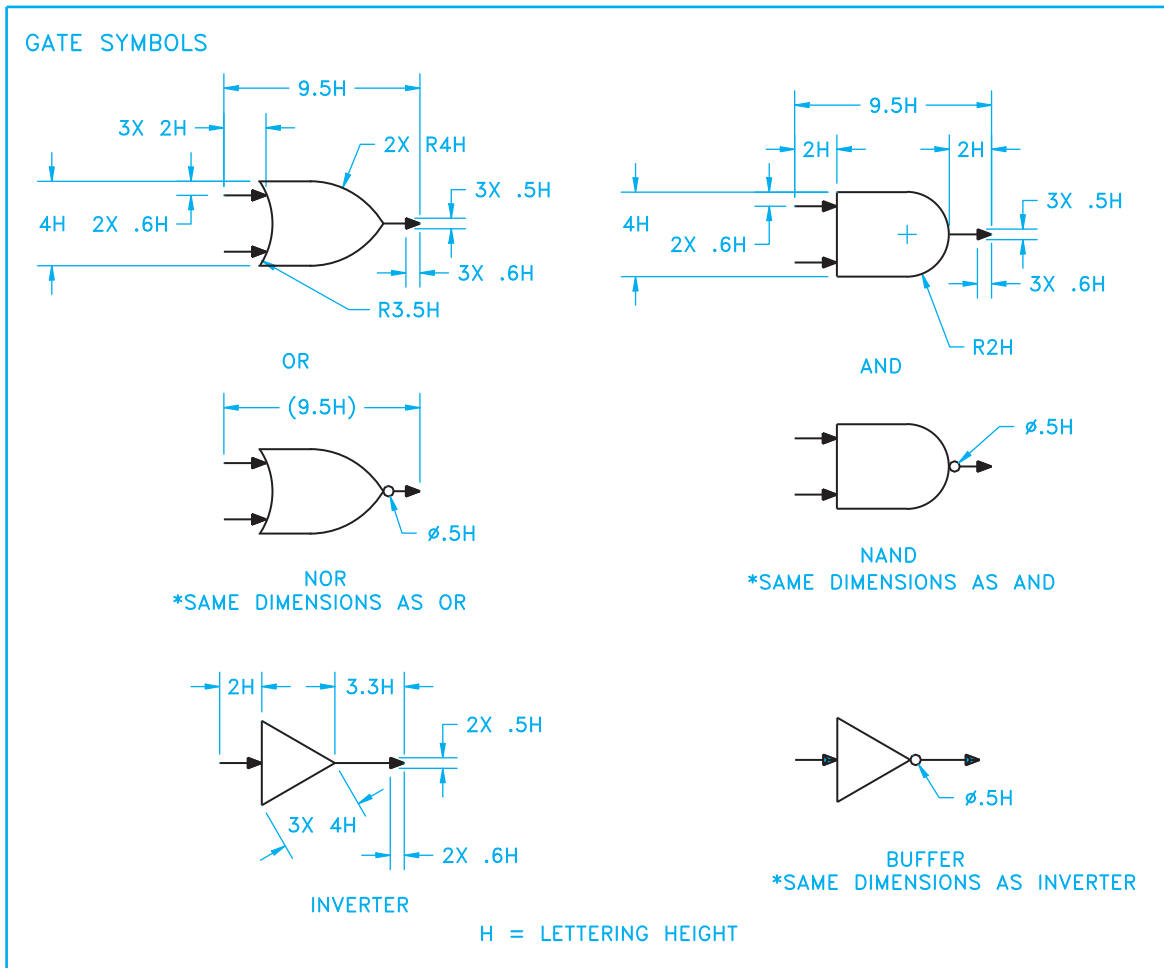
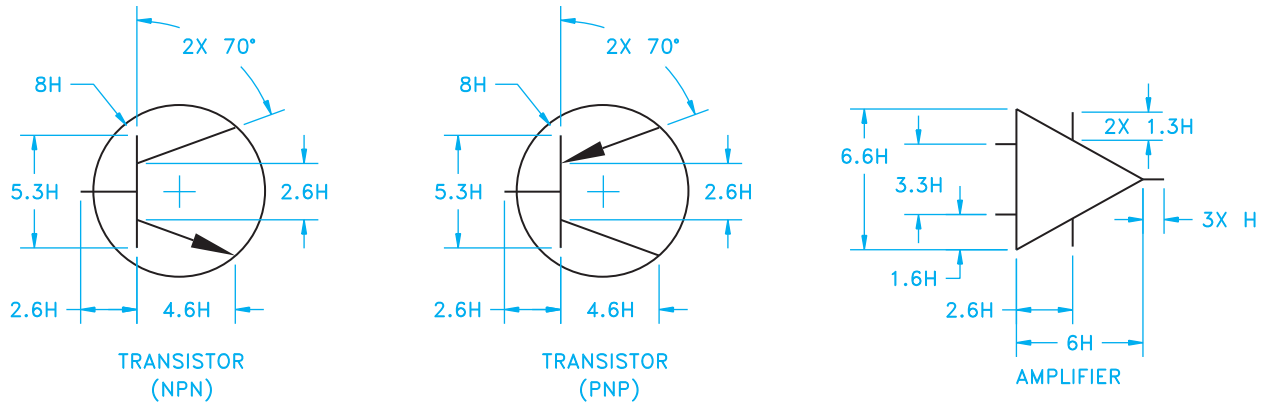


FIGURE 20.79 Recommended sizes of commonly used electronics symbols based on the drawing text height.

board (PCB) begins with the quality of the base material. A PCB is a flat plate or base of insulating material containing a pattern of conducting material that becomes an electrical circuit when components are attached. Depending on the complexity of the electronics, printed circuits are prepared on one side or both sides of the board. In many applications, there are multiple boards or layers for one piece of electronic equipment.

The printed circuits consist of pads and conductor traces that are made of thin conductive material such as copper on a

base sheet or board. The pads, also known as lands, are the circuit termination locations where the electronic devices attach. The pad normally has a location where a hole is to be drilled in the circuit board for mounting the device. Pads can be placed individually or in patterns, depending on the connection characteristics of the device (see Figure 20.80). Conductor traces, also known as conductor lines, connect the pads to complete the circuit design. Figure 20.81 shows design characteristics of conductors. The size depends on the amount of current, the

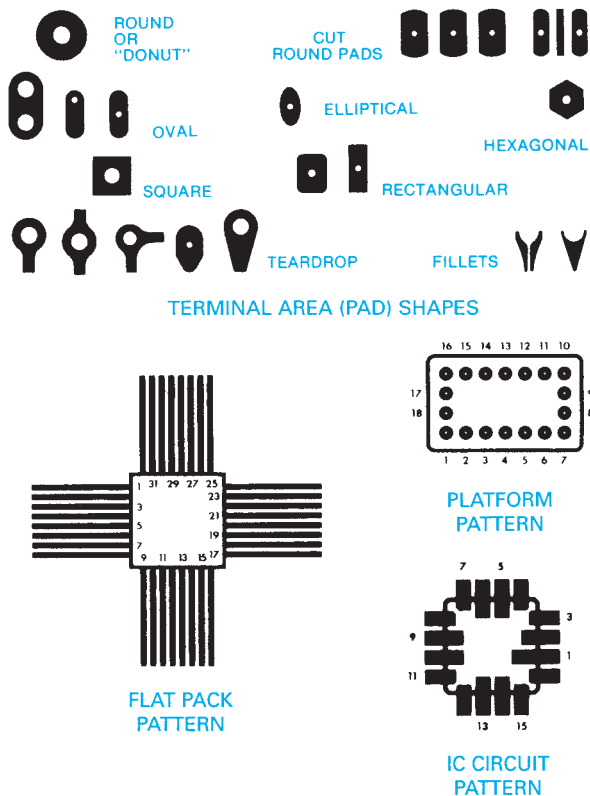


FIGURE 20.80 Mounting pads.

temperature, and the type of board specified. Conductors are .008 in. (0.2 mm) wide with a .007 in. (0.18 mm) space for many applications, but they can be designed for applications with a width of .50 in. (12.7 mm) or more for large current-carrying requirements. Factors that influence conductor spacing include product requirements and current specifications. For general uses, conductor spacing should be .007 in. (0.18 mm) minimum.

### Printed Circuit-Board Artwork

The **printed circuit-board artwork** is an accurate, scaled, un-dimensioned drawing used to produce the master pattern from which the actual board is manufactured. The artwork should be prepared from a design layout at an enlarged scale on polyester film using CADD. In addition to all electrical circuitry, the board should contain board edge identification marks; registration, datum, and indexing marks; photo reduction dimensions; scale designation; an identification number; and a revision number. Letters to be etched on the board should be .62 in. (1.57 mm) in height minimum and .015 in. (0.38 mm) in thickness minimum.

### Master Pattern Artwork

The **master pattern** is a one-to-one scale circuit pattern that is used to produce a printed circuit board. The master pattern

RECOMMENDED	NOT RECOMMENDED
<p>AVOID SHARP EXTERNAL ANGLES WHICH CAN CAUSE FOIL DELAMINATION.</p>	
<p>AVOID ACUTE INTERNAL ANGLES.</p>	
<p>ALWAYS USE THE SHORTEST PRACTICAL CIRCUIT ROUTING.</p>	
<p>MAINTAIN EQUAL SPACING WHERE CONDUCTORS PASS BETWEEN TERMINAL AREAS.</p>	
<p>AVOID LARGE MULTIPLE HOLE TERMINAL AREAS, WHICH MAY CAUSE THERMAL SOLDERING PROBLEMS AND NON-SYMMETRICAL SOLDER FILLETS.</p>	
<p>MAINTAIN UNIFORM PATTERN AROUND HOLE TO PRODUCE SYMMETRICAL SOLDER FILLETS.</p>	
<p>AVOID USING CONDUCTORS THE SAME SIZE AS TERMINALS, WHICH WILL CAUSE SOLDER TO FLOW AWAY FROM TERMINAL.</p>	
<p>PLATING BAR SHOULD EXTEND OUT FROM AND BEYOND BOARD EDGE TO FACILITATE FABRICATION.</p>	

FIGURE 20.81 Artwork pattern configuration, conductor traces, and taping techniques. Courtesy Bishops Graphics, Inc.

artwork is normally prepared at an enlarged scale so that when it is reduced to a 1:1 ratio, its quality is enhanced.

### Grid System

The use of a grid system is essential in laying out and preparing the master pattern artwork. The grid system aids in the placement of pads and conductor traces. A **grid** is a network of equally spaced parallel lines running vertically and horizontally



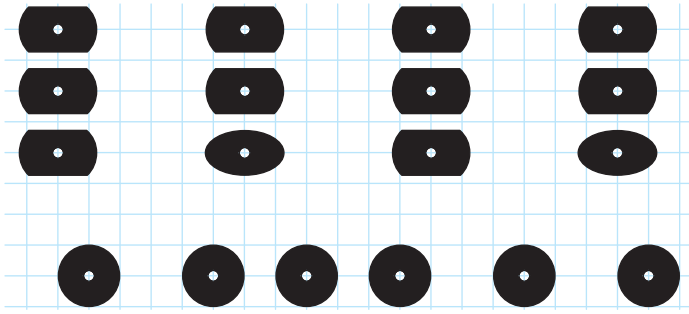


FIGURE 20.82 Grid system. Courtesy Bishops Graphics, Inc.

on a glass or polyester film sheet, as shown in Figure 20.82. Standard spacing is .100 in. (2.54 mm), .050 in. (1.27 mm), or .025 in. (0.635 mm).

**STANDARDS**

ASME The ASME Y14.31 standard, *Undimensioned Drawings*, establishes the requirements for undimensioned drawings, which graphically define items with true geometry views and mostly without the use of dimensions. Chapter 19, *Precision Sheet Metal Drafting*, of this textbook describes undimensioned drawing applications.

IEC The IEC standards specify master pattern grid increments of 0.5 mm and 0.1 mm.

IPC The Association Connecting Electronics Industries (IPC) document IPC 2221A, *Generic Standard on Printed Circuit Board Design*, provides information on the generic requirements for organic printed board design. IPC 2221A specifies a master pattern grid spacing of any multiple of .005 in. (0.127 mm). For more information or to order standards, go to the IPC Web site at [www.ipc.org](http://www.ipc.org).

**Printed Circuit Scale**

Prepare the printed circuit-board layout at an enlarged scale of 2:1 or 4:1 to minimize possible drafting errors or slight flaws when the layout is reduced to actual size. The accuracy of the PC layout is also critical. Sometimes it is necessary to prepare the PC layout at a 100:1 scale to ensure clarity and accuracy.

**Board Size and Number of Layers**

Printed circuit boards can be designed in three basic configurations: single layer, multilayer, and multilayer sandwich. **Single-layer boards** contain all printed wiring on one side with the components on the opposite side. **Multilayer boards** have printed circuits on both sides with most of the components on one side and the circuitry on the other. **Multilayer sandwich boards** consist of many thin boards laminated together, with the components on one or both sides of the external layers. As boards increase in complexity, they also cost more. However, the cost of a single multilayer board can be less than several single-layer boards for the same system.

The circuit board should be just large enough to contain the components and interconnections and remain economical to manufacture. One way to estimate the board size is to randomly place scaled component cutouts, allowing enough space for interconnections and extra space for IC interconnections.

**Solder Masks**

**Wave solder** has become a common method of attaching components to printed circuit boards. A wave of molten solder is passed over the noncomponent side of the board, making all solder connections. A polymer coating, called a **solder mask** or **solder resist mask**, is applied to the board, covering all conductors except pads, connector lands, and test points. Solder masks are used to prevent the bridging of solder between pads or conductor traces, to cut down on the amount of solder used, and to reduce the weight of the board.

**Conductor Width and Spacing**

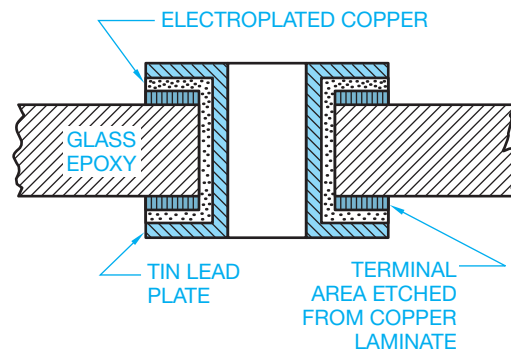
Careful consideration must be given to conductor trace width and spacing during printed circuit design. **Width** and **spacing** that are too small can cause service problems in the circuitry. Width and spacing that are too great waste space and increase costs. Verify minimum width and spacing requirements with product and company specifications. Standard charts and specifications are available, but generally conductor widths of .050 in. (1.27 mm) or .062 in. (1.57 mm) and minimum spacing between conductors from .031 in. (0.79 mm) to .050 in. (1.27 mm) are recommended for low-voltage applications.

**Component Terminal Holes**

A printed circuit board should have a separate mounting hole for each component lead or **terminal**. A terminal is a connection point or device. Unsupported holes contain no conductive material. Use the formula to determine the diameter of unsupported holes:

$$\begin{aligned} &\text{Maximum lead diameter} + \text{Minimum drill tolerance} \\ &= \text{Minimum hole diameter} \end{aligned}$$

**Plated-through holes** have conductive material plated on the inside wall to form a conductive connection between layers of the circuit board, as shown in Figure 20.83. Plated-through holes are drilled before plating. Specify the general note: ALL



Courtesy Bishops Graphics, Inc.

FIGURE 20.83 Cross section of plated-through hole.

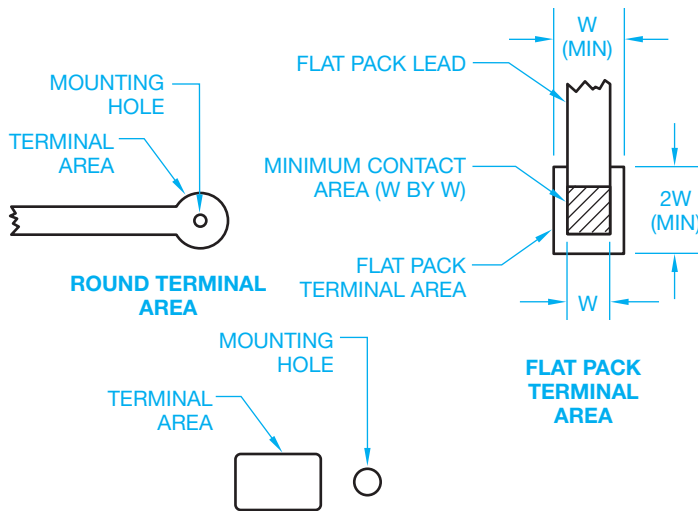


FIGURE 20.84 Terminal areas. Courtesy Bishops Graphics, Inc.

**HOLES TO BE PLATED THROUGH.** Usually, plating thickness is specified as a minimum with an accepted tolerance of  $-0 + 100\%$ . For plated holes, the minimum diameter should be greater than the minimum lead size plus .028 in. (0.71 mm). A second drilling process is required if the predrilled holes do not take into account the plating thickness. Drilling twice adds cost to the board. The number of different hole sizes should be kept to a minimum to help save manufacturing costs. Plating is specified in ounces (oz) of copper. The base is typically 1/2 oz (14.2 grams) plating, but it can be up to 1–2 oz (28.35–56.7 grams). In addition, .0014" (0.035 mm) thick is specified as 1 oz (28.35 grams) of copper, which equals 1 oz per square foot.

### Terminal Pads

A printed circuit board should have a separate terminal pad for each component lead or wire attachment. Terminal pads vary with designer preference and component characteristics (see Figures 20.80 and 20.84). The **minimum required annular ring**

is the smallest part of the circular strip of conductive material surrounding a mounting hole that meets design requirements.

### STANDARDS

IPC The document IPC 2221A, *Generic Standard on Printed Circuit Board Design*, specifies .015 in. (0.38 mm) minimum for unsupported holes, .005 in. (0.13 mm) minimum for plated-through holes on external layers, and .002 in. (0.05 mm) for internal layers of multilayer sandwich boards.

### Ground Planes

A **ground plane** is a continuous conductive area used as a common reference point for circuit returns, signal potentials, shielding, or heat sinks. Ground plane patterns should be broken up so the conductive area is equal to about half of the nonconductive area (see Figure 20.85). Clearance should be provided between terminal pads and the ground plane, as shown in Figure 20.86.

### Printed Circuit-Board Layout

Before starting a printed circuit-board layout, you should have a schematic or logic diagram, a parts list, design specifications, component sizes, lead-and-trace pattern and spacing, hole and terminal sizes, grid system, scale, board size, and number of layers, and you should know the manufacturing processes to be used.

### Silk Screen Artwork

The circuit-board artwork can have a separate sheet called **silk screen artwork** containing component outlines and orientation symbols. The silk screen artwork pattern is printed on the component side of the board after etching and plating. The reference designations should be placed so they are visible after component assembly. The component outlines should be located in the same position that the actual components occupy

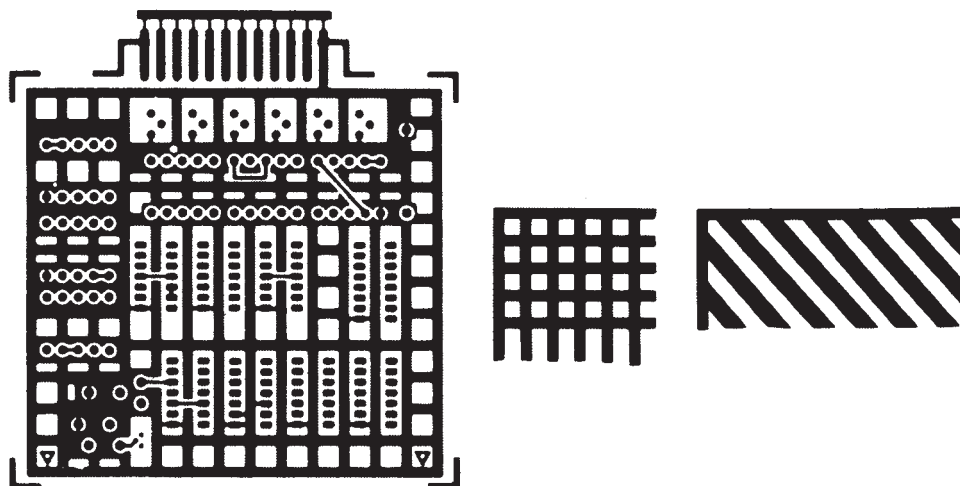


FIGURE 20.85 Ground planes.

Courtesy Bishops Graphics, Inc.

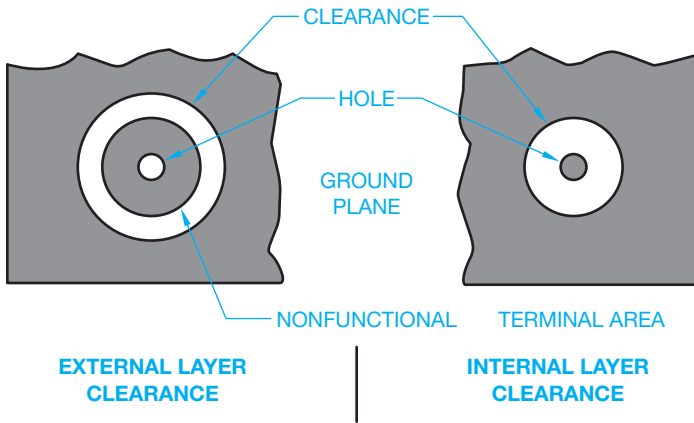


FIGURE 20.86 Layer clearance at ground planes. Courtesy Bishops Graphics, Inc.

after assembly. The silk screen artwork should include registration marks that align with the pattern (see Figure 20.87).

### Drilling Drawings

**Drilling drawings** are prepared after the master layout is complete. The drilling drawing provides size and location dimensions for component and chassis mounting holes and the final dimensions for trimming the board. Drilling drawings are often set up using datum arrowless tabular dimensioning in accordance with computer numerical control (CNC) manufacturing methods (see

Figure 20.88). Refer to the previous discussion on hole sizes, and Chapter 10 for more information on dimensioning practices.

### Assembly Drawings

The printed circuit-board **assembly drawing** is a complete engineering drawing, including components, assembly and fastening or soldering specifications, and a parts list or bill of materials. The parts list should include the part number, item identification keyed to the assembly, quantity of each part, electronics designations for components, and CAGE code or design activity identification (DAI), if required by contract (see Figure 20.89).

### Printed Circuit Preparation

There are several methods used to prepare the final printed circuit board from a printed circuit layout. The two fundamental methods are the additive and the etching processes.

### Additive Process

The **additive process** takes place on a board that is covered with a chemically etched material that will accept copper. The PCB layout design image is then transferred to the board using a silk screen or photo printing process. Copper conductor is then deposited on the image using **electrolysis**. Electrolysis is the depositing of a metal on another material through the action of an electric current. A **solder resist mask** is then applied

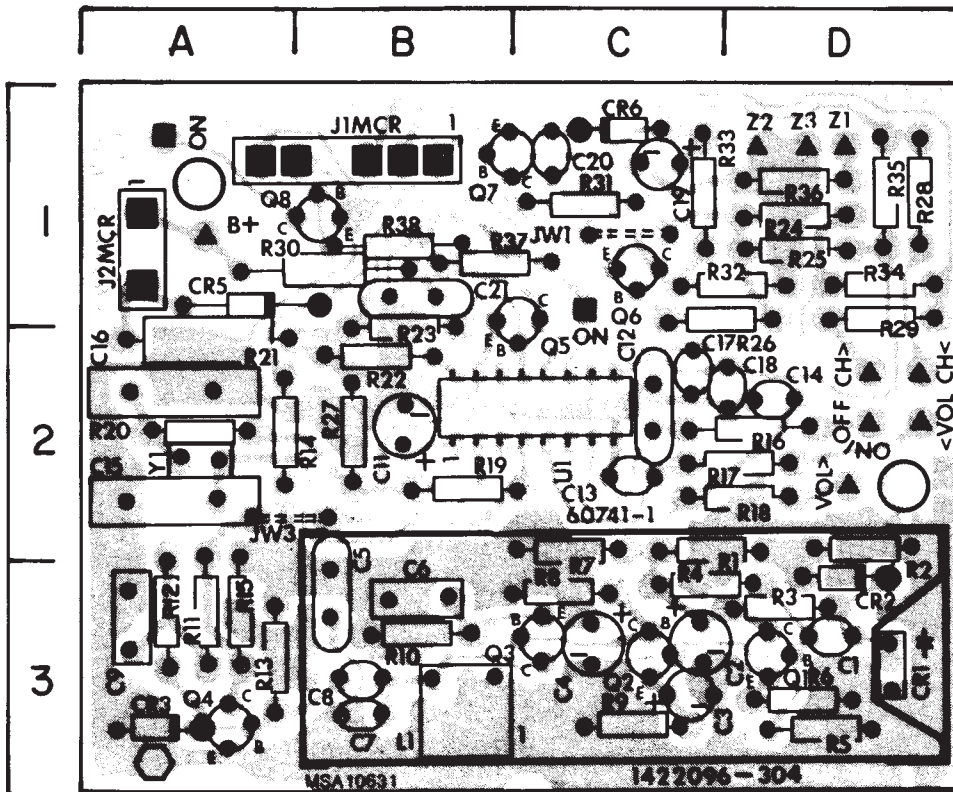


FIGURE 20.87 Silk screen artwork.

Courtesy RCA Consumer Electronics

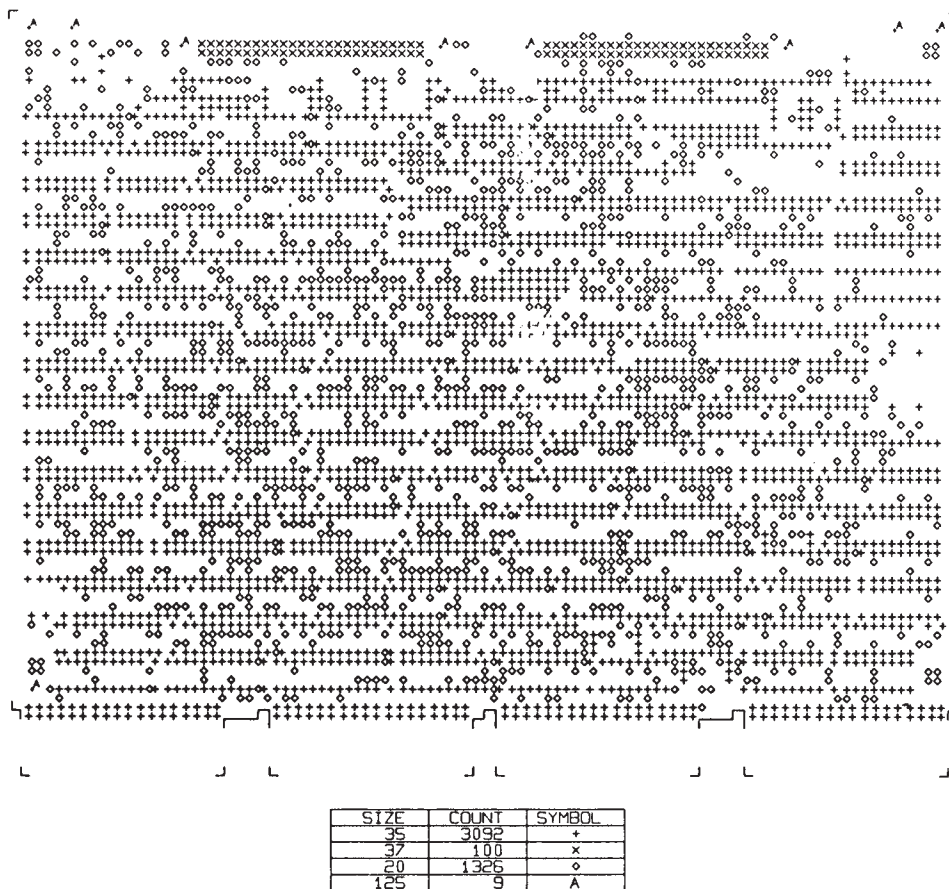


FIGURE 20.88 Drilling drawing.

Courtesy Floating Point Systems, Inc.

to the copper deposit. This process prevents solder from bridging between closely spaced conductors when components are added to the printed circuit board. The board is then coated with a lacquer to protect the surface from corrosion.

### Etched Process

A copper-covered base is used in the **etched process**, although other conductive material can be used. The etched process results in the circuits on the PCB. The printed circuit layout is normally prepared at 2:1 or 4:1 scale and then photographically reduced to a photo negative at full scale. The copper-covered base is cleaned and treated with a light-sensitive emulsion. The base is then exposed to light through the negative. During this process, the emulsion hardens and an acid resist is formed at the printed circuit areas. The board is then placed in a chemical solution that etches away the copper coating in areas that are not protected by the acid resist. The board is then rinsed to stop the etching process, and a protective coating is added. The resulting printed circuit is ready for components to be added.

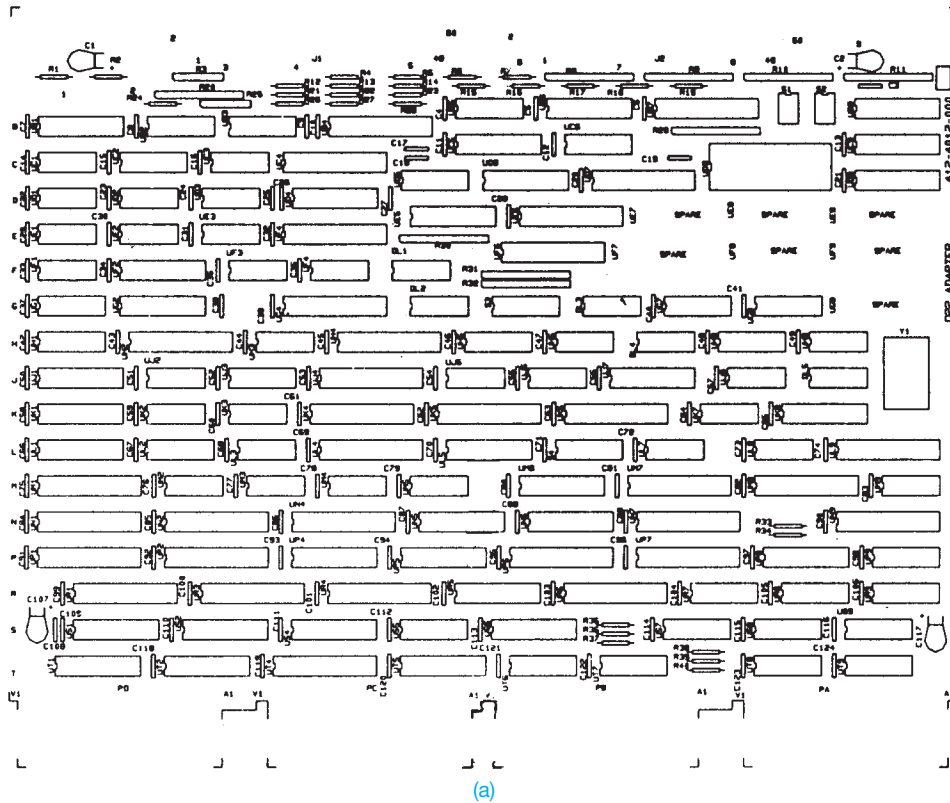
### Surface-Mount Technology (SMT)

Surface-mounted devices (SMD) allow more electronic components into smaller places. Surface-mounted devices commonly

take up to less than one-third the space of feed-through printed circuits. Conventional printed circuit-board connectors require plated-through holes for each pin or connection point. Surface-mounted devices save the area and are especially useful when designing very complex boards. The only drilled holes that are required are for chassis mounting or feed-through between layers.

In surface-mount technology, a **solder paste** replaces the traditional component lead-through to hold or glue the components in place on the surface of the printed circuit board. A solder paste template is made that allows for the placement of the paste at required areas. Then the components are automatically or manually placed into the solder paste, although most companies use robotic fabrication. A baking process allows the solder to liquefy; with solidification, the components remain soldered to the printed circuit. Some solderless connections have also been designed for surface-mounted devices.

Surface-mount technology is responsible for new types of electrical components and materials used in electronic circuits, such as leadless plastic and ceramic IC chip housings. However, there are some problems with surface-mounted devices. For example, some are so dense that solder connections often become difficult, and testing electrical circuits becomes a problem because testing equipment may have difficulty connecting to very small fine-pitch parts. In most cases,



(a)

A20112221 DATA DATE 86-102 FLOATING POINT SYSTEMS \*\*COMPANY CONFIDENTIAL\*\* 05/23/95 PAGE 1

REQUESTOR ID ECD SINGLE LEVEL BILL OF MATERIAL 612-4022-000 PAGE 1

OPTIONS- EFFECTIVITY 2 DATE ITEM TYPE 1

PARENT ITEM NUMBER	ITEM DESCRIPTION	ITM TYP	ITM CLS	ITEM STAT	QTY	UM	DEM	ISS	OSGN	DWG	ENGR	MFG
612-4022-000	ECB ASSY,(022),P1,64K PS	1	G	1	0	EA	1	1			REV 01 ECD V112 EFFECT 85-090	01 V112 86-090

FIND NO	COMPONENT ITEM NUMBER	ITEM DESCRIPTION	ITM QTY	ST	T	COMP QTY	PCT	L/T	WORK	DEM	ISS	REV	ECO	DATE
001	512-3022-000	SCHEM ECB (022),P1,64K PS	1	2		0	EA	4	00 00 000	2	1	IN 85-090	1	V112 86-086
002	528-0022-000	CAM DATA,ECB,(022),P1,64K PS	1	2		0	EA	4	00 00 000	2	1	IN 85-090	1	V112 86-086
003	529-0022-000	DR TAPE,ED3,ASSM30 B0,TES I FXTR,(022)P1,64K PS	1	2		0	EA	4	00 00 000	2	1	IN 86-090	1	V112 86-086
004	412-4022-000	EC3 (022),P1,64K PS	1	1		1	EA	1	00 00 000	1	1	IN 85-090	1	V112 85-086

(b)

Courtesy Floating Point Systems, Inc.

FIGURE 20.89 (a) Assembly drawing. (b) Partial computerized parts list.

surface-mounted boards are replaced, rather than serviced, when maintenance is required.

### PICTORIAL DRAWINGS

Three-dimensional drawings are frequently made to show pictorial representations of products for display in vendors' catalogs or instruction manuals. Pictorial assembly drawings are often used to show the physical arrangement of components to help factory workers properly place components during assembly. Pictorial assembly drawings are also helpful for maintenance as they provide a realistic representation of the product.

One of the most effective uses of photodrafting is found in the electronics field. In photodrafting, a photo is taken of a complete assembly or product, and drafting is used to label individual components. A common method of pictorial representation is the exploded technical illustration often used for parts identification and location, as shown in Figure 20.90.

Another type of pictorial diagram, known as a semipictorial wiring diagram, uses two-dimensional images of components in a diagram form for use in electrical or electronic applications. The idea is to show components as features that are recognizable by laypersons. This type of pictorial schematic is commonly used in automobile operations manuals, as shown in Figure 20.91.

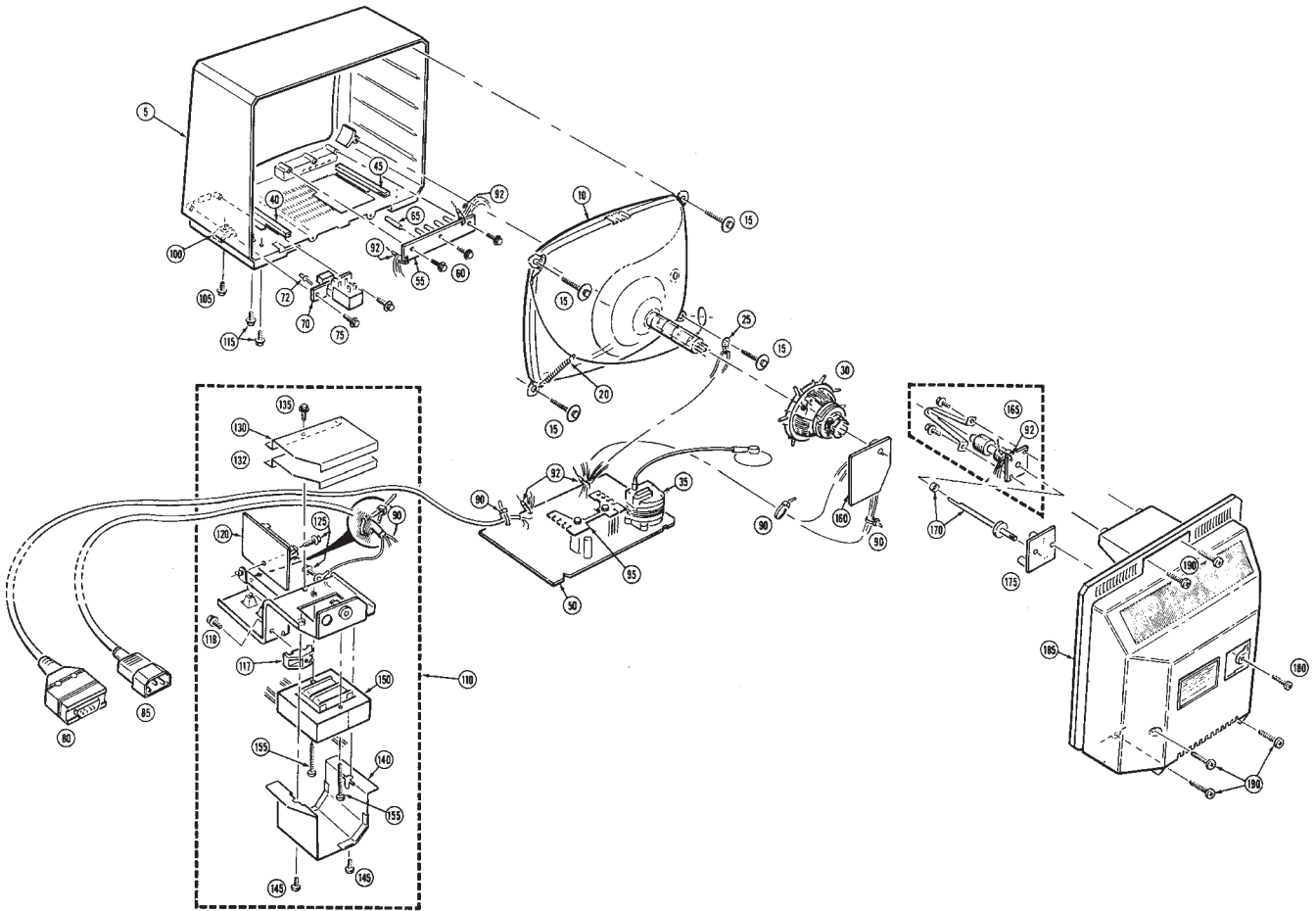


FIGURE 20.90 Parts pictorial, exploded technical illustration.

Reprinted by permission of HEATH COMPANY



Text not available due to copyright restrictions

Courtesy Chrysler Corporation

## DOWNLOAD BUILDING PRODUCT MODELS, DRAWINGS, AND SPECIFICATIONS

The Autodesk® Seek ([seek.autodesk.com](http://seek.autodesk.com)) free Web service allows architects, engineers, and other design professionals to discover, preview, and download branded and generic building information modeling (BIM) files, models, drawings, and product specifications directly into active design sessions in Autodesk Revit® or AutoCAD® software. For building product manufacturers, Autodesk Seek offers a unique way to connect with the professional designers ultimately responsible for specifying and recommending their products for purchase. Autodesk Seek provides the following features:

- **Manufacturer-supplied product information:** Access building information models, drawings, and product specifications for more than 35,000 commercial and residential building products from nearly 1000 manufacturers.
- **Powerful parametric search technology:** Search by key attributes, including dimensions, materials, performance, sustainability, or manufacturer name using industry-standard classifications.
- **Preview and explore models before downloading:** View, rotate, zoom, and slice product models and

then download the accurate files directly into your design session. For Revit models, preview the family parameters and associated type catalogs before download.

- **Multiple formats:** Select the formats that work for you, such as Revit, DWG™, DGN, and SKP files; Microsoft® Word documents; three-part specifications; and PDFs.
- **Share designs:** You can share designs with peers by uploading them directly from your AutoCAD files to the Autodesk Seek User Uploads. Easily access the Share with Autodesk Seek button from the Output panel of the ribbon tab. You can choose to share the current drawing or select a block definition within the drawing. Thumbnails, title, and metadata are automatically extracted and indexed. Shared designs can be searched and downloaded by anyone.

When using Autodesk Seek, your default browser launches and displays search results. Figure 20.92 shows the browser open with a sample of electrical search results. A complete set of electrical applications is provided in the actual search. Move your cursor over the thumbnail image of the item to view an enlarged image and description of the product. To the right of each electrical item are viewing options such as DWG, RFA, DXF, PDF, and Word files.

The screenshot displays the Autodesk Seek web application. At the top, there is a search bar with the text 'electrical fixtures' and a 'Search' button. To the right of the search bar, there are links for 'Sign In', 'Join Now!', 'Demo', 'FAQ', and 'Support Forum'. Below the search bar, there is a 'Filter' section on the left with expandable categories: 'Category' (Electrical Components - Con... (4), Electrical Fixtures (22), Electrical (2), More >>), 'Content Source' (Generic (31)), 'Product Libraries' (Revit Architecture (24), Revit MEP (7)), and 'File Type' (RFA (31)). The main content area shows search results for 'Product | Manufacturer'. It includes a pagination bar ('Now showing 1-20 of 31 entries'), 'View Options' (grid, list), and a 'Sort by' dropdown set to 'Relevance'. The results list four items, each with a thumbnail, title, source, and file type: 'Electrical Fixture Tag' (Library Revit Architecture, 4 RFA), 'Lighting Fixture Tag' (Library Revit Architecture, 4 RFA), 'Outlet Floor-Duplex' (Library Revit Architecture, 4 RFA), and 'Outlet Floor-Single' (Library Revit Architecture, 4 RFA). A 'Why BIM?' banner is visible in the top right corner of the interface.

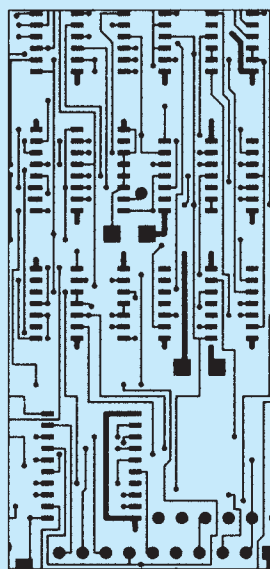
FIGURE 20.92 The browser open with a sample of electrical search results displayed using Autodesk® Seek.

(Continued)

## COMPUTER-AIDED ENGINEERING (CAE)

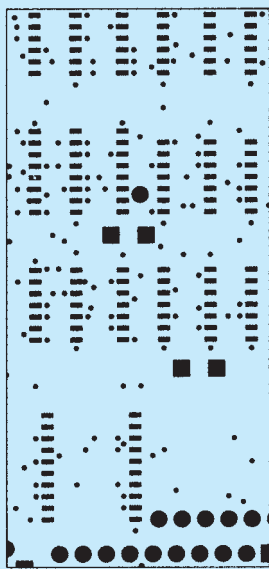
The design and layout of block diagrams, schematic diagrams, and other electronics drawings are greatly improved with electronic symbols established in a CADD template or symbols library. The use of computers in this industry has advanced into what is known as **computer-aided engineering (CAE)**, where the CADD function is taken further into the complete design, engineering, and functional analysis of the product. Beginning with the development of a computer-aided schematic design, the CAE program can perform the following functions:

- Simulate the circuit operation.
- Test the system for possible problems.
- Identify and analyze design complexity to help reduce manufacturing costs.
- Evaluate thermal characteristics of the circuitry to identify possible overheating situations where heat sinks may be needed or mechanical cooling is required.
- Automatically place arced or 45° corners rather than sharp corner conductor traces during the routing process.
- Create artwork masters generated at 1:1 scale for all circuit levels, eliminating costly and possible error-prone photo reduction as shown in Figure 20.93.
- Generate the solder resist mask from the same database as the artwork master. This improves the manufacturability of the board and reduces external changes (see Figure 20.94).
- Extract the component layout that is created as part of the symbols to create a marking drawing silk screen master as shown in Figure 20.95.
- Generate the drill template from the same database as the artwork master and determine plating requirements, including a drill chart with sizes, quantities, X–Y coordinate location dimensions, and a drill pattern or provide direct communication to a CNC drilling machine to achieve repeatable board-to-board registration.
- Place a description and reference designator on each symbol and simultaneously complete assembly drawings, parts lists, and other documentation.
- Use a large-format digitizing table to enable the designer to go from rough layout or existing works for design directly on screen.
- Use laser-directed photo plotters to provide PCB artwork with accuracy tolerances up to 0.4 mil (0.00010 mm) along with image quality and speed that exceed the highest industry standards.
- Perform printed circuit conductor routing automatically with completion on success on most boards of 97–100%. In complex board design, the incomplete part of the trace routing, if any, can be quickly engineered in the manual mode.
- Stop the routing process at any time to make component or connection changes and restart the automatic routing process at the new location.
- Design component locations along with trace routing.



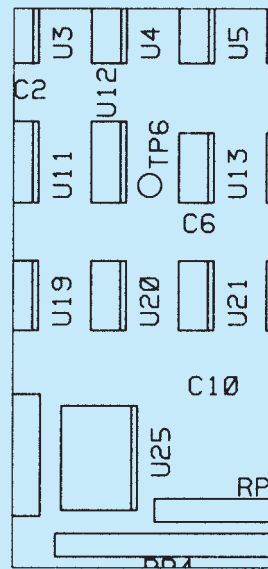
Courtesy The Gerber Scientific Instrument Company

**FIGURE 20.93** Full-scale CAE artwork, eliminating the need to photo reduce.



Courtesy The Gerber Scientific Instrument Company

**FIGURE 20.94** The solder resist mask is generated from the same database as the artwork master shown in Figure 20.93.



Courtesy The Gerber Scientific Instrument Company

**FIGURE 20.95** Marking drawing created from symbols library used to design the artwork master.

(Continued)



## ELECTRONIC DESIGN AUTOMATION

Electronic design automation (EDA) or electronic computer-aided design (ECAD) is a group of software tools for designing electronic systems such as printed circuit boards and integrated circuits. The tools allow electronics manufactures to design and analyze semiconductor chips. EDA software tools provide for a variety of applications from design, **simulation**, **analysis** and **verification**, and manufacturing preparation. The term *simulation* refers to the use of a computer-generated system to represent the behavior of a proposed system. Variables in the program can be adjusted to simulate varying conditions in the system. The term *analysis* refers to the examination and evaluation of the important information to select the best course of action from various alternatives. The term *verification* refers to the process of determining whether the results of the analysis fulfill the design requirements.

The following is a brief listing of the major companies involved with EDA:

- Synopsys, Inc. ([www.synopsys.com](http://www.synopsys.com)) is one of the largest companies in the EDA industry. Synopsys offers a wide range of other products used in the design of an application-specific integrated circuit. The Synopsys Design Compiler product is a logic-synthesis tool. A logic-synthesis tool provides a process of converting a high-level description of the design into the best representation given a set of design constraints. Synopsys simulators include development and debugging environments that assist in the design of the logic for chips and computer systems.
- Cadence Design Systems, Inc. ([www.cadence.com](http://www.cadence.com)) is an EDA software and engineering services company. Cadence products provide a wide range of design tools from system design and verification to logic design and custom integrated circuit design. The OrCAD product provides EDA tools for smaller design teams and individual PCB designers with affordable applications.
- Mentor Graphics, Inc. ([www.mentor.com](http://www.mentor.com)) is a United States-based multinational EDA corporation for electrical engineering and electronics. Mentor Graphics products provide a wide range of design tools from electrical and wire harness design to integrated circuit design to vehicle systems design.
- Zuken, Inc. ([www.zuken.com](http://www.zuken.com)) is a Japanese multinational corporation specializing in software solutions and consulting services for electrical and electronic engineering. Zuken's software is primarily used for designing PCBs and multichip modules and for engineering electrotechnical wiring, wiring harness, pneumatics, and hydraulics applications. Recently, Zuken has been developing solutions for optimized design based on collaboration between EDA and mechanical design automation (MDA) and between EDA and product life cycle management (PLM).
- Magma Design Automation ([www.magma-da.com](http://www.magma-da.com)) is a software company in the EDA industry. Magma software products are used in major elements of chip development, including synthesis, placement, routing, power management, circuit simulation, verification, analog, and mixed-signal design.

## PROFESSIONAL PERSPECTIVE

As an entry-level drafter with training in electronics schematic drafting, you are able to make engineering drawing changes and prepare drawings from engineering sketches without specific knowledge of how electronic components and the systems function. However, to advance in skill level to designer or engineering technician, you need a thorough understanding of company requirements, the ability to communicate electrical and electronic terminology, and the knowledge of how the components go together. It is important for an engineering drafter in this business to visualize the systems and understand electrical clearance

requirements. You will learn a significant amount on the job, and you can assist in identifying engineering problems and troubleshooting systems as you gain experience. Schooling in communication skills and problem-solving techniques, along with electrical and electronic theory and practices, is essential. Helpful college courses in addition to your electronic drafting include:

- Basic AC/DC electronics.
- Solid-state devices.
- Digital logic.
- Basic microprocessors.
- Electrical physics.

When you go to work in the electronics engineering field, you will find that it is extremely important for you to check your work completely, making sure that electrical connections made are necessary. Nearly all drafting is done on a CADD system, so it is important for you to understand the computer operating systems fully. When you are bringing electronic symbols from a menu library, be sure that you leave adequate space to display the symbol, labeling, and circuit notations. Be sure that you set up the schematic in a logical layout sequence

so the components, test points, and other items are identified from left to right and top to bottom. You need to know and understand the numbering systems relating to the schematic and the PCB design. This is all part of the knowledge you will gain with experience in the industry. An engineering drafter at Intel Corporation has this advice: “Keep an open mind on new CADD systems and better ways to do things. The hardest part of the job is to learn new systems constantly, because the industry changes so fast. To sum it up, be flexible.”

## WORKING WITH POWERS OF TEN

Powers of ten, or scientific notation, are used to express the very large and small numbers found in electronics compactly, making multiplying or dividing them much easier. Here are some of the powers of ten.

$$\begin{aligned} 10^4 &= 10,000 \\ 10^3 &= 1000 \\ 10^2 &= 100 \\ 10^1 &= 10 \\ 10^0 &= 1 \\ 10^{-1} &= .1 \\ 10^{-2} &= .01 \\ 10^{-3} &= .001 \end{aligned}$$

A number can be changed to a power of ten form by first writing the digits as a number between 1 and 10 and then multiplying it by the appropriate power of ten. Here are some examples to illustrate this:

$$\begin{aligned} 3400 &= 3.4 \times 10^3 \\ 53,000,000 &= 5.3 \times 10^7 \\ .000051 &= 5.1 \times 10^{-5} \\ .02 &= 2 \times 10^{-2} \end{aligned}$$

**To Multiply:** Multiply the numbers out front and add the exponents.

**To Divide:** Divide the numbers out front and subtract the exponent in the bottom from the exponent on top.

Here are examples to illustrate:

$$\begin{aligned} (2 \times 10^3) (7 \times 10^8) &= 14 \times 10^{11} = 1.4 \times 10^{12} \\ (3 \times 10^{-6}) (2 \times 10^5) &= 6 \times 10^{-6+5} = 6 \times 10^{-1} \\ (5 \times 10^{-20}) (7 \times 10^{-3}) &= 35 \times 10^{-23} = 3.5 \times 10^{-22} \end{aligned}$$

These results can be obtained on the calculator using the EE, EXP, or EEX buttons, depending on the model of your calculator. For the last example, many calculators use this sequence of buttons to obtain the final answer: 1.4 EE ÷ 15 2 EE 5 +/- =. The calculator can display the answer without the “× 10” like this: 7<sup>19</sup>. However, the answer should never be written down and communicated like this because it can be confused with 7 raised to the 19th power, which is an entirely different number! Always include the “× 10” when writing down a power of 10 number.

## WEB SITE RESEARCH

Use the following Web sites as a resource to help find more information related to engineering drawing and design and the content of this chapter.

Address	Company, Product, or Service
seek.autodesk.com	Autodesk Seek Web service
www.asme.org	American Society of Mechanical Engineers (ASME)
www.cadence.com	Cadence Design Systems, Inc. software
www.iec.ch	International Electrotechnical Commission (IEC)
www.ieee.org	Institute of Electrical and Electronics Engineers (IEEE)
www.ipc.org	Association Connecting Electronics Industries (IPC)

(Continued)

www.magma-da.com  
 www.mentor.com  
 www.skystreamenergy.com  
 www.synopsys.com  
 www.windenergy.com  
 www.zuken.com

Magma Design Automation  
 Mentor Graphics, Inc., software  
 Southwest Windpower Skystream  
 Synopsys, Inc., software  
 Southwest Windpower  
 Zuken Inc. software

## Chapter 20

### Chapter 20 Electrical and Electronic Drafting Test



To access the Chapter 20 test, go to the Student CD, select **Chapter Tests and Problems**, and then **Chapter 20**. Answer the questions

with short, complete statements, sketches, or drawings as needed. Confirm the preferred submittal process with your instructor.

### Chapter 20 Electrical and Electronic Drafting Problems

#### INSTRUCTIONS

1. Read all instructions before you begin working, unless otherwise specified by your instructor.
2. Use the attached engineering layouts to prepare each drawing. Refer to chapter coverage for symbol and component dimensions and refer to previous drawings for information as you progress to each drawing.
3. Use an ASME Y14.1 or ASME Y14.1M standard border and title block unless otherwise specified in the problem instructions or by your instructor.
4. Prepare well-balanced, easy-to-read drawings. Most drawings have no scale.
5. Many of the following problems contain symbols that are duplicated multiple times. These electrical problems demonstrate the power of CADD when you create one symbol and have the ability to use it several times on one or more drawings.
6. Additional information is provided for some problems.
7. Estimate unknown dimensions based proportionally on given features and dimensions.

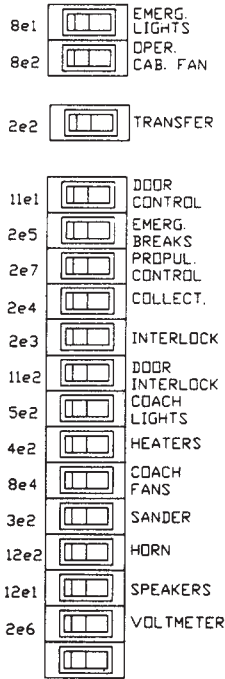


#### Drafting Templates

To access CADD template files with predefined drafting settings, go to the Student CD, select **Drafting Templates**, and then select the appropriate template file. Use the templates to create new designs, as a resource for drawing and model content, or for inspiration when developing your own templates. Use the ASME-Inch and ASME-Metric drafting templates that follow ASME, ISO, and related mechanical drafting standards for electronic drawing problems, unless otherwise specified by your instructor. Use architectural-style templates for electrical problems, unless otherwise specified by your instructor. Drawing templates include standard sheet sizes and formats, and a variety of appropriate drawing settings and content. You can also use a utility such as the AutoCAD Design-Center to add content from the drawing templates to your own drawings and templates. Consult with your instructor to determine which template drawing and drawing content to use.

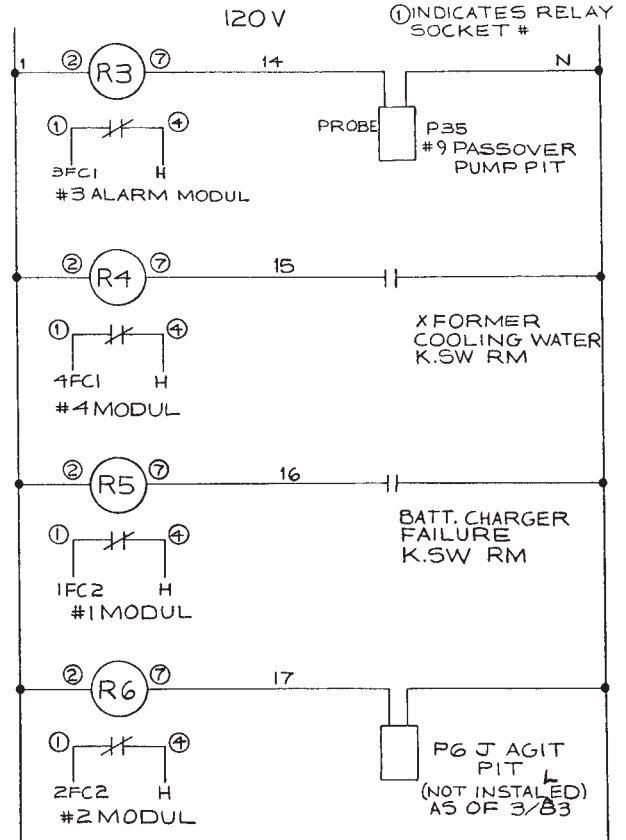
Part 1: Problems 20.1 Through 20.10

PROBLEM 20.1 Switch panel



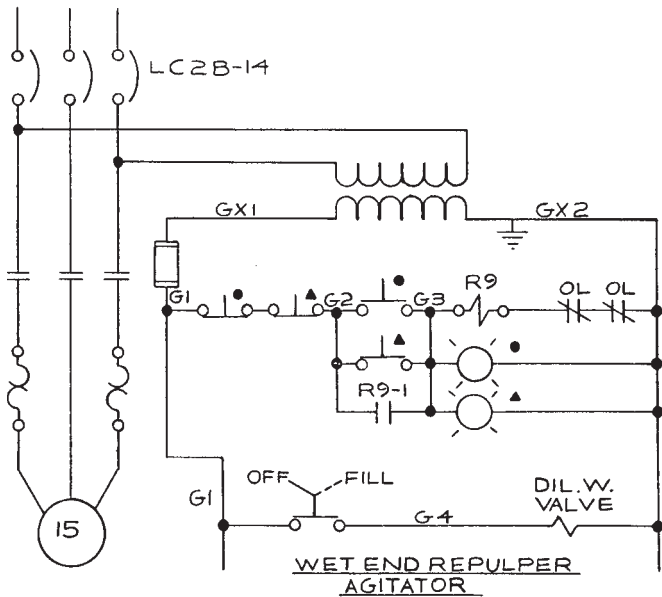
© Cengage Learning 2012

PROBLEM 20.3 Schematic



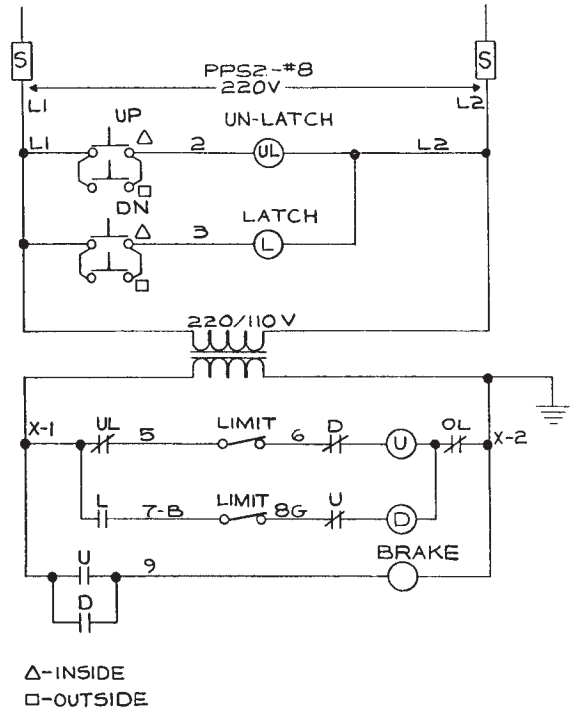
© Cengage Learning 2012

PROBLEM 20.2 Schematic



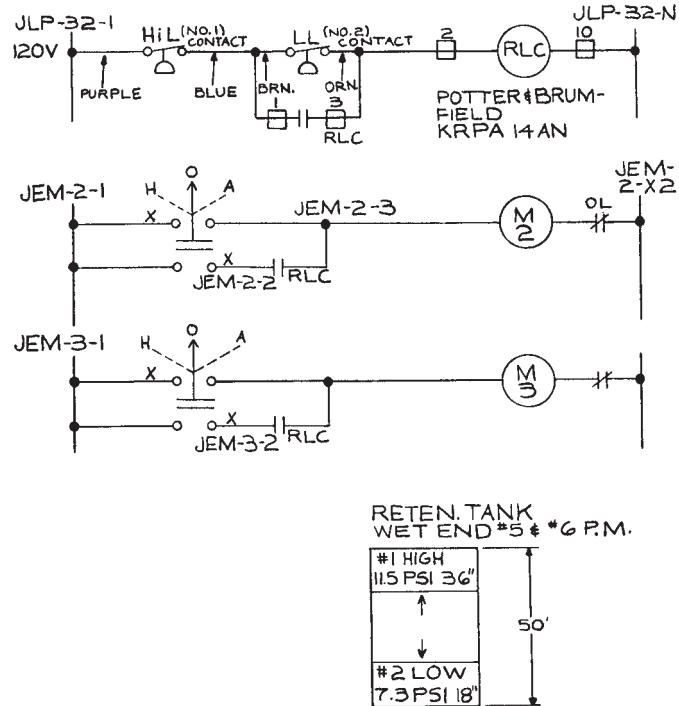
© Cengage Learning 2012

PROBLEM 20.4 Schematic

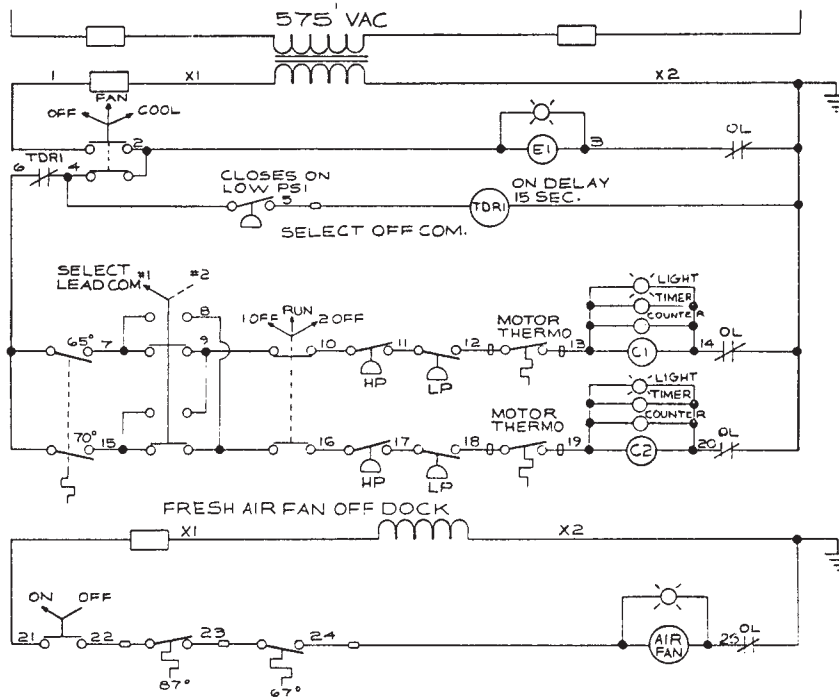


© Cengage Learning 2012

PROBLEM 20.5 Schematic



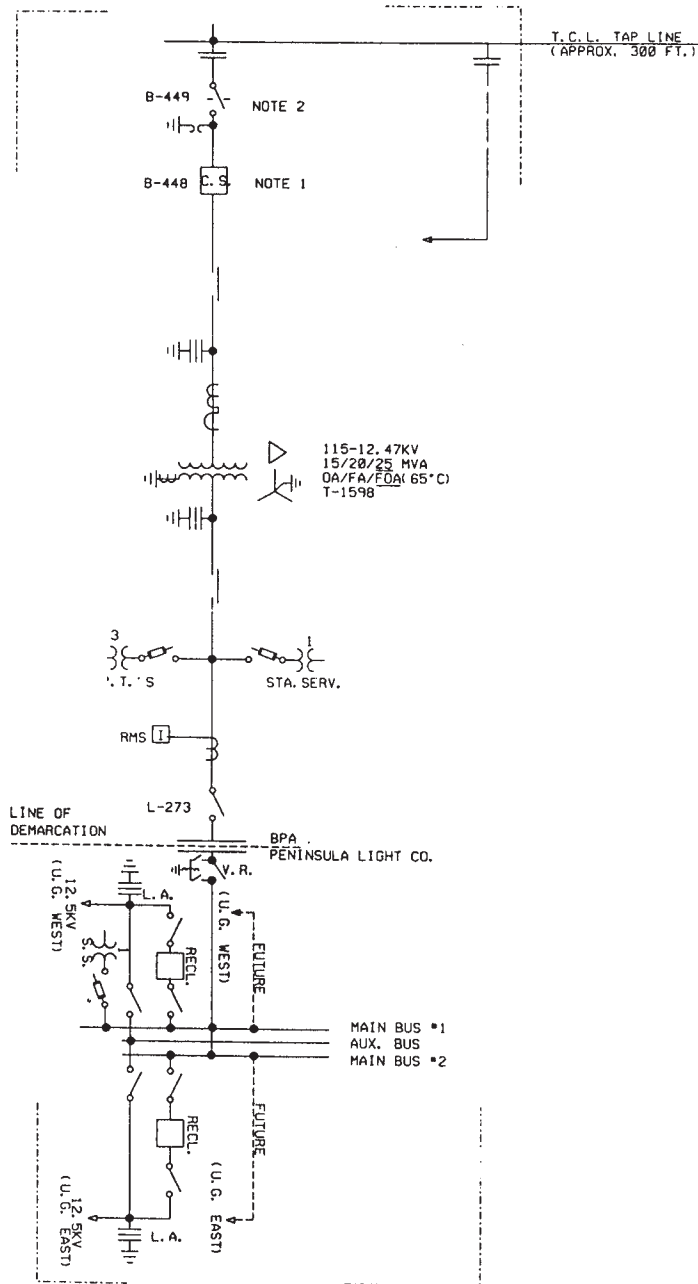
PROBLEM 20.6 Schematic



**PROBLEM 20.7 Block diagram**

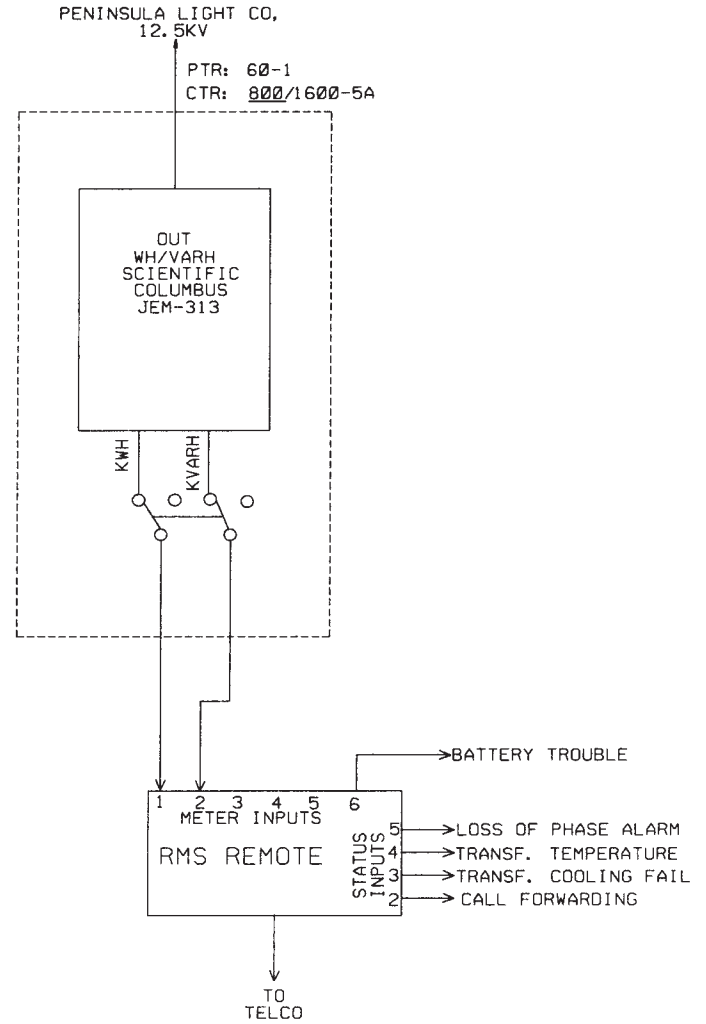
Given the following engineering layout of the Potlatch-Pearl Substation, draw the block diagram on an 11 × 17 sheet with an architectural-style border and title block unless otherwise specified by your instructor. Sheets with borders and title blocks are found as templates on the CD provided with this textbook. There is no scale. The layout should neatly fill the sheet without crowding symbols or notes. Make all connection points Ø3/32 in. Provide the general note INTERPRET PER ANSI Y32.2.

*Courtesy Bonneville Power Administration*



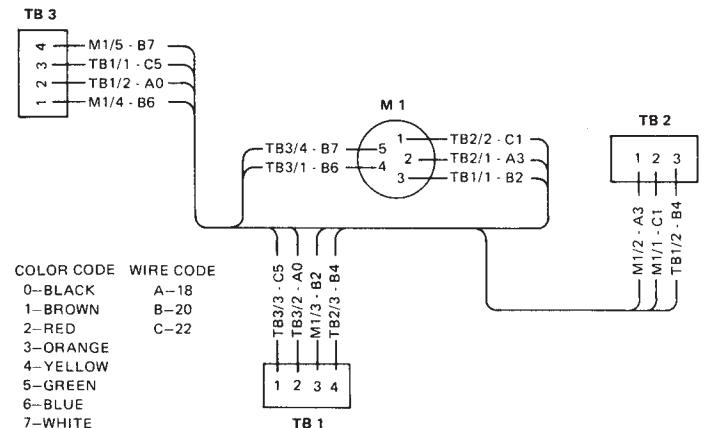
**PROBLEM 20.8 Elementary diagram**  
Metering System.

*Courtesy Bonneville Power Administration*

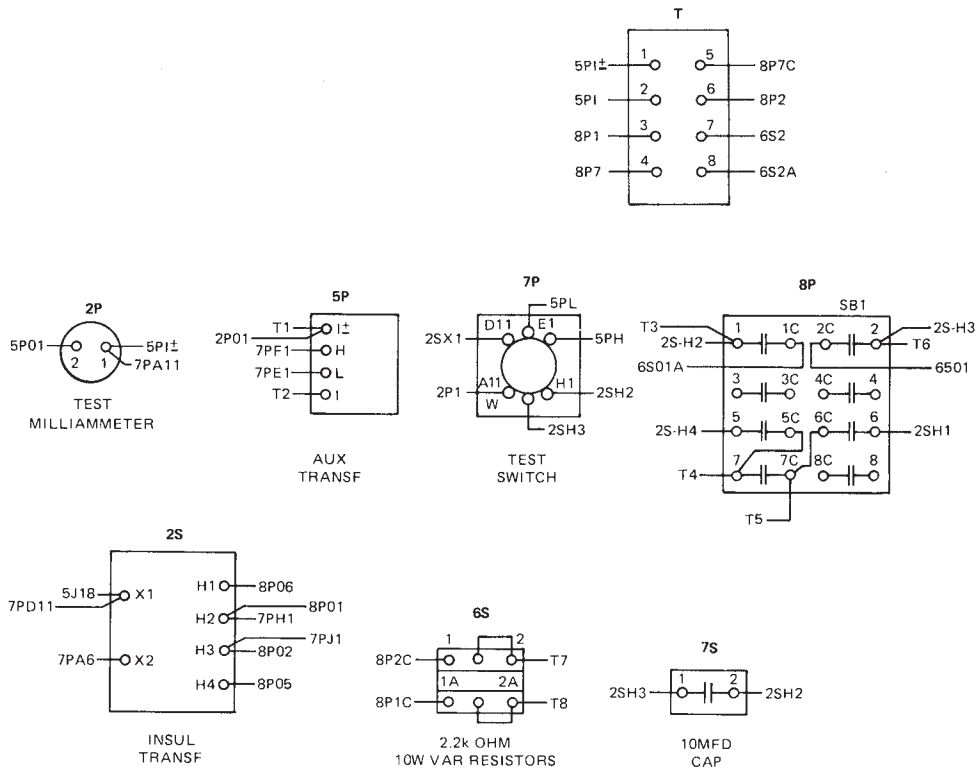


**PROBLEM 20.9 Highway diagram**

Draw all component outlines and feeder lines .020 in. (0.5 mm) wide and trunk lines .039 in. (1.00 mm) wide.



PROBLEM 20.10 Wireless diagram



© Cengage Learning 2012

Part 2: Problems 20.11 Through 20.15

To access the Chapter 20 problems, go to the Student CD, select **Chapter Tests and Problems** and **Chapter 20**, and then open

the problem of your choice or as assigned by your instructor. Solve the problems using the instructions provided on the CD, unless otherwise specified by your instructor.

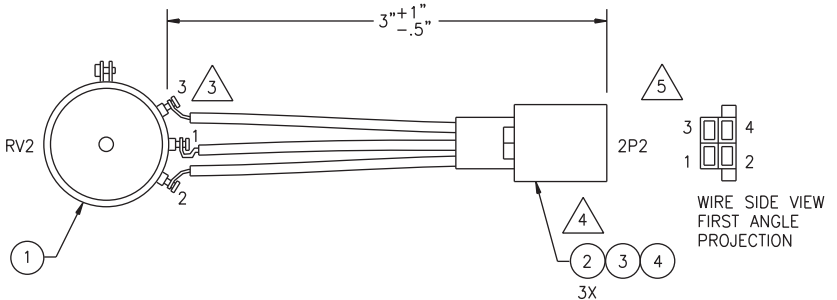
Part 3: Problems 20.16 Through 20.34

PROBLEM 20.16 Wiring harness

Courtesy Flir Systems, Inc.

1. INTERPRET DRAWING IAW MIL-STD-100, CLASSIFICATION PER MIL-T-31000, PARA 3.6.4.
2. DIMENSIONS AND TOLERANCES PER ASME Y14.5-2009.

- COVER SOLDER JOINTS USING ITEM 8 (TUBING-SHRINK 3/16").
- PREP WIRES AND ASSEMBLE CONTACTS PER XXXXXXXX.
- MARK REFERENCE DESIGNATORS ON HOUSING PER MIL-M-13231.
6. BAG ITEM AND IDENTIFY IAW MIL-STD-130, INCLUDE CURRENT REV LEVEL: 64869ASSYXXXXXXX REV\_.



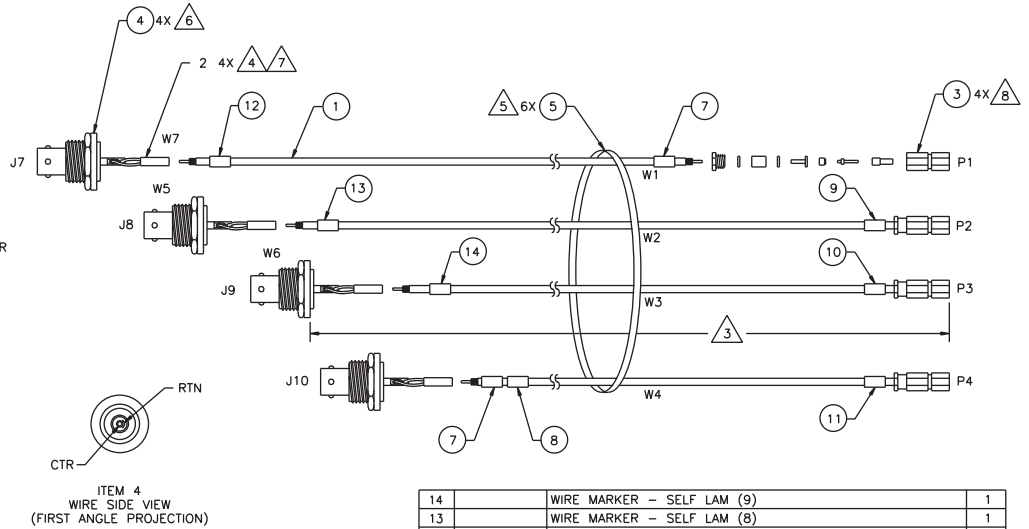
WIRE LIST				
WIRE #	GA/COLOR/ITEM	FROM	TO	SIGNAL
1	22/ORN/6	RV2-1	2P2-2	AZ +12V
2	22/GRN/7	RV2-2	2P2-3	AZ REF
3	22/BLU/5	RV2-3	2P2-4	AZ -12V
UNUSED POSITIONS: J3-D, E, F				

8	TUBING - SHRINK 3/16" BLK	.75"
7	WIRE - #22 STRD, TFE, GRN	4"
6	WIRE - #22 STRD, TFE, ORN	4"
5	WIRE - #22 STRD, TFE, BLU	4"
4	SHROUD - LATCHING DOUBLE ROW 4 POS	1
3	HOUSING - .025 SQ DUAL 4 POS LATCH	1
2	CONTACT - CRIMP PIN .025 SQ 22-26 GA	3
1	RESISTOR - VARI, 10K OHM SERVO MOUNT	1

**PROBLEM 20.17** Wiring harness

Courtesy Flir Systems, Inc.

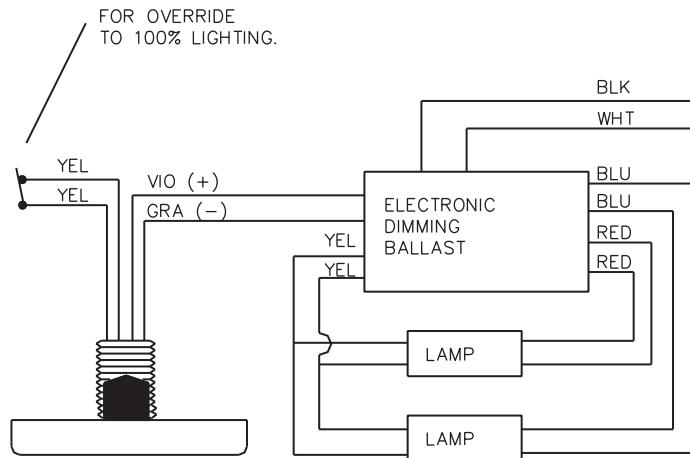
1. INTERPRET DRAWING IAW MIL-STD-100, CLASSIFICATION PER MIL-T-31000, PARA 3.6.4.
2. DIMENSIONS AND TOLERANCES PER ASME Y14.5M-2009.
3. OVERALL FINISHED LENGTH:
  - W1 = 15.5"±1"
  - W2 = 14"±1"
  - W3 = 12.5"±1"
  - W4 = 11"±1"
4. ASSEMBLE PER STD XXXXXXXX.
5. ALIGN P1, P2, P3, & P4. INSTALL FIRST CABLE TIE (ITEM 5) 2" MINIMUM FROM P1. EQUALLY SPACE REMAINING CABLE TIES.
6. DISCARD SOLDER TAIL.
7. INSTALL 1/2" OF ITEM 6 (TUBING - SHRINK 1/8") OVER EACH SOLDER TERMINATION ON ITEM 4 (CONNECTOR).
8. PREP AND ASSEMBLE ITEM 3 (CONNECTOR - COAX) PER PREP STD XXXXXXXX.
9. BAG ITEMS AND IDENTIFY IAW MIL-STD-130, INCLUDE CURRENT REV LEVEL: 64869ASSYXXXXXXX REV\_\_.



WIRE LIST					
WIRE	COLOR	FROM	TO	SIGNAL	CUT LENGTH
W1	WHT	J7-CTR	P1	CENTER	15.5"
W1	WHT/BLK	J7-RTN	P1	SHIELD	15.5"
W2	WHT	J8-CTR	P2	CENTER	14"
W2	WHT/BLK	J8-RTN	P2	SHIELD	14"
W3	WHT	J9-CTR	P3	CENTER	12.5"
W3	WHT/BLK	J9-RTN	P3	SHIELD	12.5"
W4	WHT	J10-CTR	P4	CENTER	11"
W4	WHT/BLU	J10-RTN	P4	SHIELD	11"

14	WIRE MARKER - SELF LAM (9)	1
13	WIRE MARKER - SELF LAM (8)	1
12	WIRE MARKER - SELF LAM (7)	1
11	WIRE MARKER - SELF LAM (4)	1
10	WIRE MARKER - SELF LAM (3)	1
9	WIRE MARKER - SELF LAM (2)	1
8	WIRE MARKER - SELF LAM (0)	1
7	WIRE MARKER - SELF LAM (1)	2
6	TUBING - SHRINK 1/8"	4"
5	CABLE TIE - SELF LOCK .094 W X 3.62 L	6
4	CONNECTOR - TRIAX BULKHEAD INSULATED SOLDER TAIL	4
3	CONNECTOR - COAX (RG179/U), SCREW-ON	4
2	TERMINATION SLEEVE - COAX, RG316/U	4
1	CABLE - COAX, 75 OHM, RG179	56"

**PROBLEM 20.18** Photocell wiring diagram

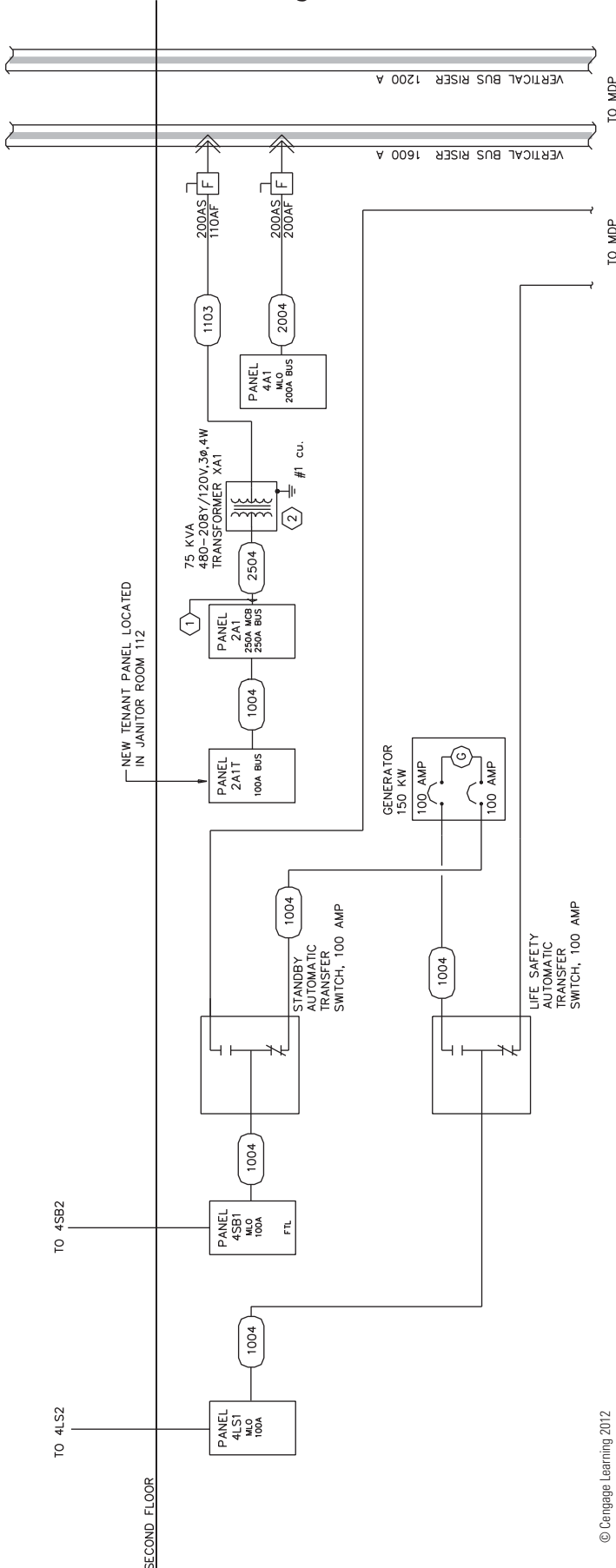


**2** PHOTOCELL WIRING DIAGRAM  
E1 NO SCALE

© Cengage Learning 2012



**PROBLEM 20.19** Block diagram



**PROBLEM 20.20** Cable assembly

Given the cable assembly engineering layout in Figure 20.12, page 814, do the following:

1. Draw the cable assembly, wiring diagram, and bill of materials.
2. Approximate dimensions that are not given.
3. Use an appropriate sheet size of your choice and an ASME style border and title block. Sheets with borders and title blocks are found as templates on the CD provided with this textbook.
4. Use ASME standard line widths for cable assembly and 0.5 mm lines for wiring diagram.
5. Use .12 in. (3 mm) lettering with .24 in. (6 mm) high letters in balloons and titles.
6. Make balloons  $\varnothing 1/2$  in. (25 mm).
7. Letter the following general notes:
  1. DIMENSIONS AND TOLERANCES PER ASME Y14.5-2009.
  2. INTERPRET DRAWING PER IEEE 315A.
  3. DIMENSIONS ARE IN INCHES WITH TOLERANCES: FRACTIONS =  $\pm 1/64$ , =  $\pm .XX .010$ , .XXX =  $\pm .005$ .
  4. 32 MICRO IN FINISH ON METAL PARTS.
  5. MATERIAL BRONZE.
  6. USE SPEC 6712 FOR WIRE END PREPARATION.

**PROBLEM 20.21** Bus layout plan view

Given the engineering layout shown in Figure 20.16, page 817, for the Narrows substation, draw the bus layout using a  $3/16" = 1'-0"$  (1:50 metric) scale. Use an architectural-style border and title block. The following line widths are recommended:

- .014 in. (0.35 mm) Extension, dimension, balloon lines, all connections
- .020 in. (0.50 mm) Component and bus lines and lettering
- .024 in. (0.60 mm) Titles

Draw balloons  $\varnothing 9/32$  in. (7–8 mm). Draw north arrow S45° W. Draw bus lines from given dimensions and fill in solid except for connections. Estimate dimensions not given.

**PROBLEM 20.22** Bus elevations

Given the partial engineering layout shown in Figure 20.17, page 817, for the Narrows substation, draw the bus elevation. Follow all other instructions given in Problem 20.21.

**PROBLEM 20.23** Grounding layout

Given the partial engineering layout shown in Figure 20.19, page 819, of the Narrows substation, draw the grounding layout at a scale of  $1" = 10'-0"$  (1:100 metric). Include notes and grounding table. Follow all other instructions given in Problem 20.21.

© Cengage Learning 2012

**PROBLEM 20.24 Grounding details**

Given the partial engineering layout shown in Figure 20.20, page 819, of the Narrows substation, draw the grounding detail. Follow all other instructions given in Problem 20.21.

**PROBLEM 20.25 Conduit installation layout**

Given the partial engineering layout shown in Figure 20.21, page 820, of the Narrows substation, draw the conduit installation layout. A magnifying glass may be needed to read the engineering layout. Follow all other instructions given in Problem 20.21.

**PROBLEM 20.28 Power panel detail**

Narrows substation.

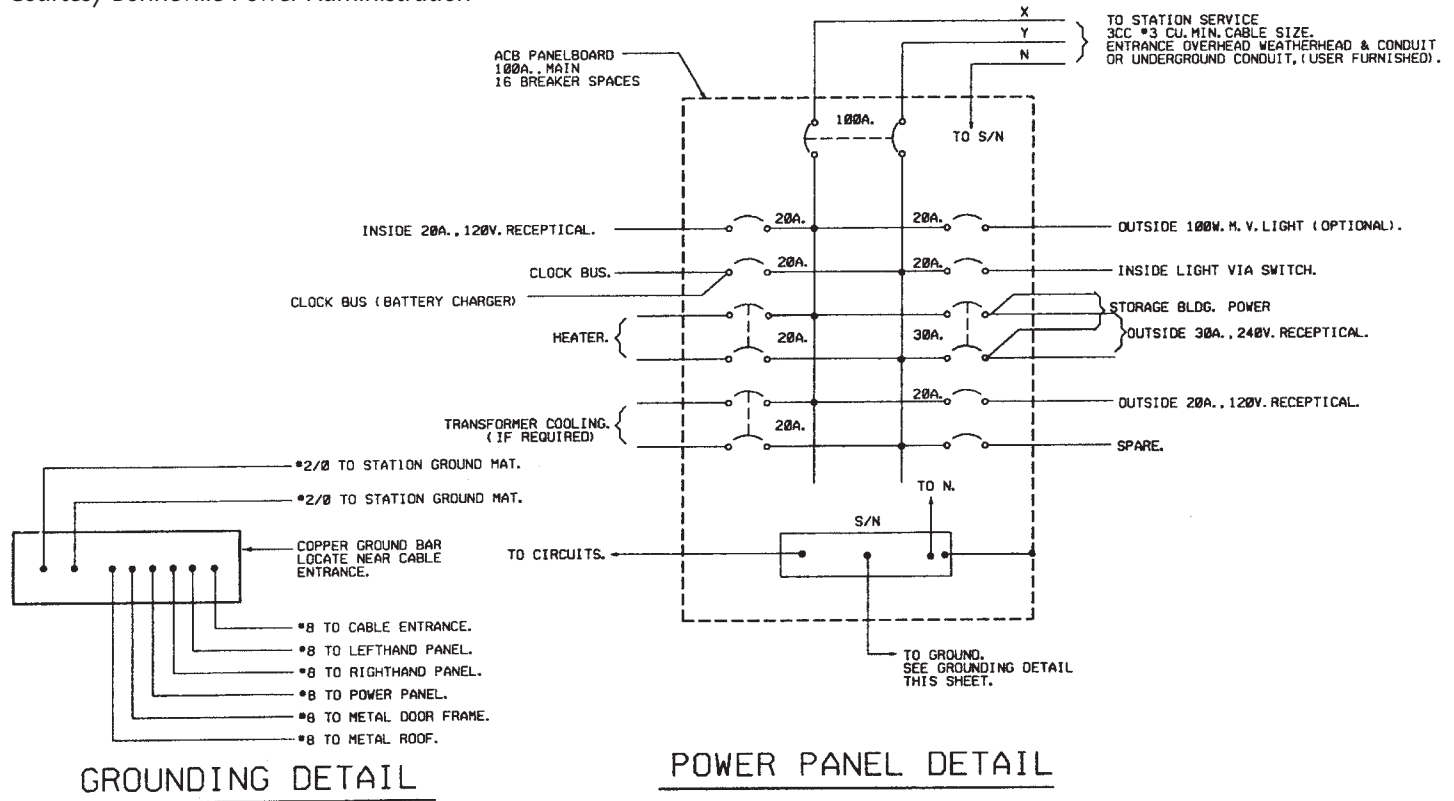
*Courtesy Bonneville Power Administration*

**PROBLEM 20.26 Conduit installation details**

Given the partial engineering layout of the conduit installation detail shown in Figure 20.22, page 820, for the Narrows substation, draw the given views. Follow all other instructions given in Problem 20.21.

**PROBLEM 20.27 Residential electrical**

Given the typical electrical layouts shown in Figures 20.29 and 20.30, page 823, draw each one at a scale of 1/4" = 1'-0" (1:50 metric). Place one next to the other. Estimate dimensions making your drawing about twice the size of the given drawing. Use an architectural-style border and title block.



**PROBLEM 20.29 Electrical floor plan**

Given the partial engineering upper-floor power layout shown in Figure 20.34, page 823, draw the plan using a 1/4" = 1'-0" (1:50 metric) scale. Estimate dimensions, making your drawing about three times the size of the given drawing. Use an architectural-style border and title block.

**PROBLEM 20.31 Roof plan—electrical**

Given the partial engineering layout shown in Figure 20.36, page 824, draw the roof plan—electrical at a 1/4" = 1'-0" (1:50 metric) scale. Estimate unknown dimensions. Use an architectural-style border and title block.

**PROBLEM 20.30 Reflected ceiling plan**

Given the engineering layout shown in Figure 20.35, page 824, draw the reflected ceiling plan at a 1/4" = 1'-0" (1:50 metric) scale. Estimate unknown dimensions. Use an architectural-style border and title block.

**PROBLEM 20.32 Commercial schematic wiring diagram**

Given the engineering layout shown in Figure 20.37, page 824, draw the beverage cooler condenser unit wiring diagram.

**PROBLEM 20.33 First-floor lighting plan**

Use the given problem layout to create the partial lighting plan shown. Use a 1/4" = 1'-0" (1:50 metric) scale to draw the floor plan. Make the dimensions to your own specifications but proportional to the given engineering drawing. Use appropriate CADD layers. Use an architectural-style border and title block.

*Courtesy Interface Engineering*

## LUMINAIRE SCHEDULE

TYPE 'A': RECESSED FLUORESCENT PARABOLIC LUMINAIRE. 2' BY 4'  
STEEL HOUSING. LUMINAIRE PROVIDED BY LANDLORD.  
THREE 32W T8 LAMPS.  
NOMINAL INPUT WATTS: 93.

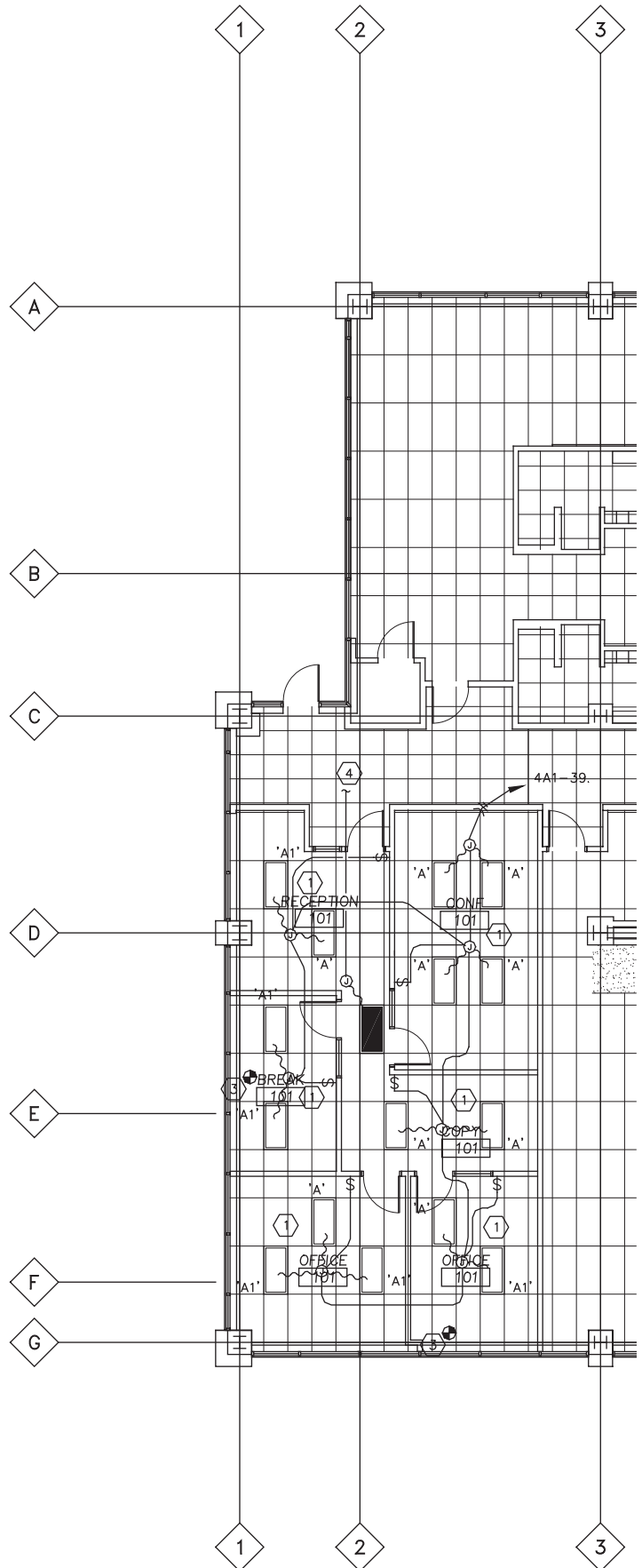
TYPE 'A1': SAME AS TYPE 'A' EXCEPT CONTINUOUS DIMMING BALLAST.

### LUMINAIRE SCHEDULE GENERAL NOTES

- 1 THIS LUMINAIRE SCHEDULE IS NOT COMPLETE WITHOUT A COPY OF THE PROJECT MANUAL CONTAINING THE ELECTRICAL SPECIFICATIONS.
- 2 T8 FLUORESCENT LAMPS TO BE 3500K WITH A MINIMUM CRI OF 75.

## NOTES THIS SHEET

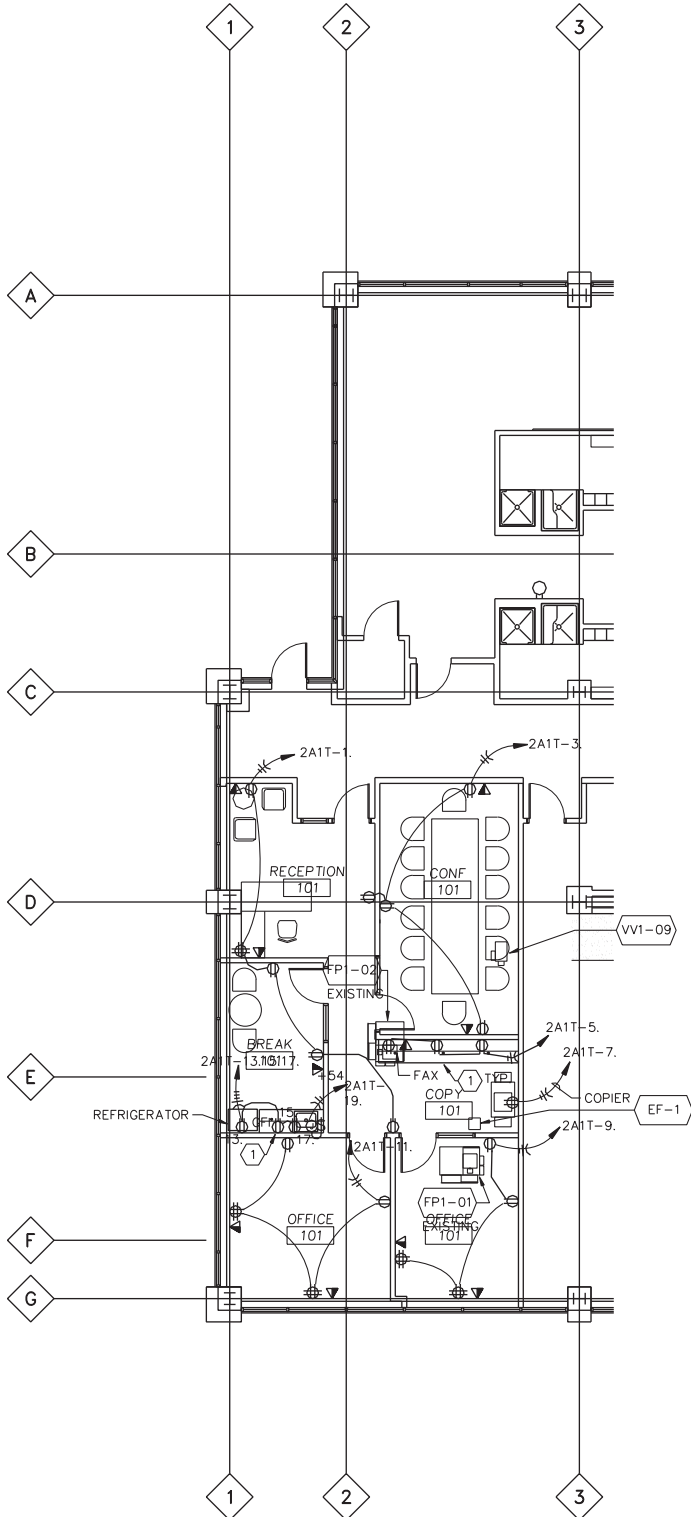
- ① 2' X 4' PARABOLIC LUMINAIRES ARE TO BE PROVIDED BY LANDLORD.
- ② TYPE 'B' LUMINAIRES LOCATED BELOW CABINETS.
- ③ PHOTO CELL TO CONTROL ALL AMBIENT SECTORS AS SHOWN ON DRAWINGS. ROUTE LOW VOLTAGE CONTROL CIRCUIT VIA PHOTOCELL. SEE DIAGRAM 2/E2. VERIFY AMOUNT AND LOCATIONS OF PHOTO CELLS WITH MANUFACTURES REP. PRIOR TO ROUGH-IN. PROVIDE WATTSTOPPER OR EQUAL.
- ④ CONNECT TO EMERGENCY LIGHTING CIRCUIT IN CORRIDOR.



**PROBLEM 20.34 First-floor power plan**

Use the partial floor plan that you drew in Problem 20.33 as a guide to create the partial power plan shown in the given engineering drawing. Use appropriate CADD layers. Use an architectural-style border and title block.

*Courtesy Interface Engineering*



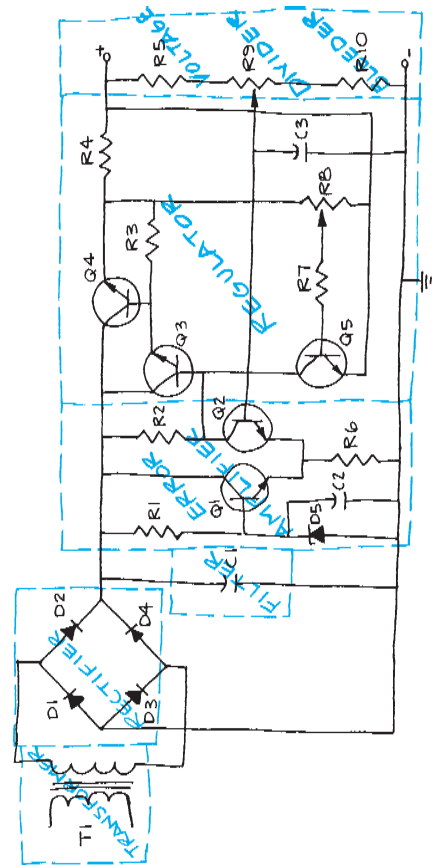
**Block and Schematic Diagrams**

**Part 4: Problems 20.35 Through 20.45**

1. Follow previous instructions unless otherwise specified.
2. Use an appropriate sheet size of your choice and an ASME-style border and title block.
3. Use the selected engineering layouts and sketches to prepare each drawing. Keep in mind that engineering sketches can contain slight errors in format and symbol accuracy. Verify proper representation before drawing each symbol.

**PROBLEM 20.35 Block diagram**

Given the schematic diagram sketch that has been divided into stages, prepare a block diagram using 11 × 17 (A3 metric) size, unless otherwise specified by your instructor. Make all lines .020 in. (0.5 mm) wide. Complete all lettering .12 in. (3 mm) high with titles .24 in. (6 mm) high. The sketch does not show connection dots.

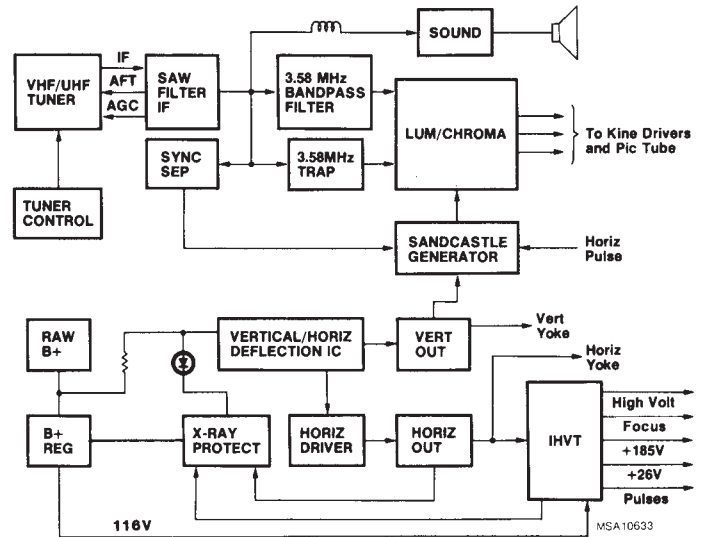


© Cengage Learning 2012

**PROBLEM 20.36 Television receiver block diagram**

Given the block diagram engineering layout, draw the block diagram using  $11 \times 17$  (A3 metric) size unless otherwise specified by your instructor. Do all lettering .12 in. (3 mm) high with titles .24 in. (6 mm) high. Use .020 in. (0.5 mm) thick lines unless otherwise specified on the engineering sketch.

Courtesy RCA Consumer Electronics

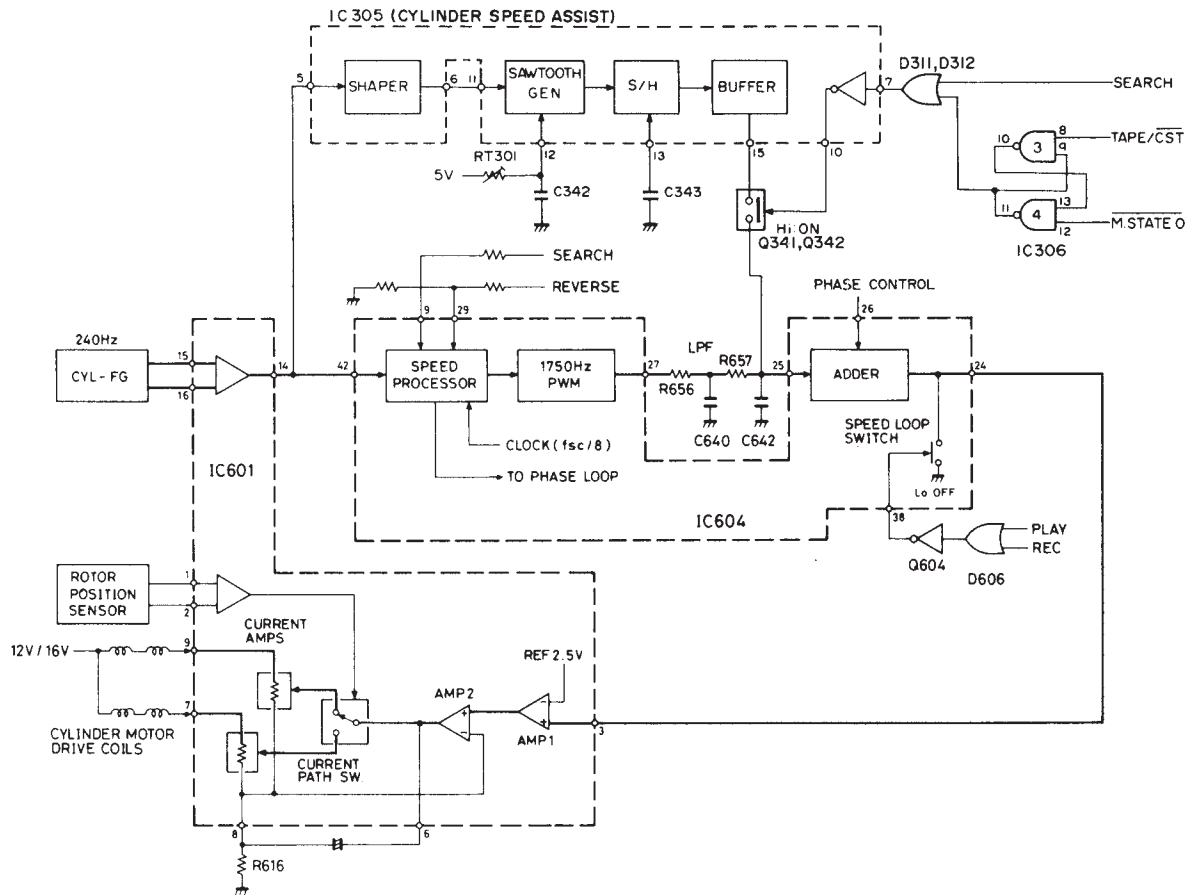


**PROBLEM 20.37 Cylinder speed block diagram**

Given the block diagram engineering layout, draw the block diagram using  $17 \times 22$  (A2 metric) size, unless otherwise specified by your instructor. Do all lettering

.12 in. (3 mm) high with titles .24 in. (6 mm) high. Use .020 in. (0.5 mm) thick lines unless otherwise specified on the engineering sketch.

Courtesy RCA Consumer Electronics

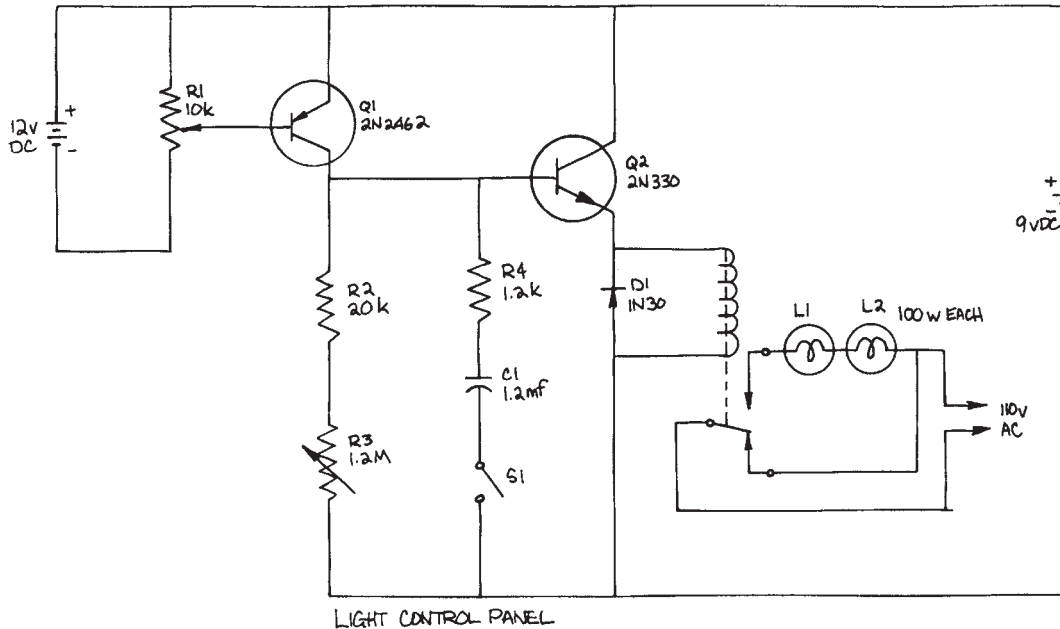


**PROBLEM 20.38 Schematic diagram**

Given the schematic engineering sketch, make a schematic diagram using 11 × 17 (A3 metric) size. There is no scale, and the drawing must be balanced, uncluttered, and easy to read. Use the following instructions unless otherwise specified by your instructor:

1. Draw the entire schematic with .020 in. (0.5 mm) wide lines.

2. Do all lettering .12 in. (3 mm) high with titles .24 in. (6 mm) high.
3. Follow the left-to-right and top-to-bottom labeling system using coding as described in this chapter: R1, R2, R3 . . . , C1, C2. . . .
4. Label horizontal components above and vertical components to the right.



© Cengage Learning 2012

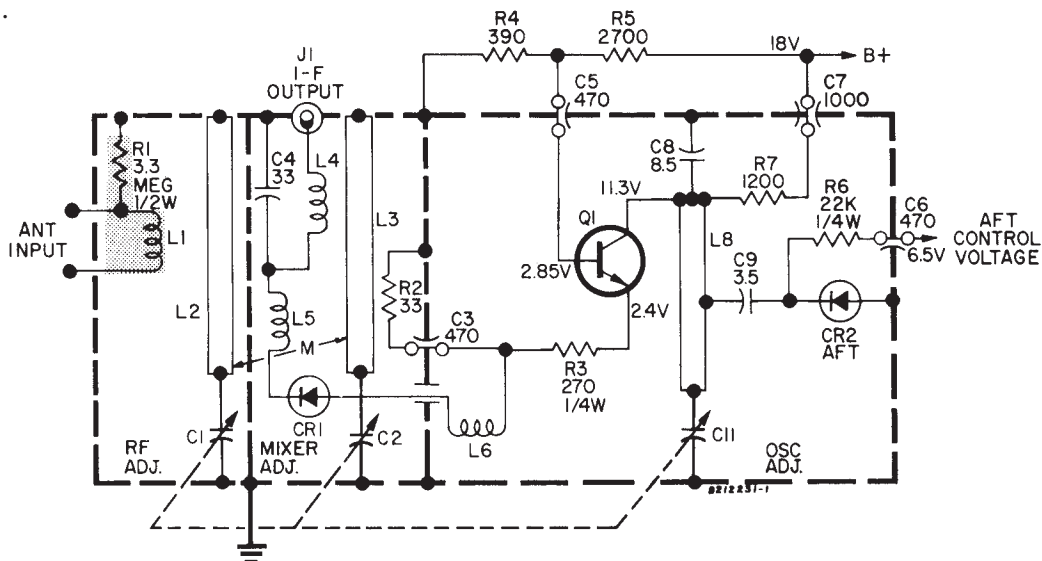
**PROBLEM 20.39 Tuner schematic diagram**

Given the schematic engineering layout, make a schematic diagram using 11 × 17 (A3 metric) size. There is no scale, and the drawing must be balanced, uncluttered, and easy to read. Use the following instructions unless otherwise specified by your instructor:

1. Draw the entire schematic with .020 in. (0.5 mm) wide lines and dashed stage lines .028 in. (0.7 mm) wide.
2. Do all lettering .12 in. (3 mm) high with titles .24 in. (6 mm) high.

3. Reference designators are not shown. Use the left-to-right and top-to-bottom labeling system, using coding as described in this chapter: R1, R2, R3 . . . , C1, C2. . . .
4. Label horizontal components above and vertical components to the right.
5. Place connection dots as necessary.

*Courtesy RCA Consumer Electronics*

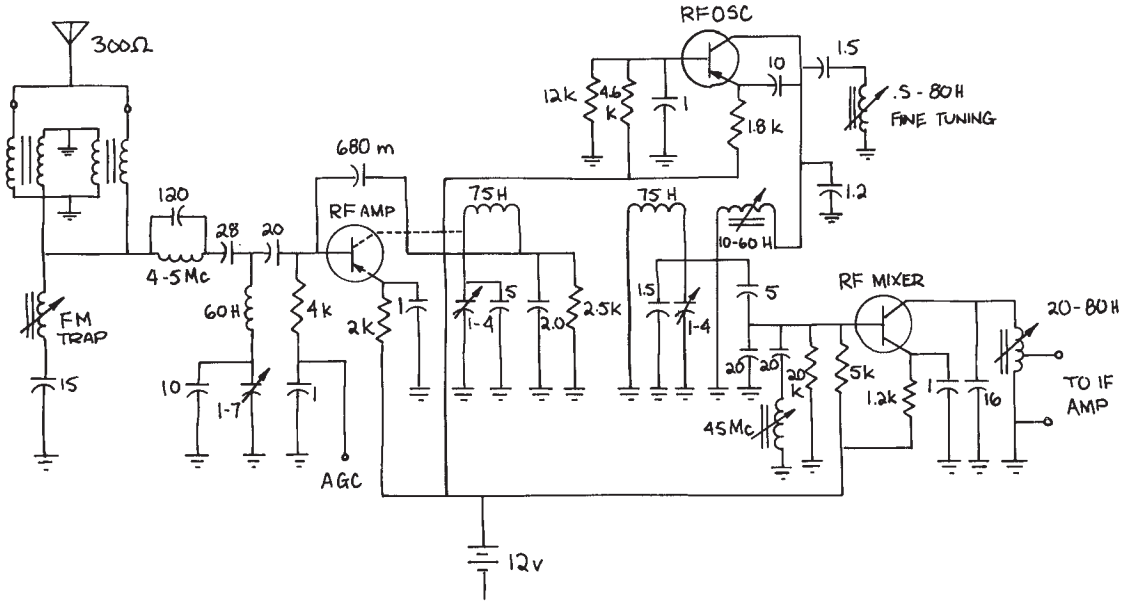


**PROBLEM 20.40 Television receiver tuner schematic diagram**

Given the schematic engineering sketch, make a schematic diagram using 17 × 22 (A2 metric) size. There is no scale, and the drawing must be balanced, uncluttered, and easy to read. Use the following instructions unless otherwise specified by your instructor:

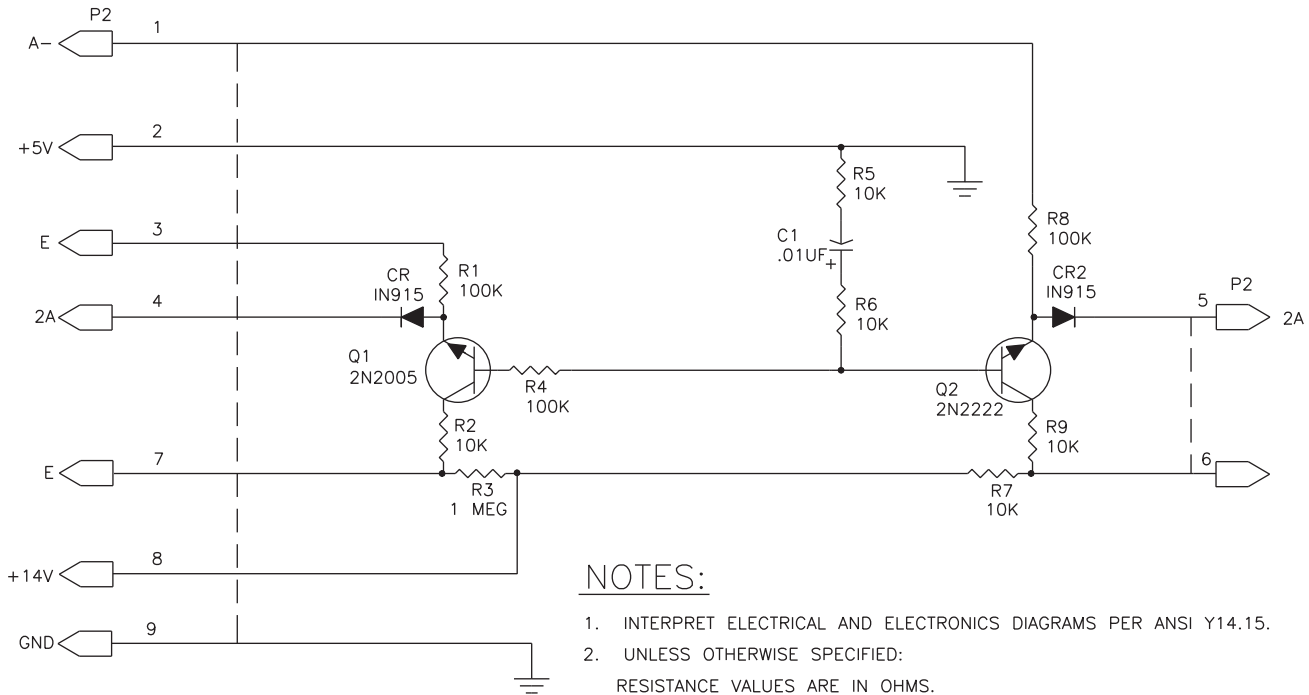
1. Draw the entire schematic with .020 in. (0.5 mm) wide lines and dashed stage lines .028 in. (0.7 mm) wide.

2. Do all lettering .12 in. (3 mm) high with titles .24 in. (6 mm) high.
3. Reference designators are not shown; use the left-to-right and top-to-bottom labeling system, using coding as described in this chapter: R1, R2, R3 . . . , C1, C2. . .
4. Label horizontal components above and vertical components to the right.
5. Place connection dots as necessary.



© Cengage Learning 2012

**PROBLEM 20.41 Electronics schematic**

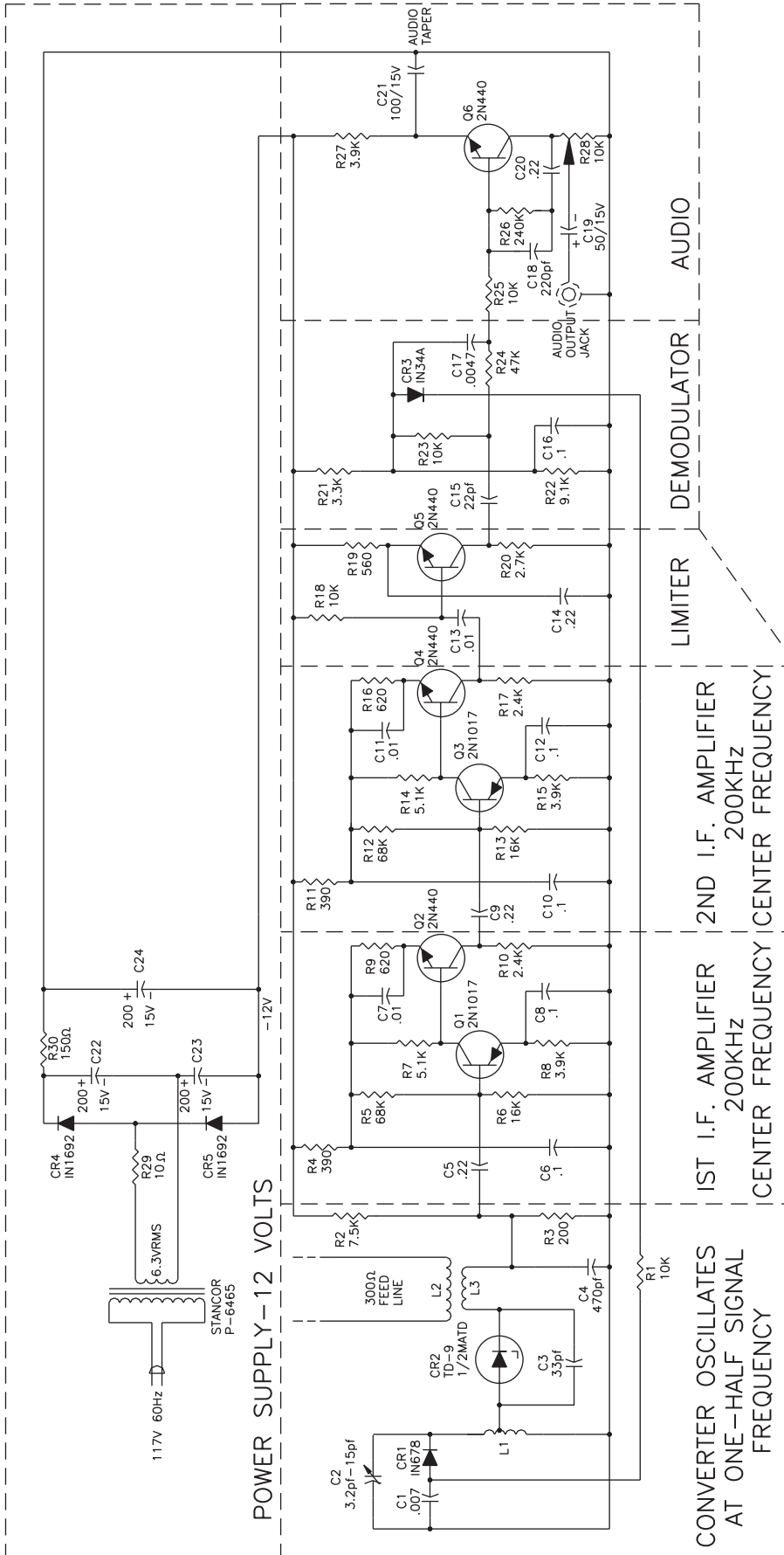


**NOTES:**

1. INTERPRET ELECTRICAL AND ELECTRONICS DIAGRAMS PER ANSI Y14.15.
2. UNLESS OTHERWISE SPECIFIED:  
 RESISTANCE VALUES ARE IN OHMS.  
 RESISTANCE TOLERANCE IS 5%.  
 RESISTORS ARE 1/4 WATT.  
 CAPACITANCE VALUES ARE IN MICROFARADS.  
 CAPACITANCE TOLERANCE IS 10%.  
 CAPACITOR VOLTAGE RATING IS 20V.  
 INDUCTANCE VALUES ARE IN MICROHENRIES.

© Cengage Learning 2012

PROBLEM 20.42 FM tuner schematic



FM TUNER

NOTES:

1. INTERPRET ELECTRICAL AND ELECTRONICS DIAGRAMS PER ANSI Y14.15.
2. INTERPRET REFERENCE DESIGNATIONS FOR ELECTRICAL AND ELECTRONICS PARTS AND EQUIPMENTS AS PER ANSI Y32.16.
3. INTERPRET GRAPHIC SYMBOLS FOR ELECTRICAL AND ELECTRONICS DIAGRAMS PER ANSI Y32.2.
4. ALL CAPACITORS ARE LISTED IN MICRO FARADS UNLESS NOTED.
5. IN3712 (TD-1) CAN BE USED IN PLACE OF TD-9. REDUCE 200 Ω BIAS RESISTOR TO 68 Ω AND ADJUST BIAS VOLTAGE TO 125 MILLIVOLTS BY CHANGING 7.5K RESISTOR TO APPROX. 2.2K.
6. L2-4 TURNS #18 3/8" I.D., APPROX. 1/2" LONG.
7. L3-4 TURNS #18 3/8" I.D., APPROX. 1/2" LONG.
8. (L2 & L3 COUPLED END TO END, SPACED APPROX. 1/8")
9. L1-8 1/2 TURNS #18 3/8" I.D. CENTER TAPPED, APPROX. 3/4" LONG.





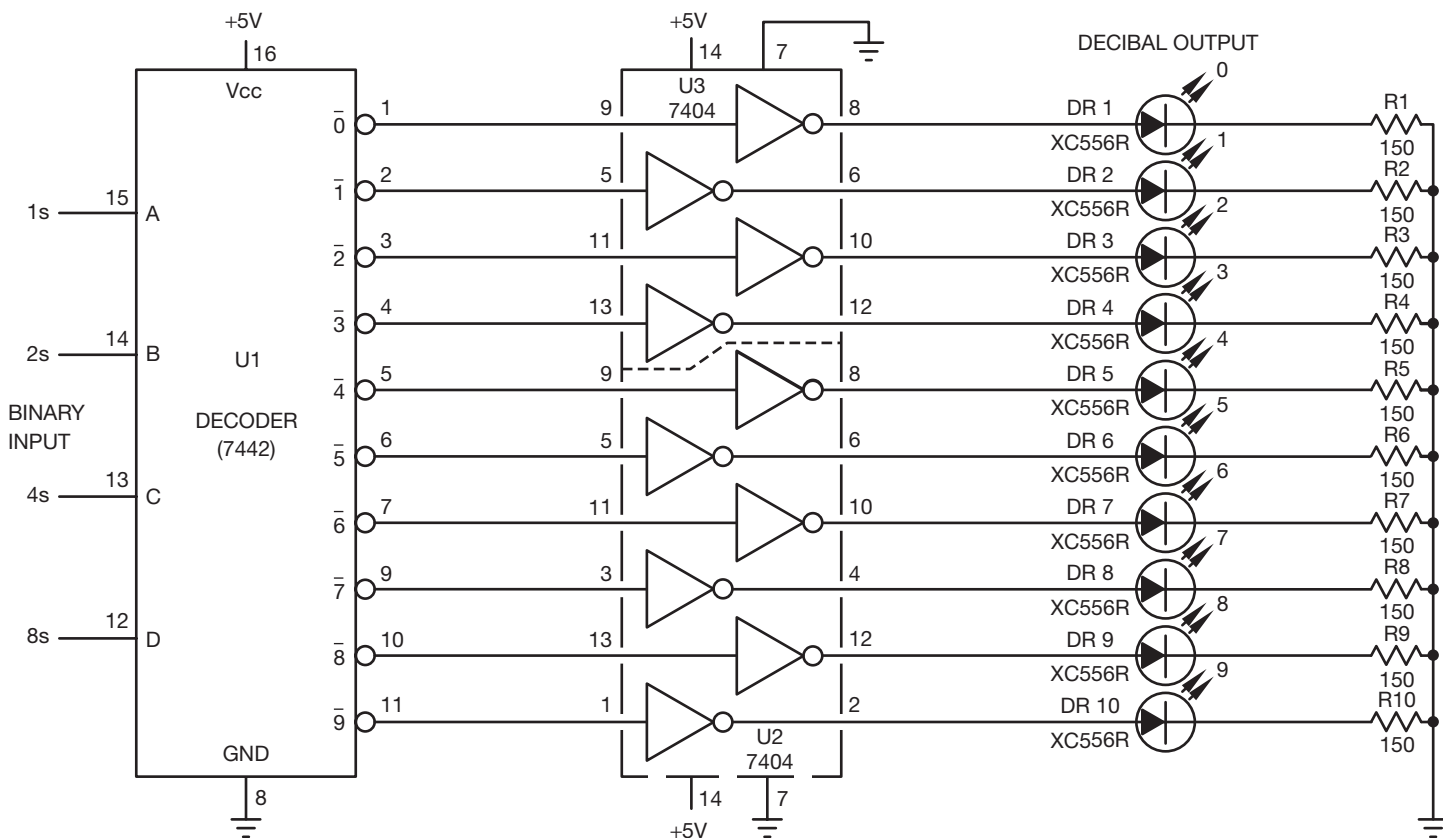
**PROBLEM 20.45 Schematic diagram**

Given the schematic engineering sketch, make a schematic diagram using 17 × 22 (A2 metric) size. There is no scale, and the drawing must be balanced, uncluttered, and easy to read. Use the following instructions unless otherwise specified by your instructor:

1. Draw the entire schematic with .020 in. (0.5 mm) wide lines and dashed stage lines .028 in. (0.7 mm) wide.

2. Do all lettering .12 in. (3 mm) high with titles .24 in. (6 mm) high.
3. Reference designators are not shown; use the left-to-right and top-to-bottom labeling system, using coding as described in this chapter: R1, R2, R3 . . . , C1, C2. . .
4. Label horizontal components above and vertical components to the right.
5. Place connection dots as necessary.

*Courtesy RCA Consumer Electronics*



**NOTES:**

1. REFERENCE DESIGNATORS ARE FOR REFERENCE ONLY AND MAY NOT APPEAR ON PART.
2. RESISTOR VALUES ARE IN DHMS.
3. FOR PWB/COMPONENT ASSEMBLY, SEE DWG. 100/01.
4. FOR PARTS, SEE SPL 100/02.
5. FOR PRINTED WIRING BOARD, SEE DWG. 100/03.

**Part 5: Problems 20.46 Through 20.52**



To access the Chapter 20 problems, go to the Student CD, select **Chapter Tests and Problems** and **Chapter 20**, and then open the problem of your choice or as assigned by your instructor. Solve the problems using the instructions provided on the CD, unless otherwise specified by your instructor.

**Math Problems**

**Part 6: Problems 20.53 Through 20.62**



To access the Chapter 20 problems, go to the Student CD, select **Chapter Tests and Problems** and **Chapter 20**, and then open the math problem of your choice or as assigned by your instructor. Solve the problems using the instructions provided on the CD, unless otherwise specified by your instructor.

# CHAPTER 21

## Industrial Process Piping

### LEARNING OBJECTIVES

After completing this chapter, you will:

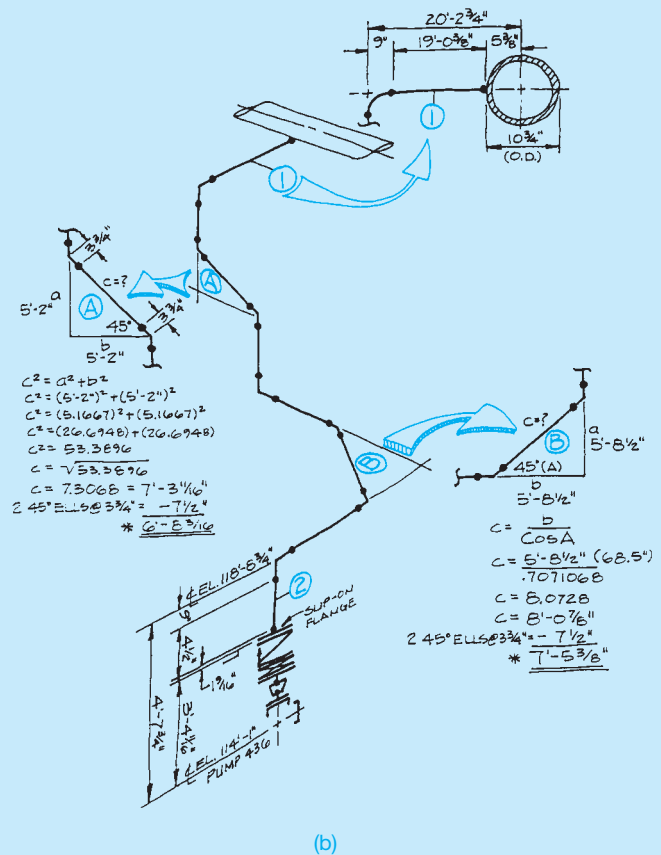
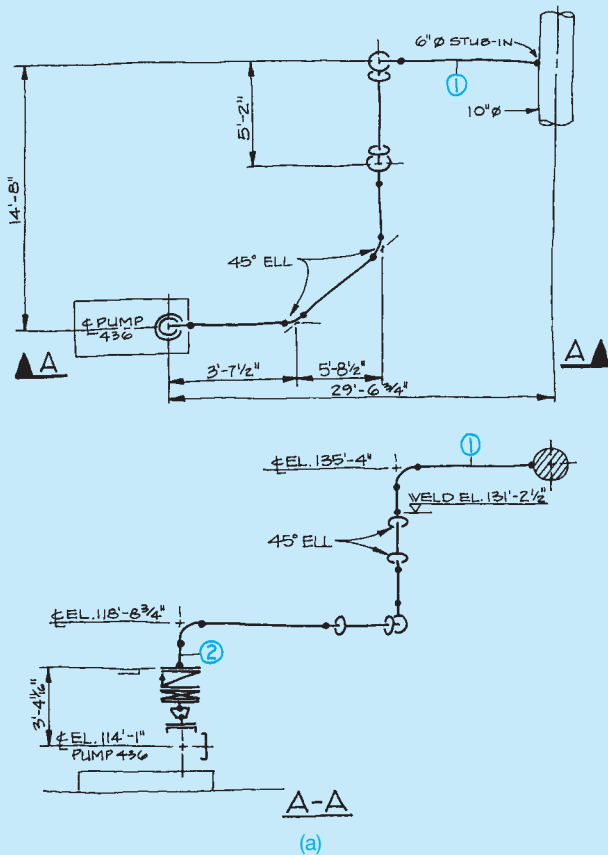
- Describe the different kinds of pipe and their uses.
- Define the methods of pipe connection and their applications.
- Identify pipe fittings and valves.

- Draw dimensioned, single-line, and double-line piping drawings using pipe fittings and valves.
- Construct piping isometric and spool drawings using piping plans and elevations.
- Given an engineering sketch of a piping arrangement, construct an isometric sketch, and calculate linear dimensions and straight lengths of pipe in angular pipe runs.

## THE ENGINEERING DESIGN APPLICATION

This problem requires that you use the engineering sketch shown in Figure 21.1 to create an isometric free-hand sketch then calculate the lengths of straight runs of

pipe shown as 1 and 2 in the sketch. Review Chapters 5, *Sketching Applications*, and 14, *Pictorial Drawings and Technical Illustrations*, if you are not familiar with isometric



**FIGURE 21.1** (a) This engineering sketch is used to construct an isometric sketch and to calculate the lengths of straight pipe in the angular offsets. (b) The solution to the engineering design application problem. © Cengage Learning 2012

sketching or drawing. Use the following instructions for this problem:

- STEP 1** Sketch the pipe run in isometric format.
- STEP 2** Calculate the lengths of the hypotenuse of triangles A and B (see Figure 21.1).
- STEP 3** Use the Pythagorean theorem or trigonometric formulae. The solution shows each method.

**STEP 4** Calculate overall lengths of straight runs of pipe, 1 and 2, including fittings.

**STEP 5** Add the fitting lengths and subtract from the overall length of the pipe run. Use Appendix W to find pipe-fitting and flange dimensions. All fittings and flanges are 150# rating. The pound (#) symbol is commonly used in these applications.

## INTRODUCTION

The term **pipng** can refer to any kind of pipe used in a wide range of applications. The word **plumbing** refers to the small-diameter pipes used in residential construction to carry water, gas, and wastes. Pipes for plumbing can be copper, steel, cast iron, and plastic. Large underground pipes that transport water and gas to homes and from public utilities and those that collect

the waste water that is taken to treatment plants are known as **civil piping** because of their **municipal** nature. The term *municipal* refers to a **municipality**, which is an administrative entity found in a city, town, or village. Steel, cast iron, and concrete are the principal materials used for civil piping.

Industrial plants involve a process that converts raw materials to finished products. Many industries use water, air, and steam to process the raw materials. **Process piping** is the piping used to transport fluids between storage tanks and processing equipment (see Figure 21.2).

Large-diameter pipes called **pipelines** carry crude oil, water, petroleum products, gases, coal slurries, and a variety of liquids hundreds of miles. This type of pipe is also known as **transportation piping** as shown in Figure 21.3.

## WHERE INDUSTRIAL PIPING IS USED

A network of piping lies beneath the ground in your neighborhood. Miles of pipes for water, sewers, storm drains, natural gas, and electrical power provide vital services (see Figure 21.4). Oil and gas pipelines provide the compounds that allow you to drive to work and school daily. The petrochemical plants



Courtesy BP

**FIGURE 21.2** Process piping transports fluids between storage tanks and processing equipment at this oil refinery.



Courtesy BP

**FIGURE 21.3** This pipeline is a form of transportation piping.



**FIGURE 21.4** Underground piping supplies natural gas for homes and industries. *Courtesy Pacific Gas & Electric*



Courtesy BP

**FIGURE 21.5** Petroleum refineries use miles of interwoven piping.



**FIGURE 21.6** Piping is a basic part of steam generation power plants.  
*Courtesy Washington Public Power Supply System*

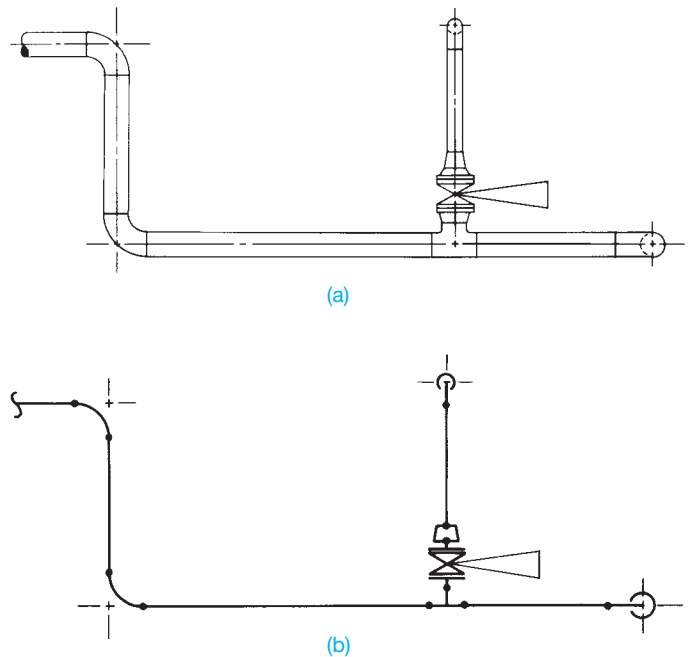
that process the crude oil into a tremendous variety of products employ thousands of miles of piping (see Figure 21.5).

The paper of the page you are reading was once a tree. The tree was chopped into chips, cooked into a pulpy stew, and pumped in pipes through a series of processes in a paper mill. The food you consume is processed with the aid of pipes filled with water, chemicals, and liquid mixtures. The beverages you drink are moved in pipes through the various stages of production. The electric wires that provide power are resting inside pipes called **electrical conduit**. The electric power inside the wires is produced at steam and nuclear power plants containing intricate networks of piping (see Figure 21.6).

## PIPE DRAFTING

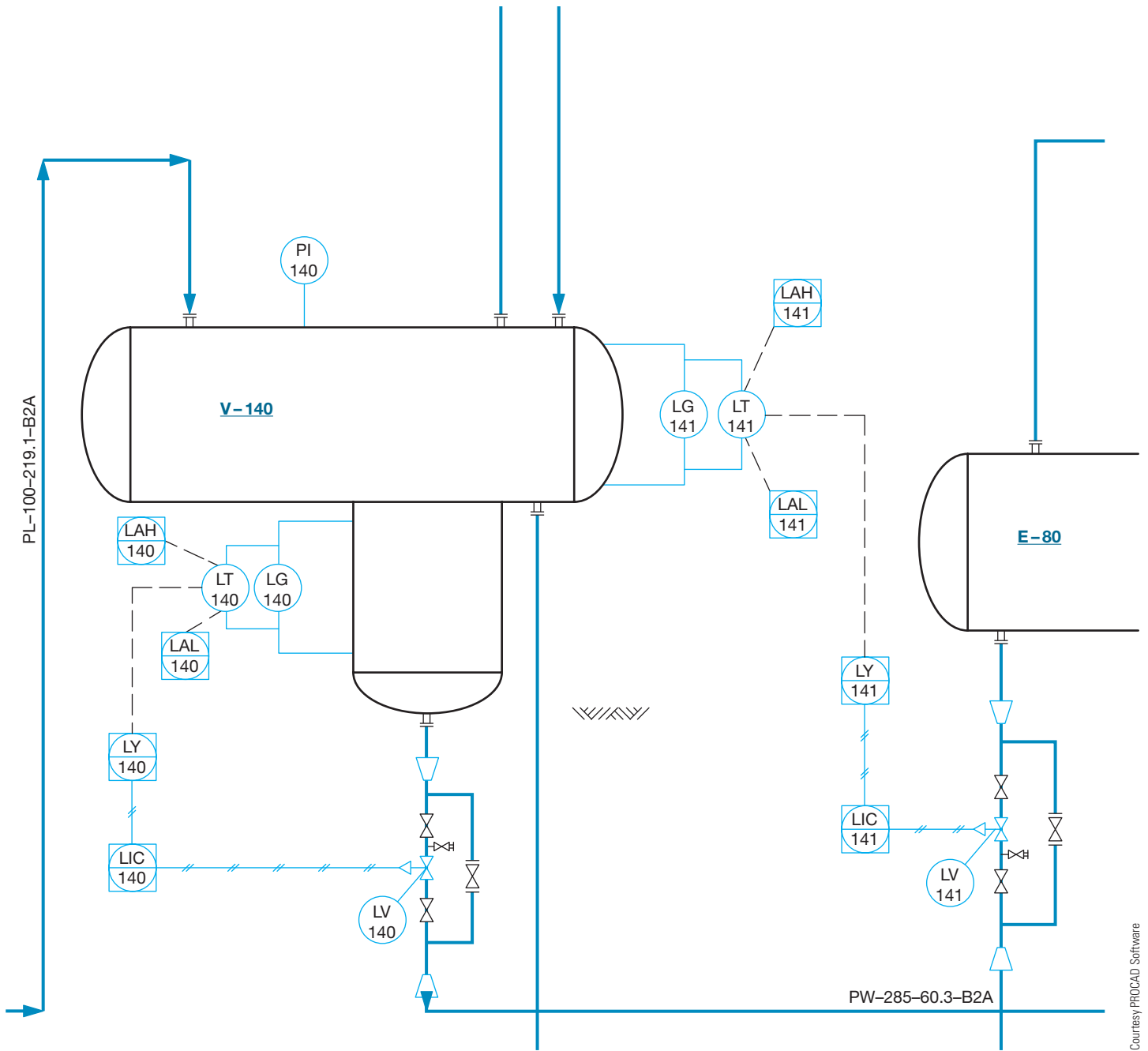
**Pipe drafting** is a specialized field that calls on the drafter's skill of visualization and the ability to see pipe and fittings in several planes, or depths, in an orthographic view. Pipe fittings must often be turned and rotated at angles. Visualization can be confusing for beginning pipe drafters and engineers. Therefore, the study of pictorial isometric and three-dimensional (3-D) drafting techniques is important. Pipe can be drawn in two forms: double line and single line as shown in Figure 21.7. The single-line method usually gives beginners the most visualization problems. The single-line method is discussed later in this chapter. The single-line method is not as common today as the double-line method. The principal area of learning is the area of pipe fittings and joining methods. A major portion of this chapter covers these areas. As you continue, your ability to visualize should be improved by taking additional time to study and draw pipe fittings.

Pipe drafting involves the creation of a variety of drawing types from maps such as site plans and mechanical drawings such as piping details. One of the easiest types of drawings to construct is the **process flow diagram (PFD)** shown in Figure 21.8. The PFD is a nonscale schematic diagram that illustrates the layout and composition of a system using symbols. A subset of PFD is the **process and instrumentation diagram (P&ID)**. P&ID drawings are also nonscale schematic diagrams, but they include more details about the instrumentation



**FIGURE 21.7** Pipe can be drawn using (a) double-line or (b) single-line representation. © Cengage Learning 2012



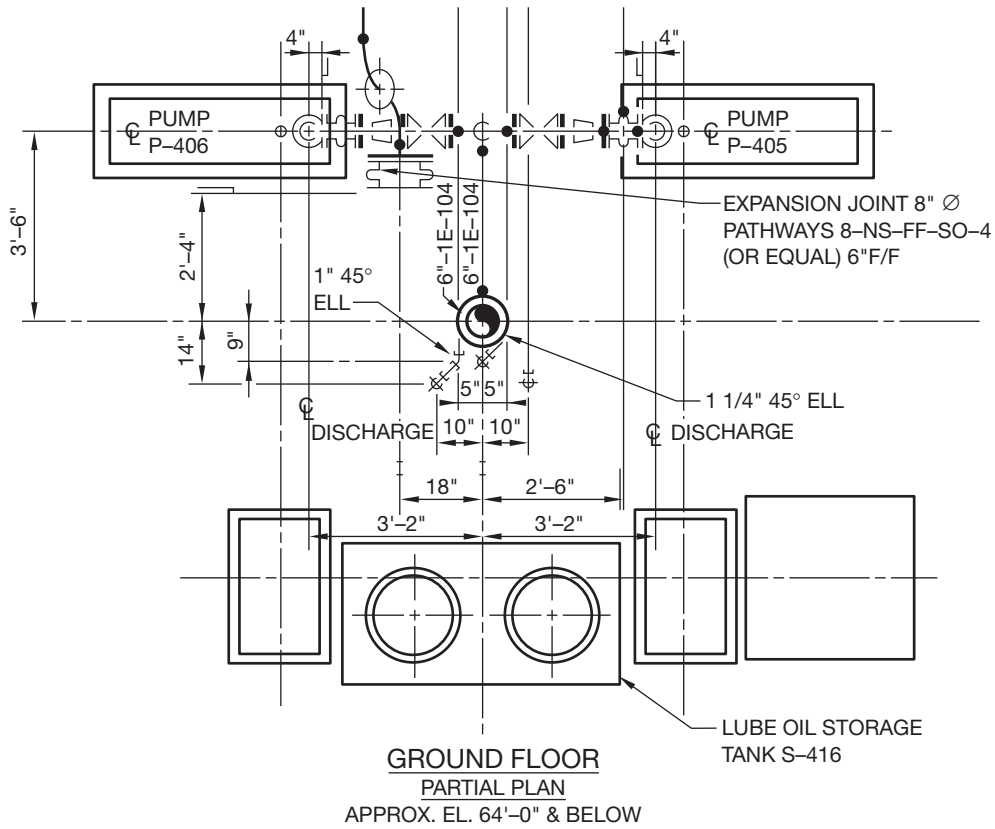


**FIGURE 21.9** This P&ID shows an entire control valve station, consisting of two isolating gate valves, a bypass ball valve, the drain, and the control valve instead of just the control valve that might be shown on a PFD. A P&ID uses a series of balloons, the type of controller attached to the valve, and how the signal is transmitted from the indicator or gage to the valve. The balloon symbol and the specific letters used inside indicate the control information. For example, PG represents a pressure gage, and a TIG represents a temperature indicator and gage.

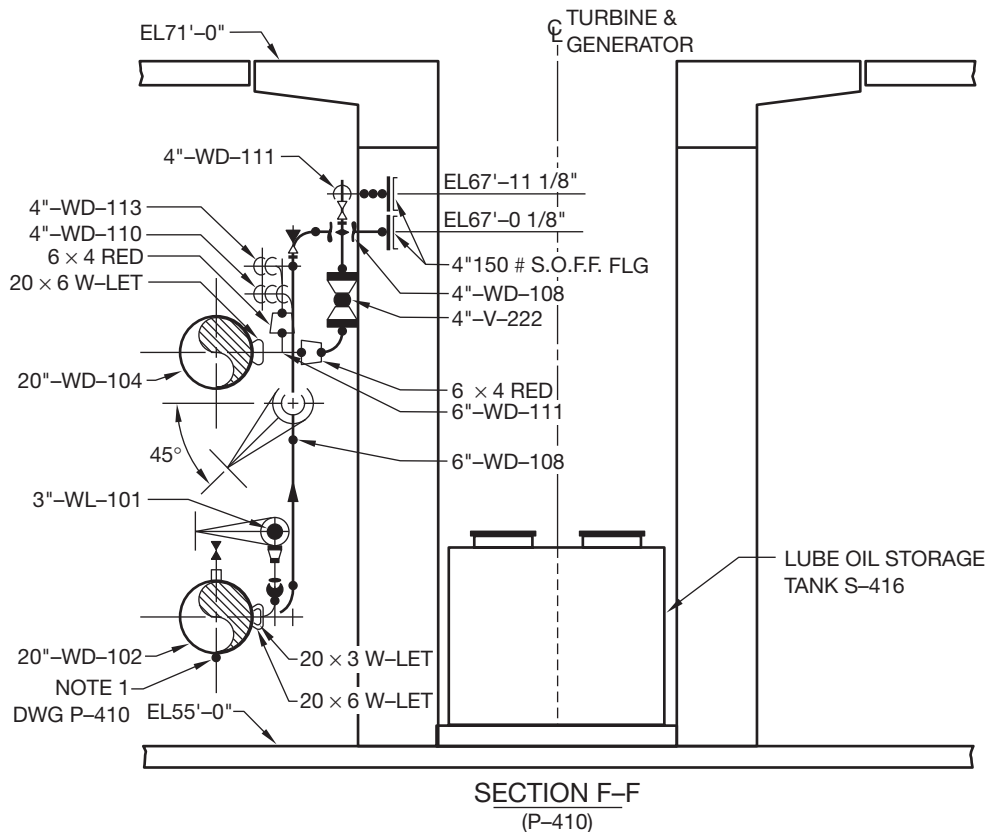
schematics to be used in the plant. For example, entire control valve stations might be shown, consisting of two isolating gate valves, a bypass ball valve, the drain, and the control valve instead of just the control valve that might be shown on a PFD. A P&ID uses a series of balloons to indicate the type of controller attached to the valve and to specify how the signal is transmitted from the indicator or gage to the valve. The balloon symbol and the specific letters used inside indicate the control information. For example, PG represents a pressure gage, and a TIG represents a temperature indicator and gage (see Figure 21.9).

## PIPE DRAWINGS

**Piping drawings** are also referred to as **general arrangement (GA) drawings**. A GA drawing is a scale drawing that provides plan, elevation, and section views with equipment, fittings, dimensions, and notes shown. Figures 21.10a–b show examples of plans and sections. The drafter uses flow diagrams; structural, mechanical, and instrumentation drawings; and vendor catalogs to construct plans and sections. Drawings can also be provided from other departments or other companies,



(a)

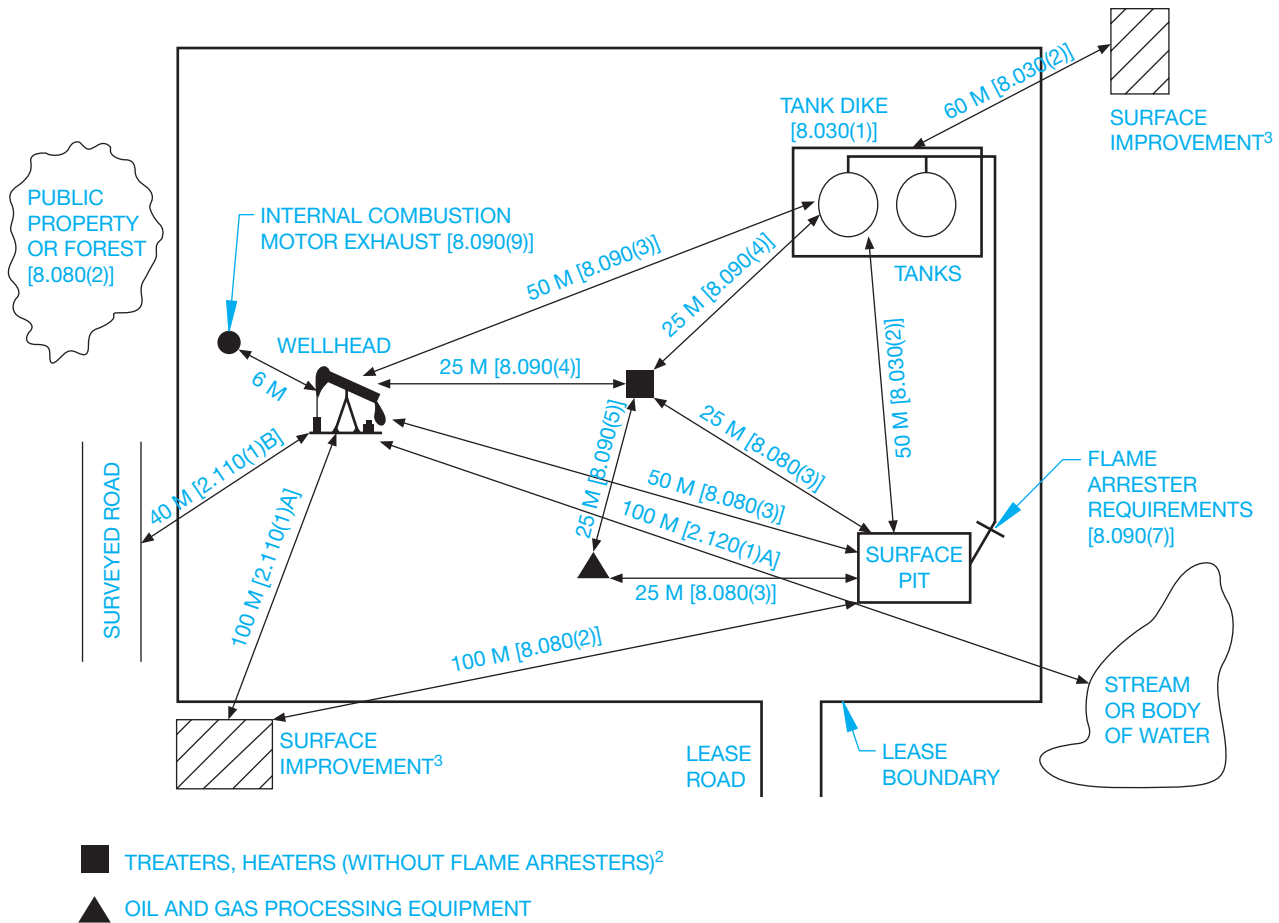


(b)

FIGURE 21.10 (a) The piping plan. (b) Section containing detailed piping information.

Courtesy Schuchart & Associates





1. THE SPADING REQUIREMENTS ILLUSTRATED HERE ARE AS SPECIFIED IN THE OIL AND GAS CONSERVATION REGULATIONS SECTIONS INDICATED WITH IN SQUARE BRACKET ALONGSIDE OR UNDERNEATH EACH MEASUREMENT. NOTE THAT THERE IS NO SMOKING WITHIN 25 M OF A WELL, SEPARATOR, OIL STORAGE TANK, OR OTHER UNPROTECTED SOURCE OF IGNITABLE VAPOUR [SECTION 8.120(1)].
2. TREATERS AND HEATERS WITHOUT FLAME ARRESTERS ARE NOT TO BE HOUSED IN THE SAME BUILDING UNLESS AIR INTAKES, FLUES, VENTS, IGNITABLE VAPOURS, ETC., ARE VENTED OUTSIDE ABOVE ROOF LEVEL AND THE BUILDING IS CROSS-VENTILATED [8.090(6)A,B,C]. TREATERS AND HEATERS WITH FLAME ARRESTERS MUST ALSO BE 25 M FROM A WALL, OIL STORAGE TANK, OR OTHER SOURCE OF LIGHTABLE VAPOUR [8.090(4)].
3. "SURFACE IMPROVEMENT" MEANS A RAILWAY, PIPELINE OR OTHER RIGHT-OF-WAY, ROAD ALLOWANCE, SURVEYED ROADWAY, DWELLING, INDUSTRIAL PLANT, AIRCRAFT RUNWAY OR TAXIWAY, BUILDING USED FOR MILITARY PURPOSE, PERMANENT FARM BUILDING, SCHOOL OR CHURCH [1.020(1)28].

**FIGURE 21.11** Government regulations control the required distances between different process vessels, clearances from roads, and required space for personnel. Process vessels are the storage tanks found in the installation. An example of this is the Alberta Energy Utility Board in Canada, which regulates the oil and gas industry in the province.

such as completed and detailed equipment drawings, or civil drawings showing the details of the buildings where the piping will be installed. Government regulations also control the required distances between different **process vessels**, clearances from roads, and required space for personnel. Process vessels are the storage tanks found in a piping installation. An example of this is from the Alberta Energy Utility Board in Canada, which regulates the oil and gas industry in the province (see Figure 21.11).

The **piping isometric** is a pictorial drawing that illustrates pipe runs in 3-D form (see Figure 21.12). Information used in the piping isometric drawing is obtained from the piping

drawings. Your ability to view piping runs in three planes is important when working with piping isometrics. Some pipe drawings are done in isometric form because lines can be measured and fits and clearances can be checked. Three-dimensional modeling software programs used for industrial pipe design have the ability to generate isometrics automatically.

Pipe fitters and welders use a piping **spool drawing** to construct subassemblies of pipe and fittings. A spool drawing is usually two-dimensional (2-D) and shows all of the pipe and fittings needed to assemble a segment of piping. Spools are normally nonscale drawings that show all dimensions needed for assembly. Figure 21.13 shows a typical spool drawing.

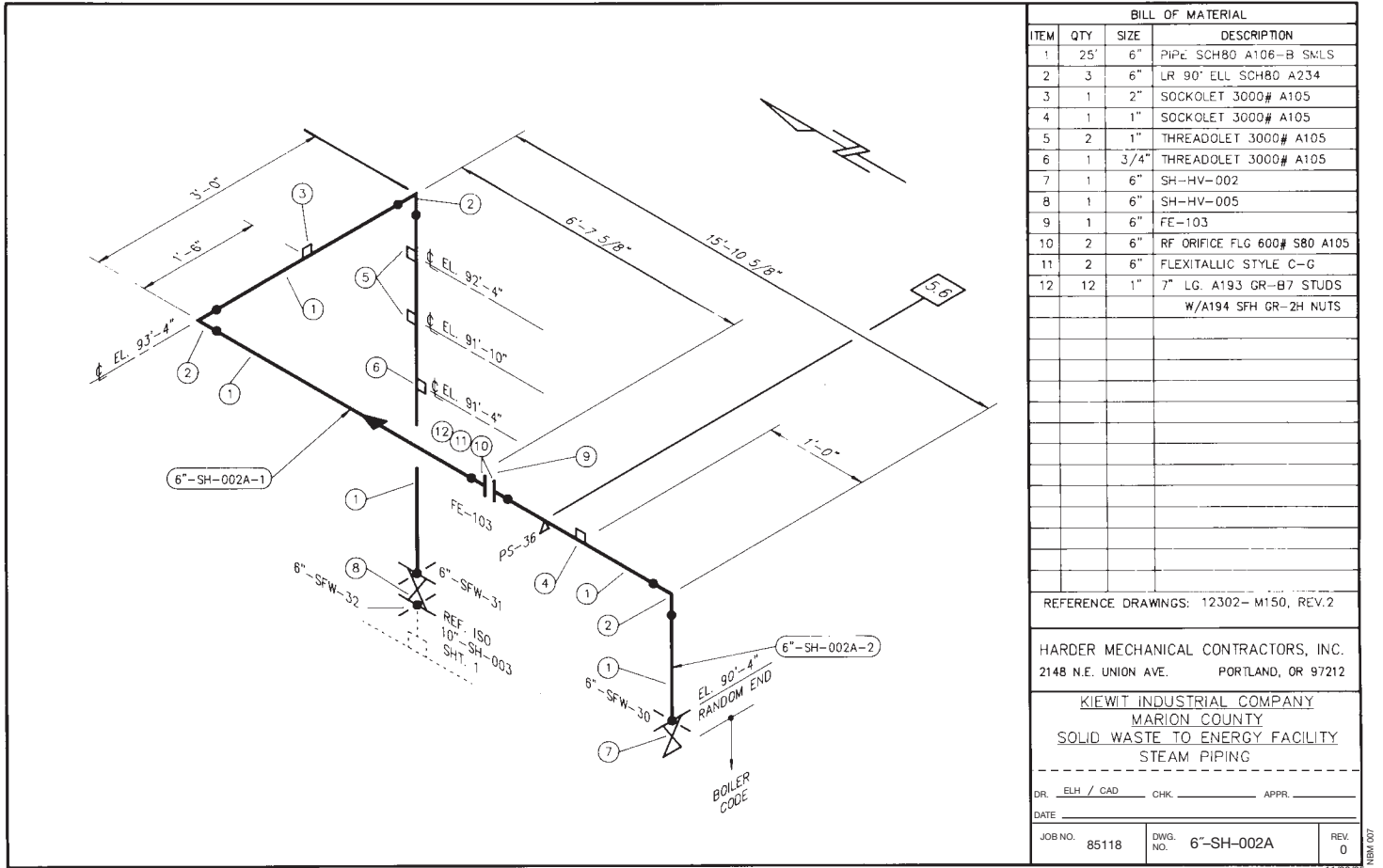


FIGURE 21.12 The piping isometric shows a pictorial view of a single run of pipe. Courtesy Harder Mechanical Contractors, Inc.

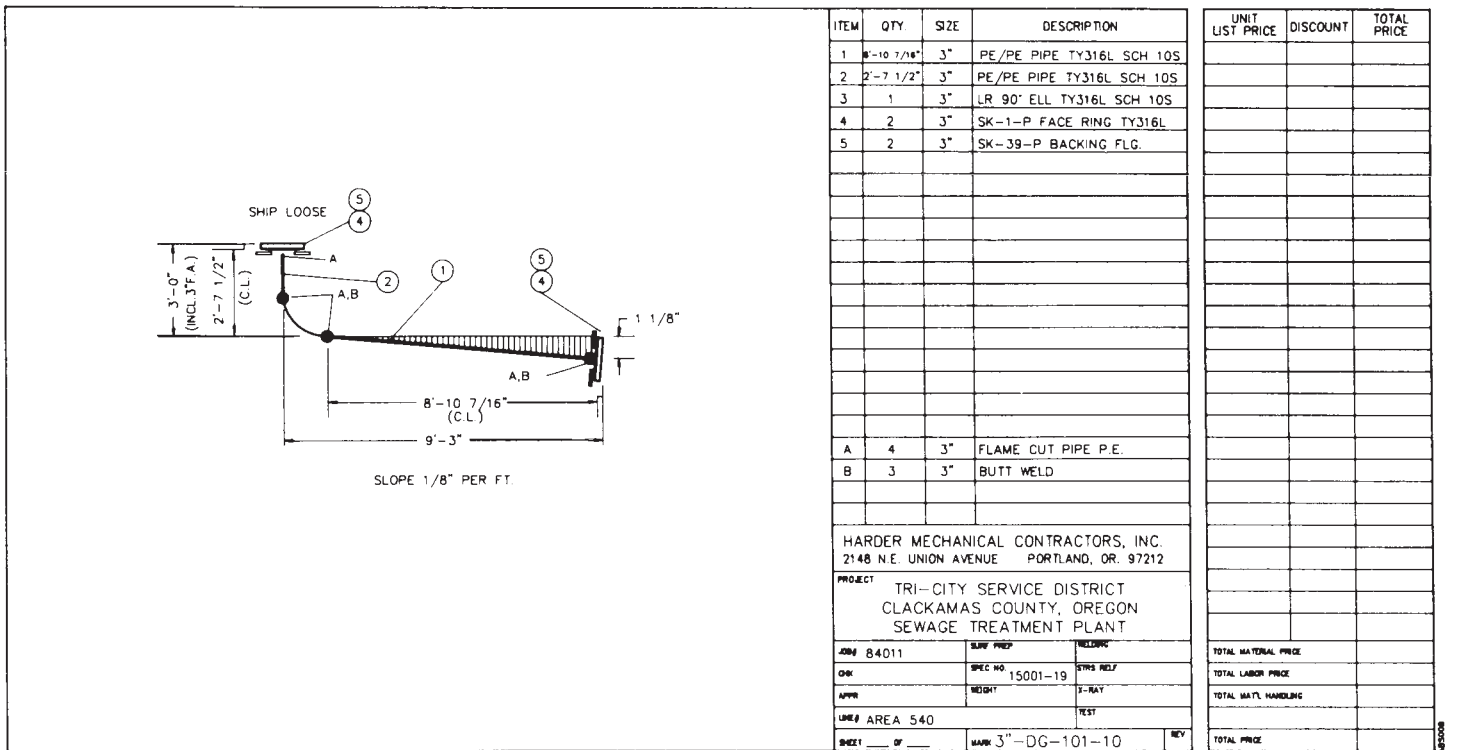


FIGURE 21.13 A piping spool drawing is a subassembly of pipe and fittings. Courtesy Harder Mechanical Contractors, Inc.

## TYPES OF PIPE

When an engineer or designer decides to use a specific type of pipe, the decision is based on a number of considerations. The main pipe selection considerations include temperature, pressure, and corrosion. Safety and cost are also important factors. Finally, any decision must comply with the project specifications and local and national codes.

## STANDARDS

ASME Figure 21.14 lists the ASME Codes and Standards—Piping and Pipelines Collection specifications that apply to pipes and fittings.

### THE ASME CODES AND STANDARDS – PIPING AND PIPELINES COLLECTION

The ASME Codes and Standards – Piping and Pipelines Collection – contains the following documents:

A13.1	<b>Scheme for the Identification of Piping Systems</b> This Standard provides general guidance on the marking of pipes and piping systems with respect to their contents and potential hazards.	B31.11	<b>Slurry Transportation Piping Systems</b> This Code prescribes requirements for the design, materials, construction, assembly, inspection, testing, operation, and maintenance of piping transporting aqueous slurries of non hazardous materials, such as coal, mineral ores, concentrates, and other solid materials.
B31.1	<b>Power Piping</b> This Code prescribes minimum requirements for the design, materials, fabrication, erection, test, and inspection of power and auxiliary service piping systems for industrial plants.	B31G	<b>Manual for Determining the Remaining Strength of Corroded Pipelines</b> This Manual provides guidance to the designer and owner/operator for in-service acceptance of corroded pipelines constructed to the ASME B31.4, B31.8, and B31.11.
B31.2	<b>Fuel Gas Piping</b> This Code covers the design, fabrication, installation, and the testing of piping systems for fuel gases used in buildings and between buildings from the meter outlet to the first pressure valve.	B31Q	<b>Pipeline Personnel Qualification</b> This Standard sets requirements for effective pipeline personnel qualification programs addressing covered tasks that impact pipeline safety and management of qualifications of pipeline personnel.
B31.3	<b>Process Piping</b> This Code contains requirements for piping typically found in petroleum refineries; chemical, pharmaceutical, textile, paper, semiconductor and cryogenic plants; and related processing plants.	B36.10M	<b>Welded and Seamless Wrought Steel Pipe</b> This Standard provides dimensions of welded and seamless wrought steel pipe for high or low temperatures and pressures applications.
B31.4	<b>Pipeline Transportation Systems for Liquid Hydrocarbons and Other Liquids</b> This Code contains requirements for piping transporting crude oil, natural gas liquids, liquefied petroleum products and other liquids between natural gas plants, refineries, and other facilities.	B36.19M	<b>Stainless Steel Pipe</b> This Standard provides dimensions of welded and seamless wrought stainless steel pipe for high or low temperature and pressure applications.
B31.5	<b>Refrigeration Piping and Heat Transfer Components</b> This Code prescribes requirements for the materials, design, fabrication, assembly, erection, test and inspection of refrigerant, heat transfer components, and secondary coolant piping for temperatures as low as $-320^{\circ}\text{F}$ ( $-196^{\circ}\text{C}$ ).	BPE	<b>Bioprocessing Equipment</b> The ASME BPE Standard standardizes specifications for the design, manufacture, installation, inspection, and acceptance of equipment used in the pharmaceutical and biologic products industries.
B31.8	<b>Gas Transmission and Distribution Piping Systems</b> This Code covers the safety aspects of operation and maintenance of gas transmission and distribution systems, gas pipelines, gas compressor stations, gas metering, and other similar equipment.	PCC-2	<b>Repair of Pressure Equipment and Piping</b> This Standard provides post construction repair techniques for metallic pressure equipment and piping. Seventeen articles cover repair methods and techniques that include the use of welding, brazing, soldering, or other methods involving metal deposit; mechanical repairs, with or without sealant; and repairs using nonmetallic means, such as nonmetallic liners and wraps, and bonding (e.g., joining by epoxy), including bonding of metallic components.
B31.8S	<b>Managing System Integrity of Gas Pipelines</b> This Standard provides the pipeline operator with the information necessary to develop and implement an effective integrity management program utilizing proven industry practices and processes.	PTC 25	<b>Pressure Relief Devices</b> This Code provides standards for conducting and reporting tests on reclosing and nonreclosing pressure relief devices in boilers, pressure vessels, and related piping equipment.
B31.9	<b>Building Services Piping</b> This Code has rules for piping systems for building services in industrial, institutional, commercial and public buildings and multi-unit residences either in the building or within property limits.		

FIGURE 21.14 ASME specification for pipe, fittings, valves, and pipe hangers. © Cengage Learning 2012



## ASTM International— Standards for Steel Pipes, Tubes, and Fittings

**ASTM** For a list of American Society for Testing Materials (ASTM) Standards for Steel Pipes, Tubes, and Fittings documents, go to the Student CD, select **Supplemental Material**, select **Chapter 21**, and then select **ASTM International—Standards for Steel Pipes, Tubes, and Fittings**. For more information or to order standards, go to the ASTM Web site at [www.astm.org](http://www.astm.org).

## Cast Iron Pipe

The most common types of pipe used for commercial and industrial applications are steel and **cast iron**.

### STANDARDS

**AWWA** The American Water Works Association (AWWA) ([www.awwa.org](http://www.awwa.org)) specifies cast iron for underground water lines. Cast iron pipe is corrosion resistant and has a heavy wall construction. It is good for use under pavement because its long life reduces the need to dig up the pavement because of frequent leaks. Cast iron is used extensively for water, gas, and sewage piping.

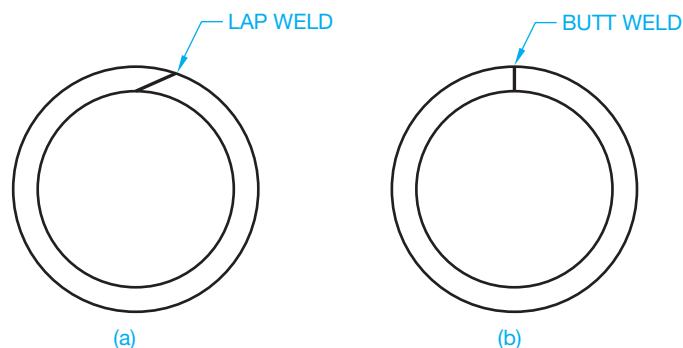
## Steel Pipe

Carbon steel pipe is the preferred above-ground pipe used in industry today. It is strong, relatively durable, and can be welded and machined. It is also not as expensive as other materials. In conditions of high temperature, carbon steel pipe tends to lose strength. Stainless steel and other alloys are used in high-temperature applications.

Several processes can be used to manufacture steel pipe. Forged pipe is formed to a special **outside diameter (OD)**, which is usually 1 in. (25 mm) greater than the finished pipe. The forged pipe is then bored to the required **inside diameter (ID)**. **Seamless pipe** is created by piercing a solid **billet** and rolling the resulting cylinder to the required diameter. A billet is a section of steel used for rolling into bars, pipe, and rods. **Welded pipe** is formed from plate steel. The edges are welded together in a **lap weld** or a **butt weld** (see Figure 21.15).

## Steel Tubing

**Tubing** is small-diameter pipe and is often flexible, thus eliminating the need for many common fittings. Tubing is specified by its outside diameter and wall thickness. Tubing uses include external heating applications, boilers, super heaters, and hydraulic lines in the automotive, equipment, and aircraft industries.



**FIGURE 21.15** (a) Lap-welded steel pipe. (b) Butt-welded steel pipe.

© Cengage Learning 2012

## Copper and Copper Alloy Pipe

**Copper pipe** and copper alloys can be manufactured by the hot piercing and rolling process or by an extrusion method. Copper pipe is corrosion resistant and has good heat-transfer properties but has a low melting point and is expensive. Copper pipe is good for instrument lines and food processing, although stainless steel is used more frequently in these applications. Copper pipe is also used in residential water lines, but it is being replaced by advanced plastic products.

**Copper tubing** is softer and more pliable than rigid copper and brass pipe and is used for steam, air, and oil piping. Copper tubing is also used extensively for **steam tracing**. Steam tracing is the small-diameter pipe that is attached to larger pipes to protect them from freezing or to keep the fluids inside the pipe warm. Steam tracing is also used to keep liquids from solidifying or condensing in a steam-carrying heater next to or twisted around a process-fluid or instrument-air line. The outside diameter of copper tubing is the same as its **nominal pipe size (NPS)**. For example, a 3/4" tube has an outside diameter of 3/4".

## Plastic Pipe

**Thermoplastic pipe** is plastic pipe material that can be heated and formed by pressure. Upon reheating, the shape can be changed. This first type of plastic pipe was **polyvinyl chloride (PVC)**. PVC piping is now used for acids, salt solutions, alcohols, crude oil, and a variety of highly corrosive chemicals. Appendix Y lists PVC pipe specifications.

**Polyethylene (PE) pipe** can handle temperatures up to 150°F (65.5°C) and is suitable for water and vent piping of corrosive and acidic gases. PE piping is used as conduit for electrical and phone lines, water lines, farm sprinkler systems, saltwater disposal, and chemical waste lines. Other forms of plastic piping include **acrylonitrile-butadienestyrene (ABS)**, which is popular for sewage piping, **cellulose-acetatebutyrate (CAB)**, and **fiberglass-reinforced pipe (FRP)**.

## Concrete Pipe

Concrete pipe is used mainly for subsoil drainage for such applications as storm sewers and sanitary sewers. Concrete pipes can be reinforced or unreinforced, and they are used for reinforced pressure pipe, prestressed cylinder pressure pipe, and culvert pipe. Diameters larger than 15 in. (380 mm) are usually reinforced. Types of concrete pipe joints include O-ring gaskets, profile gaskets, and mortar and mastic joints. O-ring gaskets are used on all sanitary and some storm-reinforced concrete pipe where leak-resistant joints are required. Profile gaskets are used on storm water culverts and reinforced concrete pipe storm and sanitary sewers. Mortar or mastic joints are used for storm sewers, culverts, and horizontal elliptical reinforced concrete pipe.

## Clay Pipe

Clay pipe is formed under high pressure from **fire clay**, **shale**, or a combination of fire clay and shale. Fire clay is a specific kind of clay used in the manufacture of ceramics, especially fire brick. Shale is a fine-grained rock composed of flakes of clay minerals and tiny fragments of other minerals, such as quartz. Clay pipe is dried and then fired at 2100°F (1149°C). The process fuses the clay particles together to form a solid, durable pipe. Clay pipe is one of the most corrosion-proof pipes available for use in sanitary and industrial sewers, and it can carry any known chemical waste except hydrofluoric acid.

## Glass Pipe

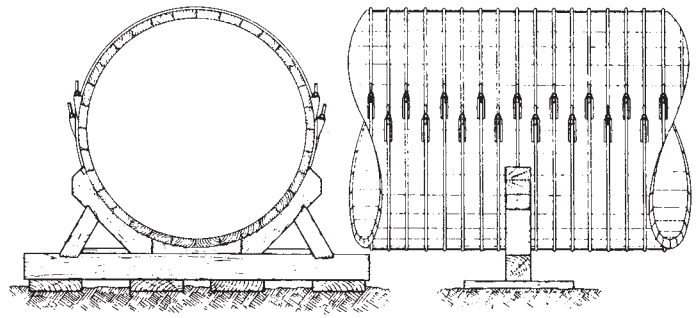
The chemical resistance, transparency, and cleanliness of glass make it popular for applications in the chemical, food and beverage, and pharmaceutical industries. Glass pipe can withstand temperatures as high as 450°F (232°C).

## Wood Pipe

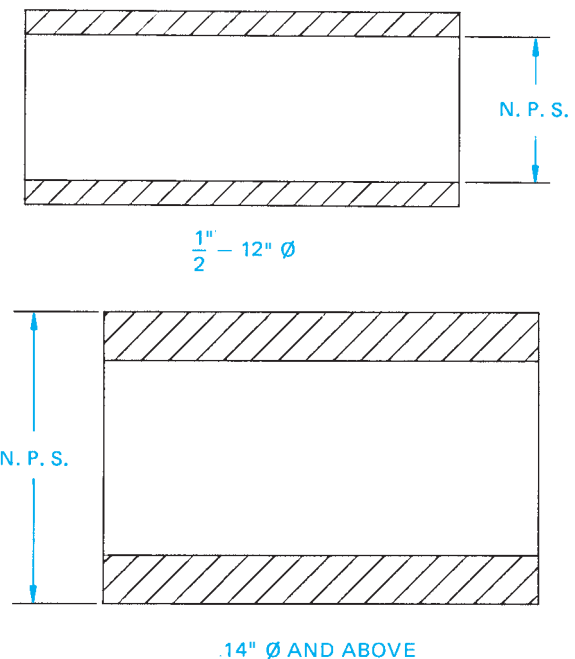
**Continuous stave wood pipe** was once used in areas such as in the Pacific Northwest because of the abundance of redwood and Douglas fir. Wood pipe is no longer used for new installations, but a few can be found in existing old installations. Tongue and groove **staves** are milled to exact radii for the specific diameter of pipe. Staves are narrow strips of wood. Staves are fitted together then strapped with wire, flat steel bands, or steel rod threaded on the ends and tightened with bolts. (See Figure 21.16.) The wood used for this pipe is rot resistant, especially when water under constant pressure is flowing through the pipe. Wood stave pipe is used almost exclusively for transporting water and is available in sizes from 10 in. to 16 ft. in diameter.

## PIPE SIZES AND WALL THICKNESS

Pipe is available in sizes from 1/8" to 44" (3–1100 mm) in diameter. Sizes greater than this can be ordered but are not normally stocked by suppliers. The typical range of commonly stocked



**FIGURE 21.16** Front and side views of a wood stave pipe resting in its foundation cradle. Courtesy National Tank & Pipe Co.



**FIGURE 21.17** Measuring nominal pipe size (NPS).

pipe is from 1/2" to 24" (12–600 mm). These sizes are most often used in process piping. Sizes from 1/8" to 1/2" (3–12 mm) are used for instrument lines and service piping.

Pipe is specified by its nominal pipe size. The NPS for pipe 1/8" to 12" (3–300 mm) is the inside diameter, and pipe 14" (350 mm) and above uses the outside diameter as the NPS (see Figure 21.17). To determine the actual inside diameter of a pipe, double the wall thickness and subtract that number from the outside diameter.

## STANDARDS

**ANSI/ASME** The wall thickness of pipe varies in relation to the size and weight of the pipe. The ANSI/ASME B36.10M, *Welded and Seamless Wrought Steel Pipe*, document provides specifications for wall thickness using **schedule (SCH)** numbers. SCH numbers range from 10 to 160, the higher number representing the thicker wall.

The ANSI schedule numbers incorporate the classifications of the ASTM and ASME, which use the designations of standard (STD), extra strong (XS), and double extra strong (XXS). These three classifications are drawn from manufacturers' dimensions. The STD wall thickness compares to SCH 40, XS to SCH 80, and XXS has no comparable schedule number, because it is a thicker wall than SCH 160.

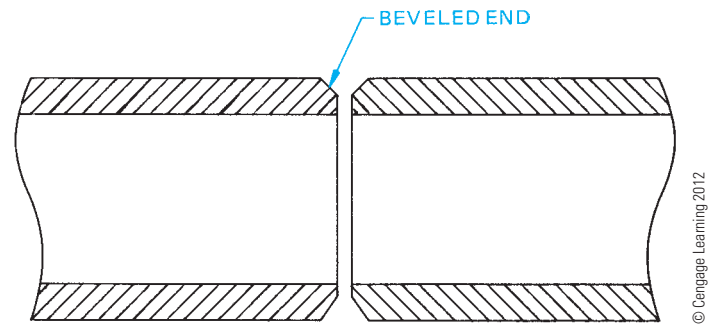


FIGURE 21.19 Bevel-end pipe is used for butt-welded pipe connections.

## PIPE CONNECTION METHODS

There are various pipe connection methods used in the industrial piping industry. It is important for you to become familiar with these connection methods.

### Butt-Welded Connection

Butt welding is the most common method of joining pipes used in industry today. Butt welding is used on steel pipe 2 in. (50 mm) diameter and more to create permanent systems. Butt-welded pipe and fittings provide a uniform wall thickness throughout the system. The smooth inside surface creates gradual direction changes, thus generating little turbulence in the product flowing inside the pipe. One weld is required around the circumference of the pipe to join two pieces of pipe. A common weld gap is 1/8" (3 mm). The number of welds can vary depending on the NPS.

Figure 21.18 shows a cross section of a butt weld. The butt weld is strong, leak proof, and relatively maintenance free. Pipe joined in this manner is self-contained, withstands high temperature and pressure, is easy to insulate, and requires less space for construction and hanging than do other methods. Pipe and fittings joined by butt welding are prepared with a beveled end (BE). A beveled end preparation provides space for the welding operation (see Figure 21.19).

### Socket-Welded Connection

The **socket-welded** connection shown in Figure 21.20 is used on pipe 2 in. (50 mm) diameter and smaller. The socket weld forms a reliable, leak-proof connection. The pipe has **plain end (PE)** preparation and slips into the fitting. One exterior weld

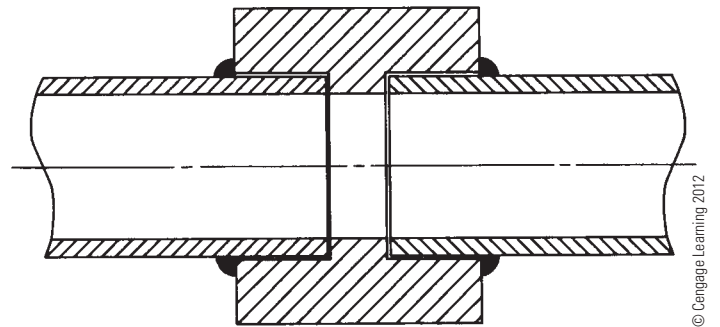


FIGURE 21.20 The socket-welded connection forms a leak-proof joint.

is required, thus no weld material protrudes into the pipe. Because the pipe is slipped inside the fitting, the connection is self-aligning. Socket welding small-diameter pipe is less expensive than other welded systems.

### Screwed Connection

Screwed connections are used on steel, malleable iron, cast iron, and cast brass pipe less than 2 1/2" (60 mm) diameter. A screwed connection is the least leak proof of the pipe-joining methods and is used where the temperature and pressure are low, such as in water lines or drain lines. The end preparation for screwed pipe is called **threaded and coupled (T&C)** because a coupling is usually supplied with a straight length of pipe. American standard pipe threads are the most common. The tightest fit is achieved by using fittings with straight threads and pipe with tapered threads. Pipe-sealing compounds and Teflon tape aid in producing a tighter fit. Figure 21.21 shows a typical coupling and pipe screwed connection.

### Flanged Connection

The **flanged** method of connecting pipes uses a fitting called a **flange**. The flange has an outside diameter greater than the pipe and contains several bolt holes. Flanges are welded to the ends of pipe and then sections of pipe can be bolted together

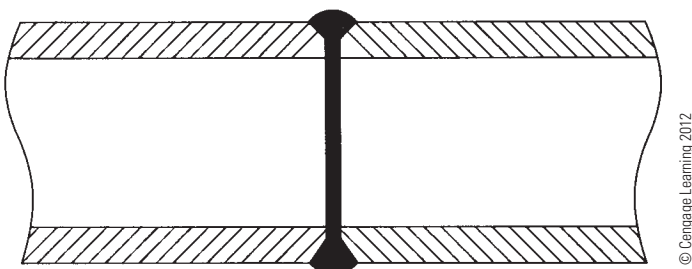


FIGURE 21.18 Cross section of a butt-welded pipe connection.

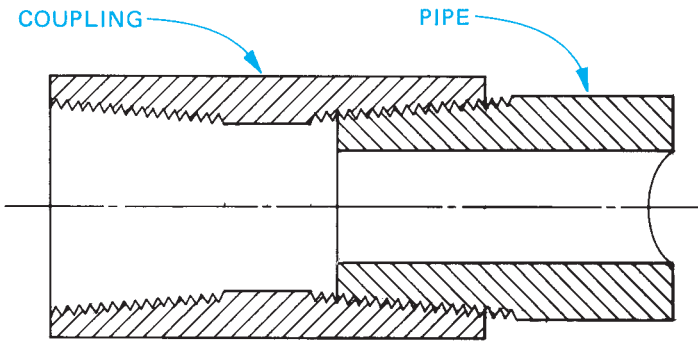


FIGURE 21.21 Cross section of a screwed connection. © Cengage Learning 2012

as shown in Figure 21.22. Most flanges are forged steel, cast steel, or iron. Flanged pipe is easily assembled and disassembled but is considerably heavier than butt-welded pipe. Flanged pipe occupies more space and is more expensive to support or hang.

Two steel flanges bolted together do not form a tight fit. There must be sealing material called a **gasket** placed between the two flange faces. The gasket can be a soft or semimetallic material. When the bolts are tightened, the gasket squeezes until it presses into the machining grooves of the flange faces to form a seal. **Soft gaskets** can be cork, rubber, asbestos, or a combination of materials. Semimetallic gaskets contain metal and soft material. The soft material provides resilience and gives a tight seal while the metal helps to retain the gasket in place against high pressure and temperature. Gaskets are

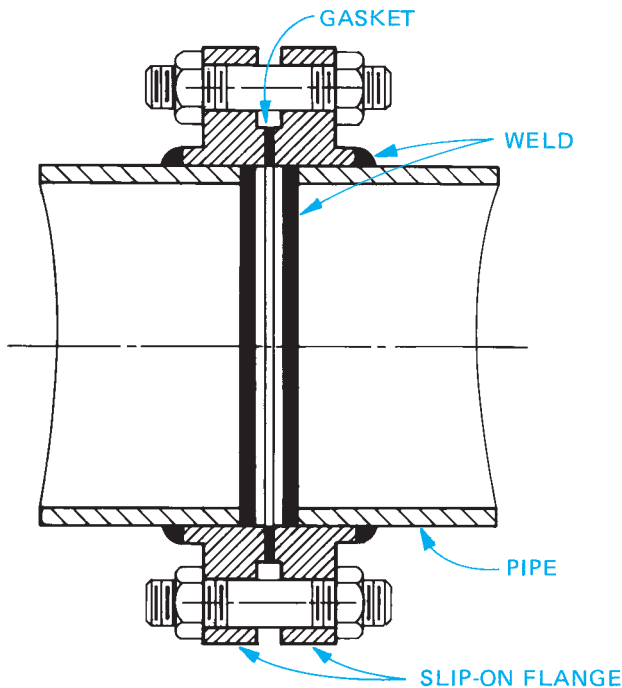


FIGURE 21.22 Cross section of a typical flanged connection.

chosen from a wide range of materials that resist deterioration caused by high temperatures and that are not chemically affected by the fluids in the pipe.

## Soldered Connection

Copper and brass water tubes are most often joined by **soldered** connections. **Solder** is an alloy of tin and lead. A soldered connection is created by heating solder until it melts into the joint and hardens upon cooling. Rigid and soft pipe can be soldered. Domestic water systems in which temperatures and pressures are low can use soldered connections. However, advanced plastic products are rapidly replacing the use of copper pipe with soldered connections, because of the lead found in solder and the other advantages of plastics.

## Bell (Hub) and Spigot Connection

Underground sewage, water, and gas lines are common applications of the **bell and spigot** connection method (see Figure 21.23). Cast iron pipe is used where pressures and loads are low. There are many variations of the bell and spigot method, but they all use a sealer to reduce leaking. The most common sealer is lead and **oakum**, although cement is used in certain situations. Oakum is a fibrous sealer.

## Mechanical Joint Connection

The **mechanical joint** is a modification of the bell and spigot connection in which flanges and bolts are used with gaskets, packing rings, or grooved pipe ends to provide a seal. Some mechanical joints allow for angular deflection and lateral expansion of the pipe. This type of connection is used in low-pressure applications and where vibration can be excessive. Figure 21.24 shows a mechanical joint.

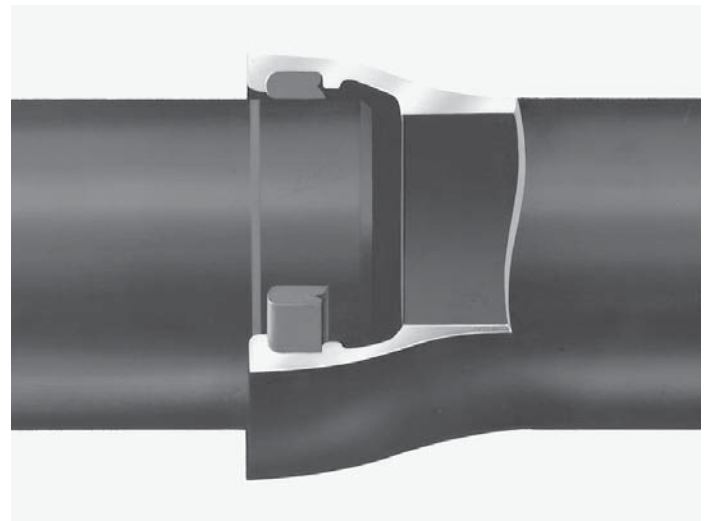
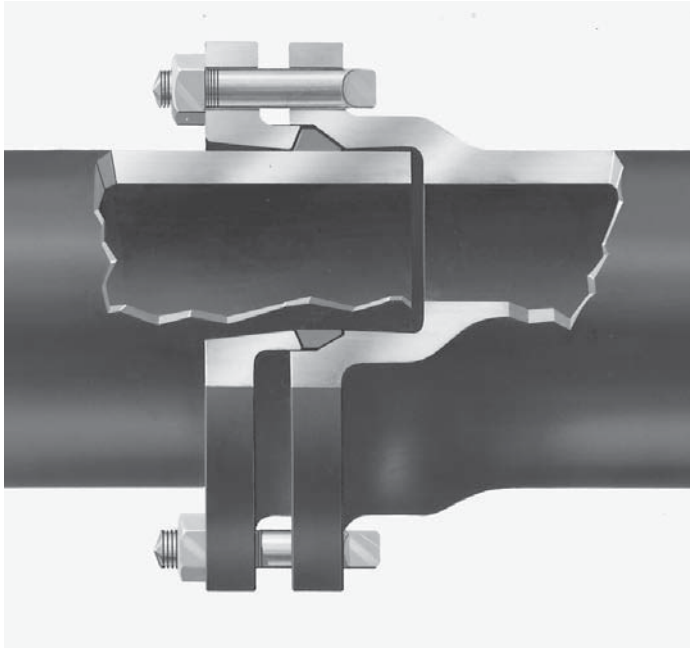


FIGURE 21.23 Bell and spigot connection. Courtesy Griffin Pipe Products Co.



**FIGURE 21.24** Typical mechanical joint connection. Courtesy Griffin Pipe Products Co.

## Solvent Welding Connection

Solvent welding pipe connection, also known as **cementing** or **gluing**, is used on plastic pipe. The solvent is applied to the pipe end, which is then inserted in the socket opening of a fitting and twisted to secure and spread the glue. The solvent creates a bonding that acts similar to a weld. Plastic pipe can also be joined by **hot gas welding** in which a torch is used to melt the pipe and fitting together.

## Flaring Connection

Soft copper pipe and tubing can be joined by a method called **flaring**. A special tool is clamped on the pipe, and the flaring tip is inserted into the end of the pipe. As the tip is rotated, it is forced into the pipe, spreading or expanding the end of the pipe open—that is, flaring. A fitting called a **swage** is then used to connect the flared end to a pipe or a fitting.

## PIPE FITTINGS

**Pipe fittings** allow pipe to change direction and size and provide for branches and connections. Each type of pipe and connection method discussed previously uses the same type of fittings. However, special fittings can be required by the nature of the connection method. The following is a general discussion of common fittings used in industry today.

### Welded Pipe Fittings

Seamless forged steel fittings are prepared with a beveled end to accommodate butt welding. A **welding ring**, shown in

Figure 21.25a, is placed between the pipe and fitting to aid in alignment, provide even spacing, and prevent weld material from falling into the pipe (see Figure 21.25b). Fittings have the same schedule numbers and wall thickness as pipe. A smooth inside surface is produced at the joints when fittings and pipe of the same schedule number are welded together.

The most familiar fittings are **elbows** and **tees**. Welded fittings are shown in Figure 21.26. Standard shapes are the 90° and 45° elbows. The **90° reducing elbow** reduces the pipe size in addition to changing direction. A reversal in direction can be achieved by using a **180° elbow**. Standard elbows can also be cut to any angle required. A **mitered elbow** is produced by cutting and welding straight pipe to create the desired elbow. The mitered elbow can be composed of one, two, three, or more welded joints (see Figure 21.27). A mitered elbow is not used often because it produces considerably more turbulence than standard elbows. An installation of the mitered elbow is shown in Figure 21.28.

The diameter of the pipe can be changed using **reducers**. The **concentric reducer** tapers the pipe equally around the axis centerline of the pipe. The **eccentric reducer** has a flat side that allows one side of the pipe—typically the top or bottom—to remain level.

The **straight tee** is a standard fitting that creates a branch or inlet. The straight tee has the same diameter on all three openings. The **reducing tee** has a smaller opening on the outlet side of the fitting. A branch or inlet can also be created with a **lateral**. A lateral fitting provides a 45° branch of the **run** pipe. The run is the straight portion of the fitting. The lateral is available in both straight and reducing forms. The **true Y** is similar to the lateral but produces branches that are at a 90° angle, forming a Y with the run pipe. A branching fitting similar to the tee is the **cross**. A cross has two branches opposite each other. The cross can be either straight or reducing. A cross is found in special situations and tight spaces but is seldom used because of its expense.

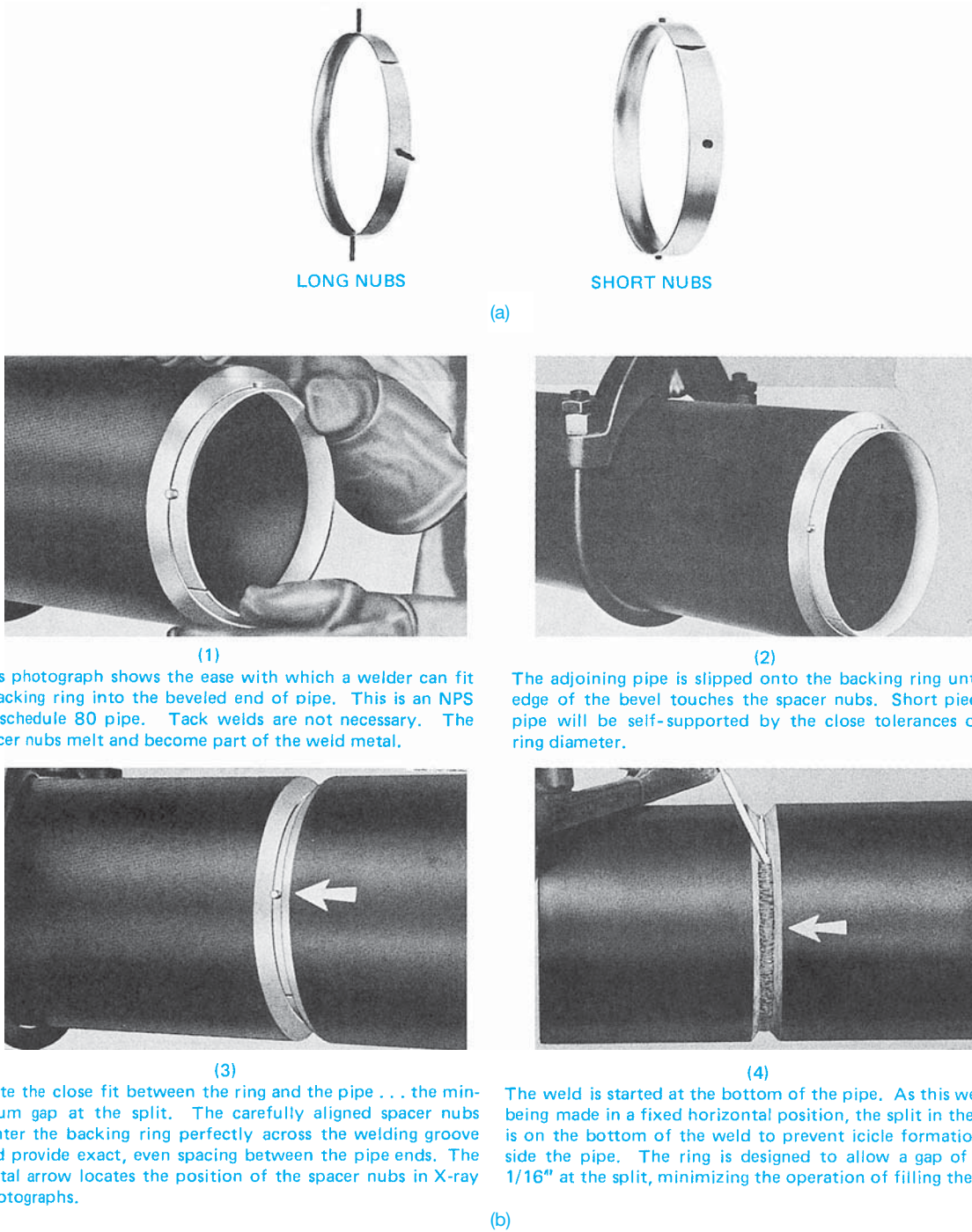
There are several small fittings that are less expensive than regular fittings. Small fittings are used to create branch connections in new installations or on pipe that is already assembled. These small fittings are commonly called **weldolets**® and are manufactured to accept welded, screwed, socket-welded, and **brazed** pipe. These small fittings can be welded to an elbow at a 45° angle and are referred to as a **elbolet**®. They can be welded to the run pipe where they are called a **latrolet**®. They can also be welded at a 90° angle to the run pipe where they are called a **weldolet**®. Brazing is a process for joining similar or dissimilar metals using a filler metal that typically includes a base of copper combined with silver, nickel, zinc, or phosphorus (see Figure 21.29).

Appendix W, Table 30 provides dimensions for seamless welded fittings.

### Screwed Pipe Fittings

All welded fittings are available in threaded form. In addition to these, several special fittings are used with screwed pipe.





This photograph shows the ease with which a welder can fit a backing ring into the beveled end of pipe. This is an NPS 6" schedule 80 pipe. Tack welds are not necessary. The spacer nubs melt and become part of the weld metal.

The adjoining pipe is slipped onto the backing ring until the edge of the bevel touches the spacer nubs. Short pieces of pipe will be self-supported by the close tolerances of the ring diameter.

Note the close fit between the ring and the pipe . . . the minimum gap at the split. The carefully aligned spacer nubs center the backing ring perfectly across the welding groove and provide exact, even spacing between the pipe ends. The metal arrow locates the position of the spacer nubs in X-ray photographs.

The weld is started at the bottom of the pipe. As this weld is being made in a fixed horizontal position, the split in the ring is on the bottom of the weld to prevent icicle formation inside the pipe. The ring is designed to allow a gap of only 1/16" at the split, minimizing the operation of filling the gap.

FIGURE 21.25 (a) Common welding rings with long nubs and short nubs. (b) Pipe-joining process using a welding ring.

Courtesy/ITT Grinnell Corp.

Appendix W, Table 31 provides dimensions for galvanized malleable iron fittings. Figure 21.30 illustrates screwed fittings.

### Union

A **union** is composed of two threaded sleeves and a threaded union ring, this fitting provides a connection point in a straight run of pipe. A union allows pipe to be broken apart without tearing down the entire run of pipe.

### Coupling

A coupling is **threaded at both ends (TBE)** with internal threads and is used to attach two lengths of pipe together.

### Half coupling

A **half coupling** is **threaded at one end (TOE)** and is often welded to pipes and used for instrument connections.



90° ELBOW



90° REDUCING ELBOW



45° ELBOW



STRAIGHT TEE



REDUCING TEE



CROSS



CONCENTRIC REDUCER



ECCENTRIC REDUCER



CAP

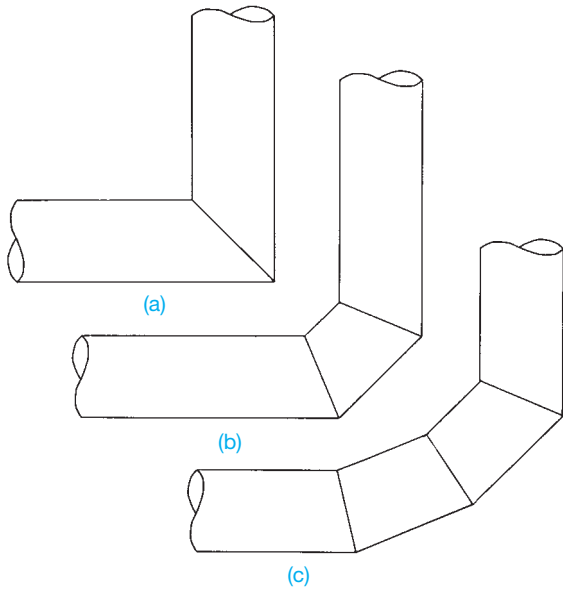


STRAIGHT LATERAL



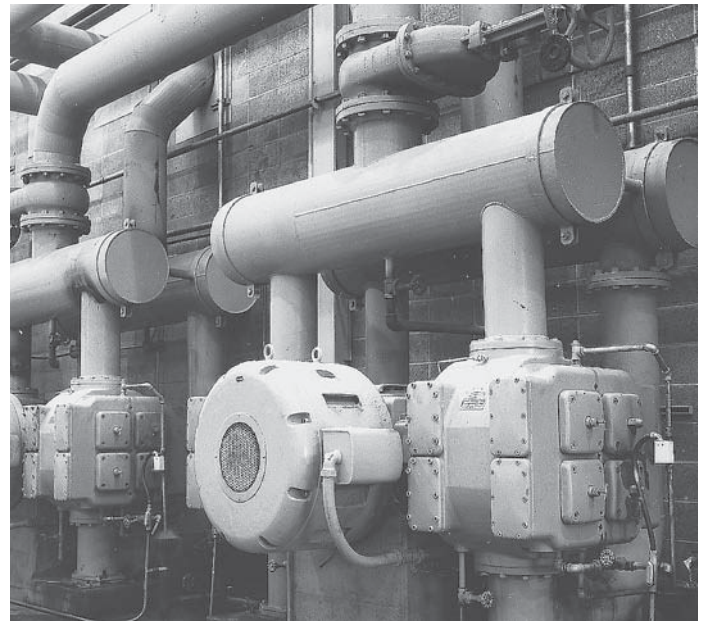
REDUCING LATERAL

FIGURE 21.26 Welded seamless fittings. Courtesy ITT Grinnell Corp.

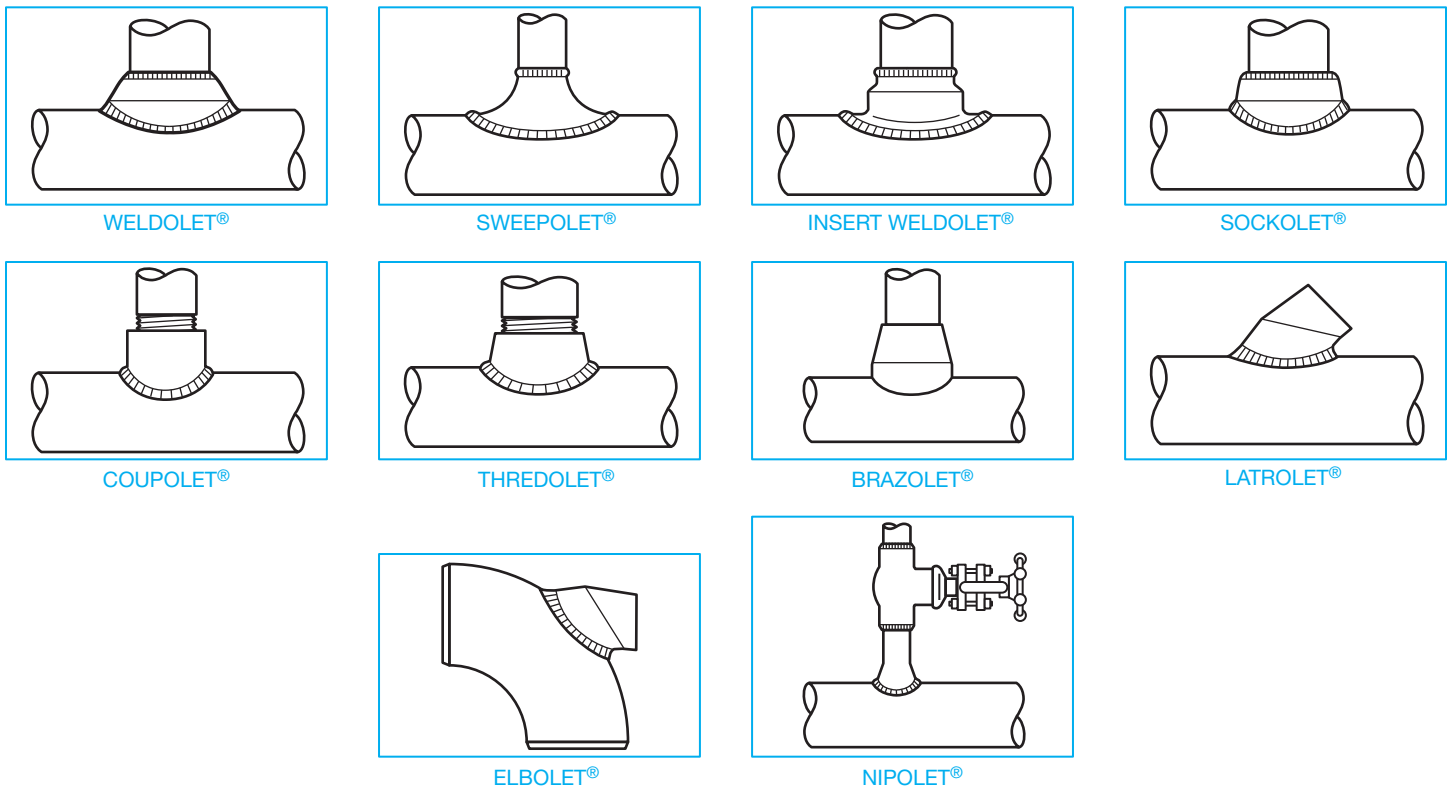


© Cengage Learning 2012

**FIGURE 21.27** The mitered elbow is composed of several cut pipe segments: (a) Two-piece miter. (b) Three-piece miter. (c) Four-piece miter.



**FIGURE 21.28** Mitered elbows in a vacuum pump installation at a paper mill. Courtesy Ingersoll-Rand Company



**FIGURE 21.29** Branch connections can create inlets or outlets of varying sizes and angles to the main run of pipe and at less expense than regular fittings. Courtesy Bonney Fogre Division, Gulf & Western

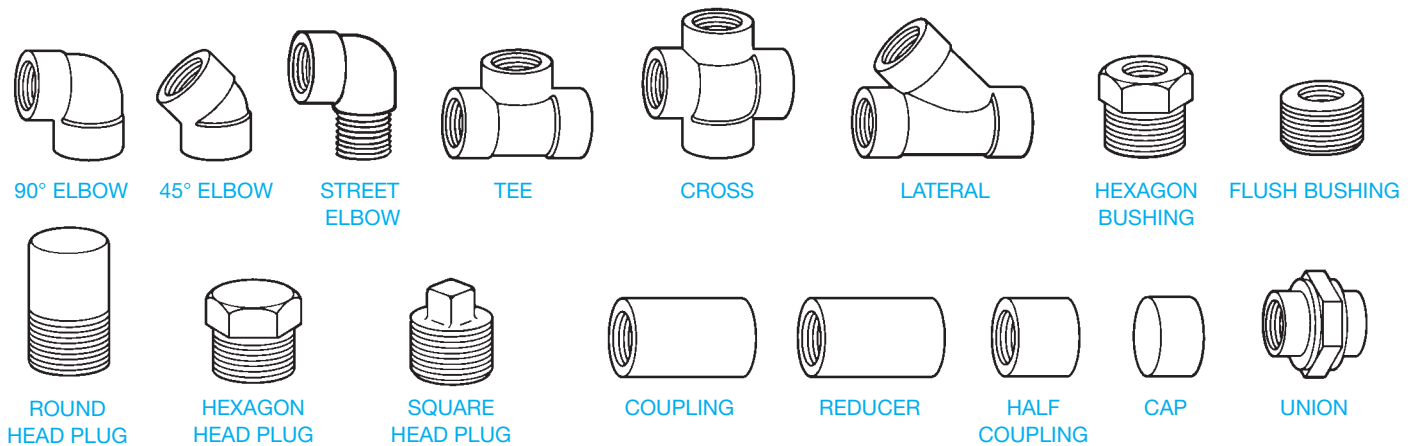


FIGURE 21.30 Common screwed fittings.

### Street Elbow

A **street elbow** is a 90° elbow threaded at one end with internal threads and the other end with external threads. The street elbow can be attached directly to a fitting, thus eliminating the need of a short piece of threaded pipe called a **nipple**.

### Bushing

A **bushing** is a reducing fitting used to connect a small pipe to larger fittings.

### Plug

A **plug** is a fitting with external threads on one end that is used to seal the screwed end of a fitting or pipe.

## FLANGES

A **flange** is the component that creates a bolted connection point in welded pipe. A flange is a circular piece of steel containing a center bore that matches the pipe ID to which the flange is attached. A flange has several bolt holes evenly spaced around the center bore. Flanges are used extensively on welded pipe but are also available for most other types of pipe. Figure 21.31 shows several types of flanges. Appendix W, Table 24 provides flange dimensions.

As previously described, pipe and other fittings are identified using the schedule classification to indicate their thickness and strength. Flanges and valves are classified by a rating system. An engineer generally selects the rating of flanges and valves to be used in a project by taking the design pressure and temperature, which is the operating pressure and temperature plus a safety factor, and comparing it to the manufacturer information about the flange. The engineer then uses these tables of data to select the proper rating. Thicker and larger flanges have a higher flange rating.

Ratings can be listed in many different ways, such as 150#, Class 150, and 150 CL are all common abbreviations to list a 150-class flange or valve. When putting **nozzles** and flanges together, or flanges and valves together, the ratings of the connecting objects must be the same. The connecting objects must be the same, because they are operating under the same conditions, and the

same ratings have the same bolt hole configurations. Objects cannot physically be assembled together if they are different ratings. A **nozzle** is a spout projecting from a piece of equipment, such as a heat exchanger, from which a fluid is discharged.

### Slip-On Flange

A **slip-on flange** can only be used on straight pipe, because it is bored to slip over the end of the pipe. Two welds are required to attach a slip-on flange to pipe. There are two types of slip-on flanges (see Figure 21.32).

#### STANDARDS

**ASME** When the type 1 slip-on flange is used, the pipe is set back from the face of the flange. It has two-thirds the strength of a weld-neck flange and is limited to 300 lb service by the ASME *Pressure Piping Code*. The type 2 slip-on flange allows the pipe to be welded flush with the face of the flange, which is then machined flat. This type of flange is used on lines having 400 lb pressure and more.

### Weld-Neck Flange

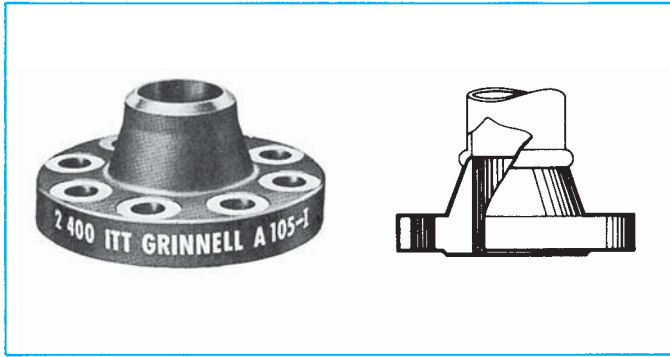
The **weld-neck flange** is forged steel and prepared with a beveled end for butt welding to pipe or fittings. A weld-neck flange is always used when a flange must be attached directly to a fitting.

### Blind Flange

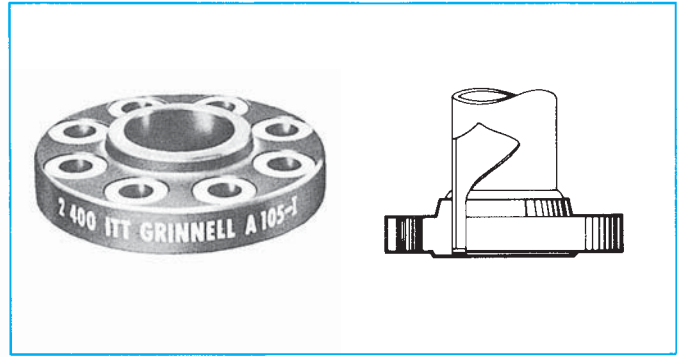
A pipe can be temporarily sealed with a **blind flange**, which is a steel plate with bolt holes.

### Stub-End or Lap-Joint Flange

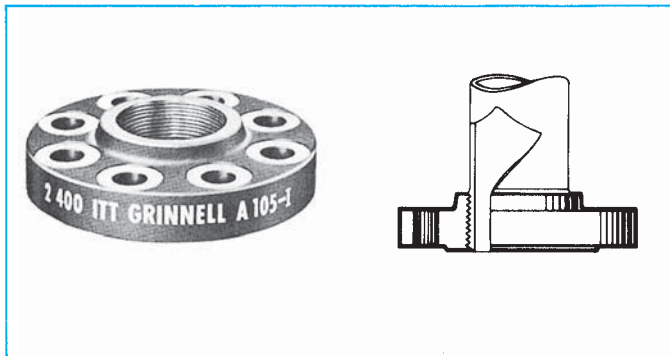
The **stub-end** or **lap-joint flange** is composed of two parts: the stub end and the flange ring. The flange ring can be carbon steel if expensive pipe such as stainless steel is used. Only the stub end needs to be made out of stainless steel.



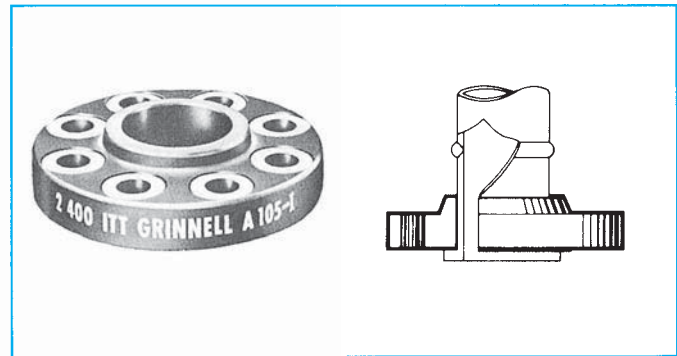
WELDING NECK



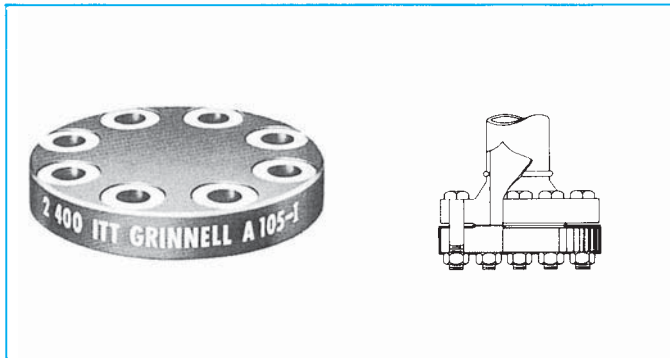
SLIP-ON



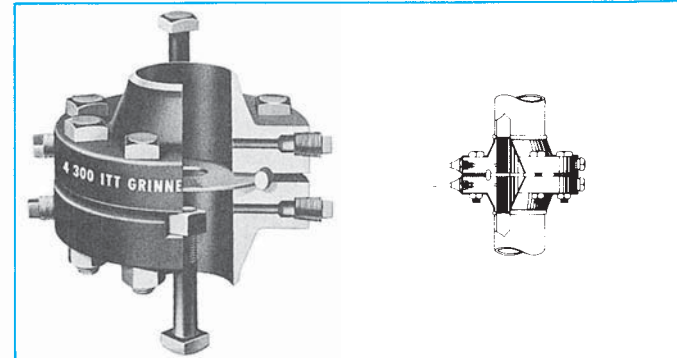
THREADED



LAP JOINT



BLIND



ORIFICE

FIGURE 21.31 Common flanges used on butt-welded steel pipe.

Courtesy ITT Grinnell Corp.

## Reducing and Expander Flange

A change in line size can be achieved with a **reducing flange**, but it should not be used where increased turbulence is undesirable. A reduction in line size can also be created with an **expander flange**. An expander flange fitting is a flange and reducer combination and can be used in place of a weld-neck flange and a reducer.

## Orifice Flange

The flow rate inside a pipe can be measured using **orifice flanges** and an **orifice plate**. The two orifice flanges are drilled

and tapped to accommodate tubing, and a pressure gage is used to measure the flow rate. The orifice plate is a flat disc with a small hole drilled in its center. The two flanges are welded to the pipe. The orifice plate and gaskets are placed between the flanges, and the flanges are bolted together. As fluid flows through the hole in the orifice, a pressure differential is created on either side of the plate. This pressure differential can be read on the pressure gage.

## Flange Faces

The **facing** of a flange is the type of machining that is done to the contact surface of the flange. A common flange used in

industry is the **raised face (RF)** flange. The face of this flange extends a distance beyond the flange. The **male and female facings** interlock with each other. A recessed face on the female flange accepts both the gasket and the raised face of the male flange. A **tongue-and-groove facing** is interlocking. In a tongue-and-groove facing, the male tongue-and-groove flange

is 1/4" longer than the female flange to accommodate the height of the tongue. The tongue fits into the groove, creating a tighter lock and seal. Figure 21.32 shows cross sections of the tongue-and-groove flange faces.

The **ring-type joint (RTJ)** flange connection requires two flanges that both have a machined groove in the face. This groove is cut to accept an oval or octagonal ring. The grooves on both flanges fit over the ring, creating a seal. Examples of the ring joint flange are shown in the cutaway photo of the orifice flange in Figure 21.31 and in the section view in Figure 21.32.

## VALVES

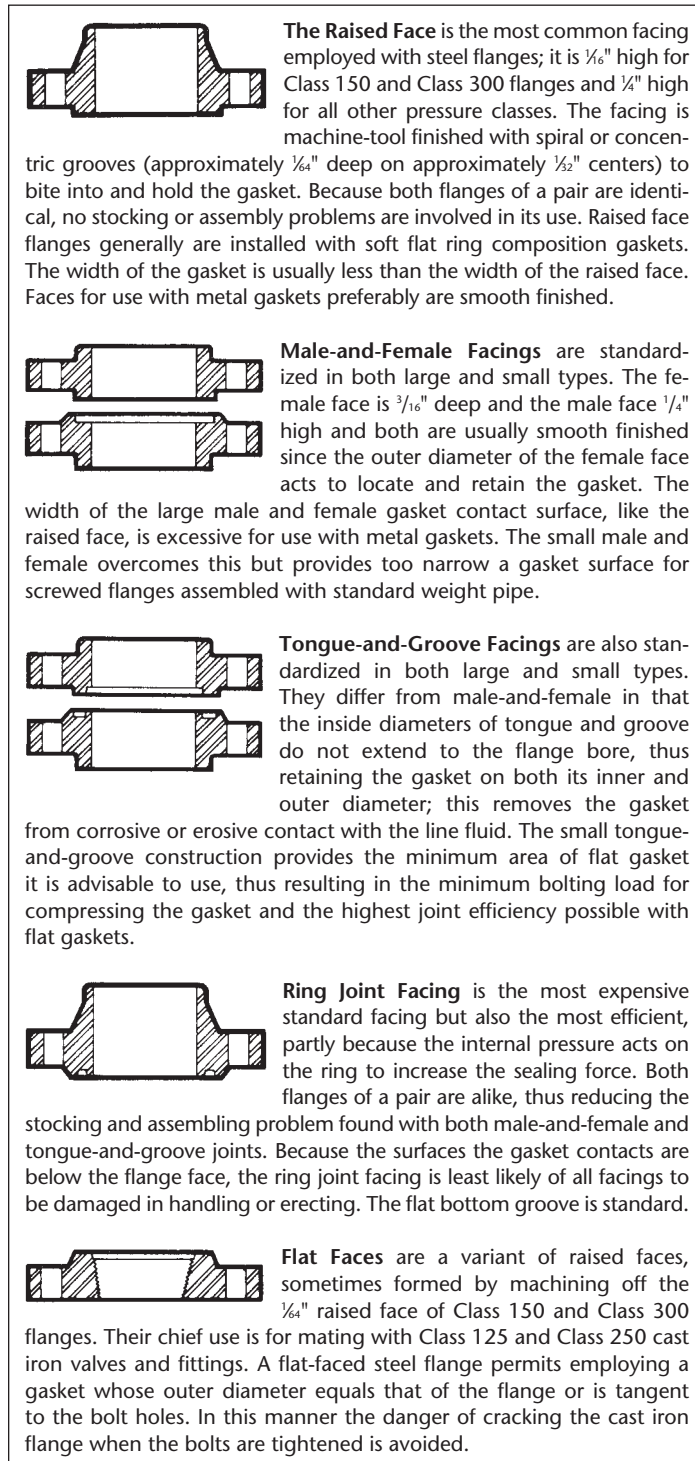
**Valves** are the components in the piping system that control and regulate fluids. Valves provide on-off service in a pipe and are used to regulate the flow of fluid in the pipe, maintain a constant pressure, prevent dangerous pressure buildup, and prevent backflow in the pipe. Varieties of valves are used to perform these tasks. Valves are often found in **valve assemblies**. A valve assembly is comprised of a flange, gasket and bolt set, the valve, and then another gasket, flange, and bolt set. The bolt set has one bolt, washer, and nut for each hole.

### On-Off Valve

The **gate valve** is used exclusively to provide on-off service in a pipe. The gate valve is the most common valve used in industry (see Figure 21.33). The gate valve functions by a gate or disc that is moved up and down inside the valve manually or automatically. The design of the gate valve is such that fluid can flow through it with a minimum of friction and pressure loss. The valve seat does not interfere with the straight line flow of the fluid. The seat is the material with which the gate makes contact to create a seal. The gate valve is designed specifically for on or off service and infrequent operation. It is unsuitable for throttling or regulating flow. A partially open gate can cause erosion and wear of the downstream side of the seat and the disc.

The sealing mechanism inside a **ball valve** is a ball. The ball has a hole through it that matches the ID of the pipe (see Figure 21.34). The ball valve is a quick-opening valve, requiring only a one-quarter turn, and is used extensively because of its tight seat. Plastics, nylon, and synthetic rubber are used for the seat material, allowing this valve to achieve a tight seal. The ball valve is popular because it has a low profile and low torque requirement for operation. It is also easy and inexpensive to maintain and repair. A ball valve is not used in large-diameter lines greater than 12" (300 mm) because the pressure in the line makes it difficult to open and close.

The **plug valve**, also known as a cock valve, is similar in design to the ball valve and requires only a one-quarter turn to open and close. The opening through the plug can be either rectangular or round (see Figure 21.35). When open, there is a pressure drop through the valve but high flow efficiency because of the contours of the valve. A plug valve has low throttling ability and is best used for on-off service. It can achieve a tighter shutoff than a gate valve but is normally used on smaller-diameter lines.



**FIGURE 21.32** Cross-section view and specifications for common flange faces. Courtesy IIT Grinnell Corp.

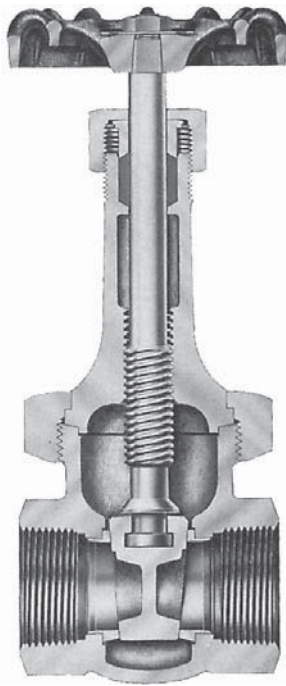


FIGURE 21.33 The gate valve provides on–off service.

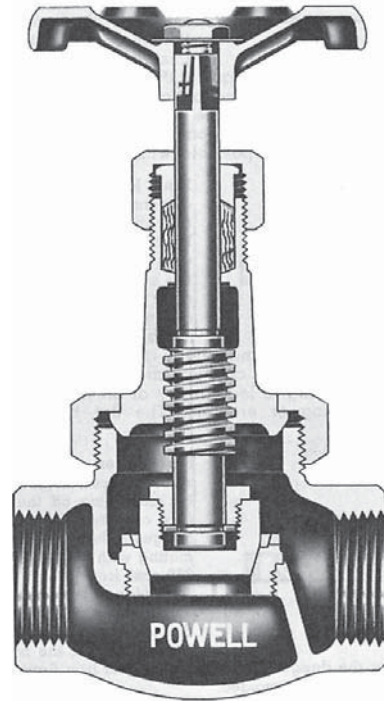


FIGURE 21.36 The globe valve achieves close flow control but creates high flow resistance.

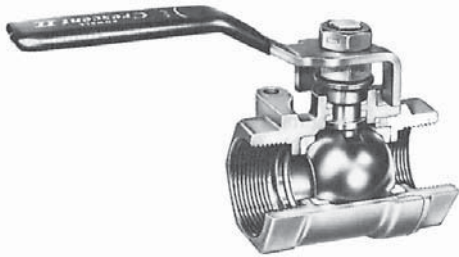


FIGURE 21.34 The ball valve is quick-opening and is used in pipe less than 12" in diameter.

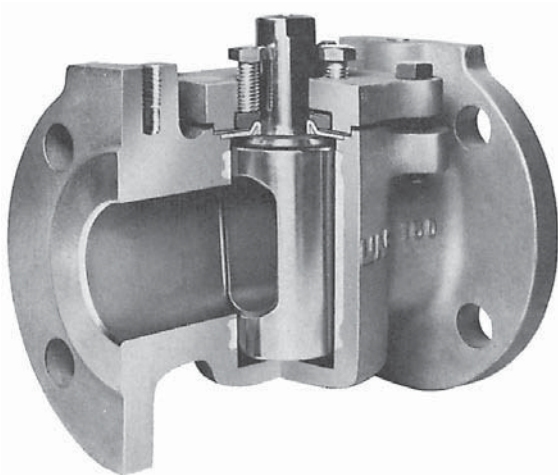


FIGURE 21.35 The plug valve achieves tighter shutoff than a gate valve but is used on small diameter lines.

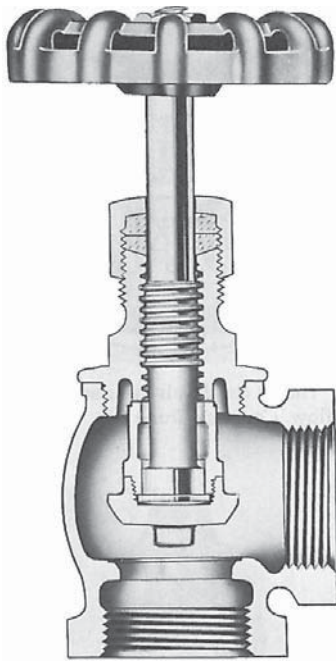
## Regulating Valve

The most common type of **regulating valve** is the **globe valve**. A globe valve is normally used in pipe up to 3" (75 mm) diameter but can be used in lines with up to 12" (300 mm) diameter. Fluid flowing through the globe valve travels in an S pattern, which allows the valve to maintain a close control on the flow and to achieve a tight, positive shutoff. Figure 21.36 shows the flow pattern of a globe valve. The internal design of the globe valve creates a high flow resistance, leading to a significant pressure drop through the valve. Body pockets in the valve do not drain when the flow stops. Situations that require frequent valve operation and maintenance are suited for globe valves, because the discs and seats are easy to replace.

A special type of globe valve that creates a 90° direction change in the pipe is an **angle valve**, which is similar in design to a globe valve and is used in place of a globe valve and a 90° elbow to save money (see Figure 21.37). The angle valve is not used in high-stress situations.

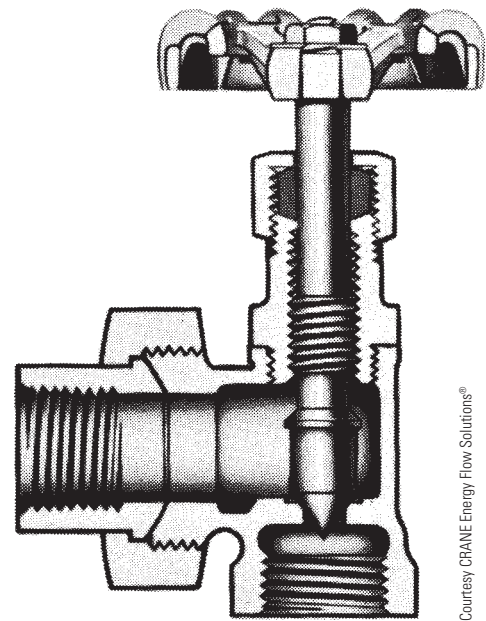
Low-pressure situations can be a good application for the **butterfly valve**. The disc mounts on a stem that turns one-quarter to open and close. The entire disc moves inside the valve (see Figure 21.38). The butterfly valve is a simple operating mechanism that is excellent for regulating flow. The design creates a minimum pressure drop through the valve. It is light and inexpensive, requires a small installation space, and is easy to maintain. All-plastic butterfly valves are also available.

The **needle valve** is named because the end of the stem is needle shaped (see Figure 21.39). The stem has fine threads that allow this valve to be adjusted exactly to achieve accurate



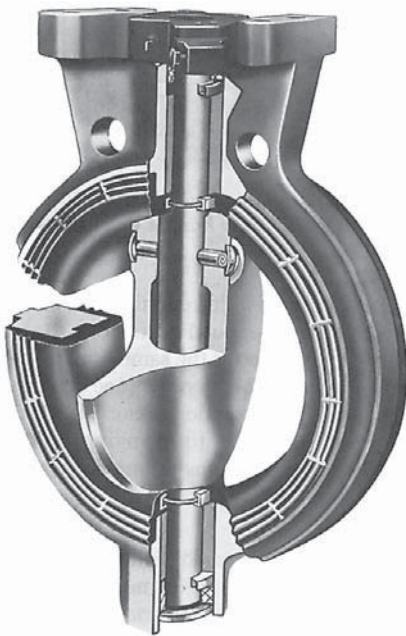
Courtesy CRANE Energy Flow Solutions®

**FIGURE 21.37** The angle valve replaces the globe valve and an elbow.



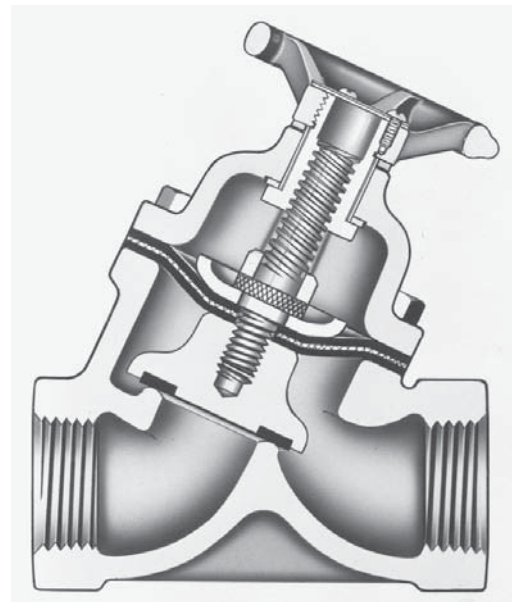
Courtesy CRANE Energy Flow Solutions®

**FIGURE 21.39** The needle valve is good for accurate throttling on instrument and meter lines.



Courtesy CRANE ChemPharma Flow Solutions®

**FIGURE 21.38** The butterfly valve is excellent for regulating flow and creates a minimum pressure drop.



Courtesy CRANE ChemPharma Flow Solutions®

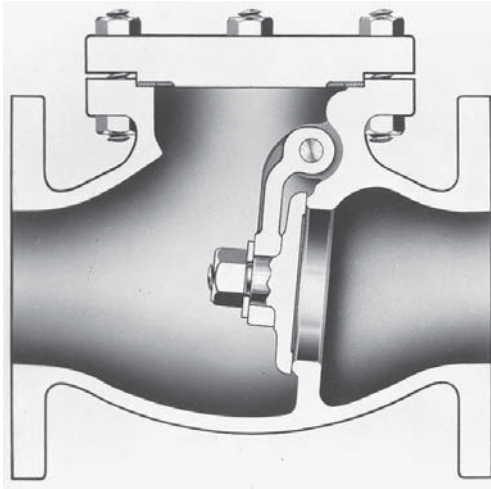
**FIGURE 21.40** The diaphragm valve protects the valve mechanism from the fluid.

throttling. The flow through the needle valve changes direction much like the flow through a globe valve. The needle valve is used for high-temperature and high-pressure service in instrument, gage, and meter lines.

Some types of service require that the working parts of the valve be sealed from the fluid stream. The protection of the valve parts is important when working with fluids that are corrosive, viscous, fibrous, or contain suspended solids and **sludge**. Sludge is semisolid material such as the type

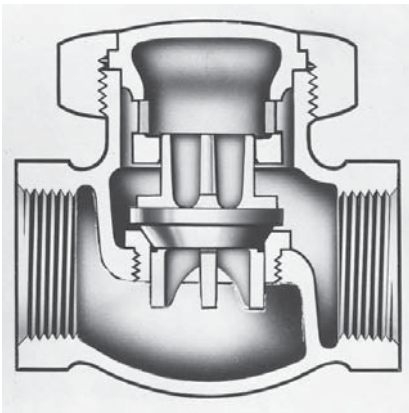
precipitated by sewage treatment. The protection of the fluid is most important when dealing with food and beverages. The **diaphragm valve** suits this need. In the diaphragm valve, a diaphragm of rubber, neoprene, butyl, silicone, or other flexible material is used in place of a disc or other type of sealing mechanism. The stem pushes down the diaphragm and creates a seal against a seat on the bottom of the valve (see Figure 21.40). The diaphragm also serves to protect the working parts of the valve. The diaphragm valve has a smooth, streamlined flow, is easy to maintain, achieves positive flow control, and is leak tight. It is suited for both on-off and regulating services up to 400°F (204°C).





Courtesy CRANE Energy Flow Solutions®

**FIGURE 21.41** The disc inside the swing check valve operates by gravity to check backflow.



Courtesy CRANE Energy Flow Solutions®

**FIGURE 21.42** The lift check valve is used with the globe valve to check backflow.

## Backflow Valve

Certain situations require that fluids be prevented from flowing backward in the pipe if a power failure or pump breakdown occurs. **Check valves** prevent backflow by closing when the fluid stops flowing.

The **swing check valve**, as shown in Figure 21.41, is similar in construction to the gate valve and is used with a gate valve. The disc inside the swing check valve operates by gravity or the weight of the disc. The swing check valve is best used with low-velocity liquids. The **lift check valve** in Figure 21.42 is similar to the globe valve and is used with a globe valve. A lift check valve operates by gravity and is available in either horizontal or vertical models.

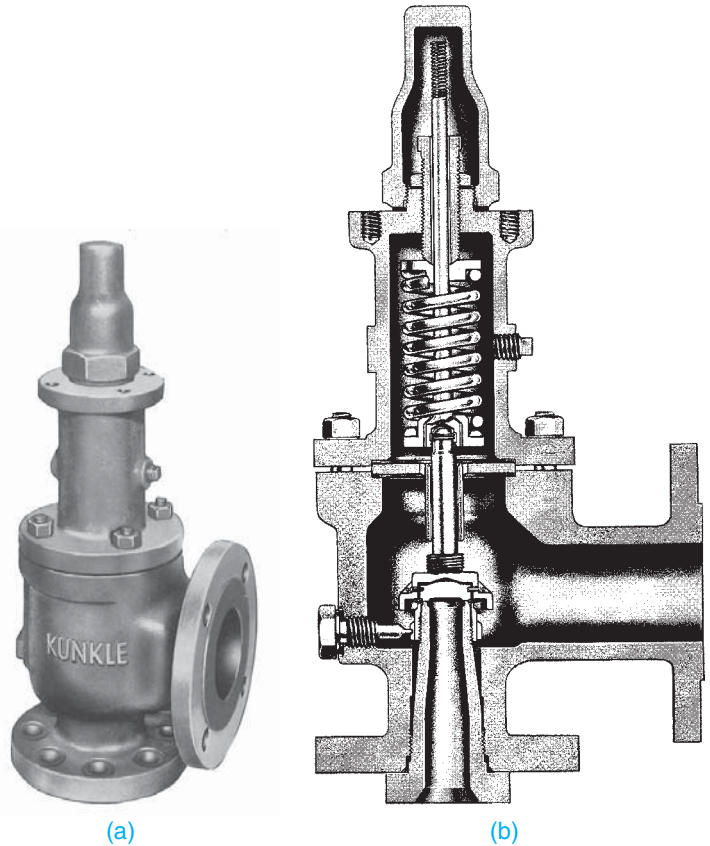
## Safety Valve

The high temperatures and pressures within many industrial processes are potentially dangerous and must be controlled and regulated to prevent serious accidents. **Safety valves** and **relief valves** are responsible for keeping pressures at or below a given point.



Photo courtesy of Tyco Flow Control

**FIGURE 21.43** The pop safety valve provides a momentary release of pressure.

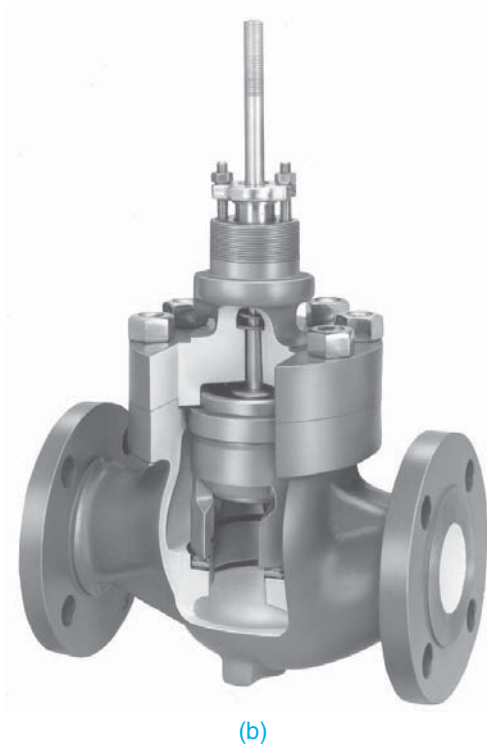


**FIGURE 21.44** (a) Relief valve exterior. (b) Cutaway view. Relief valve provides slow release of fluids and pressure. Courtesy Kunkle Valve Co., Inc.

The pop safety valve actually pops wide open when the pressure in a pipe or piece of equipment reaches a set pressure. Pop safety valves are used for steam, air, and gas lines only and never used for liquids. The opening and closing of this valve is instantaneous (see Figure 21.43).



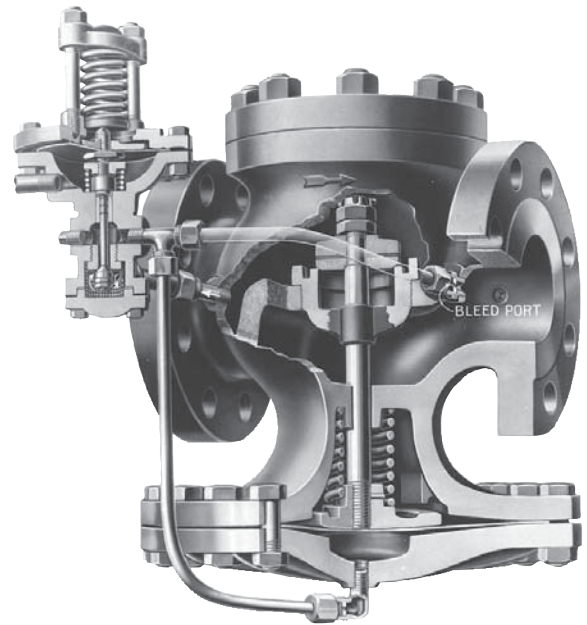
(a)



(b)

Courtesy DeZurik Valve Company

**FIGURE 21.45** (a) Cage guided control valve exterior view. (b) Cutaway view of cage guided control valve.



Courtesy Spence Engineering Co., Inc.

**FIGURE 21.46** Pressure regulator.

The relief valve performs the same function as the pop safety valve but is used for liquids only (see Figure 21.44). The relief valve is also set to open at a specific pressure, but it opens and closes slowly in response to changing pressure. This type of valve is found on most home hot-water heaters.

## Control Valve

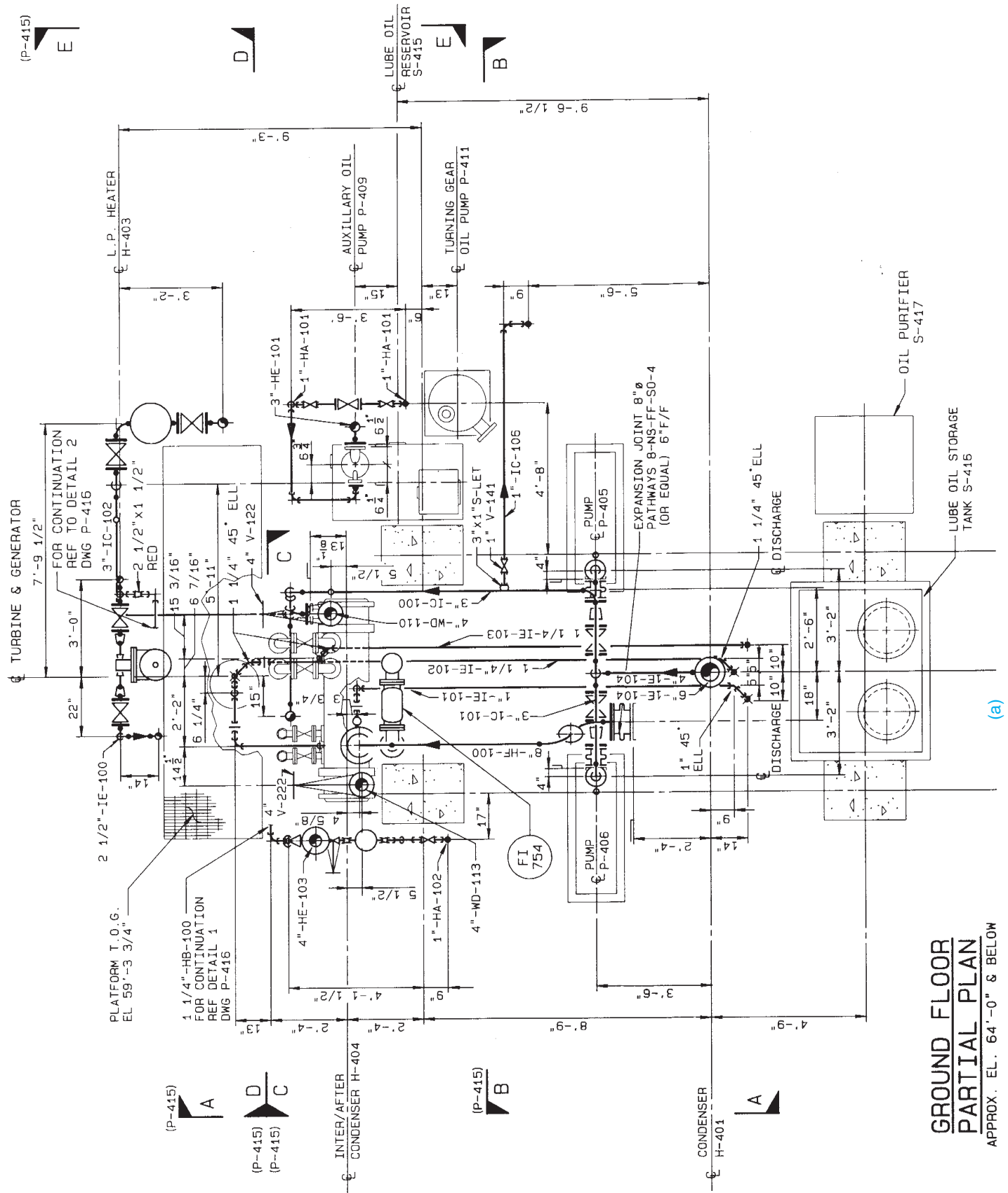
**Control valves** are used when the complex processes used in industry often demand instantaneous control and adjustment of flow, pressure, and temperature. Most any type of valve can be a control valve. The example in Figure 21.45 shows one of the types used. The identifying component of the control valve is the controller or actuator, which is the mechanism that operates the valve. The actuator can be operated by an electric motor, air cylinder, or hydraulic cylinder.

## Pressure Regulating Valve

**Pressure regulators** are used in steam processes that require a constant flow at a steady rate. A pressure regulator mechanism reduces the incoming pressure of the steam to the required service pressure. The regulator maintains the pressure at the specified level and provides a uniform flow (see Figure 21.46).

## PIPE DRAFTING

Pipe drafting positions are found with consulting engineering companies, large industrial construction firms with engineering offices, and manufacturers of equipment that use piping. The entry-level drafter in these companies can begin by drawing revisions, known as **markups**, to existing drawings. Revisions can take place on flow diagrams, which are nonscale schematic drawings, or on piping drawings. As experience is gained, the



**GROUND FLOOR  
PARTIAL PLAN**  
APPROX. EL. 64'-0" & BELOW

**FIGURE 21.47** (a) Partial piping plan of a turbine generator installation. Courtesy Schuchart & Associates

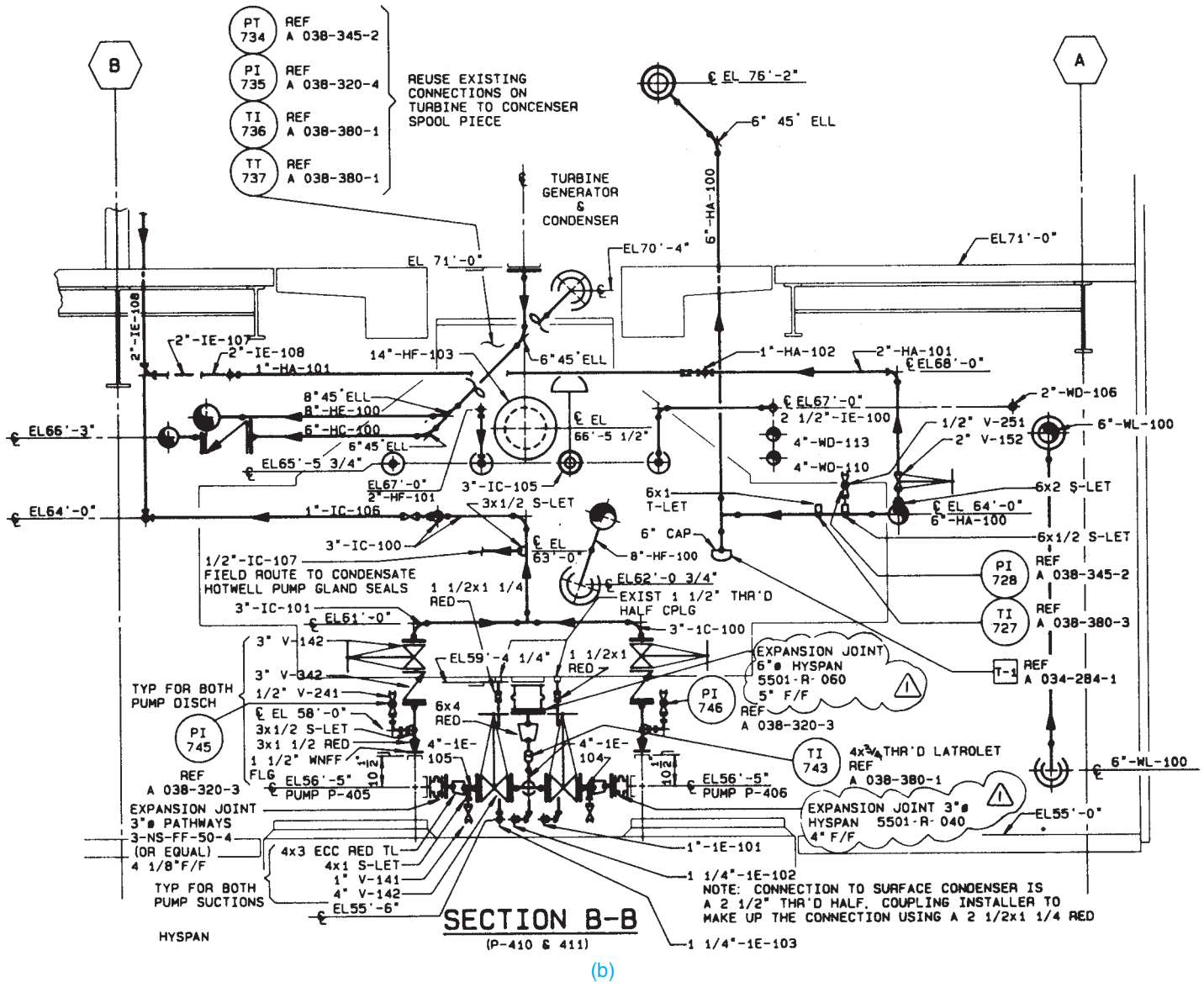


FIGURE 21.47 (Continued) (b–e) Piping sections are taken from plan in (a).

drafter is assigned more complex drawings that are constructed from engineering sketches.

Engineers, designers, and technicians design the piping system, select and size the equipment and pipe, and give this information to the drafter. The drafter’s task is to construct the required type of drawing or model or to develop specifications, often using vendor catalogs, brochures, and charts, or other drawings containing reference information. Once a working knowledge of the subject is gained, the drafter can be given the responsibility of designing and laying out pipe runs. At this point, the drafter begins to use his or her knowledge of pipe fittings and reference information.

### Piping Specifications

A **piping specification** is a subset of piping components that has been selected to meet the criteria for a set of given

conditions, mainly design and operating pressures and temperatures, and the composition of the material being transported. A company may have 20 or more of these specifications, depending on the range of processes and conditions on which they work.

Piping specifications, commonly referred to as **specs**, are generally designed by engineers, and they must be strictly adhered to during the piping design process. The specification determines any or all of the following:

- Material of the piping.
- Allowable fittings.
- Thickness or schedule of the pipe and fittings.
- Identification if small bore piping is to be threaded or socket welded.
- Sizes of items in the project.

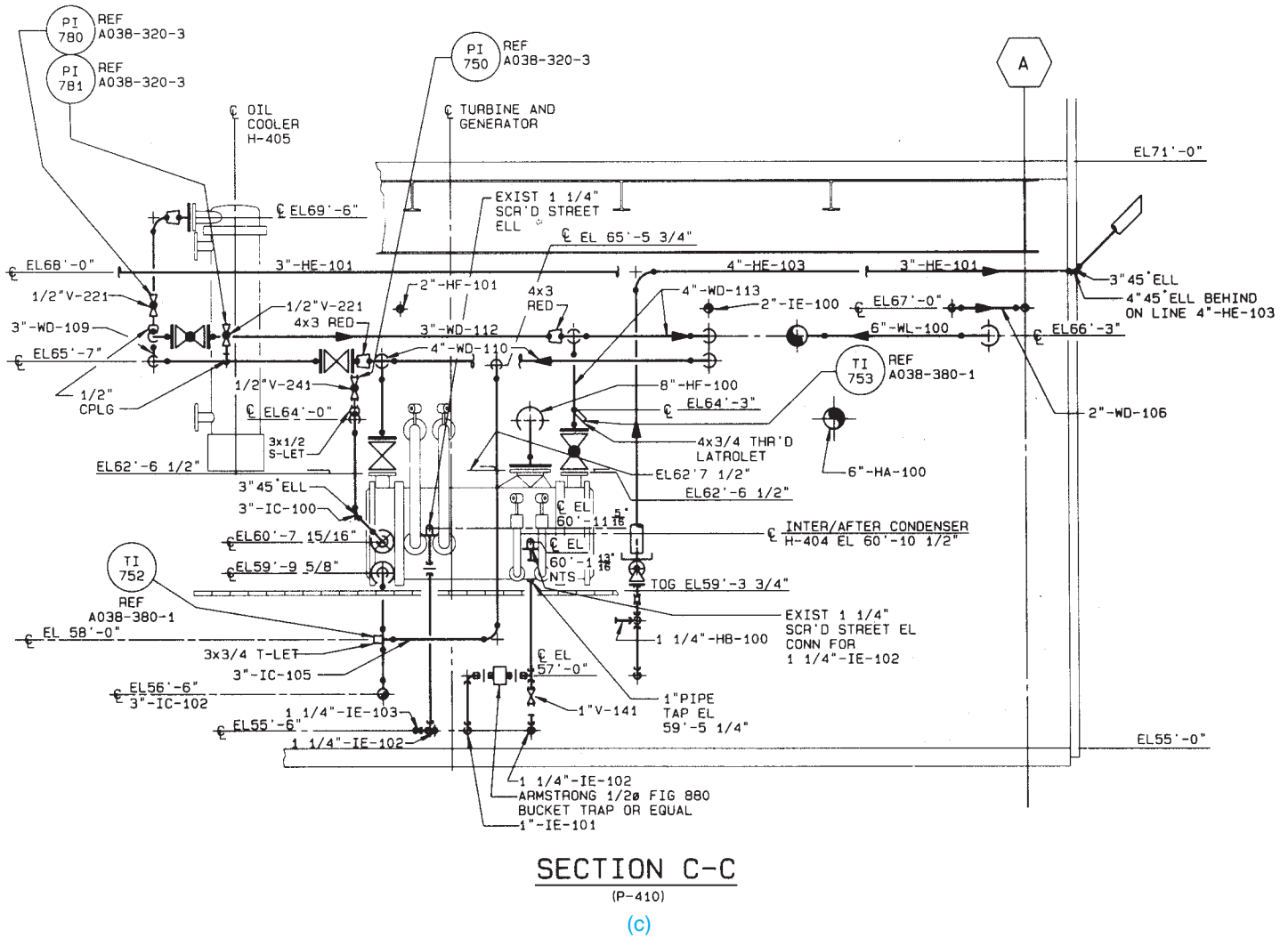


FIGURE 21.47 (Continued)

Some specifications also include a branch-fitting table, which defines the fitting to be used for various main and branch sizes. For example, the branch-fitting table can define that a 4" × 3" branch should always be a reducing tee, whereas a 6" × 1" branch should be a threadolet.

Many companies label process lines in their PFD and P&ID drawings to include the various specification names. This allows other drafters and engineers to recognize information about the pipeline at a single glance, and it determines what the spools look like as more detail is added to the drawings at the 2-D drafting stage.

## Plans and Sections (Elevations)

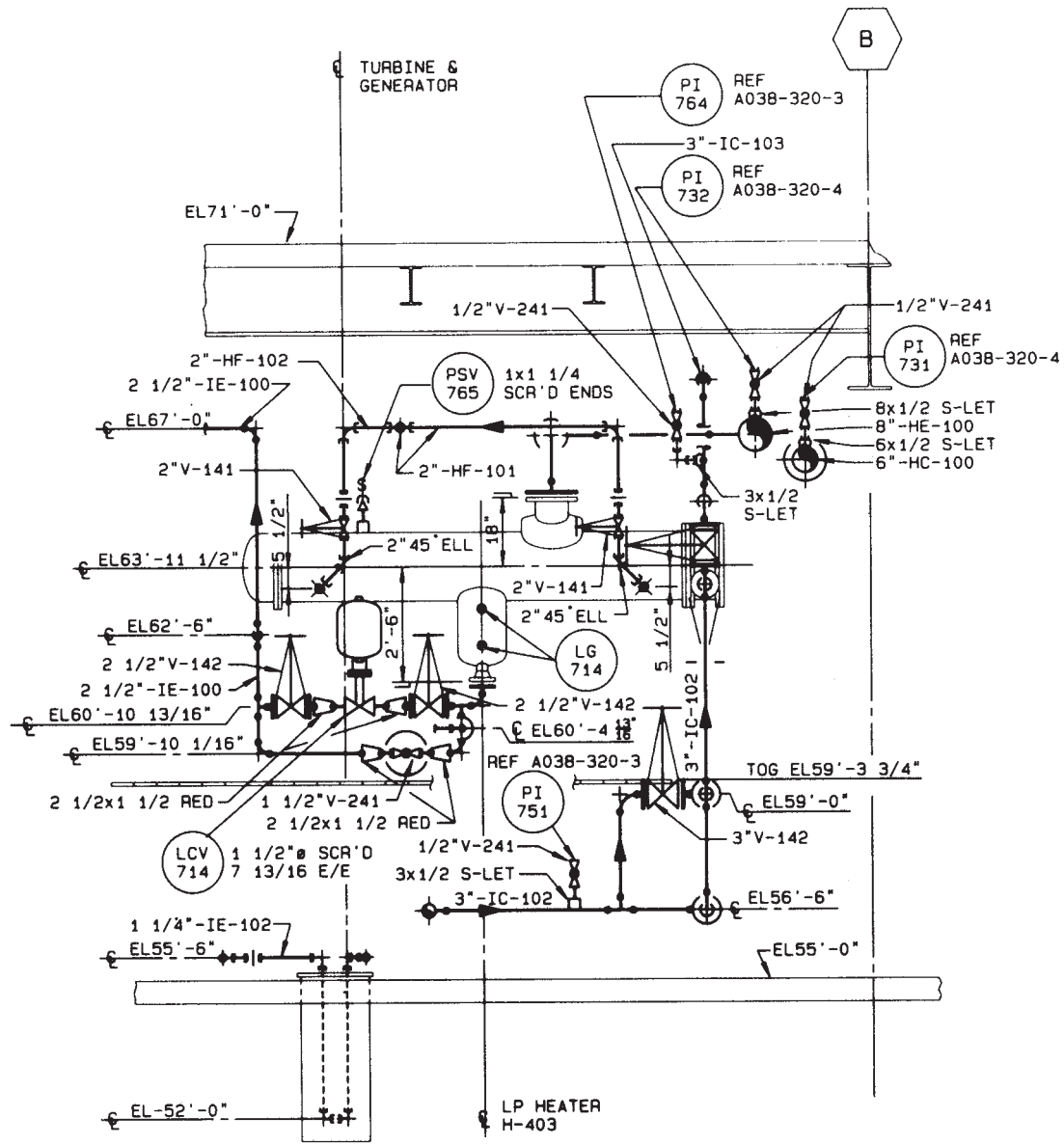
The most common and the most complex type of piping drawings are **plans** and **sections** that show building outlines, equipment, pipe, and pipe supports. Figure 21.47 shows examples of a plan and several sections taken from the plan. Study these drawings carefully. Look at the plan and sections together to try to

determine where specific pipe runs are located. A little time spent now aids you in working with this type of drawing in the future.

Equipment shown on piping plan and section drawings is seldom drawn in detail, but instead an outline is used to illustrate clearances and access. Tanks, vessels, heat exchangers, pumps, columns, compressors, boilers, dryers, and reactors are just a few examples of some of the equipment found on pipe drawings.

## Pipe Supports and Hangers

In addition to major pieces of equipment, the drafter can be required to indicate pipe supports and hangers. Figure 21.48, page 896, shows a pipe system with extensive use of pipe hangers in the form of pipe clamps and iron rods. Pipe supports must also come from the bottom up, as shown in Figure 21.49, page 897. Pipe supports are very important to a piping system, because they provide stability and anchor points for the pipe. Figure 21.50, page 897 shows a few



**SECTION D-D**  
(P-410)

(d)

FIGURE 21.47 (Continued)

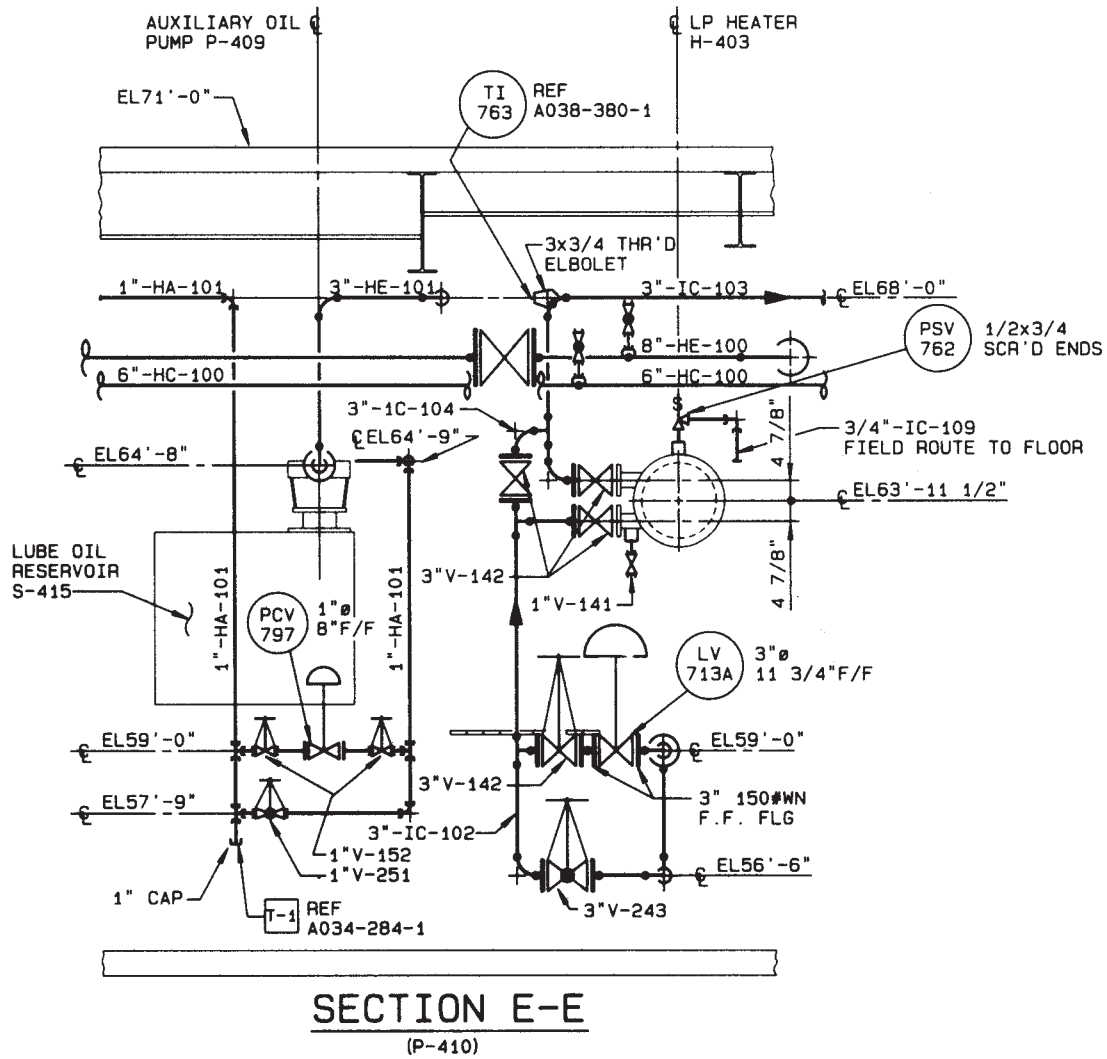
common pipe supports and hangers with their application in a sample piping system. If the hanger or support is complex or of a special design, it is often illustrated on a **detail drawing**, as shown in Figure 21.51. A symbol or note such as P.S. can indicate standard pipe clamps, anchors, hangers, and supports.

**Single-Line Drawings**

When drawings were done using manual drafting, a time-saving method of drawing pipe was the **single-line method**.

The centerline of the pipe represents the pipe when using the single-line method. The single-line technique can be used to better illustrate new pipe that is added to an existing installation or to show small-diameter pipe. Standard pipe symbols are used in single-line drawings, and the pipe and fittings are often drawn as heavy lines to provide contrast with other lines on the drawing.

Single-line drawings are no longer as common with the advent of CADD. Many companies only draw piping as single-line when they are threaded or socket weld, which is referred to as **small bore piping**. Most companies create the entire drawing



(e)

FIGURE 21.47 (Concluded)

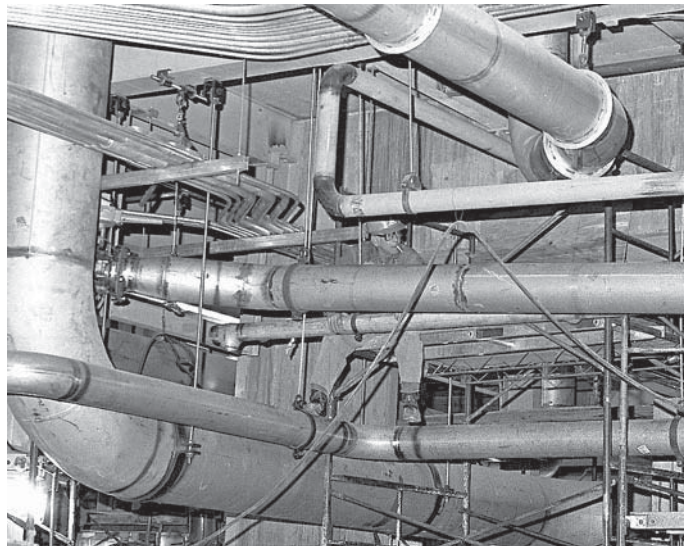
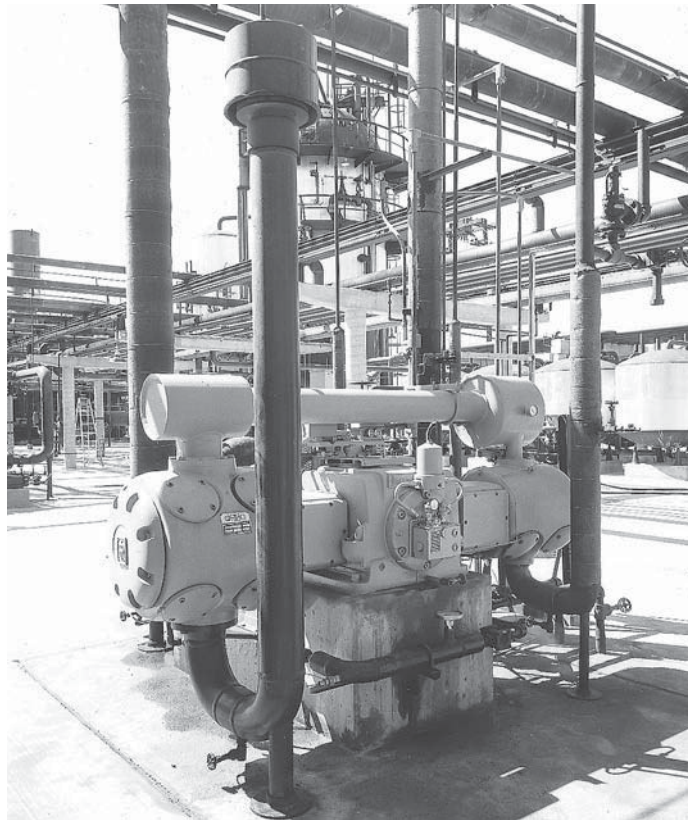


FIGURE 21.48 Pipe hangers are used to suspend pipe and conduit from the ceiling in this paper mill expansion project.

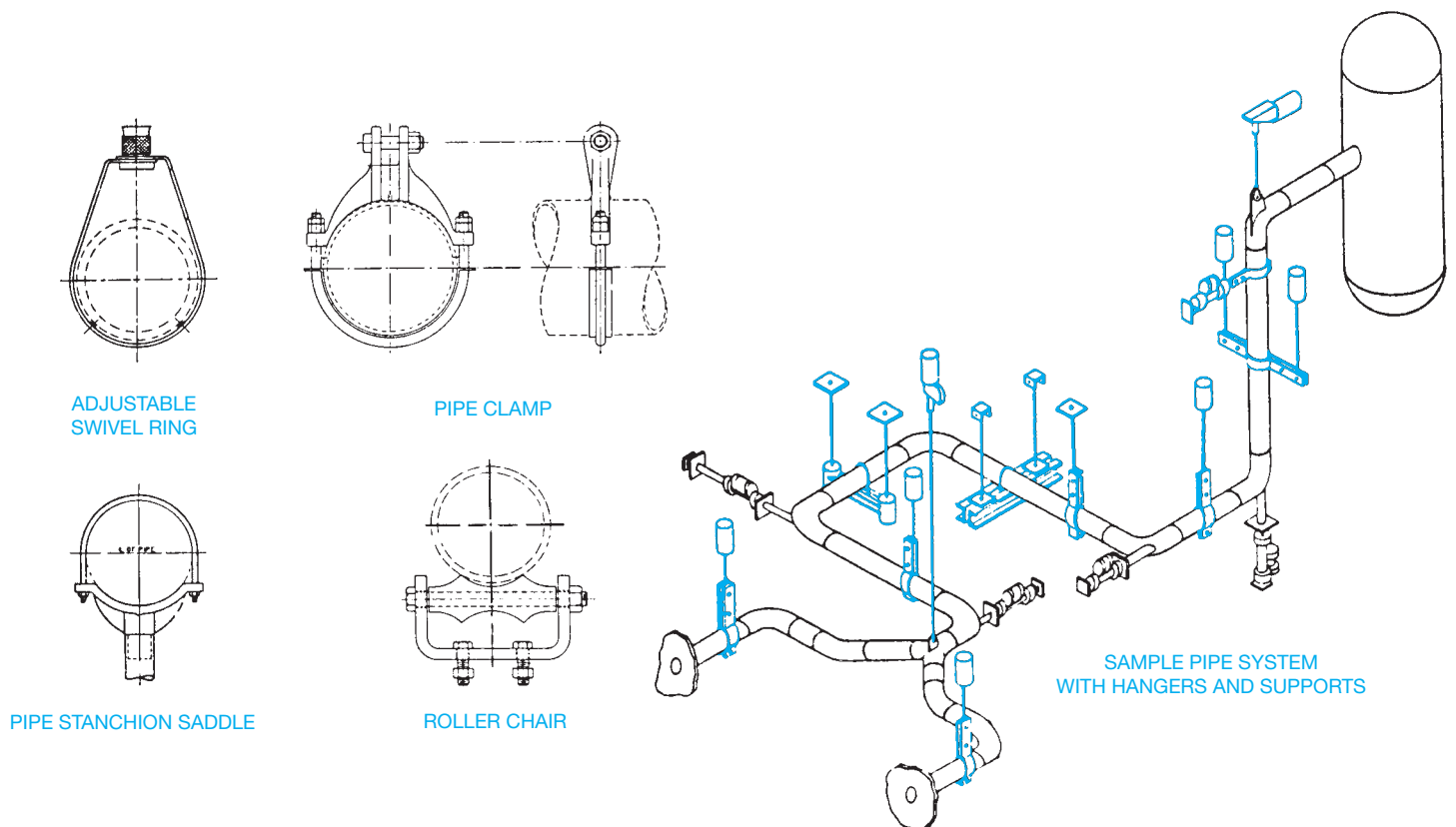
Courtesy Schuchart and Associates

© Cengage Learning 2012



Courtesy Ingersoll-Rand Company

**FIGURE 21.49** Pipe supports anchored to the ground are used on this air compressor piping at a chemical processing plant.



**FIGURE 21.50** Examples of common pipe hangers and supports. *Courtesy IIT Grinnell Corp.*



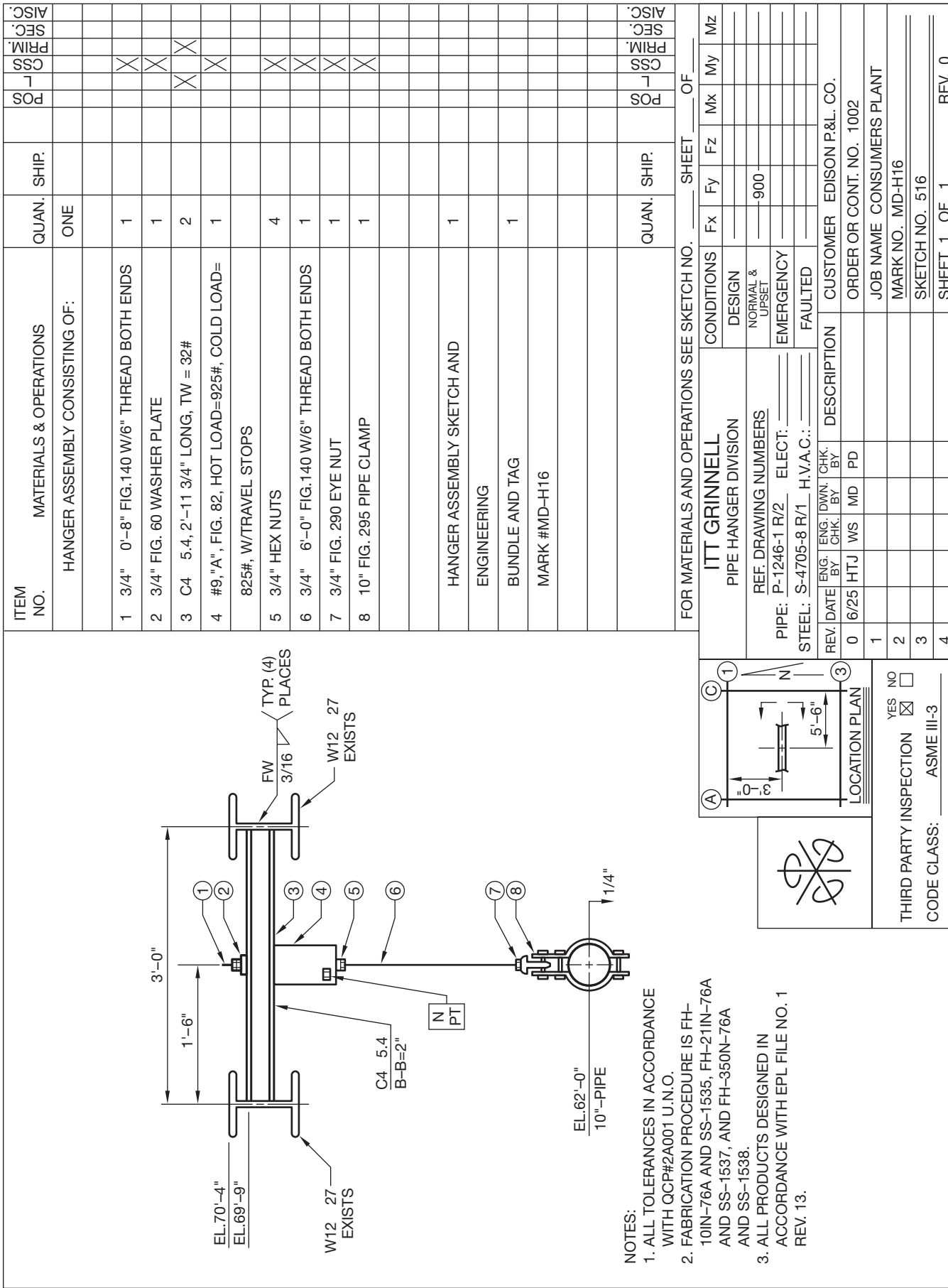


FIGURE 21.51 Detail of pipe hanger installation. Courtesy ITT Grinnell Corp.

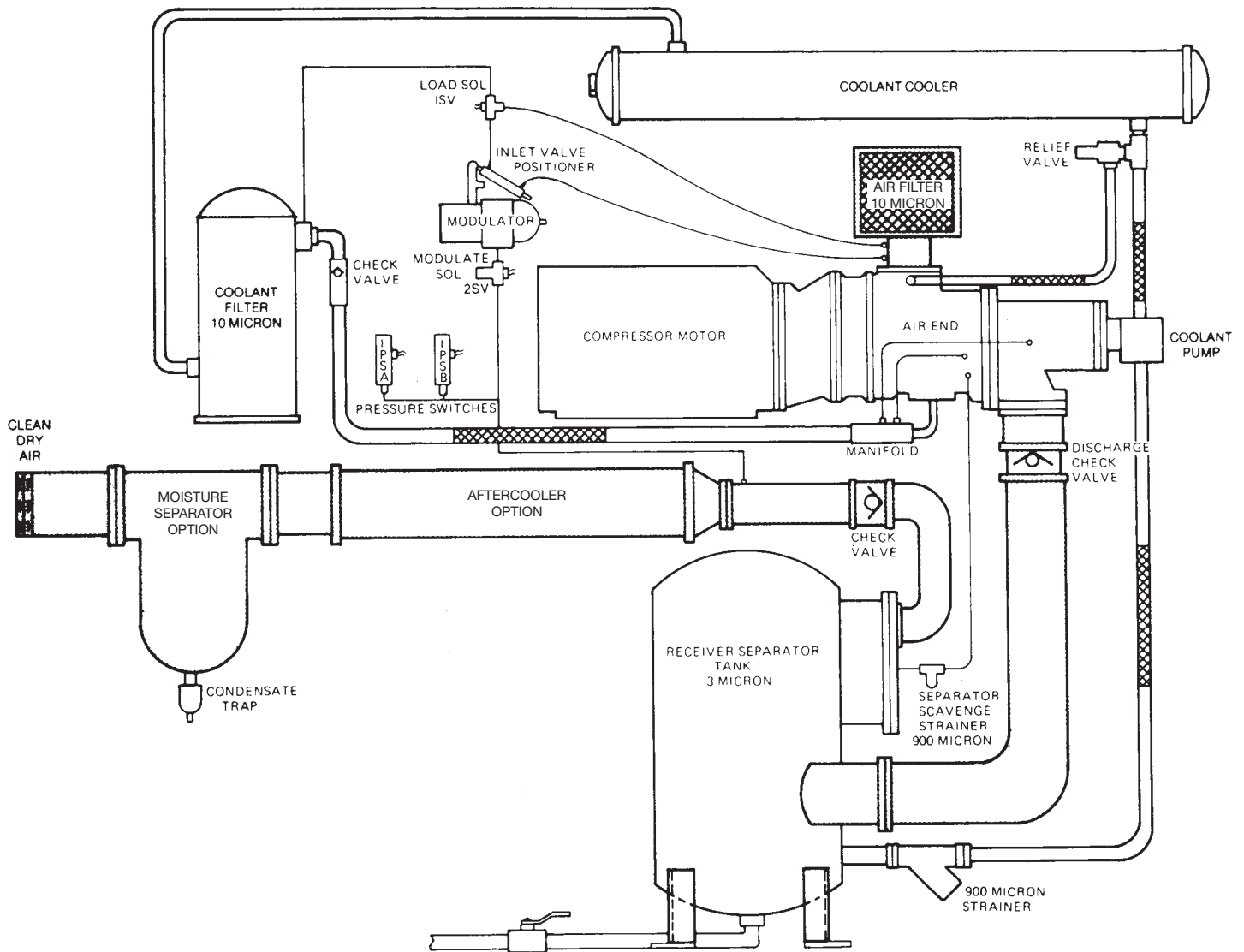


FIGURE 21.52 Manufacturer's double-line piping drawing of a compressed air system. Courtesy Ingersoll-Rand Company

using double-line drawing styles, because of the quality representation found in double-line drawings and the ease of drafting with CADD.

### Double-Line Drawings

The double-line method of drafting piping drawings is the easiest to interpret, because they look like the actual pipe. Double-line drawings are common in the piping industry because of CADD. The double-line method is the only practice used by equipment manufacturers to illustrate standard installation and presentation drawings (see Figure 21.52). The double-line method is also used to represent large diameter pipe and to show existing pipe at an industrial facility. The double-line method is also used for small views that are easily visualized as double-line drawings (see Figure 21.53). When new or small pipe is shown in the single-line method on the same drawing,

the contrast between the two styles aids in interpretation. The single-line method is seldom used for large-diameter pipe because clearances, interferences, spacing, and distances are not as easily seen. Where these factors are critical, the double-line method is preferred. In addition, as previously explained, the piping industry is moving away from single-line drawings with the use of CADD.

When laying out single-line or double-line piping drawing, it is best to begin with background information such as building outlines or structural steel column reference points. From these points, the equipment locations can be determined. Centerlines are often used to represent pumps. Other large equipment must be drawn. Pipe centerline locations then must be determined. CADD drafters can use pipe centerline location lines of a different color layer or as tick marks on the screen and then insert fittings and draw pipe during the drawing layout process.

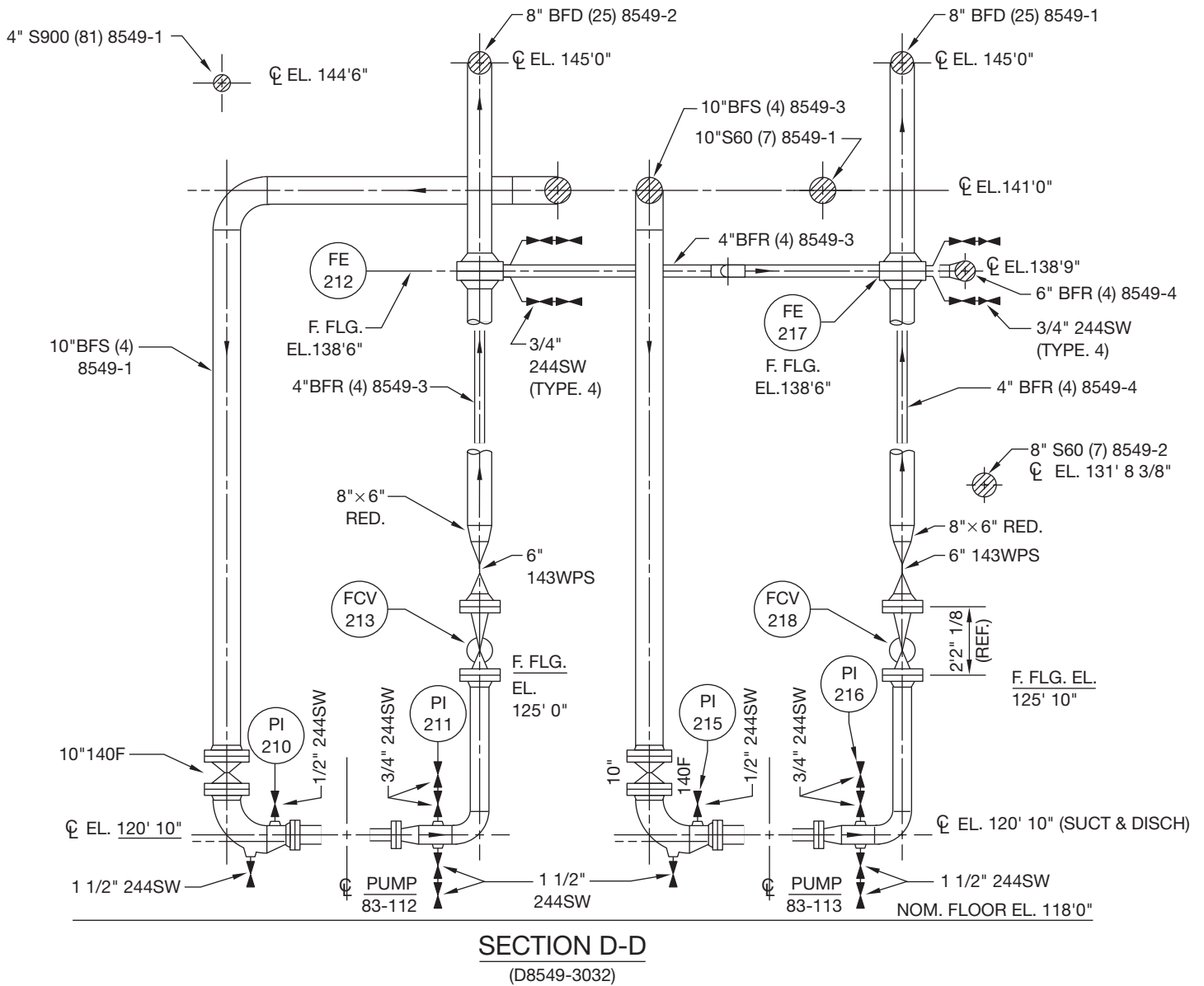


FIGURE 21.53 Sections from a typical double-line piping drawing. Courtesy Schuchart & Associates

## Fitting and Valve Symbols

Descriptions of piping fittings and valves were covered earlier in this chapter. A major portion of the piping drafters work is drawing fittings and valves. Pipe-fitting and valve symbols are shown in Figure 21.54.

**Symbols for Pipe Fittings and Valves**

For pipe fittings and valve symbols, go to the Student CD, select **CD Appendices**, and then **Appendix E**.

## Dimensions and Notes

**Dimensions** provide the measurements used for construction. Dimensions are presented using lines, numerical values, and symbols or notes and specifications. Drawings must have all the dimensions needed for construction so that workers do not have to guess about the size and location of features.

The dimensioning system most commonly used in pipe drafting is the same system used in architectural drafting and is known as **aligned dimensioning**. With this system, dimensions are placed in line with the dimension lines and read from the bottom or right side of the sheet. Dimension numerals are typically centered on and placed above the solid **dimension lines**

## PIPING SYMBOLS AND DETAILS

Most piping drawings involve the use of symbols. A productive part of your job is the use and placement of standard piping symbols and shapes on new drawings. Symbols need to be drawn only once, saved in a symbol library, and displayed in a menu. When a symbol is needed, it is picked from the menu, placed on the drawing, and scaled or rotated as needed. If your CADD system does not have a piping symbol library, it will save you time in the future if you begin to create one as soon as possible. Many commercially available packages contain piping symbol libraries

and have other automated features such as automatic bill of material creations.

Many symbol programs are intelligent, which means they contain pieces of information called *attributes* or *tags* that give meaning to the symbol. For example, a valve symbol can contain hidden attributes pertaining to its diameter, pressure rating, material, operating mechanism, style, weight, price, and manufacturer. When the valve symbol is used on a drawing, all of the attributes become a part of the drawing database. Figure 21.54a shows typical piping symbols. Figure 21.54b shows commonly used valves and **valve actuator** symbols. Valve actuators are the mechanisms that

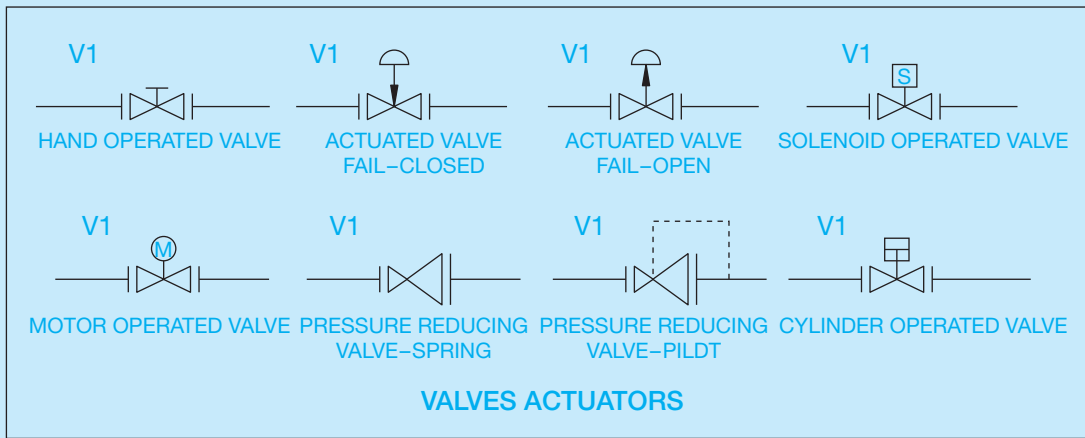
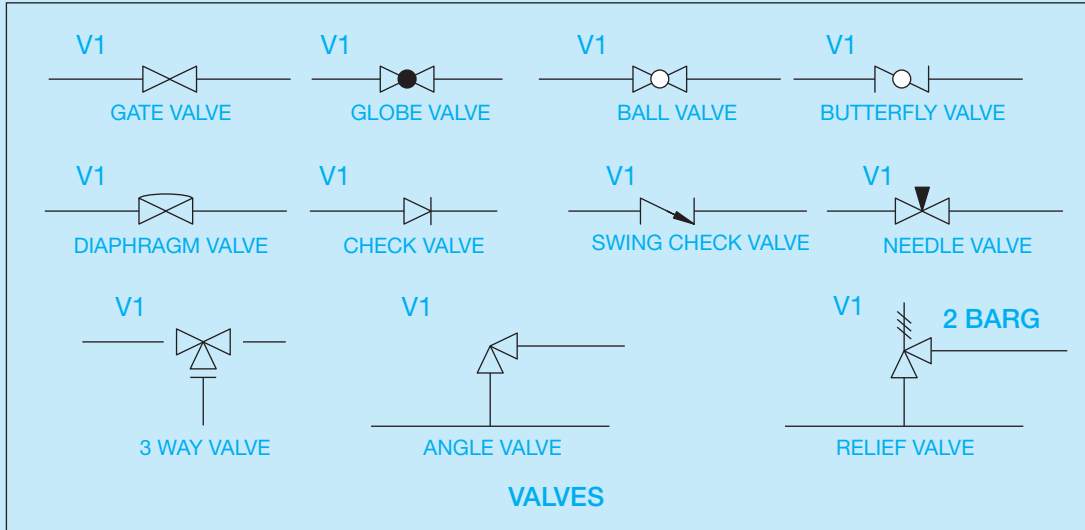


FIGURE 21.54 Typical pipe support symbols. (a) Common piping symbols.

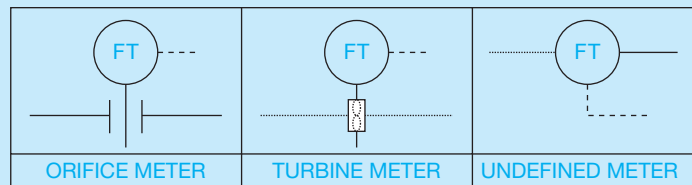
(Continued)

activate process control equipment. Figure 21.54c shows typical transmitter symbols. Transmitters function in a P&ID by allowing the control task to be completed in a process. Figure 21.54d shows examples of process piping

equipment symbols. Figure 21.54e shows standard line-fitting symbols. Figure 21.54f shows typical pipe support symbols. Figure 21.54g shows commonly used instrumentation, function, valve body, damper, and actuator symbols.



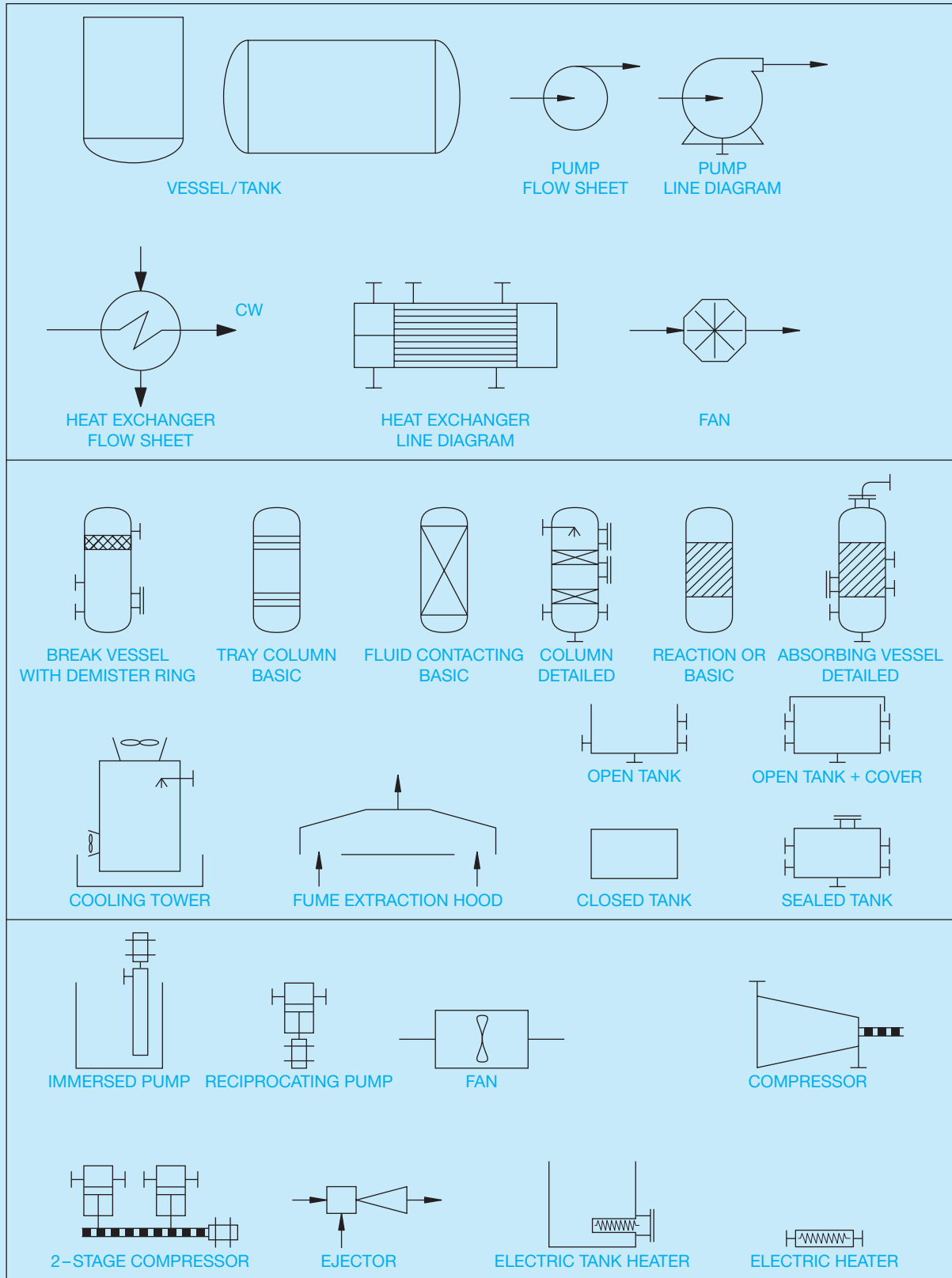
(b)



(c)

**FIGURE 21.54** (Continued) (b) Commonly used valves and valve actuator symbols. (c) Typical transmitter symbols.

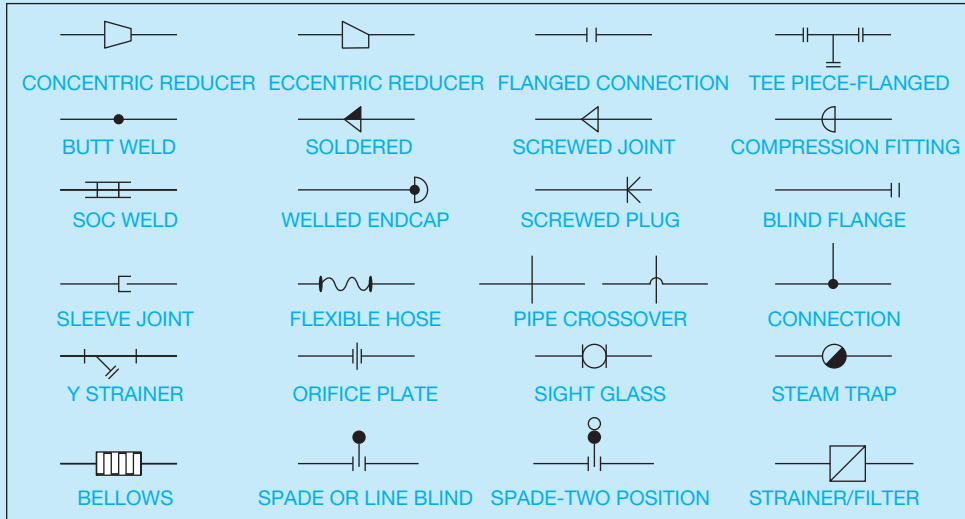
(Continued)



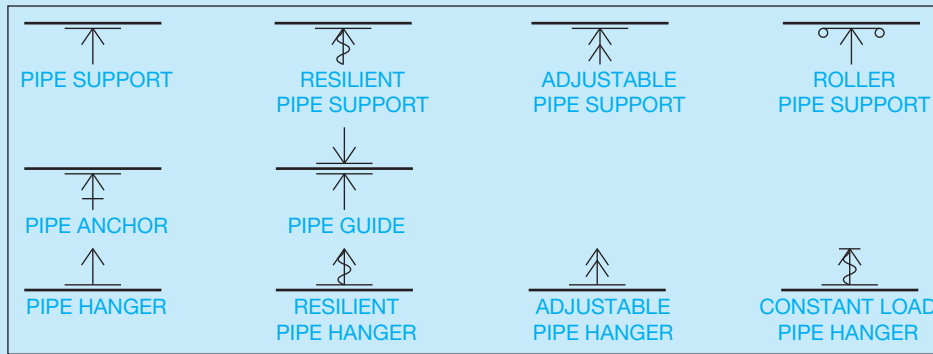
(d)

FIGURE 21.54 (Continued) (d) Examples of process piping equipment symbols.

(Continued)



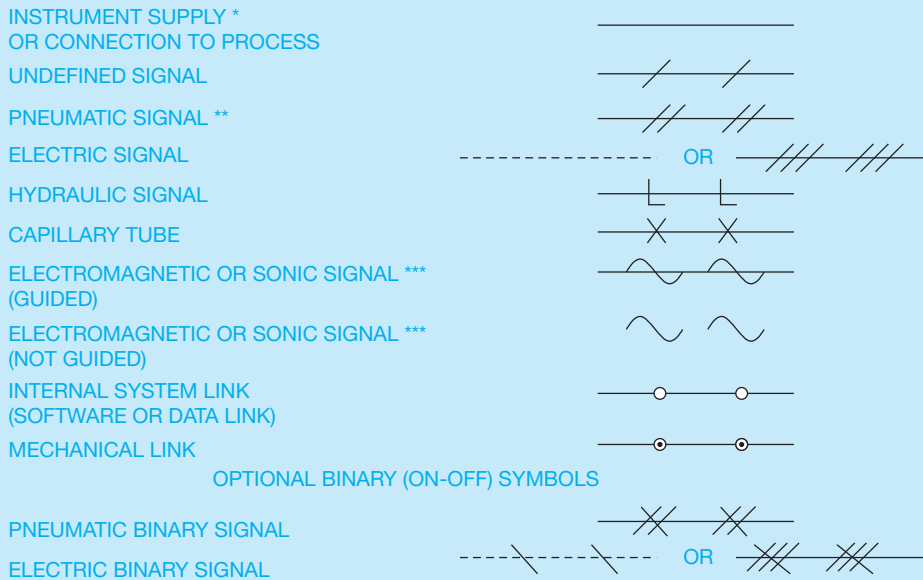
(e)



(f)

**INSTRUMENT LINE SYMBOLS**













ALL LINES TO BE FINE IN RELATION TO PROCESS PIPING LINES.











(g)

**FIGURE 21.54** (Continued) (e) Standard line-fitting symbols. (f) Typical pipe support symbols. (g) Commonly used instrumentation, function, valve body, damper, and actuator symbols.

(Continued)

	PRIMARY LOCATION	FIELD MOUNTED	AUXILIARY LOCATION
DISCRETE INSTRUMENTS	*  IP1**		
SHARED DISPLAY, SHARED CONTROL			
COMPUTER FUNCTION			
PROGRAMMABLE LOGIC CONTROL			

**GENERAL INSTRUMENT OR FUNCTION SYMBOLS**

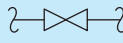



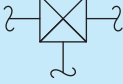
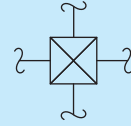


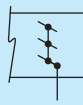
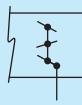
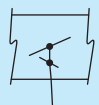
	 INSTRUMENT WITH LONG TAG NUMBER	 INSTRUMENT SHARING COMMON HOUSING*
 PILOT LIGHT	 PANEL MOUNTED PATCHBOARD POINT 12	 ** PURGE OR FLUSHING DEVICE
 ** REST FOR LATCH-TYPE ACTUATOR	 DIAPHRAGM SEAL	 ** *** UNDEFINED INTERLOCK LOGIC

**GENERAL INSTRUMENT OR FUNCTION SYMBOLS (CONTD.)**



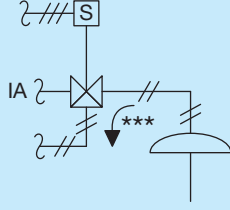
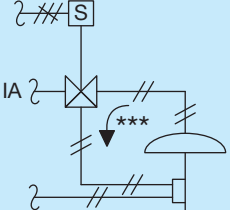
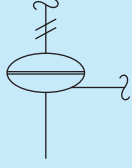
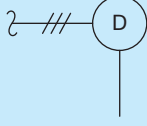
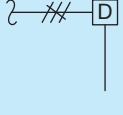
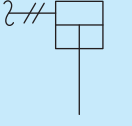
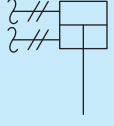
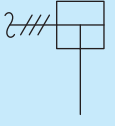
**FIGURE 21.54** (Continued) (h) General instrument or function symbols.

(Continued)



 GENERAL SYMBOL	 ANGLE	 BUTTERFLY	 ROTARY VALVE
 THREE-WAY	 FOUR-WAY	 GLOBE	
 DIAPHRAGM			
		DAMPER OR LOUVER	

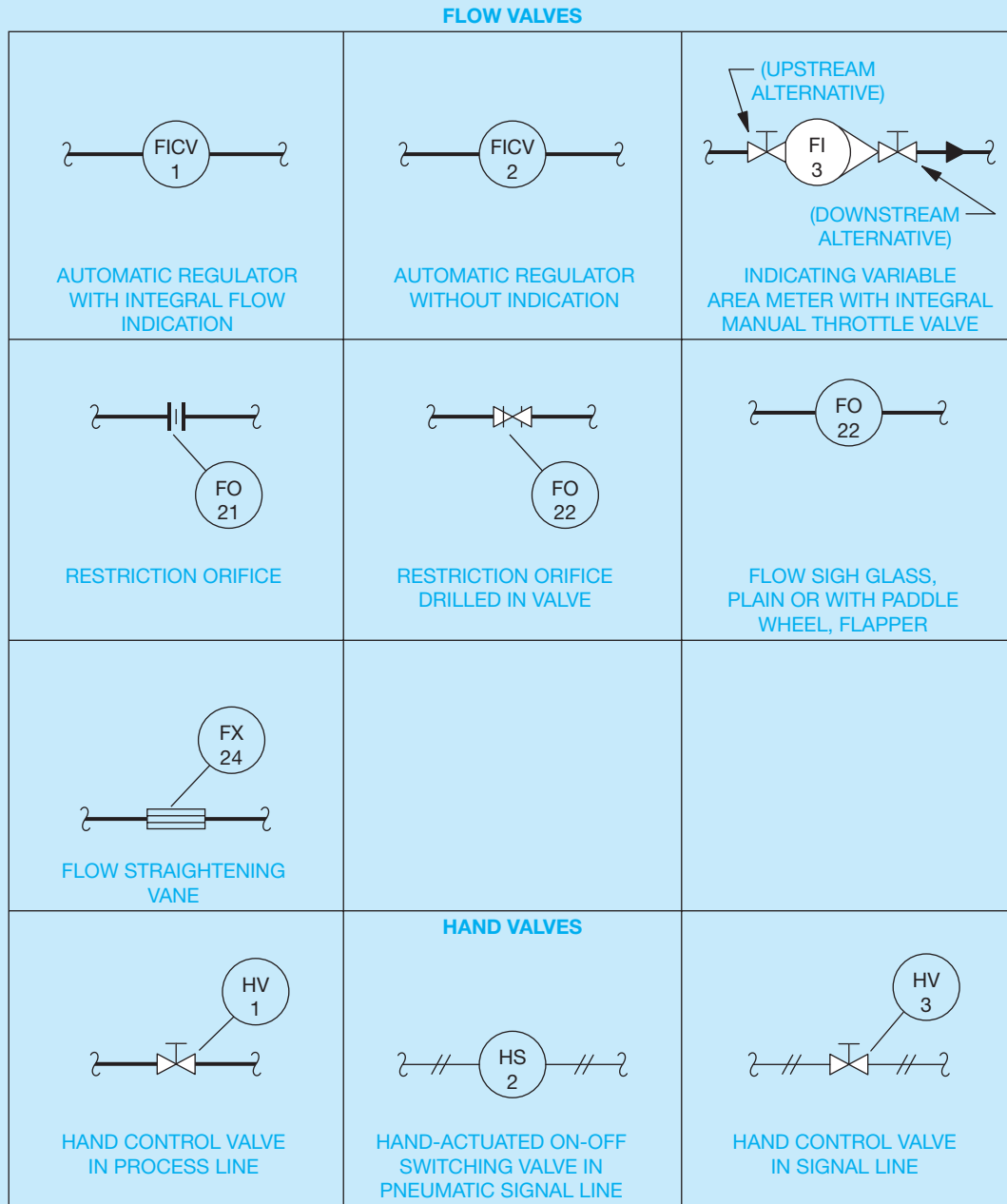
CONTROL VALVE BODY SYMBOLS, DAMPER SYMBOLS  
(i)

 WITH OR WITHOUT POSITIONER OR OTHER PILOT	 PREFERRED FOR DIAPHRAGM ASSEMBLED WITH PILOT	 PREFERRED ALTERNATIVE	 OPTIONAL ALTERNATIVE
DIAPHRAGM, SPRING-OPOSED OR UNSPECIFIED ACTUATOR		DIAPHRAGM, SPRING-OPOSED, WITH POSITIONER	
 DIAPHRAGM, PRESSURE-BALANCED	 ROTARY MOTOR (SHOWN TYPICALLY WITH ELECTRIC SIGNAL. MAY BE HYDRAULIC OR PNEUMATIC)	 DIGITAL	
 SPRING-OPOSED SINGLE-ACTING	 DOUBLE-ACTING	 PREFERRED FOR ANY CYLINDER THAT IS ASSEMBLED WITH A PILOT	
CYLINDER, WITHOUT POSITIONER OR OTHER PILOT			

(j)

FIGURE 21.54 (Continued) (i) Control valve body and damper symbols. (j) Diaphragm symbols.

(Continued)



(k)

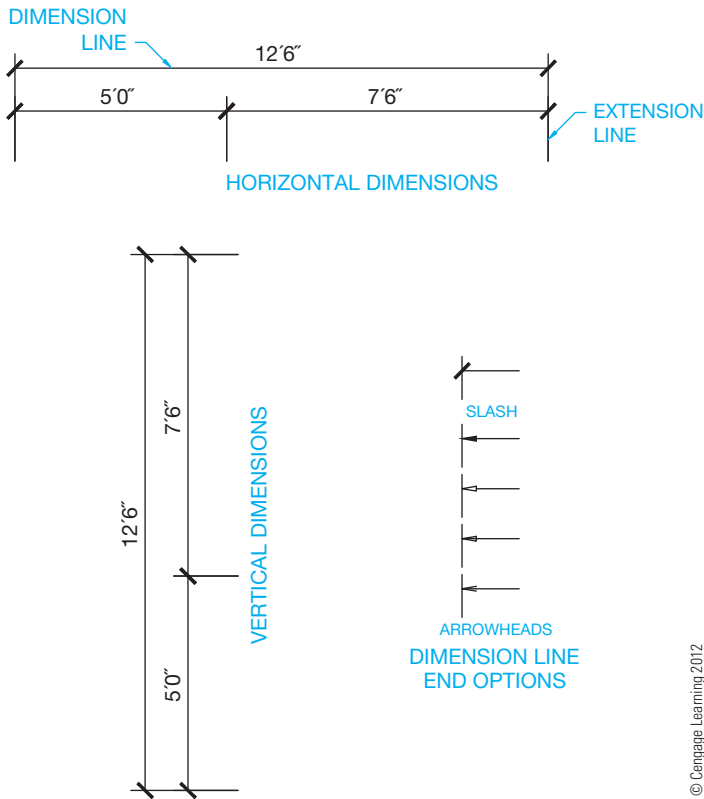
FIGURE 21.54 (Concluded) (k) Flow valve symbols.

**STANDARDS**

**ANSI/ISA** The ANSI and the International Society of Automation (ISA) document ANSI/ISA 5.1, *Instrumentation Symbols and Identification*, is a source for a variety of instrumentation symbols shown in Figure 21.54g. The ISA is an organization of engineers, technicians, and others who work in the field of instrumentation, measurement, and control of industrial processes. For more information or to order standards, go to the ISA Web site at [www.isa.org](http://www.isa.org).

Drafters using CADD systems should keep an easily accessible up-to-date record of all piping details. Piping details are often needed again on the same project or on another project. Placing an entire detail on a drawing instead of constructing the detail again saves significant time. An individual detail may not be the same as a previous one, but even revising an existing detail is much quicker than redrawing.

© Cengage Learning 2012



**FIGURE 21.55** The dimensioning system most commonly used in pipe drafting is aligned dimensioning. With this system, dimensions are placed in line with the dimension lines and read from the bottom or right side of the sheet. Dimension numerals are typically centered on and placed above the solid dimension lines. Dimension line ends are normally slashes or arrowheads.

(see Figure 21.55). A dimension line is a thin line showing the length of the dimension that terminates at the related **extension lines**. Extension lines are thin lines showing the extent of the dimension, starting with a small space from the feature being dimensioned and extending past the last dimension line.

You should place dimensions so the drawing does not appear crowded. However, this is often difficult because of the great amount of content that must appear on a piping drawing. When placing dimensions, space dimension lines a minimum of 3/8" (10 mm) from the object and from each other. If there is room, 1/2" (13 mm) to 1" (26 mm) is preferred. Confirm the recommended dimension line spacing with your office or instructional standards. Regardless of the selected dimension line distance, be consistent so dimension lines are evenly spaced and uniform throughout the drawing. Use a recommended 1/16" (1.5 mm) space between the start of the extension line and feature being dimensioned. Extension lines extend 1/8" (3 mm) past the last dimension line.

Dimension lines terminate at extension lines with dots, arrowheads, or slash marks that are each drawn in the same direction (see Figure 21.55). The U.S. National CAD Standard recommends slash marks or filled arrowheads. The type of dimension line terminators should be the same throughout the drawing, although slash marks are common on dimension line

terminators and filled arrowheads are used on leaders for notes as described later in this chapter.

Dimension numerals are drawn 1/8" (3 mm) high and are centered above the dimension line with a 1/16" (1.5 mm) space between the dimension line and the value. The dimension units used are feet and inches for all lengths over 12". Inches and fractions are used for units less than 12". Foot units are followed by the symbol ', and inch units are shown by the symbol ". The dash can be used or omitted, for example, 14'-6" or 14'6".

## Metric Dimensions

The millimeter (mm) is the unit of measure commonly used on metric drawings. Meters (m) are used for large site plans and civil engineering drawings. Metric dimensioning is based on the International System of Units (SI). Metric sizes vary, depending on **hard** or **soft conversion**.

A **soft metric conversion** is the preferred metric construction standard that rounds off dimensions to convenient metric modules. For example, in soft conversion, 36" equals 900 mm. Inches are converted to millimeters with the formula  $25.4 \times \text{inches} = \text{mm}$ . So  $25.4 \times 36" = 914.4 \text{ mm}$ . This is rounded off using soft conversion to 900 mm, because 900 is an even-metric module commonly used in construction. Soft conversion is the preferred method of metric dimensioning as previously described. In countries using metric measurement, the dimensioning module is 100 mm.

A hard metric conversion is calculated close to or the same as the inch equivalent. A hard conversion of 36" is  $25.4 \times 36" = 914.4$ , which is rounded off to 914 mm. This formula is appropriate in a situation where the code requires exact metric values. When materials are purchased from the United States, it is often necessary to make a hard conversion to metric units.

Although piping drawings normally are dimensioned in a style similar to architectural drawings, some companies use the mechanical style with dimension values placed in a break in the dimension lines. Refer to the plan in Figure 21.47a for examples of piping plan dimensions.

## Expressing Metric Units on a Drawing

When placing metric dimensions on a drawing, all dimensions specified with dimension lines are in millimeters and the millimeter symbol (mm) is omitted. When more than one dimension is quoted, the millimeter symbol is placed only after the last dimension—for example, 1200 × 2400 mm. The millimeter symbol is omitted in the notes associated with a drawing, except when referring to a single dimension such as the thickness of material or the spacing of members. For example, a note might read 90 × 1200 BEAM without using mm, while the reference to material thickness of 12 mm or the construction member spacing of 400 mm on center (OC or O.C.) places the millimeter symbol after the size.

## Rules for Writing Metric Symbols and Names

The following is a list of rules for writing metric symbols and names:

- Unit names are lowercase, even those derived from proper names—for example, millimeter, meter, kilogram, kelvin, newton, and pascal. Use vertical text for unit symbols. Use lowercase text, such as mm (millimeter), m (meter), and kg (kilogram), unless the unit name is derived from a proper name as in K (Kelvin), N (Newton), or Pa (Pascal).
- Use lowercase for values less than 10<sup>3</sup> and use uppercase for values greater than 10<sup>3</sup>.
- Leave a space between a numeral and symbol, such as 55 kg, 24 m. Do not close the space like this: 55kg, 24m.
- Do not leave a space between a unit symbol and its prefix—for example, use kg, not k g.
- Do not use the plural of unit symbols—for example, use 55 kg, not 55 kgs.
- The plural of a metric name should be used, such as 125 meters.
- Do not mix unit names and symbols; use one or the other. Symbols are preferred on drawings where necessary. Millimeters (mm) are assumed on architectural drawings unless otherwise specified.

### Metrics in Piping

Pipe is made of a wide variety of materials identified by trade names, with nominal sizes related only loosely to actual dimensions. For example, a 2" galvanized pipe has an inside diameter of about 2 1/8" but is called 2" pipe for convenience. Because few pipe products have even inch dimensions that match their specifications, there is no reason to establish even metric sizes. Metric values established by the International Organization for Standardization (ISO) relate nominal pipe sizes (NPS) in inches to metric equivalents, referred to as **diameter nominal (DN)**. The following equivalents relate to all plumbing, natural gas, heating, oil, drainage, and miscellaneous piping used in buildings and civil engineering projects:

NPS (IN)	DN (mm)	NPS (IN)	DN (mm)
1/8	6	8	200
3/16	7	10	250
1/4	8	12	300
3/8	10	14	350
1/2	15	16	400
5/8	20	20	450
3/4	20	20	500
1	25	24	600
1 1/4	32	28	700
1 1/2	40	30	750
2	50	42	800
2 1/2	65	36	900
3	80	40	1000
3 1/2	90	44	1100
4	100	48	1200
4 1/2	115	52	1300
5	125	56	1400
6	150	60	1500

The standard threads for threaded pipe are the National Standard taper pipe threads (NPT). The thread on 1/2" pipe reads 1/2–14NPT, where 14 is the number of threads per inch. The metric conversion affects only the nominal pipe size—1/2 in this case. The conversion of the 1/2–14NPT pipe thread to metric is 15–14NPT.

### Piping Elevations and Sections

**Piping elevations** or **sections** are not normally dimensioned the same as plan views. Instead of linear dimensions, elevation values are used. Occasionally, elevations for the **bottom of the pipe (BOP)** are required. The sections found in Figures 21.47b–e show the use of elevations to call out the centerlines of pipes and elevations to the **top of concrete (TOC)** or **top of steel (TOS)**.

Lay out dimensions before any other written information is added to the drawing, because it is normally easier to place notes and other content around dimensions. Specified pipe lengths and dimensions to pipe direction changes should be given from reference points such as equipment and structural steel centerlines. Location dimensions of fittings, flanges, and valves should be given to center points or flange faces if needed. Pipe fittings and valves that are attached without pipe between them are often left undimensioned. This application is called **fitting-to-fitting**. The actual fitting-to-fitting location is the result of the combined fitting lengths and does not vary.

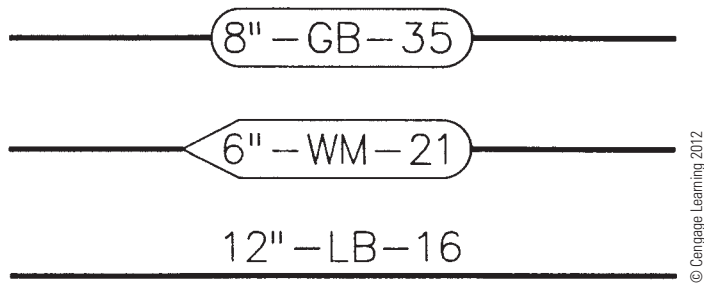
Dimension lines are important and should not be broken if passing through other lines. Pipes, equipment, or extension lines that must pass through dimension lines should be broken, and the dimension line should remain unbroken.

Once dimension lines have been placed on the drawing, local notes and callouts can be given. Local notes and callouts should be placed close to where they apply without crowding other objects or creating a confused layout. Try to group local notes together when possible. This allows people reading the drawing to find similar information without much searching.

Pipe specification numbers can be written near the pipe and connected to the pipe with a leader line, or the numbers can be placed inside a symbol called a **line balloon**. The line balloon is either rounded or squared on the ends and is 1/4" wide and approximately 1" long (6–25 mm). The preferred location for the line balloon is inside the pipe, but it can be placed outside the pipe and used with a leader line if space is limited inside the pipe. Figure 21.56, page 910, shows examples of pipe specification numbers.

When checking your drawing, be sure all of the following items are provided:

- Pipe length dimensions.
- Dimension locations of all pipe direction changes.
- Locations of all fittings and valves if required.
- Elevation location of all pipe direction changes in section views.



© Cengage Learning 2012

**FIGURE 21.56** Methods of indicating pipeline specifications.

- Size and type of valves.
- Size and type of fittings (if not readily identified).
- Pipe diameter, contents, and identification number.
- Pipe flow arrows.
- Equipment names and numbers.

## PIPING DETAILS

A **pipng detail** drawing can be drawn for any connection, application, or installation that cannot be readily distinguished from the other piping drawings. Common piping detail drawings are used for the following applications:

- Special pipe connections or fittings.
- Special valve arrangements.
- Small-diameter pipe and fitting assemblies.
- Special pipe support arrangements.
- Tank attachment details.
- Minor structural alterations (concrete, wood, and steel).
- Operating and installation procedures.

The engineers and drafters on the project must determine when piping details are needed and if they are to be drawn in 2-D or 3-D. Figure 21.57, page 911, shows common piping details.

## Piping Isometric and Spool Drawings

A **pipng isometric drawing** is a pictorial view of a piping system representing fittings, valves, dimensions, notes, and instrumentation. This single view of the piping system eliminates the need for additional views. A piping isometric drawing is often done after the plans and elevations are completed.

Refer to Chapter 14, *Pictorial Drawings and Technical Illustrations*, for detailed information. There are many advantages of a piping isometric drawing. For example, a single run of pipe from beginning to end can be shown in one view and is more easily visualized than corresponding 2-D views. Piping

drafters **never** draw piping isometrics to scale. If an isometric is not drawn to scale, it eliminates the need for large sheets and is most often drawn on B-size (A3-size) media. Dimensions are given on the isometric view, and straight lengths of pipe are drawn proportionally to indicate long and short pieces as shown in Figure 21.58, pages 912–913.

A bill of materials is often included on the piping isometric, which allows the pipe fitter, checker, and purchasing agent to cross-check the drawing with a list of the materials required.

Some companies illustrate a piping system or portions of a piping system in a pictorial drawing for purposes of orientation, training, assembly, and installation. CADD systems are available that allow companies to create complete isometric drawings automatically from plan drawings or to create pictorial modeled systems as shown in Figure 21.59.

Piping systems are constructed by **pipe fitters**, or welders, who must initially weld or thread pipe fittings and pipe together to create pipe **spools**. Figure 21.60, page 913 shows a pipe fitter welding a pipe joint. Pipe fitters work from assembly instructions called **spool drawings**, **spools**, or **spool sheets**. Spools are also called **pipe assemblies**. Spool drawings are 2-D or 3-D and show the pipe and fittings needed to assemble a segment of piping. The spools are then transported to the job site and installed. Figure 21.61 shows pipe spools awaiting installation.

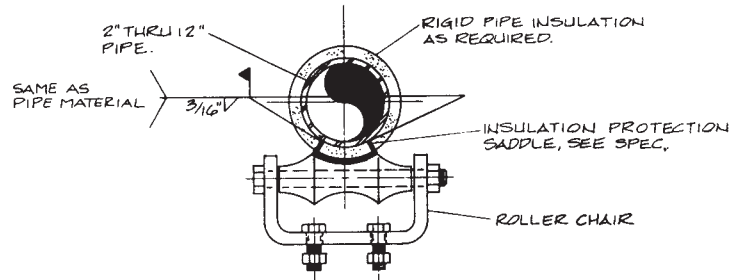
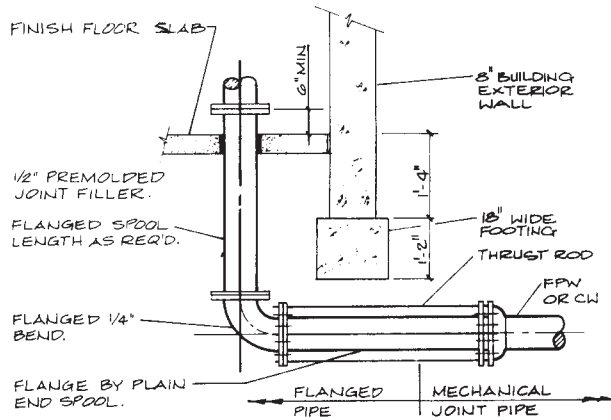
Pipe spools are often on a B-size (A3-size) sheet and may or may not be drawn to scale (look back to Figure 21.13, page 875). **Spool sheets** are assembly drawings that contain complete dimensions and a **bill of materials (BOM)** that indicates the exact size and specifications for each fitting. Extra pipe is usually added to pipe lengths to compensate for errors. A 2-D spool drawing only shows the views required to present the lengths of straight pipe and fittings. Valves are never shown on spool drawings because they are installed at the job site when the spools are erected.

## Models

Physical piping models are rarely used in industry anymore, although you can still find them on display at some companies (see Figure 21.62, page 914). One of the greatest advantages of a physical piping model was the ability to see clearances and interferences easily. The construction of a physical model can take months to complete, making it impossible to ship to the job site during most of the construction phases. Photos of the model can be used at the job site for checking purposes. Drawings of the system must still be generated for use in construction.

## DRAWING SHEETS

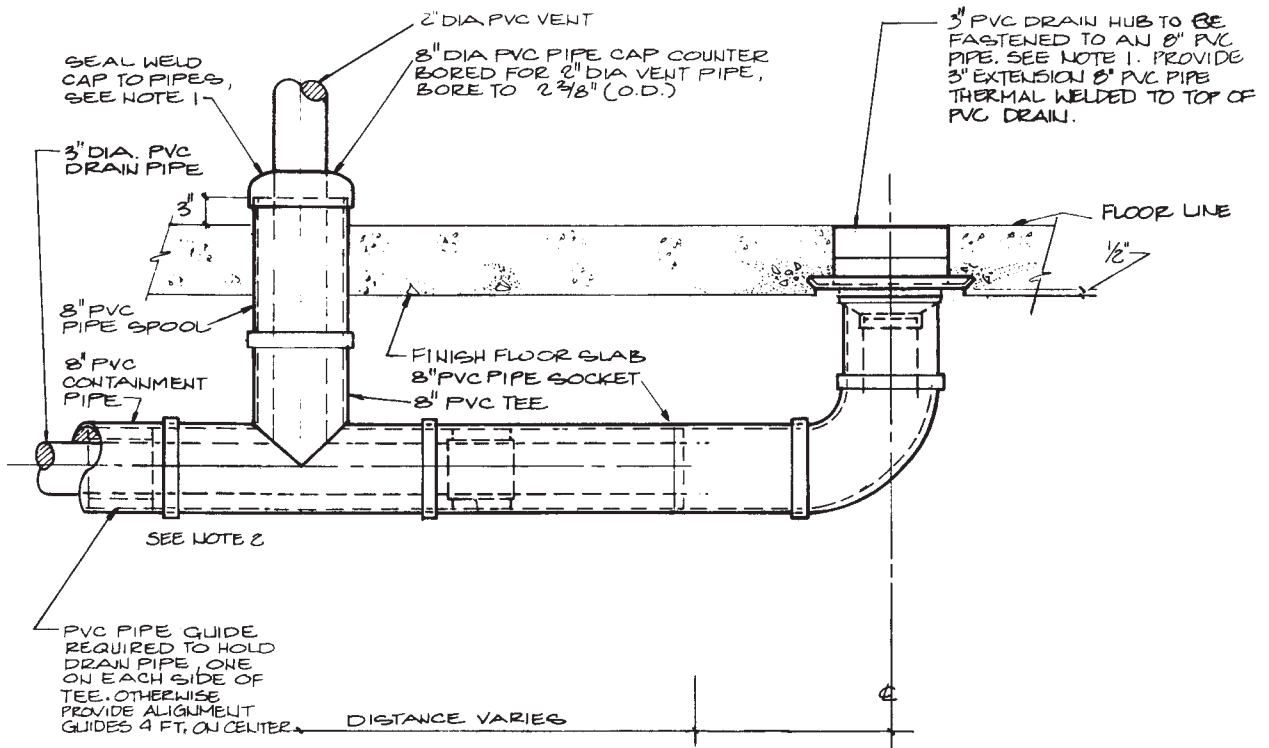
Drawing sheets used for pipe drafting are commonly the large sheet format also used for architectural, mechanical, and structural drawings. The E size 44 in. × 34 in. (A0 size, 1189 mm × 841 mm) sheet size is common, but other sheet sizes are also used. Most sheets have a border and title block,



NOTE:  
 1. SEE MECHANICAL DRAWINGS FOR LOCATIONS AND SIZES.  
 2. SEE FOUNDATION DRAWINGS FOR ANY DIFFERENCES IN FOOTING DEPTHS.

**5** ROLLERCHAIR PIPE SUPPORT (c)

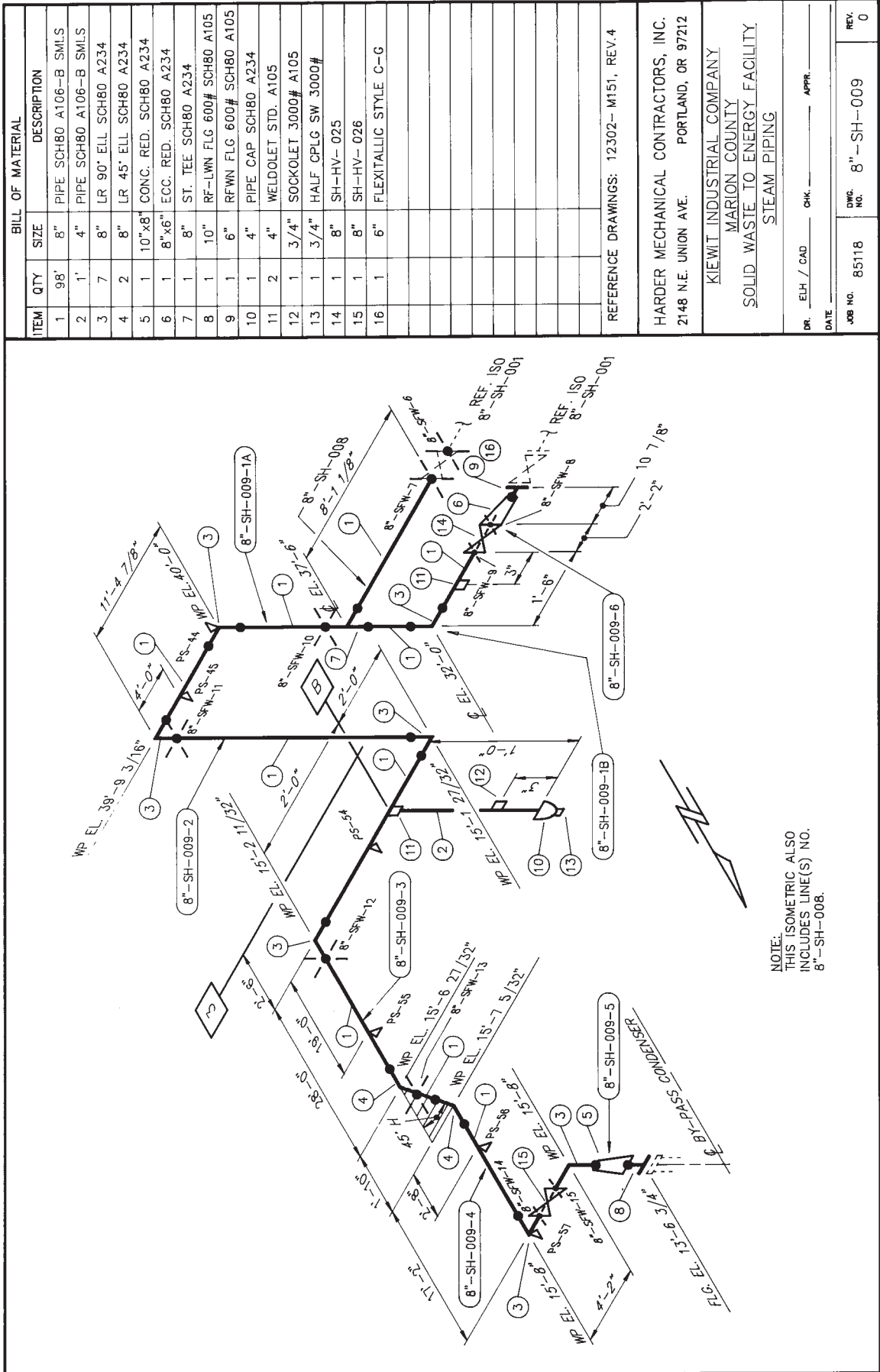
**8** THRUST TIE (a)



NOTES:  
 1. THERMAL WELD ALL SEAMS WHERE POSSIBLE.  
 2. TERMINATE 8\"/>

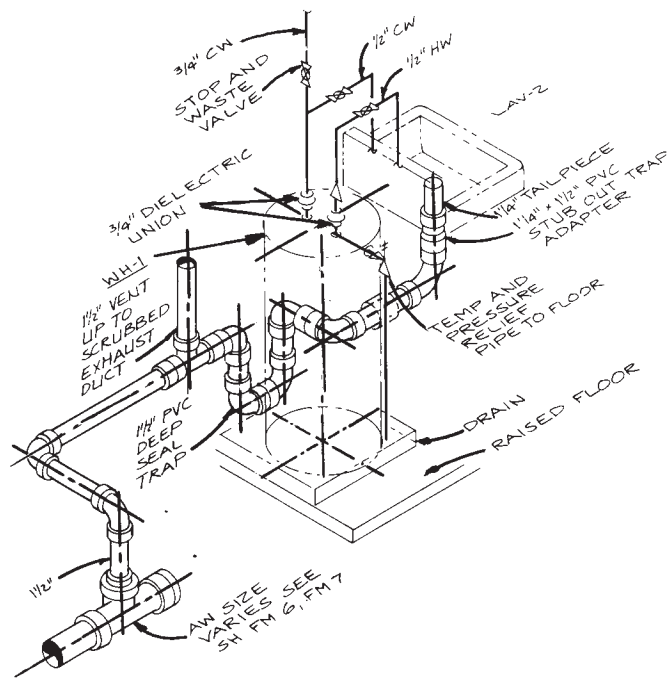
**12** DRAIN PIPING (b)

FIGURE 21.57 (a and b) Piping details of buried pipe. (c) Pipe hanger detail. Courtesy CH2M Hill - I.D.C.



(a)

FIGURE 21.58 (a) Piping isometric with nonscale proportional dimensioning. Contractors, Inc



DE-CONTAMINATION  
WASH SINK PIPING  
DETAIL (3)

(b)

FIGURE 21.58 (Continued) (b) Non-scale double-line piping isometric.



FIGURE 21.60 Pipe fitter welding a piping spool assembly. Courtesy Alaskan Copper Works

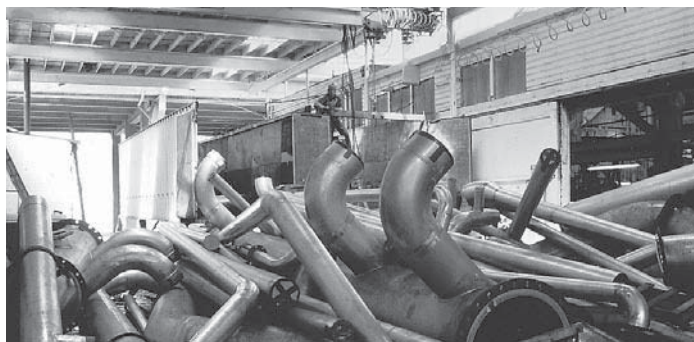


FIGURE 21.61 Assembled pipe spools awaiting installation. Courtesy Alaskan Copper Works

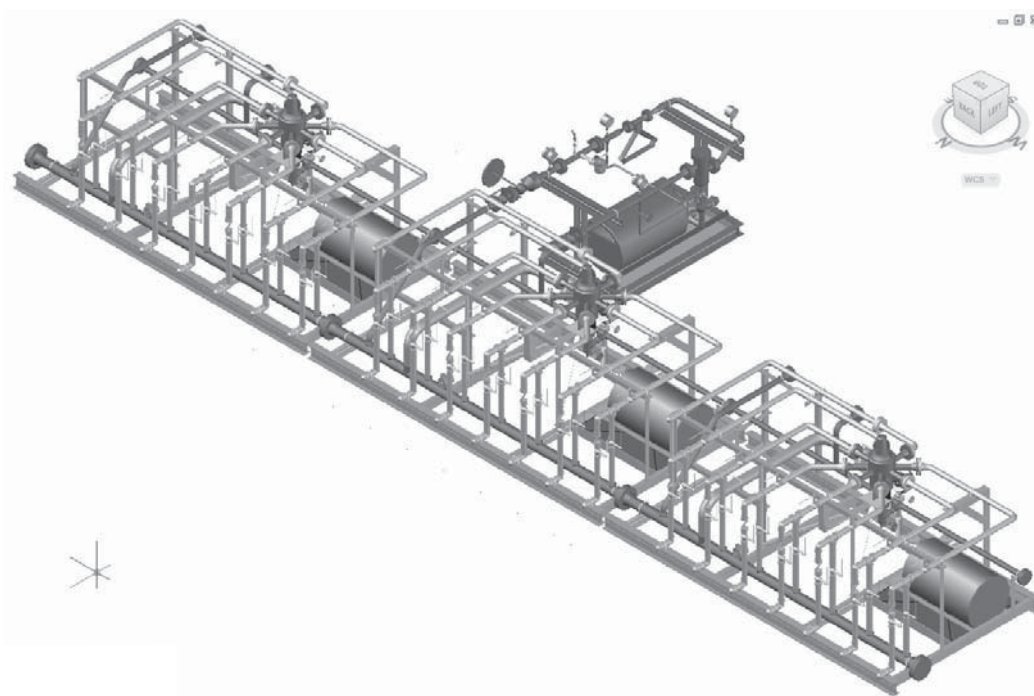
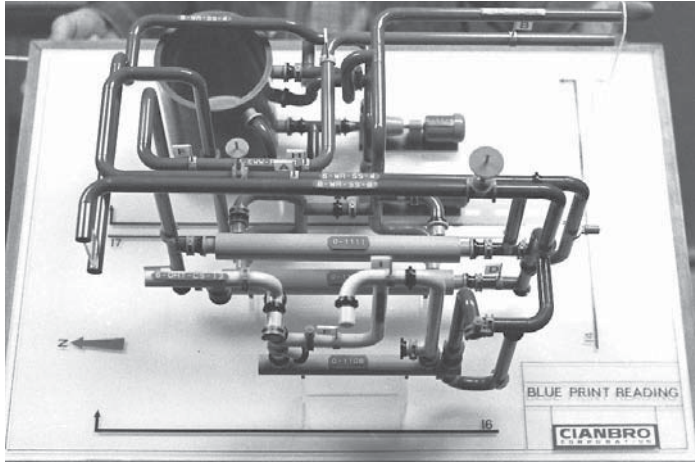


FIGURE 21.59 CADD systems are available that allow companies to create complete pictorial modeled systems as shown in this example.





**FIGURE 21.62** Piping models are good visualization tools that allow designers to easily check clearances. Models are also excellent teaching aids. Physical models like the one shown in this figure are still found on display at some companies. *Courtesy Engineering Model Associates, Inc.*

with the title block along the bottom or right side of the sheet (look ahead to Figure 21.66). Title block information can include content such as company name and logo, company address and phone number, revision history block, engineering stamp, customer name and project name, and sign-off signatures.

## DRAWING REVISIONS

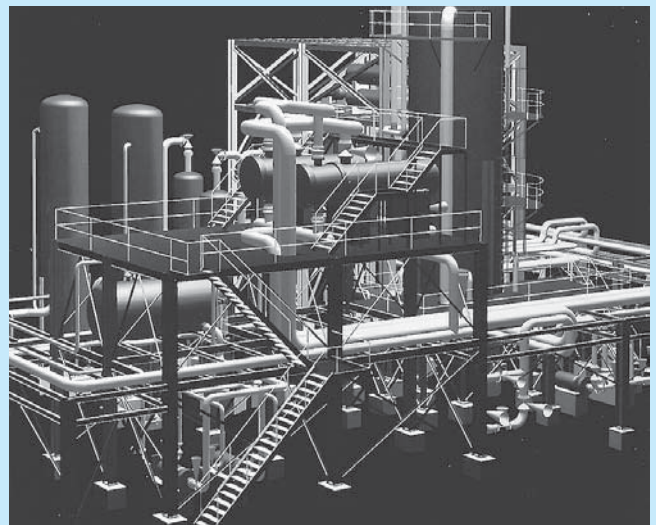
Drawing revisions are common in the architectural, structural, piping, and construction industries. Revisions occur for a number of reasons—for example, changes requested by the owner, job-site corrections, correcting errors, and code changes. Changes are done in a formal manner by submitting an **addendum** to the contract, which is a written notification of the change or changes that is accompanied by a drawing that represents the change.

## 3-D SYSTEM MODELS

CADD models have replaced physical models, because CADD models are easy to create and are used to generate the other drawings needed in the piping project automatically. Just like a physical model, one of the greatest advantages of a CADD model is the ability to see clearances and interferences easily. Information about interferences can be quickly transferred to the drawings, thus eliminating many errors that might occur if only drawings are used. Operators, maintenance technicians, and engineers can be trained on the workings of the system using the CADD model. Revisions, alterations, and design changes can be accomplished efficiently using the model to check for clearances and the addition of new equipment and piping locations.

CADD systems allow you to create a full-color 3-D model of the piping project. The model can be rotated to show any view of the project (see Figure 21.63). Hard-copy prints of any aspect of the piping system can be generated for use in the design or construction of the system.

A CADD model can be used to create 2-D and isometric drawings and to generate a BOM for the project automatically. This is a major step toward generating a single database for a construction project that is accessible to all personnel, owners, and clients. Once all the design information is in the system, any type of data can be requested in the form of plotted drawings, reports, tables, material lists, estimates, bills of material, and a variety of screen displays. As changes are made to the design, the changes are automatically updated in all data files.



**FIGURE 21.63** This 3-D model of a piping system has been shaded and rendered to achieve a realistic presentation.

Currently, product and industrial piping design and construction applications are handled completely on a computer system. This central system containing an extensive database that includes building or site sizes and construction codes is able to automatically route and lay out pipe, valves, fittings, and equipment. The computer performs the routine tasks, allowing more time for the overall design of the system by the engineer, technician, or design drafter. Knowledge of CADD and a continuing interest in computer and software advances helps the piping engineer, designer, and drafter to learn and change as the technology advances.

*(Continued)*

### 3-D DIGITIZING

3-D digitizers allow you to pick points on an object in order to input 3-D model data into CADD software (see Figure 21.64). This form of data input is called **reverse engineering (RE)** because the real part is used to construct a model. RE is the process of converting an existing physical product into drawings or digital models, and it involves discovering the technological principles of a device, object, or system through analysis of its structure, function, and operation. RE often involves disassembly and analyzing the function in detail.

The 3-D digitizer has an articulated arm that can be moved and rotated in order to pick any point on an existing object or model. The data is transmitted as 3-D points to the CADD software through a cable attached to a serial port on the computer. This process is useful for collecting CADD data of an existing object in order to create a computer model. The computer model can then be revised to construct a new part.



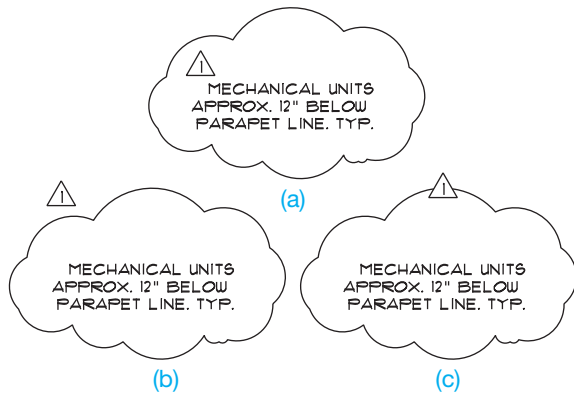
Courtesy FARO Technologies, Inc.

**FIGURE 21.64** The dimensions of an existing pipe can be input to the CADD software using a 3-D digitizer.

### Revision Clouds

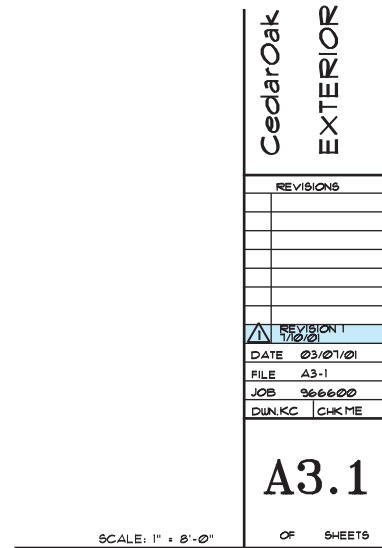
A **revision cloud** is placed around the area that is changed. The revision cloud is a cloudlike circle around the change as shown in Figure 21.65. CADD programs commonly used for pipe drafting have commands that allow you to draw revision clouds

easily. There is also a triangle with a revision number inside that is placed next to the revision cloud or along the revision cloud line as shown in Figure 21.65. The triangle is commonly called a **delta**. The number inside the delta correlates to a **revision note** placed somewhere on the drawing or in the title block as shown in Figure 21.66.



© Cengage Learning 2012

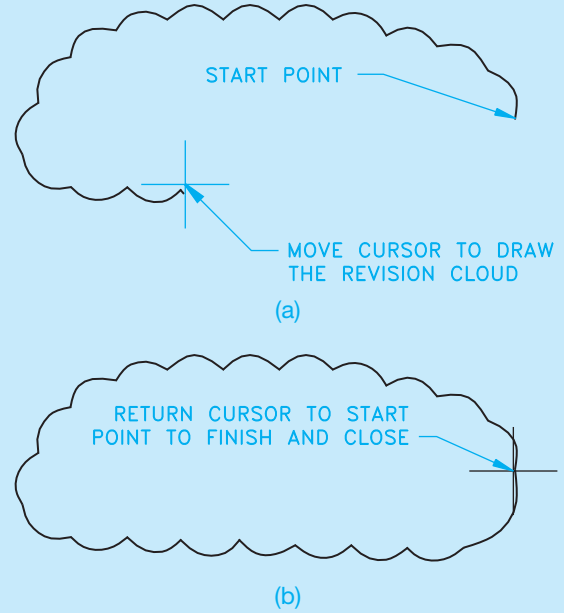
**FIGURE 21.65** Placement of the delta reference with the revision cloud. (a) Delta inside of the revision clouds. (b) Delta outside of the revision cloud. (c) Delta inserted in the revision cloud line.



Courtesy Ankrom Moisan Architects

**FIGURE 21.66** Revision reference in the title block. The specific information about the revision is found in the job file.

It is easy to draw revision clouds with CADD. AutoCAD, for example, has a REVLOUD command that allows you to specify the revision cloud arc length and draw a revision cloud around any desired area. The command works by picking a start point and then moving the cursor in the desired direction to create the revision cloud, as shown in Figure 21.67a. Create the revision cloud in a pattern around the desired area while moving the cursor back toward the start point. When the cursor is returned to a point close to the start point, the cloud is automatically closed as in Figure 21.67b.



**FIGURE 21.67** The AutoCAD REVLOUD command automatically draws arc segments along the path where you move the cursor. (a) Starting and continuing the revision cloud. (b) The complete revision cloud.

© Cengage Learning 2012

Each company has a desired location for revision notes, although common places are in the corners of the drawing, in a revision block or table, or in the title block. This practice is not as clearly defined as in ASME standard drawings. The note is used on the drawing to explain the change. If a reference is given in the title block, then detailed information about the revision is normally provided in the revision document that is filed with the project information. The revision document is typically filled out and filed for reference. Changes can cause increased costs in the project.

## PIPE DRAFTING LAYOUT TECHNIQUES

Use the following layout steps to create piping drawings:

**STEP 1** Locate all building outlines, concrete foundations, structural steel columns, and equipment. Draw the centerlines of the pipe that connects the equipment. (See Figure 21.68a.)

### CONSIDERATIONS:

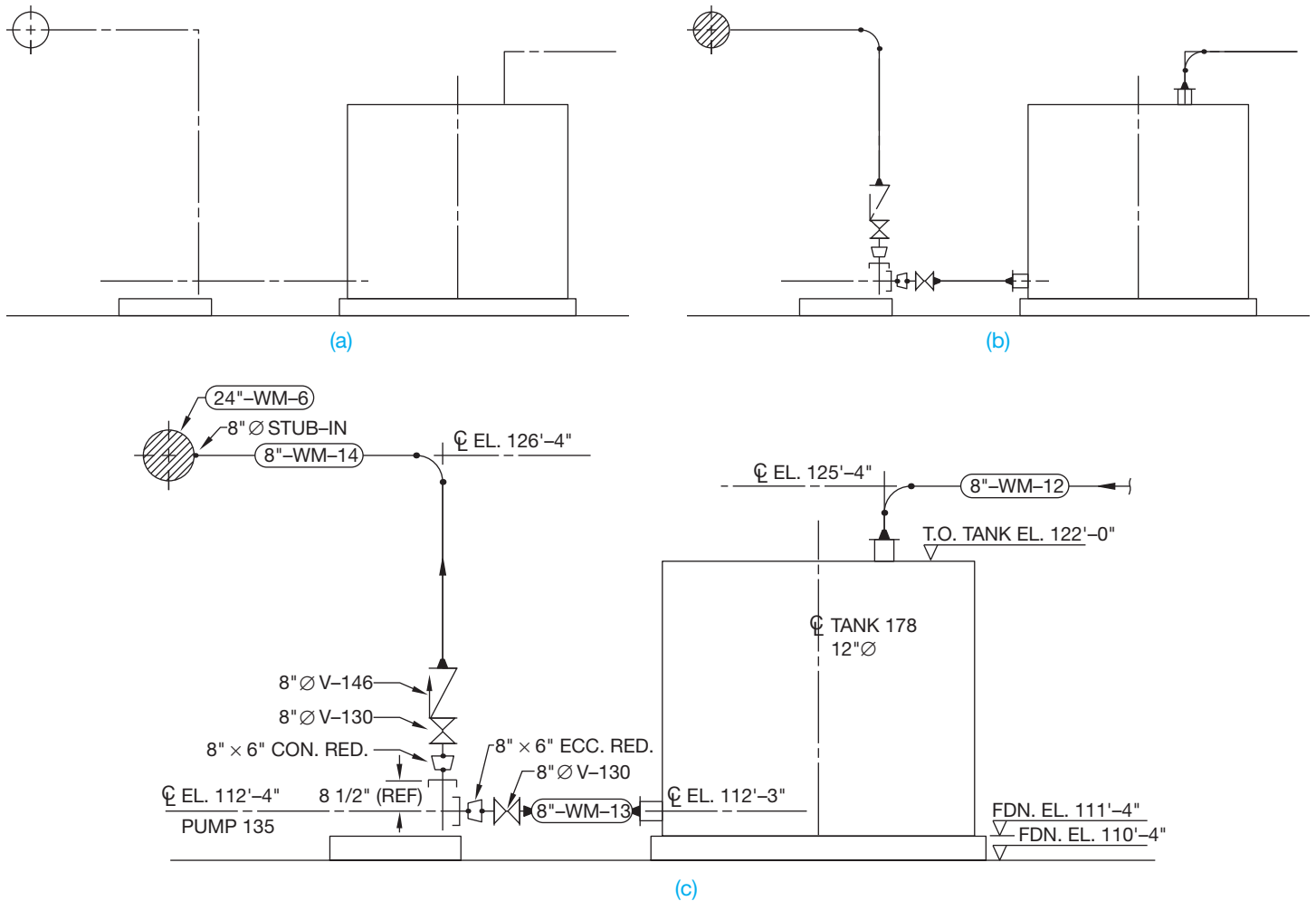
Pipe should be run in such a manner that a minimum number of turns are required. Also, 90° elbows are generally the main turns used.

Most organizations require a minimum amount of pipe to be run between fittings and valves. The minimum length of pipe is generally twice or three times the outside diameter of the pipe. Therefore, for a 4" OD pipe, a company usually requires at least an 8" pipe length.

There must be enough clearance around the pipe for maintenance as well as any insulation required for the safety of personnel.

**STEP 2** Insert fittings and valves in the pipe centerlines and draw pipe, as shown in Figure 21.68b.

**STEP 3** Place dimensions and elevations on the drawing, remembering to keep dimensions and elevations close to where they apply. Locate pipe specification symbols and text in the pipe runs. Add all notes and textual information required (see Figure 21.68c).



**FIGURE 21.68** (a) Equipment outlines and pipe centerlines area located. (b) Pipe, fittings, and valves are added. (c) Dimensions, elevation, and text are added to complete the drawing. © Cengage Learning 2012

## DOWNLOAD BUILDING PRODUCT MODELS, DRAWINGS, AND SPECIFICATIONS

The Autodesk® Seek ([seek.autodesk.com](http://seek.autodesk.com)) free Web service allows architects, engineers, and other design professionals to discover, preview, and download branded and generic building information modeling (BIM) files, models, drawings, and product specifications directly into active design sessions in Autodesk Revit® or AutoCAD® software. For building product manufacturers, Autodesk Seek offers a unique way to connect with the professional designers ultimately responsible for specifying and recommending their products for purchase. Autodesk Seek provides the following features:

- **Manufacturer-supplied product information:** Access BIMs, drawings, and product specifications for more than 35,000 commercial and residential building products from nearly 1000 manufacturers.
- **Powerful parametric search technology:** Search by key attributes, including dimensions, materials, performance, sustainability, or manufacturer name using industry-standard classifications.
- **Preview and explore models before downloading:** View, rotate, zoom, and slice product models and then download the accurate files directly into your design session. For Revit models, preview the family parameters and associated type catalogs before download.
- **Multiple formats:** Select the formats that work for you, such as Revit, DWG™, DGN, and SKP files; Microsoft® Word documents; three-part specifications; and PDFs.
- **Share designs:** You can share designs with peers by uploading them directly from your AutoCAD files to the

(Continued)

Autodesk Seek User Uploads. Easily access the Share with Autodesk Seek button from the Output panel of the ribbon tab. You can choose to share the current drawing or select a block definition within the drawing. Thumbnails, title, and metadata are automatically extracted and indexed. Shared designs can be searched and downloaded by anyone.

When using Autodesk Seek, your default browser launches and displays search results. Figure 21.69 shows

the browser open with a sample of piping search results. A complete set of piping applications are provided in the actual search. Move your cursor over the thumbnail image of the item to view an enlarged image and description of the product. To the right of each piping item are viewing options such as DWG, RFA, DXF, PDF, and Word files.

Similar products are available from other CADD software developers and from product manufacturers.

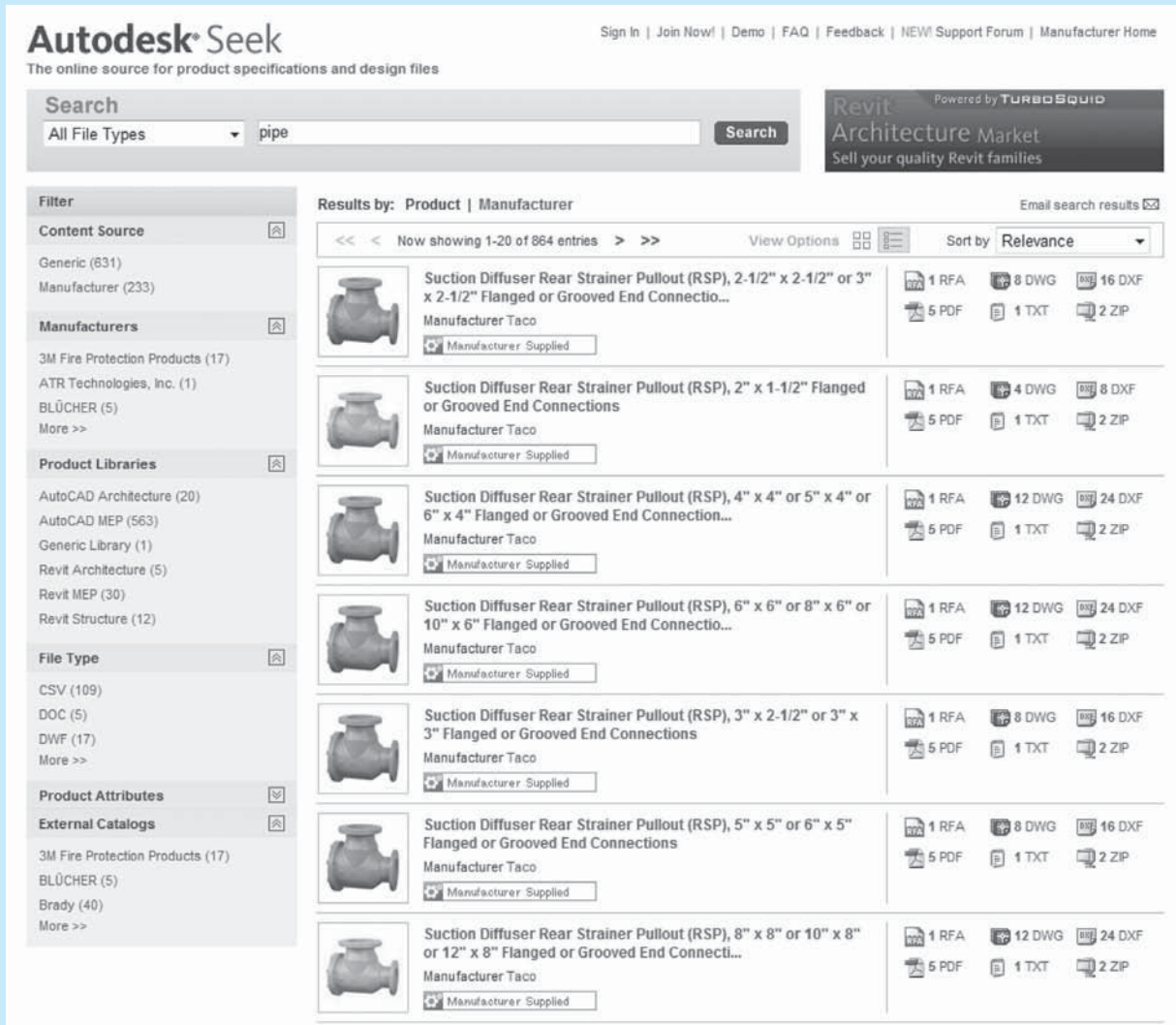


FIGURE 21.69 The browser open with a sample of piping search results displayed using Autodesk Seek.

Courtesy Autodesk, Inc.

# PROFESSIONAL PERSPECTIVE

The field of process piping design and drafting can provide an excellent opportunity for a person to enter engineering. Many consulting engineering companies pay for the education of employees who want to upgrade their skills. This additional education can help as a path toward becoming a designer, technician, or engineer, because you can get valuable job training while working toward an advanced degree.

Piping drafters are often required to work with welders, civil and steel consultants, equipment designers, geological engineers, geophysical engineers, and electrical engineers. Portions of drawings commonly come from different departments, or from different companies or contractors to establish the complete project. Drafters must be able to communicate with all of these people.

A good piping drafter, designer, or engineer is one who is aware of the actual job-site requirements and problems. These field situations are often considerably different from the layout that is designed in the office. Therefore, if you are planning to work in the industrial piping profession, do your best to work on projects in which you can gain field experience. Fieldwork is especially important when adding new equipment and pipe in an existing facility. There are many stories of inexperienced piping designers who have created a design in the office and then gone to the field to find a new 4" pipe routed directly through an existing 12" pipe. Errors like this can happen to anyone, but they happen less often with valuable practical experience.

## USING THE PYTHAGOREAN THEOREM

Industrial pipe design often requires the use of fittings such as 45° elbows to route pipe past obstructions. Exact dimensions of all lengths of pipe and fittings must be calculated before the pipe can be drawn and assembled. When 45° elbows are used, the piping designer must use the Pythagorean theorem to solve for one side of the triangle.

The designer has laid out a run of pipe shown in Figure 21.70. A 45° triangle is applied to the pipe to find the true length, or **travel**, of the angled run of pipe. The length of one side of the triangle is determined by finding the difference between the two elevations given: 2'-9". The two adjacent sides each have a length of 2'-9". Solve for the angled side of the triangle, or **hypotenuse** (see Figure 21.71).

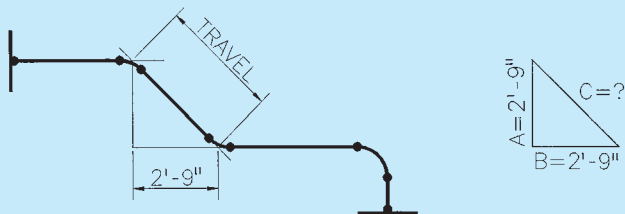


FIGURE 21.70 Find the true length, or travel, of the angled run of pipe. © Cengage Learning 2012

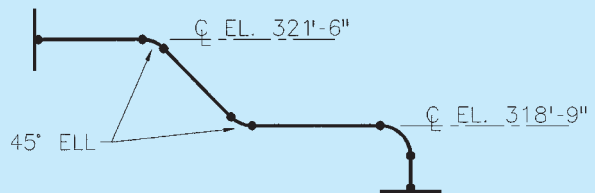


FIGURE 21.71 Solve for the travel (angled) side of the triangle. © Cengage Learning 2012

The **Pythagorean theorem** states that the sum of the squares of the two sides is equal to the square of the hypotenuse or:

$$a^2 + b^2 = c^2$$

Therefore, the square root of the hypotenuse equals the travel of the angled run of pipe.

This problem is solved as follows:

$$\begin{aligned} a^2 + b^2 &= c^2 \\ (2'-9'')^2 + (2'-9'')^2 &= c^2 \quad (\text{Note: } 2'-9'' = 33'') \\ (33)^2 + (33)^2 &= c^2 \\ 1089 + 1089 &= c^2 \\ 2178 &= c^2 \\ \sqrt{2178} &= c \\ c &= 46.669'' \\ c &= 3'-10 \frac{11}{16}'' \end{aligned}$$

## WEB SITE RESEARCH

Use the following Web sites as a resource to help find more information related to engineering drawing and design and the content of this chapter.

Address	Company, Product, or Service
seek.autodesk.com	Autodesk Seek Web service
www.americanbackflow.com	American Backflow Specialties
www.ansi.org	American National Standards Institute (ANSI)
www.asme.org	American Society of Mechanical Engineers (ASME)
www.astm.org	American Society for Testing Materials (ASTM)
www.awwa.org	American Water Works Association (AWWA)
www.craneco.com	Crane Company industrial valves and pumps
www.ias.org	International Society of Automation
www.iso.org	International Organization for Standardization (ISO)
www.kunklevalve.com	Kunkle Valves industrial valves Design Automation
www.powellvalves.com	Powell Valves industrial valves
www.procad.com	PROCAD Software
www.spenceengineering.com	Spence Engineering Company piping accessories

# Chapter 21

## Chapter 21 Industrial Process Piping Test



To access the Chapter 21 test, go to the Student CD, select **Chapter Tests and Problems**, and then **Chapter 21**. Answer the questions

with short, complete statements, sketches, or drawings as needed. Confirm the preferred submittal process with your instructor.

## Chapter 21 Industrial Process Piping Problems

### INSTRUCTIONS

1. Read problems carefully before you begin working. Select or your instructor will assign one or more of the following problems. Complete each problem on an appropriately sized drawing sheet with border and title block as described in this chapter or use the size indicated in the specific instructions, unless otherwise specified by your instructor.
2. Refer to Appendixes W and X for fitting and valve dimensions. Consult with your instructor to determine if specific vendor catalogs should be used to obtain dimensions.
3. Construct your drawings using a CADD system, if indicated in course guidelines.

**Part 1: Problems 21.1 Through 21.15**

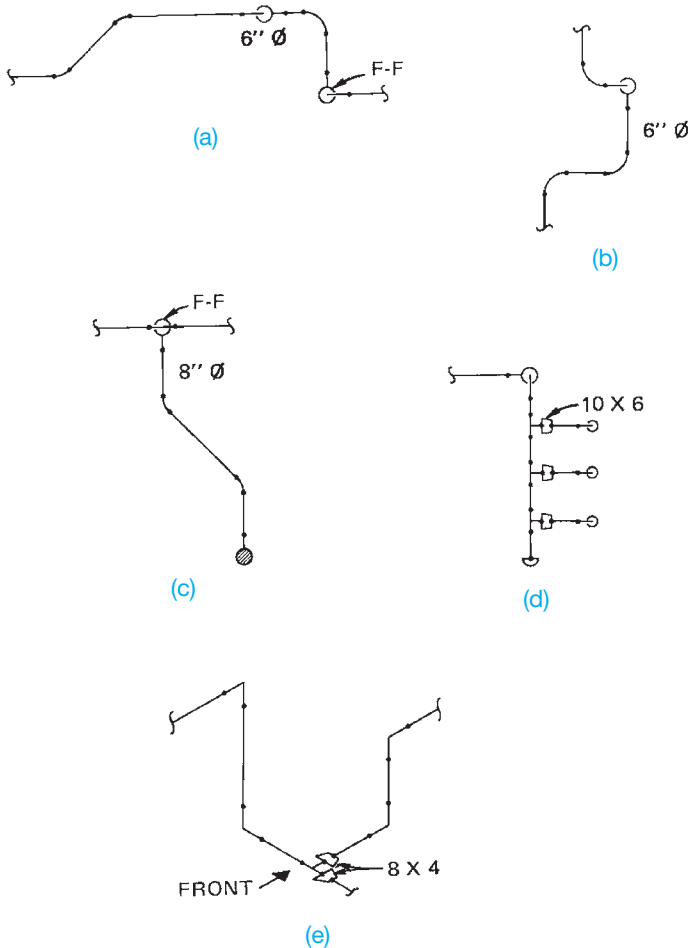
**PROBLEM 21.1** Draw the following fittings in double-line representation. Use 8" diameter NPS and draw at a scale of 1/2" = 1'-0".

- 90° elbow.
- 45° elbow.
- Straight tee.
- Concentric reducer.
- Eccentric reducer.

Draw a front view and each of the four orthographic views (top, bottom, left, and right sides).

**PROBLEM 21.2** Draw the fittings listed in Problem 21.1 in single-line representation. Use the same NPS and the same scale.

**PROBLEM 21.3** Draw each of the five pipe assemblies in double-line form. The view given is the front view.



Draw each of the other four orthographic views (top, bottom, left, and right sides). Use the following information when doing this problem:

- Draw at a scale of 3/8" = 1'-0".
- Use pipe diameters indicated.
- Draw the fittings to scale, but straight lengths of pipe can be drawn proportional to the sketch.
- Pipe that appears to be extending away from the viewer should be drawn fitting-to-fitting if indicated with FF on the sketch. This means that there is no straight pipe in the run that is going away from the viewer. Runs that do contain pipe are not shown with F-F.

**PROBLEM 21.4** Draw the assemblies shown in Problem 21.3 in single-line form. Follow the instructions given in Problem 21.3.

**PROBLEM 21.5** Redraw the ground floor partial plan shown in Figure 21.47a, page 892, on C-size media. Use the following information:

- Draw at a scale of 1/2" = 1'-0".
- Pipe more than 3" in diameter should be drawn in double-line form.
- Use line balloons to indicate pipe specifications.
- Lettering should be 1/8" high.

Use Figure 21.47b–e, pages 893–896, as references for this drawing.

**PROBLEM 21.6** Redraw section E-E, shown in Figure 21.47e, in double-line form at a scale of 1/2" = 1'-0". Use standard dimensions for fittings and valves given in the appendices.

**PROBLEM 21.7** Draw a piping detail of the suction piping of pump P-405 in section B-B, shown in Figure 21.47b.

**PROBLEM 21.8** Redraw section B-B, shown in Figure 21.47b, in single-line form at a scale of 1/2" = 1'-0".

**PROBLEM 21.9** Draw the section C-C shown in Figure 21.47c and section D-D shown in Figure 21.47d in single-line form. Use a scale of 3/8" = 1'-0" on C-size media.

**PROBLEM 21.10** Redraw section E-E, shown in Figure 21.47e, at a scale of 1/2" = 1'-0". Pipe that is greater than 3" in diameter, draw as a single-line. Pipe less than 3" diameter, draw as double-line.



**PROBLEM 21.11** Draw isometric views of the five pipe assemblies shown in Problem 21.3. Draw in single-line form.

**PROBLEM 21.12** Draw a piping isometric of lines 1"–HA–101 in section E-E, shown in Figure 21.47e. Use B-size media.

**PROBLEM 21.13** Draw a plan and elevation of 8"–SH–009, shown in Figure 21.58a, in single-line form.

**PROBLEM 21.14** Draw a plan and elevation of 8"–SH–009, shown in Figure 21.58a, in double-line form.

**PROBLEM 21.15** Draw the spools required for the isometric 4"–SH–004 shown below. Draw one per sheet of B-size media. Include a bill of materials for each spool. The field weld connection point between the two largest spools is indicated by an X just above El. 36'-6". *Courtesy Harder Mechanical Contractors, Inc.*

BILL OF MATERIAL			
ITEM	QTY	SIZE	DESCRIPTION
1	37'	4"	PIPE SCH80 A106-B SMLS
2	2	4"	LR 90° ELL SCH80 A234
3	2	4"	ST. TEE SCH80 A234
4	1	4"x2"	ECC. RED. SCH80 A234
5	1	4"	PIPE CAP SCH80 A234
6	1	2"	RFWN FLG 600# SCH80 A105
7	1	1"	SOCKET 3000# A105
8	2	3/4"	SOCKET 3000# A105
9	1	4"	SH-HV- 007
10	1	2"	PV-466
11	1	4"	SH-HV- 008
12	2	2"	FLEXITALLIC STYLE C-G
13	16	5/8"	4" LG. A193 GR-B7 STUDS W/A194 SFH GR-2H NUTS
REFERENCE DRAWINGS: 12302- M150, REV.2			
HARDER MECHANICAL CONTRACTORS, INC. 2148 N.E. UNION AVE. PORTLAND, OR 97212			
KIEWIT INDUSTRIAL COMPANY MARION COUNTY SOLID WASTE TO ENERGY FACILITY STEAM PIPING			
DR.	ELH / CAD	CHK.	APPR.
DATE			
JOB NO.	85118	DWG. NO.	4"–SH–004
REV.			1

1	6 DEC 00	1'-2 7/16" WAS 2'-0" PER KIC
---	----------	------------------------------

Part 2: Problems 21.16 Through 21.22



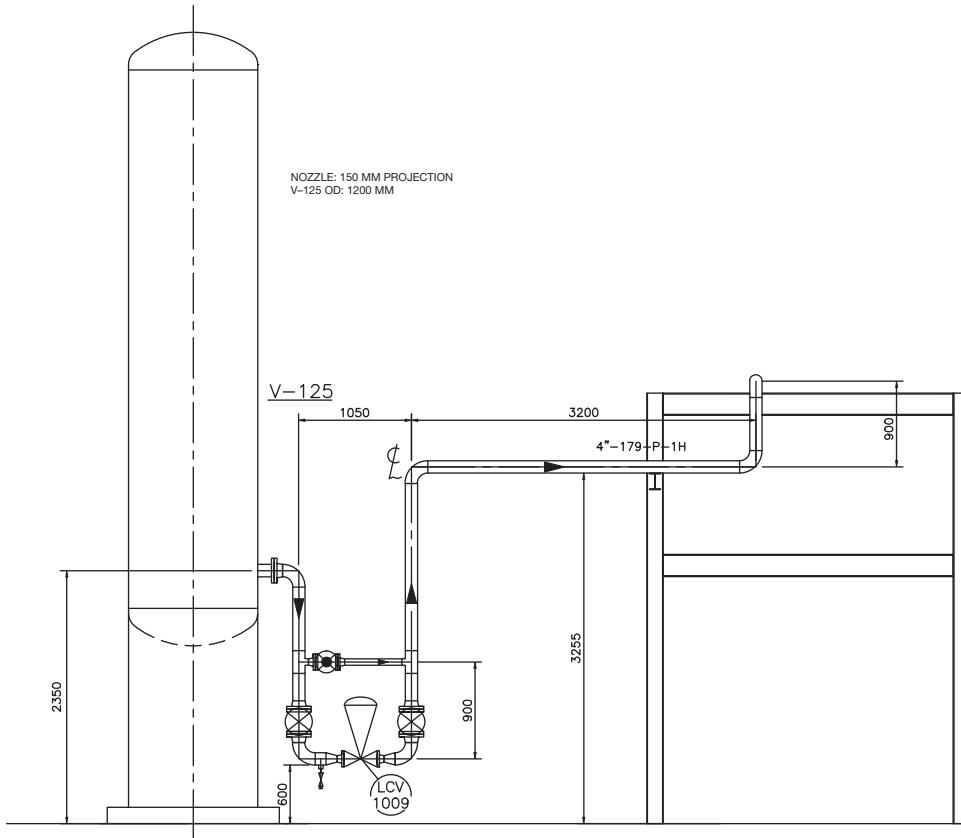
To access the Chapter 21 problems, go to the Student CD, select **Chapter Tests and Problems** and **Chapter 21**, and then open the problem of your choice or as assigned by your instructor. Solve the problems using the instructions provided on the CD, unless otherwise specified by your instructor.

Part 3: Problems 21.23 Through 21.26

**PROBLEM 21.23 Control Station 2-D**

Create a 2-D drawing of the control station and bill of material using the given drawing as a guide. Use a C-size sheet with a border and title block as described in this chapter, unless otherwise specified by your instructor.

*Courtesy PROCAD Software*



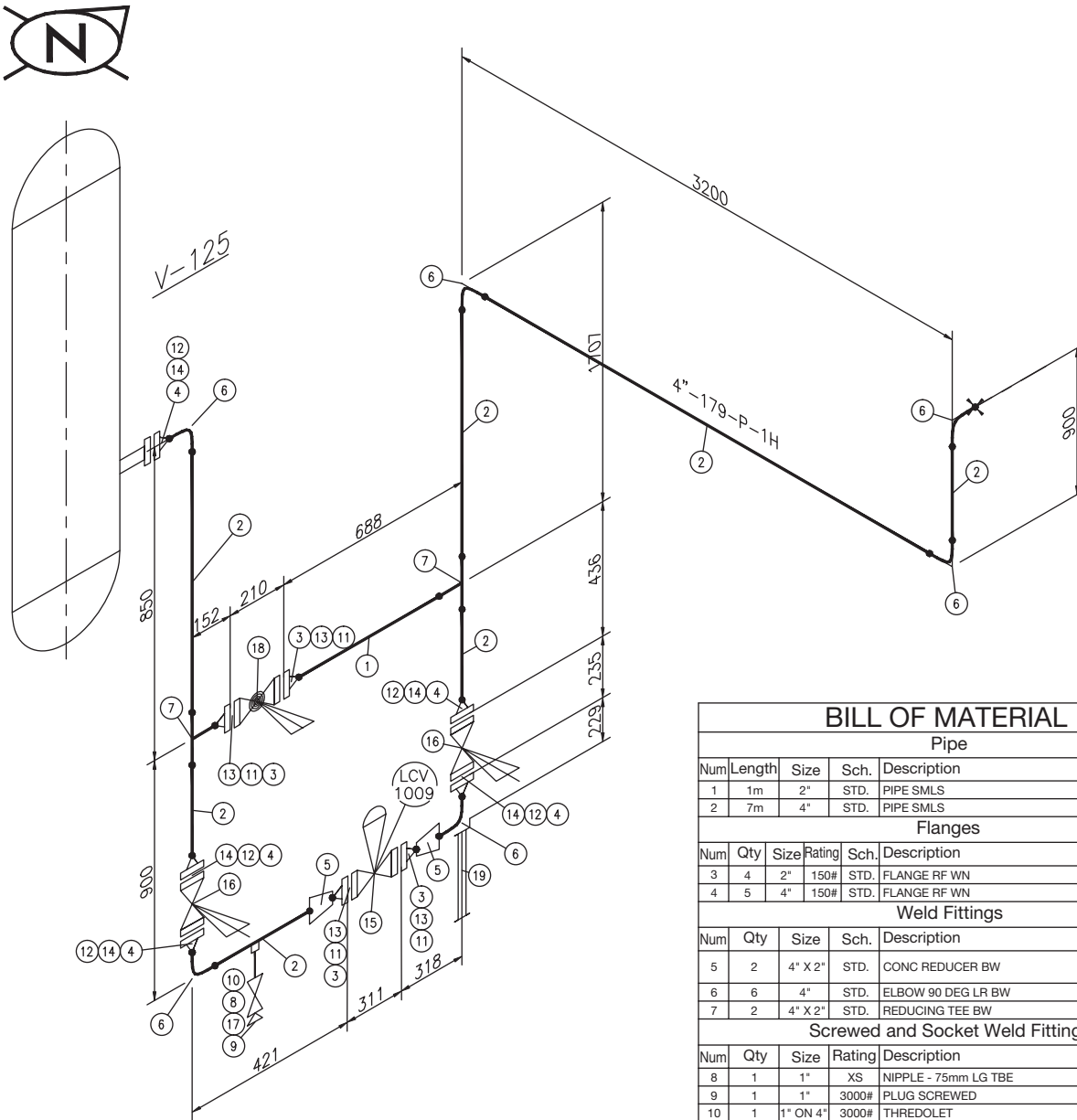
BILL OF MATERIAL							
PIPE							
NUM	LENGTH	SIZE	SCH.	DESCRIPTION	MATERIAL	\$/F	
1	1M	2"	STD.	PIPE SMLS	A106 GR. B	S	
2	10M	4"	STD.	PIPE SMLS	A106 GR. B	S	
FLANGES							
NUM	QTY	SIZE	RATING	SCH.	DESCRIPTION	MATERIAL	\$/F
3	4	2"	150#	STD.	FLANGE RF WN	A105 GR. II	S
4	5	4"	150#	STD.	FLANGE RF WN	A105 GR. II	S
WELD FITTINGS							
NUM	QTY	SIZE	SCH.	DESCRIPTION	MATERIAL	\$/F	
5	2	4" X 2"	STD.	CONC REDUCER BW	ASTM A234 GR. WPB	S	
6	6	4"	STD.	ELBOW 90 DEG LR BW	A234 GR. WPB	S	
7	2	4" X 2"	STD.	REDUCING TEE BW	A234 GR. WPB	S	
SCREWED AND SOCKET WELD FITTINGS							
NUM	QTY	SIZE	RATING	DESCRIPTION	MATERIAL	\$/F	
8	1	1"	XS	NIPPLE - 75MM LG TBE	A106 GR. B	F	
9	1	1"	3000#	PLUG SCREWED	A105 GR. II	F	
10	1	1" ON 4"	3000#	THREDOLET	A105 GR. II	S	
GASKETS							
NUM	QTY	SIZE	RATING	DESCRIPTION	MATERIAL	\$/F	
11	4	2"	150#	GASKET RF 1/8" SPIRAL WOUND	304 SS	F	
12	5	4"	150#	GASKET RF 1/8" SPIRAL WOUND	304 SS	F	
BOLTS							
NUM	QTY	SIZE	DESCRIPTION	MATERIAL	\$/F		
13	4 SETS	5/8" X 3 1/4"	STUD BOLTS CW2 NUTS-4/SET	A193 B7 /A194 2H	F		
14	5 SETS	5/8" X 3 1/2"	STUD BOLTS CW2 NUTS-8/SET	A193 B7 /A194 2H	F		
VALVES							
NUM	QTY	SIZE	RATING	DESCRIPTION	TAG	MATERIAL	\$/F
15	1	2"	150	CONTROL VALVE - D BODY			F
16	2	4"	150#	GATE VALVE RF	GA101	CS	F
17	1	1"	1500#	GATE VALVE SCREWED	GA602	CS	F
18	1	2"	150#	GLOBE VALVE RF	GL101	CS	F

**PROBLEM 21.24 Control Station Isometric**

Create an isometric drawing of the control station and bill of material using the given drawing as a guide. Use a

C-size sheet with a border and title block as described in this chapter, unless otherwise specified by your instructor.

Courtesy PROCAD Software



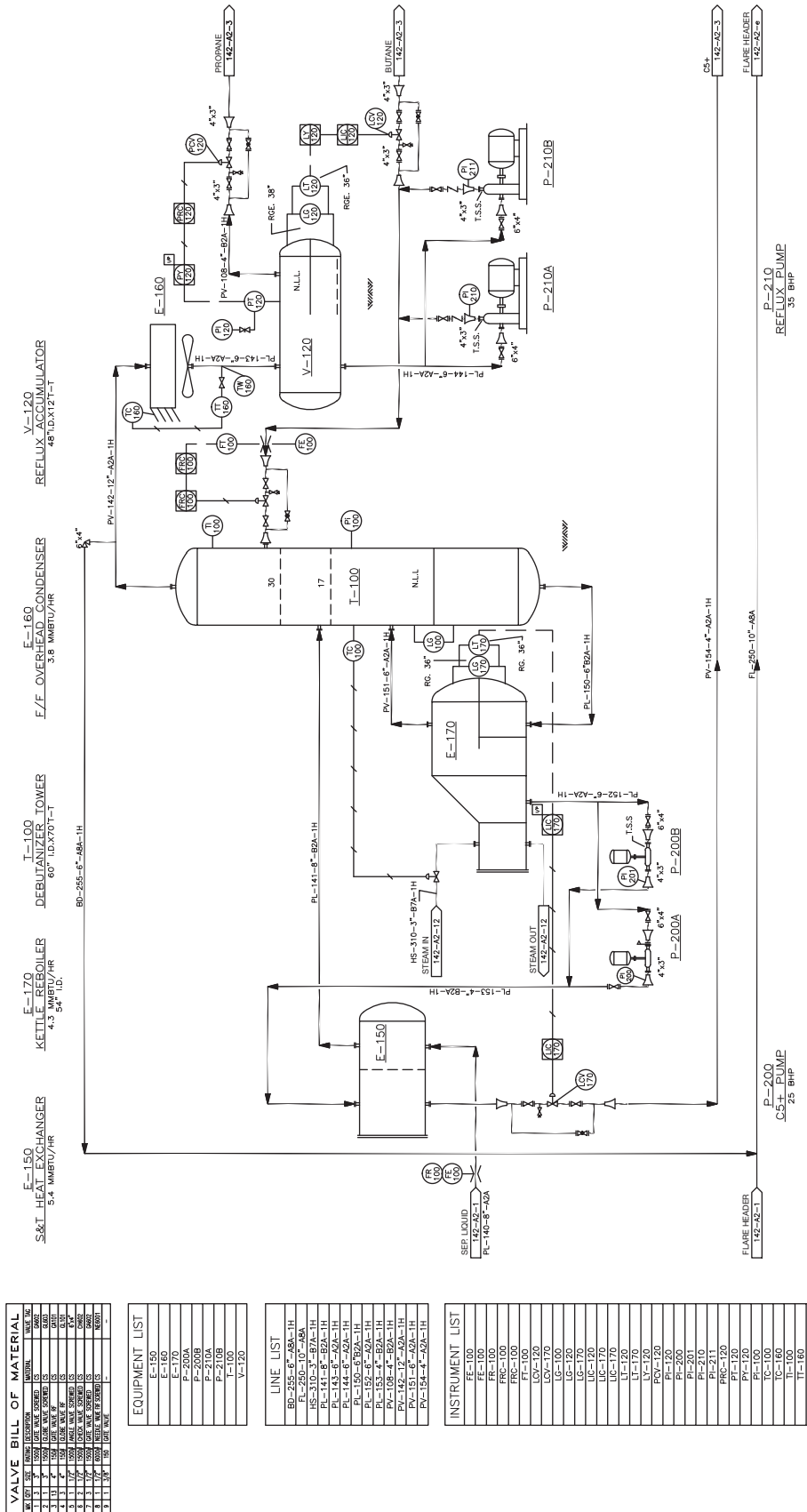
BILL OF MATERIAL							
Pipe							
Num	Length	Size	Sch.	Description	Material	S	F
1	1m	2"	STD.	PIPE SMLS	A106 GR. B	S	
2	7m	4"	STD.	PIPE SMLS	A106 GR. B	S	
Flanges							
Num	Qty	Size	Rating	Sch.	Description	Material	S
3	4	2"	150#	STD.	FLANGE RF WN	A105 GR. II	S
4	5	4"	150#	STD.	FLANGE RF WN	A105 GR. II	S
Weld Fittings							
Num	Qty	Size	Sch.	Description	Material	S	F
5	2	4" X 2"	STD.	CONG REDUCER BW	ASTM A234 GR. WPB	S	
6	6	4"	STD.	ELBOW 90 DEG LR BW	A234 GR. WPB	S	
7	2	4" X 2"	STD.	REDUCING TEE BW	A234 GR. WPB	S	
Screwed and Socket Weld Fittings							
Num	Qty	Size	Rating	Description	Material	S	F
8	1	1"	XS	NIPPLE - 75mm LG TBE	A106 GR. B	F	
9	1	1"	3000#	PLUG SCREWED	A105 GR. II	F	
10	1	1" ON 4"	3000#	THREDOLET	A105 GR. II	S	
Gaskets							
Num	Qty	Size	Rating	Description	Material	S	F
11	4	2"	150#	GASKET RF 1/8" SPIRAL WOUND	304 SS	F	
12	5	4"	150#	GASKET RF 1/8" SPIRAL WOUND	304 SS	F	
Bolts							
Num	Qty	Size	Description	Material	S	F	
13	4 SETS	5/8" X 3 1/4"	STUD BOLTS CW/2 NUTS-4/SET	A193 B7 /A194 2H	F		
14	5 SETS	5/8" X 3 1/2"	STUD BOLTS CW/2 NUTS-8/SET	A193 B7 /A194 2H	F		
Valves							
Num	Qty	Size	Rating	Description	Tag	Material	S
15	1	2"	150	CONTROL VALVE - D BODY			F
16	2	4"	150#	GATE VALVE RF	GA101	CS	F
17	1	1"	1500#	GATE VALVE SCREWED	GA602	CS	F
18	1	2"	150#	GLOBE VALVE RF	GL101	CS	F
Supports and Misc							
Num	Qty	Size	Description	Material	S	F	
19	1	4"	BASE SUPPORT	A106 GR. A	F		



**PROBLEM 21.26 Refinery P&ID**

Create a P&ID drawing of the refinery using the given drawing as a guide. Include the valve bill of material, equipment list, line list, and instrument list. Use a D-size sheet with a border and title block as described in this chapter, unless otherwise specified by your instructor.

*Courtesy PROCAD Software*



VALVE BILL OF MATERIAL		
NO.	SIZE	MARKING
1	1/2"	150-100-1
2	1/2"	150-100-2
3	1/2"	150-100-3
4	1/2"	150-100-4
5	1/2"	150-100-5
6	1/2"	150-100-6
7	1/2"	150-100-7
8	1/2"	150-100-8
9	1/2"	150-100-9
10	1/2"	150-100-10
11	1/2"	150-100-11
12	1/2"	150-100-12
13	1/2"	150-100-13
14	1/2"	150-100-14
15	1/2"	150-100-15
16	1/2"	150-100-16
17	1/2"	150-100-17
18	1/2"	150-100-18
19	1/2"	150-100-19
20	1/2"	150-100-20
21	1/2"	150-100-21
22	1/2"	150-100-22
23	1/2"	150-100-23
24	1/2"	150-100-24
25	1/2"	150-100-25
26	1/2"	150-100-26
27	1/2"	150-100-27
28	1/2"	150-100-28
29	1/2"	150-100-29
30	1/2"	150-100-30
31	1/2"	150-100-31
32	1/2"	150-100-32
33	1/2"	150-100-33
34	1/2"	150-100-34
35	1/2"	150-100-35
36	1/2"	150-100-36
37	1/2"	150-100-37
38	1/2"	150-100-38
39	1/2"	150-100-39
40	1/2"	150-100-40
41	1/2"	150-100-41
42	1/2"	150-100-42
43	1/2"	150-100-43
44	1/2"	150-100-44
45	1/2"	150-100-45
46	1/2"	150-100-46
47	1/2"	150-100-47
48	1/2"	150-100-48
49	1/2"	150-100-49
50	1/2"	150-100-50

EQUIPMENT LIST	
E-150	S&T HEAT EXCHANGER
E-170	KETTLE REBOILER
I-100	DEBUZZANIZER TOWER
E-160	E/F OVERHEAD CONDENSER
V-120	REFLUX ACCUMULATOR

LINE LIST	
BD-255-6"-A9A-1H	BD-255-6"-A9A-1H
PL-250-10"-A9A	PL-250-10"-A9A
HS-310-3"-B7A-1H	HS-310-3"-B7A-1H
PL-144-8"-A2A-1H	PL-144-8"-A2A-1H
PL-144-8"-A2A-1H	PL-144-8"-A2A-1H
PL-150-6"-B2A-1H	PL-150-6"-B2A-1H
PL-152-6"-A2A-1H	PL-152-6"-A2A-1H
PL-151-6"-A2A-1H	PL-151-6"-A2A-1H
PV-142-12"-A2A-1H	PV-142-12"-A2A-1H
PV-151-6"-A2A-1H	PV-151-6"-A2A-1H
PV-154-4"-A2A-1H	PV-154-4"-A2A-1H

INSTRUMENT LIST	
FE-100	FE-100
FE-100	FE-100
FRG-100	FRG-100
FRG-100	FRG-100
FT-100	FT-100
LCV-120	LCV-120
LG-100	LG-100
LG-120	LG-120
LC-170	LC-170
LC-170	LC-170
LC-170	LC-170
LT-120	LT-120
LT-120	LT-120
LY-120	LY-120
PCV-120	PCV-120
PI-120	PI-120
PI-200	PI-200
PI-210	PI-210
PI-210	PI-210
PRG-120	PRG-120
PI-120	PI-120
PI-100	PI-100
TC-100	TC-100
TC-100	TC-100
TI-160	TI-160
TW-160	TW-160

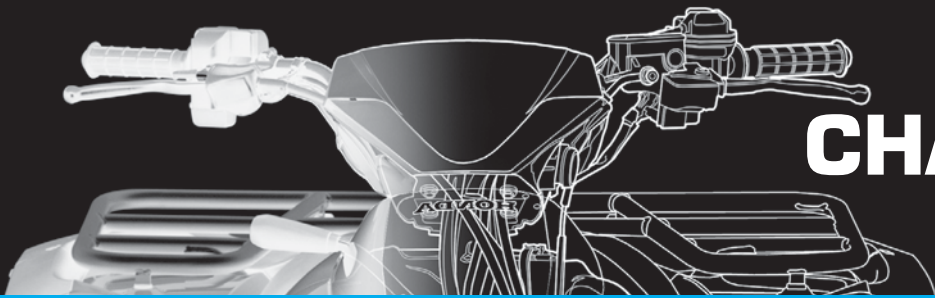
## Math Problems

### Part 4: Problems 21.27 Through 21.29



To access the Chapter 21 problems, go to the Student CD, select **Chapter Tests and**

**Problems** and **Chapter 21**, and then open the math problem of your choice or as assigned by your instructor. Solve the problems using the instructions provided on the CD, unless otherwise specified by your instructor.



# CHAPTER 22

## Structural Drafting

### LEARNING OBJECTIVES

After completing this chapter, you will:

- Identify, describe, and draw various components of the following commercial construction methods: concrete, concrete block, wood, heavy timber, laminated beam, and steel.
- Prepare a complete set of structural drawings.
- Draw and document drawing revisions.
- Draw commercial structural drawings from engineering sketches.

## THE ENGINEERING DESIGN APPLICATION

In many situations, the drafter prepares formal drawings from engineering calculations and sketches. The drafter is also commonly called a **detailer** in the structural drafting discipline. Structural steel fabricators who construct the steel structure or building heavily depend on detailed drawings prepared by the structural drafter or detailer. The steel detailer produces detail drawings using the construction drawings supplied by a structural engineer. The actual detail drawings often depend on the availability of material and shop fittings, such as structural connections. Registered structural engineers, architects, or designers with experience and training often prepare structural calculations and design. The entry-level engineering drafter may not fully understand the calculations, but the drafter can interpret the results of the calculations because the engineer or designer normally highlights the solution to be placed on the drawing by clearly underlining or placing a box around the solution as shown in Figure 22.1.

When engineering calculations result in a design sketch, the drafter's job is to convert the sketch to a formal drawing as shown in Figure 22.2b. The quality and completeness of the engineering sketch often depends on the experience of the drafter. To prepare required drawings with accuracy, the drafter must have a comprehensive knowledge of the standard engineering specifications and an understanding of shop fabrication, the field erection process, and structural drafting applications. If this is the drafter's first job, then the engineer may have to take a little more time providing detailed information until the drafter gains experience.

Once the drafter has had some experience, the engineering sketches can be less complete. For example, if the

ROOF SHEATHING - WAREHOUSE ENGINEER'S GOAL

$$W_v = 25 \text{ PSF}$$

$$W_L = \frac{88650}{(2)(102)} = 303 \text{ \#1}$$

$$= \frac{89124}{(2)(391)} = 92 \text{ \#1}$$

ASSUME JOIST @ 32" O.C.

CHECK 5/8" C-D 42/20 PLYWOOD

$$W = 35 \text{ PSF} > 25 \text{ PSF}$$

$$V = 425 \text{ \#1 UNBLOCKED} > 303 \text{ \#1}$$

$$= 285 \text{ \#1 UNBLOCKED}$$

$$= 215 \text{ \# UNBLOCKED} > 92 \text{ \#1}$$

DETERMINE BLOCKING TERMINATION

$$x = \frac{(285)(100.5)}{365} = 126.1'$$

$$d = 100.5 - 126 = 3550 \Rightarrow 37.33' \text{ FROM EA. END WALL}$$

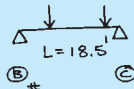
USE: 5/8" C-D, 42/20, INTERIOR APA PLYWOOD W/ EXTERIOR GLUE. PROVIDE BLOCKING @ 37.33' ADJACENT TO END WALLS. NAIL W/ 10d COMMON NAILS @ 4" O.C. @ ALL PANEL EDGES @ BLOCKED AREAS, @ 0' O.C. @ ALL SUPPORTED PANEL EDGES @ UNBLOCKED AREAS @ 12" O.C. @ ALL INTERMEDIATE SUPPORTS.

THIS IS WHAT GOES ON THE PLAN

**FIGURE 22.1** Engineering calculations typically contain a problem to be solved, mathematical solutions, and specifications to be placed on the drawing. The drawing note or information is placed in a box or otherwise highlighted.  
© Cengage Learning 2012

engineering sketch in Figure 22.2a had omitted the note 3/16" PLY SHIM EA SIDE GLUE AND NAIL W/ 4-ROWS 8-10d COMMON, an experienced drafter would realize that shims are required when two **beams** of different thicknesses are joined. Beams are horizontal structural members used to support roof or wall loads. In some situations, an experienced drafter can work directly from the engineering calculations without sketches. In all situations, it is very important for the drafter to maintain a current

CARRIER PURLINS  
LINE ①



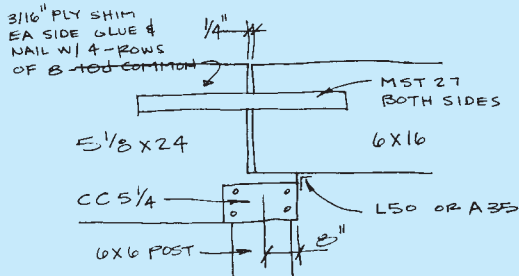
$$\begin{aligned}
 TA &= 8 \times 10 \times 3 + 5 \times 10 = 290 \# \\
 P_1 &= (10 + 16) 8 \times 20 = 1600 + 3200 = 4800 \\
 P_2 &= (10 + 16) 8 \times 10 + (10 + 16) 5 \times 10 = 1300 + 2080 = 3380 \\
 RB &= \frac{(1600 + 3200) 11 + (1300 + 2080) 3}{18.5} = 1162 + 2240 = 3406 \\
 RC &= \frac{(1600 + 3200) 7.5 + (1300 + 2080) 15.5}{18.5} = 1738 + 3040 = 4778 \\
 M &= 3406 \times 7.5 = 25516 \\
 S &= \frac{25516 \times 12}{1.25 \times 1300} = 188.4 \quad 6 \times 16; \quad S = 220
 \end{aligned}$$

6 x 16 DFL #1

LINE ②

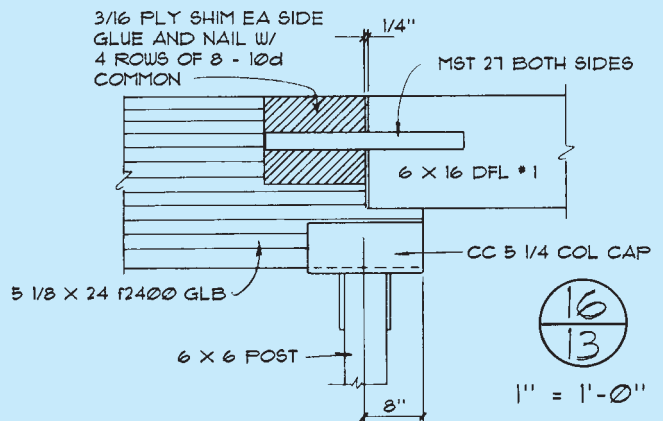
$$\begin{aligned}
 TA &= 8 \times 10 \times 2 + 5 \times 10 \times 2 = 260 \# \\
 P_1 &= 4800 \text{ (SEE ABOVE)} \\
 P_2 &= (10 + 16) 5 \times 20 = 1000 + 1600 = 2600 \\
 RB &= \frac{(1600 + 3200) 11 + (1000 + 1600) 3}{18.5} = 1114 + 2162 = 3275 \\
 RC &= \frac{(1600 + 3200) 7.5 + (1000 + 1600) 15.5}{18.5} = 1486 + 2638 = 4124 \\
 M &= 3275 \times 7.5 = 24568
 \end{aligned}$$

6 x 16 DFL #1



(a)

set of a vendor's catalogs. These catalogs give the detailed information necessary for reproducing and labeling the drawings. The kinds of information found in a vendor's catalog allow the drafter to complete the drawing in Figure 22.2b with the dimensions and specifications for the MST 27 straps, CC 5-1/4 COLUMN CAP, and L50 or A35 framing anchor.



(b)

**FIGURE 22.2** (a) A sample of engineer's calculations to determine the loading criteria at a beam connection over a column. (b) The drafter draws the detail to convey the information of the engineer's calculation and sketch, using proper drafting techniques. © Cengage Learning 2012

## INTRODUCTION

**Documents** is a general term that refers to all drawings and written information related to a project. **Construction documents** are drawings and written specifications prepared and assembled by architects and engineers for communicating the design of the project and administering the construction contract. The two major groups of construction documents are bidding requirements and contract documents. **Bidding requirements** are used to attract bidders and provide the procedures to be used for submitting bids. Bidding requirements are the construction documents issued to bidders for the purpose of providing construction bids. **Contract documents** are the legal requirements that become part of the construction contract. Contract documents are where the construction drawings and specifications are found.

## Construction Drawings

**Construction drawings** are a principal part of the set of construction documents. The individual drawings needed depend on the specific requirements of the construction project. The drawings for a small residential addition might fit on one or two pages, whereas the drawings for a commercial building might be on 100 or more pages. Drawings vary in how much information they show, depending on the use, the project phase, and the desired representation. In addition to plan views, elevations, sections, and details, drawings can have schedules that have a detailed list of components, items, or parts to be furnished in the project.



## Coordinating Drawings and Specifications

A complete set of construction documents contains **drawings** and **specifications**. These combined drawings and specifications are often referred to as *plans*. One person or a unified team of people should coordinate drawings and specifications. The elements used in the drawings and specifications, such as symbols, abbreviations, and terminology, should be standardized to help avoid confusion. After the construction documents are prepared in a professional manner, the construction coordination must be conducted with effective communication.

The drawings should locate and identify materials and should include the assembly of components, dimensions, details, and diagrams. The drawings have notes, but notes should be used only to identify, not to describe, a material or part. Notes that are too detailed can obscure the drawing. Detailed written information should be placed in the specifications. Symbols used in the set of drawings should be represented as an approved standard and should be shown and labeled in a legend for reference purposes. Drawings do not need to be cross-referenced to the specifications. Drawings and specifications are combined to become the complete set of construction documents, which means that you do not have to provide notes that refer to the specifications when identifying an item on the drawings. The specifications are used to define the specific quality and type of material, equipment, and installation. The drawings provide quantity, capacity, location, and general written information in the form of notes, whereas the specifications clearly define items such as minimum requirements, physical properties, chemical composition, and installation procedures.

**Schedules** are used on drawings to help simplify communication by providing certain items in a table format. The schedules can be placed on the drawings or in the specifications. The information found in schedules or on the drawings should not repeat the information found in the specifications. The drawings, schedules, and specifications must be carefully coordinated so the information is consistent. The MasterFormat divisions and sublevels can be used as a checklist to ensure that every required specification is included. MasterFormat is an effective system for indexing large project specifications, and it can be used for light commercial or residential construction. The MasterFormat is described in detail later in this chapter.

## STRUCTURAL ENGINEERING

A **structural engineer** works with architects and building designers to engineer the structural components of a building. Structural engineering is generally associated with commercial steel and concrete buildings and sometimes also for the structural design of residential buildings. The structural engineer also works with civil engineers to design bridges and other structures related to road and highway construction. Mechanical engineers can also be involved in the structural project by

designing machinery supports and foundations. There is a wide variety of projects in which structural drafting is involved. Structural drafting techniques are generally the same as mechanical drafting, although a combination of mechanical and architectural methods are used.

Structural engineers or architects produce **design drawings**. Design drawings contain all the details required to prepare structural drawings. Design drawings provide data on loads, **axial forces**, **moments**, and **shear forces**. Axial forces are forces working along the axis of a structure such as a column. Moments are a measure of resistance to changes in the rotation of an object, also referred to as **moment of inertia**. Shear forces are forces caused when two construction pieces move over each other. Design drawings also contain information of each framing member, precise dimensions, the location of each beam and column, and general notes for reference.

**Structural engineering drawings** and **detail drawings** show the results of structural designing in a condensed form. Drawings, general notes, schedules, and specifications serve as instructions to the contractor. The drawings must be complete and have sufficient detail so no misinterpretation can be made. Structural drawings are usually independent of architectural drawings and other drawings, such as plumbing or heating, ventilating, and air-conditioning (HVAC). When necessary, structural drawings are clearly cross-referenced to architectural drawings.

### STANDARDS

Structural drafting standards are based on the best practices typically found in the structural industry and on engineering codes established by the American Institute of Steel Construction (AISC) ([www.aisc.org](http://www.aisc.org)), the American National Standards Institute (ANSI) ([www.ansi.org](http://www.ansi.org)), and the American Institute of Architects (AIA) ([www.aia.org](http://www.aia.org)). Structural drawing practices refer to a style or quality of a drawing provided by the individual drafter in compliance with traditional practices. Structural drafting standards are characterized by crisp black line work, quality lettering, consistency, and uniformity. The structural drafter considers the production of precise detail drawings as an art and a serious engineering accomplishment.

## LINE WORK ON STRUCTURAL DRAWINGS

The lines used in structural drafting are generally the same as those used in mechanical drafting. There are a few exceptions. For example, the visible object line can be drawn thicker than normal when a shape or feature requires extra emphasis. Object lines can also be thinner than the standard when used on a small-scale drawing, though they should still be thick enough to differentiate from nonessential elements (see Figure 22.3). Dimension lines can be drawn with a space provided for the numeral as in

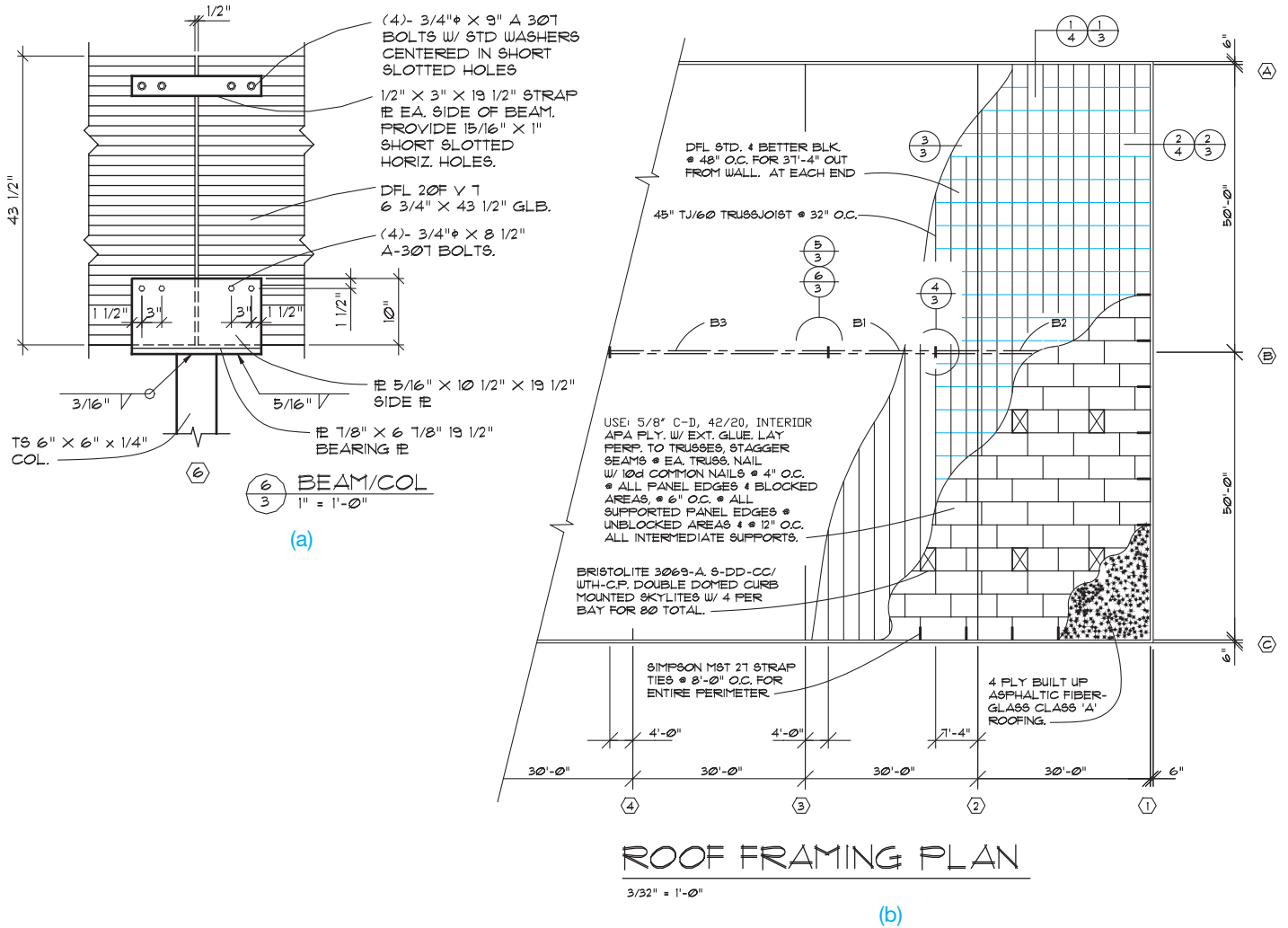


FIGURE 22.3 (a) Thick object lines for emphasis used on a beam and column detail. (b) Thin object lines on small-scale drawing used on a panelized roof framing system. © Cengage Learning 2012

mechanical drafting, but the common structural drafting practice is for the numeral to be placed above the dimension line as in architectural drafting. The dimension line is most commonly capped on the end with arrowheads, but architectural tick marks are also used (see Figure 22.4). Refer to Chapter 10, *Dimensioning and Tolerancing*, for additional dimensioning practices, terminology, and examples. Cutting-plane lines and symbols are provided one of several ways, as shown in Figure 22.5.

A common way to create the cutting-plane symbol is to draw a circle with a vertical or horizontal line through the middle, depending on the symbol orientation. The line can be at an angle if the symbol is oriented at an angle through the building or view. The top half of the circle has a letter identifying the section, and the bottom half has a number, or letter and number combination, identifying the sheet where the sectional view is located. Some companies vary from this procedure by indicating the sheet number from where the detail was taken on the sheet where the detail is shown. For example, look ahead to the

detail in Figure 22.7a; it shows sheet number A4.2, indicating the sheet from where the detail originates.

A solid-filled triangle is generally drawn attached to the circle as shown in Figure 22.5. The sides of the triangle can be tangent to the circle or slightly past the tangency as in the given example. The point of the triangle represents the direction of sight for the cutting plane. The cutting-plane symbol can be duplicated on each side of the building or view, or an arrow representing the continued cutting plane can be placed across the building or view. Although cutting-plane representations are similar throughout this chapter, there are some differences, depending on company preference. Options 1 and 2 shown in Figure 22.5 are the most commonly used and conform to standards and conventions. Option 3 is sometimes used by companies. However, the method used should be consistent throughout each set of structural drawings. Review Chapter 12, *Sections, Revolutions, and Conventional Breaks*, for detailed information about sectioning practices.

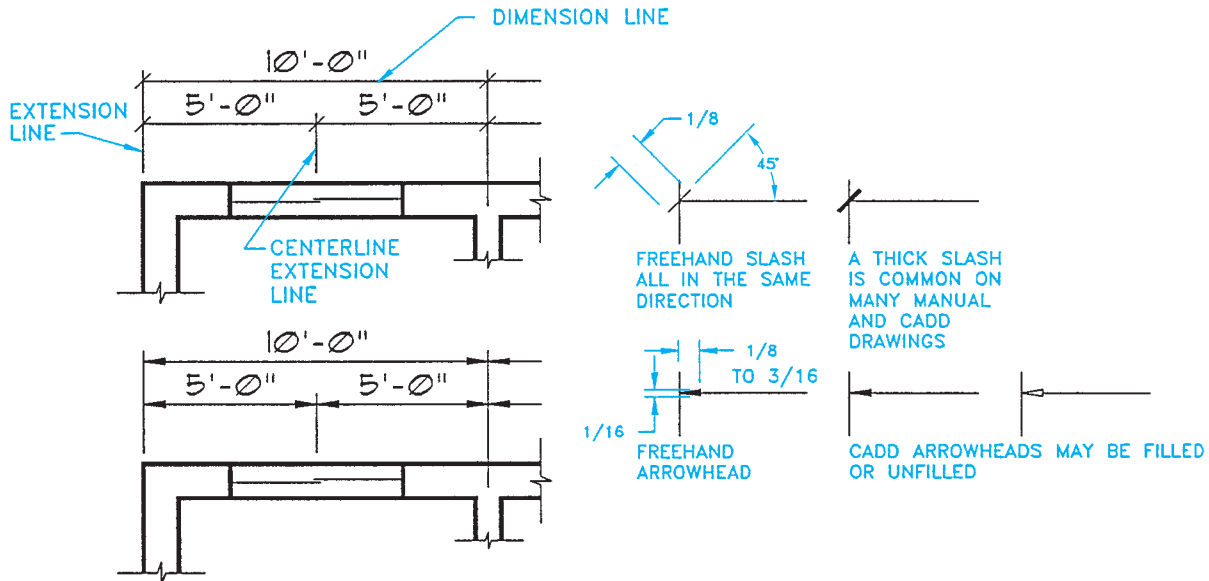


FIGURE 22.4 Dimension line examples.

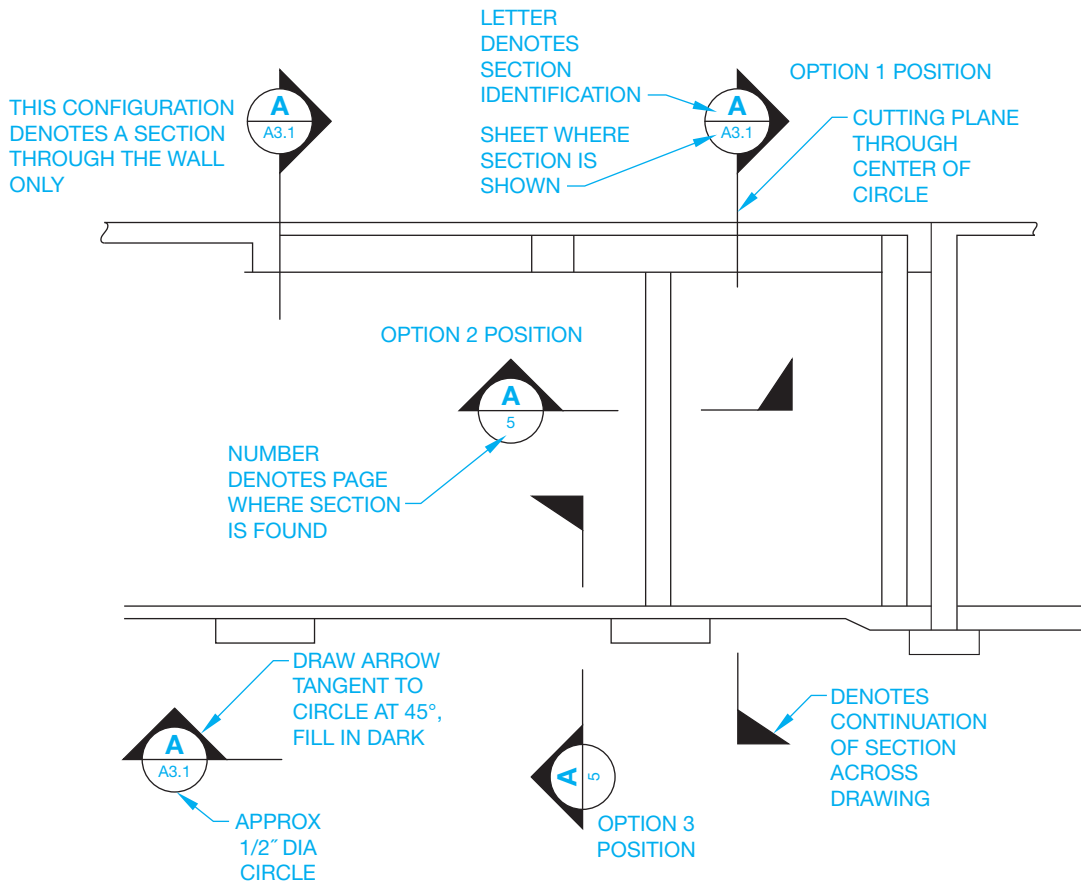


FIGURE 22.5 Cutting-plane line symbols. Options 1 and 2 shown are the most commonly used and conform to standards and conventions. Option 3 is sometimes used by companies.

## LETTERING ON STRUCTURAL DRAWINGS

The quality of lettering in structural drafting is equally as important as it is in other drafting fields. There is a great deal of lettering on structural drawings. A well-developed, legible style of lettering adds professional quality to the drawing. The common standard for lettering is the Gothic style used in mechanical drafting. However, the structural drafter has more freedom of style and so may use an architectural lettering style if it is allowed by company standards. Structural drafters sometimes prefer slanted letters. Lettering height on drawings is typically 1/8 in. (3 mm), although 3/32" to 5/32" (2.5–4 mm) heights are also used for all lettering except titles, which are 3/16" to 1/4" (5–6 mm) in height. If drawings are to be microfilmed, then 5/32" lettering is used. Figure 22.6a shows architectural-style lettering used in structural drafting. Figure 22.6b shows the more common Gothic lettering style used in structural drafting. Chapter 6, *Lines and Lettering*, presents other lettering rules.

## COORDINATION OF WORKING DRAWINGS

Structural drawings are a portion of a complete set of working drawings. A set of drawings for a commercial project can have more than 100 pages. Because of the complex nature of the drawings and the number of disciplines involved, the set of drawings is often divided into several major groups.

Common major groups include architectural, structural, mechanical (HVAC), plumbing, electrical, and fixture drawings. The architect normally prepares the architectural drawings. The architect then coordinates with consulting engineering firms that prepare the drawings for their specific disciplines. The structural engineering firm generally prepares the related structural drawings, which include the steel and concrete parts of the project.

## Drawing Sheets

Drawing sheets used for structural drafting are commonly the large sheet format also used for architectural, mechanical, and piping drawings. The E-size 44 × 34 in. (A0 size 1189 × 841 mm) sheet is common, but other sheet sizes are also used. Most sheets have a border and title block, with the title block along the bottom or right side of the sheet as shown in Figure 22.7. Title block information can include content such as company name and logo, company address and phone number, revision history block, engineering stamp, customer name and project name, and approval signatures.

## Numbering Sheets

A set of structural drawings requires a specific page-numbering system because of the large number of pages. When a set of drawings has a number of pages that are easy to manage, it is common to see pages numbered in consecutive order such as

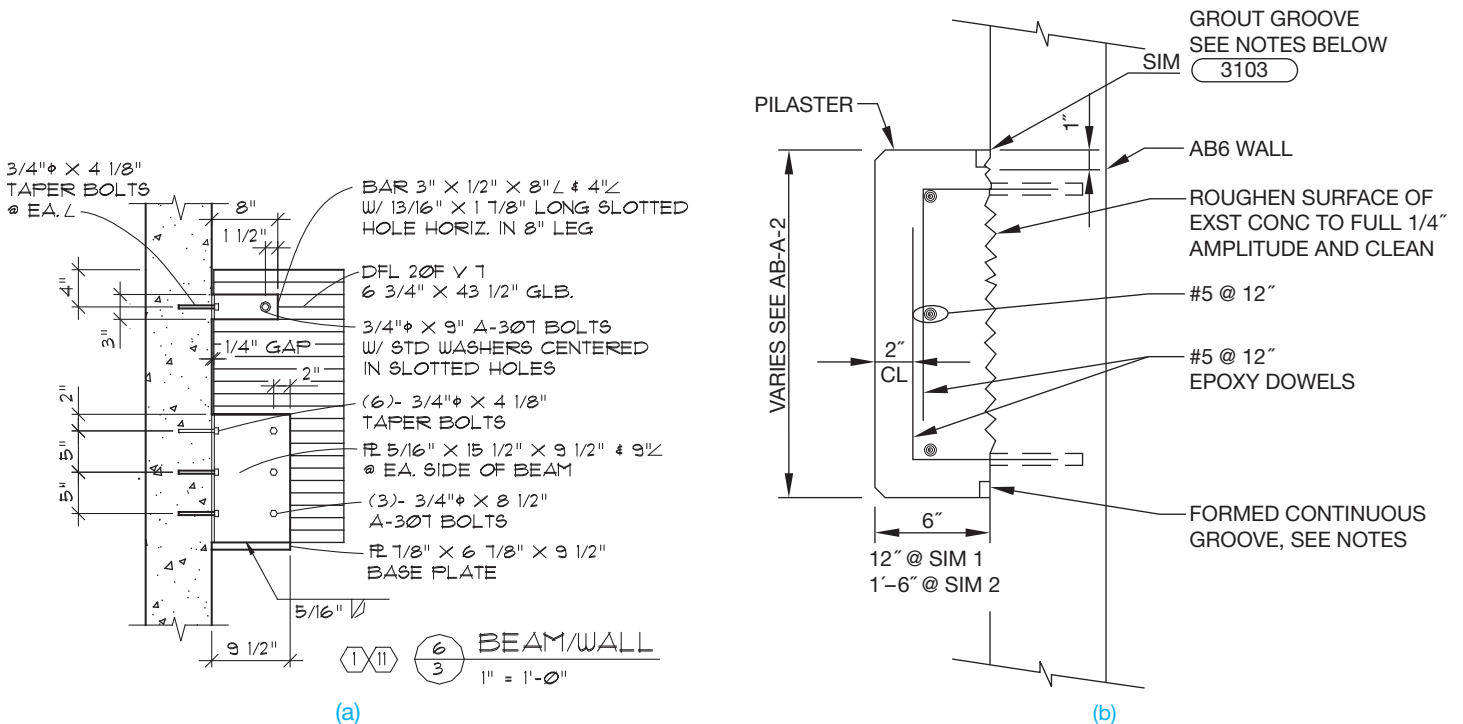


FIGURE 22.6 (a) Architectural lettering style used in structural drafting. (b) The Gothic lettering style is commonly used in structural drafting. © Cengage Learning 2012



1, 2, 3, 4. If a sheet has subpages, then letters might follow the sheet number alphabetically, such as 4A, 4B, 4C, 4D. The actual numbering of pages, and page descriptions, varies between regions of the country, structural engineering companies, and client preference. *The Architect's Handbook of Professional Practice* recommends a decimal page-numbering system. The following general numbering system is an example of how sheets are categorized, but this can change according to each project.

#### Architectural

- T1 Title sheet, site demolition, and survey
- A1 Site plan and details
- A2 Grading plan and details
- A3 First floor plan and details
- A4 Second floor plan, sections, and details
- A5 Enlarged plans, interior elevations, and details
- A6 Exterior elevations and details
- A7 Building and wall sections and details
- A8 Roof plan and details
- A9 Details
- A10 Reflected ceiling plan and details

#### Civil

- U1 Site utilities
- U2 Erosion control plans and details
- U3 Public utility plan
- U4 Utility details

#### Landscape

- L1 Irrigation system plan and legend
- L2 Irrigation system details and notes
- L3 Planting plan, details, and notes

#### Structural

- S1 Foundation plans
- S2 Floor plans
- S3 Roof framing plans
- S4 Typical details, elevations, schedules
- S5 Foundation details
- S6 Framing details
- S7 General notes (either here or on the first sheet)

#### Mechanical

- M1 First-floor plumbing plan, legends
- M2 Second-floor plumbing plan, notes
- M3 Details and schedules
- M4 First-floor HVAC plans and legends
- M5 Second-floor HVAC plan
- M6 Roof-mounted HVAC equipment plan
- M7 HVAC details and schedules

#### Electrical

- E1 Notes, legend, riser
- E2 First-floor lighting plan
- E3 Second-floor lighting plan
- E4 First-floor power plan
- E5 Second-floor power plan
- E6 Roof-mounted equipment power plan
- E7 Details and schedules
- E8 First floor communications plan and legend
- E9 Second-floor communications plan

#### Fixtures

- F1 Fixture plan and schedules
- F2 Details

The general groups and elements within the groups can differ, depending on the company practice and the building being designed. Each category within a general group can have additional pages. These pages are numbered with the sequential decimals of .1, .2, .3. Therefore, the architectural drawings might have pages such as:

- A1.1, A1.2, A1.3
- A2.1, A2.2, A2.3, A2.4

The structural drawings can have a series of sheets that are numbered such as:

- S1.1, S1.2
- S2.1, S2.2, S2.3
- S3.1, S3.2, S3.3, S3.4, S3.5

The decimal sheet-numbering system can be divided even further by adding .01, .02, .03 to the existing numbers as needed. For example, additional pages in the series of S3.1 are numbered S3.1.01, S3.1.02, S3.1.03.

## Coordinating Details and Sections

Now that a page-numbering system is established, you need to coordinate the elements of drawings between sheets. Figure 22.5 shows some examples of how cutting-plane line symbols correlate to the drawing. Construction details and sections are commonly labeled in a similar manner. The details might be numbered in consecutive order and correlated to the page where the detail is found as shown in Figure 22.7. Sections are commonly labeled with letters in alphabetical order, but some companies use numbers. Details are generally labeled with numbers. The detail identification symbol is similar to the cutting-plane symbol, except the solid-filled triangle is omitted. Compare the cutting-plane symbols in Figure 22.5 with the detail identification symbols in Figure 22.7.

## Laying Out Details and Sections

Detail and section drawings present details of all structural connections in the project. Detail and section drawings display the relationship between connected structural members and can contain common assembly and clearance dimensions. Steel shop drawings are produced from the connection details found in the detail and section drawings. Steel shop drawings show views and dimensions for the fabrication of each piece found in the details and section drawings of structural connections. Detail and section drawings can be placed within the drawing where they relate, if space is available. For example, the foundation details and sections can be on the same sheet as the foundation plan if they can be placed there clearly and still maintain a drawing that is easy to read and well organized.

If there is not enough space on the same sheet, then the details and sections can be placed on other sheets. Details should be grouped together and organized from left to right and top to bottom in an aligned, orderly manner. If the details are numbered, they should be organized in numerical order. The sections also should be grouped together and organized from left to right and top to bottom. If the sections are labeled with letters, they should be placed in alphabetical order.

## STRUCTURAL DRAFTING RELATED TO CONSTRUCTION SYSTEMS

Different types of construction methods relate directly to the materials to be used, the area of the country where the construction takes place, the type of structure to be built, and even the office practices of the architect or engineer where the drawings are created. The structural drafter should have knowledge of construction materials and techniques. This chapter introduces these techniques and materials. Additional resources should be used for reference, because each construction method discussed has volumes of general and vendor information available. Another valuable way to learn about construction is to visit job sites to talk to contractors and see firsthand how buildings are constructed.

## CONCRETE CONSTRUCTION

**Concrete** is a mixture of Portland cement, sand, gravel (stones, crushed rock), and water. This mixture is poured into **forms** that are built of wood or other materials to contain the mix in the desired shape until it is hard. Concrete is a fundamental material used for building foundations. The **foundation** is the system used to support the building loads and is usually made up of walls, footings, and piers. The term **foundation** is used in many areas to refer to the footing. The **footing** is the lowest member of the foundation system used to spread the loads of the structure across supporting soil. Concrete is also used in commercial applications for wall and floor systems. Residential buildings use concrete foundations with or

without steel reinforcing, whereas commercial buildings usually use steel-reinforced concrete, depending on the structural requirements.

Earth is generally excavated before a concrete structure is built. **Excavation** refers to removing earth for construction purposes. Before a concrete structure can be built, earth usually needs to be excavated down to firm, undisturbed supporting soil. Detailed engineering specifications are often placed on the drawing identifying the amount of bearing pressure required. The **bearing pressure** is normally the number of pounds per square foot of pressure the soil is engineered to support. A concrete material symbol can be used when drawing foundations in section view as shown in Figures 22.7 and 22.8. Concrete slabs are also normally found on the foundation drawings. A **slab** is a concrete floor system, typically made of poured concrete at ground level. Concrete slabs also normally need to be constructed on firm, undisturbed soil, with engineering specifications provided. In many cases, compacted gravel is specified below the concrete slab. The gravel provides for a level or accurate slope surface on which to pour the concrete slab, and it provides for compaction as needed. A concrete material symbol can be used when drawing slabs, and a gravel material symbol can be used in section view as shown in Figure 22.7. A drawing note representing gravel under the slab might read:

4" MIN. 3/4 MINUS COMPACTED GRAVEL OVER FIRM UNDISTURBED SOIL

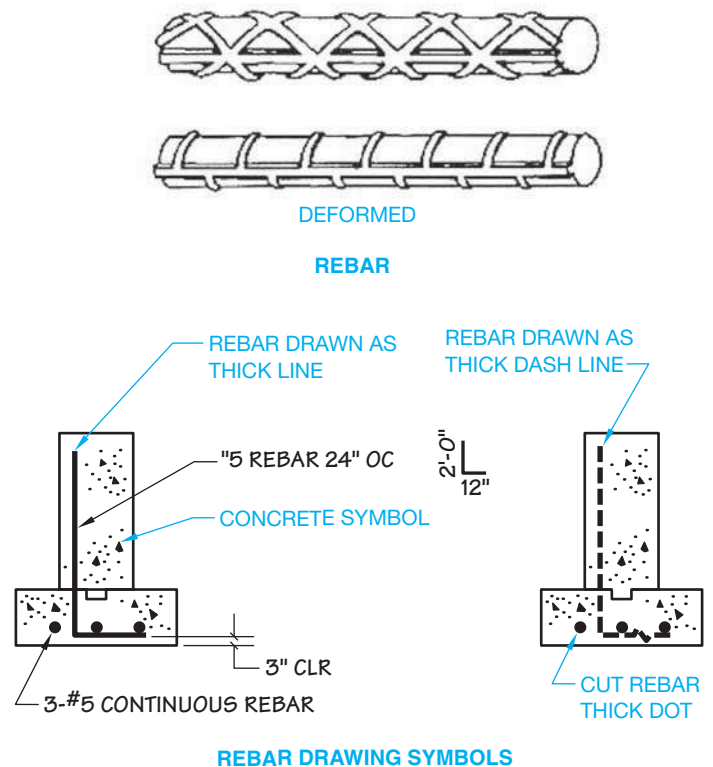


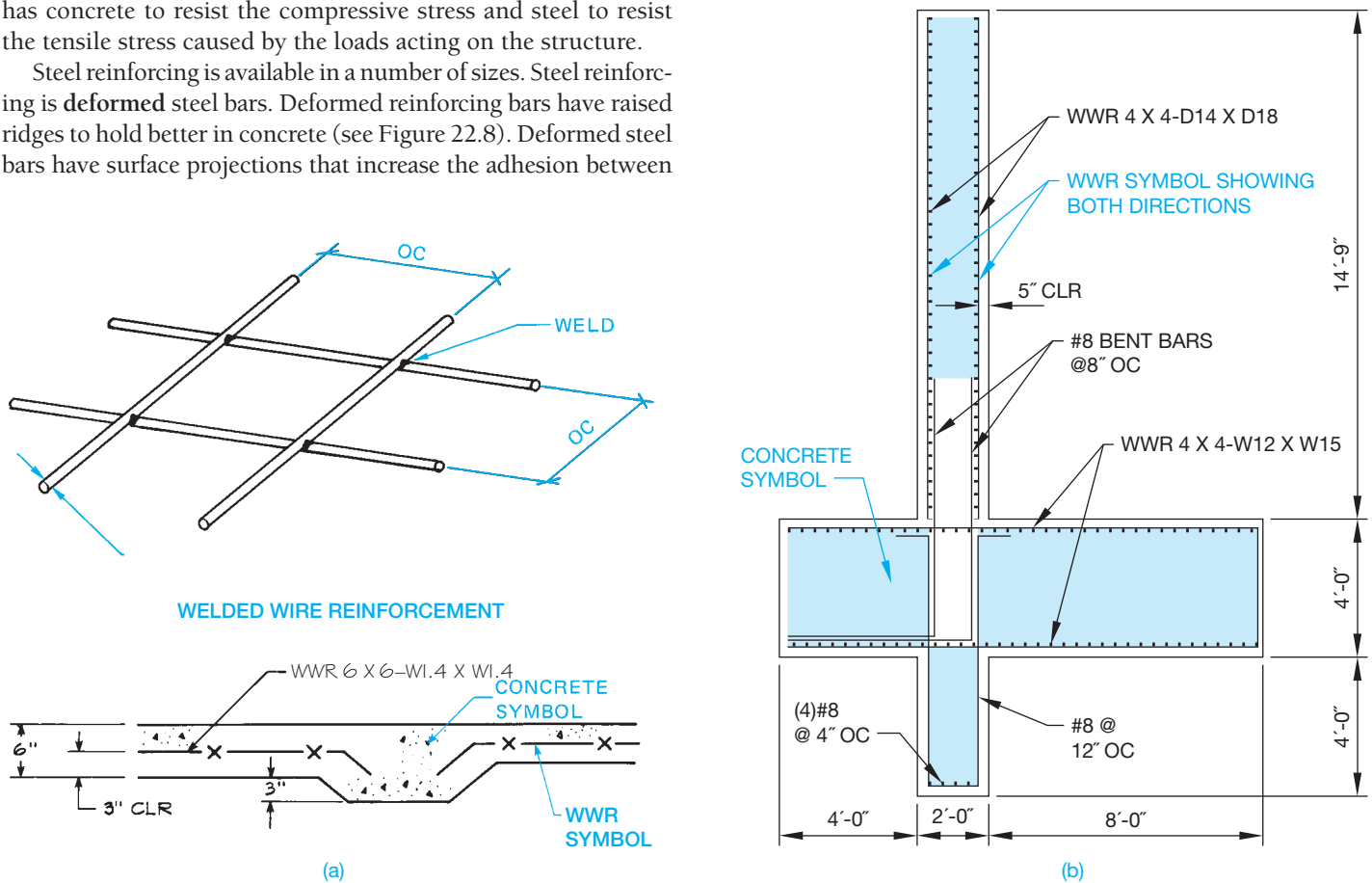
FIGURE 22.8 Representation of reinforcing bars (rebar). © Cengage Learning 2012

Concrete can be poured in place at the job site, formed at the job site and lifted into place, or formed off-site and delivered ready to be erected into place. Concrete alone has excellent compression qualities. Steel added to concrete improves the tension properties of the material. Concrete poured around steel bars placed in the forms is known as **reinforced concrete**. The steel bars are referred to as **rebar**. Steel is the best choice for reinforcing concrete because its coefficient of thermal expansion is almost the same as cured concrete. The resulting structure has concrete to resist the compressive stress and steel to resist the tensile stress caused by the loads acting on the structure.

Steel reinforcing is available in a number of sizes. Steel reinforcing is **deformed steel bars**. Deformed reinforcing bars have raised ridges to hold better in concrete (see Figure 22.8). Deformed steel bars have surface projections that increase the adhesion between

the concrete and steel (see Figure 22.8). Steel reinforcing bars are sized by number, starting at #3, which is 3/8" in diameter, and increasing in size at approximately 1/8" intervals to #18, which is 2-1/4" in diameter. No. 4 rebar is 1/2" in diameter.

**Welded wire reinforcement (WWR)** is another steel concrete reinforcing method. Welded wire reinforcement is steel wires spaced a specified distance apart in a square grid, and the wires are welded together as shown in Figure 22.9.



(c)

**FIGURE 22.9** Welded wire reinforcement. (a) Welded wire reinforcement wire diameter and spacing and use in a concrete slab detail. (b) Welded wire reinforcement represented in a structural section. (c) Welded wire reinforcing being used on a construction project. © Cengage Learning 2012



Figure 22.9a shows the diameter and spacing of welded wire reinforcing and a detail drawing of a concrete slab application. Figure 22.9b shows welded wire reinforcing used in a structural detail. Figure 22.9c shows welded wire reinforcing being used on a construction project. Welded wire reinforcement is specified by giving the spacing of the wire grid, such as 6"  $\times$  6", which means 6" on center (OC) each way, followed by the wire type and size of the wires used in the spacing. Wire spacing can be square or rectangular.

The wire type is given as plain or deformed. **Plain wire** is smooth and is designated with a W, and deformed wire is designated with a D. Deformed steel reinforcing was described earlier. A few of the available wire sizes are W1.4, D1.4, W2.9, D2.9, W11, D11, W15, D15, W20, D20, W45, and D45. Wires are available in many sizes from W1.4 (3/16" diameter) to W45 (3/4" diameter). Most wire sizes are available as either plain or deformed. The wire size numbers relate to the wire area. The wire area is determined by dividing the wire designation by 100—for example, W1.4 is .014 sq. in. ( $1.4 \div 100 = .014$ ), and W45 is .45 sq. in. The welded wire reinforcement grid can have equally spaced wires and the same wire size, or the spacing and size can be different each way. Sample welded wire reinforcement callouts are written

WWR 6  $\times$  6-W15  $\times$  W15

or

WWR 4  $\times$  18-D20  $\times$  W8

Metric welded wire reinforcement specifications have an M preceding the W or D, and the wire area is given in square millimeters. The metric equivalent for a W2.9-inch wire is MW19, for example. The wire spacing is given in millimeters. A metric welded wire reinforcement callout is

WWR 102  $\times$  102-MW20  $\times$  MW20

Welded wire reinforcement is purchased in sheets. Sheet sizes can vary, but they are normally 8'  $\times$  15' and 8'  $\times$  20', and some can go to 12' widths and 40' lengths, depending on shipping and handling equipment to lift and move bundles of sheets. Sheet sizes can also be controlled by state requirements, where restrictions exist for greater than standard loads of 8'  $\times$  40' and 40,000 lbs. Appendix T provides a list of inch and metric welded wire reinforcement sizes.

## STANDARDS

**ASTM** The American Society of Testing Materials (ASTM) ([www.astm.org](http://www.astm.org)) document A615/A615M, *Standard Specification for Deformed and Plain Carbon-Steel Bars for Concrete Reinforcement*, provides standards related to steel reinforcing bars. ASTM A496/A496M, *Standard Specification for Steel Wire, Deformed, for Concrete Reinforcement*, and ASTM A497/A497M, *Standard Specification for Steel Welded Wire Reinforcement, Deformed, for Concrete*, provide standards related to welded wire reinforcement.

**CRSI** Consult the *Manual of Standard Practices*, published by the Concrete Reinforcing Steel Institute (CRSI) ([www.crsi.org](http://www.crsi.org)), for complete information and examples related to steel concrete reinforcing.

**WRI** Refer to the Wire Reinforcement Institute (WRI) ([www.wirereinforcementinstitute.org](http://www.wirereinforcementinstitute.org)) documents *TECH FACTS, Excellence Set in Concrete*, for detailed information about welded wire reinforcement. Appendix S in this textbook gives concrete reinforcing bar specifications, and Appendix T provides standard welded wire reinforcement specifications for inch and metric applications.

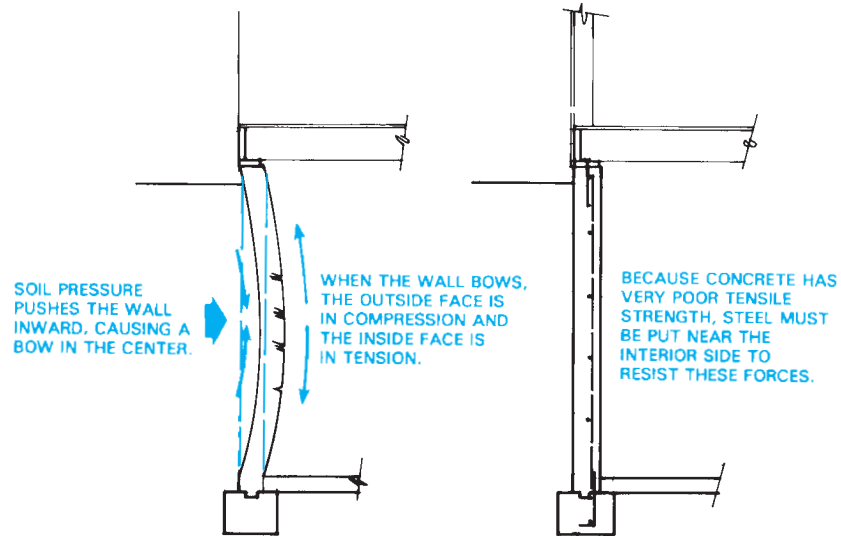
## Poured-in-Place Concrete

Commercial and residential applications for **poured-in-place concrete** are similar except that the size of the **casting** and the amount of reinforcing are generally more extensive in commercial construction. Poured-in-place concrete is the concrete construction method previously described where concrete is poured into forms. The term casting refers to the resulting concrete structure when describing poured-in-place concrete. In addition to the foundation and on-grade (ground) floor systems, concrete is often used for walls, columns, and floors above ground.

Lateral soil pressure acting on concrete structures tends to bend the wall inward, thus placing the soil side of the wall in compression and the interior side of the wall in tension. Steel reinforcing is used to increase the concrete's ability to withstand this **tensile stress** as shown in Figure 22.10. Steel-reinforced walls and columns are constructed by setting steel reinforcing in place and then surrounding it with wooden forms to contain the concrete. Once the concrete has been poured and allowed to set (harden), the forms are removed.

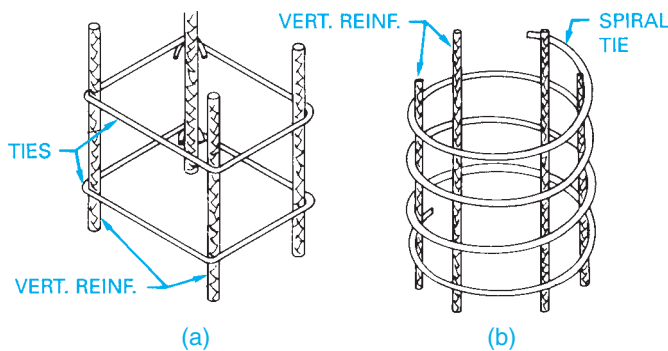
As a structural drafter, you will be required to draw details showing the sizes of the feature to be constructed and steel placement within the structure. This typically consists of drawing the vertical steel and the horizontal ties. **Ties** are wrapped around vertical steel in a column or placed horizontally in a wall or slab to help keep the structure from separating, and they keep the rebar in place while the concrete is being poured into the forms. Figure 22.11 shows two examples of column reinforcing. The drawings required to detail the construction of a rectangular concrete column are shown in Figure 22.12.

Concrete is also used on commercial projects to build aboveground floor systems. The floor slab can be supported by a steel deck or be self-supported. The steel deck system is typically used on structures constructed with a steel frame (see Figure 22.13). Two of the most common poured-in-place concrete floor systems are the **ribbed** and **waffle** floor methods as shown in Figure 22.14. The ribbed system is used in many

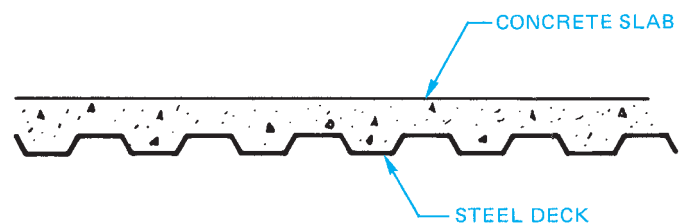


© Cengage Learning 2012

**FIGURE 22.10** Stresses created in a concrete wall from horizontal forces. The wall serves as a beam spanning between each floor, and the soil is the supported load.

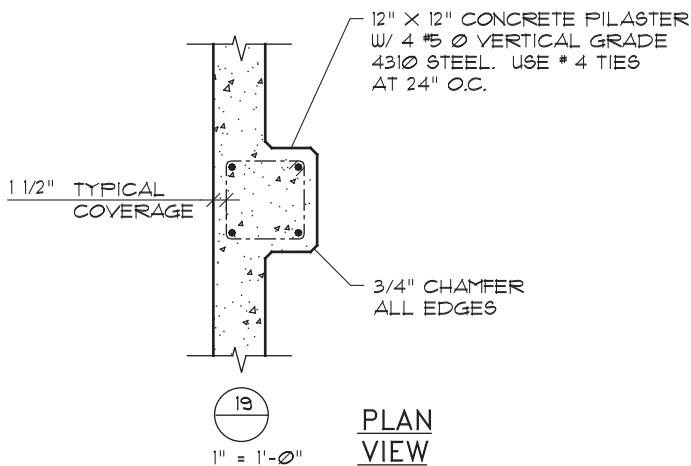


**FIGURE 22.11** Examples of column reinforcing. (a) Square column ties. (b) Round column spiral ties. © Cengage Learning 2012



**FIGURE 22.13** Representation of a steel deck system. © Cengage Learning 2012

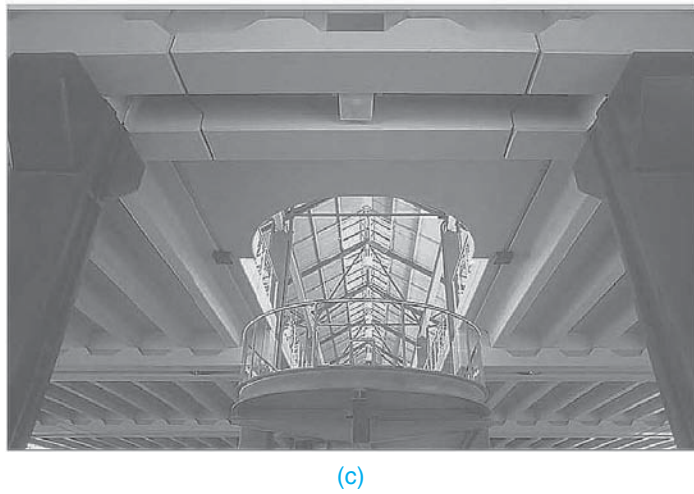
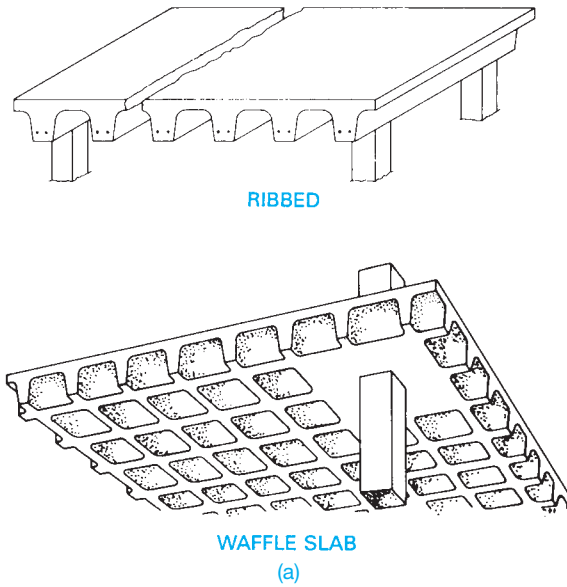
office buildings. The ribs serve as floor joists to support the slab but are actually part of the slab. Joists are horizontal structural members used in repetitive patterns to support floor and ceiling loads. Spacing of the ribs varies, depending on the span and the amount and size of reinforcing. The span is the horizontal distance between two supporting members. The waffle system is used to provide added support for the floor slab and is typically used in the floor systems of parking garages. Figure 22.14b shows waffle system construction, and Figure 22.14c shows ribbed floor system construction.



**FIGURE 22.12** Typical reinforcing for a rectangular concrete column. © Cengage Learning 2012

## Precast Concrete

Precast concrete construction consists of forming the concrete component off-site at a fabrication plant and transporting it to the construction site. Figure 22.15 shows a precast beam being lifted into place. Drawings for precast components must show how precast members are to be constructed and methods of transporting and lifting the member into place. Precast



© Cengage Learning 2012

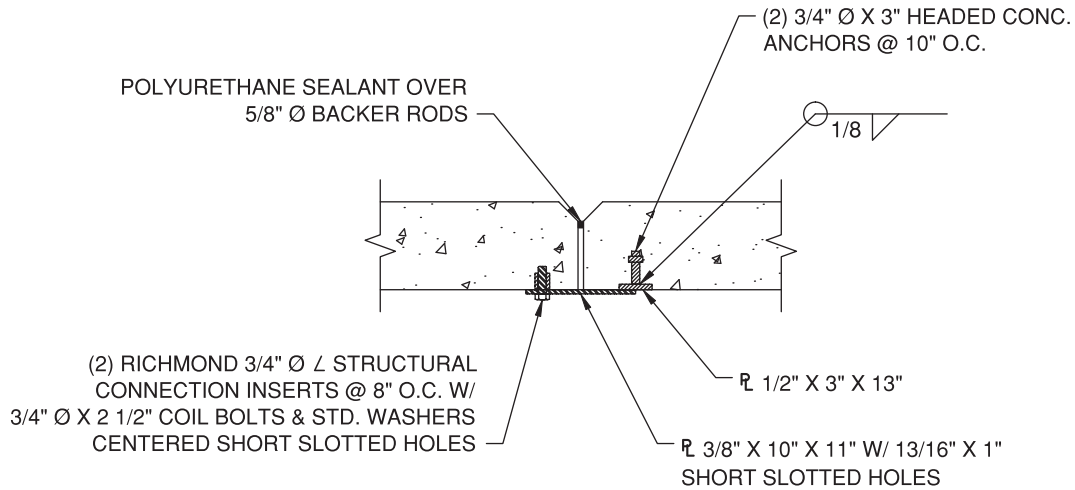
**FIGURE 22.14** (a) Two common concrete floor systems. (b) Waffle system construction. (c) Ribbed floor system construction.



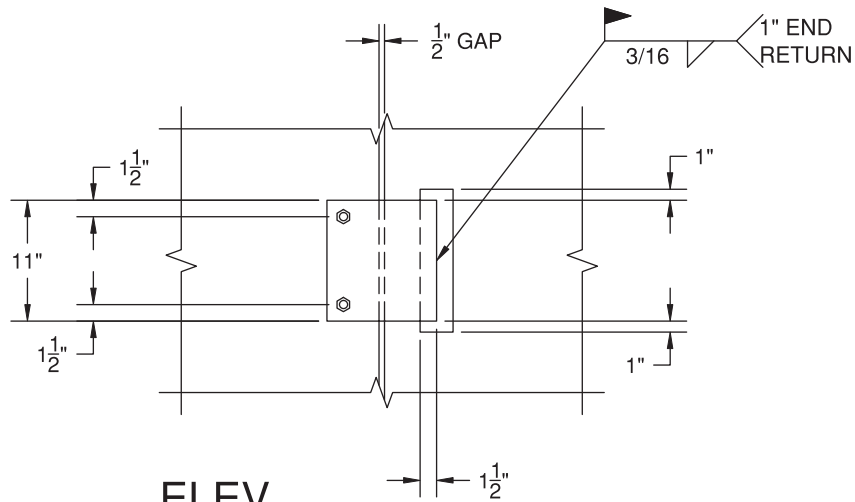
**FIGURE 22.15** Precast concrete beams and panels are often formed off-site, delivered to the job site, and then set into place with a crane. © Cengage Learning 2012

members often have an exposed metal flange so the member can be connected to other parts of the structure. Common details used for wall connections are shown in Figure 22.16.

Many concrete structures are precast and **prestressed**. Concrete is prestressed by placing steel cables, wires, or bars held in tension between the concrete forms while the concrete is poured around them. Once the concrete has hardened and the forms are removed, the cables act like big springs. As the cables attempt to regain their original shape, compression pressure is created within the concrete. The compressive stresses built into the concrete member help prevent cracking and deflection. Prestressed concrete members are generally reduced in size in comparison with the same design features of a standard precast concrete member. Prestressed concrete components are commonly used for the structural beams of buildings and bridges. Figure 22.17a shows the difference between forces being



**PLAN**



**ELEV**

NOTE: CONNECTIONS TO BE SPACED @ 5'-6" O.C. BEGINNING 12" FROM SLAB.

1	<b>PANEL CONNECTOR</b>
3	
SCALE 1" = 1'-0"	

© Cengage Learning 2012

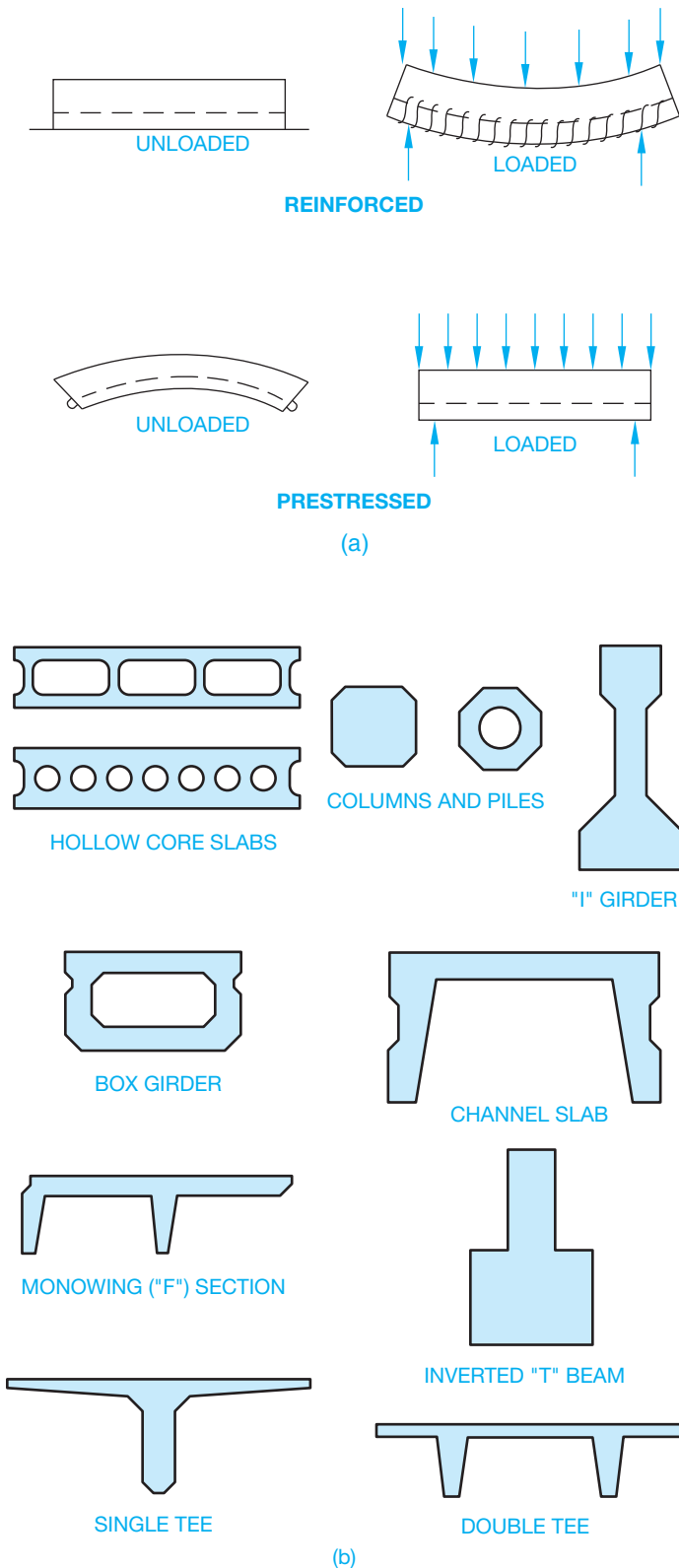
**FIGURE 22.16** Typical panel connection detail.

applied before and after installation on reinforced concrete and prestressed concrete. Common prestressed concrete shapes are shown in Figure 22.17b.

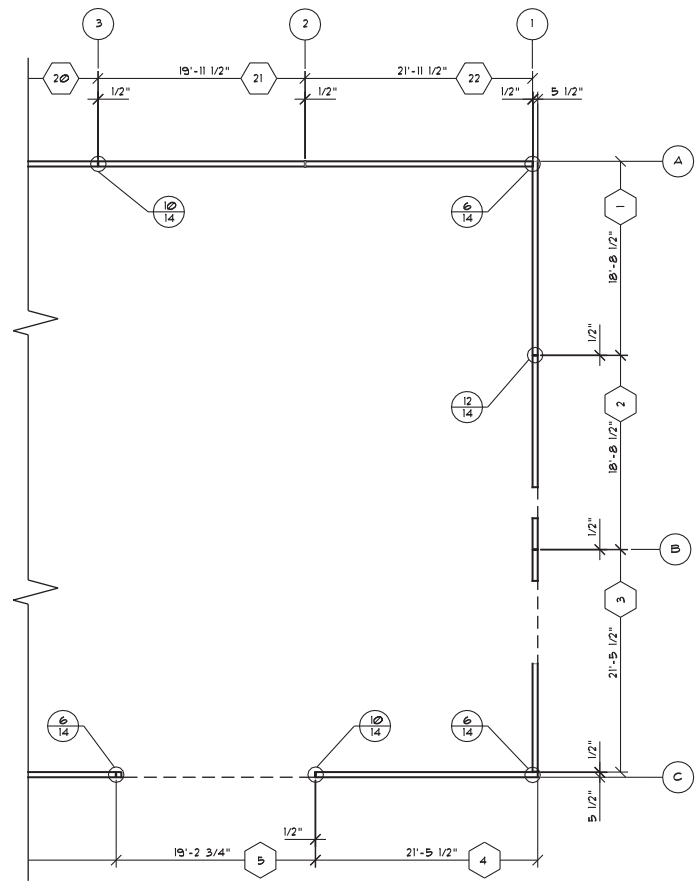
### Tilt-Up Precast Concrete

**Tilt-up construction** is a precast concrete method using formed wall panels that are lifted or **tilted** into place. Panels can be formed and poured either at or off the job site. Forms for a

wall are constructed in a horizontal position and the required steel placed in the form. Concrete is then poured around the steel and allowed to harden. The panel is lifted into place once it has reached its desired hardening and design strength. When using this type of construction, the drafter usually draws a plan view to specify the panel locations as shown in Figure 22.18. The location and size of steel placement and openings are also important as shown in the panel elevation in Figure 22.19. Figure 22.20 shows tilt-up construction projects. Figure 22.20a



**FIGURE 22.17** (a) The difference between forces being applied before and after installation on reinforced concrete and prestressed concrete. (b) Common prestressed concrete shapes. © Cengage Learning 2012



**FIGURE 22.18** Tilt-up panel plan. © Cengage Learning 2012

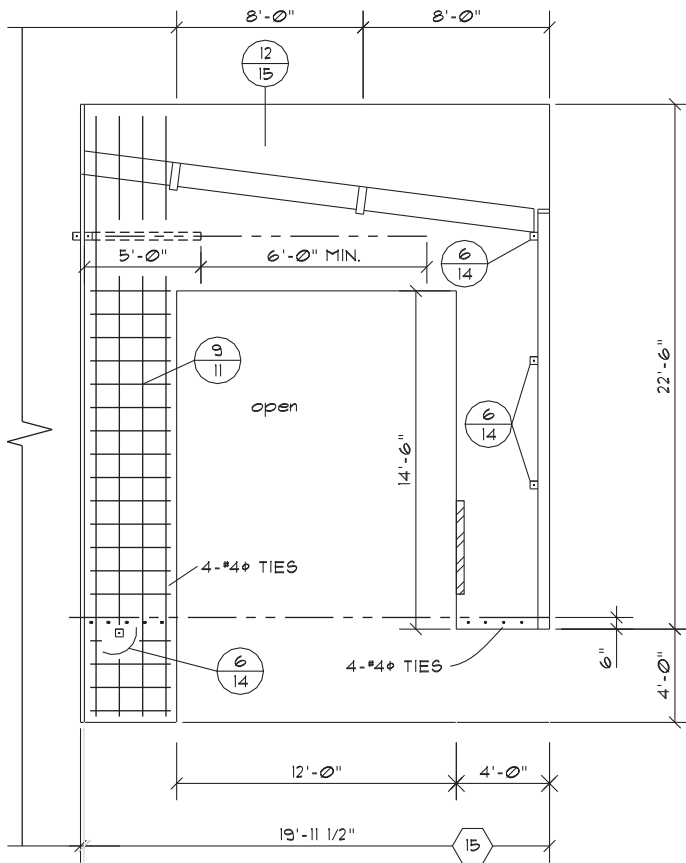
shows tilt-up construction braces. Figure 22.20b shows tilt-up construction forms. Figure 22.20c shows tilt-up panel. Figure 22.20d shows tilt-up panel with rebar and window cutouts.

Figure 22.21 on page 945 shows a precast concrete panel drawing. A precast concrete beam drawing is displayed in Figure 22.22 on page 946, and a precast concrete slab drawing is shown in Figure 22.23 on page 947. Construction details are commonly used in prestressed concrete construction. Figure 22.24 on page 948 shows a precast concrete panel installed on a poured concrete wall and footing.

### Standard Structural Callouts for Concrete Reinforcing

When specifying **anchor bolts (AB)** on a drawing, give the quantity, diameter, type, length, spacing on center (OC), and projection (PROJ) of the thread out of the concrete. An anchor bolt is a bolt embedded in concrete used to hold structural members in place. The quantity can be displayed followed by a dash or in parentheses. The W is the abbreviation for **with** and can also be abbreviated W/. For example,

(12)-3/4" Ø × 12" STD AB 24" OC W/3" PROJ



**FIGURE 22.19** Steel and opening locations specified in precast panel elevation. © Cengage Learning 2012

When specifying rebar on a drawing, give the quantity (if required), bar size, length (if required), spacing in inches on center, horizontal or vertical spacing in inches or millimeters, and bend information (if required). The (if required) note means that this specific information is given only if needed. These specifications are not needed if general space requirements control the application. **Deformed steel rebar** is assumed unless otherwise specified. For example,

- #4 @ 12" OC
- (25)#8 @ 24" OC HORIZ AND 16" OC VERT
- #6 @ 24" OC EA WAY (OR EW)
- #5 @ 16" OC × 12" OC

Notice the at symbol—@—is used in the previous note. This symbol or the word *at* can be used to separate the material specification from the designated spacing. The word *at* or the @ symbol is also sometimes omitted, which is an acceptable option, depending on company or personal preference.

Dimensions of bends are to be provided in feet and inches without the (') and (") marks given. For example,

#5 AT 16" OC VERT W/ 90° × 12 BEND

or the bend diagram can be drawn as shown in Figure 22.25.

When specifying welded wire reinforcement on a drawing, give the designation WWR, the wire spacing in inches OC, and the wire size. For example,

WWR 6 × 6-W1.4 × W1.4

Reinforcing steel rebar lap splices can be shown on the drawing by giving the length of the lap and a lap location dimension. For example,

#5 REBAR 16" OC W/ 24" MIN SPLICE AT FOOTING

Welded wire reinforcement lap splices need not be shown as a specific note on the drawing. However, a general note should clarify the amount of allowable splice overlap, in inches, at the cross wires.

Clear distances should be given from the surface of the concrete to the rebar. This dimension is assumed to be to the edge of the rebar or clarified by the abbreviation CLR, as in 3" CLR. If this dimension is designated to the centerline of the rebar, then OC must be specified.

When structural members are embedded in concrete, the size of holes for rebar to pass through should be specified with the structural member callout. For example,

#5 AT 16" OC W/ 13/16 Ø HOLES

Recommended hole sizes for rebar passing through steel or timber are as follows.

Bar #	Hole Ø	Bar #	Hole Ø
4	11/16	8	1 1/4
5	13/16	9	1 3/8
6	1	10	1 9/16
7	1 1/8		

When rebar must be driven through timber, a tighter hole tolerance is recommended. For example,

#8 REBAR × 6'-0" @ 12" OC W/1-1/8" Ø HOLES AT TIMBER

Timber application for rebar is as follows.

Bar #	Hole Ø	Bar #	Hole Ø
4	9/16	8	1 1/8
5	11/16	9	1 1/4
6	7/8	10	1 7/16
7	1		

Slab thickness, concrete wall, or concrete beam and column cross-sectional dimensions should be given in inches or feet and inches. A complete slab-on-grade callout can read as

4" CONC SLAB ON FIRM UNDISTURBED SOIL OR 4" SAND FILL

or as

6" THICK 3000 PSI CONC SLAB WITH WWR 6 × 6—W2.9 × W2.9 3" CLR AT 4" MIN 3/4" MINUS FILL



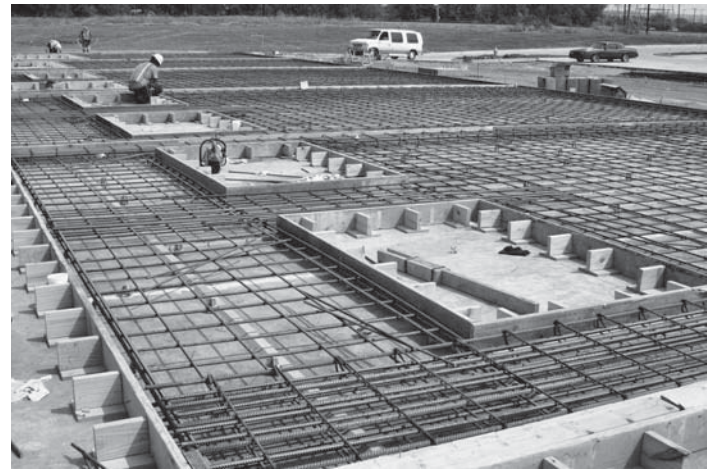
(a)



(b)



(c)



(d)

**FIGURE 22.20** (a) Tilt-up construction braces. (b) Tilt-up construction forms. (c) Tilt-up panel. (d) Tilt-up panel with rebar and window cutouts. All photos courtesy [www.constructionphotographs.com](http://www.constructionphotographs.com)

Concrete footing thickness should be given in inches or feet and inches. The footing width can be given followed by the thickness all in one note. Metric values are in millimeters.

## Concrete Structural Engineering Drawings

Structural engineering drawings show general information that is required for sales, marketing, engineering, or erection

purposes. Concrete structures are drawn in plan (top) view, elevation (side) view, or sectional views at a scale that is dependent on the size of the structure, the amount of detail, and the sheet size. Dimensions and notes are used to completely describe the construction characteristics. Concrete material symbols are used where appropriate. Rebar is shown as a very thick line or a thick dashed line in longitudinal view or as a round dot where the bar appears cut. Figure 22.26 on pages 949–950 illustrates a concrete

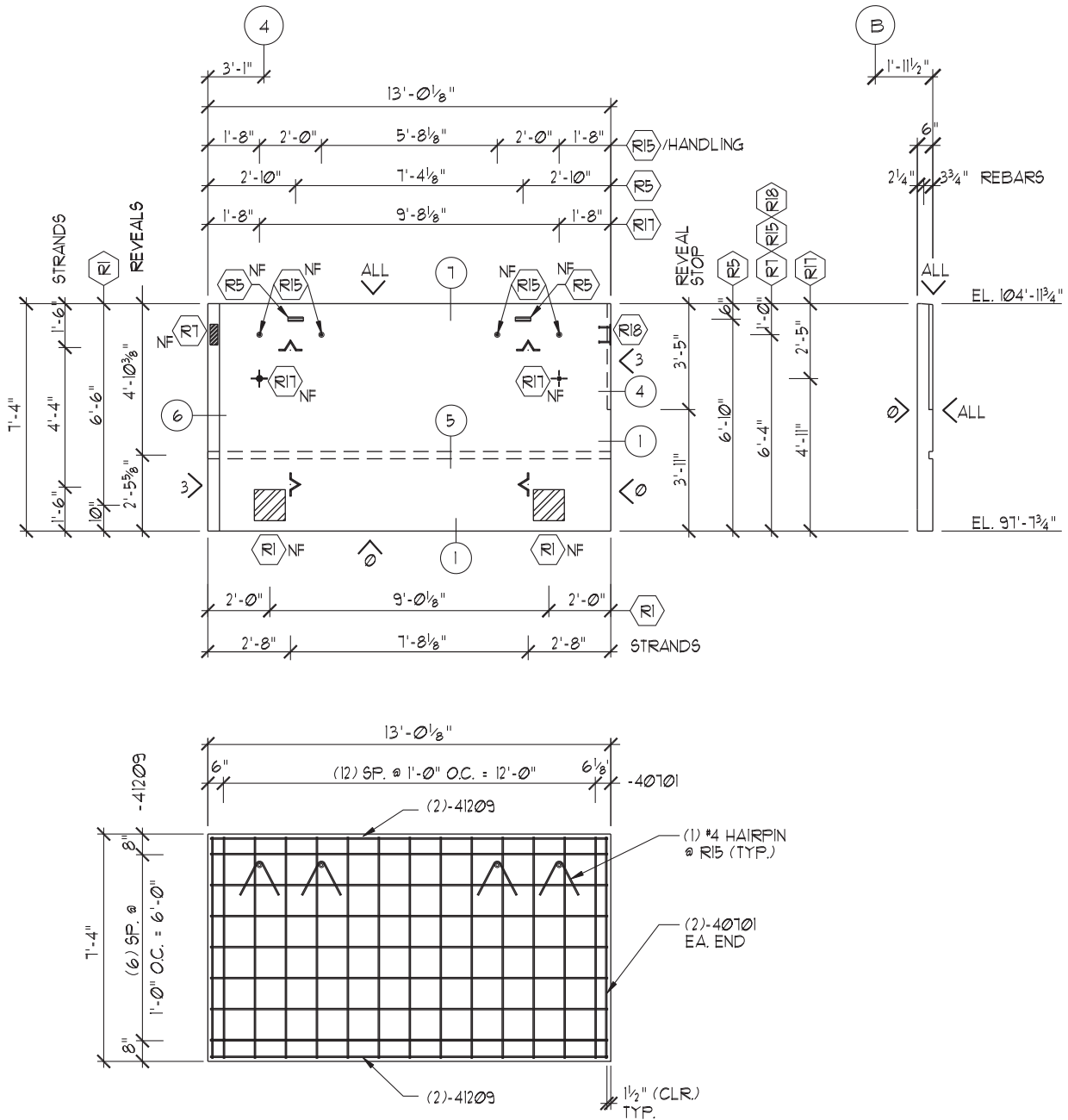


FIGURE 22.21 Precast concrete panel drawing.

Courtesy/Morse Bros., Inc.

foundation and related concrete and concrete block details as a typical example of the type of concrete drawings created by the structural drafter.

### CONCRETE BLOCK CONSTRUCTION

A **concrete block** is also called a **concrete masonry unit (CMU)**, cement block, or foundation block. A concrete block is a rectangular concrete form used in construction. Concrete

block construction is often used for residential foundations but is also used in aboveground construction. In commercial applications, concrete blocks are used to form the wall systems for many types of buildings. Concrete blocks provide a durable construction material and are relatively inexpensive to install and maintain. In residential and light commercial applications, foam-filled blocks provide excellent insulating characteristics and are often used in desert climates.

Blocks are commonly manufactured in nominal **size modules** of 8 × 8 × 16 in., 4 × 8 × 16 in., or 6 × 8 × 16 in.



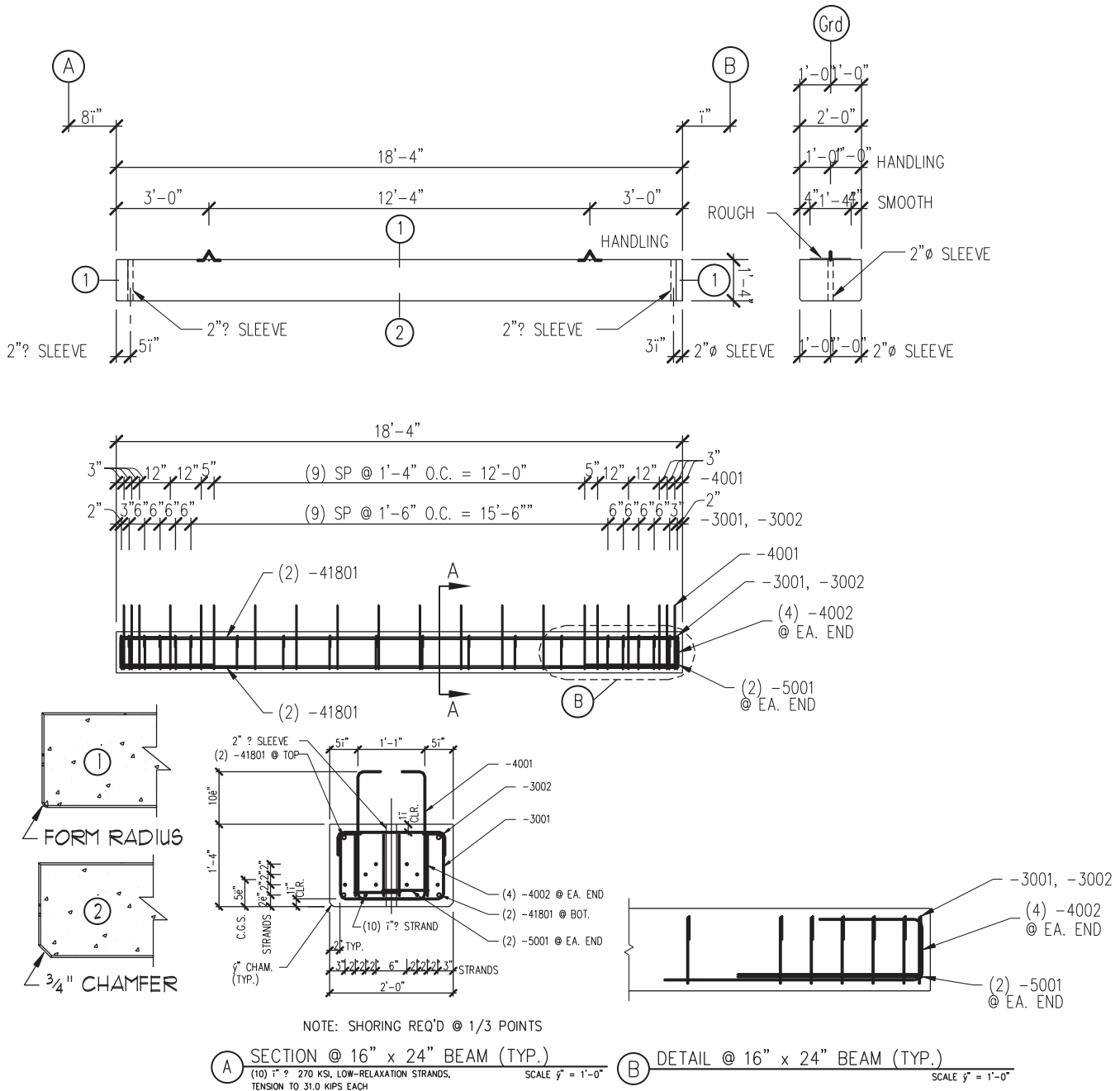


FIGURE 22.22 Precast concrete beam drawing.

The metric conversion of a nominal 8 × 8 × 16 in. concrete masonry unit is 200 × 200 × 400 mm. The actual size of the block is smaller than the nominal size, so mortar joints can be included in the final size. A mortar joint is also called a grout joint. Mortar is a combination of cement, sand, and water used to bond masonry units together. Although the building designer determines the size of the structure, it is important that the drafter be aware of the modular principles of concrete

block construction. Wall lengths, opening locations, and wall and opening heights must be based on the modular size of the block being used. Failure to maintain the modular layout can result in a tremendous increase in labor costs to cut and lay the blocks.

The drafter's responsibility when working with concrete block structures is also to detail steel reinforcing patterns. Concrete blocks are often reinforced with a wire mesh at every

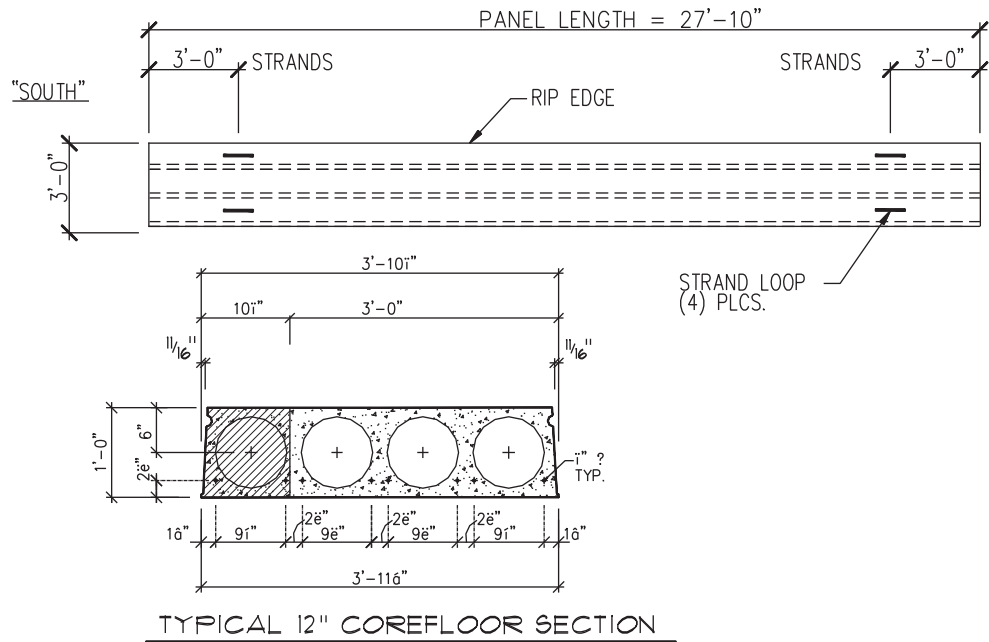


FIGURE 22.23 Precast concrete slab drawing.

Courtesy Mouse Bros., Inc.

other course of blocks. Where the risk of seismic activity must be considered, concrete block structures are often required to have reinforcing steel placed within the wall to help tie the blocks together. The steel is placed in a block that has a channel or cell running through it. This cell is then filled with grout or concrete to form a **bond beam** within the wall. The bond beam solidifies and ties the block structure together. A typical bond beam concrete block structure is detailed in Figure 22.27 on page 950. Figure 22.28 on page 951 shows typical concrete block sizes and reinforcing methods. Openings for windows and doors require steel reinforcing for both poured-in-place and concrete block construction (see Figure 22.29 on page 952).

When the concrete blocks are required to support a load from a beam, a **pilaster** is often placed in the wall to help transfer the beam loads down the wall to the footing. A pilaster is a reinforcing column built into or against a masonry or other wall structure. Pilasters are also used to provide vertical support to the wall when the wall is required to span long distances. Examples of pilasters are shown in Figure 22.30 on page 952. A structural detail is shown in Figure 22.31 on page 953.

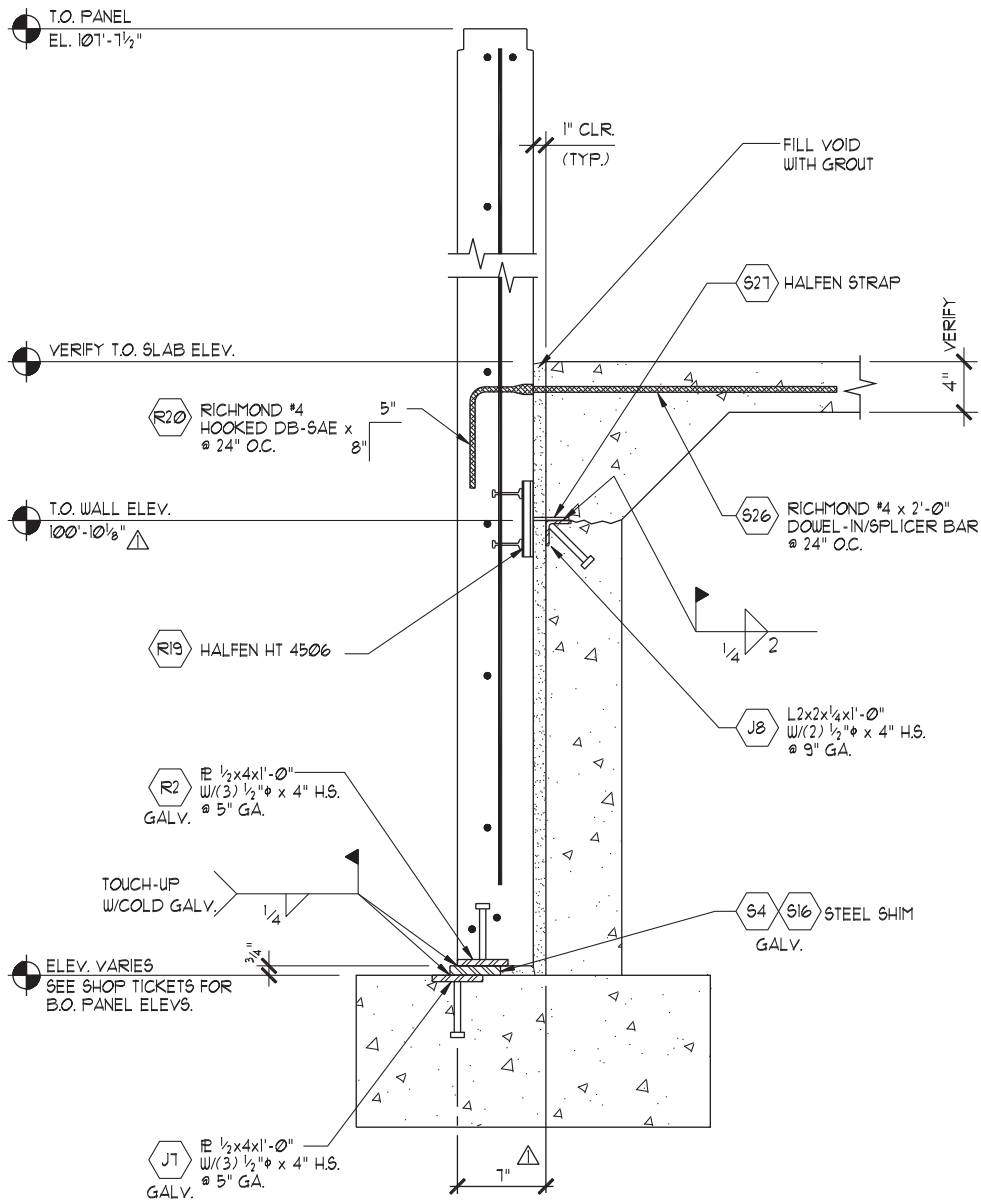
## WOOD CONSTRUCTION

**Wood-frame construction**, also referred to as **light-frame construction**, uses **dimensional lumber** nailed together to form a supporting framework and covered with a variety of surfacing materials. Dimensional lumber is wood construction members

that have been planed and cut to standardized width and depth specified in inches or millimeters. Wood-frame construction is typical in residential construction and is also used in commercial construction applications, especially for multifamily dwellings and office buildings. Other commercial uses include partition framing, upper-level floor framing, and roof framing. Residential and commercial wood wall construction is essentially the same, with the main difference often being the type of covering used. In commercial applications, wood walls can require special finishes to meet fire protection requirements as shown in Figure 22.32 on page 953.

**Joists, trusses, and panelized systems** are the most commonly used wood roof framing systems. These systems allow for the members to be placed 16, 24, or 32 in. (400–800 mm) OC. Figure 22.33 on page 954 shows a truss roof system drawing. Panelized roof systems use beams placed 20 to 30 ft. (6000–9000 mm) apart with smaller beams called **purlins** placed between the main beams on 8 ft. (2400 mm) centers. Joists that are 2 or 3 in. (75 mm) wide are placed between the purlins at 24 in. (600 mm) OC. The roof is then covered with plywood sheathing. The dimensional values given in this discussion are examples. Actual dimensions must be determined by structural engineering based on the building design. Figure 22.34 on page 954 shows an example of how a panelized roof system is constructed. Figure 22.35 on page 955 shows a roof framing plan for a panelized roof system.

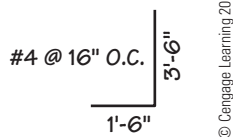
When wood-frame construction joins concrete or concrete block construction, a rigid connection between the two systems is required. Figure 22.36 on page 956 shows methods of connecting wood to concrete block.



SECTION AT LOADING DOCK PANELS  
1" = 1'-0" REF. DBA 9K-N

FIGURE 22.24 Precast concrete panel and concrete wall, footing, and slab detail drawing.

Courtesy Morse Bros., Inc.

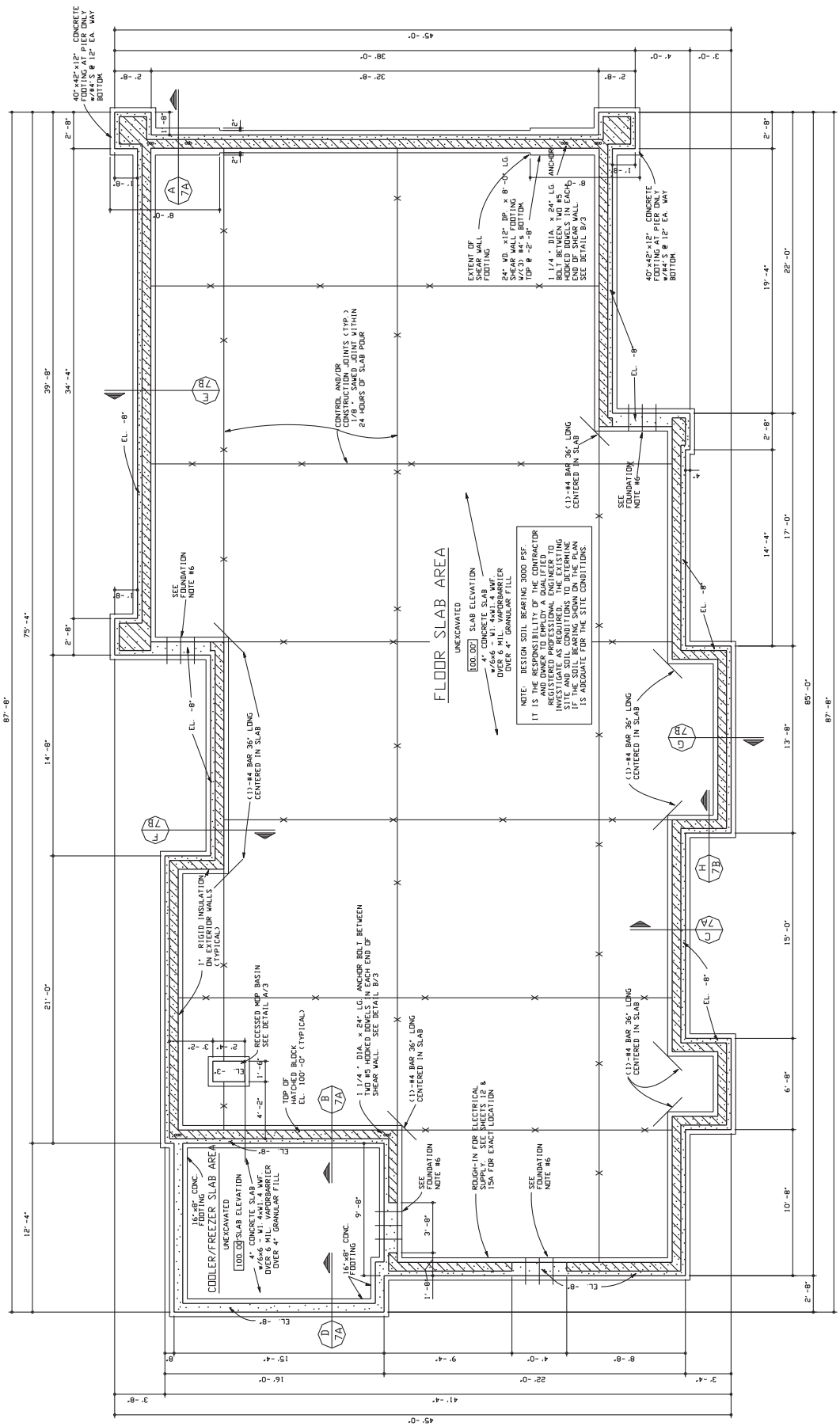


© Cengage Learning 2012

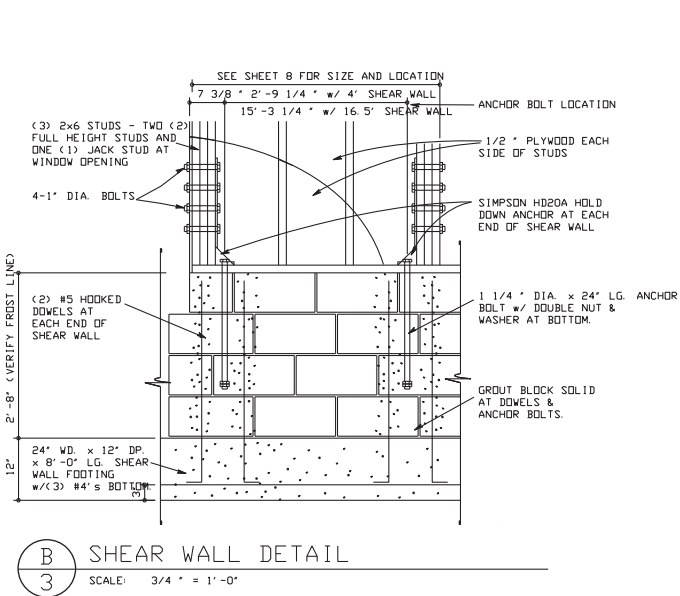
FIGURE 22.25 Rebar bend diagram.

## Heavy Timber Construction

Large wood members are sometimes used for the structural frame of a building. This method of construction is used for appearance and structural purposes and when material is available to suit the application. Heavy timbers have structural advantages for short spans and excellent fire retardant qualities.



**FIGURE 22-26** Concrete foundation and related concrete and concrete block details. © Cengage Learning 2012



- FOUNDATION NOTES**
1. ALL FOOTINGS ARE 20" x 8" w/2-#4 BARS, CONTINUOUS, UNLESS NOTED OTHERWISE.
  2. VERIFY DEPTH OF FOOTING BELOW GRADE WITH LOCAL CODE.
  3. CONCRETE BLOCK COURSING STARTS AT TOP OF FOOTING WITH CRS #1.
  4. SEE ELECTRICAL SHEETS FOR LOCATIONS OF CONDUIT RUNS.
  5. SEE PLUMBING PLAN FOR LOCATION OF PIPING RUNS.
  6. AT DOOR OPENINGS:
    - PROVIDE 3-#4 BARS AT 12" ON CENTER x 2'-0" LONG, w/8" PROJECTION AS INDICATED ON FOUNDATION PLAN.
    - POUR SLAB THROUGH OPENING.
    - PROVIDE CONTROL JOINT CENTERED ON WALL.
  7. ALL FOOTINGS ARE DESIGNED FOR 3000 P.S.F. SOIL BEARING PRESSURE. VERIFY SOIL BEARING CAPACITY BEFORE PLACING FOOTINGS.
  8. TYPICAL IN STUD WALLS, GROUT BLOCK SOLID.

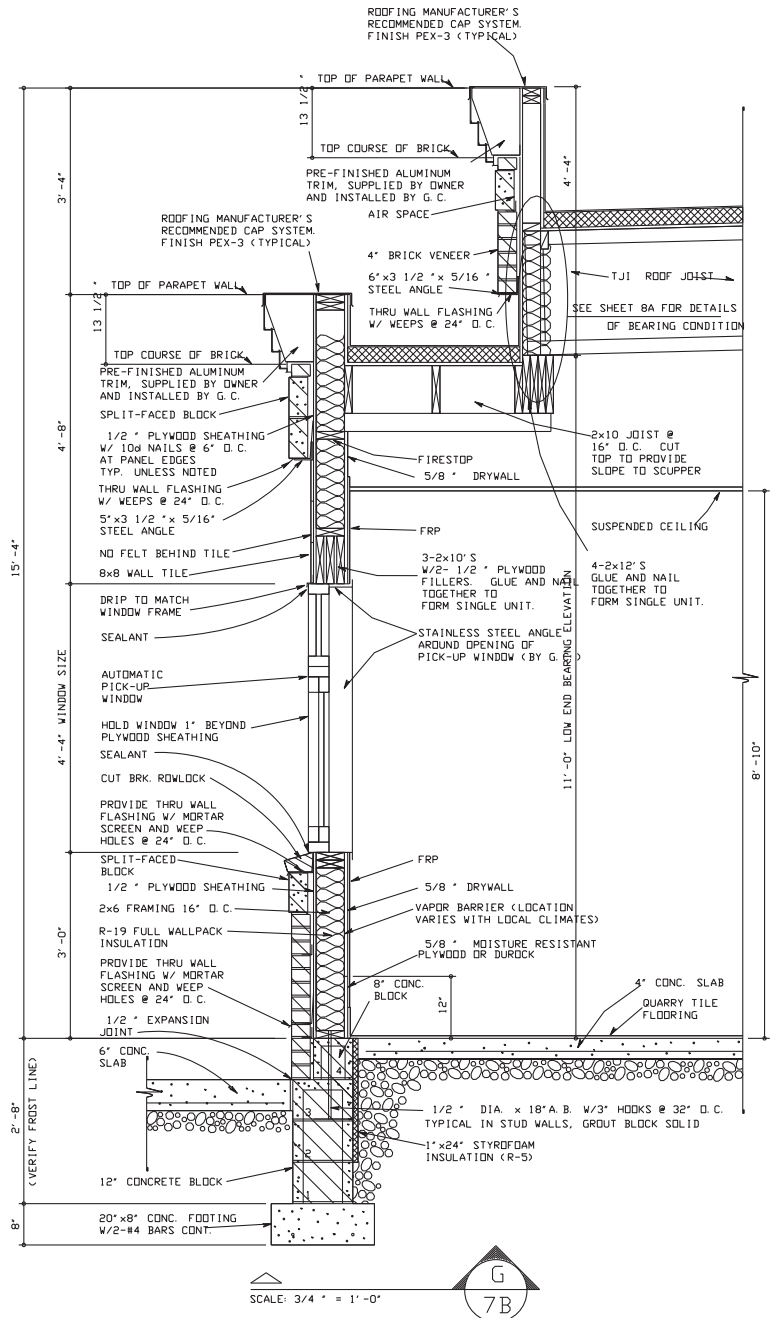


FIGURE 22.26 (Continued)

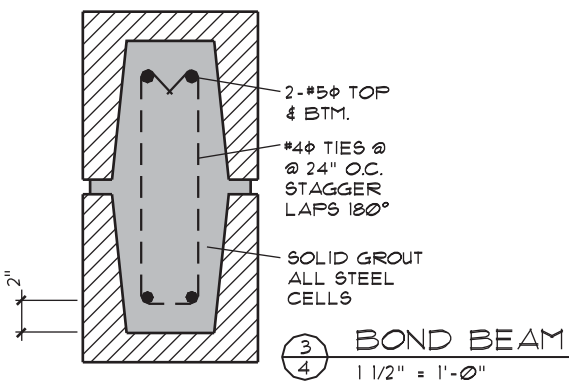


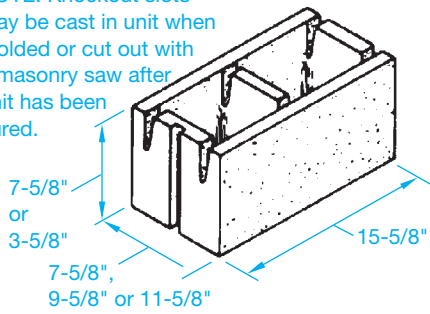
FIGURE 22.27 Concrete block bond beam reinforcing detail.

In a fire, heavy wood members char on the exposed surfaces while maintaining structural integrity long after a steel beam of equal size has failed. Figure 22.35 shows a heavy timber roof framing plan.

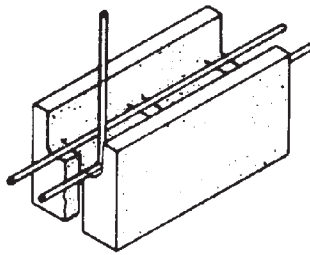
## Laminated Beam Construction

It is difficult and often impossible to produce large-size wood timbers in long lengths, especially when lumber is currently sawn from smaller and smaller logs. When long-span wood

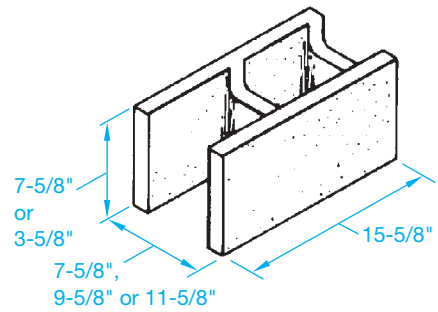
NOTE: Knockout slots may be cast in unit when molded or cut out with a masonry saw after unit has been cured.



(a) Standard unit with end and web knockout slots.

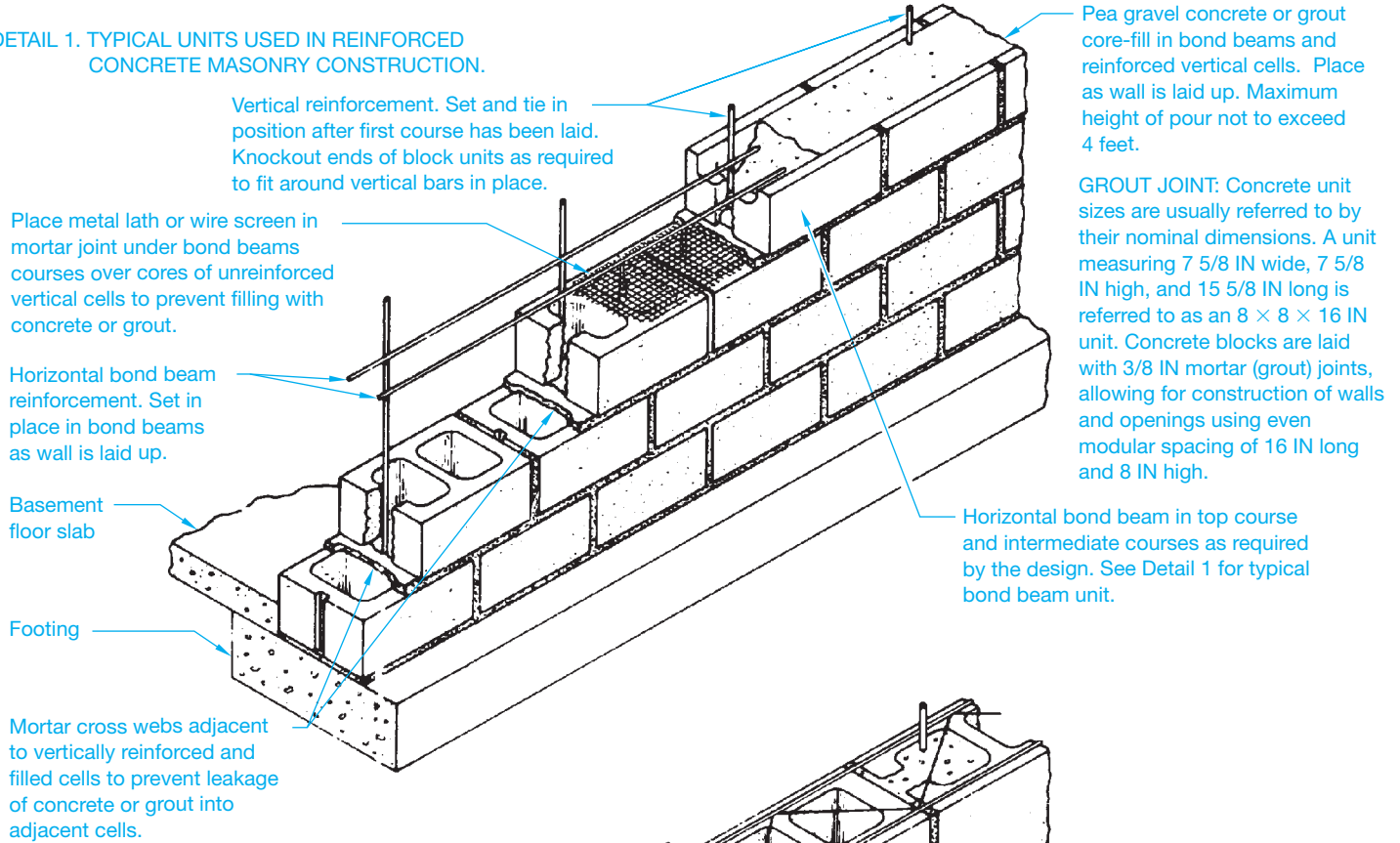


(b) Standard unit with sections of end and cross webs removed to permit placement of reinforcing.



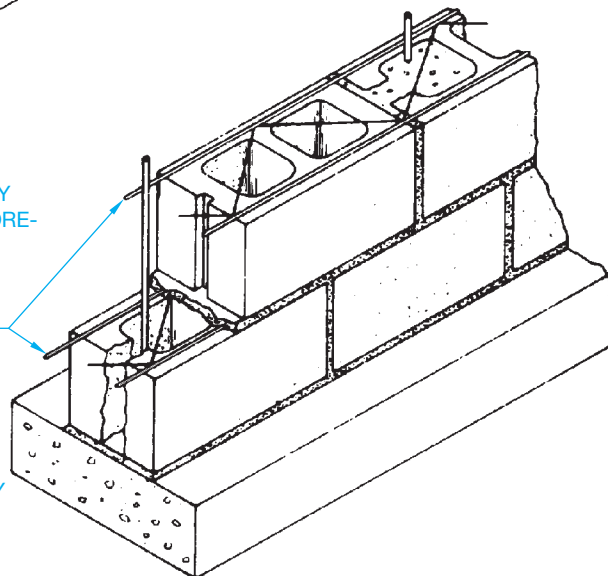
(c) Open-end unit with horizontal channels.

DETAIL 1. TYPICAL UNITS USED IN REINFORCED CONCRETE MASONRY CONSTRUCTION.



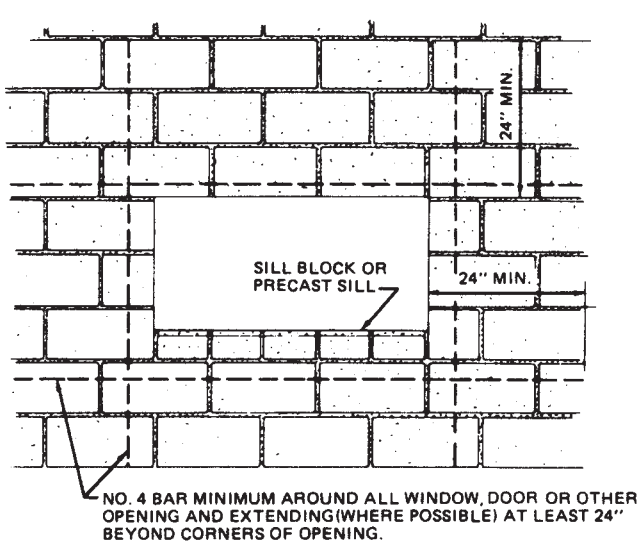
DETAIL 2. TYPICAL REINFORCED CONCRETE MASONRY CONSTRUCTION—REINFORCEMENT AND CORE-FILL PLACED AS WALL IS LAID UP.

Prefabricated trussed-type horizontal joint reinforcement with deformed high-tensile strength steel longitudinal rods in horizontal mortar joints at spacing as required.

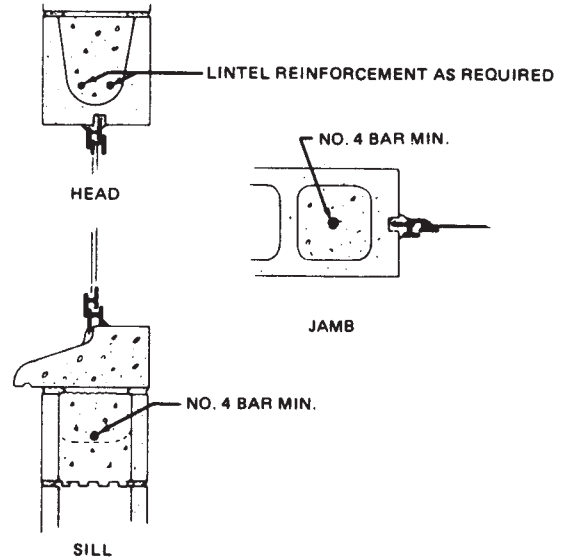


DETAIL 3. TYPICAL REINFORCED CONCRETE MASONRY CONSTRUCTION USING HORIZONTAL JOINT REINFORCEMENT IN LIEU OF BOND BEAMS TO PROVIDE LATERAL REINFORCEMENT.

FIGURE 22.28 Suggested construction details for reinforced concrete masonry foundation walls. Courtesy National Concrete Masonry Association



RECOMMENDED REINFORCEMENT AROUND OPENINGS



TYPICAL STEEL BASEMENT WINDOW DETAILS

FIGURE 22.29 Typical reinforcing and window detail at opening in reinforced concrete masonry. Courtesy National Concrete Masonry Association

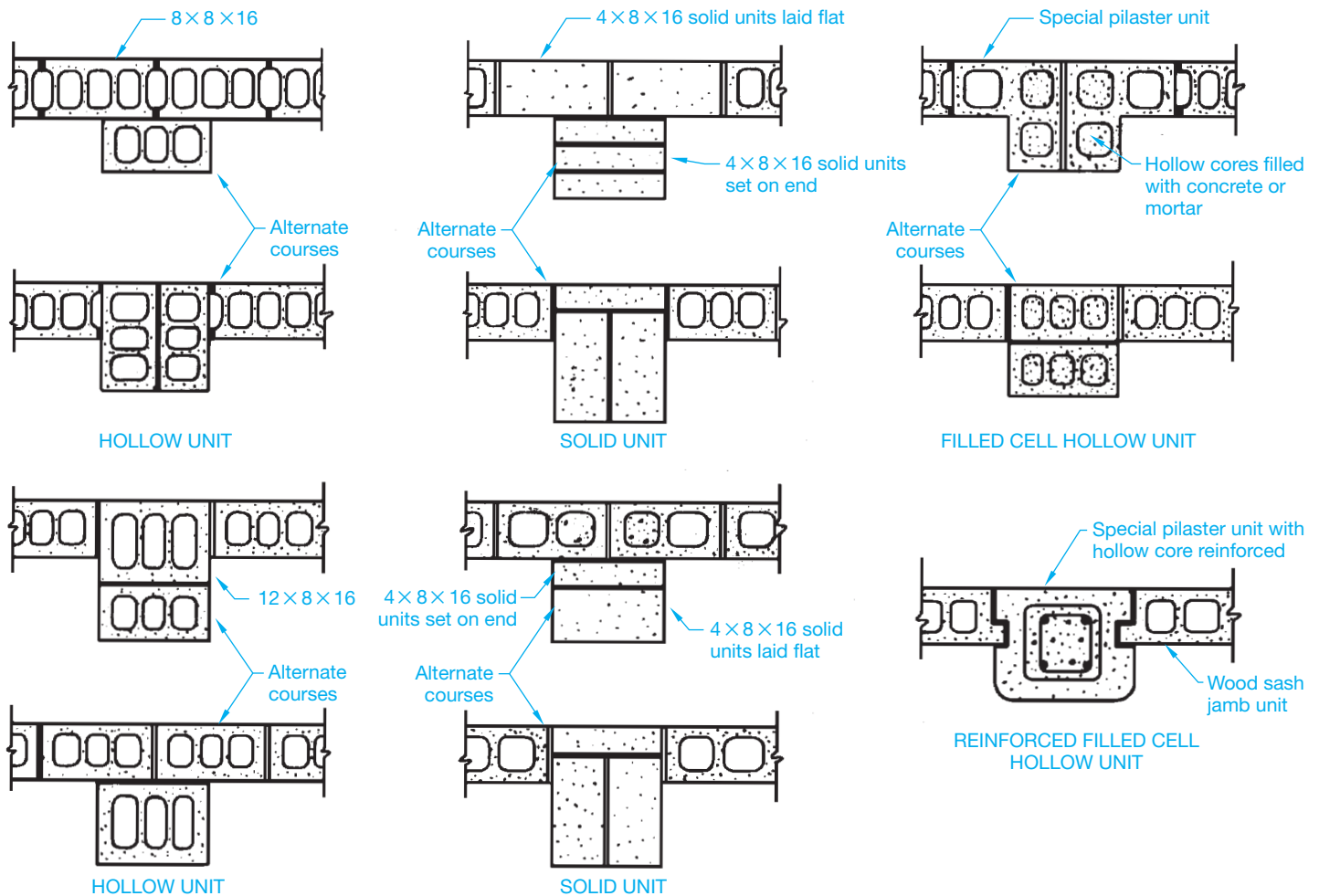


FIGURE 22.30 Typical concrete masonry pilaster designs. Courtesy National Concrete Masonry Association

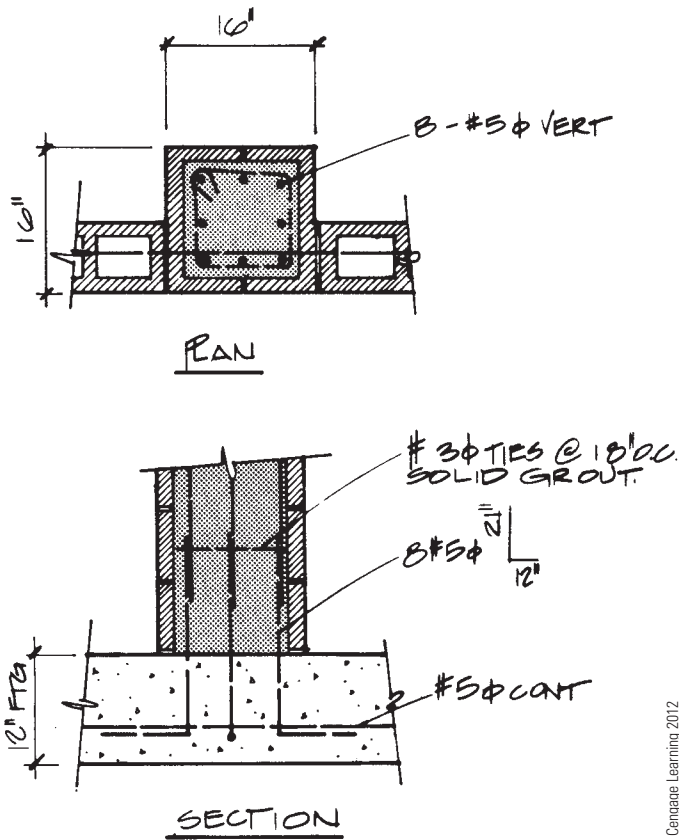


FIGURE 22.31 Reinforced pilaster detail.

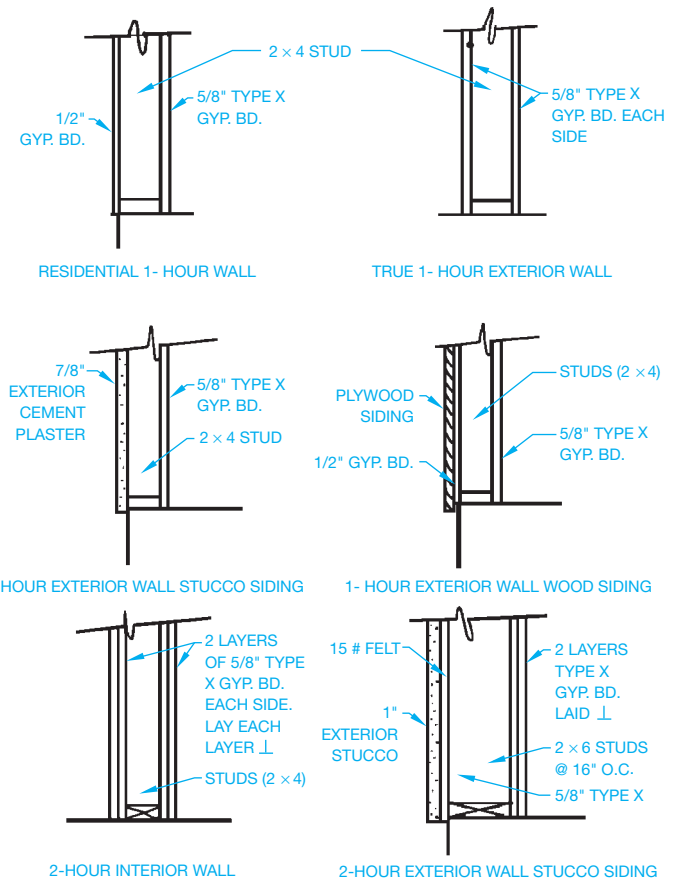


FIGURE 22.32 Separation walls often require special treatment to achieve the needed fire rating for certain types of construction. © Cengage Learning 2012

beams are required, the solution is **laminated (lam) beams** as shown in Figure 22.37. Notice the beams labeled GLB 1, GLB 2, GLB 3, and GLB 4 in Figure 22.33. These are **glulam beams (GLB)**. The intermediate members labeled P1 and P2 are purlins, as previously discussed. Laminated beams are manufactured from smaller, equally sized members glued together to form a larger beam. Laminated beams are used to support heavy loads or accommodate long spans and are also used when the wood appearance is important. The common types of laminated beams are the **single span straight**, **Tudor arch**, and **three-hinged arch beams** (see Figure 22.38).

The single span beam is commonly referred to as glulam and noted on a drawing with the abbreviation GLB for glulam beam. A glulam beam can be used to replace a much larger wood timber because of increased structural qualities. Figure 22.39 compares the strength of common wood members with laminated beams. In some applications, laminated beams have a **camber** or curve built into the beam. The camber is designed into the beam to help resist the loads to be carried.

The Tudor and three-hinged arch members are a post-and-beam system combined into one member. These beams

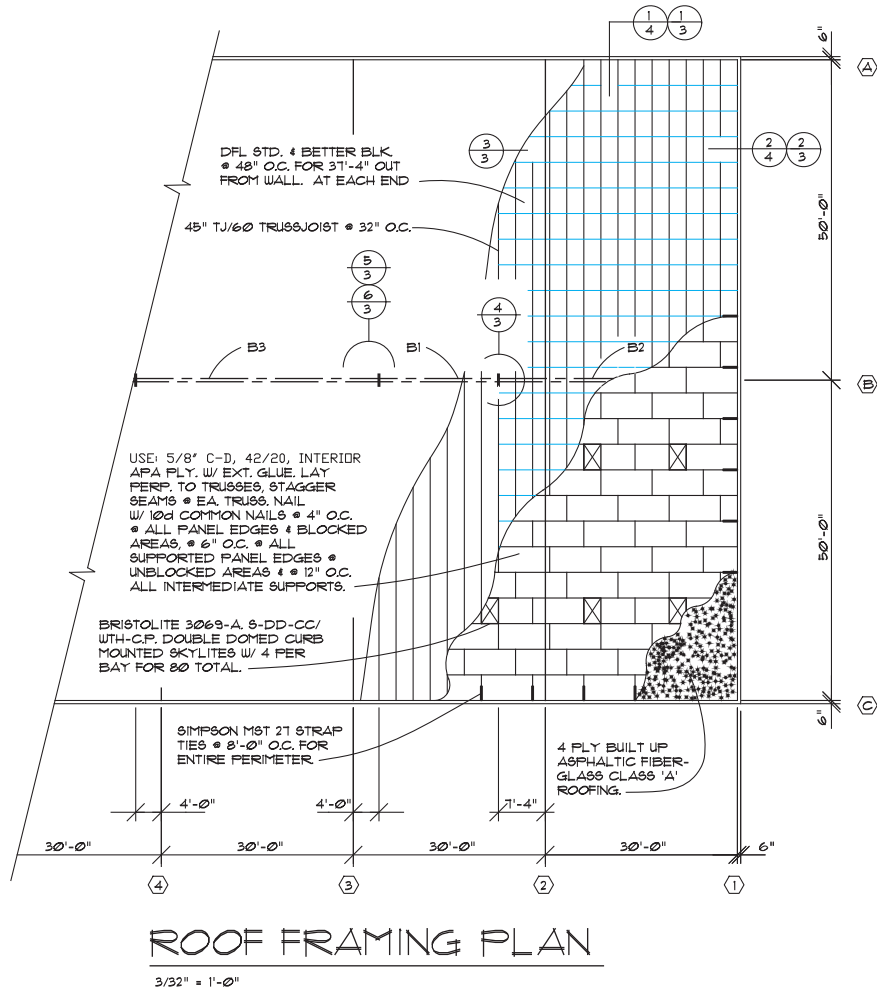
are specified on plans in a method similar to other beams. The drafter's major responsibility when working with either heavy timber construction or laminated beams is in the drawing of connection details. Beam to beam, beam to column, and column to support are among the most common details drawn by drafters. Common types of manufactured connectors used to connect timbers are shown in Figure 22.40 on page 958. The drafter is required to draw the fabrication details for a connector when the size of the beam does not match existing connectors as shown in Figure 22.41 on page 958.

Wood members can be attached to concrete in several ways. Two of the most common methods are by the use of a pocket or seat as shown in Figure 22.42 on page 959 or by a metal connector.

### Engineered Wood Products

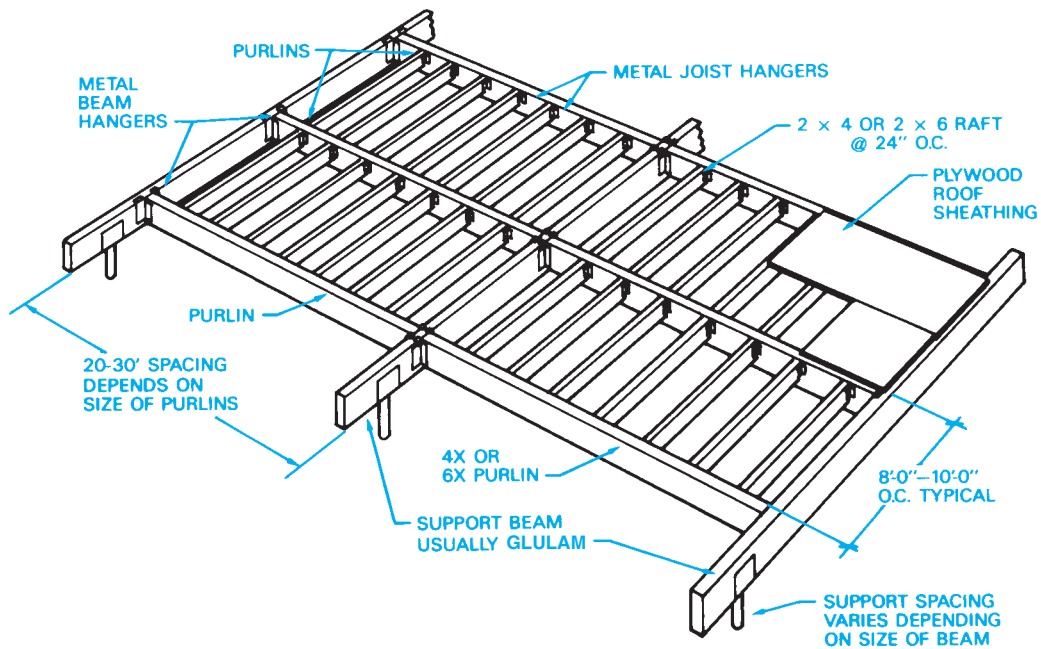
**Engineered wood products** are a variety of products that have been designed to replace conventional lumber and provide many advantages, such as reducing the industry dependence on





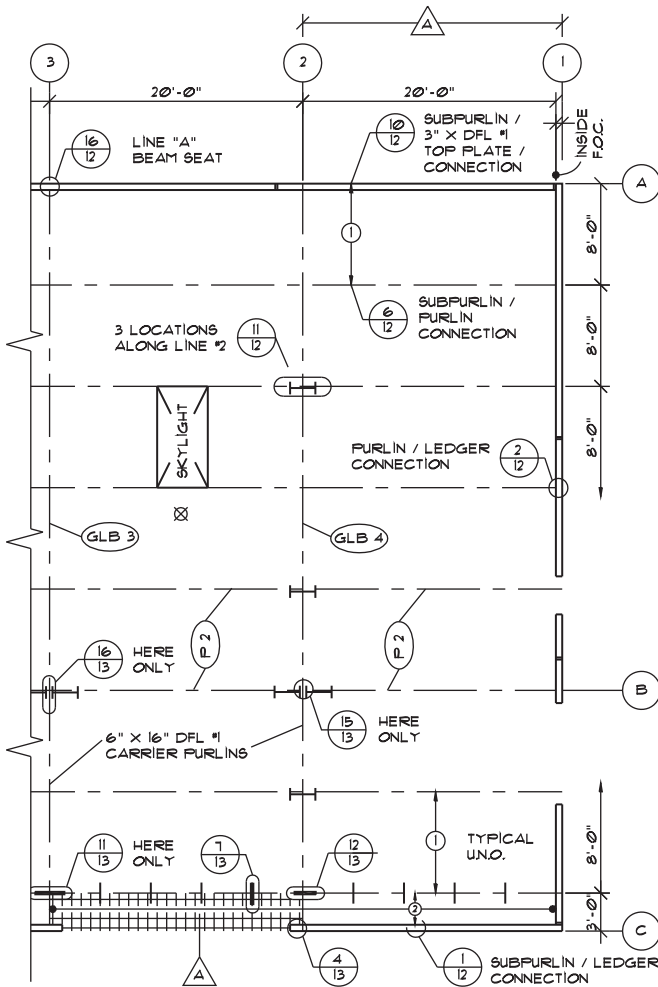
© Cengage Learning 2012

FIGURE 22.33 A truss roof framing plan.



© Cengage Learning 2012

FIGURE 22.34 A panelized roof system is often used to provide roofing for large area with limited supports.



Courtesy: Structureform Masters, Inc.

**FIGURE 22.35** A panelized roof and heavy timber framing plan.

natural lumber. Common types of engineered wood products include I-joists, laminated veneer lumber, and related products such as rim board.

### I-Joists

**I-joists** are generally made of softwood veneers such as fir or pine that are bonded together or solid wood to make the top and bottom flanges. The web or core is then made of composite wood. The name comes from the I shape that is shown in Figure 22.43 on page 959.

I-joists provide stronger and more stable performance; are lighter weight, easier to handle, and faster to install; and they make more efficient use of valuable wood resources than conventional lumber. They also provide longer lengths and prestamped knockouts for wire or plumbing runs. I-joists are drawn just like other joists in the plan view using solid lines or centerlines. The shape of the I-joist showing the top and bottom flanges and the core is displayed when drawing in sectional view.

## Laminated Veneer Lumber

**Laminated veneer lumber (LVL)** is an engineered structural member that is manufactured by bonding wood veneers with an exterior adhesive. LVL has almost no shrinking, checking, twisting, or splitting; it is excellent for floor and roof framing supports or as **headers** for doors, windows, and garage doors and columns. LVL has no camber, so LVL products provide flatter, quieter floors. Headers are horizontal structural members provided over an opening to support the load above. Headers can also be used at the end of joists to tie the joists together around an opening.

LVL is available in lengths that are longer than conventional lumber, so builders can avoid on-site splicing and multiple nailing and save on labor costs. Common sizes range from 1-3/4" to 7" (40–180 mm) wide, with depths from 5 1/2" to 18" (140–460 mm), and lengths of up to 66' (20 mm). Figure 22.44 shows an example of LVL sizes. Figure 22.45 shows a comparison of physical properties of glulam lumber, laminated veneer lumber, and solid lumber. You can see the physical advantage of the LVL product. The physical properties vary, depending on the type of material and the manufacturer. LVL members are drawn like other beams, using a thick solid line or a thick centerline symbol. The dimensional values given in this discussion are examples. Actual dimensions must be determined by structural engineering based on the building design.

### Rim Board

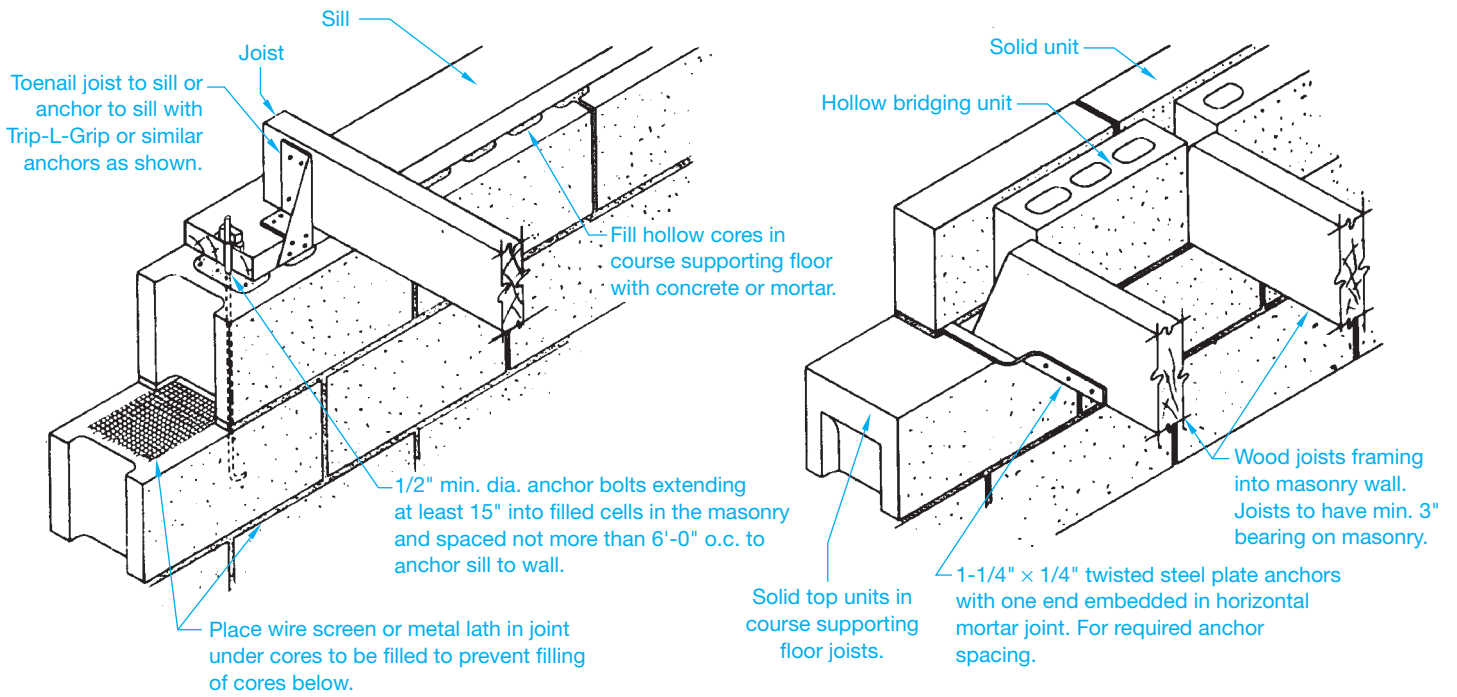
As part of a complete engineered wood construction system, the **rim board** is used to cap the ends of the I-joist construction just like the rim joist used in conventional framing systems. The advantages of engineered rim joists are that they exactly match I-joist depths, require no special backing for siding products, and are quick and easy to install. Rim boards have almost no shrinking, checking, twisting, or splitting. Rim boards cannot be used as headers or beams.

### Plywood Lumber Beams

**Plywood lumber beams** are also an engineered wood product that are made to precise specifications in size and nailing requirements for specific applications. Plywood lumber beams are also known as **box beams**. You can see their boxlike construction in Figure 22.46.

### Stressed Skin Panels

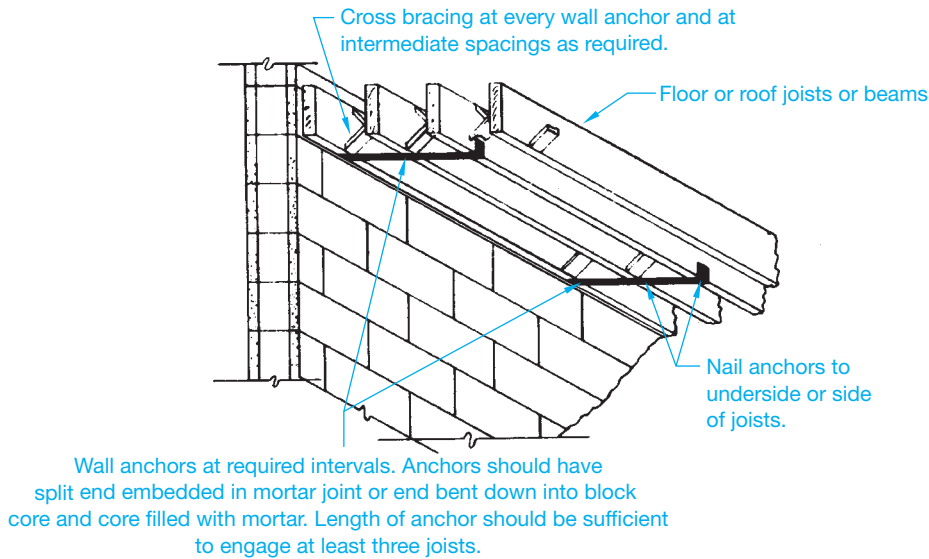
**Stressed skin panels** use solid lumber or engineered lumber stringers and headers with a plywood skin on the top and bottom as shown in Figure 22.47. These panels can be used for walls, floors, and roof systems. They allow the builder to quickly erect a building because they cover a large area. They are commonly used in remote areas where they can be shipped in and quickly installed.



ANCHORAGE OF WOOD JOISTS TO FOUNDATION IN WOOD FRAME CONSTRUCTION

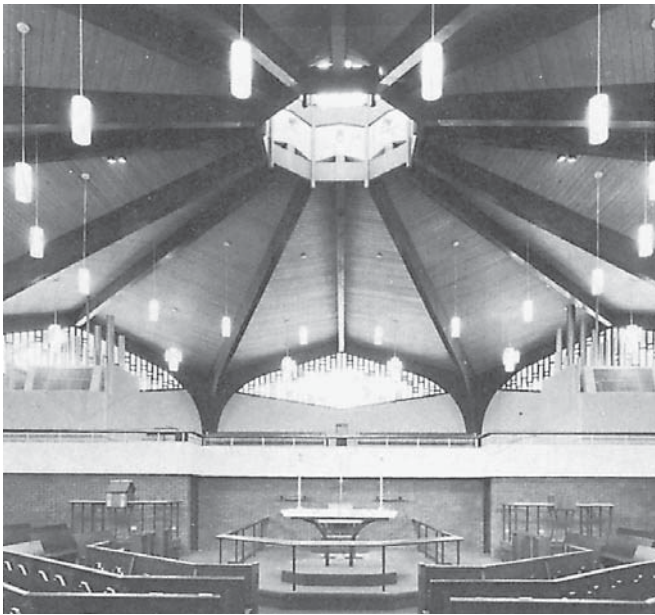
ANCHORAGE OF WOOD JOISTS TO FOUNDATION IN MASONRY CONSTRUCTION

**SUGGESTED METHODS OF ANCHORING WOOD JOISTS BEARING ON CONCRETE MASONRY FOUNDATION WALLS.**



**TYPICAL DETAILS FOR ANCHORAGE OF CONCRETE MASONRY WALLS TO PARALLEL WOOD JOISTS OR BEAMS.**

**FIGURE 22.36** Metal angles and straps are typically used to ensure a rigid connection between the wall and floor or roof system. *Courtesy National Concrete Masonry Association*



**FIGURE 22.37** Timbers are often used in commercial construction because of their beauty and structural qualities. The structural system of St. Philip's Episcopal Church is formed by flue-laminated Southern pine arches and beams under a sweeping canopy of Southern pine roof decking. *Courtesy Southern Forest Products Association*

### Standard Wood Structural Callouts

When specifying the callouts for structural wood sizes on a drawing, give the **nominal** (rough, before planning) cross-sectional dimensions for sawn lumber and timbers. For example,

$$4 \times 12, 6 \times 14$$

The nominal size of a wood construction member is before milling. The actual finished size is different. For example, the nominal size before milling is provided in the previous drawing specification. The milling process makes the finished member  $3\text{-}1/2" \times 11\text{-}1/2"$  and  $5\text{-}1/2" \times 13\text{-}1/2"$ , respectively. Metric values for lumber are specified in millimeters and are rounded to common metric standards. For example, a  $4" \times 12"$  wood member is specified as  $100 \times 300$  mm.

The **net** (actual) cross-sectional dimension is given for glulams. The net dimensions of a glulam are followed by the abbreviation GLB and engineering specification. For example,

$$6\text{-}1/8 \times 14 \text{ GLB f2400f2400}$$

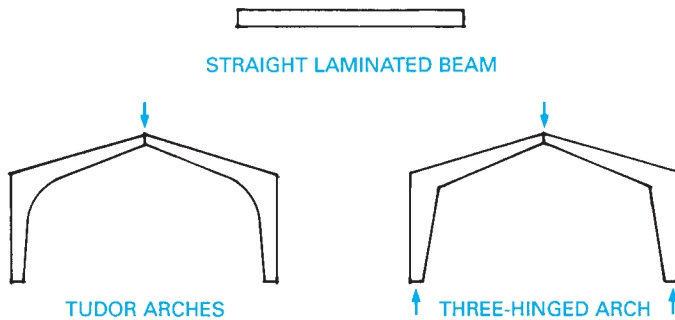
is the engineering specification designating the actual units of stress in fiber bending.

If the net cross-sectional dimensions for lumber are required, they can be given in parentheses after the nominal dimensions. If lengths (LG) are required for wood members, they should be given in feet and inches or millimeters. For example,

$$6\text{-}3/4 \times 18 \text{ GLB} \times 24\text{'-}0" \text{ LG}$$

Glulam beams can also be designated with a manufacturing number such as

$$6\text{-}3/4 \times 18 \text{ 22FV4}$$



**FIGURE 22.38** Common laminated beam shapes. © Cengage Learning 2012

Commercial Grade	Extreme Fiber Bending $F_b$	Horizontal Shear $F_v$	Compression Perpendicular to Grain $F_c \perp$	Modulus of Elasticity E
DFL #1	1350	85	385	1,600,600
22FV4	2200	165	385	1,700,000
DF/DF				
Hem-Fir #1	1050	70	245	1,300,000
22F E2	2200	155	245	1,400,000
HF/HF				
SPF	900	65	265	1,300,000
22F-E-1	2200	200	385	1,400,000
SP/SP				

**FIGURE 22.39** Comparative values of common framing lumber with laminated beams of equal material. Values based on the Uniform Building Code. © Cengage Learning 2012

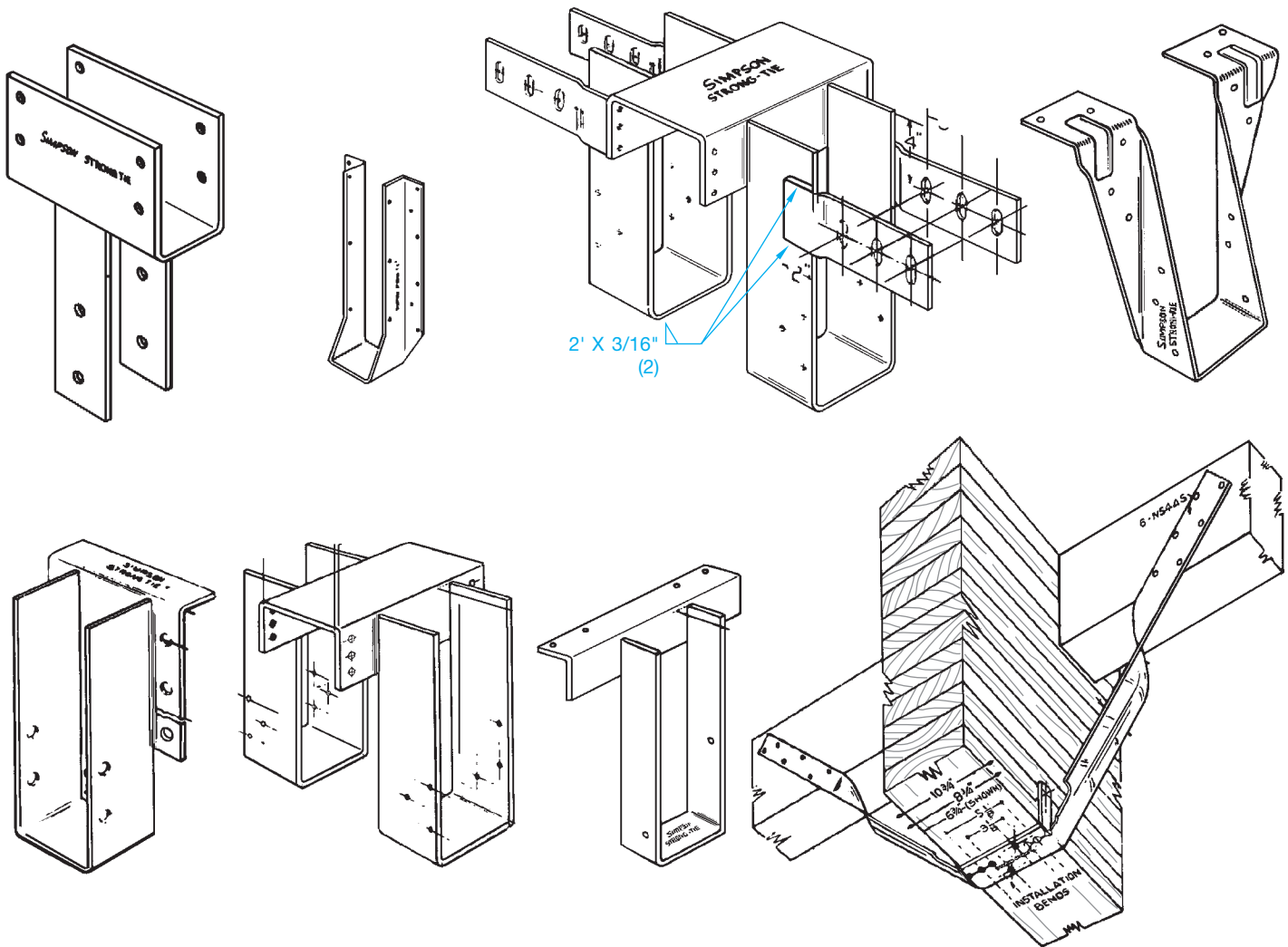


FIGURE 22.40 Common manufactured metal beam connectors. Courtesy Simpson Strong-Tie Company, Inc.

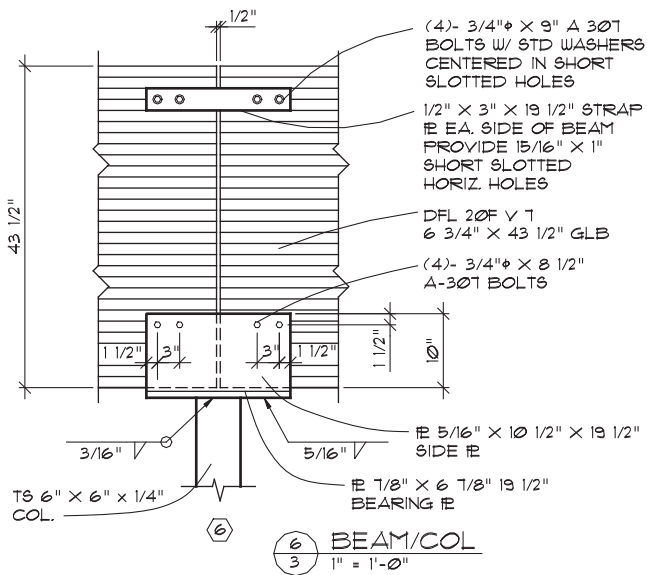


FIGURE 22.41 Fabrication details for a connector when the size of the beam does not match existing connectors.

The 6-3/4 × 18 gives the width and depth, and the 22FV4 designation represents the following values:

- 22F This is the fiber bending,  $f$  or  $F_b$  as given in previous examples. Different wood species have different fiber-bending values.
- V4 This is a designation that varies, depending on the wood species and the application for the beam. This specification might be V1, V2, V3, or E1, E2, E3, for example. The options include the species of laminations outside and inside of the beam. This also relates to the application for the beam, such as downloading, uploading, and cantilever.

**Downloading** refers to a beam that is designed to support weight from above. **Uploading** refers to a beam that can accept forces that push up on the beam, such as wind loads or the forces of weight applied to an adjacent cantilever. Some beams are designed to accept both downloading and uploading. **Cantilever** beams are designed to project beyond their supporting wall or column. Refer to building codes for glulam beams or manufacturers' catalogs for specific information about these glulam beam designations.

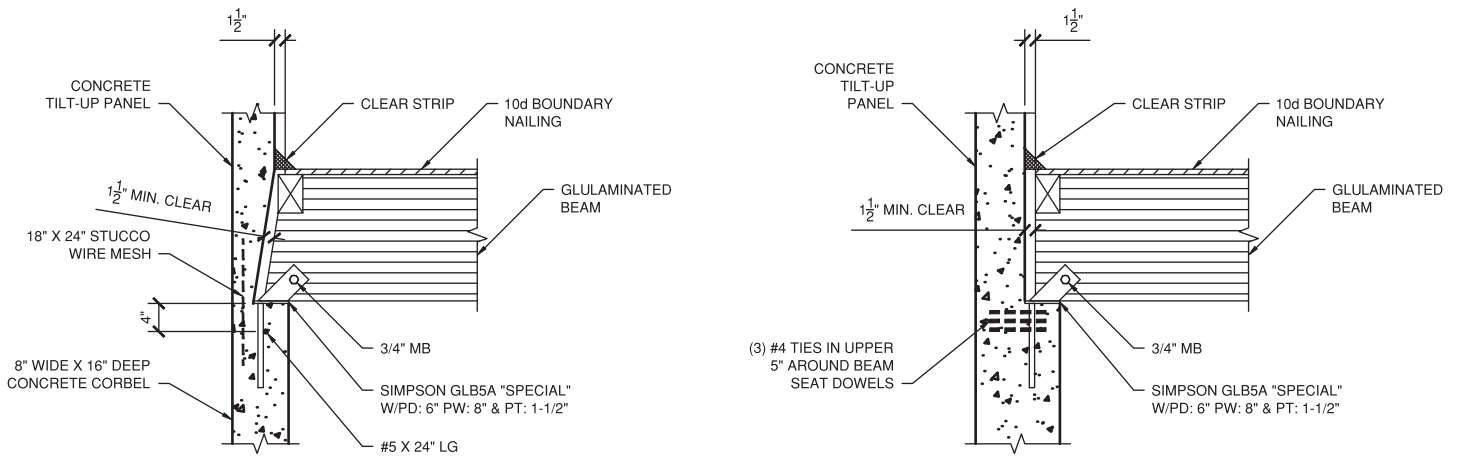


FIGURE 22.42 Wood beams are often designed to rest on a ledge or pocket. Courtesy Structureform Masters, Inc.

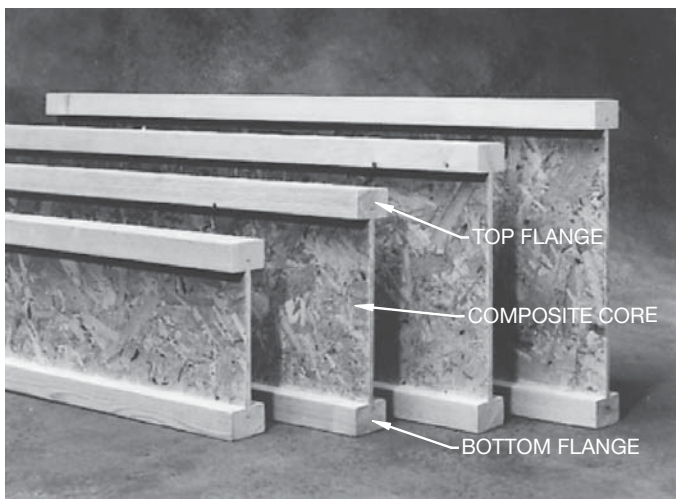


FIGURE 22.43 The I-joist has top and bottom flanges connected by a composite wood core. Courtesy Louisiana-Pacific Corporation

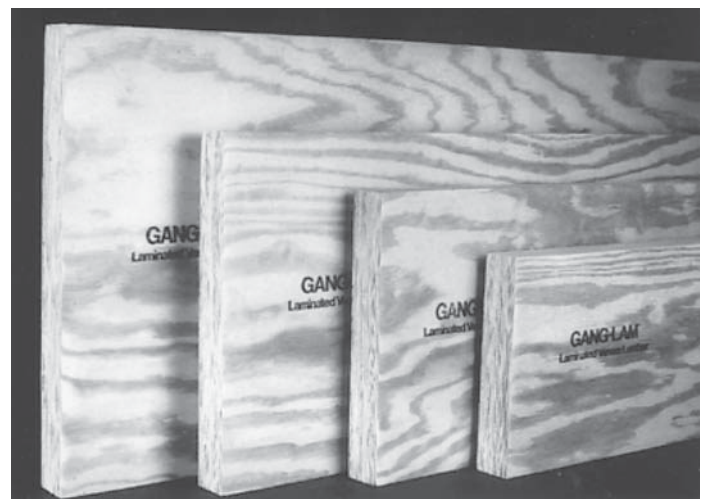


FIGURE 22.44 Laminated veneer lumber (LVL) is manufactured by bonding layers of wood veneer with an exterior adhesive. Courtesy Louisiana-Pacific Corporation

Property	LVL <sup>a</sup>	Glued Laminated <sup>b</sup>	Solid Lumber <sup>c</sup>
Extreme fiber in bending ( $F_b$ ) psi	3000	1600–2400	760–2710
Horizontal shear ( $H_v$ ) psi	290	140–650	95–120
Compression perpendicular to grain ( $F_{c\perp}$ ) psi	3180	375–650	565–660
Compression parallel with grain ( $F_c$ ) psi	—	1350–2300	625–1100
Tension parallel with grain ( $F_t$ ) psi	2300	1050–1450	450–1200
Modulus of elasticity (E) million psi	2.0	1.2–1.8	1.3–1.9

<sup>a</sup>Limited to one size member

<sup>b</sup>Data from one manufacturer

<sup>c</sup>Data for one species of lumber

FIGURE 22.45 Properties of laminated veneer lumber, glulam members, and solid lumber. © Cengage Learning 2012

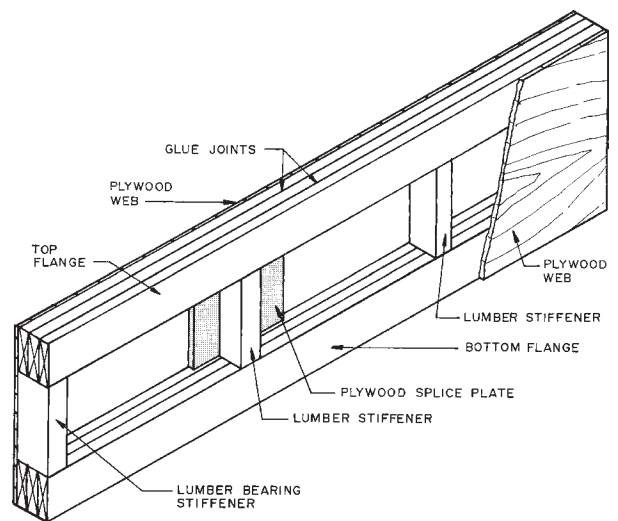


FIGURE 22.46 A typical plywood lumber beam (box beam) with plywood webs and solid wood flanges and stiffeners.

© Cengage Learning 2012

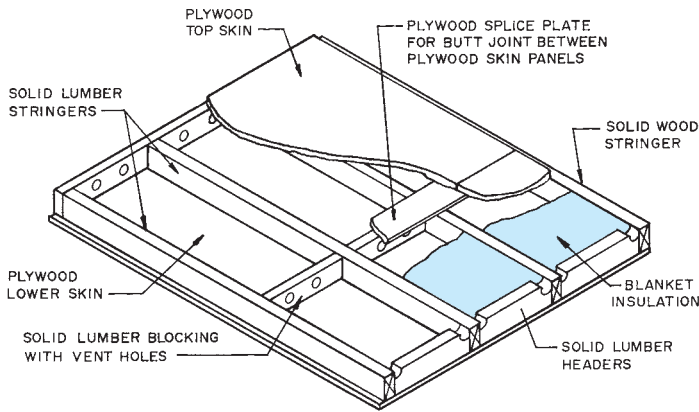


FIGURE 22.47 A stress skin panel. © Cengage Learning 2012

The specifications for laminated veneer lumber vary slightly between manufacturers, but the elements of the note are similar. For example, an LVL beam or header might be specified like this:

1 3/4" × 14" BCI VERSALAM – D

The 1- 3/4" × 14" is the width and depth, and the other elements are described as follows:

- BCI This is the manufacturer—in this case, Boise Cascade Corporation.
- VERSALAM This is a specific LVL product of the Boise Cascade Corporation called Versa-Lam®.
- D This identifies the wood species—Douglas fir in this case.

The specifications for I-joists can also vary between manufacturers, but there are similar components, such as

14" BCI 90XL @ 16" OC

The following identifies each of the elements of this I-joist note:

- 14" This is the depth of the I-joist.
- BCI This is the manufacturer—in this case, Boise Cascade Corporation.
- 90XL This identifies the strength characteristics based on a specific BCI I-joist.
- @16" OC This is the spacing on center of the I-joists.

When wood is used for floor joists (FJ) or ceiling joists (CJ), rafters or trusses, or stud walls, the member size is followed by the OC spacing in inches up to 24" (600 mm) OC and feet and inches for over 24" OC. For example, abbreviations are shown in parentheses:

- 2 × 8 CEILING JOISTS (CJ) 16" OC
- 4 × 14 @ 4'-0" OC
- 2 × 6 STUDS 24" OC
- 2 × 12 FLOOR JOISTS (FJ) 12" OC

All lumber and timber on a drawing should be dimensioned to the centerlines unless dimensioning to the face of the member is otherwise required by the engineer or architect. The exception to this rule is dimensioning to the top of a beam or other structural timber.

When specifying plywood on a drawing, give the thickness, group, face veneer grades, identification index (if required), and glue type for each different panel used. Also include nailing, blocking, and edge spacing requirements if specific applications are required. Dimension to the face of the panel when surface location dimensions are required. **Plywood** is wood composed of three or more layers of thin veneer sheets, with the grain of each sheet placed at 90° to each other and bonded together with glue. Plywood sheets are typically 4' × 8' (1200 × 2400 mm) and come in a variety of thicknesses for different structural applications. The following are plywood callout examples:

1. 1/2" CDX 32/16 PLYWOOD SHEATHING.
2. 1/2" CDX SHTG W/10d NAILS 3" OC @ SEAMS AND 8" OC FIELD. SEAMS are edges or splices, and FIELD is the area within the sheet at supports.
3. 1/2" GROUP 1, CC, 24/0 EXTERIOR APA PLYWOOD W/8d NAILS 4" OC @ EDGES AND @ 6" OC FIELD.
4. 5/8" GROUP 2, UNDERLAYMENT CC-PTS EXTERIOR APA PLYWOOD W/8d RING SHANK NAILS @ 3" OC EDGES AND 6" OC FIELD, BLOCK ALL PANEL EDGES PERPENDICULAR TO SUPPORTS.

CC means CC grade outside veneer, PTS means plugged and touch sanded.

When lumber decking is used, the lumber size and specification is followed by nailing information, if required. For example,

3 × 8 T&G RANDOM CONTROLLED DECKING W/20d TOE-NAIL EACH SUPPORT AND 30d RING SHANK FACE NAIL EACH SUPPORT

**Random controlled** means various lengths, usually 4'-0" modules placed so there are not two adjacent splices in the same support. **T&G** refers to **tongue and groove**.

## STEEL CONSTRUCTION

Steel construction can be divided into three categories: steel studs, prefabricated steel structures, and steel-framed structures.

### Steel Studs

Prefabricated **steel studs** are used in many types of commercial structures. Steel studs offer lightweight, noncombustible, corrosion-resistant framing for interior partitions and load-bearing exterior walls as high as four stories. Steel members are available for use as studs or joists. Members are designed

for rapid assembly and are predrilled for electrical and plumbing conduits. The standard 24" (600 mm) spacing reduces the number of studs required by about one-third when compared with wood studs spaced 16" (400 mm) OC. Steel stud widths range from 3-5/8" to 10" (90–250 mm) but can be manufactured in any width. The material used to make studs ranges from 12- to 20-gage steel, depending on the design loads to be supported. Steel studs are mounted in a channel track at the top and bottom of the wall or partition. This channel serves to tie the studs together at the ends. Horizontal bridging is often placed through the predrilled holes in the studs and then

welded to the studs to serve as fire blocking within walls and as mid supports. The components of steel stud construction are shown in Figure 22.48.

### Prefabricated Steel Structures

Prefabricated or metal buildings, as they are often called, have become a common type of construction for commercial and agricultural structures in many parts of the country. Drafters who are involved in the preparation of drawings for

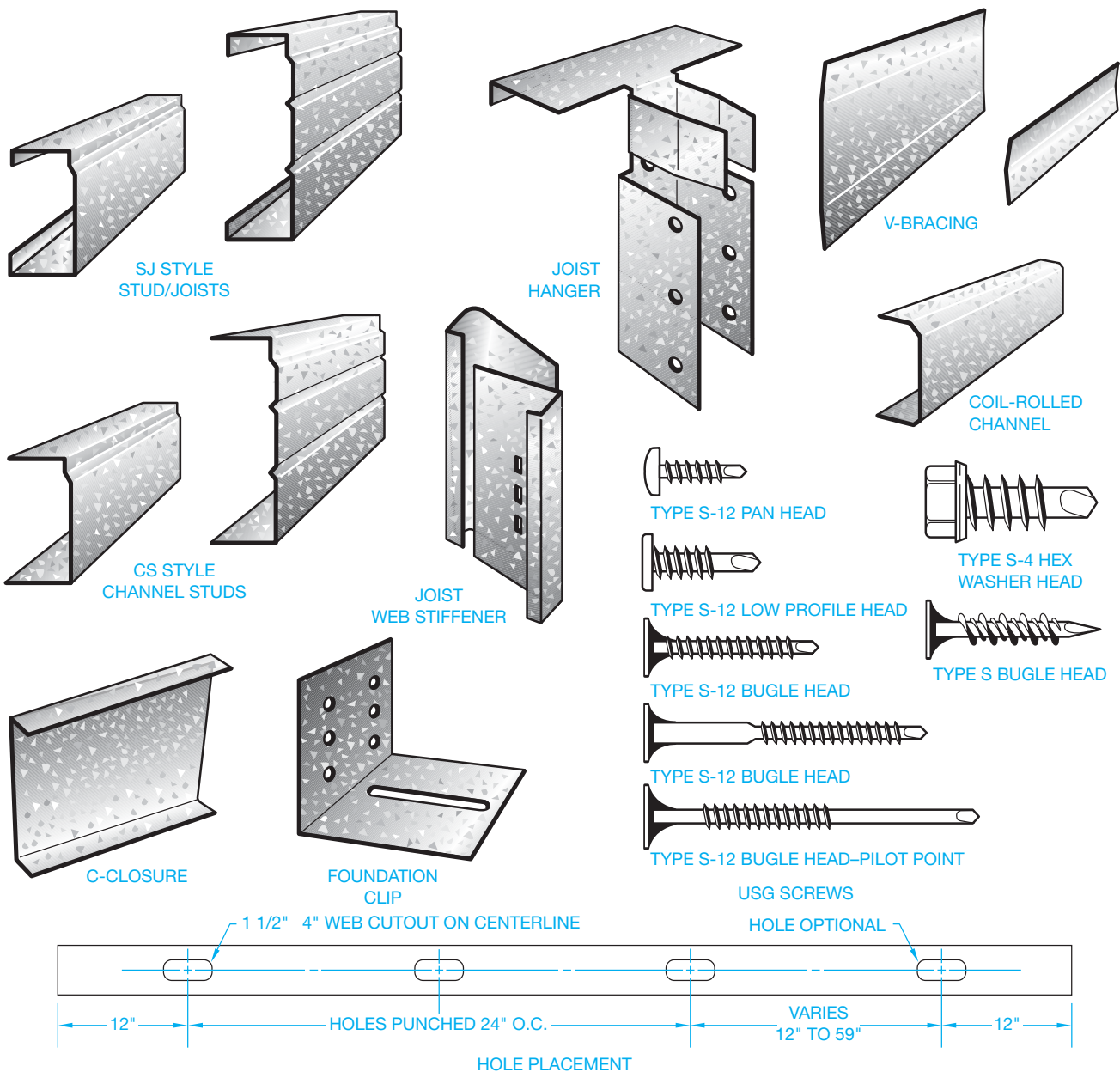


FIGURE 22.48 Common components of steel stud construction.

Courtesy United States Gypsum Company



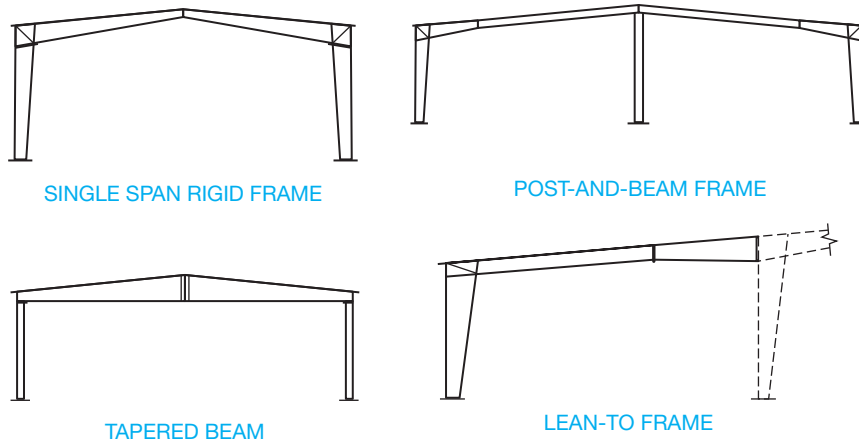


FIGURE 22.49 Common prefabricated structural systems.

© Cengage Learning 2012

premanufactured structures may work in a structural engineering office or for a building manufacturer. Standardized premanufactured steel buildings are often sold as modular units with given spans, wall heights, and lengths in 12' or 20' (3600–6000 mm) increments. Most manufacturers provide a wide variety of design options for custom applications that may be required by the client. One advantage of these structures is faster erection time as compared with other construction methods.

### The Prefabricate Steel Structural System

The prefabricate steel structural system is made up of the **frame** that supports the walls and roof. There are several different types of structural systems commonly used, as shown in Figure 22.49. The wall system is horizontal **girts** attached to the vertical structure and metal wall sheets attached to the girts. Girts are attached horizontally to the vertical wall structure and used to attach the metal siding in steel construction. The roof system is horizontal **purlins** attached to the structure and metal sheets attached to the purlins (see Figure 22.50). Purlins are attached horizontally to the roof framing system and are used to attach the metal sheets of roofing material in steel construction. Steel wall and roof sheets are available from many vendors in a variety of patterns and can be purchased plain, galvanized, or prepainted. A sample pattern design is shown in Figure 22.51.

### Steel-Framed Structures

Steel-framed buildings require structural engineering and shop drawings. As a drafter in an engineering or architectural firm, you may be drafting engineering drawings similar to the one shown in Figure 22.52.

### STANDARDS

**AISC** Drafters in the steel construction field must become familiar with the *Manual of Steel Construction* published by the American Institute of Steel Construction, Inc. (AISC). The *Manual of Steel Construction* is a primary reference that helps you determine dimensions and properties of common steel shapes. The manual also provides local and national building codes.

**USS** Another manual that provides information on dimensions for detailing and properties for design work related to steel structural materials is *Structural Steel Shapes*, published by the U.S. Steel Corporation (USS) ([www.uss.com](http://www.uss.com)).

### Common Structural Steel Materials

Structural steels are commonly identified as plates, bars, or shape configurations. **Plates** are flat pieces of steel of various thickness used at the intersection of different members and for

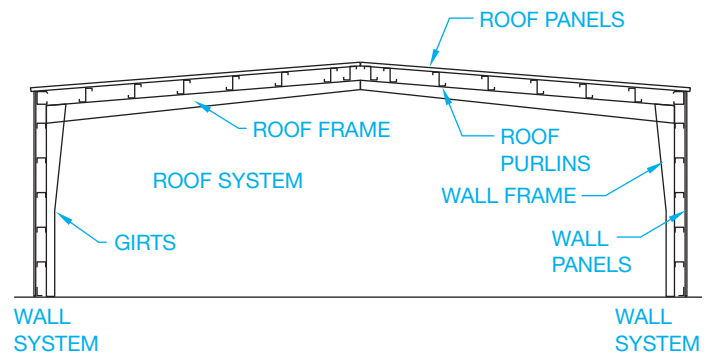
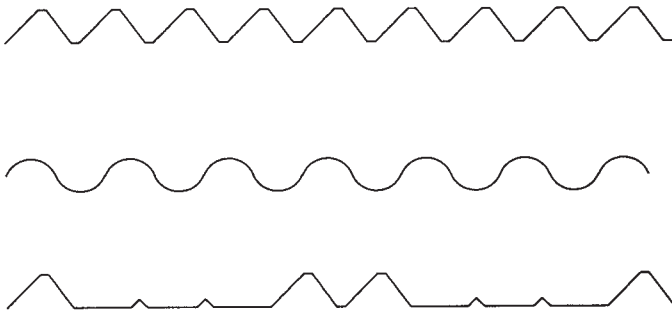


FIGURE 22.50 Components of the prefabricated structural system. © Cengage Learning 2012



**FIGURE 22.51** Typical cross sections of sheet metal siding and roofing material; many pattern shapes and finish colors are available. © Cengage Learning 2012

the fabrication of custom connectors. Figure 22.53 shows an example of a steel connector that uses top, side, and bottom plates. Plates are typically specified on a drawing by giving the thickness, width, and length in that order and with or without inch marks. The symbol  $\text{P}$  is often used to specify plate material. For example,

$$\text{P}1/4 \times 6 \times 10$$

**Bars** are the smallest of structural steel products and are manufactured in round, square, rectangular, flat, or hexagonal cross sections. Bars are often used as supports or braces for other steel parts or connectors. Flat bars are usually specified on a drawing by giving the width, thickness, and length, in that order. For example,

$$\text{BAR } 3 \times 1/2 \times 1'-6"$$

Structural steel is also available in several different manufactured shapes as shown in Figure 22.54. When specifying a steel shape on a drawing, the shape identification letter is followed by the member depth, the by symbol ( $\times$ ), and the weight in number of pounds per linear foot. For example,

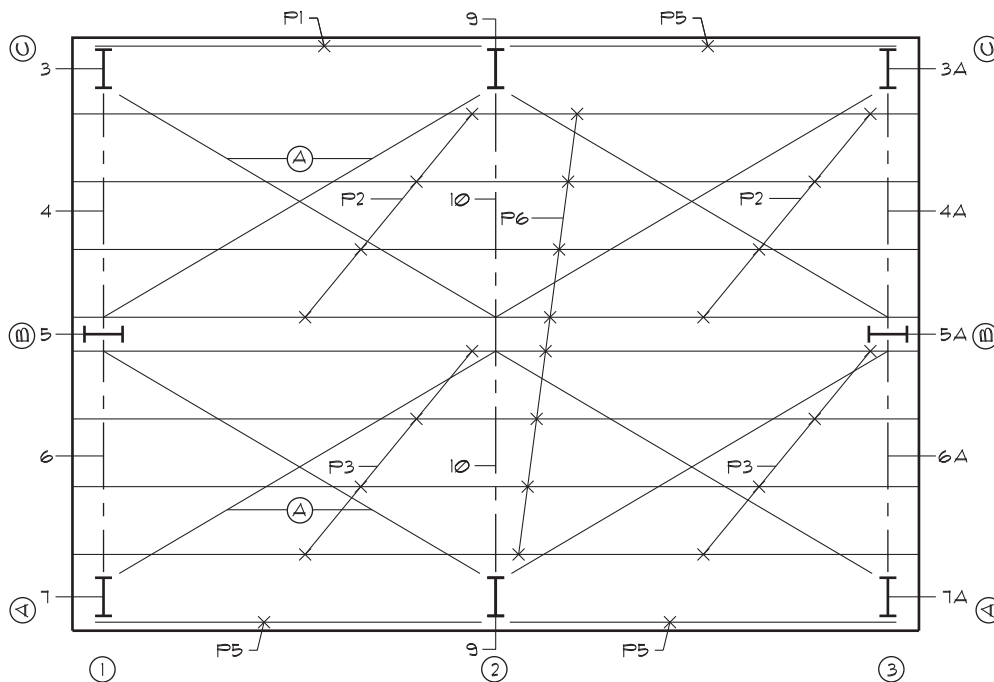
$$\text{W } 12 \times 22 \text{ or C } 6 \times 10.5$$

as shown in Figure 22.55. In the *AISC Manual of Steel Construction*, specific information regarding dimensions for detailing and dimensioning is clearly provided along with typical connection details. The representative pages for the W 12  $\times$  22 wide flange and the C 6  $\times$  10.5 channel from Figure 22.55 are shown in Figure 22.56. The W, S, and M shapes all have an I-shaped cross section and are often referred to as I beams. The three shapes differ in the width of their flanges. In addition to varied flange widths, the S-shape flanges are tapered, making them stronger than equivalently sized W beams and suitable for train rail or monorail beams. The W shape is commonly used for columns. All can be used for horizontal or vertical members.

**Angles** are structural steel components that have an L shape. The legs of the angle can be either equal or unequal in length but are usually equal in thickness. Channels have a squared C cross-sectional area and are designated with the letters C or MC.

**Structural tees** are produced from W, S, and M steel shapes. Common designations include WT, ST, and MT.

**Structural tubing** is manufactured in square, rectangular, and round cross-sectional configurations. These members are



**FIGURE 22.52** Structural steel engineering drawing.

Courtesy Pacific Building Systems

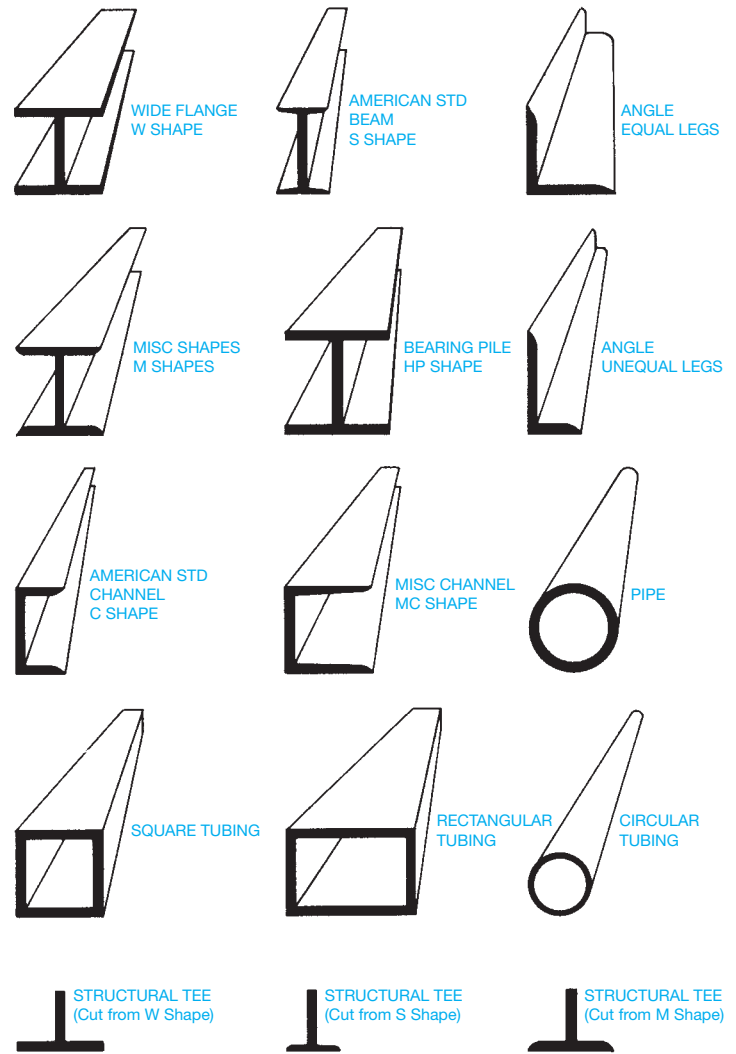
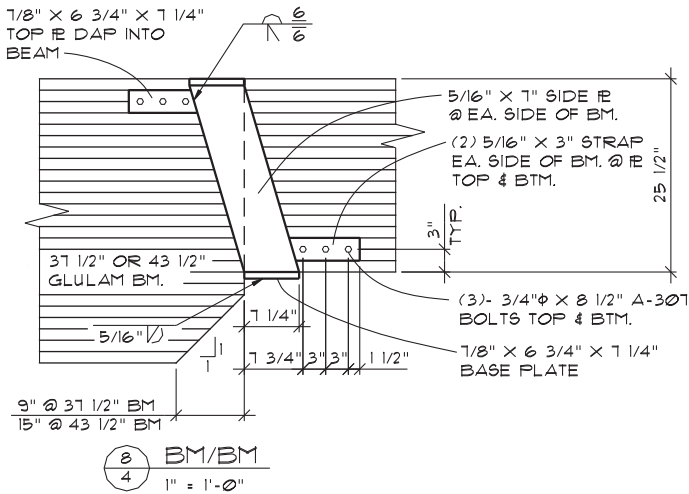


FIGURE 22.53 Steel plates used to fabricate a beam connector. © Cengage Learning 2012

used as columns to support loads from other members. Tubes are also commonly used for beams and truss members. Tubes are specified by the size of the outer wall followed by the thickness of the wall.

**Steel pipe** is also commonly used for columns and bracing. Available steel pipe strengths are standard, extra strong, and double-extra strong. The wall thickness increases with each type.

A variety of templates are available for structural drafting to assist in drawing steel shapes. Many CADD programs are available also to increase structural drafting productivity.

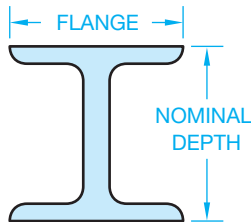
FIGURE 22.54 Standard structural steel shapes. © Cengage Learning 2012

### Structural Steel Callouts

Many structural steel materials are specified by shape designation, flange width, and weight in pounds per linear foot. For example,

W 24 × 120

#### WIDE FLANGE SHAPES

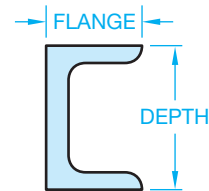


THE DESIGNATION FOR A WIDE FLANGE LOOKS LIKE THIS:

**W 12 22**

WHERE: **W** IS THE SHAPE  
**12** IS THE NOMINAL DEPTH  
**22** IS THE NUMBER OF POUNDS PER LINEAL FOOT

#### CHANNELS

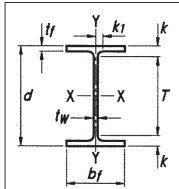


THE DESIGNATION FOR A CHANNEL SHAPE LOOKS LIKE THIS:

**C 6 10.5**

WHERE: **C** IS THE SHAPE  
**6** IS THE DEPTH  
**10.5** IS THE NUMBER OF POUNDS PER LINEAL FOOT

FIGURE 22.55 Dimensional elements of the wide flange and channel shapes.

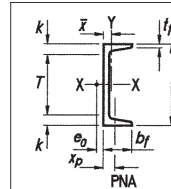


**Table 1-1 (continued)  
W Shapes  
Dimensions**

Shape	Area, A		Depth, d	Web			Flange			Distance					
	in. <sup>2</sup>			Thickness, tw	tw/2	Width, bf	Thickness, tf	k		k1	T	Workable Gage			
	in.	in.						in.	in.				in.	in.	
W12x58	17.0	12.2	12 1/4	0.360	3/8	3/16	10.0	10	0.640	5/8	1.24	1 1/2	1 1/2	9/4	5 1/2
×53	15.6	12.1	12	0.345	3/8	3/16	10.0	10	0.575	9/16	1.18	1 3/8	1 1/2	9/4	5 1/2
W12x50	14.6	12.2	12 1/4	0.370	3/8	3/16	8.08	8 1/8	0.640	5/8	1.14	1 1/2	1 1/2	9/4	5 1/2
×45	13.1	12.1	12	0.335	5/16	3/16	8.05	8	0.575	9/16	1.08	1 3/8	1 1/2	9/4	5 1/2
×40	11.7	11.9	12	0.295	5/16	3/16	8.01	8	0.515	1/2	1.02	1 3/8	7/8	9/4	5 1/2
W12x35 <sup>c</sup>	10.3	12.5	12 1/2	0.300	5/16	3/16	6.56	6 1/2	0.520	1/2	0.820	1 3/16	3/4	10 1/8	3 1/2
×30 <sup>c</sup>	8.79	12.3	12 3/8	0.260	1/4	1/8	6.52	6 1/2	0.440	7/16	0.740	1 1/8	3/4	9/4	3 1/2
×26 <sup>c</sup>	7.65	12.2	12 1/4	0.230	1/4	1/8	6.49	6 1/2	0.380	3/8	0.680	1 1/16	3/4	9/4	3 1/2
W12x22 <sup>c</sup>	6.48	12.3	12 1/4	0.260	1/4	1/8	4.03	4	0.425	7/16	0.725	1 5/16	5/8	10 3/8	2 1/4 <sup>g</sup>
×19 <sup>c</sup>	5.57	12.2	12 1/8	0.235	1/4	1/8	4.01	4	0.350	3/8	0.650	7/8	9/16	9/4	2 1/4 <sup>g</sup>
×16 <sup>c</sup>	4.71	12.0	12	0.220	1/4	1/8	3.99	4	0.265	1/4	0.565	1 13/16	9/16	9/4	2 1/4 <sup>g</sup>
×14 <sup>c,v</sup>	4.16	11.9	11 7/8	0.200	3/16	1/8	3.97	4	0.225	1/4	0.525	3/4	9/16	9/4	2 1/4 <sup>g</sup>
W10x112	32.9	11.4	11 3/8	0.755	3/4	3/8	10.4	10 3/8	1.25	1 1/4	1.75	1 5/16	1	7 1/2	5 1/2
×100	29.4	11.1	11 1/8	0.680	11/16	3/8	10.3	10 3/8	1.12	1 1/8	1.62	1 13/16	1	7 1/2	5 1/2
×88	25.9	10.8	10 7/8	0.605	5/8	5/16	10.3	10 1/4	0.990	1	1.49	1 11/16	1 5/16	7 1/2	5 1/2
×77	22.6	10.6	10 5/8	0.530	1/2	1/4	10.2	10 1/4	0.870	7/8	1.37	1 9/16	7/8	7 1/2	5 1/2
×68	20.0	10.4	10 3/8	0.470	1/2	1/4	10.1	10 1/8	0.770	3/4	1.27	1 7/16	7/8	7 1/2	5 1/2
×60	17.6	10.2	10 1/4	0.420	7/16	1/4	10.1	10 1/8	0.680	11/16	1.18	1 3/8	1 3/16	7 1/2	5 1/2
×54	15.8	10.1	10 1/8	0.370	3/8	3/16	10.0	10	0.615	5/8	1.12	1 5/16	1 3/16	7 1/2	5 1/2
×49	14.4	10.0	10	0.340	5/16	3/16	10.0	10	0.560	9/16	1.06	1 1/4	1 3/16	7 1/2	5 1/2
W10x45	13.3	10.1	10 1/8	0.350	3/8	3/16	8.02	8	0.620	5/8	1.12	1 5/16	1 3/16	7 1/2	5 1/2
×39	11.5	9.92	9 7/8	0.315	5/16	3/16	7.99	8	0.530	1/2	1.03	1 3/16	1 3/16	7 1/2	5 1/2
×33	9.71	9.73	9 3/4	0.290	5/16	3/16	7.96	8	0.435	7/16	0.935	1 1/8	3/4	7 1/2	5 1/2
W10x30	8.84	10.5	10 1/2	0.300	5/16	3/16	5.81	5 3/4	0.510	1/2	0.810	1 1/8	1 1/16	8 1/4	2 3/4 <sup>g</sup>
×26	7.61	10.3	10 3/8	0.260	1/4	1/8	5.77	5 3/4	0.440	7/16	0.740	1 1/16	1 1/16	8 1/4	2 3/4 <sup>g</sup>
×22 <sup>c</sup>	6.49	10.2	10 1/8	0.240	1/4	1/8	5.75	5 3/4	0.360	3/8	0.660	1 5/16	5/8	8 1/4	2 3/4 <sup>g</sup>
W10x19	5.62	10.2	10 1/4	0.250	1/4	1/8	4.02	4	0.395	3/8	0.695	1 5/16	5/8	8 3/8	2 1/4 <sup>g</sup>
×17 <sup>c</sup>	4.99	10.1	10 1/8	0.240	1/4	1/8	4.01	4	0.330	5/16	0.630	7/8	9/16	8 3/8	2 1/4 <sup>g</sup>
×15 <sup>c</sup>	4.41	10.0	10	0.230	1/4	1/8	4.00	4	0.270	1/4	0.570	1 13/16	9/16	8 3/8	2 1/4 <sup>g</sup>
×12 <sup>c,f</sup>	3.54	9.87	9 7/8	0.190	3/16	1/8	3.96	4	0.210	3/16	0.510	3/4	9/16	8 3/8	2 1/4 <sup>g</sup>

<sup>c</sup> Shape is slender for compression with  $F_c = 50$  ksi.  
<sup>f</sup> Shape exceeds compact limit for flexure with  $F_c = 50$  ksi.  
<sup>g</sup> The actual size, combination, and orientation of fastener components should be compared with the geometry of the cross-section to ensure compatibility.  
<sup>v</sup> Shape does not meet the  $h/t_w$  limit for shear in Specification Section G2.1a with  $F_y = 50$  ksi.

AMERICAN INSTITUTE OF STEEL CONSTRUCTION  
(a)



**Table 1-5  
C Shapes  
Dimensions**

Shape	Area, A		Depth, d	Web			Flange		Distance			rs	ho		
	in. <sup>2</sup>			Thickness, tw	tw/2	Width, bf	Thickness, tf	k	T	Workable Gage					
	in.	in.									in.			in.	in.
C15x50	14.7	15.0	15	0.716	1 1/16	3/8	3.72	3 3/4	0.650	5/8	1 7/16	12 1/8	2 1/4	1.17	14.4
×40	11.8	15.0	15	0.520	1/2	1/4	3.52	3 1/2	0.650	5/8	1 7/16	12 1/8	2	1.15	14.4
×33.9	10.0	15.0	15	0.400	3/8	3/16	3.40	3 3/8	0.650	5/8	1 7/16	12 1/8	2	1.13	14.4
C12x30	8.81	12.0	12	0.510	1/2	1/4	3.17	3 1/8	0.501	1/2	1 1/8	9 3/4	1 3/4 <sup>g</sup>	1.01	11.5
×25	7.34	12.0	12	0.387	3/8	3/16	3.05	3	0.501	1/2	1 1/8	9 3/4	1 3/4 <sup>g</sup>	1.00	11.5
×20.7	6.08	12.0	12	0.282	5/16	3/16	2.94	3	0.501	1/2	1 1/8	9 3/4	1 3/4 <sup>g</sup>	0.983	11.5
C10x30	8.81	10.0	10	0.673	1 1/16	3/8	3.03	3	0.436	7/16	1	8	1 3/4 <sup>g</sup>	0.925	9.56
×25	7.34	10.0	10	0.526	1/2	1/4	2.89	2 7/8	0.436	7/16	1	8	1 3/4 <sup>g</sup>	0.911	9.56
×20	5.87	10.0	10	0.379	3/8	3/16	2.74	2 3/4	0.436	7/16	1	8	1 1/2 <sup>g</sup>	0.894	9.56
×15.3	4.48	10.0	10	0.240	1/4	1/8	2.60	2 5/8	0.436	7/16	1	8	1 1/2 <sup>g</sup>	0.869	9.56
C9x20	5.87	9.00	9	0.448	7/16	1/4	2.65	2 5/8	0.413	7/16	1	7	1 1/2 <sup>g</sup>	0.848	8.59
×15	4.41	9.00	9	0.285	5/16	3/16	2.49	2 1/2	0.413	7/16	1	7	1 3/8 <sup>g</sup>	0.824	8.59
×13.4	3.94	9.00	9	0.233	1/2	1/8	2.43	2 1/8	0.413	7/16	1	7	1 3/8 <sup>g</sup>	0.813	8.59
C8x18.75	5.51	8.00	8	0.487	1/2	1/4	2.53	2 1/2	0.390	3/8	1 5/16	6 1/8	1 1/2 <sup>g</sup>	0.800	7.61
×13.7	4.04	8.00	8	0.303	5/16	3/16	2.34	2 3/8	0.390	3/8	1 5/16	6 1/8	1 3/8 <sup>g</sup>	0.774	7.61
×11.5	3.37	8.00	8	0.220	1/4	1/8	2.26	2 1/4	0.390	3/8	1 5/16	6 1/8	1 3/8 <sup>g</sup>	0.756	7.61
C7x14.7	4.33	7.00	7	0.419	7/16	1/4	2.30	2 1/4	0.366	3/8	7/8	5 1/4	1 1/4 <sup>g</sup>	0.738	6.63
×12.2	3.60	7.00	7	0.314	5/16	3/16	2.19	2 1/4	0.366	3/8	7/8	5 1/4	1 1/4 <sup>g</sup>	0.721	6.63
×9.8	2.87	7.00	7	0.210	3/16	1/8	2.09	2 1/8	0.366	3/8	7/8	5 1/4	1 1/4 <sup>g</sup>	0.698	6.63
C6x13	3.81	6.00	6	0.437	7/16	1/4	2.16	2 1/8	0.343	5/16	1 3/16	4 3/8	1 3/8 <sup>g</sup>	0.689	5.66
×10.5	3.08	6.00	6	0.314	5/16	3/16	2.03	2	0.343	5/16	1 3/16	4 3/8	1 1/8 <sup>g</sup>	0.669	5.66
×8.2	2.39	6.00	6	0.200	3/16	1/8	1.92	1 7/8	0.343	5/16	1 3/16	4 3/8	1 1/8 <sup>g</sup>	0.643	5.66
C5x9	2.64	5.00	5	0.325	5/16	3/16	1.89	1 7/8	0.320	5/16	3/4	3 1/2	1 1/8 <sup>g</sup>	0.617	4.68
×6.7	1.97	5.00	5	0.190	3/16	1/8	1.75	1 3/4	0.320	5/16	3/4	3 1/2	—	0.584	4.68
C4x7.2	2.13	4.00	4	0.321	5/16	3/16	1.72	1 3/4	0.296	5/16	3/4	2 1/2	1 <sup>g</sup>	0.563	3.70
×5.4	1.58	4.00	4	0.184	3/16	1/8	1.58	1 5/8	0.296	5/16	3/4	2 1/2	—	0.528	3.70
×4.5	1.38	4.00	4	0.125	1/8	1/16	1.58	1 5/8	0.296	5/16	3/4	2 1/2	—	0.524	3.70
C3x6	1.76	3.00	3	0.356	3/8	3/16	1.60	1 5/8	0.273	1/4	1 1/16	1 5/8	—	0.519	2.73
×5	1.47	3.00	3	0.258	1/4	1/8	1.50	1 1/2	0.273	1/4	1 1/16	1 5/8	—	0.495	2.73
×4.1	1.20	3.00	3	0.170	3/16	1/8	1.41	1 3/8	0.273	1/4	1 1/16	1 5/8	—	0.469	2.73
×3.5	1.09	3.00	3	0.132	1/8	1/16	1.37	1 3/8	0.273	1/4	1 1/16	1 5/8	—	0.455	2.73

<sup>g</sup> The actual size, combination, and orientation of fastener components should be compared with the geometry of the cross-section to ensure compatibility.  
 — Flange is too narrow to establish a workable gage.

AMERICAN INSTITUTE OF STEEL CONSTRUCTION  
(b)

**FIGURE 22.56** Dimensional information for (a) W 12 × 22 and (b) C 6 × 10.5. Courtesy American Institute for Steel Construction, *Manual of Steel Construction*. Additional samples of structural steel dimensions area found in Appendix E. *Courtesy American Institute of Steel Construction*

The structural steel shapes that fall into this category are as follows:

- W—wide flange shapes
- S—American standard beams
- M—miscellaneous beam and column shapes
- C—American standard channels
- MC—miscellaneous channel shapes
- WT—structural tees cut from W shapes
- ST—structural tees cut from S shapes

- MT—structural tees cut from M shapes
- T—structural tees
- Z—zee shapes
- HP—steel H piling

The specifications for square and rectangular structural steel tubing, and sample structural steel shape designations, are provided in Appendices U and V.

Structural materials that are specified by shape designation, type, diameter or outside dimension, and wall thickness are in the following table.



**NOTE:** If length dimensions are required, they are given at the end of the callout in feet and inches except for plates, which should be given only in inches.

Designation	Shape	Example	Meaning
PL	Plate	PL 1/2 × 6 × 8	THK × WIDTH × LENGTH
BAR	Square bar	BAR 1-1/4 □*	1-1/4" WIDTH × THICKNESS
	Round bar	BAR 1-1/4 Ø	1-1/4" DIAMETER
	Flat bar	BAR 2 × 3/8	WIDTH × THICKNESS
PIPE	Pipe	PIPE 3ØSTD	OD [OUTSIDE DIA] SPEC
TS	Structural tubing		
	Square	TS 4 × 4 × .250	OUTWIDTH × OUTHEIGHT × WALL THICKNESS
	Rectangular	TS 6 × 3 × .375	SAME
	Round	TS 4 OD × .188	OD × WALL THICKNESS
L	Angle		
	Unequal leg	L3 × 2 × 1/4	LEG × LEG × THICKNESS
	Equal leg	L3 × 3 × 1/2	LEG × LEG × THICKNESS

\*Some companies use □ for the square symbol.

When plate material is bent, the minimum bend radius should be given with the plate callout, and the length of the bend legs are dimensioned on the drawing. For example,

$$3/8 \times 10 \text{ W/MIN BEND R } 5/8''$$

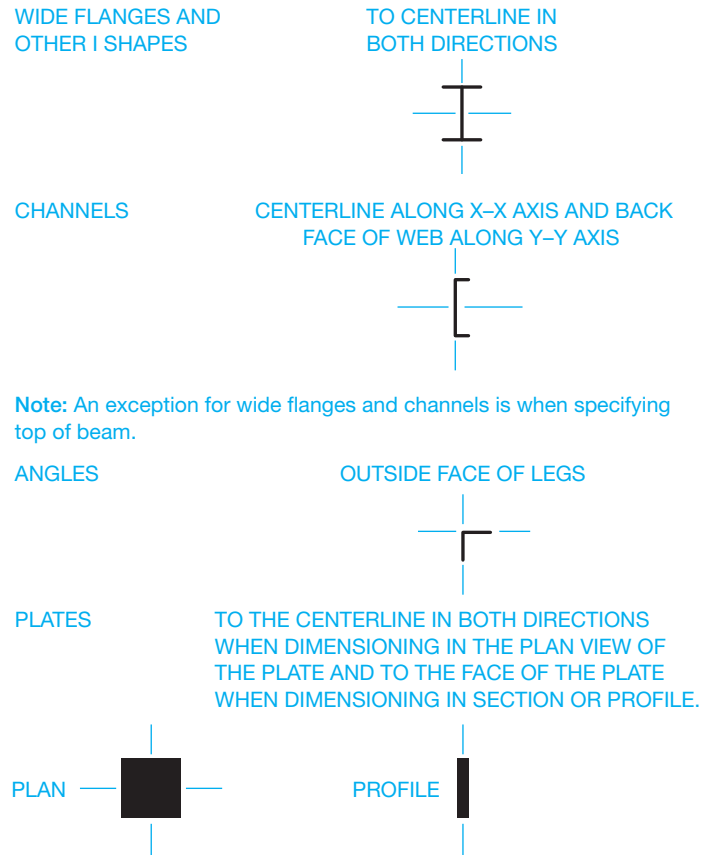
**Location dimensions** for structural steel components should be drawn as shown in Figure 22.57. Drafters in architectural or structural engineering firms typically draw structural drawings as shown in Figure 22.58.

## Shop Drawings

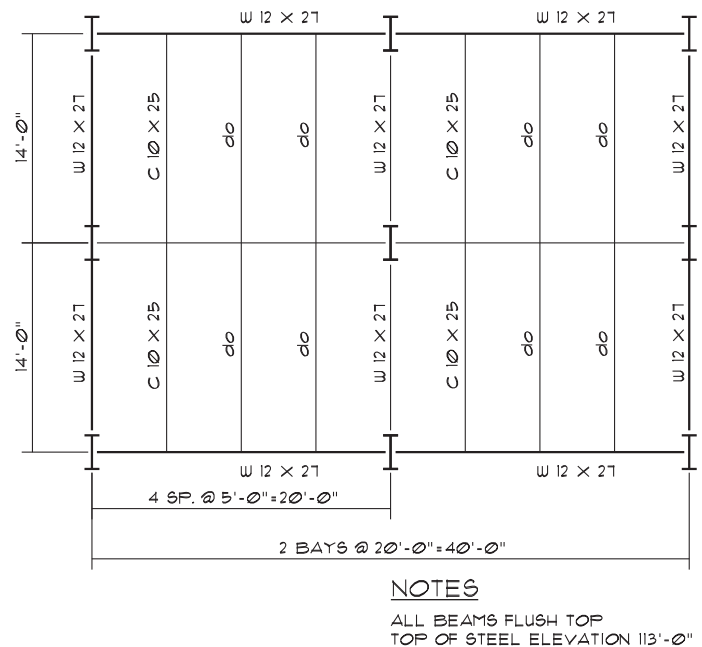
**Shop drawings** are used to break each individual component of a structural engineering drawing down into fabrication parts. Shop drawings are also referred to as **fabrication drawings** and are generally drawn by the drafter in the fabrication company. Many large companies do both structural and shop drawings. Depending on the complexity of the structure, the structural and shop drawings can be combined on the same drawing. Figure 22.59 shows an example of a shop drawing.

## COMMON CONNECTION METHODS

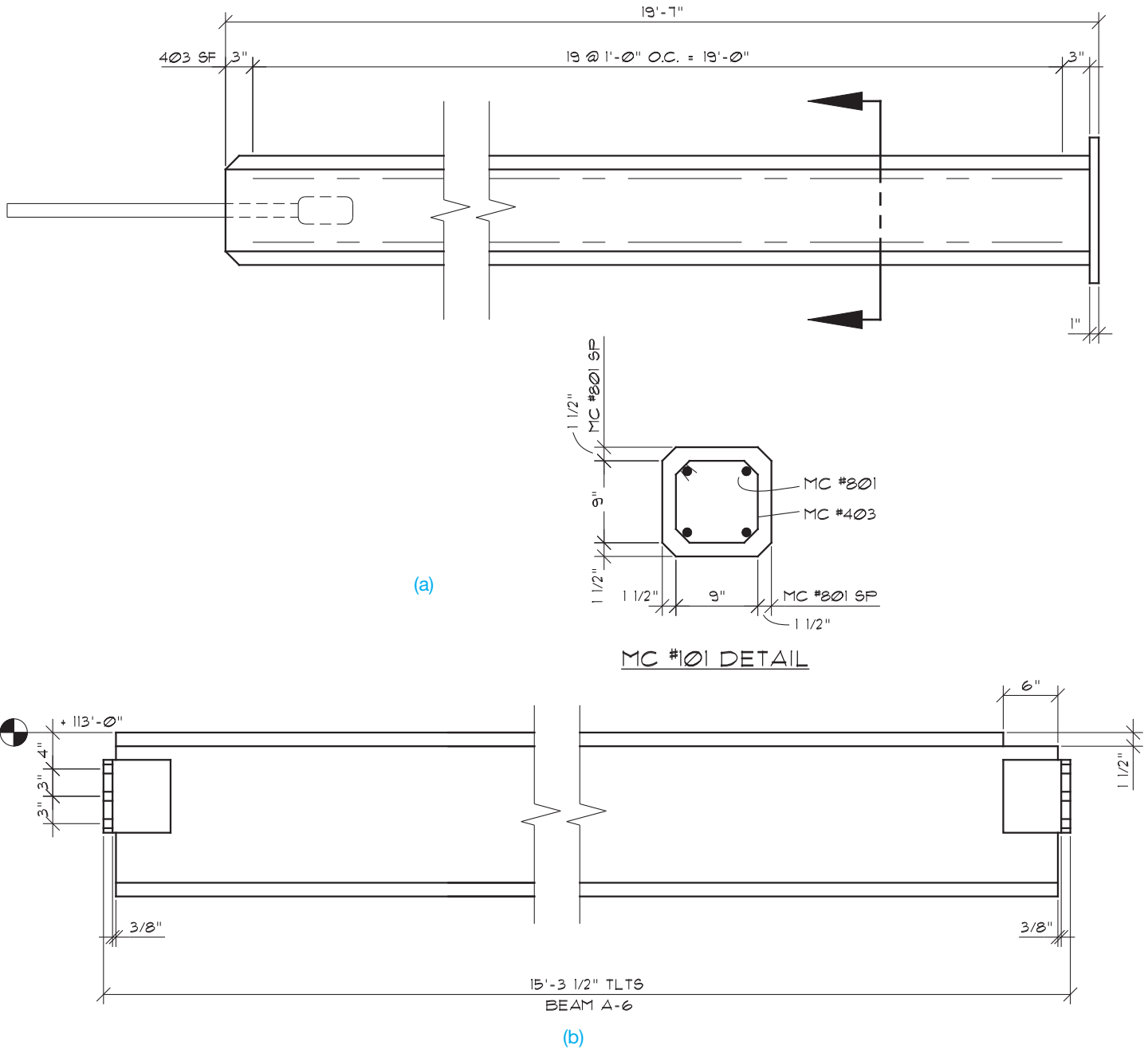
There are a variety of common connection methods for steel construction, including bolted, nailed, and welded connections.



**FIGURE 22.57** Location dimensions for structural components. © Cengage Learning 2012



**FIGURE 22.58** Structural steel engineering drawing. © Cengage Learning 2012



**FIGURE 22.59** (a) Precast concrete fabrication detail. (b) Structural steel fabrication drawing used to show how individual components are to be made. © Cengage Learning 2012

## Bolted Connections

**Bolts** are used for many connections in lumber and steel construction. A bolt specification includes the diameter, length, and strength of the bolt. Washers or plates are specified so the bolt head will not pull through the hole made for the bolt.

## STANDARDS

**ASTM Bolt strength** is classified in accordance with the ASTM specifications. Refer to Chapter 11, *Fasteners and Springs*, for more information.

## Standard Structural Bolt Callouts

When specifying bolts on a drawing, give the quantity, diameter, bolt type if special, length in inches, and ASTM specification. If special washer and nut requirements are required, then this should also be specified in the bolt callout. Hexagon head bolts and hexagon nuts are assumed unless either is specified differently in the callout. Examples of bolt callouts are:

- 2-3/4" Ø BOLTS ASTM A503
- 4-1/2" Ø × 10" BOLTS
- 2-5/8" Ø × 6" CARRIAGE BOLTS
- 6-3/4" Ø BOLTS W/MALLEABLE IRON WASHERS AND HEAVY HEX NUTS
- 4-1/2" Ø GALVANIZED BOLTS

Give the hole diameter when holes for standard bolts must be specified on the drawing. In general, holes should be 1/16" (1.5 mm) larger in diameter than the specified bolt for standard steel-to-steel, wood-to-wood, or wood-to-steel construction for hole sizes up to 1" (25 mm) in diameter, and 1/8" (3 mm) larger for hole sizes over 1" in diameter. Holes should be 1/8" (3 mm) larger than the specified bolt for standard steel-to-concrete or wood-to-concrete applications unless otherwise specified by the engineer. For example,

2-3/4" Ø BOLTS FIELD DRILL 13/16" Ø HOLES

Refer to Chapter 11, *Fasteners and Springs*, for bolt and fastener terminology and types and refer to Appendixes J through P for additional fastener specifications.

The following are recommended standard hole diameters in inches for given bolt sizes.

Bolt Ø	Standard Hole Ø	Concrete Hole Ø	Oversize Hole Ø
1/2	9/16	5/8	11/16
5/8	11/16	3/4	13/16
3/4	13/16	7/8	15/16
7/8	15/16	1	1 1/16
1	1 1/16	1 1/8	1 1/4
1 1/8	1 1/4	1 1/4	1 7/16
1 1/4	1 3/8	1 3/8	1 9/16
1 3/8	1 1/2	1 1/2	1 11/16
1 1/2	1 5/8	1 5/8	1 13/16

When specifying lag bolts on a drawing, the lead or tap hole diameter should be given with the bolt specification. For example,

2-3/4" Ø × 8 LAG BOLTS W/7/16" Ø LEAD HOLES

The following are tap hole diameters in inches for lag bolts used in Douglas fir, larch, or Southern pine.

Bolt Ø	Lead Hole Ø
3/8	1/4
1/2	5/16
5/8	7/16
3/4	1/2
7/8	5/8
1	3/4

Bolts, on a drawing, are located to their centerlines. When counterbores are required, provide the specification to the location of the counterbore. For example,

Ø 2-3/4" BOLT Ø 3-1/4" CBORE × 7/8" DEEP

ASME Y14.5-2009 symbols for counterbore and depth can also be used. (See Chapter 10, *Dimensioning and Tolerancing*.)

## Nailed Connections

**Nails** used for the fabrication of wood-to-wood members are sized by the term **penny** and denoted by the letter **d**. Penny is a weight classification for nails based on the number of pounds per 1000 nails. For example, one thousand 16d nails weigh 16 pounds. Nails are also sized by diameter when over 60d. Figure 22.60 shows standard nail sizes (2d to 20d) and nail types. When specifying nails, the penny weight should be given plus the quantity and spacing if required. The specification for special nails should be given when required. Nailing callout examples include:

- 4-16d NAILS
- 5-20d GALV NAILS EA SIDE
- 10d NAILS 4" OC AT SEAMS AND 12" OC IN FIELD
- 30d NAILS ALTERNATELY STAGGERED 12" OC TOP AND BOTTOM BOTH SIDES
- 8d RING SHANK NAILS 6" OC

If pilot holes are required for nailing, the diameter of the pilot hole should be given after the nail callout. For example,

4-20d NAILS W/5/32" Ø HOLES

Verify pilot hole diameters with manufacturers' recommendations for types of woods and applications.

## Welded Connections

**Welds** are classified according to the type of joint on which they are used. The four common welds used in construction are the fillet, back, plug or slot, and groove welds. A welding symbol is used to designate the type and dimensional specifications of the weld. Review Chapter 18, *Welding Processes and Representations*, for in-depth coverage of welding symbols before doing the drawings in this chapter.

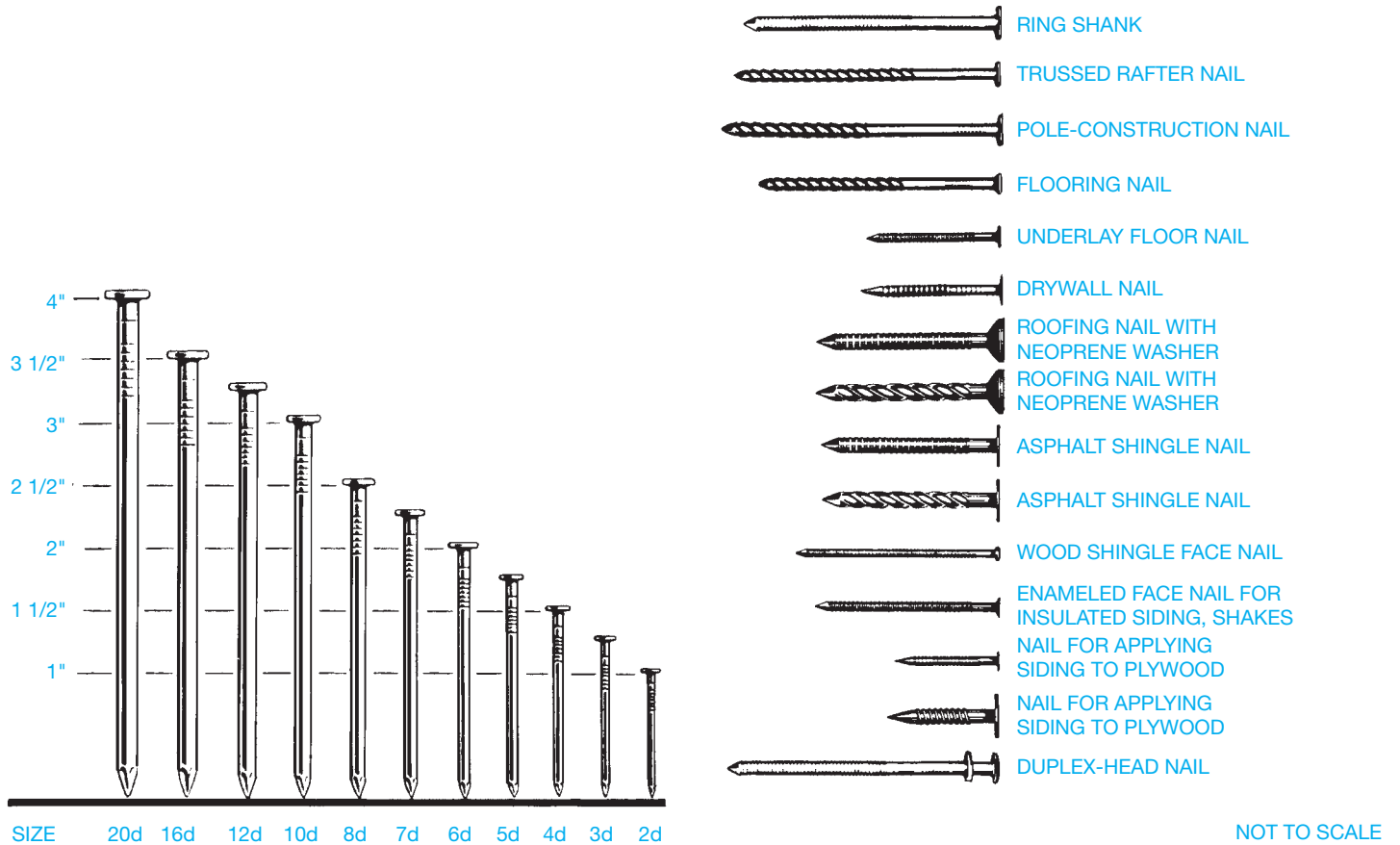


FIGURE 22.60 Standard nail sizes and types. © Cengage Learning 2012

### Fabrication Methods

There are an unlimited number of fabrication methods. As a structural drafter you must become familiar with the fabrications used on construction projects. Many techniques are typical, whereas others require special design. The drafter either draws from engineering sketches or refers to previously drawn

examples. Once a certain amount of experience has been gained, the drafter is able to establish drawings from either written or oral instruction or from a particular given situation.

### STANDARDS

**AISC** The *AISC Manual of Steel Construction* provides a number of common connection details.

## GREEN TECHNOLOGY APPLICATION

### THE LEED™ PROGRAM

The U.S. Green Building Council (USGBC) members came together to create a standard for green building called the Leadership in Energy and Environmental Design (LEED™) Green Building Rating System™. This rating system is a national standard for developing high-performance sustainable buildings. *Sustainable buildings* are

buildings capable of maintaining their desired function into the future. LEED represents every part of the construction industry. As taken from the USGBC Web site, LEED was created to:

- Define **green building** by establishing a common standard of measurement.
- Promote integrated, whole-building design practices.



- Recognize environmental leadership in the building industry.
- Stimulate green competition.
- Raise consumer awareness of green building benefits.
- Transform the building market.

Green building, also known as **green construction** or **sustainable building**, is the practice of creating structures and using processes that are environmentally responsible and resource efficient throughout a building's life cycle, including site selection and preparation, design, construction, operation, maintenance, renovation, and deconstruction. LEED has a commercial building certification program that started in 2000 that sets apart commercial construction projects demonstrating the highest sustainability performance standards. LEED certification requires that the project meet the fundamentals and score a minimum number of points in a LEED rating system. In the LEED program, various levels of certification are applied to new buildings and rehabilitated structures. The objective is for the building to earn enough points to qualify for platinum, gold, or silver levels of certification.

## LEED GREEN BUILDING GUIDELINES

The LEED Green Building Rating System is a leader of environmentally friendly design and construction. Incorporating the MasterFormat numbering system, the guidelines are designed to help improve the quality of buildings and to minimize their impact on the environment. The rating system, developed by the USGBC, is intended to blend the structure with the environment, reduce operating costs, and aid in marketing the structure for resale. LEED certification requires that the project meet the fundamentals and score a minimum number of points in a LEED rating system. LEED certification acknowledges four different levels of certification including:

- Certified, 26–32 points.
- Silver, 33–38 points.
- Gold, 39–51 points.
- Platinum, 52 points or more.

Key areas of the construction process and their corresponding CSI MasterFormat 2004 division number that are covered by the LEED rating system include the following.

### Sustainable Sites

This area of credits is applied to efficient design and construction as it relates to the construction site. Although the

standard is intended for residential design, many of these specific credits are best applied to multifamily design.

### Water Efficiency

Three credits are available related to the use and reduction of the use of water in the structure and at the building site.

### Indoor Environmental Quality

Eight credits are available related to the interior air quality of the structure.

### Energy and Atmosphere

Six credits are available related to the use of energy to control the atmosphere within a residence.

### Material and Resources

Seven credits are available that are related to the materials and products used to build and sustain a structure.

### Innovation and the Design Process

Two credits are available that are related to the design phase of a residence.

## STEEL AND ALUMINUM IN GREEN CONSTRUCTION

The International Aluminum Institute (IAI) ([www.world-aluminum.org](http://www.world-aluminum.org)), American Iron and Steel Institute (AISI) ([www.steel.org](http://www.steel.org)), and the American Institute of Steel Construction (AISC) supply the following information.

### STEEL IN GREEN CONSTRUCTION

Designers and builders have long recognized and praised steel for its strength, durability, and functionality. Increasingly, however, architects are recognizing steel's important environmental attributes, especially its high recycled content and high reclamation rate. For many years, there has been a strong economic motive to incorporate recycling into the process for making steel, but today's environmental concerns make recycling even more important. Recycling saves money while conserving energy and resources, as well as reducing solid, liquid, and gaseous wastes. Recycling also helps to spread the energy impact of the original extraction and

manufacturing of the material over unlimited generations of new steel.

In the construction industry, recent interest in recycling has been driven largely by the U.S. Green Building Council's LEED rating system previously described. The LEED rating system only promotes the use of materials with high levels of recycled content. The equally important reclamation rate of the materials is not currently considered.

The amount of recycled content in steel products varies over time, both as a function of the cost of steel scrap and its availability. As the worldwide demand for steel increases, the available scrap will be stretched between more and more steel products, meaning that more raw steel will have to enter the production stream to meet the demand. Fortunately, steel is the country's most widely recycled material, and as more steel is used for construction and other products, more scrap is available for future recycling. At the end of their useful life, about 88% of all steel products and nearly 100% of structural steel beams and plates used in construction are recycled into new products—an amazing reclamation rate.

Another way that steel can contribute toward several LEED credits, both directly and indirectly, is that it is dimensionally stable, and, when properly designed, can provide for exceptional air-tight building envelope, resulting in less air loss and better HVAC performance. On-site waste is reduced because it can be made to exact specifications. When a building is demolished, the steel from the demolition can be easily recycled; because of its magnetic properties, the separation of other materials from the steel is greatly facilitated.

As with anything in the construction industry, there is always room for improvement. What LEED does is help the steel industry recover even more scrap as contractors improve their recycling collection methods at the job site so less iron and steel ends up in landfills.

The following factors help steel contribute to LEED and green construction:

- Highest strength-to-weight ratio of any building material.
- 100% recyclable.
- 68% industry recycling rate.

## ALUMINUM IN GREEN CONSTRUCTION

As with steel, the United States aluminum product line can help new commercial construction and major renovation projects (LEED-NC), existing building operations (LEED-EB), commercial interiors projects (LEED-CI), and core and

shell projects (LEED-CS) attain points toward one of the four levels of LEED certification: basic, silver, gold, and platinum.

Metal architects are able to create amazing building exteriors that are pleasing to the eye and good for the environment. Custom aluminum fabricators like aluminum because it offers virtually limitless possibilities with its ductile properties and ability to retain coatings and finishes. Because aluminum has many benefits to the world of architecture, its key benefits are its reusability and cost effectiveness for businesses.

Although aluminum is the most abundant metal on Earth, there are no mines in the United States that harvest bauxite, the mineral from which aluminum is derived. All of the mined aluminum in the United States is imported from locations around the globe, costing millions of dollars and expending other resources. If aluminum is not mined from elsewhere, it is recycled at about 5% of the energy that it takes to remove it from the ground, extract it from a bauxite ore, and ship it across the world. Recycled aluminum is a cost-effective alternative for numerous industries, especially for metal architectural firms, construction companies, and their clients.

The following are some facts about aluminum and its contribution to LEED and green construction.

### Recyclability

Aluminum used in the building and construction industry contains a high percentage of postconsumer and postindustrial recycled content. At the end of its long, useful life in your building application, it is 100% recyclable. Aluminum building components can be repeatedly recycled back into similar products with no loss of quality, and aluminum in its various forms provides the most valuable component for most municipal recycling efforts. The recycling of postconsumer aluminum saves 80 million tons of CO<sub>2</sub> annually and achieves among the highest recycling rates of materials.

### Recycled Content

A survey of aluminum producers in mid-2008 indicated that the total recycled content of domestically produced, flat rolled products for the building and construction market was approximately 85%. The survey of the producers also indicated that, on average, ~60% of the total product content is from postconsumer sources. Although these numbers represent the industry average, higher postconsumer and total recycled content material may be available from individual producers.

## COMPONENTS IN A SET OF STRUCTURAL DRAWINGS

A **set of structural drawings** can have a number of sheets with specific elements of the building provided in a general format or with specific construction elements shown in cross sections or in detail. Although not all complete sets of structural drawings contain the same number of sheets or type of information, some of the representative drawings include a floor plan, a foundation plan and details, a concrete slab plan and details, a roof framing plan and details, a roof drainage plan, building section(s), exterior elevations, a panel plan, elevations, and wall details.

### Floor Plan

The **floor plan** is generally designed and drawn by the architect. The floor plan drawing is then used as the layout for the other associated drawings from consulting engineers—for example, the mechanical (HVAC), plumbing, electrical, and structural engineers. In some situations and depending on the structure, the structural engineering firm draws the floor plan as part of the set of drawings (see Figure 22.61).

### Foundation Plan and Details

The purpose of the **foundation plan** is to show the supporting system for the walls, floor, and roof. The foundation can consist of continuous perimeter footings and walls that support the exterior and main bearing walls of the building. The footings in these locations are rectangular in shape and are continuous concrete supports centered at exterior and interior bearing walls. (See Figure 22.62.) There are also pedestal footings that support the concentrated loads of particular elements of the structure. Interior support for the columns that support upper floor and roof loads are provided by pedestal footings as shown in Figure 22.63. Anchor bolts and other metal connectors are shown and located on the foundation plan, as shown in Figure 22.64. A concrete slab foundation plan is shown in Figure 22.65.

The **foundation details** are drawn to provide information on the concrete foundation at the perimeter walls, and the foundation and pedestals at the center support columns. Possible details include retaining walls, typical exterior foundation and rebar schedule, typical interior bearing wall, and typical pedestal and rebar schedule. Detail drawings are keyed to the plan view using detail markers. Detail markers are usually drawn as a circle of about 3/8" to 1/2" (9.5–13 mm) in diameter on the plan view and a coordinating circle of about 3/4" (19 mm) in diameter under the associated detail. Each detail marker is divided in half. The top half contains the detail number and the bottom identifies the page number on which the detail is drawn. Notice the detail markers associated with the example drawings in this chapter. The **rebar**

**schedules** are charts placed next to the detail that key to the drawing information about the rebar used in the detail as shown in Figure 22.63.

### Concrete Slab Plan and Details

The **concrete slab plan** is drawn to outline the concrete used to construct the floor(s). Items often found in slab plans include floor slabs, slab reinforcing, expansion joints, pedestal footings, metal connectors, anchor bolts, and any foundation cuts for doors or other openings. The openings and other items are located and labeled on the plan, as shown in Figure 22.66. In situations where tilt-up construction is used, the opening locations are dimensioned on the elevations.

The **concrete slab details** are drawn to provide information of the intersections of the concrete slabs. These details include interior and perimeter slab joints as in Figure 22.67 and other slab details. The drawings include such information as slab thicknesses, reinforcing sizes and locations, and slab elevations (heights), as shown in Figure 22.68.

### Roof Framing Plan and Details

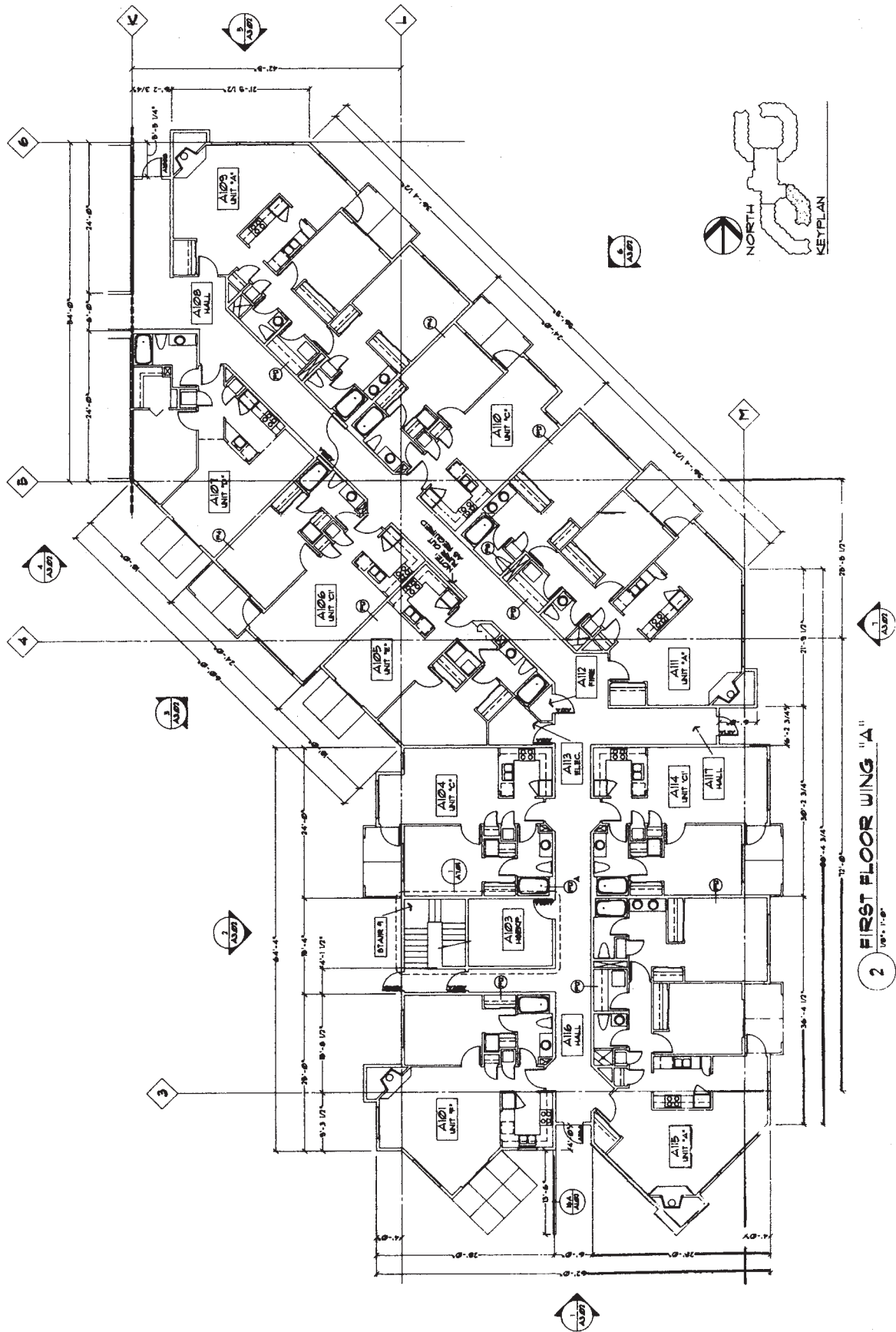
The purpose of the **roof framing plan** is to show the major structural components in plan view that occur at the roof level. Figure 22.33 shows a roof framing plan using truss framing. Figures 22.34 and 22.35 show a panelized roof framing plan.

**Roof framing details** are required to show the construction methods used at various member intersections in the building. Details can include the following intersections: wall to beam, beam to column, beam splices and connections, truss details, bottom chord bracing plan and details, purlin clips, cantilever locations, and roof drains (see Figure 22.69).

Notice the **elevation symbol** shown in Figure 22.69e. The elevation symbol is commonly used on structural drawings to give the elevation of locations from a known zero elevation. The zero elevation might be at the first floor or other good reference point such as the top of a foundation wall. Elevation symbols are used together with standard dimensioning practice as needed.

### Roof Drainage Plan

The **roof drainage plan** can be part of a set of structural drawings for some buildings, although it may be considered part of the plumbing or piping drawings, depending on the particular company's use and interpretation. The purpose of this drawing is to show the elevations of the roof and provide for adequate



**FIGURE 22.61** CADD floor plan for a set of construction drawings. Courtesy Soderstrom Architects

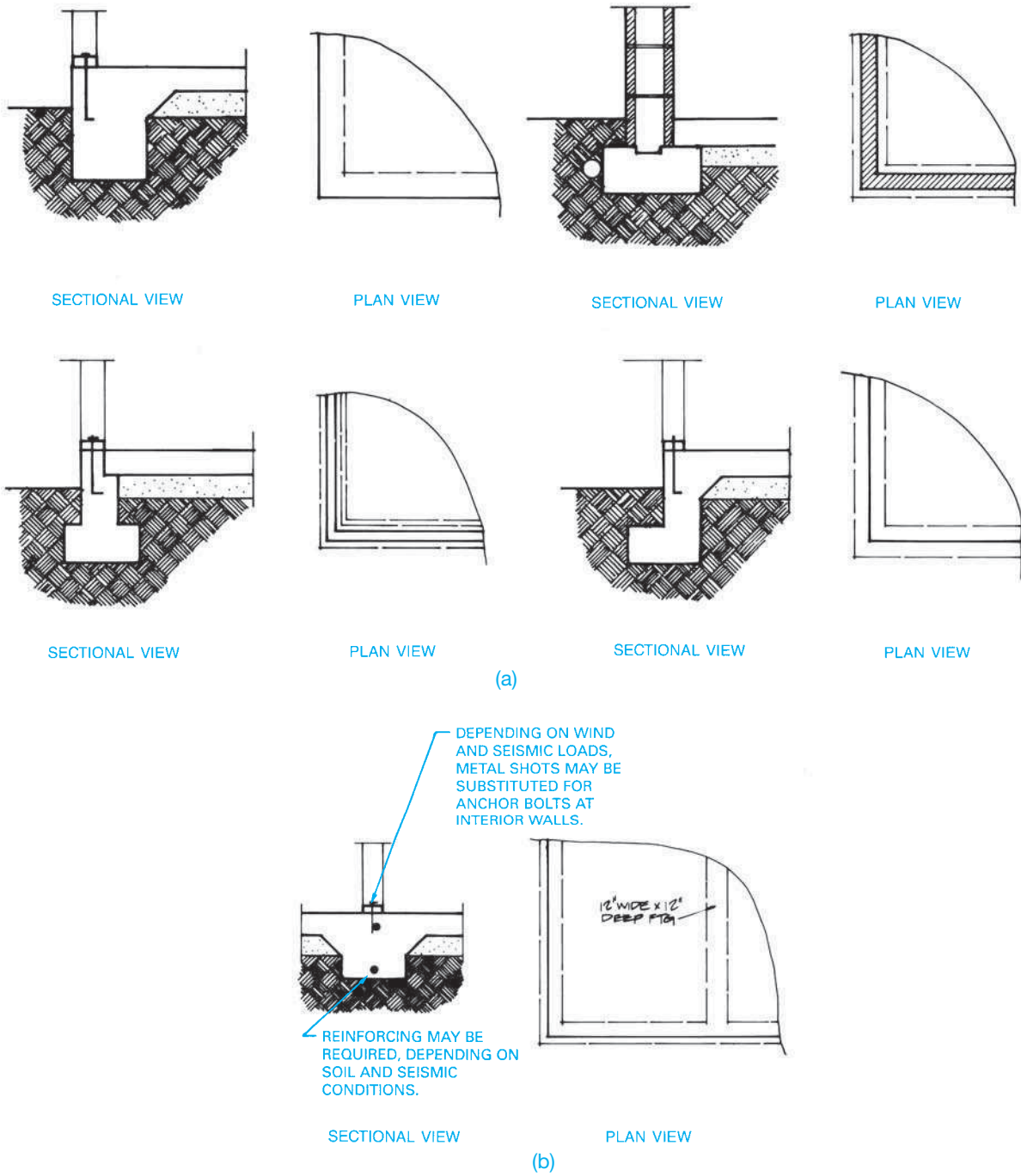
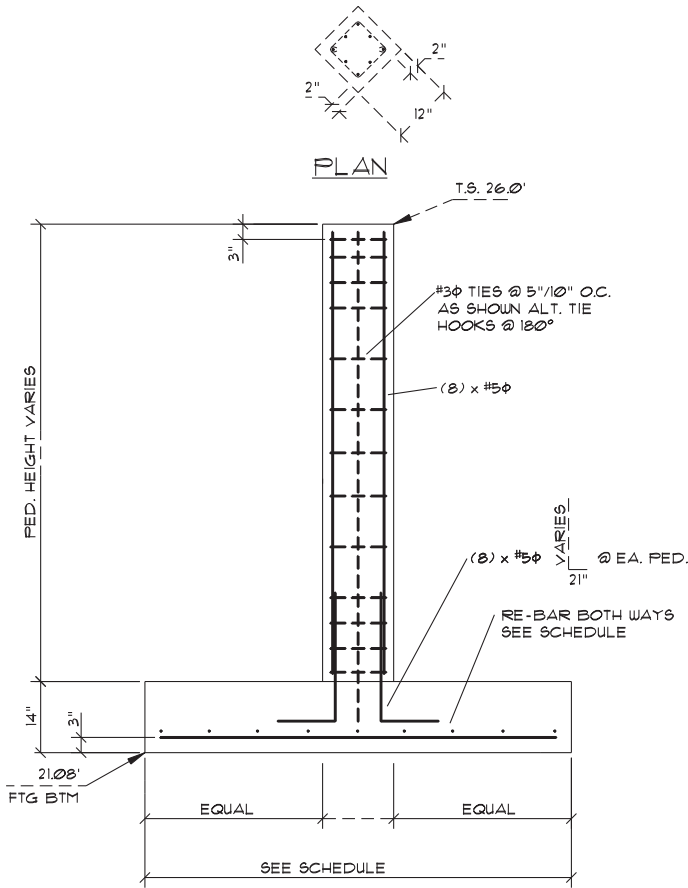


FIGURE 22.62 (a) Common foundation and slab intersections. (b) Footing and floor intersections at interior load-bearing wall.



FTG	PED HEIGHT	SIZE	REINFORCING STEEL
B-2	7.50	7'-0" $\square$	#6 $\phi$ @ 10" O.C.
B-3	6.75	6'-6" $\square$	#6 $\phi$ @ 12" O.C.
B-4	5.91	6'-6" $\square$	#6 $\phi$ @ 12" O.C.
B-5	5.00	7'-0" $\square$	#6 $\phi$ @ 10" O.C.

FIGURE 22.63 Pedestal footing detail. © Cengage Learning 2012

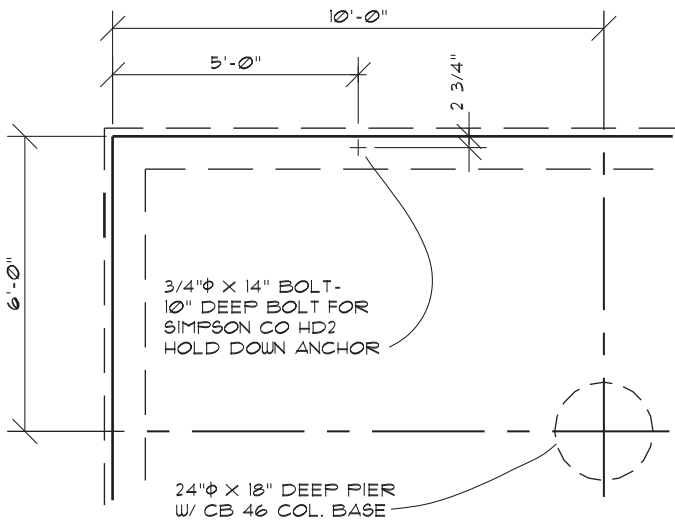


FIGURE 22.64 Foundation plan showing location of metal connectors. © Cengage Learning 2012

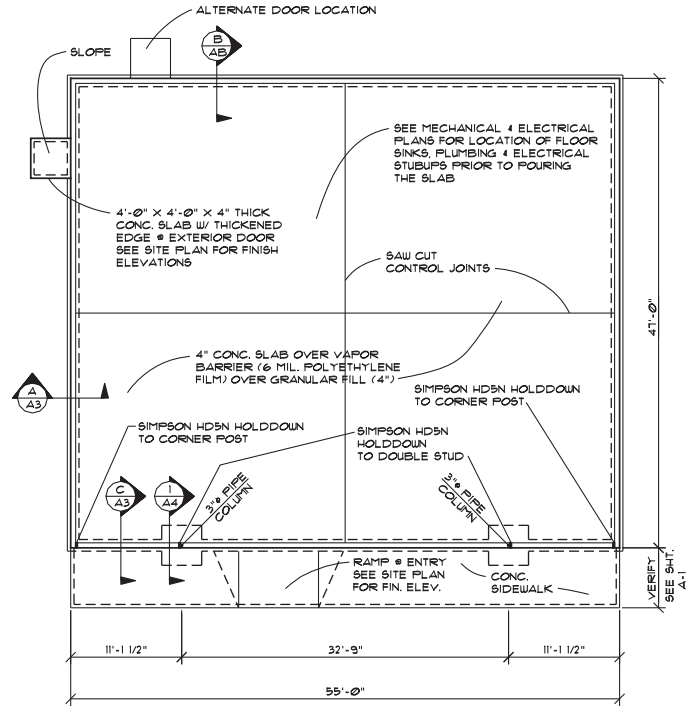


FIGURE 22.65 A concrete slab foundation is commonly used for commercial structures. Courtesy 7-Eleven, Inc.

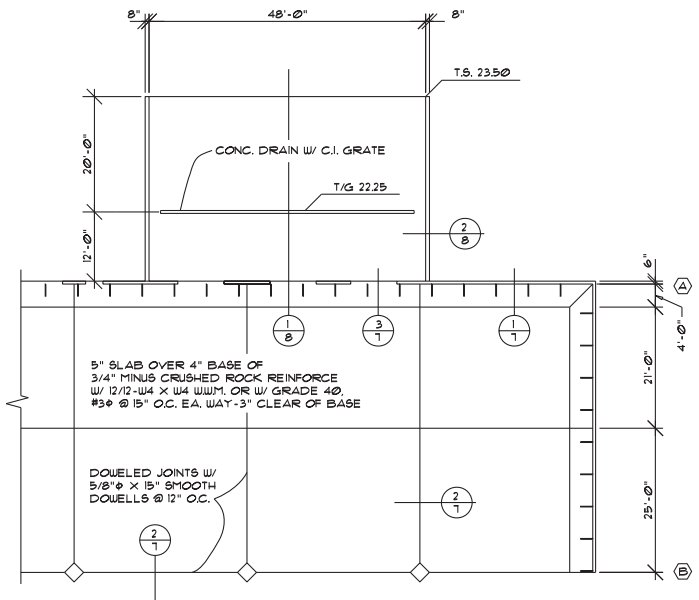
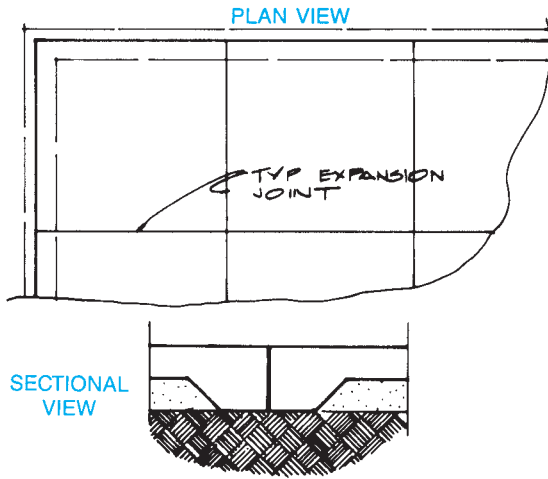


FIGURE 22.66 A slab-on-grade plan shows the size and location of all concrete pours plus reinforcing specification. Courtesy Structureform Masters Inc.



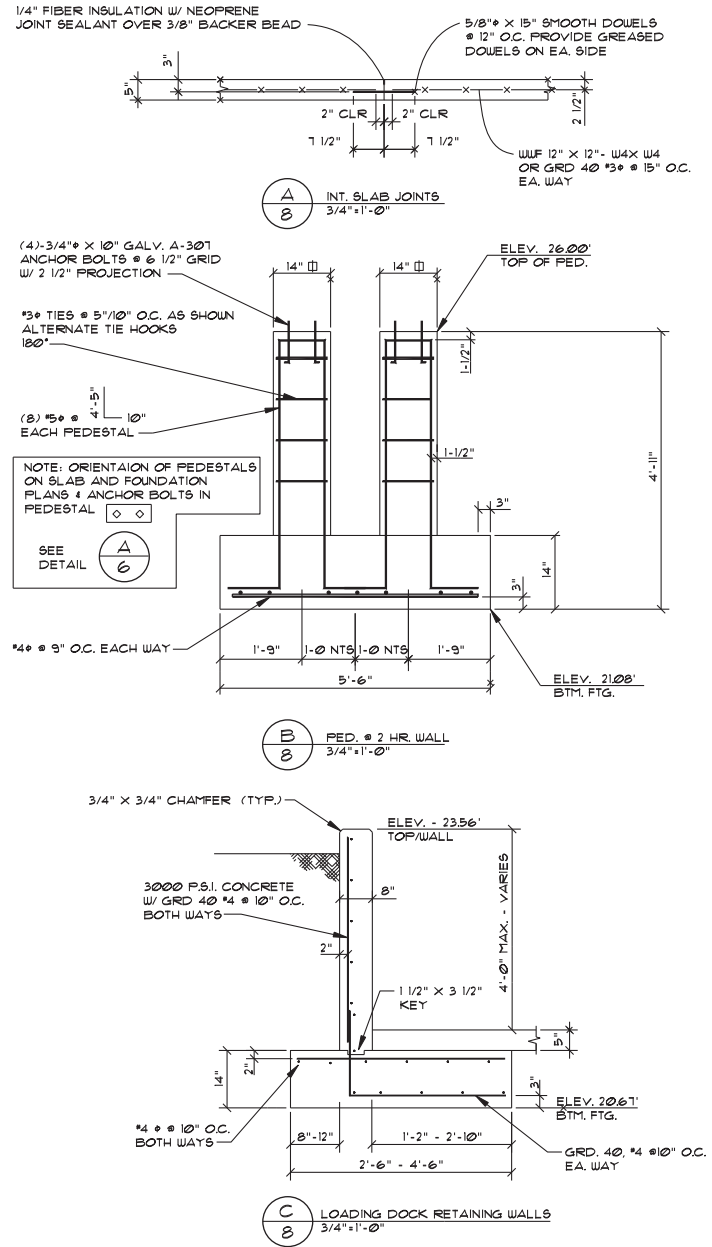
**FIGURE 22.67** Control joints are often placed in large slabs to resist cracking and allow construction crews manageable area in which to pour.

water drainage required on low slope and flat roofs (see Figure 22.70). Some of the terminology associated with roof drainage plans includes the following:

- Roof drain (RD)**—a screened opening to allow for drainage.
- Overflow drain (OD)**—a backup in case the roof drains fail.
- Down spout (DS)**—usually a vertical pipe used to transport water from the roof.
- Scupper or gutter**—a water collector usually on the outside of a wall at the roof level to funnel water from the roof drains to the downspouts.

### Building Sections

The **building section** is used to show the relationship between the plans and details previously drawn. This drawing is considered a general arrangement or construction reference, as it is often drawn at a small scale. Although some detailed information is provided with regard to building elevations (heights) and general dimensions, the overall section is not intended to provide explanation of building materials. The details more clearly serve this purpose, because they are drawn at a larger scale. Some less-complex buildings, however, may show a great deal of construction information on the overall section and use fewer details. These overall sections, commonly called **typical cross sections**, show the general arrangement of the construction and often have detail correlated to them (see Figure 22.71). In some situations, partial sections may be useful in describing portions of the construction that may not be effectively handled with the building section and may be larger areas than normally identified with a detailed section, as shown in Figure 22.72.

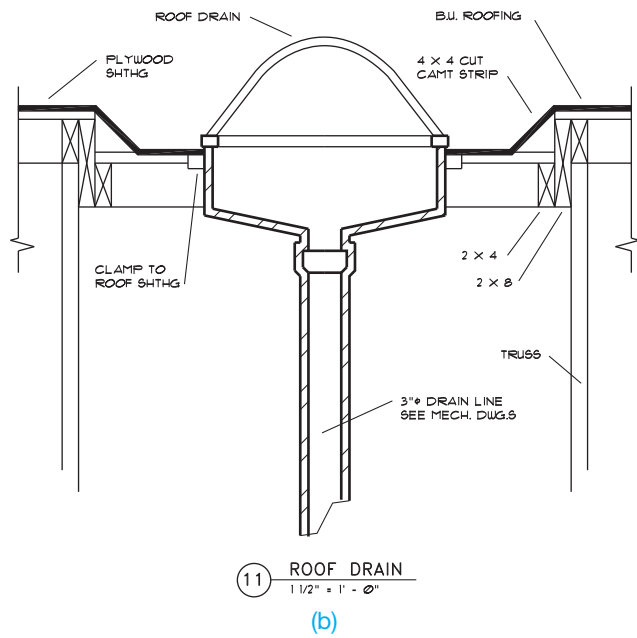
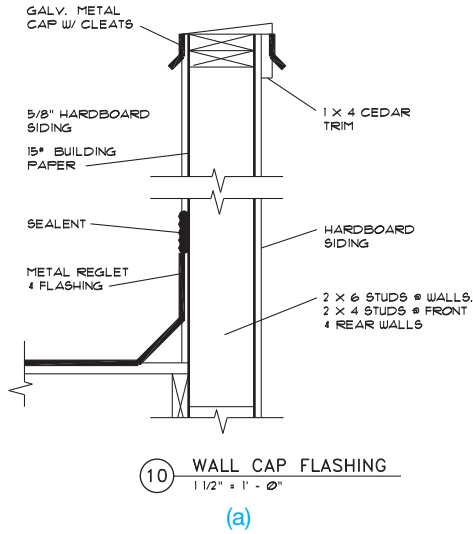


PEDESTAL/FOOTING		SCHEDULE	
FOOTING	PEDESTAL HEIGHT	SIZE	REINFORCING STEEL
B-2	7.50	7'-0" □	#6 @ 10" O.C.
B-3	6.75	6'-6" □	#6 @ 12" O.C.
B-4	5.91	6'-6" □	#6 @ 12" O.C.
B-5	5.00	7'-0" □	#6 @ 10" O.C.
B-6	4.50	6'-0" □	#5 @ 10" O.C.
B-7	4.00	7'-0" □	#6 @ 10" O.C.

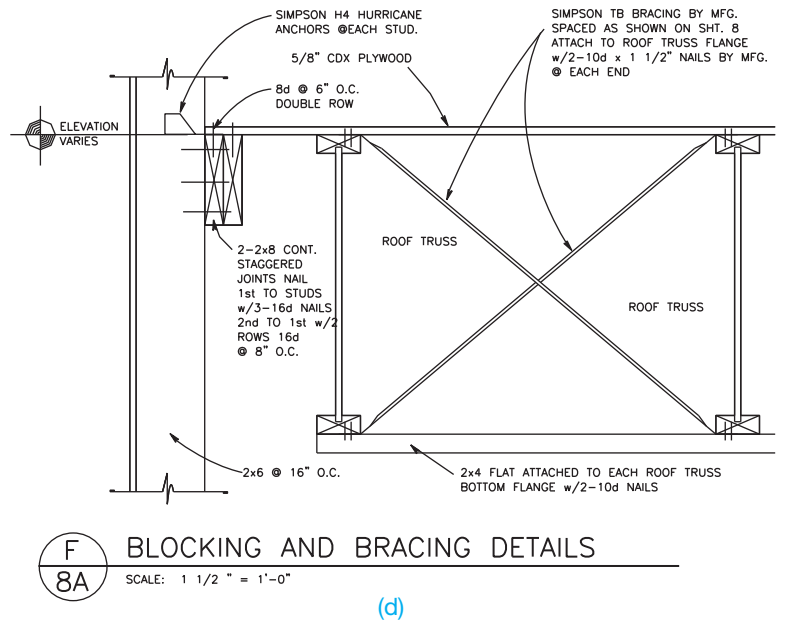
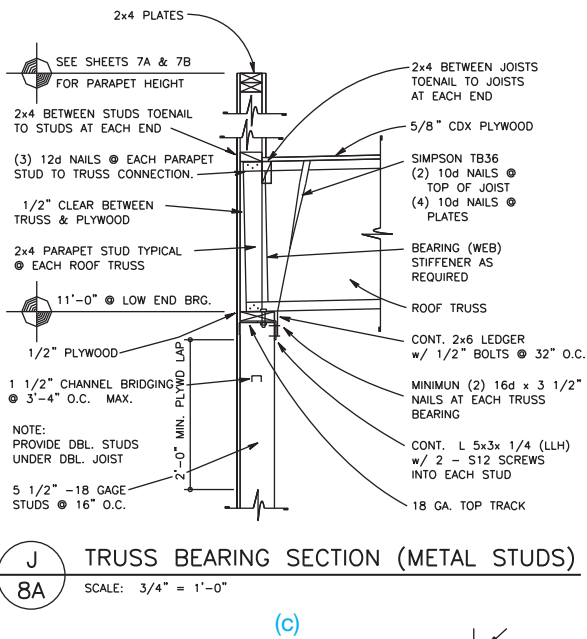
**FIGURE 22.68** Typical slab and footing details. © Cengage Learning 2012

### Exterior Elevations

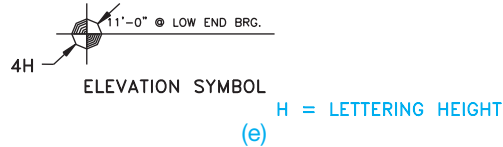
**Exterior elevations** are drawings that show the external appearance of the building. An elevation is drawn at each side



(a and b) 7-Eleven, Inc.

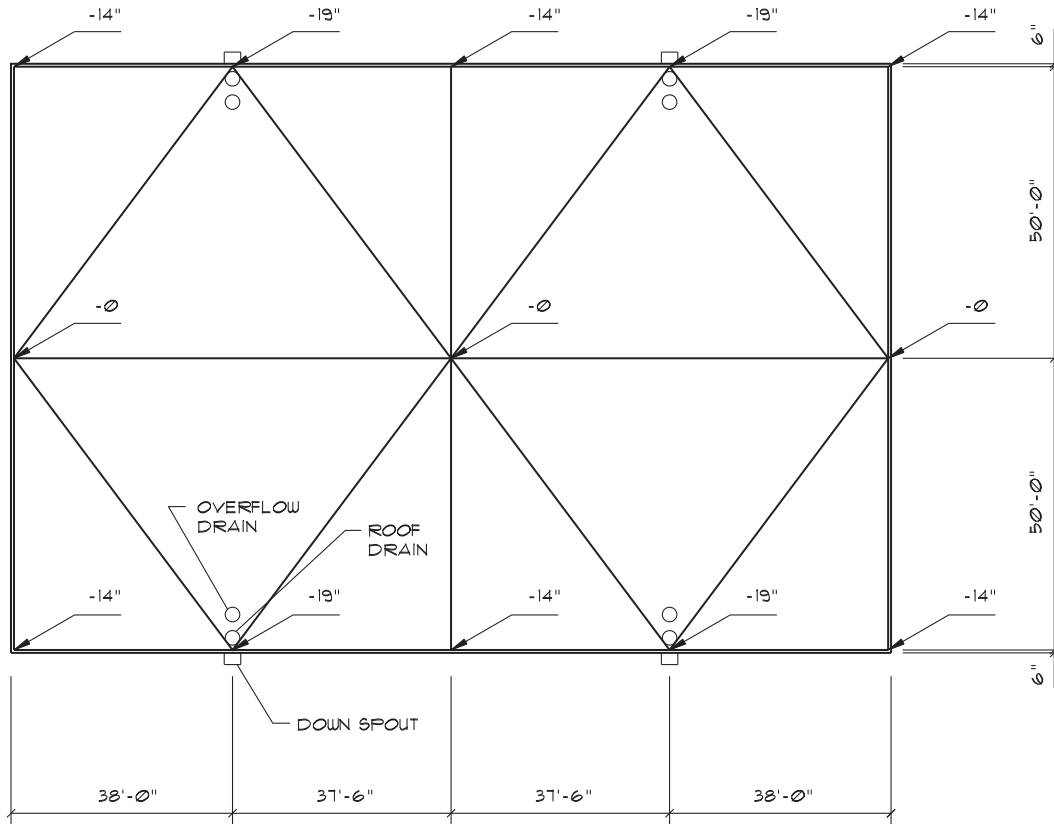


(c and d) Courtesy Wendy's International, Inc.



**FIGURE 22.69** Roof construction details. (a) Wall cap flashing detail. (b) Roof drain detail. (c) Truss bearing section. (d) Blocking and bracing detail. (e) Elevation symbol is used to designate the elevation of a specific location. The elevation is above a known zero elevation on the structure. © Cengage Learning 2012





ROOF DRAINAGE PLAN

SCALE: 1/16" = 1'-0"

GENERAL NOTES:

1. ROOF AND OVERFLOW DRAINS SHALL BE LARGE GENERAL PURPOSE TYPE W/ NON-FERROUS DOMES AND 4"Ø OUTLETS.
2. OVERFLOW DRAINS SHALL BE SET W/ INLET 2" ABOVE ROOF DRAIN INLET AND SHALL BE CONNECTED TO DRAINS LINES INDEPENDENT FROM ROOF DRAINS.
3. USE A 4"H X 7W SCUPPER W/5" NOMINAL (3 3/4 X 5) RECTANGULAR CORRUGATED DOWNSPOUT. PROVIDE A 6" X 9" CONDUCTOR HEAD @ TOP OF DOWNSPOUT.

© Cengage Learning 2012

FIGURE 22.70 Roof drainage plan.

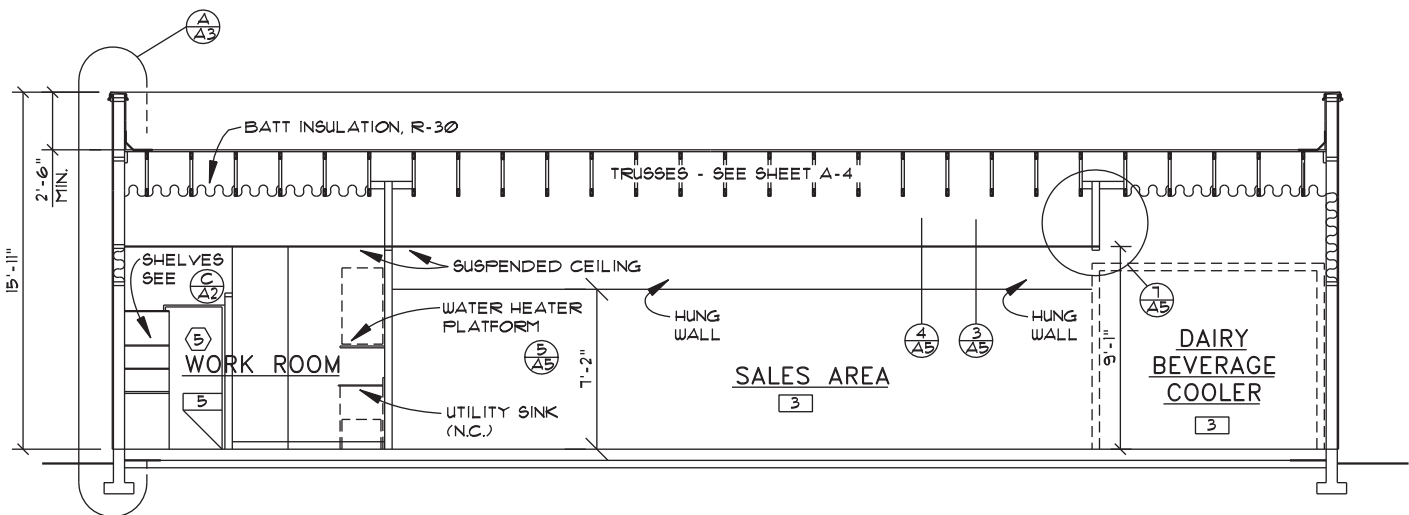
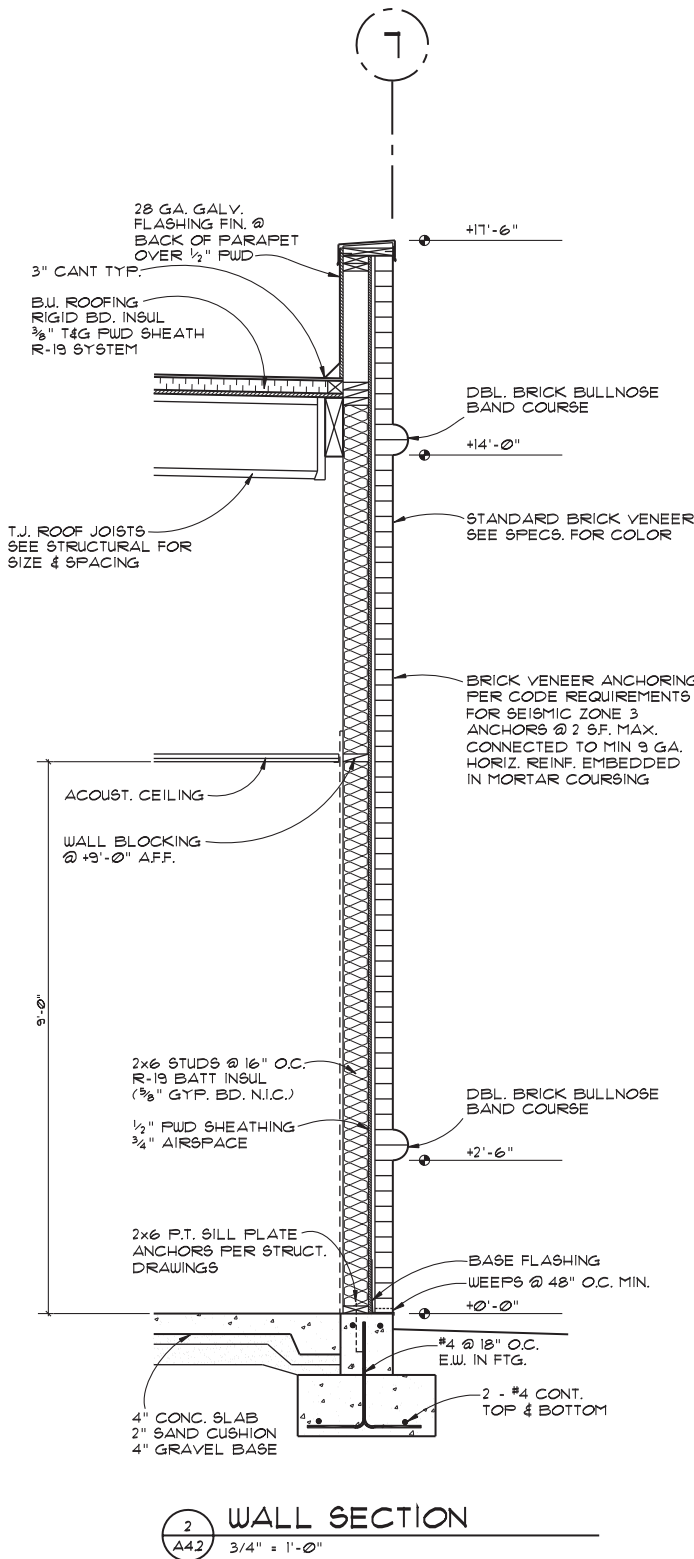


FIGURE 22.71 Typical building sections for commercial construction are often drawn at a small scale to show major types of construction with specific information shown in details. Courtesy 7-Eleven, Inc.



**FIGURE 22.72** Partial sections are used to clarify construction information through various portions of the structure. *Courtesy Ankrum Moisan Architects*

of the building to show the relationship of the building to the final grade, the location of openings, wall heights, roof slopes, exterior building materials, and other exterior features. A front elevation is generally the main entry view and is drawn at a 1/4" = 1'-0" scale, depending on the size of the structure. Other elevations can be drawn at a smaller scale. The elevation scale depends on the size of the building, the amount of detail shown, and the sheet size used. Many companies prefer to draw all elevations at the same scale showing an equal amount of detail in all views. An elevation can be omitted if it is the same as another. When this happens, the elevation can be labeled as RIGHT AND LEFT ELEVATION. Elevations are also often labeled by compass orientation, such as SOUTH ELEVATION.

Elevations can be drawn showing a great deal of detail as shown in Figure 22.73. Often elevations for commercial buildings are drawn at a small scale representing very little detail as shown in Figure 22.74, page 981. In many situations, the drafter is required to draw interior elevations or details such as the interior finish elevation detail for Farrell's as shown in Figure 22.75. Interior elevations are drawings that show the inside appearance of specific characteristics such as cabinets, architectural details, and other inside features that need to be represented for construction.

**Panel Plan, Elevations, and Wall Details**

The **panel plan** is used in tilt-up construction to show the location of the panels as shown in Figure 22.76.

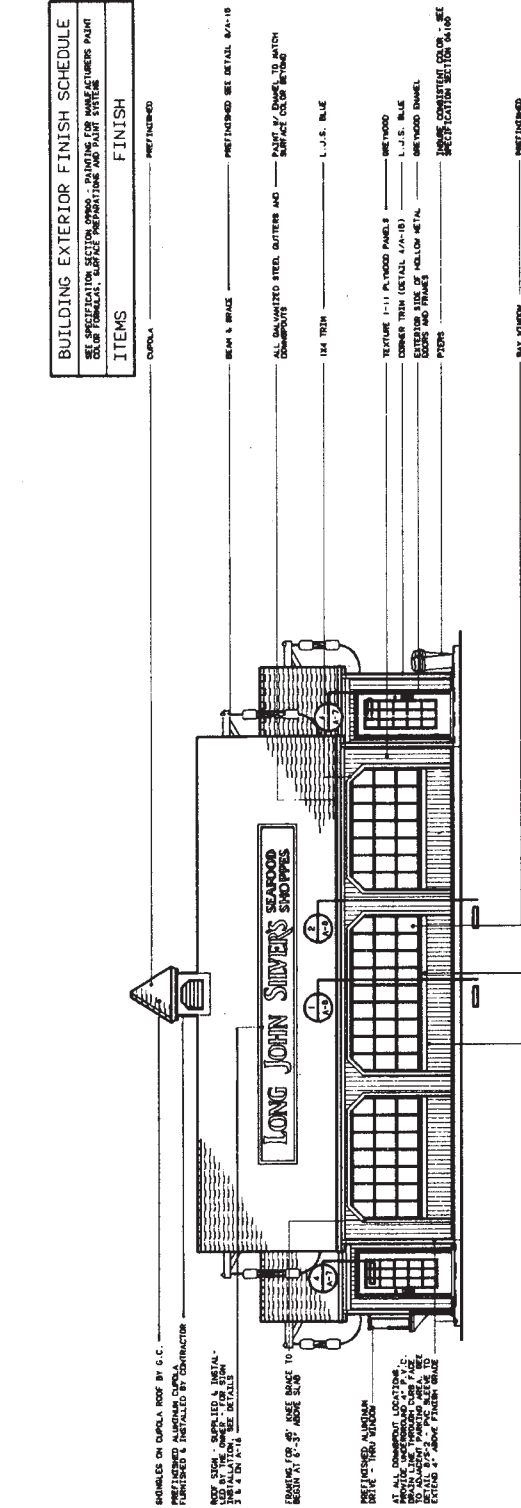
**Panel elevations** are used when the exterior elevations do not clearly show information about items located on or in the walls. Similar to exterior elevations, the panel elevations show door locations and reinforcing within walls and around openings. Dimensions associated with panel elevations provide both horizontal and vertical dimensions for openings and other features (see Figure 22.77).

**Wall details** are used to show the connection points of the concrete panels used in tilt-up construction and connection details at the walls for other types of structures (see Figure 22.78).

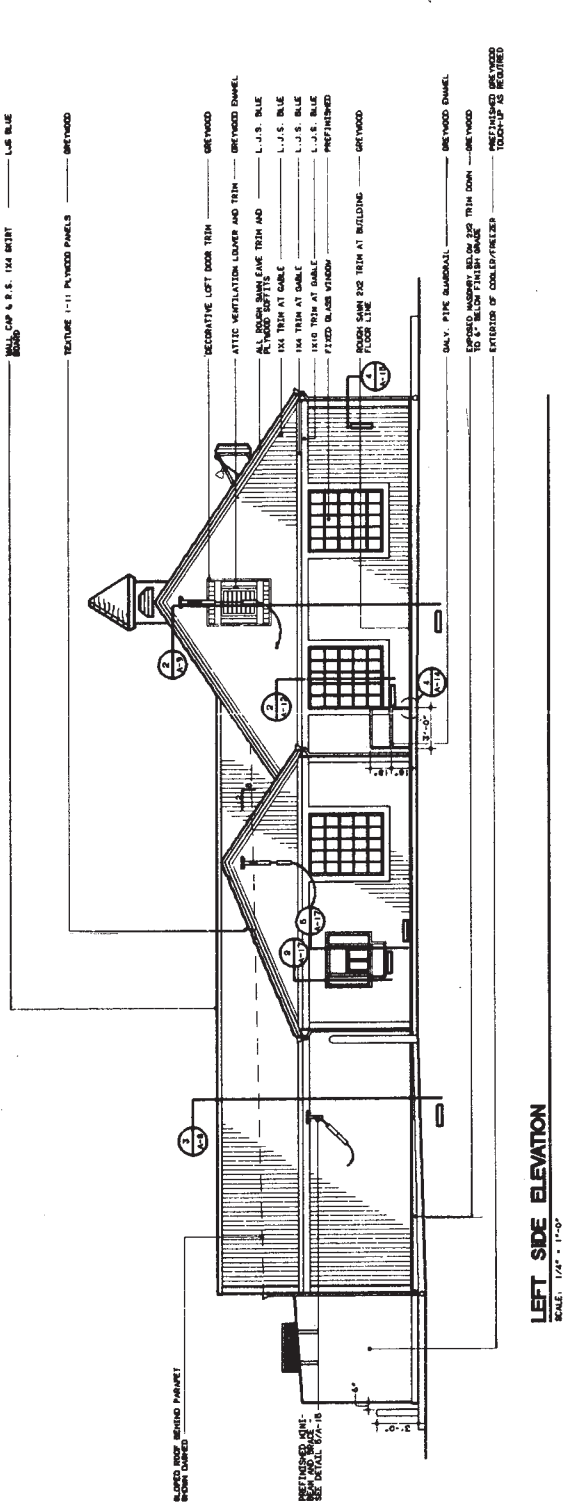
**DRAWING REVISIONS**

**Drawing revisions** are common in the architectural, structural, and construction industry. Revisions can be caused for a number of reasons. For example, changes requested by the owner, job-site corrections, correcting errors, or code changes. Changes are done in a formal manner by submitting an **addendum** to the contract, which is a written notification of the change or changes and is accompanied by a drawing that represents the change.

PROJ. NO.	STD22.
DATE	(blank)
NO.	(blank)
REV.	(blank)
BY	(blank)
CHECKED BY	(blank)
DATE	(blank)
SCALE	(blank)
TITLE	BASE SHEETS
LANDSC.	(blank)
ARCHITECTURAL	(blank)
STRUCT.	(blank)
EQUIPMENT	(blank)
H.V.A.C.	(blank)
PLUMBING	(blank)
ELECTRICAL	(blank)



**FRONT ELEVATION**  
SCALE: 1/4" = 1'-0"



**LEFT SIDE ELEVATION**  
SCALE: 1/4" = 1'-0"

**LONG JOHN SILVER'S**  
SEAFOOD SHOPPES

1001 SEAFOOD DRIVE  
1500 15th Street, S.E.  
Atlanta, GA 30316

1001 SEAFOOD DRIVE  
1500 15th Street, S.E.  
Atlanta, GA 30316

FOR ILLUSTRATION ONLY  
NOT FOR CONSTRUCTION

**A-5**

**BUILDING EXTERIOR FINISH SCHEDULE**

SEE SPECIFICATION SECTION 05100 - PAINTING FOR MANUFACTURERS PAINT COLOR FORMULAS, SURFACE PREPARATIONS AND PAINT SYSTEMS

ITEMS	FINISH
CUPOLA	REFINISHED
BEAM & BRACE	REFINISHED SEE DETAIL 8/7-18
ALL GALVANIZED STEEL, GUTTERS AND DOWNSPUTS	PAINT 1/2" DANDEL TO MATCH SURFACE COLOR RETURN
1X4 TRIM	L.J.S. BLUE
TEXTURE 1-11 PLYWOOD PANELS	GREYWOOD
CORNER TRIM (DETAIL 4/7-18)	L.J.S. BLUE
SUBSTITUTION SIZE OF HOLLOW METAL PANELS	GREYWOOD DANDEL
PIPES	PAINT CONSISTENT COLOR - SEE SPECIFICATION SECTION 04100
RAY WINDOW	REFINISHED
JAMBLED AND GILL PIECE FOR BAY WINDOW	GREYWOOD
TRIM ABOVE AND BOTTOM OF BAY WINDOW	GREYWOOD
HALL CAP & S.S. 1X4 BRIST BRICK	L.J.S. BLUE
TEXTURE 1-11 PLYWOOD PANELS	GREYWOOD

**FIGURE 22.73** CADD elevations of Long John Silver's Seafood Shoppes. Courtesy Jerrico Inc.

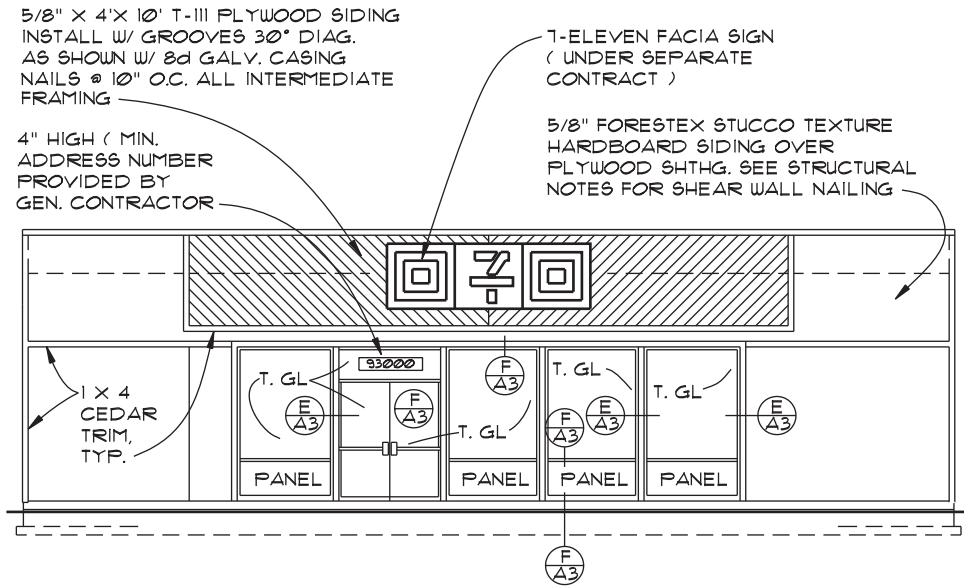


FIGURE 22.74 Elevations for commercial structures, such as this 7-11 store, often require little detail and may be drawn at a small scale.

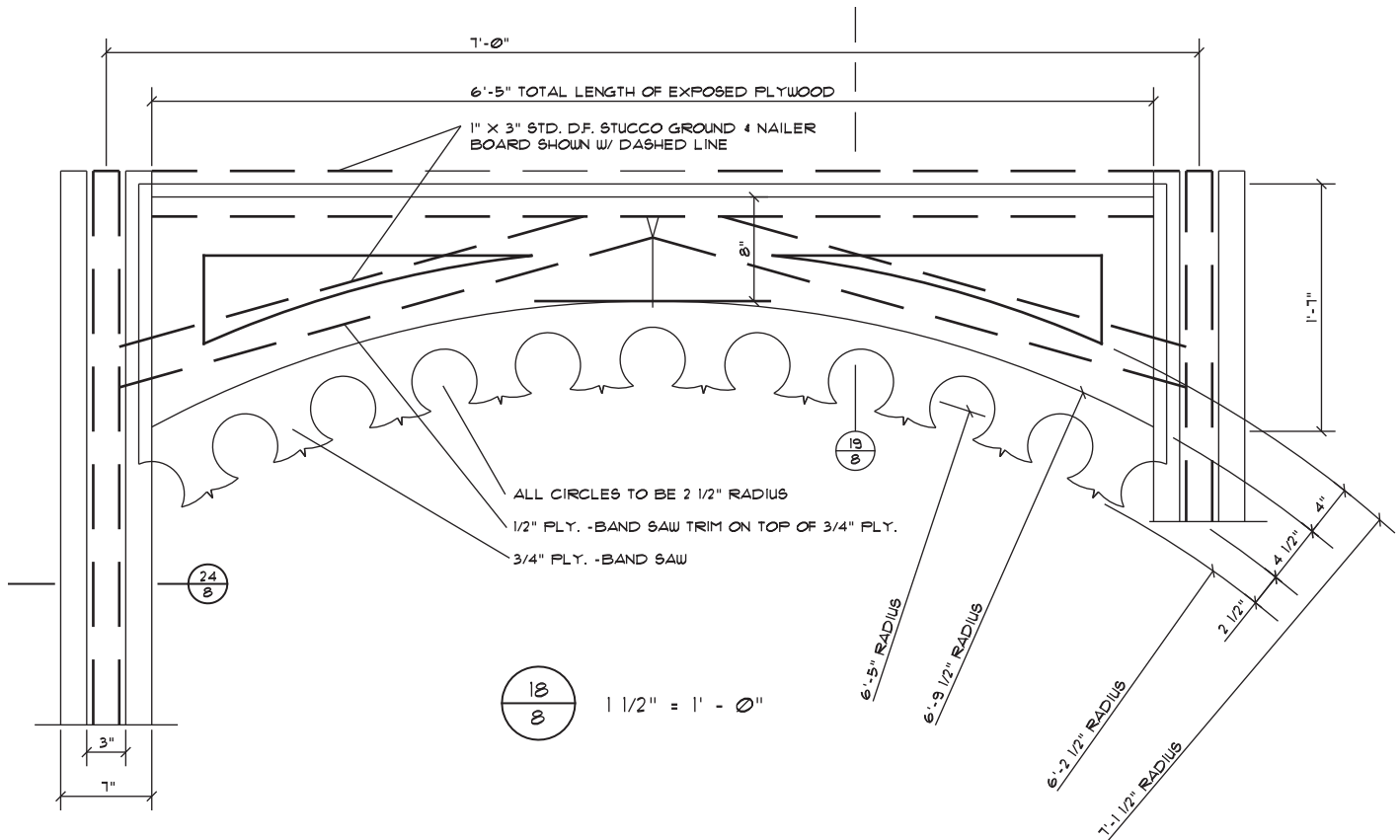


FIGURE 22.75 In addition to structural details, the drafter may be required to draw interior elevations and details such as this finish detail for Farrell's Restaurant.

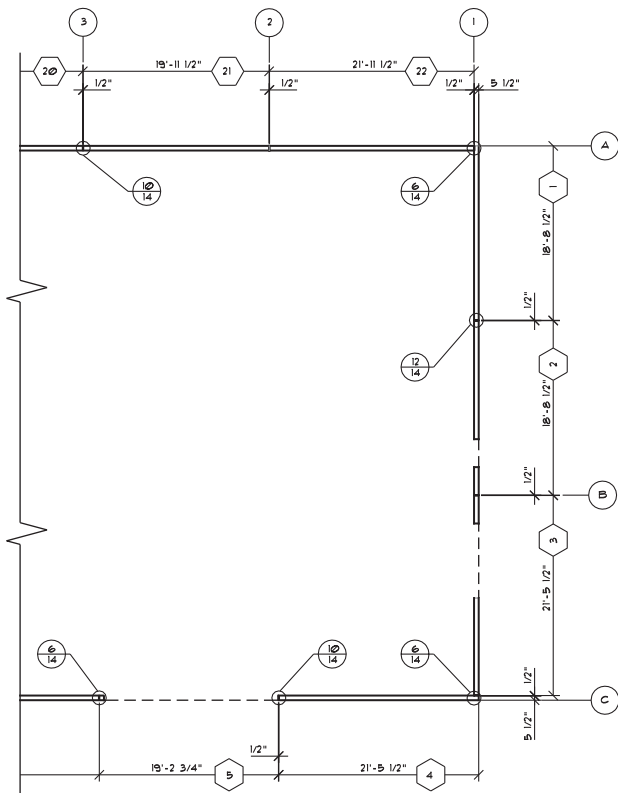


FIGURE 22.76 Tilt-up panel plan.

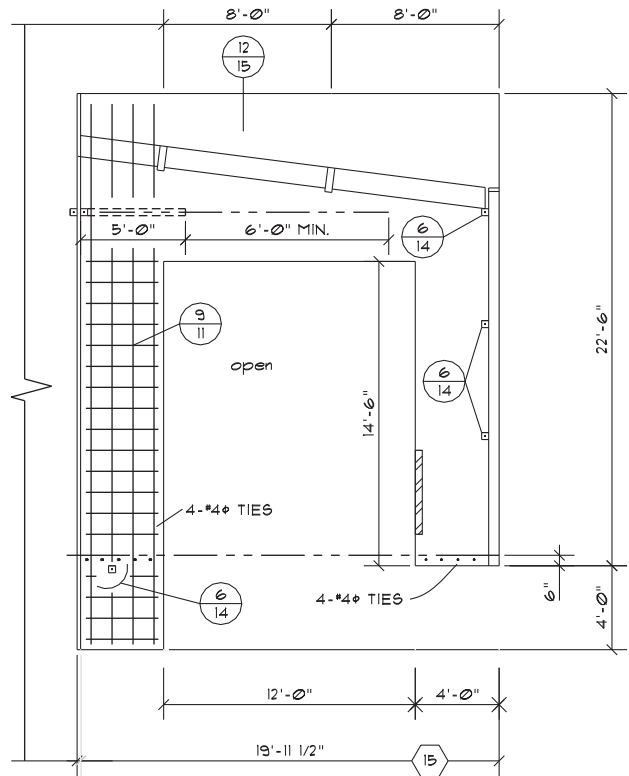
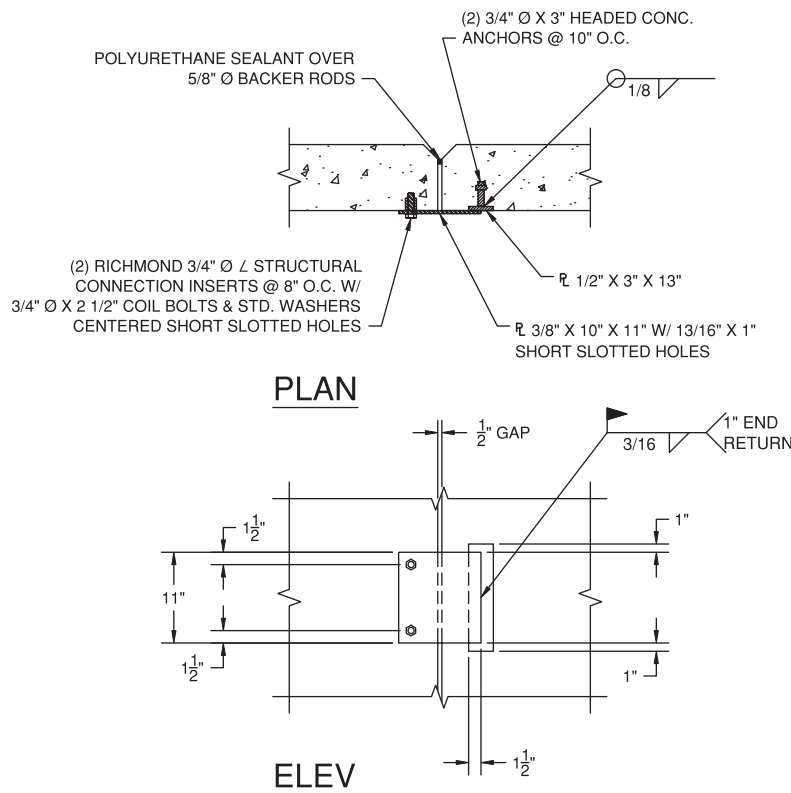


FIGURE 22.77 Steel and opening locations specified in precast panel elevation.



1 PANEL CONNECTOR  
3 SCALE 1" = 1'-0"

FIGURE 22.78 A typical wall connection detail.

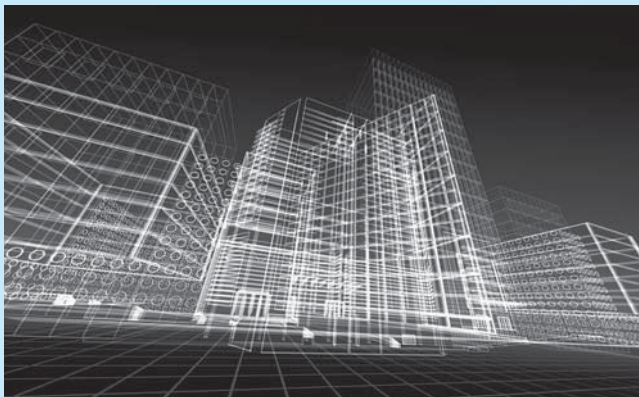
## STRUCTURAL DRAFTING

The procedure for preparing structural drawings works especially well with CADD. The floor plan is used as a base drawing on which each of the other plan views is drawn. Layers are one CADD tool that offers a fast and effective way to manage drawing content. Layers significantly aid the separation and development of unique drawings—for example, draw all floor plan objects using floor plan layers such as A-WALL for architectural walls and A-DOOR for architectural doors. To prepare the foundation plan, reuse floor plan layers that are still valid, hide floor plan layers that are not required for the foundation plan, and use unique foundation plan layers such as S-FNDN to create structural foundation plan objects. By using appropriate layering techniques, you can create unique views using a single drawing.

There is structural CADD software that quickly and accurately draws structural steel shapes to exact

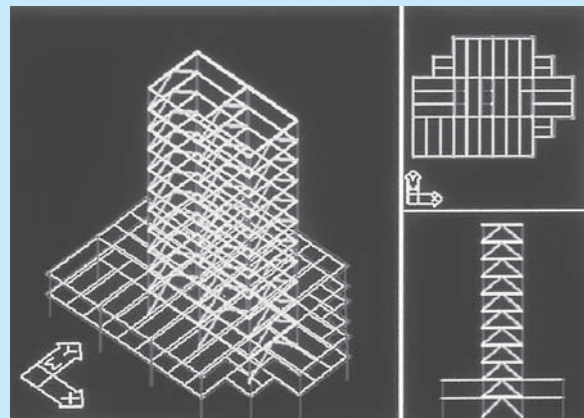
specifications in plan, section, or elevation views. These structural steel packages also provide for beam details, integrating cutouts, framing angles, hole groups, welded or bolted connections, and complete dimensioning. An advantage is the capability of such programs to automatically perform tedious standards specification sizing and calculations. You do not have to spend time dimensioning hole patterns, because the program draws bolt or rivet hole patterns to your specifications, automatically displaying them on center dimensions, hole diameters, and flange thicknesses. When framing angles are used, the package automatically draws, sizes, positions, dimensions, and notes the angle specifications along with bolt holes and dimensions. These CADD structural packages are often available with a variety of template menus and symbol libraries. Detail views and symbology are often available from manufacturers of structural systems and components.

Structural engineering software programs are available that integrate structural analysis, design, and drafting. A 3-D model is made during the design and drafting process as shown in Figure 22.79. The model can be updated



**FIGURE 22.79** A 3-D model is made during the CADD design and drafting process. *dinn/Vetta/Getty Images*

at any time from new design information. The model can be used to automatically create framing plans and elevations as shown in Figure 22.80. The software package



**FIGURE 22.80** Creating framing plans and elevations with the 3-D model. *Courtesy Computers and Structures, Inc.*

(Continued)

also creates construction details for a variety of materials. The construction details can be drawn at any scale and stored for later use. Parametric design of welding symbols and specifications allows the designer to change a variable and automatically update the entire drawing. Detail models as shown in Figure 22.81 can be converted to traditional 2-D views complete with dimensions and specifications.

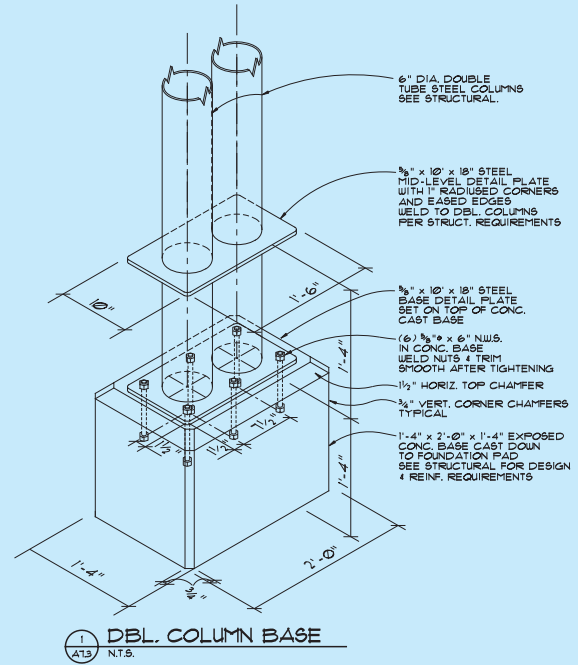


FIGURE 22.81 A 3-D CADD model of a structural detail.

Courtesy Ankrum Moisan Architects

## Revision Clouds

A **revision cloud** is placed around the area that is changed. The revision cloud is a cloudlike circle around the change as shown in Figure 22.82. CADD programs that are commonly used for architectural and structural drafting have commands that allow you to easily draw the revision cloud. There is also a triangle

with a revision number inside that is placed next to the revision cloud or along the revision cloud line as shown in Figure 22.83. The triangle is commonly called a **delta** or **flag note**. The number is then correlated to a revision note placed somewhere on the drawing or in the title block as shown in Figure 22.84. Each company has a desired location for revision notes, although common places are in the corners of the drawing, in a revision

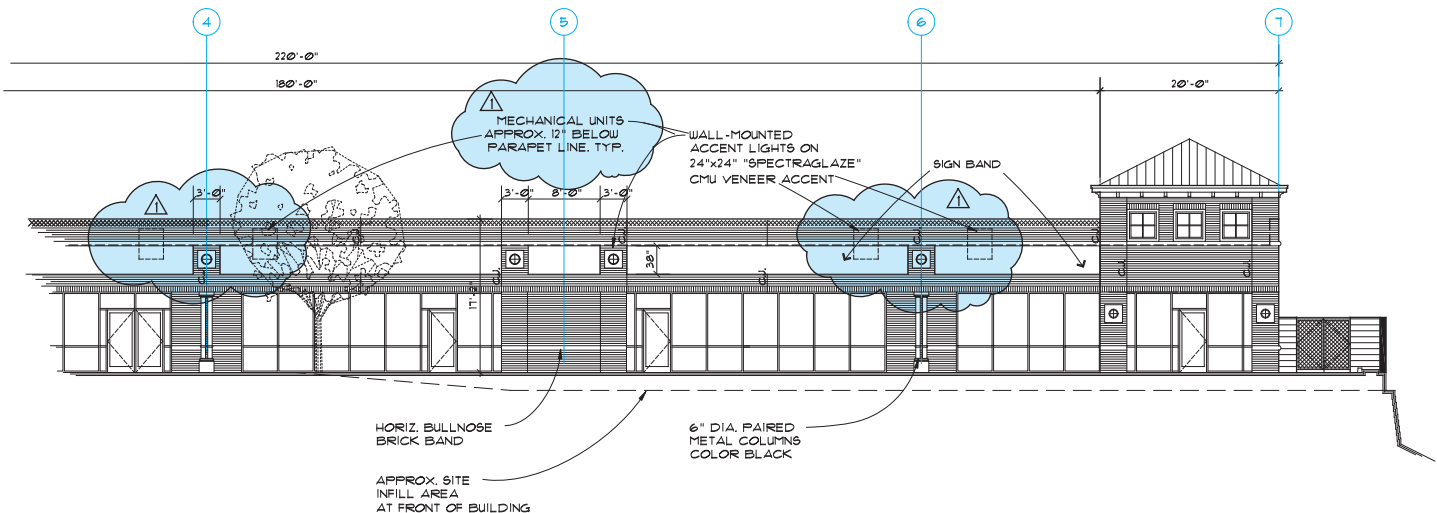
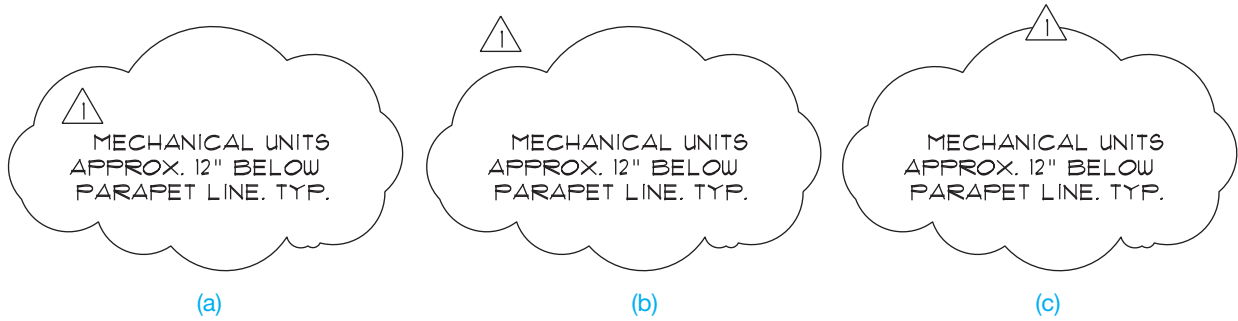


FIGURE 22.82 A typical revision cloud and delta reference. Courtesy Ankrum Moisan Architects



**FIGURE 22.83** Placement of the delta reference with the revision cloud. (a) Delta inside of the revision cloud. (b) Delta outside of the revision cloud. (c) Delta inserted in the revision cloud line. © Cengage Learning 2012

CedarOak EXTERIOR
REVISIONS
REVISION 1 1/10/01
DATE 03/07/01
FILE A3-1
JOB 966600
DWN.KC   CHK ME
<h1 style="margin: 0;">A3.1</h1>
OF SHEETS

SCALE: 1" = 8'-0"

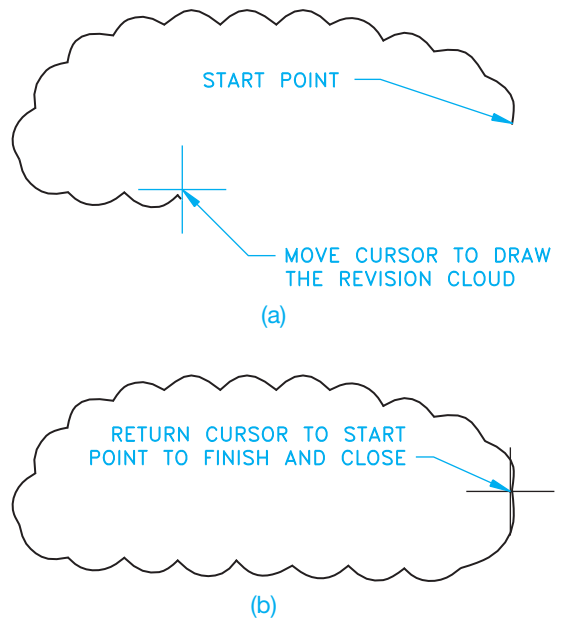
Courtesy Ankrum Moisan Architects

**FIGURE 22.84** Revision reference in the title block. The specific information about the revision is found in the job file.

block or table, or in the title block. This practice is not as clearly defined as in ASME standard drawings. The note is used to explain the change. If a reference is given in the title block, then detailed information about the revision is normally provided in the revision document that is filed with the project information. The revision document is typically filled out and filed for reference, because changes can cause increased costs in a project.

### CADD Application

It is easy to draw revision clouds with CADD. For example, AutoCAD has a REVCLLOUD command that allows you to specify the revision cloud arc length and draw a revision cloud around any desired area. The command works by picking a start point and then moving the cursor in the desired direction to create the revision cloud as shown in Figure 22.85a. Create the revision cloud in a pattern around the desired area while moving the cursor back toward the start point. Press the pick button when the cursor is back at the start point to complete the revision cloud as shown in Figure 22.85b.



**FIGURE 22.85** The AutoCAD REVCLLOUD command automatically draws arc segments along the path that you move the cursor. (a) Starting and continuing the revision cloud. (b) The complete revision cloud.

© Cengage Learning 2012



## GENERAL CONSTRUCTION SPECIFICATIONS

Specifications are written documents that describe in detail the requirements for products, materials, and workmanship on which the construction project is based. A specification is an exact statement describing the characteristics of a particular aspect of the project. Specifications communicate information about required products to be used in construction, as a basis for competitive construction bidding, and to measure compliance with contracts. Proprietary product, method, and end result are performance specifications methods commonly used in the construction industry.

**Proprietary product specification** provides specific product names and models for desired applications. When this type of specification is used, a named product can be followed by or equivalent, which allows for equal alternatives and helps promote competition in providing the product. Proprietary product specifications can limit competition, increase cost, and decrease flexibility.

**Method specifications** outline material selection and construction operation process to be followed in providing construction materials and practices. Method specifications provide the final desired structure, such as the concrete thickness and strength, or the lumber dimensions, spacing, species, and grade. Method specifications allow for more flexibility, but the owner is responsible for the performance.

**End-result specifications** provide final characteristics of the products and methods used in construction, and the contractor can use a desired method for meeting the requirements. End-result specifications often provide minimum and maximum as a range of acceptable completion. For example, underconcrete slab gravel might be specified between 4 and 8 in. thick with specific compaction given. End-result specifications can use statistical methods to estimate overall material quality based on a limited number of random samples. End-result specifications place construction quality on the contractor by defining the desired final product. Such specifications can allow the contractor freedom in achieving that final product, which can lead to innovation, efficiency, and lower costs.

## SPECIFICATIONS FOR COMMERCIAL CONSTRUCTION

Specifications for **commercial construction** projects are often more complex and comprehensive than the documents for residential construction. Commercial project specifications can provide very detailed instructions for each phase of construction. Specifications can establish time schedules for the completion of the project. Also, in certain situations, the specifications include inspections in conjunction with or in addition to those required by a local jurisdiction. Construction specifications often follow the guidelines of the individual architect or

engineering firm, although a common format has been established: *MasterFormat™: Master List of Numbers and Titles for the Construction Industry*, which is published by the Construction Specifications Institute (CSI) and the Construction Specifications Canada (CSC).

The Construction Specifications Institute (CSI)  
99 Canal Center Plaza, Suite 300  
Alexandria, VA 22314 (www.csinet.org)  
Construction Specifications Canada (CSC)  
120 Carlton Street, Suite 312  
Toronto, ON, M5A 4K2 (www.csc-dcc.ca)

The MasterFormat numbers and titles offer a master list of numbers and subject titles for organizing information about construction work results, requirements, products, and activities into a standard sequence. Construction projects use many different delivery methods, products, and installation methods. Successful completion of projects requires effective communication among the people involved. Information retrieval is nearly impossible without a standard filing system familiar to each user. The MasterFormat numbers and titles document facilitate standard filing and retrieval schemes throughout the construction industry. MasterFormat is suitable for use in project manuals, for organizing cost data, for reference keynotes on drawings, for filing product information and other technical data, for identifying drawing objects, and for presenting construction market data.

Each MasterFormat number and title defines a *section*, which is arranged in *levels*, depending on its depth of coverage. The broadest collections of related construction products and activities are level one titles, otherwise known as *divisions*. Each division in the *MasterFormat: Master List of Numbers and Titles for the Construction Industry*, 2004 edition, is made up of level two, level three, and occasionally level four numbers and titles assigned by MasterFormat, each of which defines a gradually more detailed area of work results to be specified. **Work results** are traditional construction practices that typically result from an application of skills to construction products or resources.

The *MasterFormat* numbers are established using a six-digit system. The following is an example showing how the list of numbers and titles are used in the numbering system:

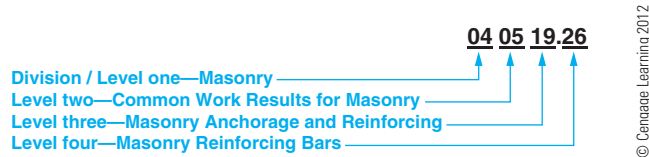
### Division 04—Masonry

The first two numbers—04 in this example—represent the division and are also called *level one*. The complete list of divisions are given in the next section of this textbook.

### 04 05 Common Work Results for Masonry

The second pair of numbers—05 in this example—is referred to as level two. In this case, Common Work Results for Masonry is a subcategory of Masonry.

### 04 05 19 Masonry Anchorage and Reinforcing



**FIGURE 22.86** Construction Specifications Institute (CSI) MasterFormat titles and numbering system.

The third pair of numbers—19 in this example—is called level three. In this case, Masonry Anchorage and Reinforcing is a subcategory of Common Work Results for Masonry.

04 05 19.26 Masonry Reinforcing Bars

Occasionally, level four numbers are provided, such as .26 in this example. When level four numbers are used, they follow level three numbers and are separated from level three numbers with a dot. Level four numbers are used when the amount of detail requires additional level of classification. In this case, Masonry Reinforcing Bars is a subcategory of Masonry Anchorage and Reinforcing.

An example of the six-digit numbering system with levels one through four is shown in Figure 22.86.

## MasterFormat Division Numbers and Titles

The MasterFormat has two main groups: (1) Procurement and Contracting Requirements and (2) Specifications. Procurement and Contracting Requirements are referred to as series zero because they begin with a 00 level one numbering system prefix. These documents are not specifications. They establish relationships, processes, and responsibilities for projects. The Specifications group contains the construction specifications subgroups and their related divisions. Some divisions are identified as reserved for future additions or specific user applications. The following is an outline of the divisions found in the two groups:

### PROCUREMENT AND CONTRACTING REQUIREMENTS GROUP

Division 00 Procurement and Contracting Requirements

### SPECIFICATIONS GROUP

#### General Requirements Subgroup

Division 01 General Requirements

#### Facility Construction Subgroup

Division 02 Existing Conditions

Division 03 Concrete

Division 04 Masonry

Division 05 Metals

Division 06 Wood, Plastics, and Composites

Division 07 Thermal and Moisture Protection

Division 08 Openings

Division 09 Finishes  
 Division 10 Specialties  
 Division 11 Equipment  
 Division 12 Furnishings  
 Division 13 Special Construction  
 Division 14 Conveying Equipment  
 Divisions 15 through 19 Reserved

#### Facility Services Subgroup

Division 20 Reserved  
 Division 21 Fire Suppression  
 Division 22 Plumbing  
 Division 23 Heating, Ventilating, and Air-Conditioning  
 Division 24 Reserved  
 Division 25 Integrated Automation  
 Division 26 Electrical  
 Division 27 Communications  
 Division 28 Electronic Safety and Security  
 Division 29 Reserved

#### Site and Infrastructure Subgroup

Division 30 Reserved  
 Division 31 Earthwork  
 Division 32 Exterior Improvements  
 Division 33 Utilities  
 Division 34 Transportation  
 Division 35 Waterway and Marine Construction  
 Divisions 36 through 39 Reserved

#### Process Equipment Subgroup

Division 40 Process Integration  
 Division 41 Material Processing and Handling Equipment  
 Division 42 Process Heating, Cooling, and Drying Equipment  
 Division 43 Process Gas and Liquid Handling, Purification, and Storage Equipment  
 Division 44 Pollution Control Equipment  
 Division 45 Industry-Specific Manufacturing Equipment  
 Divisions 46 and 47 Reserved  
 Division 48 Electrical Power Generation  
 Division 49 Reserved

## The UniFormat Uniform Classification System

The UniFormat is a uniform classification system for organizing preliminary construction information into a standard order or sequence on the basis of functional elements. **Functional elements**, also referred to as **systems or assemblies**, are common major components in buildings that perform a known function regardless of the design specification, construction method, or materials used. The use of UniFormat can provide consistent comparable data across an entire building life cycle. **Building life cycle** refers to the observation and examination of a building over the course of its entire life. The life cycle of a building considers everything about the building from design, commissioning, operation, and decommissioning.

The purpose of UniFormat is to achieve consistency in economic evaluation of projects, enhance reporting of design program information, and promote consistency in filing information for facility management, drawing details, and construction market data. UniFormat classifies information into nine level 1 categories that can be used to arrange brief project descriptions and preliminary cost information. The first level 1 category is Project Description, which includes information about the project, through cost estimating and funding. The last eight level 1 categories are referred to as Construction Systems and Assemblies, which include the construction applications and practices, such as foundation, roofing, exteriors, electrical and plumbing. Each of the Construction Systems and Assembly categories are identified with a letter and title as follows:

- A—Substructure
- B—Shell
- C—Interiors
- D—Services
- E—Equipment and Finishings
- F—Special Construction and Demolition
- G—Building Sitework
- Z—General

UniFormat has a numbering system that divides each level 1 category into levels 2, 3, 4, and 5 titles with set alphanumeric labels. The following is an example showing the first three levels of a UniFormat alphanumeric system for a specific category:

- Level 1: D Services
- Level 2: D20 Plumbing
- Level 3: D2010 Plumbing Fixtures

## BASIC DRAWING LAYOUT STEPS

The following gives basic steps that you can use when laying out a set of structural drawings. Not all elements of a set of drawings are demonstrated, but the steps used in the examples can be applied to any of the components in the set of working drawings.

### Laying Out the Plan Views

The structural plan views are normally the drawings that begin the complete set. These include the types of drawings already discussed, such as the floor plan, foundation plan, and roof framing plan. After the plan views have been drawn, the sections and details can be properly correlated.

#### The Floor Plan: Step 1

Begin by laying out the floor plan at a scale that provides the clearest representation on the sheet size to be used. Normally, a scale range of  $1/8" = 1'-0"$  to  $1/4" = 1'-0"$  (1:100–1:50 metric) is used. Draw the outline of the building, leaving enough space for dimensions and notes as shown in Figure 22.87.

#### The Floor Plan: Step 2

Draw all internal walls, partitions, posts, and fixtures. Draw all dimensions. Structural drafting normally uses aligned dimensioning with the dimension numeral placed above the

## GREEN TECHNOLOGY APPLICATION

### THE CONSTRUCTION SPECIFICATIONS INSTITUTE GREENFORMAT™

The Construction Specifications Institute has established *GreenFormat™: The Construction Product Sustainability Information Reporting Guide*. GreenFormat is a new CSI format that allows manufacturers to accurately report the sustainability measuring properties of their products. It also provides designers, contractors, and building operators with basic information to help meet green requirements. When using GreenFormat, construction product manufacturers complete an online GreenFormat reporting questionnaire that collects the sustainable information about their product. Data from the questionnaires is displayed in a standardized style designed to ease sustainable-design decision making. Access to

the GreenFormat report and the resulting data is provided through [www.greenformat.com](http://www.greenformat.com).

Those who use the Web site are able to print reports on specific products based on their questions within the database. Sustainable information reported in GreenFormat is grouped into categories, each containing individual topics and questions about product sustainability. The categories are organized with topics more likely to be important to design decisions first. This flexible structure can adapt to anticipated changes in the industry. As sustainability issues evolve, new topics and questions are added in the appropriate category, and existing topics and questions that become obsolete or change are dropped if necessary. The structure can be applied to all construction products and product categories. Go to [www.greenformat.com](http://www.greenformat.com) to see the categories and their contents and to view additional information about GreenFormat.

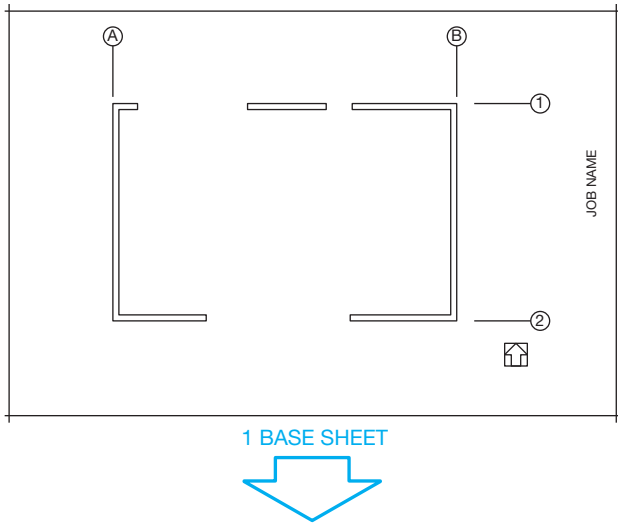


FIGURE 22.87 Step 1: Outline the floor plan.

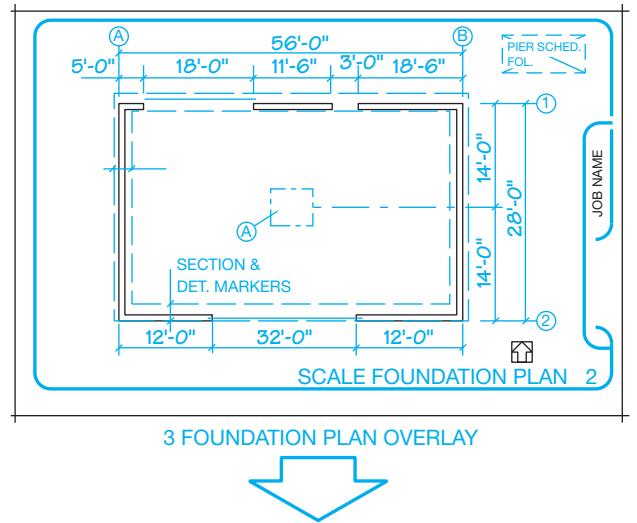


FIGURE 22.89 Step 2: Lay out the foundation with the floor plan as a guide.

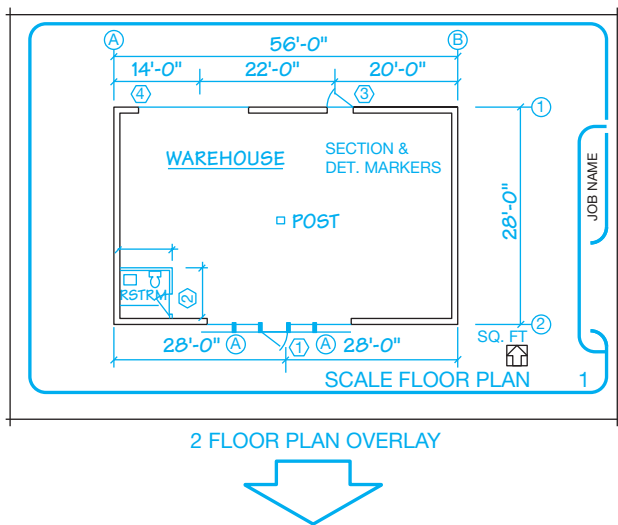


FIGURE 22.88 Draw all interior features and dimensions and add notes and title to complete the floor plan.

dimension line and slashes placed where the dimension and extension lines meet as shown in Figure 22.88. Finally, notes, symbols, and titles are added to complete the drawing.

### The Foundation Plan: Step 1

After the floor plan has been drawn, turn off or freeze the layers that are not used to lay out the foundation, such as partitions and fixtures. Leave the perimeter wall, bearing wall, and post layers turned on. The floor plan makes an excellent guide for the other plans because it is the base for all other construction.

### The Foundation Plan: Step 2

Begin by drawing the foundation walls and footings. Next, add all dimensions, notes, and symbols. Finally, letter the title and scale as shown in Figure 22.89.

### The Roof Framing Plan: Step 3

The layout of the roof framing plan works in much the same way as the foundation plan. Again, use the floor plan as a basis for the roof plan drawing. This gives you all of the layout features to quickly begin the new drawing. First, draw beams and purlins. Second, completely dimension the drawing and add all necessary notes and symbols. Finally, add all schedules and titles as shown in Figure 22.90.

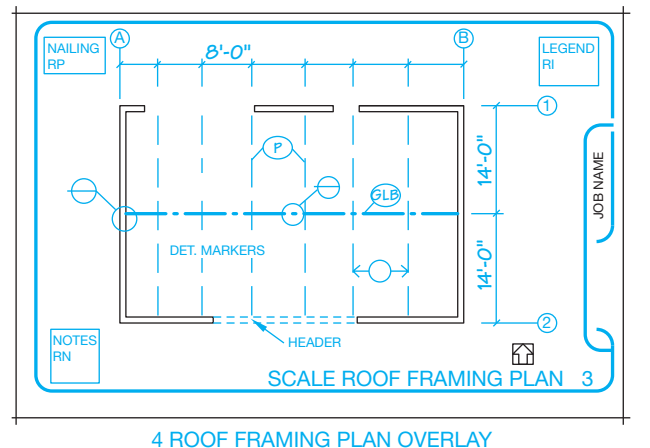


FIGURE 22.90 Step 3: Lay out the roof framing plan with the floor plan as a guide.

## Laying Out the Sections and Details

Cutting-plane lines and detail markers are placed on the plan views and correlated to section views and details placed on the same sheet as the plan views or on different sheets.

### Drawing Details: Step 1

The detail drawings can be placed with the plan views or on separate sheets. In either case, the details and sections must be clearly correlated to the plans. The scale of the detail drawings depends on the size and complexity of the structure to be drawn. Select a scale that clearly shows all construction details without oversizing the drawing, which can waste space and drawing time. Common scales for detail drawings range from  $1/2" = 1'-0"$  to  $3" = 1'-0"$  (1:20–1:5 metric). All the details can be the same scale or the scale can change, depending on the complexity of the drawing. In many cases, it is necessary to arrange many details on one sheet or in an area on a sheet. Do this by laying out the details, beginning at the top-left corner of the working area. Proceed with additional details placed in rows from left to right. The engineering sketch in Figure 22.2a, page 929, is used as a guide for the following layout.

Start the detail drawing by blocking out the major components of the structure. As you can see in the engineer's sketch, the beam on the left is 24" high and the beam on the right is 16" (400 mm) high. This makes the maximum beam height 24" (600 mm). If you add another 12" (300 mm) for the post and 12 more inches for the notes at a scale of  $1" = 1'-0"$  (1:10 metric), then you need a total drawing height of 48" (1200 mm) or an actual height of 4" (100 mm) at the selected scale. The width of the detail is up to you. All you need is enough space to show all of the construction members. So a width of about 4" should work. Start the detail layout as shown in Figure 22.91.

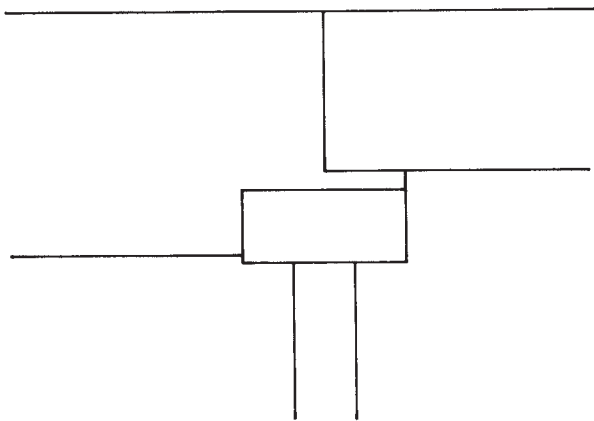


FIGURE 22.91 Step 1: Block out components of the detail.

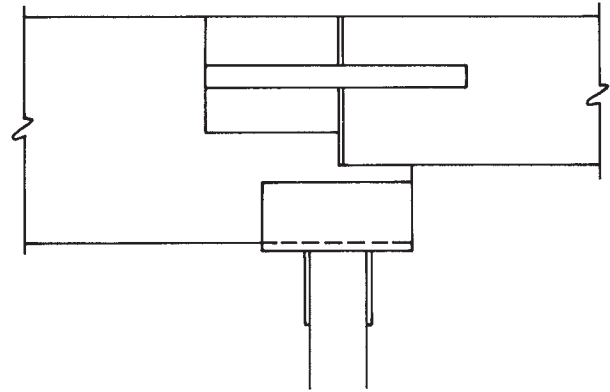


FIGURE 22.92 Step 2: Draw all construction members.

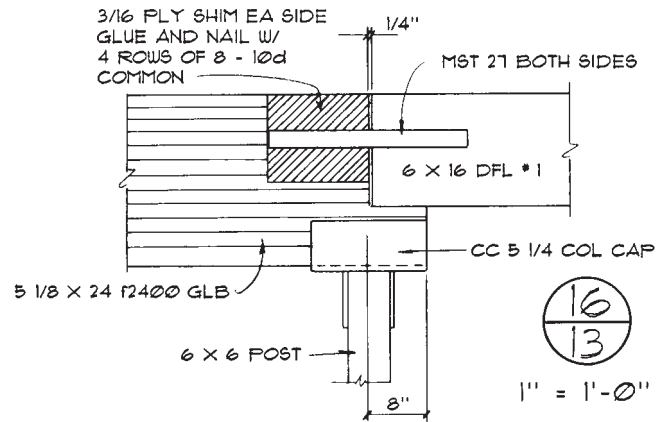


FIGURE 22.93 Step 3: The completed detail drawing is used to show the information of the engineer's calculation and sketch shown in Figure 22.2a.

### Drawing Details: Step 2

Proceed by drawing the construction members to scale. Refer to a vendor's catalog as shown in Figure 22.40, (page 958), to determine the actual sizes of the prefabricated connectors. Continue the detail layout as shown in Figure 22.92.

### Drawing Details: Step 3

Place all dimensions and notes on the drawing, followed by the title and scale, or the detail identification symbol and scale as shown in Figure 22.93.

**PICTORIAL DRAWINGS**

Pictorial drawings such as isometrics are sometimes used in the set of structural drawings when it is necessary to represent something more clearly than in a two-dimensional drawing. Pictorial drawings are not required, but they are done when

there is a need to aid in the visualization of specific construction applications. Figure 22.94 shows the use of pictorial drawings. Chapter 14, *Pictorial Drawings and Technical Illustrations*, covers pictorial drawings in detail.

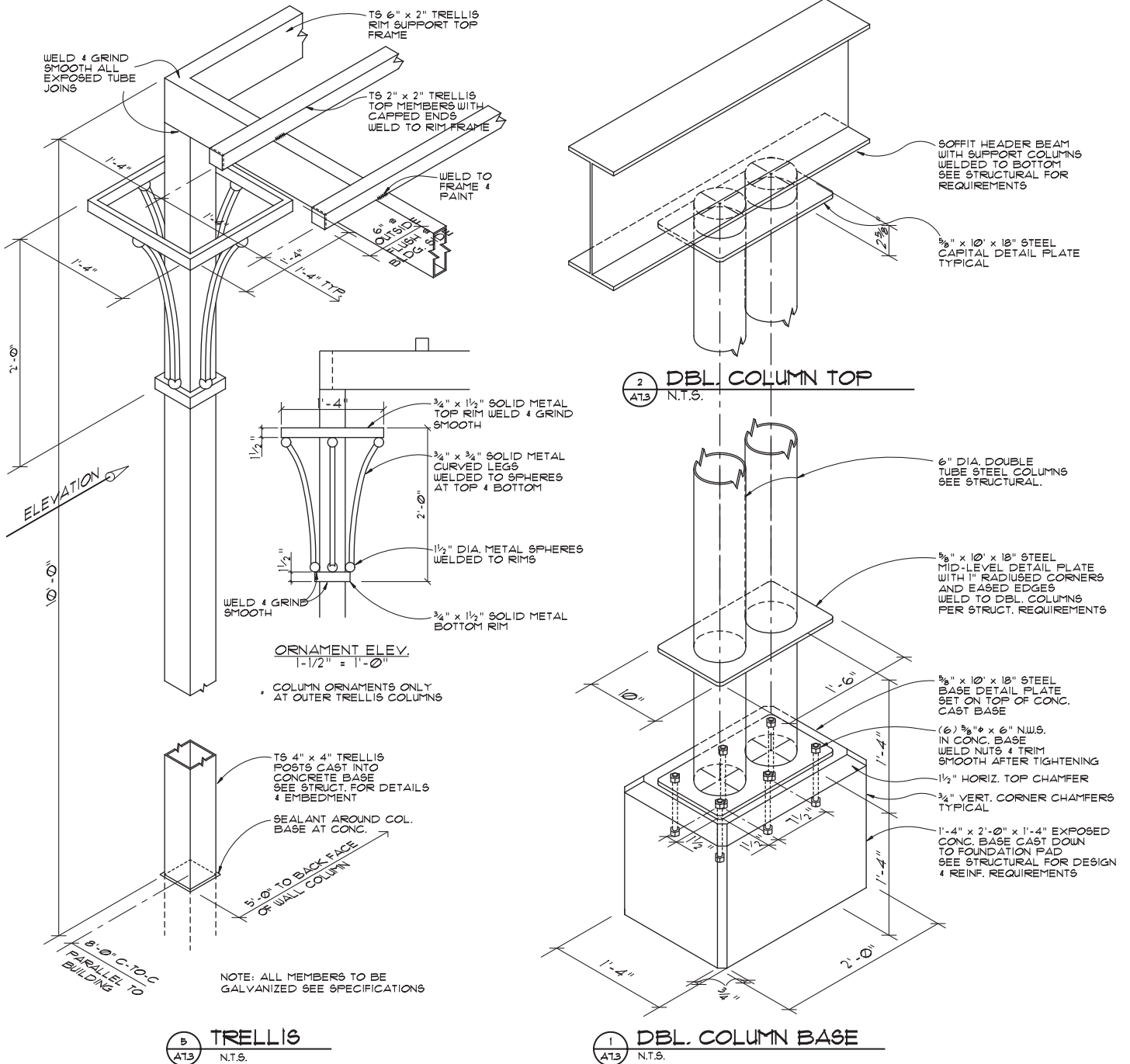


FIGURE 22.94 Pictorial detail drawings. Courtesy Ankrom Moisan Architects

## GREEN TECHNOLOGY APPLICATION

### SUSTAINABLE-DESIGN OPPORTUNITY

According to the U.S. Green Building Council ([www.documents.dgs.ca.gov/dgs/pio/facts/LA%20workshop/climate.pdf](http://www.documents.dgs.ca.gov/dgs/pio/facts/LA%20workshop/climate.pdf)), buildings alone account for a sizable amount of global greenhouse gas emissions, representing 39% of CO<sub>2</sub> emissions in the United States. This is primarily because of energy use, with buildings consuming 76% of all power plant-generated electricity, according to the U.S. Energy Information Administration ([www.architecture2030.org/current\\_situation/building\\_sector.html](http://www.architecture2030.org/current_situation/building_sector.html)). Increasingly, voluntary goals, such as the AIA 2030 Challenge to achieve carbon neutral buildings by 2030, are becoming regulatory requirements like the U.S. federal law that requires a 55% fossil fuel reduction by 2010 and carbon neutrality by 2030 for all new federal buildings. Improving building energy performance by employing sustainable-design principles presents an enormous opportunity for innovative architecture, engineering, and construction (AEC) practices. Building professionals can dramatically reduce the negative environmental impact of new and renovated buildings.

### SUSTAINABLE DESIGN IN PRACTICE

The world is changing, the economy is changing, and architectural practice is changing. Designing and delivering more sustainable projects can be complex. It requires close coordination across different project stages from design through construction and operation. Many firms are looking for the best way to integrate **building information modeling (BIM)** technology with sustainable-design and analysis tools. BIM is an integrated workflow built on coordinated, reliable information about a project from design through construction and into operations. With BIM, the information required for sustainable-design analysis, code compliance, and certification becomes available as a by-product of the standard design process, making the sustainable-design process inherently more efficient and cost effective.

### ANALYSIS FOR SUSTAINABLE DESIGN

Everything in the built environment is sustained by energy, water, and materials. Design decisions made early in the process can deliver significant results when it comes to the efficient use of these vital resources. Analysis tools for sustainable design enable significant impact on the efficient use of energy, water, and materials in a building design. These tools do the following:

- Empower users to be experts quickly.
- Consider the whole building system.

- Deliver powerful analysis from immense stores of data.
- Interpret results in meaningful way.
- Enable iteration for improvement.

### SUSTAINABLE ENERGY USE

Buildings consume energy throughout their life cycle—from the energy used to create the building materials to the heating, cooling, lighting, and ventilation systems used during building operation, and the equipment used by the occupants for movement such as elevators and various processes such as business equipment. From a sustainable building perspective, once a project is complete it should remain in use for a very long time. Think centuries. Given this time frame, the operational energy of most buildings will be many times greater than that required for the initial construction or renovations. Therefore, to achieve sustainable energy use, a building's total operating energy must first be minimized and then rely on renewable forms of energy to meet its total operating requirements.

### SUSTAINABLE WATER USE

Similar to energy, a building's initial construction and renovations use a much smaller portion of water compared to its operational use over its life. The water uses in the building include requirements for occupant potable and nonpotable needs, HVAC systems, and other processes. To achieve sustainable water use in a building, its use must first be minimized and then it must come from reclaimed and renewable sources. The primary renewable source for water is rainwater catchment, either natural as in surface water or groundwater or as collected by humans in cisterns.

### SUSTAINABLE MATERIAL USE

The construction of a building or other structure requires a significant amount of raw and manufactured materials, such as wood, metal, plastics, and minerals for the structure and finishes, wiring, ductwork, and other system components, fittings, finishes, equipment, various adhesives, gypsum board, glass, concrete, and masonry products. The vast majority of the materials used are nonrenewable, so from the start the project design should have a very long life in mind. The next step is to select materials that are appropriate for the development and benefit of its energy and water-use minimization goals. If reliable data is available, then identify sources for materials that have low manufacturing, supply, and transportation energy and emissions requirements and minimum toxic by-products.

Architects and engineers can use digital design information to analyze and understand how their projects perform before they are built. Developing and evaluating multiple

alternatives at the same time allows easy comparison and makes for better sustainable-design decisions. Building information modeling is core to Autodesk's sustainable-design approach for building performance analysis and simulation.

For example, with Autodesk Green Building Studio® Web service, architects and designers can easily perform whole-building energy, water, and carbon-emission analysis and evaluate the energy profiles and carbon footprints of various building designs. Autodesk Ecotect™ software measures how the environment will affect building performance. The 3-D conceptual analysis tools within Ecotect allow architects and engineers to simulate and analyze in the conceptual and design phases how factors such as solar, shading, lighting, and airflow affect how a building design will operate and perform. Figure 22.95 shows shading analysis at work, and Figure 22.96 shows the result of airflow analysis.

For most building projects, decisions made in the first few weeks of the design end up having the greatest impact on a building's performance. The location of the building on the site, its basic form and orientation, its internal layout and external materials selection, its exterior openings—all of these factors are set very early in the design process. As soon as the layout of a building's walls, windows, roofs, floors, and interior partitions

(elements that define a building's thermal zones) are established, a model is ready for whole-building analyses. A computable Autodesk Revit design model is a great fit for the analyses needed.

## ANALYZING A BUILDING DESIGN

Autodesk's Green Building Studio Web service delivers the ability to exchange and use information between building designs and advanced energy-analysis software programs such as DOE-2, allowing analyses of a building model to be performed by architects, from within their own design environment, directly over the Internet. DOE-2 is an energy modeling program that provides different approaches for defining the building geometry. This streamlines the entire analysis process and allows architects to get immediate feedback on their design alternatives: making green design more efficient and cost effective.

Based on the building's size, type, and location, which drives electricity and water-usage costs, the Green Building Studio Web service determines the appropriate material, construction, system, and equipment defaults by using regional building standards and codes to make intelligent assumptions. Using simple drop-down menus, shown in Figure 22.97,

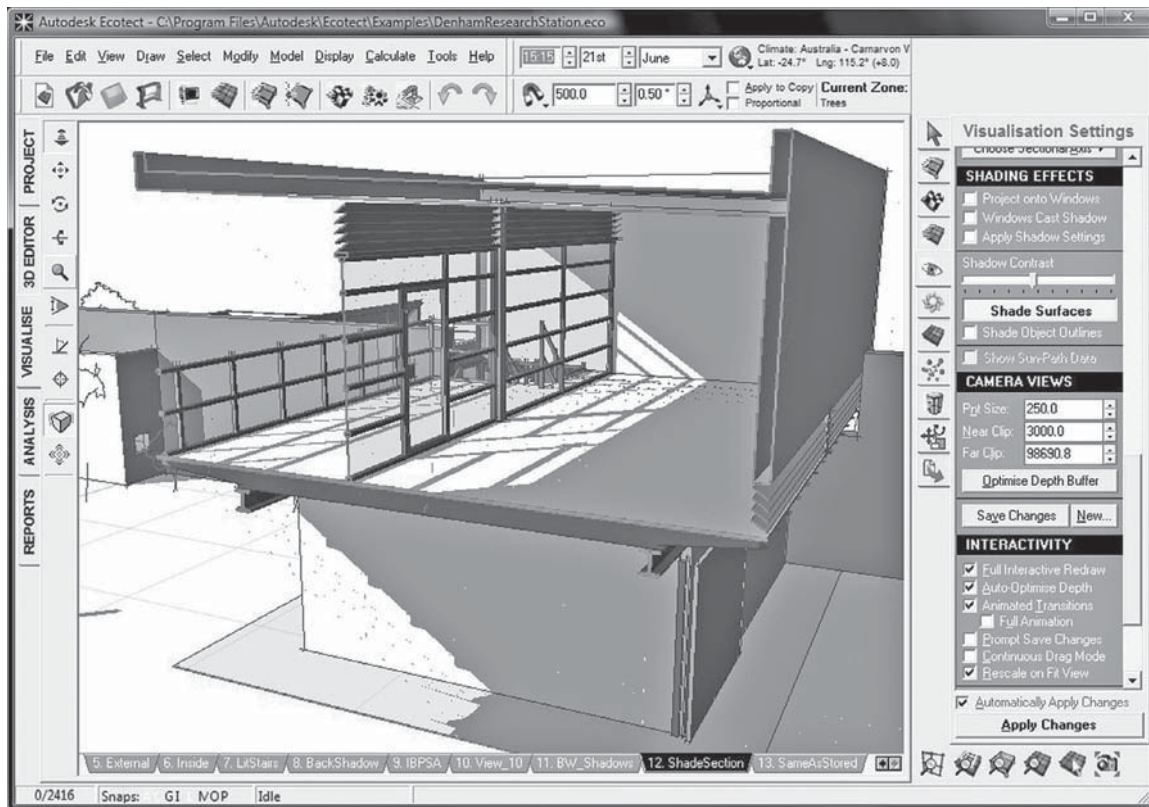
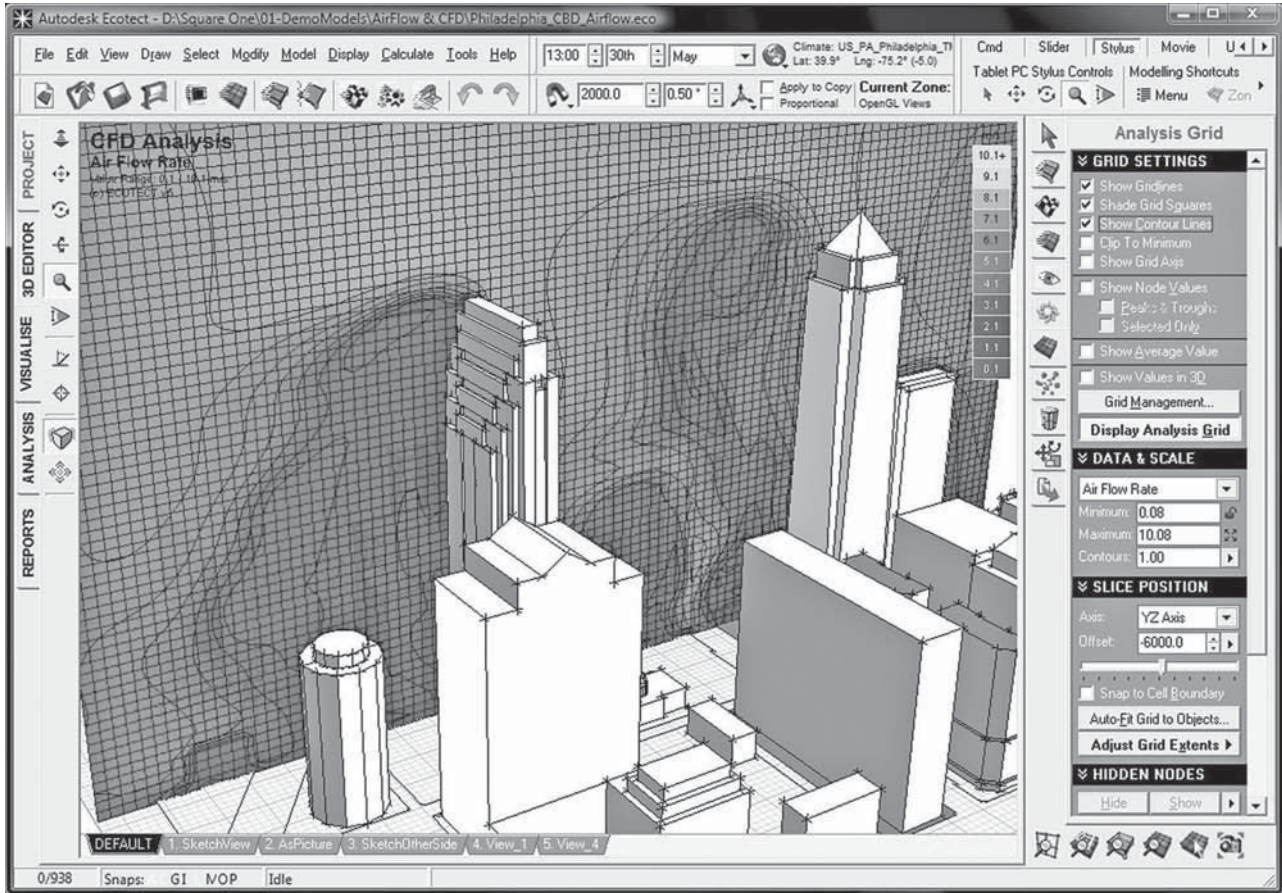


FIGURE 22.95 An example of shading analysis at work.

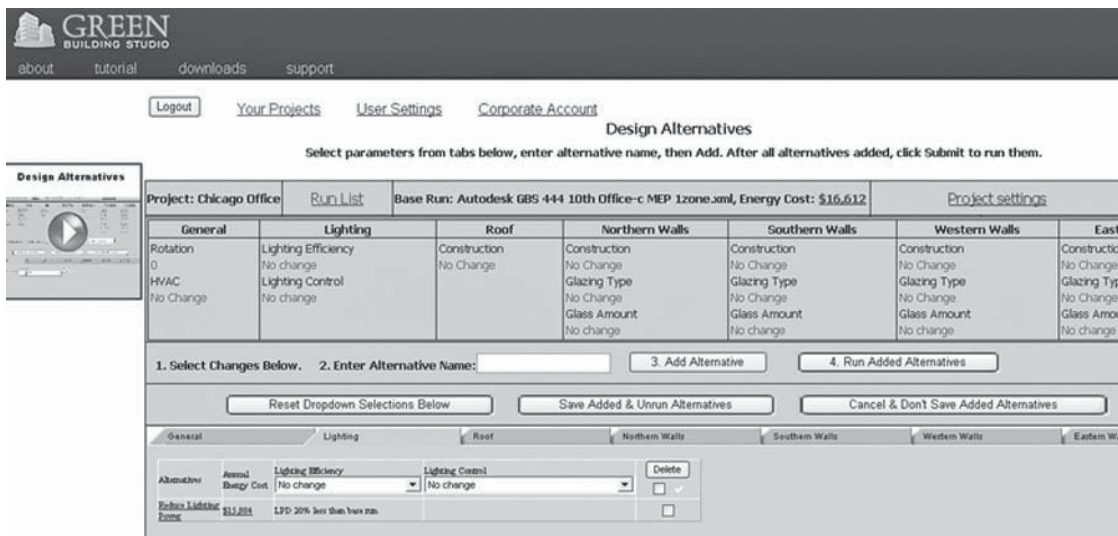
Courtesy Autodesk, Inc.





Courtesy Autodesk, Inc.

FIGURE 22.96 The result of airflow analysis.



Courtesy Autodesk, Inc.

FIGURE 22.97 Using the Green Building Studio drop-down menus, architects can quickly change settings to define specific aspects of their design, such as a different building orientation, a lower U-value window glazing, or a 4-pipe fan coil HVAC system.

architects can quickly change any of these settings to define specific aspects of their design: a different building orientation, a lower U-value window glazing, or a four-pipe fan coil HVAC system, for example.

The Web service uses precise hourly weather data, as well as historical rain data, that are accurate to within 9 miles of any given building site. It also uses emission data for every electric power plant in the United States and includes the broad range of variables needed to assess carbon neutrality.

The software determines a building's carbon emissions and the architect views the output in a Web browser, including the estimated energy and cost summaries as well as the building's carbon-neutral potential. Architects can then explore design alternatives by updating the settings used by the Web service and rerunning the analysis or by revising the building model itself in Revit and then rerunning the analysis. The output also:

- Summarizes water usage and costs.
- Summarizes electricity and fuel costs.
- Calculates an Energy Star score.
- Estimates photovoltaic and wind-energy potential.
- Calculates points toward LEED daylighting credit.
- Estimates natural ventilation potential.

The Autodesk Green Building Studio report is very easy to understand, giving architects the actionable information they need to make greener design decisions.

Autodesk Ecotect software is built specifically by architects who are focused on the building design process. This analysis tool allows designers to simulate a wide array of environmental factors—including shadows, shading, solar, lighting, thermal, ventilation, and acoustics—with a highly visual and interactive display that presents analytical results directly within the context of the building model. This visual feedback allows the software to communicate complex concepts and extensive datasets, and it helps designers engage with comprehensive performance issues early in the schematic phase when designs can be easily changed.

Revit-based design models can be imported directly into Ecotect for analysis throughout the design process. At the start of the design process, early-stage massing models can be used in combination with the site analysis functionality to determine the optimal location, shape, and orientation of a building design based on fundamental environmental factors such as daylight, overshadowing, solar access, and visual impact.

As the conceptual design evolves, whole-building energy solutions, such as Green Building Studio, can be used to benchmark its energy use and recommend areas of potential savings. Once these fundamental design parameters have been established, Ecotect can be used again to rearrange rooms and zones, to size and shape individual openings,

to design custom shading devices, or to choose specific materials based on environmental factors such as daylight availability, glare protection, outside views, and acoustic comfort.

Autodesk Ecotect provides the ability to act on feedback to the designer in the form of visual and interactive displays, which are more than just charts and graphs. The analysis results are presented directly within the context of the model display: shadow animations resulting from shadow casting analysis, surface-mapped information such as incident solar radiation, and spatial volume-related renderings such as daylight or thermal comfort distribution in a room. Surface-mapped information is data, such as lighting levels, shading, or shadowing, that is mapped over building surfaces.

Incident solar radiation is the amount of energy falling on a flat surface. It is not affected in any way by the surface properties of materials or by any internal refractive effects; it is concerned only with the radiation actually striking the surface. Spatial volume-related renderings are 3-D visualizations that help to identify the spatial relationships between different zones, Figure 22.98 shows incident solar radiation analysis at work.

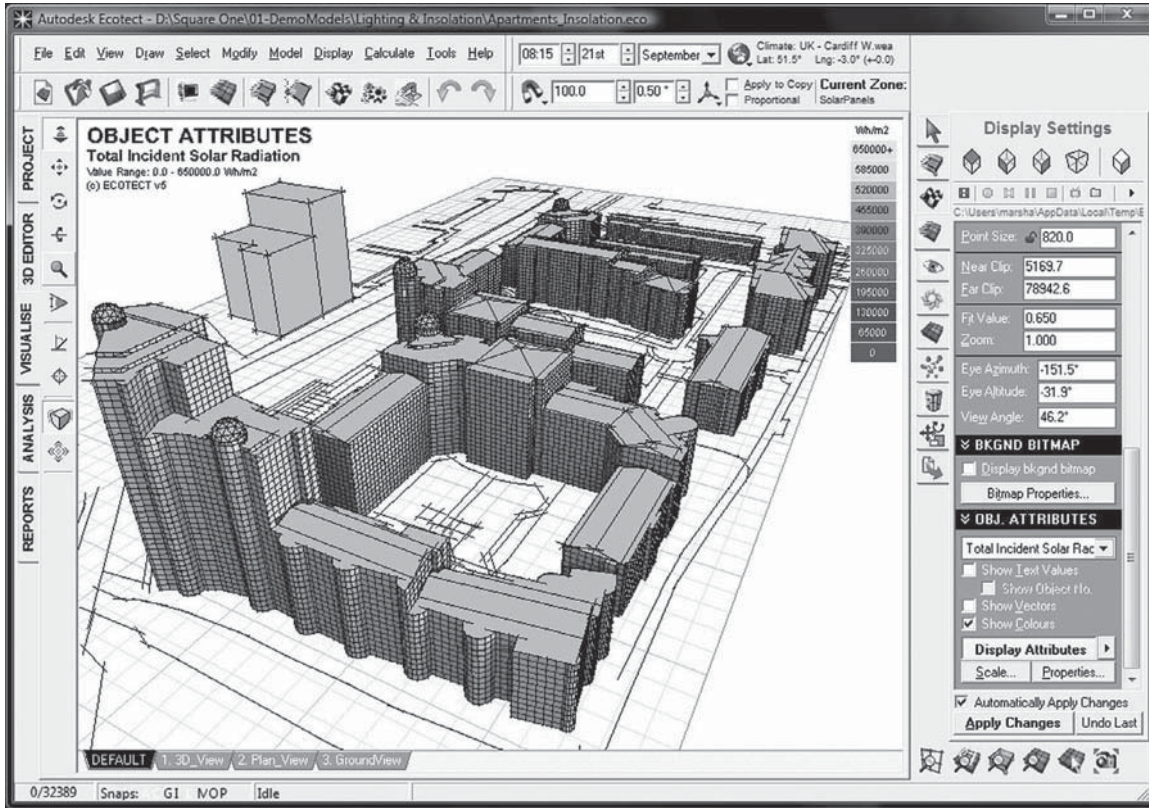
This type of visual feedback lets designers more easily understand and interact with analysis data, often in real time. For instance, a designer can rotate a view of solar radiation to look for variations over each surface or watch an animated sequence of solar rays to see how sunlight interacts with a specially designed light shelf at different times of the year, as shown in Figure 22.99.

During conceptual design, Autodesk Ecotect can be used for a variety of early analyses. For example, the designer can perform overshadowing, solar access, and wind-flow analyses to repeat on a form and orientation that maximizes building performance without infringing on neighboring structures' rights to receive light.

As the design progresses and the elements that define a building's thermal zones are established (the layout of the walls, windows, roofs, floors, and interior partitions), the model can be used for room-based calculations such as average daylight factors, reverberation times, and portions of the floor area with direct views outside.

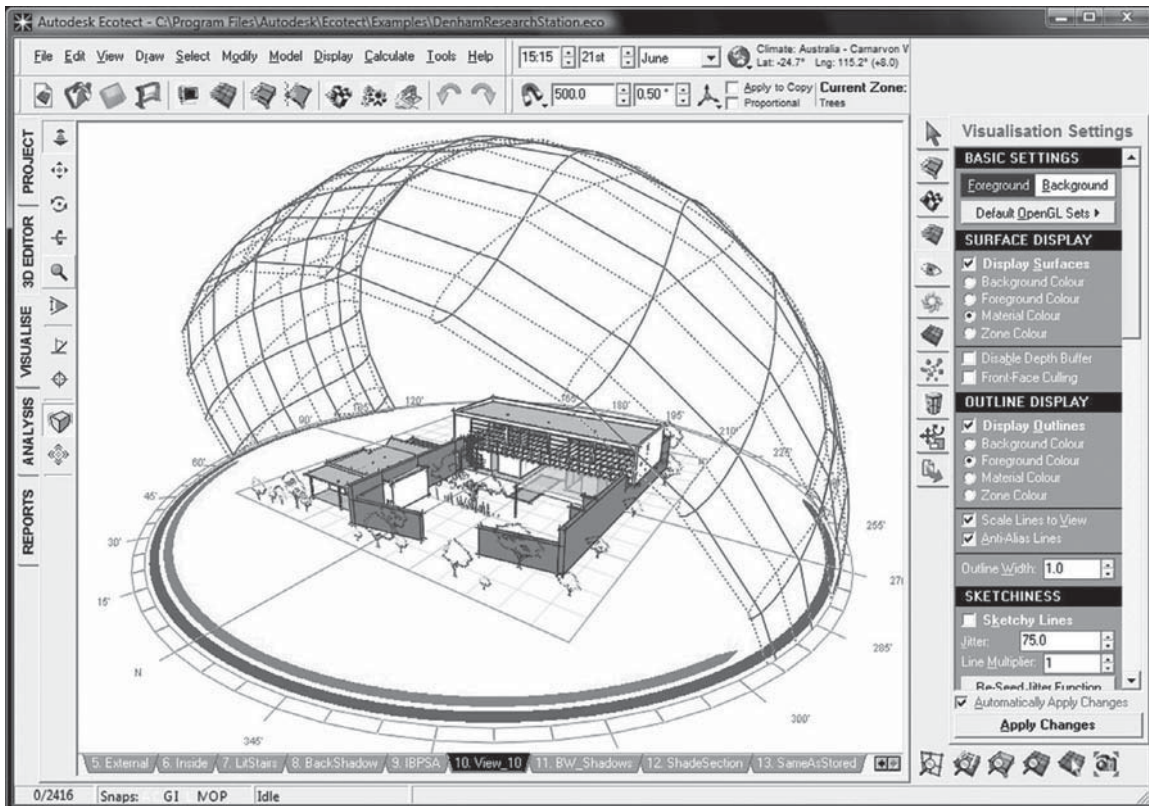
## SUMMARY

The consistent, computable data that comes from a BIM workflow, combined with the breadth of performance analysis and meaningful feedback of Autodesk Green Building Studio and Autodesk Ecotect, provides a complete approach that architects can use to simulate and analyze designs. This feedback, especially during early conceptual design, is critical for architects to optimize the performance of their building designs.



Courtesy Autodesk, Inc.

FIGURE 22.98 Incident solar radiation analysis at work.



Courtesy Autodesk, Inc.

FIGURE 22.99 An animated sequence of solar rays to see how sunlight interacts with a specially designed light shelf at different times of the year.

## DOWNLOAD BUILDING PRODUCT MODELS, DRAWINGS, AND SPECIFICATIONS

The Autodesk Seek ([seek.autodesk.com](http://seek.autodesk.com)) free Web service allows architects, engineers, and other design professionals to discover, preview, and download branded and generic BIM files, models, drawings, and product specifications directly into active design sessions in Autodesk Revit or AutoCAD software. For building product manufacturers, Autodesk Seek offers a unique way to connect with the professional designers ultimately responsible for specifying and recommending their products for purchase. Autodesk Seek provides the following features:

- **Manufacturer-supplied product information:** Access building information models, drawings, and product specifications for more than 35,000 commercial and residential building products from nearly 1000 manufacturers.
- **Powerful parametric search technology:** Search by key attributes, including dimensions, materials, performance, sustainability, or manufacturer name using industry-standard classifications.
- **Preview and explore models before downloading:** View, rotate, zoom, and slice product models and then

download the accurate files directly into your design session. For Revit models, preview the family parameters and associated type catalogs before downloading.

- **Multiple formats:** Select the formats that work for you, such as Revit, DWG™, DGN, and SKP files; Microsoft® Word documents; three-part specifications; and PDFs.
- **Share designs:** You can share designs with peers by uploading them directly from your AutoCAD files to the Autodesk Seek User Uploads. Easily access the Share with Autodesk Seek button from the Output panel of the ribbon tab. You can choose to share the current drawing or select a block definition within the drawing. Thumbnails, title, and metadata are automatically extracted and indexed. Shared designs can be searched and downloaded by anyone.

When using Autodesk Seek, your default browser launches and displays search results. Figure 22.100 shows the browser open with a sample of structural search results. A complete set of structural applications are provided in the actual search. Move your cursor over the thumbnail image of the item to view an enlarged image and description of the product. To the right of each structural item are viewing options such as DWG, RFA, DXF, PDF, and Word files.

Similar products are available from other CADD software developers and from product manufacturers.

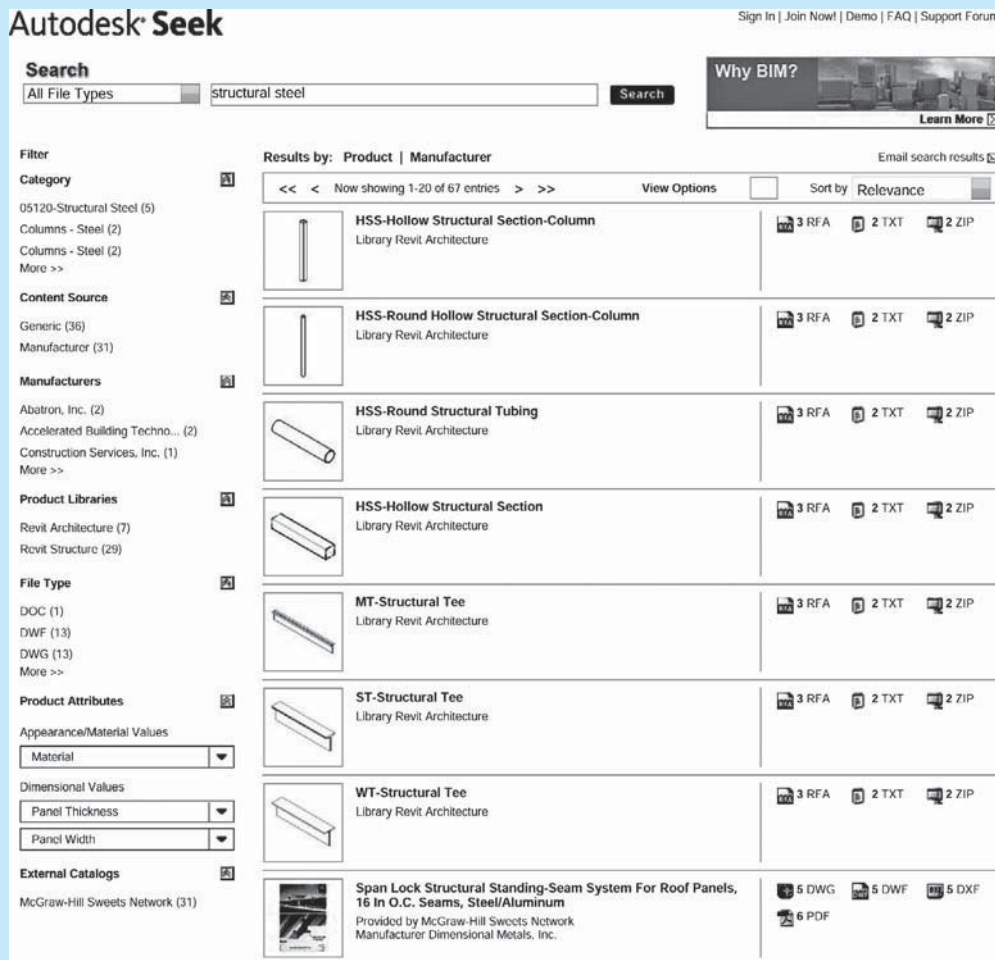


FIGURE 22.100 The browser open with a sample of structural search results displayed using Autodesk Seek.

Courtesy Autodesk, Inc.

# PROFESSIONAL PERSPECTIVE

The drafting procedure for the preparation of structural drawings is often complicated by the amount of information to be contained in these drawings. Structural drawings are normally done on large sheets with as much information as possible placed on each sheet. The first task is to determine the sheet size. This may already be decided as a standard within the company—for example, 22 × 34. The factors that should be considered when selecting sheet size or when drawing on predetermined sheet sizes are:

- The size of the plan.
- The number of dimensions and notes needed.

- The scale used.
- The number of details to be placed on the sheet.
- The amount of free space required for possible future revisions.

All of these issues must be considered, because you do not want to end up with some sheets that are overcrowded and others that have little information. Use CADD layers such as those specified by the United States National CAD Standard (NCS) or more basic systems such as FL1, FL2, FDN, ROOF, ELEV, and NOTES.

## DESIGNING AN OBSERVATION PLATFORM

**Problem:** Suppose a building code states that the rise between stair treads cannot exceed 8" for a 12" tread. Find the minimum distance for dimension L and a corresponding angle A in Figure 22.101 of an observation platform.

**Solution:** Geometrical figures are **similar** when they have the same shape. They are **congruent** when they have the same shape and size. When two triangles are similar, proportional equations can be written. In this design problem, you have similar triangles: the large staircase and the smaller single tread (see Figure 22.102).

Set up a proportion

$$\frac{23}{x} = \frac{8}{12}$$

which gives

$$x = 34.5'$$

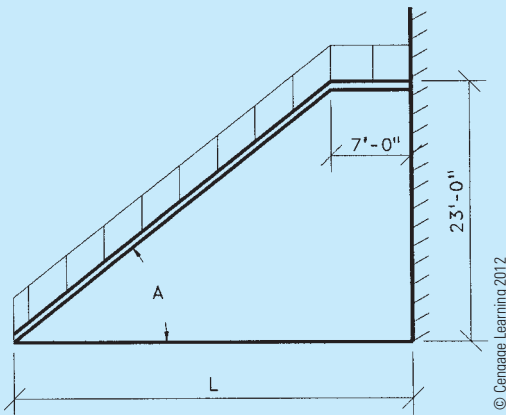


FIGURE 22.101 Observation platform.

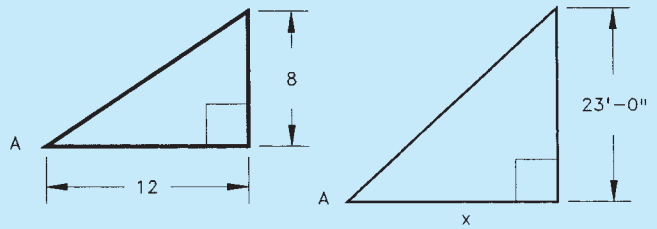


FIGURE 22.102 Two similar triangles. © Cengage Learning 2012

The dimension L is an additional 7':

$$L = 34.5 + 7 = 41.5' \text{ or } 41'-6''$$

Also, because we are dealing with right triangles, angle A can be found by the application of one trig function:

$$A = \text{Inv tan } \frac{8}{12} = 33.7^\circ$$

It is often necessary for the drafter to calculate the weight and cubic yard of concrete for bills of materials, cost estimates, and construction purposes. The following formulas can be used to make these calculations:

$$\begin{aligned} (\text{Length} \times \text{Width} \times \text{Height}) \times 150 &= \text{Total weight} \\ (\text{Length} \times \text{Width} \times \text{Height}) \div 27 &= \text{Cubic yard} \end{aligned}$$

**Problem:** Given a precast concrete panel with the dimensions 18'-4" long, 1'-4" wide, and 2'-0" high, calculate the weight in pounds and the volume in yards.

**Solution:**

$$\begin{aligned} 18'-4'' \times 1'-4'' \times 2'-0'' &= 48.88889 \text{ cubic feet} \\ 48.88889 \times 150 &= 7333.3333 \text{ lb} \\ 48.88889 \div 27 &= 1.81 \text{ cubic yards} \end{aligned}$$

If there are holes or cutouts, then it is necessary to calculate the combined volume and weight of these and subtract them from the total.

## WEB SITE RESEARCH

Use the following Web sites as a resource to help find more information related to engineering drawing and design and the content of this chapter.

Address	Company, Product, or Service
seek.autodesk.com	Autodesk Seek Web service
www.aci-int.org	American Concrete Institute (ACI)
www.aia.org	American Institute of Architects (AIA)
www.aisc.org	American Institute of Steel Construction (AISC)
www.aist.org	Association for Iron and Steel Technology (AIST)
www.aluminum.org	The Aluminum Association
www.amazon.com	Search author Madsen for <i>Architectural Drafting and Design</i> , <i>Architectural Drafting Using AutoCAD</i> , and <i>Architectural Desktop and Its Applications</i> textbook titles.
www.ansi.org	American National Standards Institute (ANSI)
www.arcat.com	Building materials information, specifications, and CAD details
www.asme.org	American Society of Mechanical Engineers (ASME)
www.astm.org	American Society for Testing Materials (ASTM)
www.awc.org	American Wood Council (AWC)
www.bcewp.com	Boise Cascade Engineered Wood Products Division
www.buildingteam.com	Building and construction industry links
www.capterra.com	Construction Documents and Management Software
www.concrete.com	Concrete services and information
www.cpci.ca	Canadian Precast and Prestressed Concrete Institute (CPCI)
www.crsi.org	Concrete Reinforcing Steel Institute (CRSI)
www.csc-dcc.ca	Construction Specifications Canada (CSC)
www.csinet.org	Construction Specifications Institute (CSI)
www.cengage.com	Publisher of the textbooks <i>Architectural Drafting and Design</i> by Jefferis, Madsen, and Madsen; and <i>Print Reading for Architecture and Construction Technology</i> , by Madsen and Jefferis
www.greenformat.com	Construction Specifications Institute GreenFormat
www.g-w.com	Publisher of the textbooks <i>Architectural Drafting Using AutoCAD</i> by David A. Madsen, David P. Madsen, and Ron Palma
www.hud.gov	United States Department of Housing and Urban Development (HUD)
www.industrialpress.com	<i>Machinery's Handbook</i> materials and processes
www.nahb.org	National Association of Home Builders (NAHB)
www.pci.org	Precast and Prestressed Concrete Institute (PCI)
www.precast.org	National Precast Concrete Association (NPCA)
www.prnewswire.com	Willamette Industries
www.steel.org	American Iron and Steel Institute (AISI)
www.steel-sci.org	Steel Construction Institute (SCI)
www.strongtie.com	Simpson Strong Tie information and catalog
www.tilt-up.org	Tilt-Up Concrete Association (TCA)
www.uss.com	U.S. Steel Corporation (USS)
www.wirereinforcementinsitute.org	Wire Reinforcement Institute (WRI)
www.world-aluminum.org	International Aluminum Institute (IAI)
www.worldsteel.org	International Iron and Steel Institute

## Chapter 22 Structural Drafting Test



To access the Chapter 22 test, go to the Student CD, select **Chapter Tests and Problems**, and then **Chapter 22**. Answer the questions

with short, complete statements, sketches, or drawings as needed. Confirm the preferred submittal process with your instructor.

## Chapter 22 Structural Drafting Problems

### INSTRUCTIONS

1. Read all related instructions before you begin working.
2. Use a Gothic, Arial, RomanS, or architectural font style. Confirm the preferred text style with your instructor.
3. Use the engineering sketches to prepare a complete set of drawings for the given problems.
4. Do all drawings on 22" × 34" or 24" × 36" (AI and AO metric) sheets unless otherwise specified by your instructor. Use an architectural-style border and title block, with the title block along the right side of the sheet or along the bottom of the sheet. Confirm the preferred border and title block with your course guidelines.
5. Use proper sectioning and detailing techniques as correlated to the engineering sketches. Some recommended scales are provided. You can increase or decrease the scale, depending on the available space and the complexity of the section or detail. Sections and details should be drawn at a minimum scale of  $3/8" = 1'-0"$  (1:20 metric). Judgment should be used if a section or detail requires a lot of information. A larger scale ranging from  $3/4"$  to  $1-1/2" = 1'-0"$  (1:10 metric) should be considered.
6. It is recommended that you evaluate the entire set of sketches for each problem before beginning to draw. Information needed to draw one problem may be found on the sketch or data for another problem or on another page or view. The problems are real drafting situations, so you will interpret rough engineering sketches and prepare formal drawings using the best drafting techniques and standards that you have learned.
7. It is suggested that drawing sheets be organized with as much information as possible without crowding or reducing clarity. If additional drawing area is required, then it would be better to add another sheet than to overcrowd the drawing.
8. Some problems in this chapter may contain errors, missing information, or slight inaccuracies. This is intentional and is meant to encourage you to apply appropriate problem-solving methods and engineering and drafting standards in order to solve the problems. This is meant to force you to think about each part and how parts fit together in the structure. As in **real-world** projects, the engineering problem should be considered as a basis for your preliminary layouts. Always question inaccuracies in project designs and consult with the proper standards and other sources. In some cases, an error might be the source of engineering changes provided by your instructor. However, this is determined by your specific course objectives. Other situations may require that corrections be made during the development of the original design drawings. This is not intended as a source of frustration; it is considered to be part of the engineering drafter's daily responsibility in project development.
9. After completion of assigned drawings and complete sets of working drawings, your instructor can make drawing changes for you to complete using the drawing revision practices discussed in this chapter. This option depends on your course objectives and your instructor's preference.



### Drafting Templates

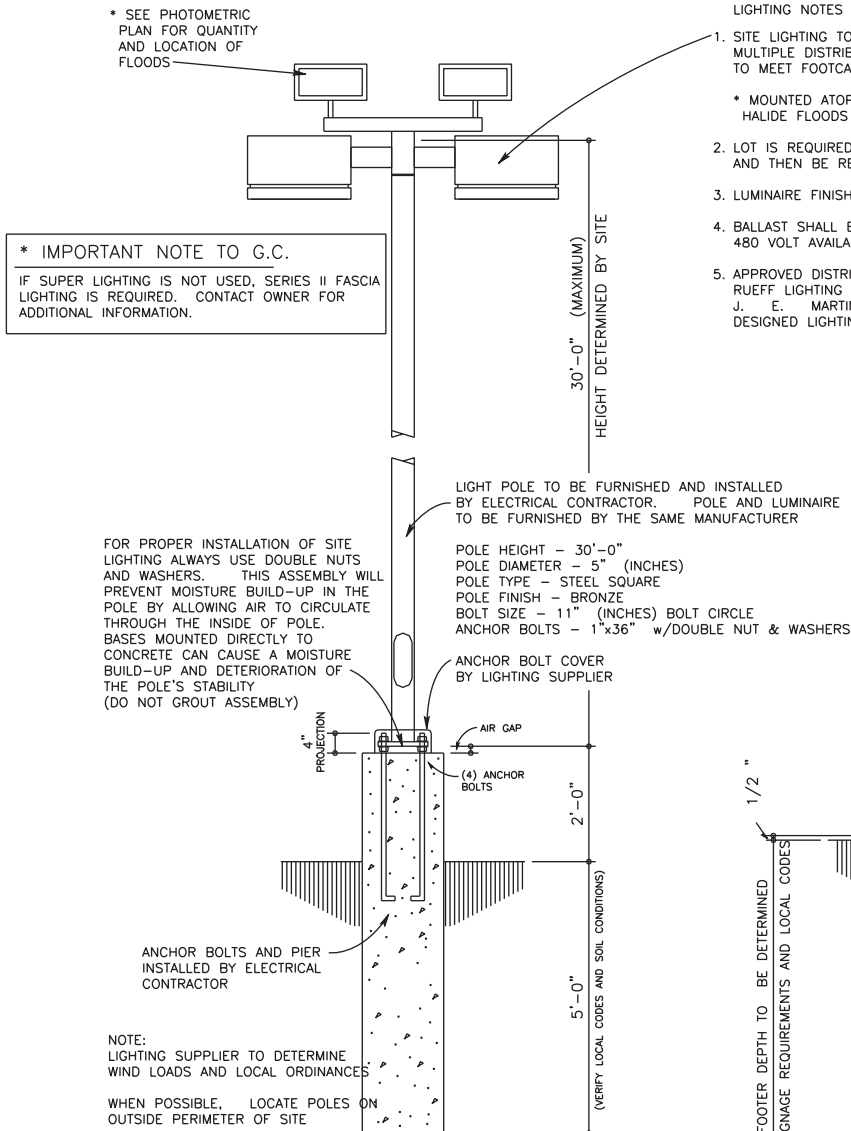
To access CADD template files with predefined drafting settings, go to the Student CD, select **Drafting Templates**, and then select the appropriate template file.

Part 1: Problems 22.1 and 22.2

**PROBLEM 22.1** Exterior pole light, sign footing, curb details, and sidewalk and paving details

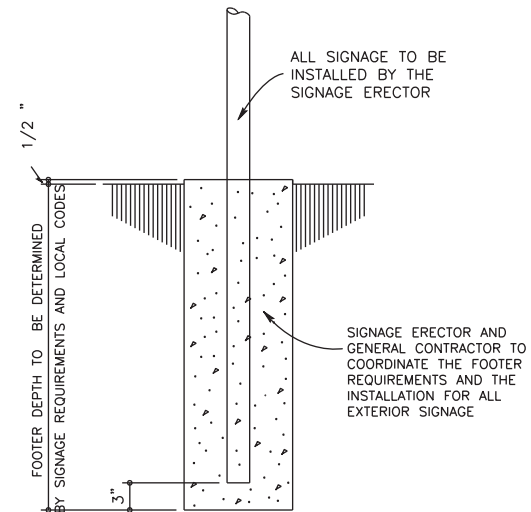
Draw the following details on one sheet unless otherwise specified by your instructor.

Drawings courtesy of Wendy's International, Inc.



- LIGHTING NOTES
- SITE LIGHTING TO BE A 1000 WATT METAL HALIDE VERTICAL BURN FIXTURE. MULTIPLE DISTRIBUTION SHAPES (TYPES 1, 2, 3, 4) WILL BE ALLOWED TO MEET FOOTCANDLE REQUIREMENTS USING SEGMENTED OPTICS
  - \* MOUNTED ATOP DESIGNATED POLES WILL BE TWO (2) 400 WATT METAL HALIDE FLOODS DIRECTED TOWARD THE BUILDING (SUPER LIGHTING)
  - LOT IS REQUIRED TO HAVE AN INITIAL AVERAGE OF 10 FOOTCANDLES AND THEN BE REQUIRED TO MAINTAIN A MINIMUM OF 2 FOOTCANDLES
  - LUMINAIRE FINISH TO BE BRONZE
  - BALLAST SHALL BE MULTITAP 120, 208, 240, OR 277 VOLT 480 VOLT AVAILABLE UPON REQUEST WITH A TWO (2) YEAR WARRANTY
  - APPROVED DISTRIBUTORS:  
RUEFF LIGHTING 1-800-678-1532  
J. E. MARTIN ASSOC. 1-800-462-8235  
DESIGNED LIGHTING CONCEPTS 1-800-248-5483

- GENERAL NOTES
- ALL SIGNS SHALL BE ERECTED IN ACCORDANCE WITH ALL LOCAL CODES AND SOIL CONDITIONS.
  - DESIGNS ARE TO BE DETERMINED BY SIGN SUPPLIER (VERIFY LOCAL WIND AND SOIL CONDITIONS).
  - ALL PAINTED PAVEMENT MARKERS ARE TO BE SOLID YELLOW AND FURNISHED BY GENERAL CONTRACTOR.
  - WHEN UNABLE TO VIEW CARS PLACING ORDERS DIRECTLY FROM PICK-UP WINDOW A 24" CONVEX MIRROR SHALL BE PLACED IN AN APPROPRIATE LOCATION TO VIEW CUSTOMERS AT ORDER STATION.



EXTERIOR POLE LIGHTS

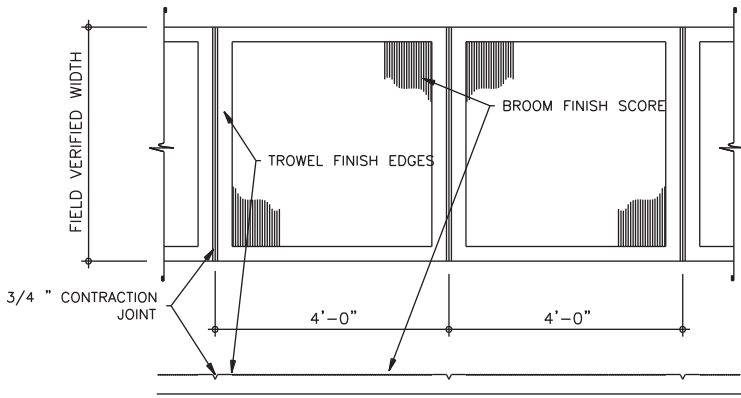
SCALE: 1/2" = 1'-0"

EXTERIOR SIGNAGE FOOTER

SCALE: 1" = 1'-0"

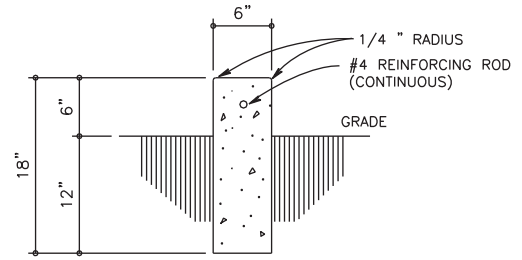


PROBLEM 22.1 (Continued)



SIDEWALK FINISH DETAIL

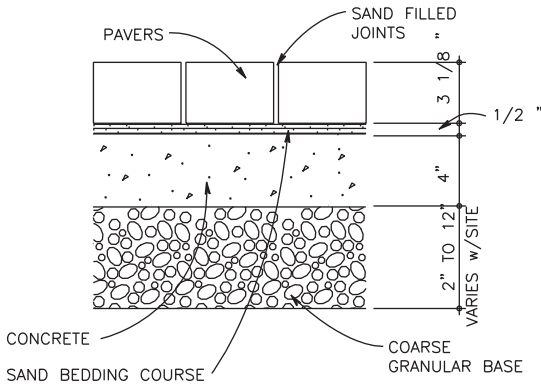
NO SCALE



NOTE: ALL CONCRETE CURBS TO HAVE EXPANSION JOINTS OR SAW CUTS NOT MORE THAN 20'-0" APART

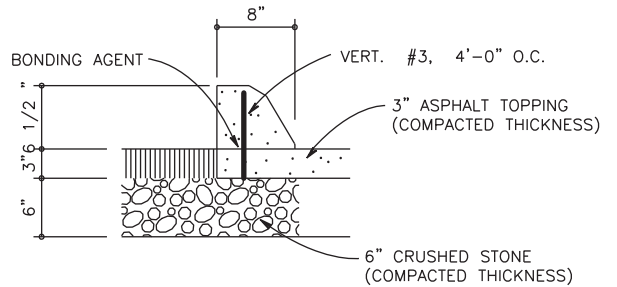
CONCRETE CURB DETAIL

SCALE: 1" = 1'-0"



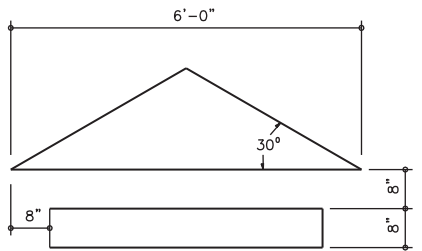
PAVER DETAIL

NO SCALE:



EXTRUDED CURB DETAIL

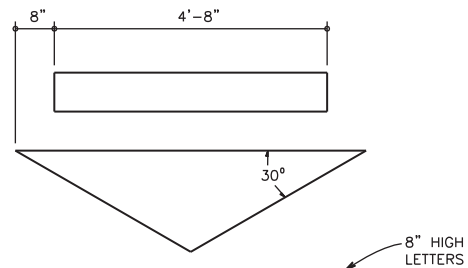
SCALE: 1" = 1'-0"



PICK-UP  
WINDOW  
8" HIGH LETTERS

PAVEMENT MARKER DETAILS

SCALE: 1/2" = 1'-0"



EXIT ONLY  
8" HIGH LETTERS

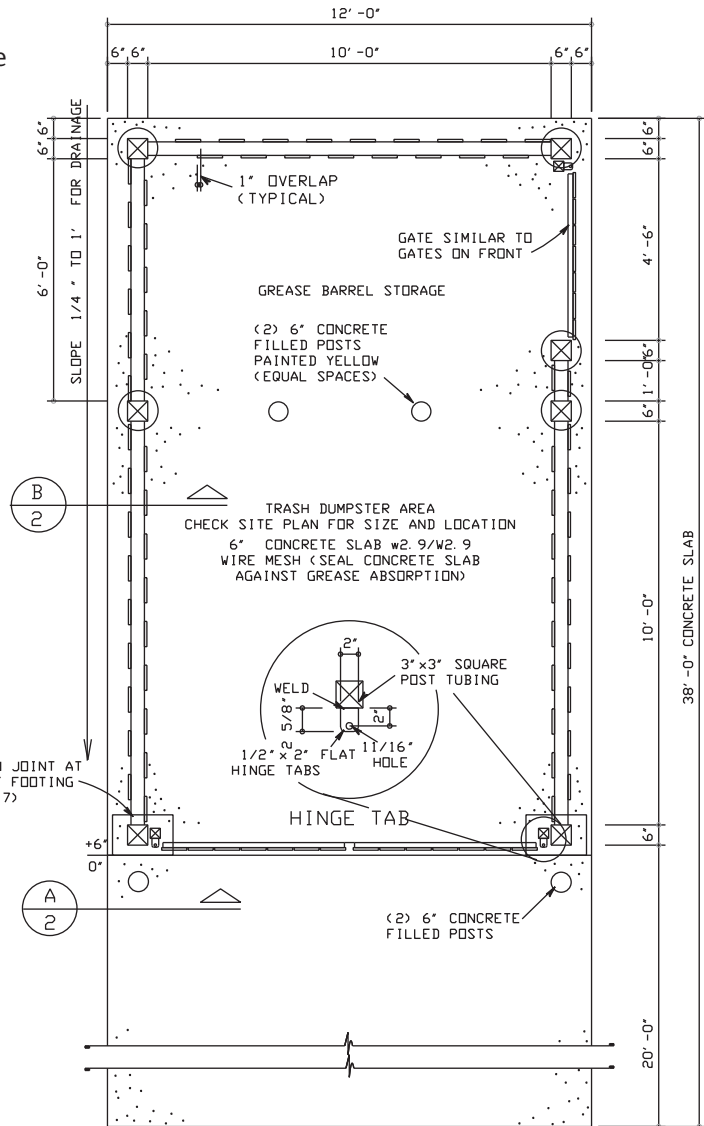
PAVEMENT MARKER DETAILS

SCALE: 1/2" = 1'-0"

**PROBLEM 22.2** Trash enclosure drawings

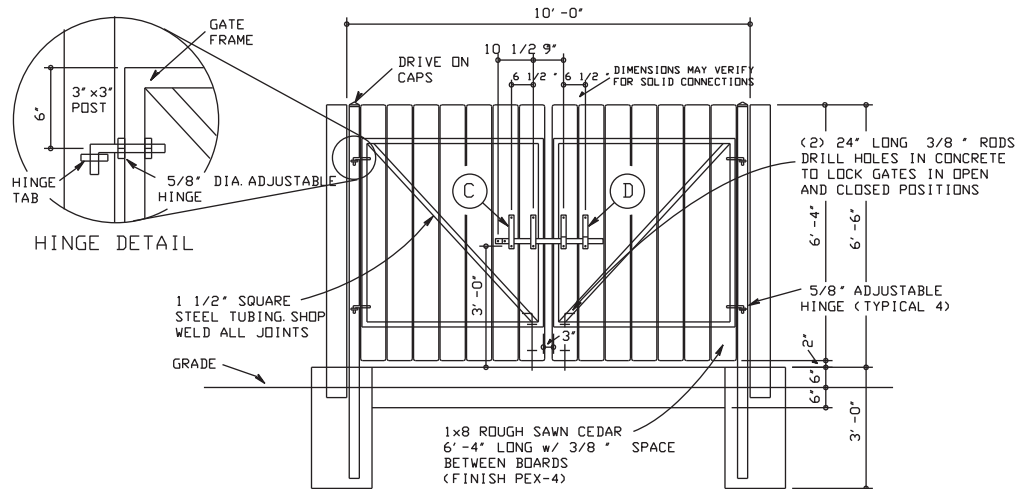
Given the following layouts, draw the trash enclosure plan, elevation, sections, and details on one sheet, unless otherwise specified by your instructor.

*Drawings courtesy of Wendy's International, Inc.*



STANDARD TRASH ENCLOSURE PLAN

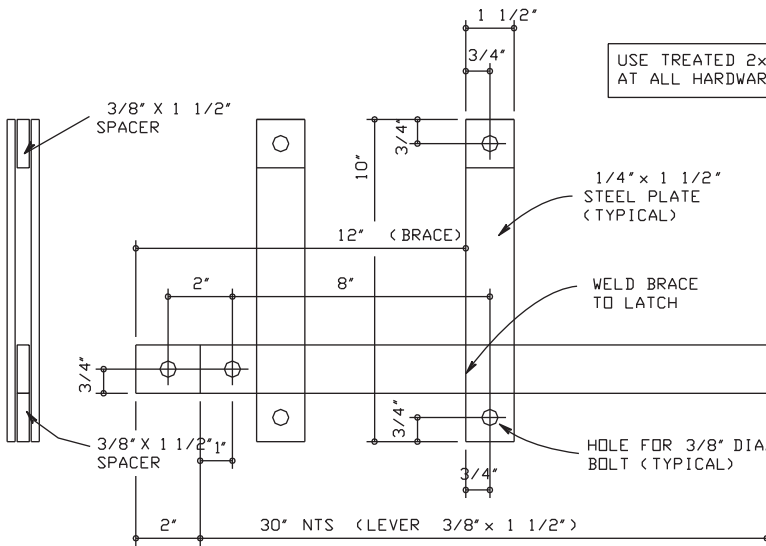
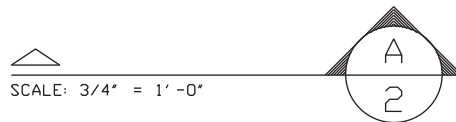
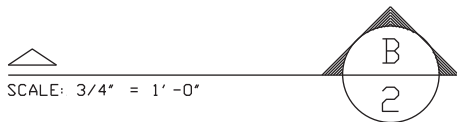
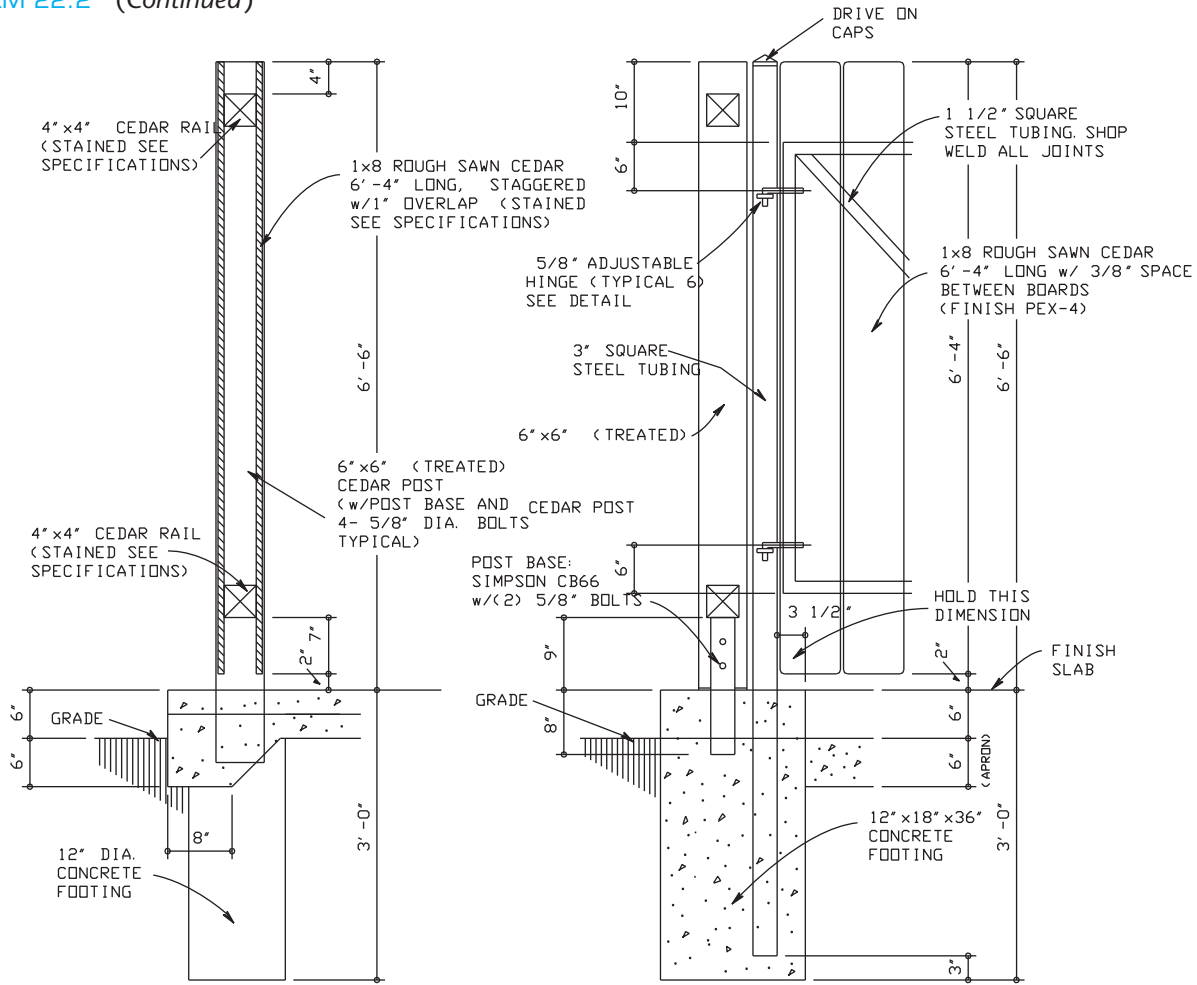
SCALE: 3/8" = 1'-0"



TYPICAL FRONT ELEVATION

SCALE: 3/8" = 1'-0"

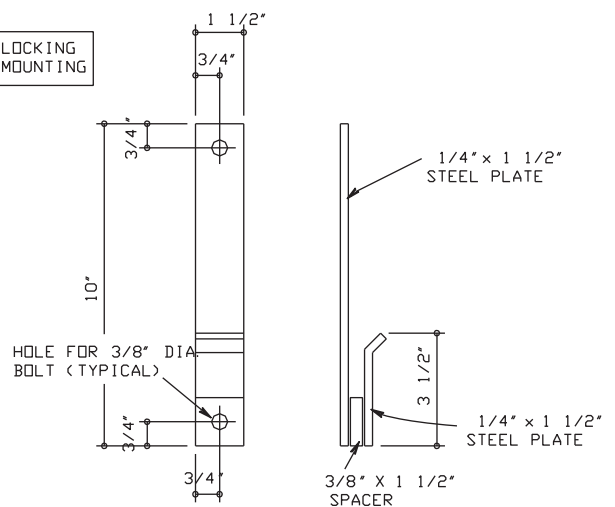
PROBLEM 22.2 (Continued)



GATE LATCH DETAIL (1 REQUIRED) C

SCALE: 3" = 1'-0"

USE TREATED 2x BLOCKING AT ALL HARDWARE MOUNTING



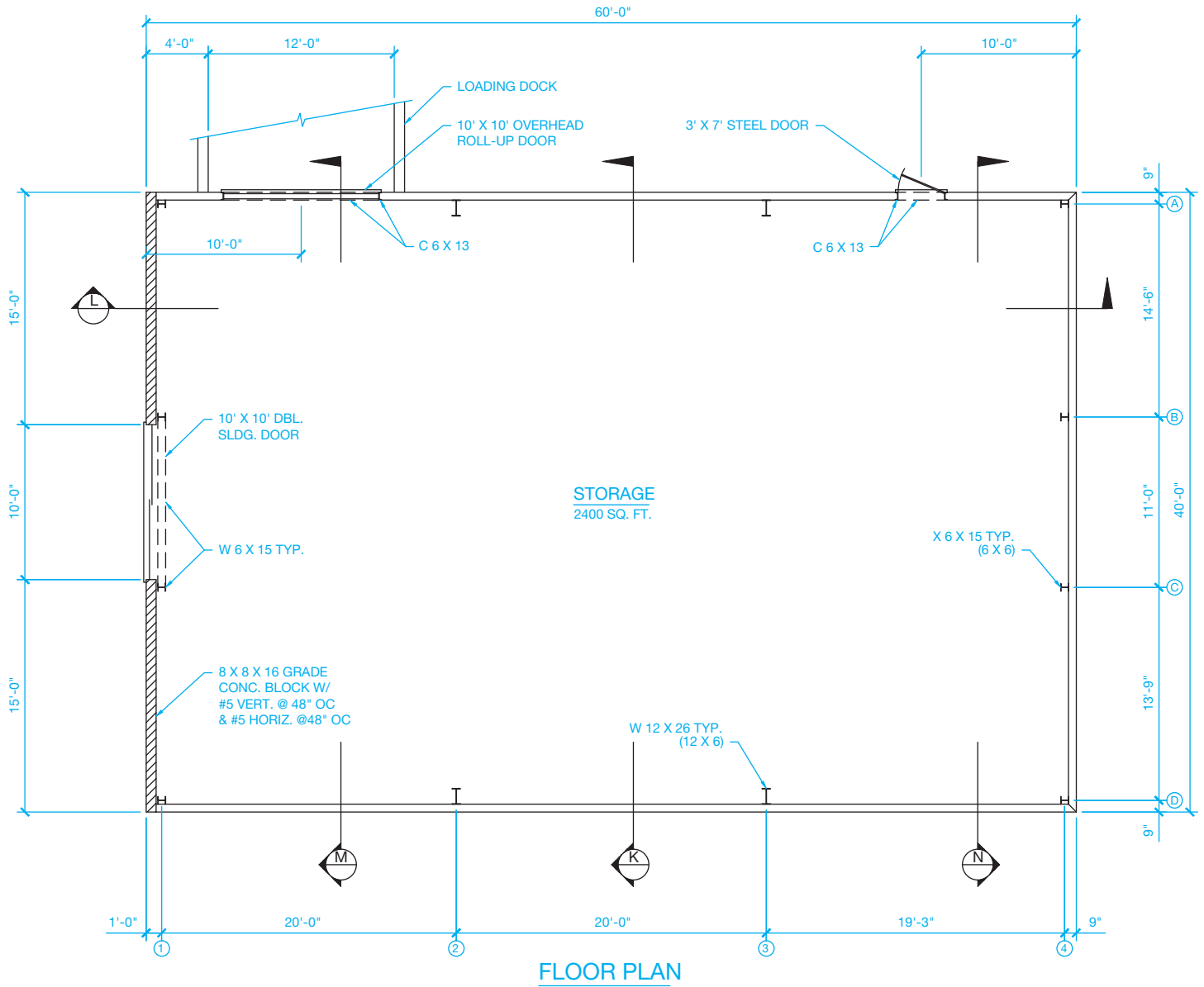
GATE LATCH DETAIL (2 REQUIRED) D

SCALE: 3" = 1'-0"

Part 2: Problems 22.3 Through 22.19

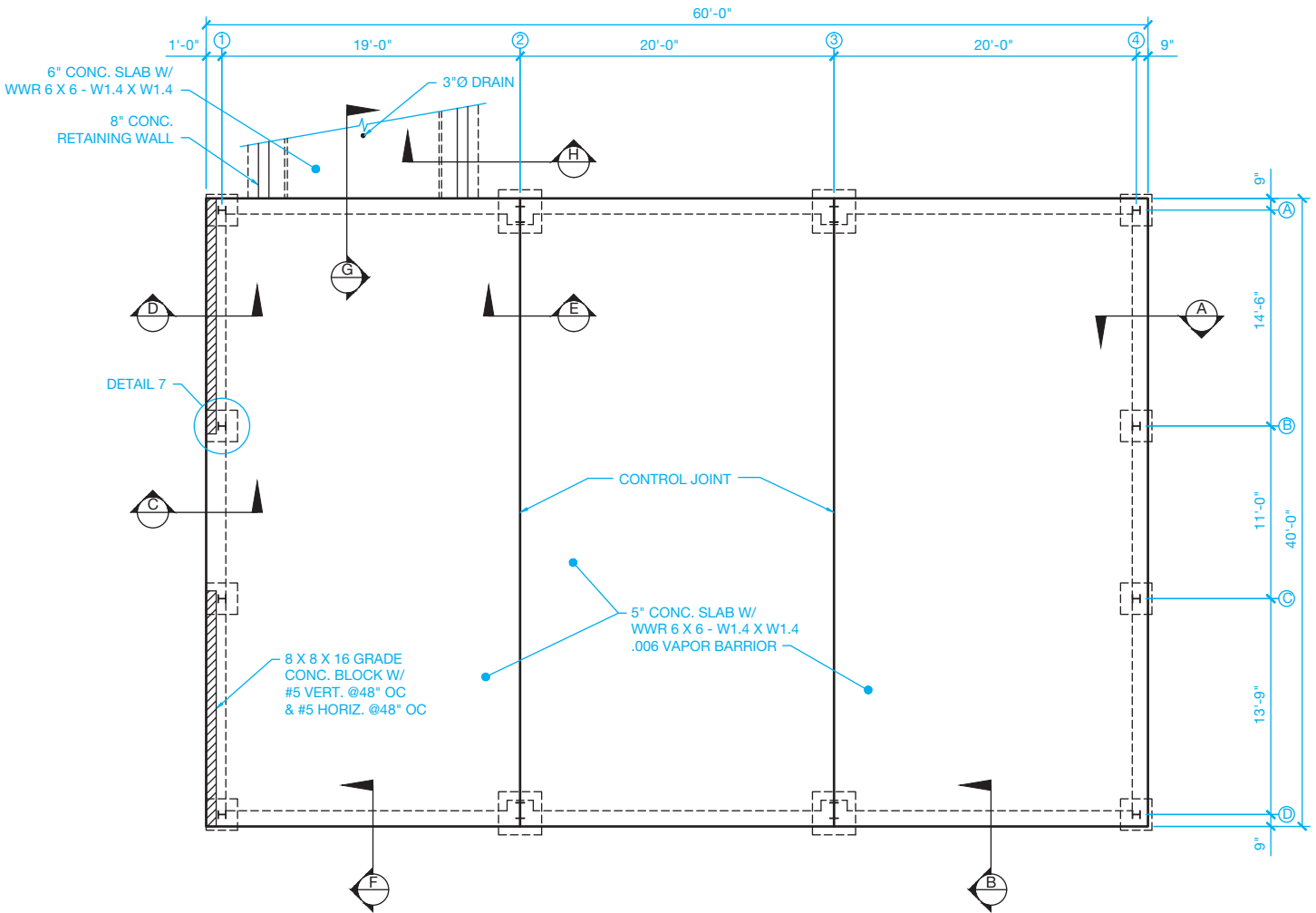
Problems 22.3 through 22.19 are the drawings for a 2400 sq. ft. storage building.

PROBLEM 22.3 Storage building floor plan



© Cengage Learning 2012

PROBLEM 22.4 Foundation plan

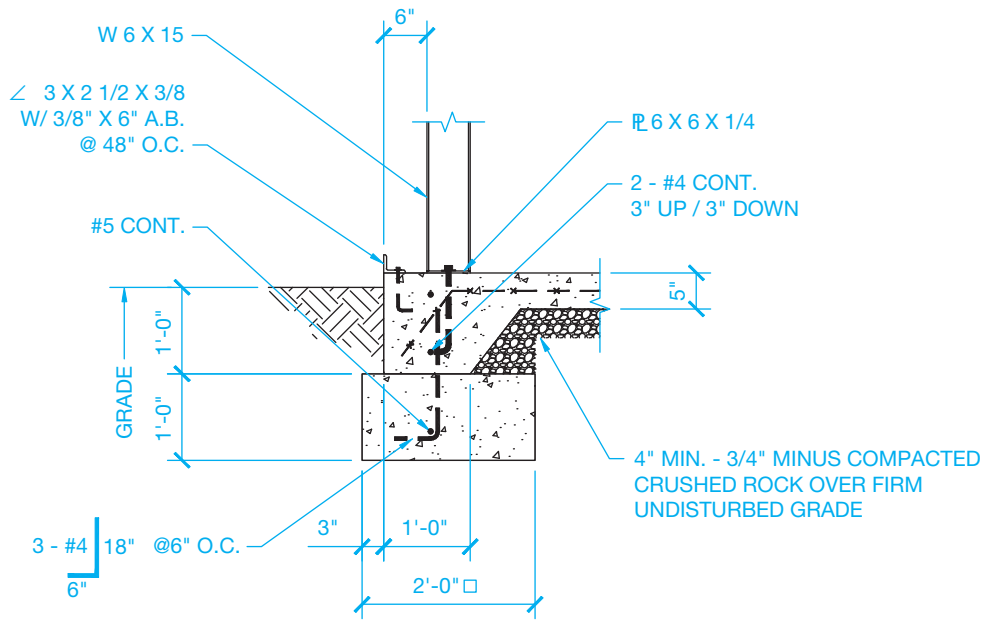
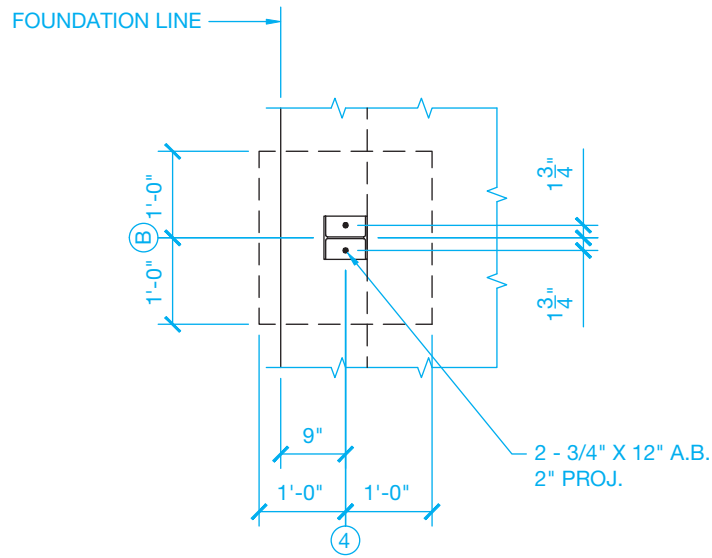


GENERAL NOTES:

1. ALL CONC. TO BE 2500 PSI @28 DAYS MIN. COMP. STRENGTH.
2. ASSUME SOIL BEARING PRESSURE IS 2000 PSF.
3. LAP ALL STEEL 40 X DIA. MIN.

FOUNDATION PLAN

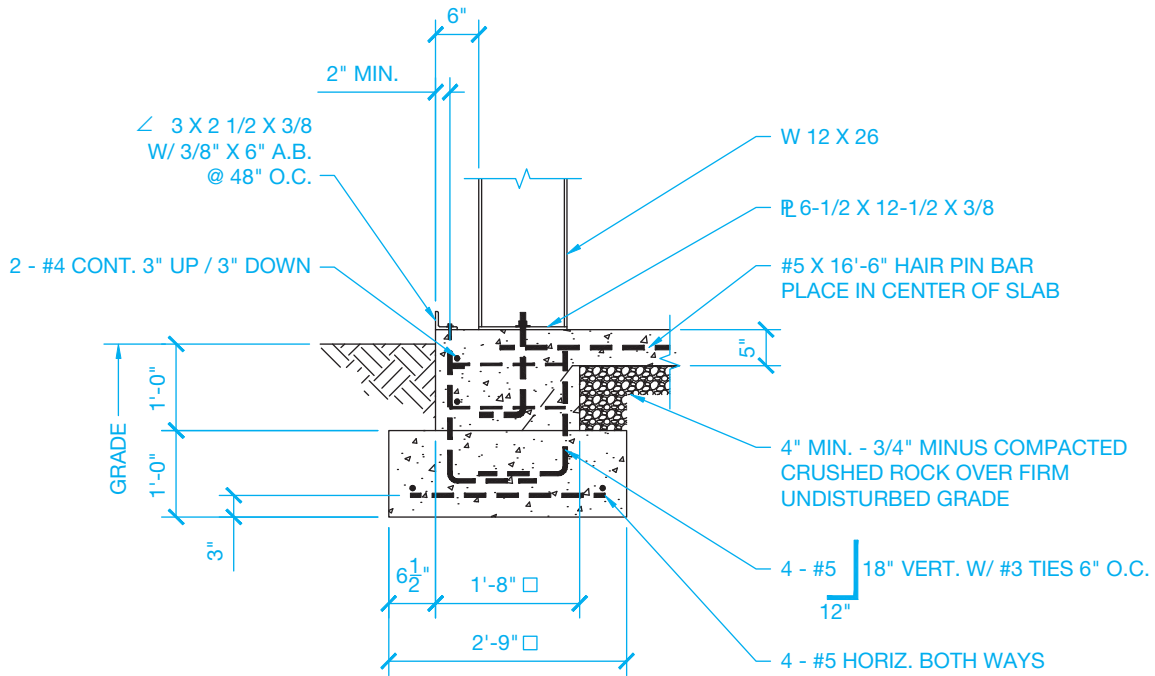
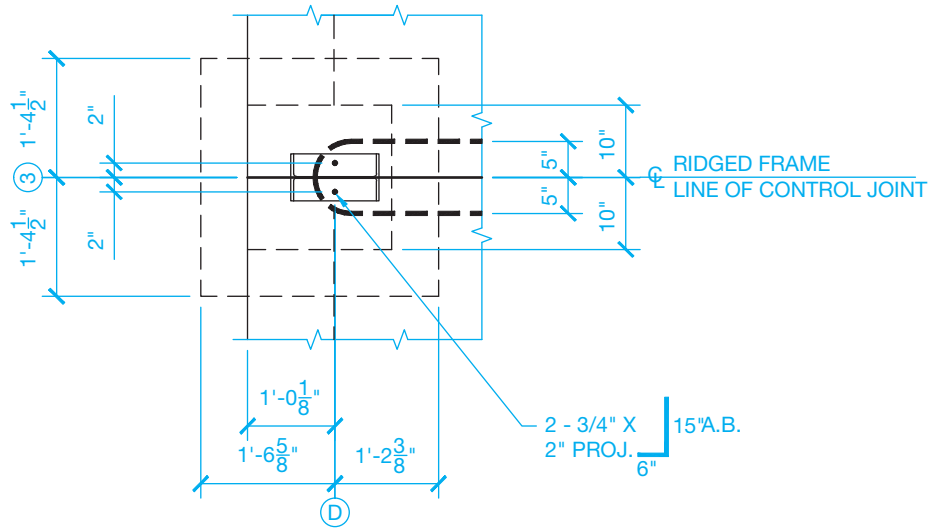
PROBLEM 22.5 Section A, Footing



**SECTION A**  
SCALE: 3/4" = 1'-0"

© Cengage Learning 2012

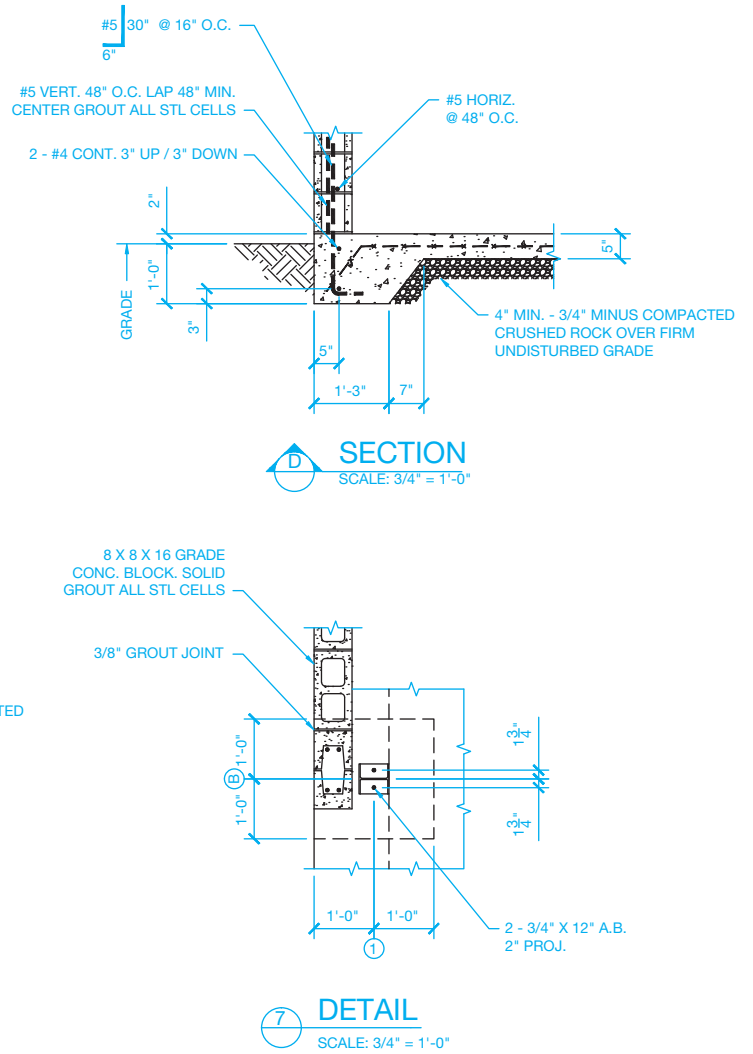
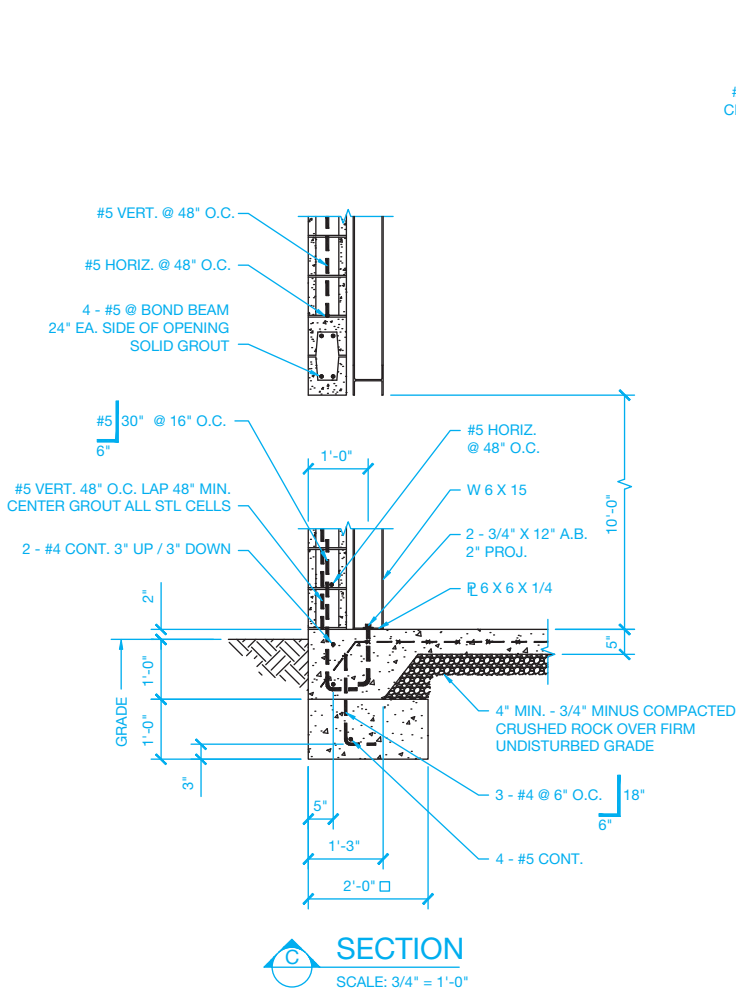
PROBLEM 22.6 Section B, Footing



**SECTION B**  
SCALE: 3/4" = 1'-0"

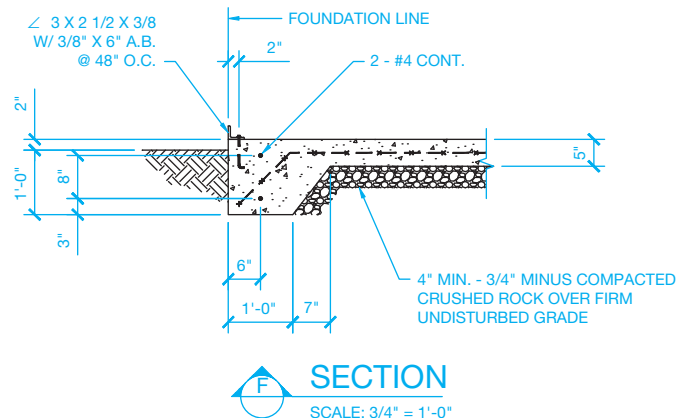
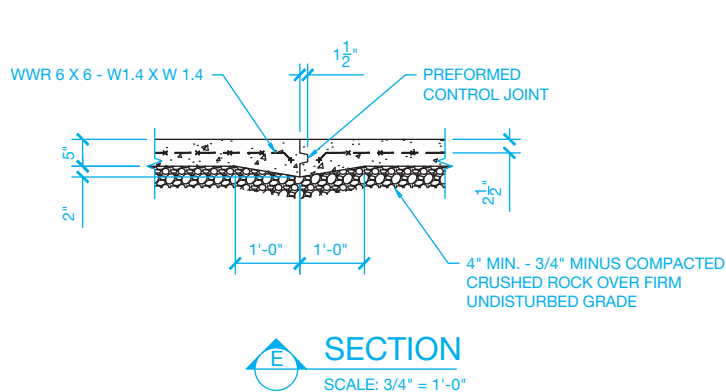
© Cengage Learning 2012

**PROBLEM 22.7** Section C, Footing and concrete blocks; Section D, Footing; Detail 7, Bond beam detail



© Cengage Learning 2012

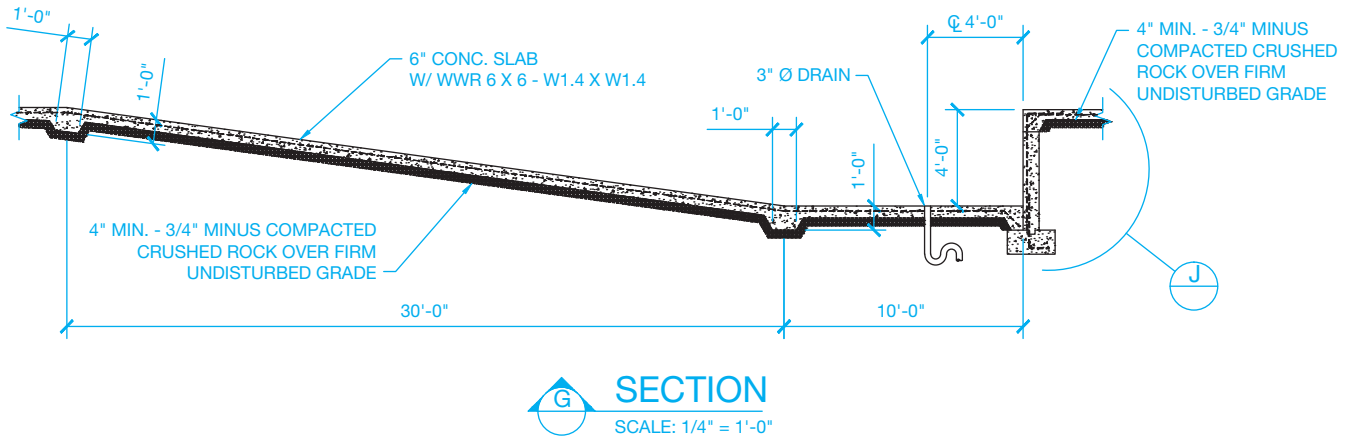
**PROBLEM 22.8** Section E, Slab footing; Section F, Slab joints



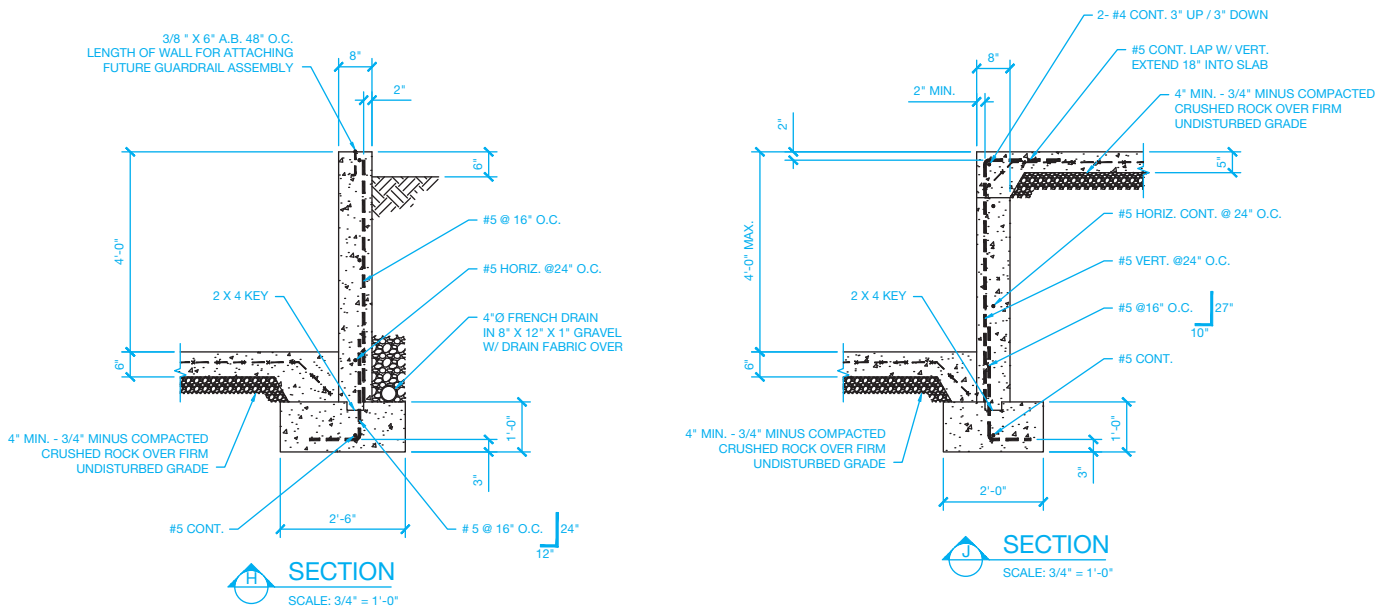
© Cengage Learning 2012



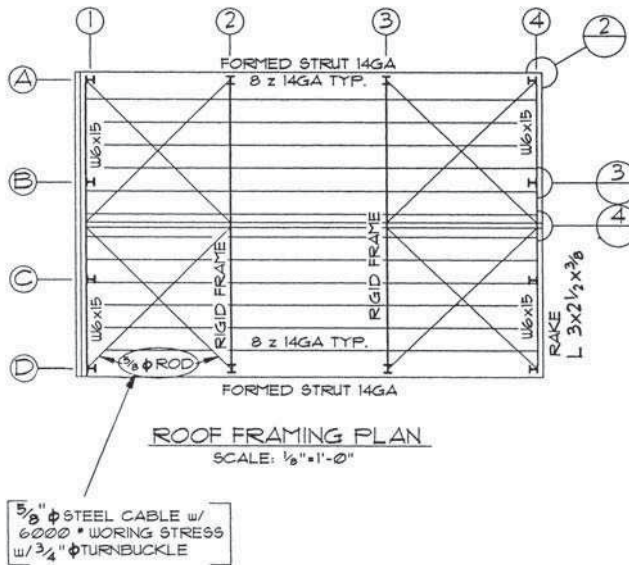
PROBLEM 22.9 Section G, Loading dock ramp



PROBLEM 22.10 Sections H and J, Loading dock walls

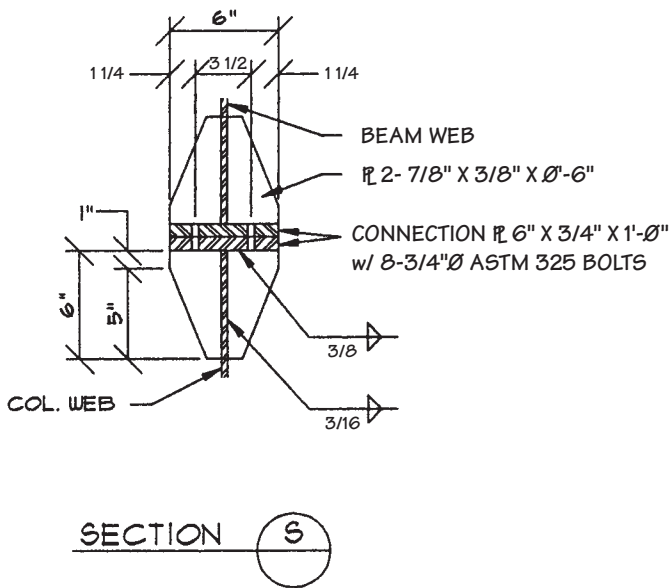
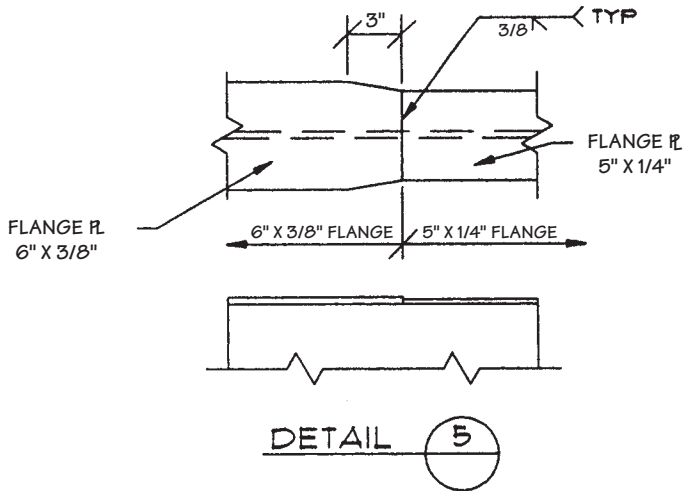


PROBLEM 22.11 Roof framing plan



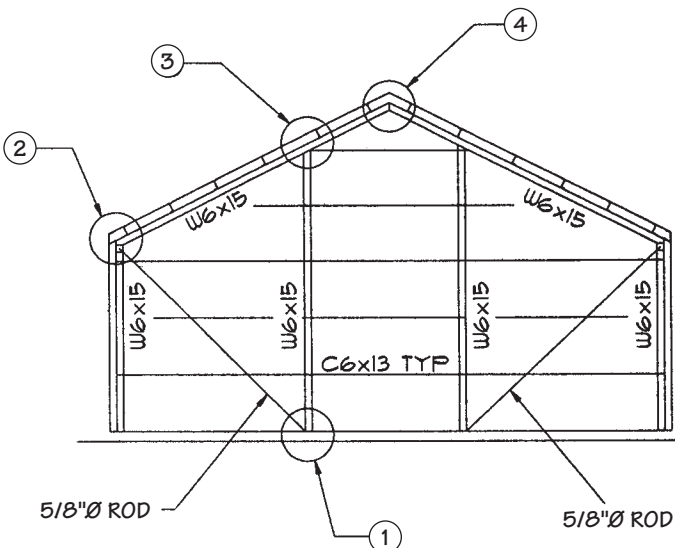


PROBLEM 22.13 Flange details and connections



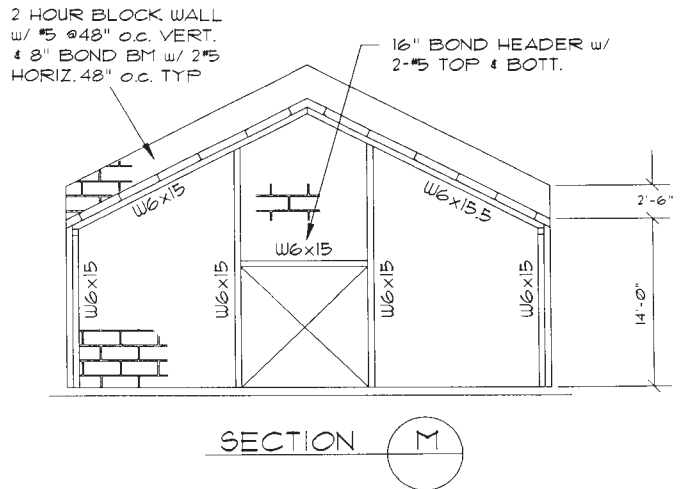
© Cengage Learning 2012

PROBLEM 22.14 End walls



© Cengage Learning 2012

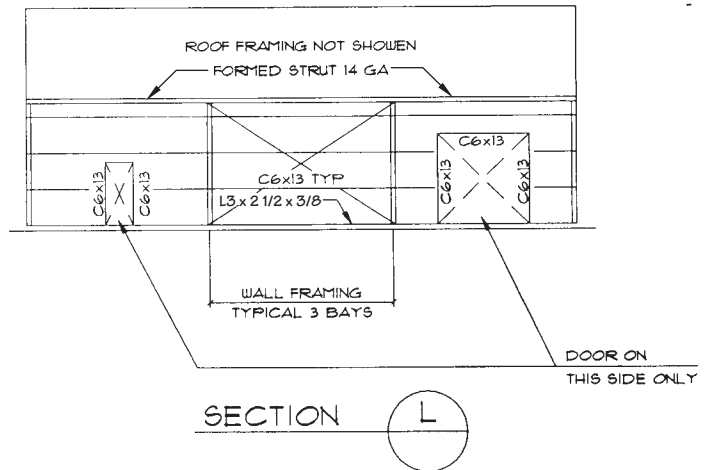
PROBLEM 22.15 Fire walls



NOTE: TYP BLOCK WALL CONN TO BMS & COLS USE 3/4" Ø ANCHOR BOLTS @ 4'-0" o.c.

© Cengage Learning 2012

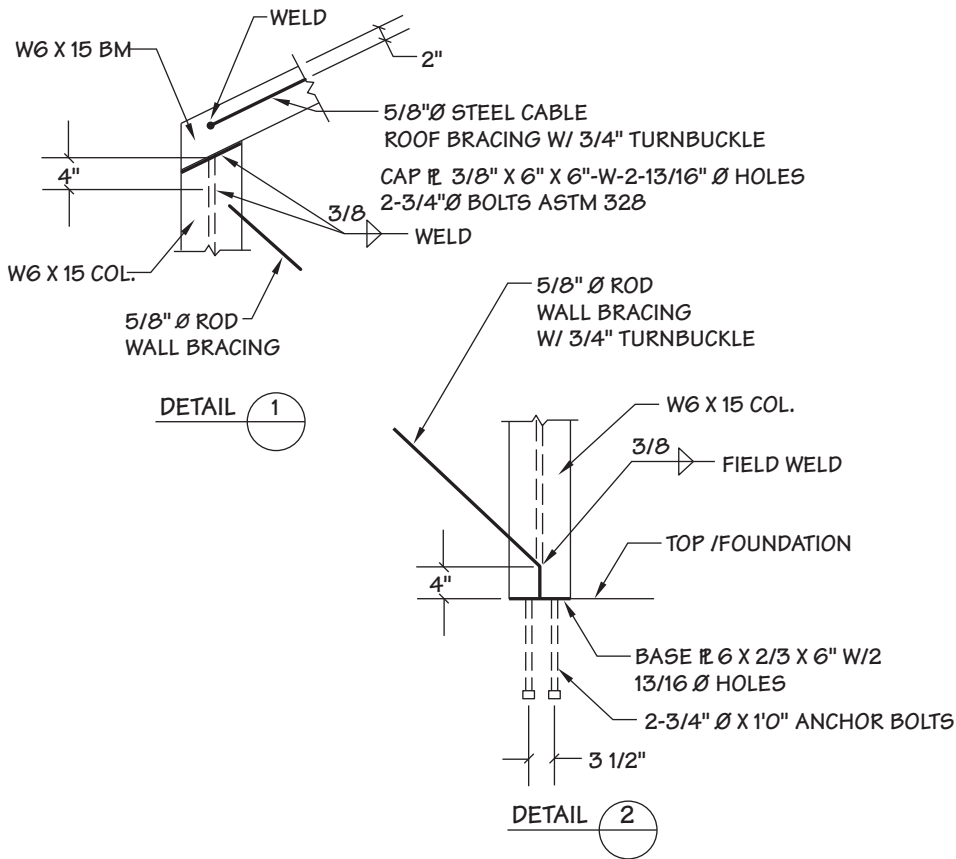
PROBLEM 22.16 Section side wall framing



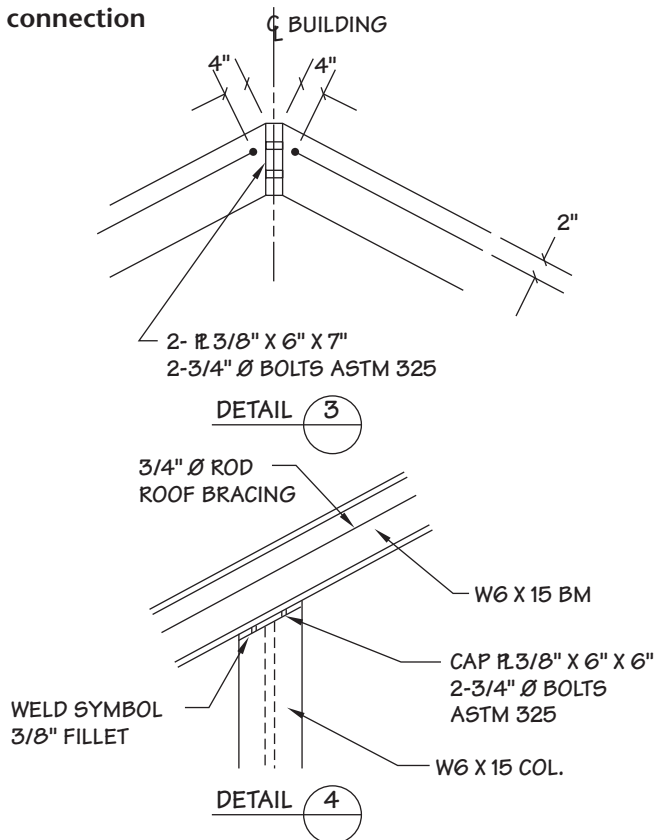
NOTE: DOORS NEED TO BE REVERSED. CONSULT ENGINEER!

© Cengage Learning 2012

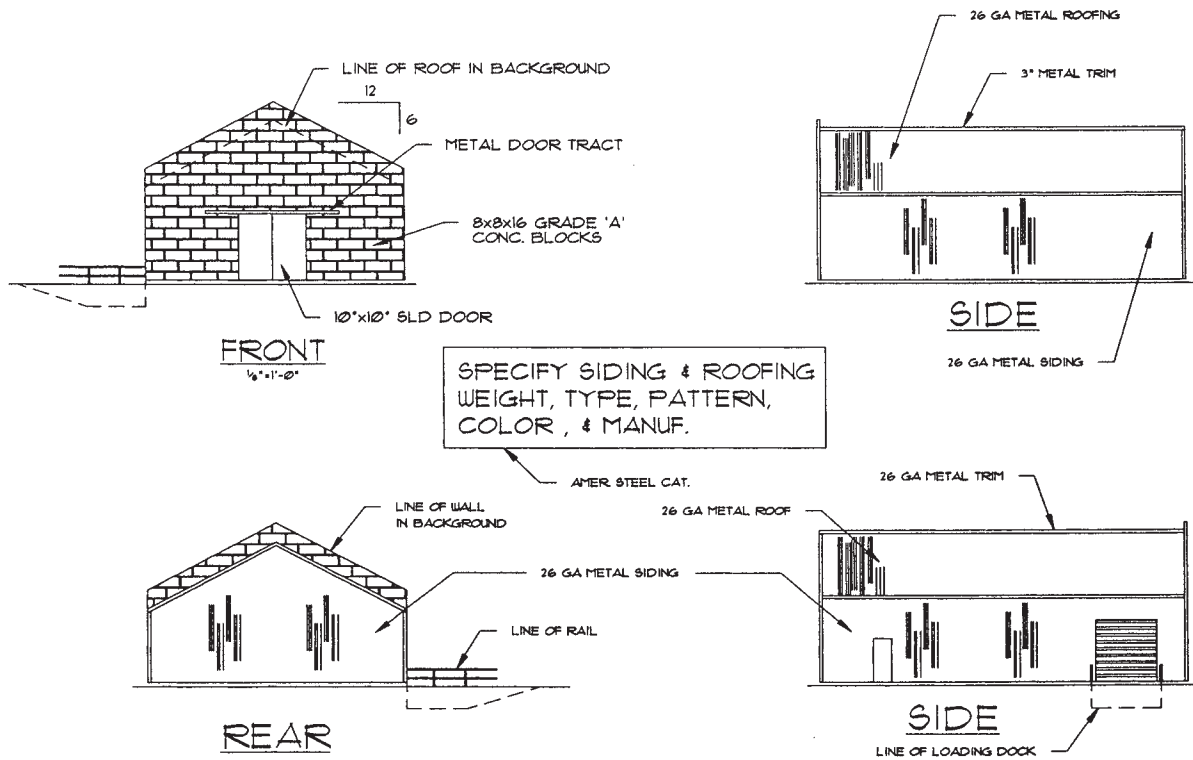
**PROBLEM 22.17** Column base and cap connection details



**PROBLEM 22.18** Column cap and ridge connection details



PROBLEM 22.19 Elevations



© Cengage Learning 2012

Part 3: Problems 22.20 Through 22.25

To access the Chapter 22 problems, go to the Student CD, select **Chapter Tests and Problems** and **Chapter 22**, and then open the problem of your choice or as assigned by your instructor. Solve the problems using the instructions provided on the CD, unless otherwise specified by your instructor.

Math Problems

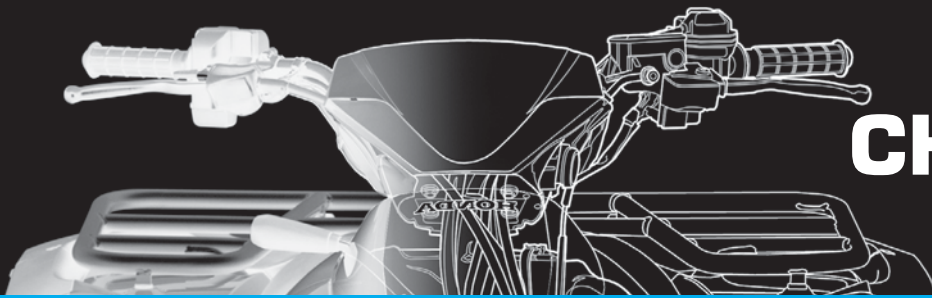
Part 5: Problems 22.27 Through 22.34

To access the Chapter 22 problems, go to the Student CD, select **Chapter Tests and Problems** and **Chapter 22**, and then open the math problem of your choice or as assigned by your instructor. Solve the problems using the instructions provided on the CD, unless otherwise specified by your instructor.

Structural Design Problem

Part 4: Problem 22.26

To access the Chapter 22 problems, go to the Student CD, select **Chapter Tests and Problems** and **Chapter 22**, and then open the problem of your choice or as assigned by your instructor. Solve the problems using the instructions provided on the CD, unless otherwise specified by your instructor.



# CHAPTER 23

## Heating, Ventilating, and Air-Conditioning (HVAC), and Pattern Development

### LEARNING OBJECTIVES

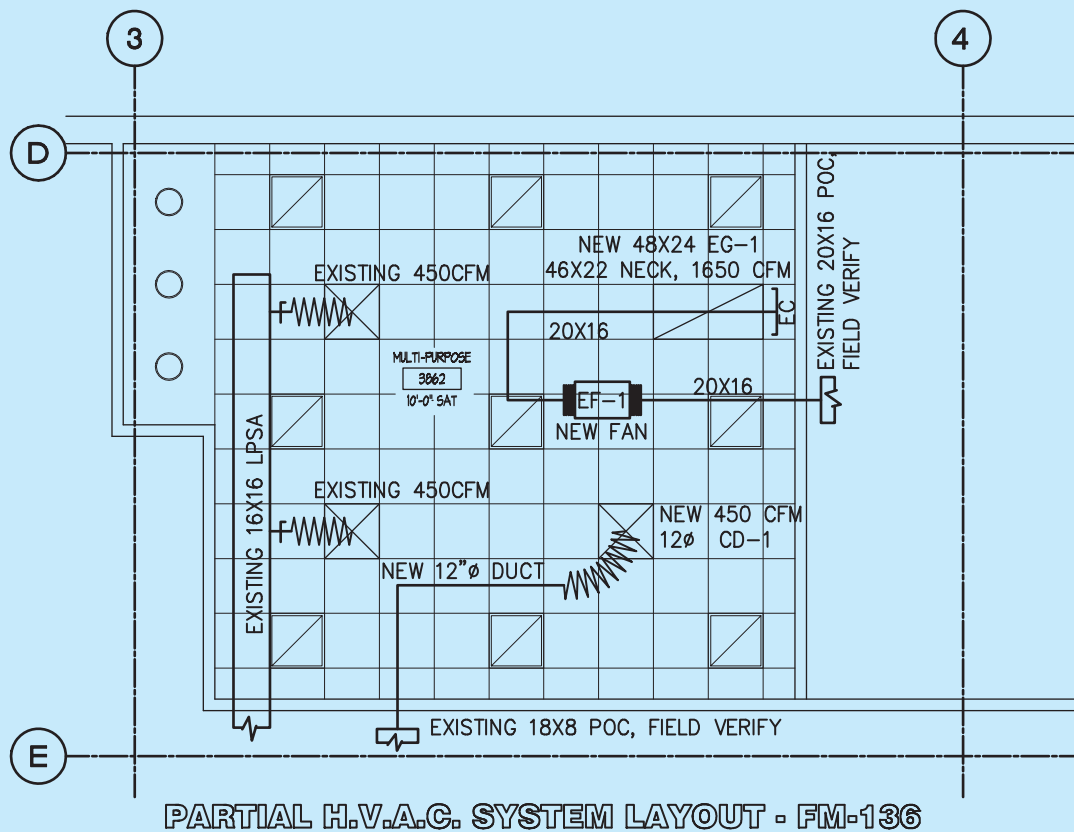
After completing this chapter, you will:

- Discuss the purpose and function of HVAC systems.
- Prepare complete HVAC drawings, including plans, schedules, and details.
- Draw sheet metal pattern developments and intersections.
- Calculate duct sizes based on given CFM and FPM specifications.
- Convert a square or rectangular duct to a round duct and a round duct to a square or rectangular duct.
- Create cut sheets.
- Use an engineering problem as an example for HVAC drawing solutions.

### THE ENGINEERING DESIGN APPLICATION

Your company produces a wide range of sheet metal HVAC ductwork for commercial installations. Your current drawing project is to route a **retrofit** duct system between two

field-measured points of connection (POC), adding a new fan and two air devices. The term *retrofit* means to modify parts or components of the original design to match



**FIGURE 23.1** The completed drawing for the engineering design problem titled FM-136 to indicate this drawing is part of the plan issue for Field Modification number 136.

Courtesy of Brad Dotson, B&D Consulting

characteristics of the structure that may not have been previously known. You must first determine and draft the revised architectural condition for this revised installation, including the revision to the walls, ceiling pattern, and added air devices. You must also determine, through **field verification**, the clearance between the structural elements of the building and the architectural elements of the building to make sure that the new installation is viable. *Field verification* means to go to the construction site and confirm construction by observation and making measurements.

The project manager on the project will provide you with data that allows you to draw the added fan and air devices to scale. You can then develop the shop drawing to be used in the installation of the materials, and you can develop cut sheets showing the needed information for fabrication of the materials in the fabrication plant. Figure 23.1 shows the completed drawing titled FM-136 to indicate this drawing is part of the plan issue for Field Modification number 136.

## INTRODUCTION

This chapter covers two fundamental areas of drafting and design related to sheet metal fabrication. The first content involves the HVAC industry for residential and commercial architecture, engineering, and construction. The HVAC area is followed by pattern development, which involves laying out the geometric sheet metal shapes that are used in HVAC design into their true size and shape flat patterns. These flat patterns are then used in sheet metal fabrication shops to make the fittings used in HVAC construction.

## INTRODUCTION TO HVAC SYSTEMS

**Heating, ventilating, and air-conditioning (HVAC)** systems are made up of mechanical equipment such as the furnace or air-handling unit (AHU), air conditioner, exhaust fan, return or outside air fan, and ductwork. The terms **ductwork** and **duct** generally mean sheet metal pipe designed as the passageway for conveying air from the HVAC equipment to and from the source. Types of duct shapes include cylindrical (pipe), oval, rectangular, and square. Fittings such as elbows and transition shapes that allow for conversion from round to square or rectangular, and size changes and offsets are also used. Any duct shape is possible, depending on the application. In most residential applications, standard premanufactured ductwork is used. In residential and commercial structures, the ductwork can be premanufactured or custom built in a sheet metal fabrication shop. **Flat patterns** are made when custom sheet metal shapes are required. Creating a flat pattern is the process of converting a hollow object into its true flat geometric form. These patterns are made by a sheet metal layout person, or more commonly a computerized layout and cutting system. Flat pattern drawings are referred to as **pattern developments**. CAD/CAM systems are being used to develop the pattern and transfer the pattern to a computerized cutting system, which produces the pattern for each fitting and cuts the pattern out of the sheet metal blank. The pattern is then ready to form into the desired fitting. Most sheet metal shops use this technology.

Other industries also make sheet metal patterns. Whenever flat metal is bent into shape, a sheet metal pattern is required. Examples are auto body parts, storage facilities, and electronics chassis components.

## HVAC SYSTEMS AND COMPONENTS

Most residential and commercial structures have HVAC systems. These systems are also commonly known as **mechanical systems**. The purpose of most heating and air-conditioning systems is to help maintain a normal comfort zone for the occupants living or working in the structure. In other applications, such as meat lockers, the product can be the reason for environmental controls. The function of ventilating systems is to provide air movement or exchange within the structure. Ventilation is required when excess heat, fumes, moisture, odor, or pollutants must be removed and fresh air replaced. Most residential structures do not use HVAC plans unless the system is complex or required by the lending or code enforcement agency. The architect of a commercial or public building usually consults with an HVAC engineer for the design, drafting, and installation supervision of the HVAC system. This consulting engineer is called a **mechanical engineer** after the mechanical system being designed. The consulting engineer prepares the designs and specifications for the project. These designs and specifications, along with the architectural and structural plans and specifications, become the contract documents. The drafter or detailer works from these contract documents. In the case of a very small project, the engineer may prepare rough sketches directly on a copy of the floor plans. This method can be seen on a residential project but is not often used on commercial, institutional, or industrial projects. The HVAC detailer or drafter then creates a new drawing using proper lines, symbols, dimensions, and notes. Companies typically use the American Institute of Architects (AIA) HVAC layer naming systems for the mechanical layers over the base floor plan sheet, creating the HVAC plan. The AIA *CAD Layer Guidelines* established for mechanical HVAC-related CADD layers are described later in this chapter.

## Central Forced-Air Systems

**Central forced-air systems** are among the most common systems for climate heating and air-conditioning—that is, circulating the air from the living spaces through or around heating or cooling devices. A **thermostat** starts the cycle as a fan forces the air into ducts. These ducts connect to openings called **diffusers** or **air supply registers**, which put warm air (WA) or cold air (CA) in

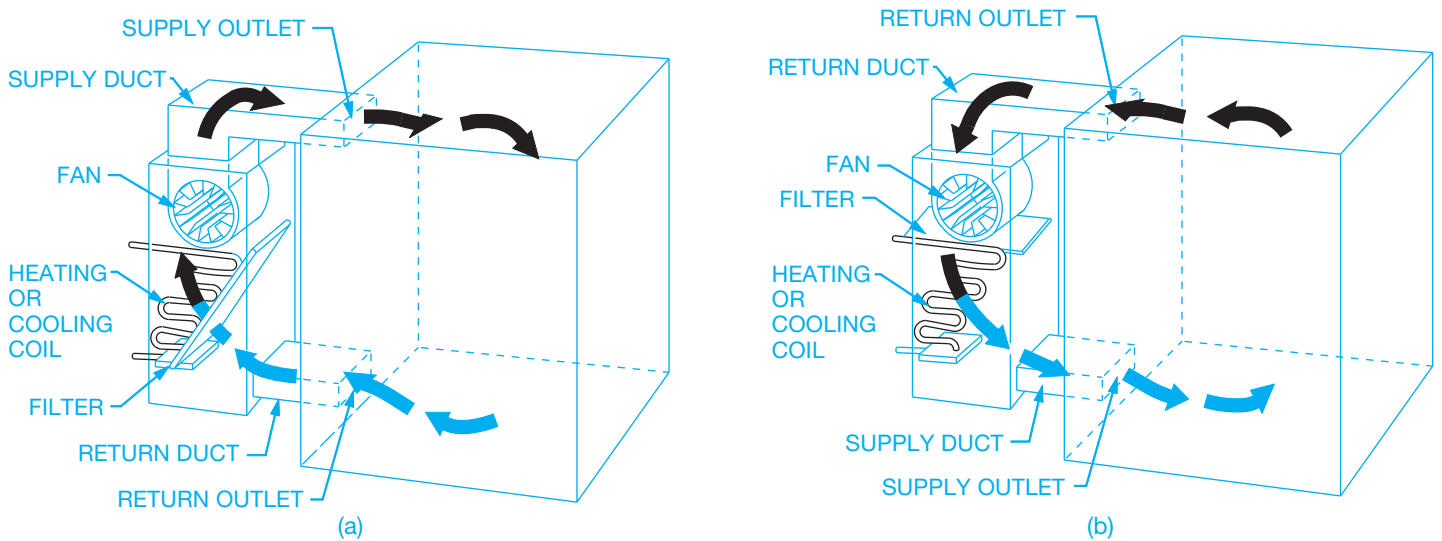


FIGURE 23.2 (a) Downdraft forced-air system air cycle. (b) Updraft forced-air system air cycle. © Cengage Learning 2012

the room. The air enters the room and either heats or cools as needed. Air then flows from the room through another opening called a **return-air (RA) register** and into the return duct. The return duct directs the air from the room over a heating or cooling device, depending on which type is needed. If cool air is required, then the return air is passed over the surface of a cooling coil. If warm air is required, the return air is passed over either the surface of a combustion chamber (the part of a furnace where fuel is burned) or a heating coil. The conditioned air is picked up again by the fan, and the cycle is repeated. Figure 23.2 shows the air cycle in a forced-air system.

### Refrigeration

**Refrigeration** is the most common type of cooling system. Refrigeration is based on the principle that a liquid changing to a vapor absorbs large amounts of heat. The boiling point of a liquid can be altered by changing the pressure applied to the liquid so that a gas gives up heat when it changes to a liquid. The basic parts of a refrigeration system are the cooling coil called the evaporator, the compressor, the condenser where vaporized refrigerant is liquefied, and an expansion valve. Common refrigerants boil at low temperatures. Figure 23.3 is a diagram of the refrigeration cycle.

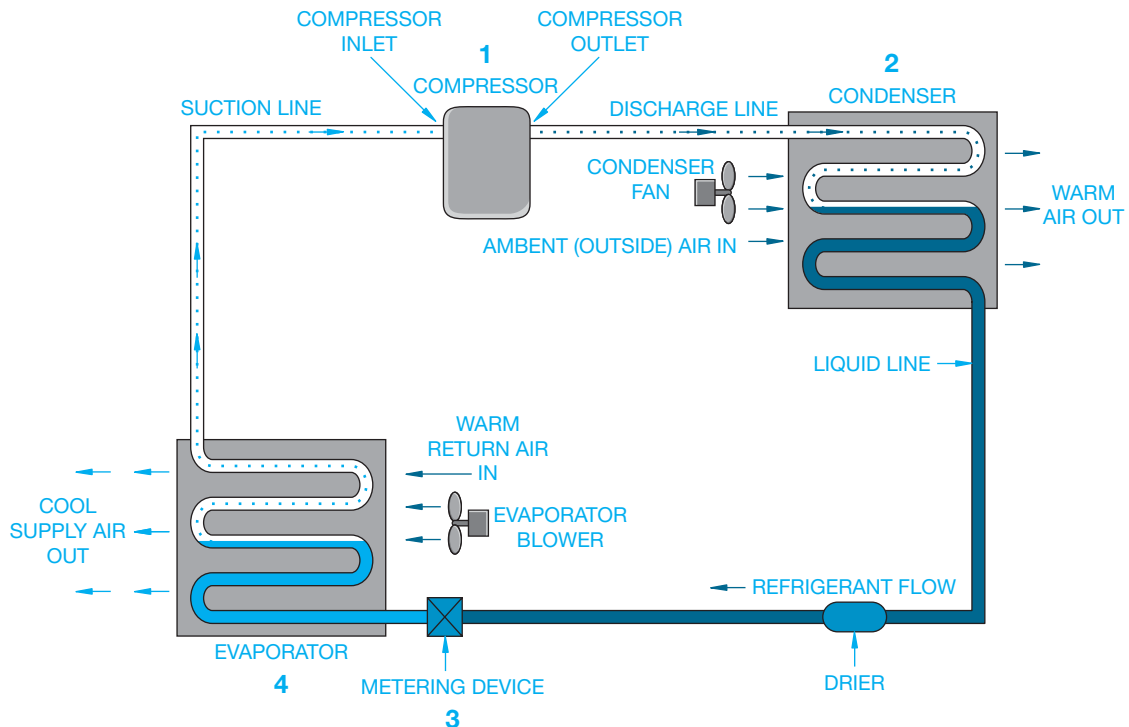


FIGURE 23.3 Air-conditioning circuit and cycle diagram. Image courtesy of Mike Taitano, Air-conditioning-and-refrigeration-guide.com



## Hot-Water System

In a **hot-water system**, water is heated as it circulates around the combustion chamber of a fuel-fired boiler. The water is then circulated through pipes to radiators or convectors in the rooms or to hot-water coils within the HVAC system, which may be located within the equipment or can be duct-mounted coils. In a one-pipe system, hot water leaves the boiler and rises into each radiator at one side with the cooler water falling back in to the single pipe on the opposite side and then back to the boiler as shown in Figure 23.4. With a one-pipe system, the last radiator is always cooler because the water has already given up most of its heat. In a two-pipe system, one pipe supplies heated water to all the outlets, while the other is a return pipe that carries the water back to the boiler for reheating as shown in Figure 23.5.

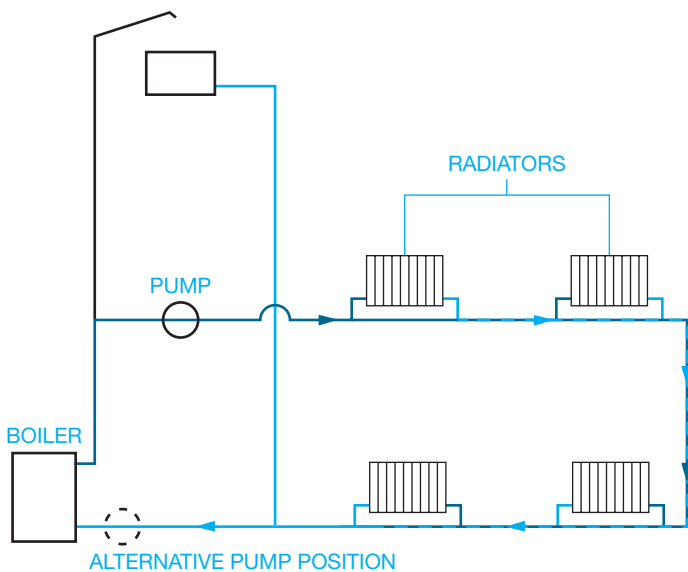


FIGURE 23.4 One-pipe hot-water system. © Cengage Learning 2012

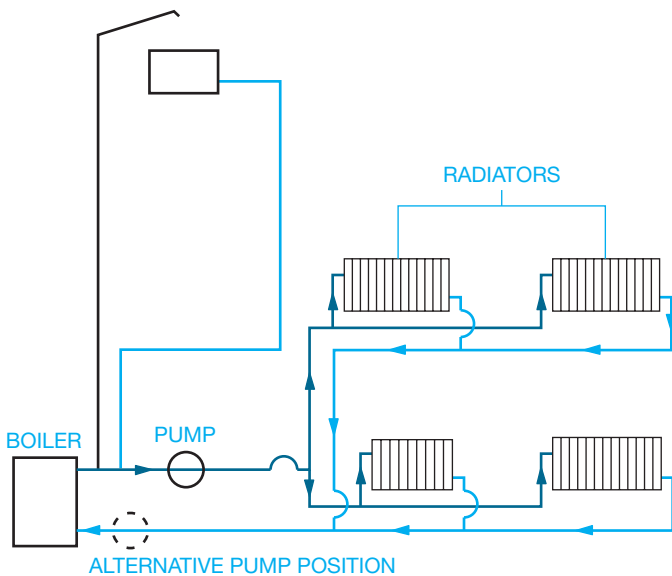


FIGURE 23.5 Two-pipe hot-water system. © Cengage Learning 2012

This method allows for each radiator to have its own circuit. Hot-water systems use a pump called a **circulator** to move the water through the system. The water is kept at a temperature of 150°–180°F (65.5°–82°C) in the boiler. When heat is needed, a thermostat starts the circulator pump.

## Zoned Control System

A **zoned system** allows for one or more heaters and one thermostat per room. No ductwork is required, and only the heaters in occupied rooms need to be turned on. One of the major differences between a zoned and central system is flexibility. A zoned system allows the occupant to determine how many areas are heated and how much energy is used.

Zoned systems are the normal installation in commercial and institutional projects. Zoned systems can be accomplished in a variety of different ways. The most common is with a hot-water or steam system that feeds heating coils within the ductwork or, more commonly, within **terminal units**, which are air valves that have heating coils. Each valve opens and closes based on the heat requirement for that particular terminal unit as determined by the controlling thermostat. Terminal units are also called **variable air volume (VAV)** units.

## Radiant Heat

**Radiant heating and cooling systems** function on the basis of providing a comfortable environment by means of controlling surface temperatures and minimizing excessive air movement within the space instead of attempting to heat the entire volume of air in the space as with hot-air or convective systems. Surface-mounted radiant panels provide comfort by heating the occupant directly at a lower thermostat temperature than other systems. Radiant heating systems are favorable, because there is no dehumidifying of the air and there are no blowers to move dust or viral particles around the heated area. Radiant systems vary from oil or gas hot-water piping in the wall or floor to electric coils, wiring, or panel elements in the ceiling for cooling. Figure 23.6 shows how a typical radiant floor system is installed.

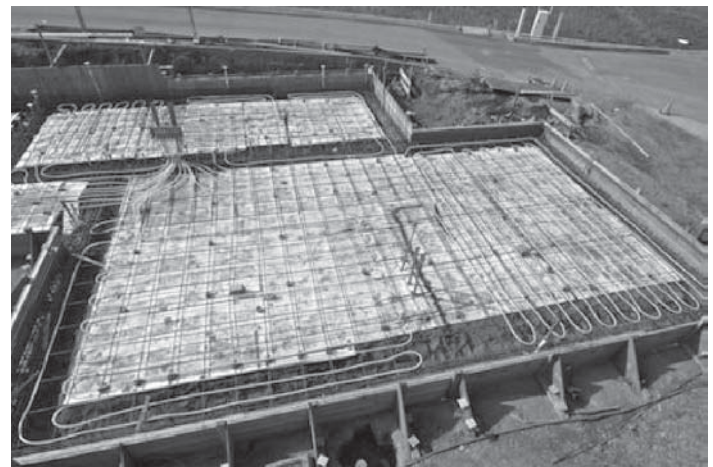
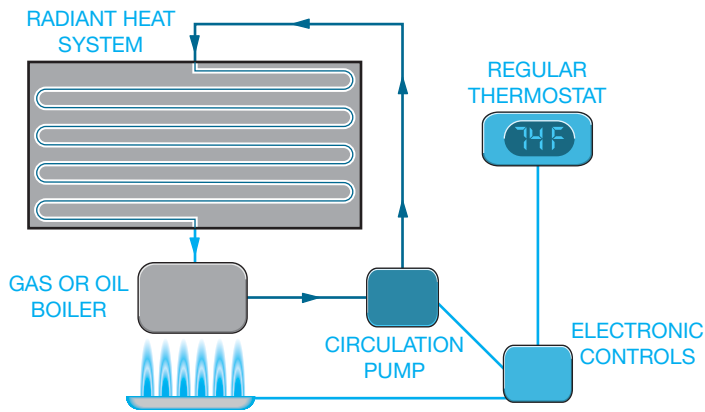


FIGURE 23.6 Radiant floor heating layout. Courtesy Lovesgeothermal.com/solarpanelsplus



**FIGURE 23.7** Hydronic radiant heating, conventional topology. Courtesy [Lovesgeothermal.com/solarpanelsplus](http://Lovesgeothermal.com/solarpanelsplus)

Figure 23.7 shows the process of a **hydronic radiant heating** system. Hydronic radiant floor heating is a system of plastic or metal tubes and pipes laid within a floor that carries hot water into specific rooms or zones, dispersing the heat through the floor surface. A radiant heating system can be combined with solar as shown in Figure 23.8, further reducing energy costs. Radiant heating and cooling is quickly becoming an expected and dominant part of **Leadership in Energy and Environmental Design (LEED)** and is being used by many architects and engineers in the design process for small and large commercial and retail construction. LEED is an internationally recognized green building certification system that provides third-party verification that a building or community was designed and built using strategies aimed at improving performance in areas such as energy savings, water efficiency, CO<sub>2</sub> emissions reduction, improved indoor environmental quality, and stewardship of resources and sensitivity to their impacts. LEED was developed by the U.S. Green Building Council (USGBC). LEED is described further in this chapter and other construction-related chapters.

## Heat Pump System

The **heat pump** is a forced-air central heating and cooling system that operates using a compressor and a circulating liquid-gas refrigerant and work best in moderate climates. Heat is extracted from the outside air and pumped inside the structure. The heat pump supplies as much as three times the heat per year for the same amount of electrical consumption. A standard electrical forced-air heating system works best when outside air is above 20°F. In the summer, the cycle is reversed and the unit operates as an air conditioner. In this mode, the heat is extracted from the inside air and pumped outside. On the cooling cycle, the heat pump also acts as a dehumidifier. Figure 23.9 shows how a heat pump works.

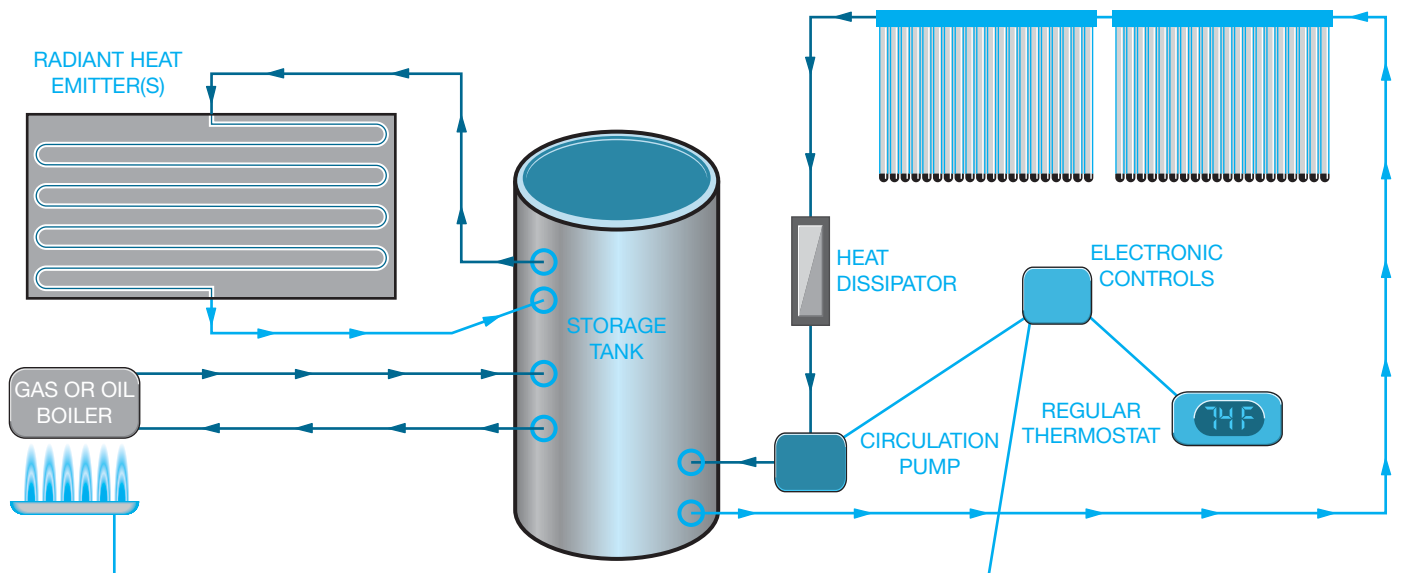
## Ventilation

There are a number of reasons why ventilation of a structure or area is necessary. Residential applications include bath, kitchen, and laundry exhaust fans. In commercial applications, ventilation can be necessary to exhaust fumes, pollutants, or moisture and to introduce outside or fresh air into the conditioning system.

## Sources of Pollutants

There are a number of sources of pollutants that make it necessary to plan ventilation systems. **Moisture** in the form of relative humidity can cause structural damage and health problems such as respiratory troubles and microbial growth. Each individual can produce up to one gallon of water vapor per day.

**Indoor combustion** from such items as gas-fired or wood-burning appliances and fireplaces can generate a variety of pollutants, including carbon monoxide and nitrogen oxides.



**FIGURE 23.8** Solar heating integrated with radiant system.

Courtesy Lovesgeothermal.com/solarpanelsplus

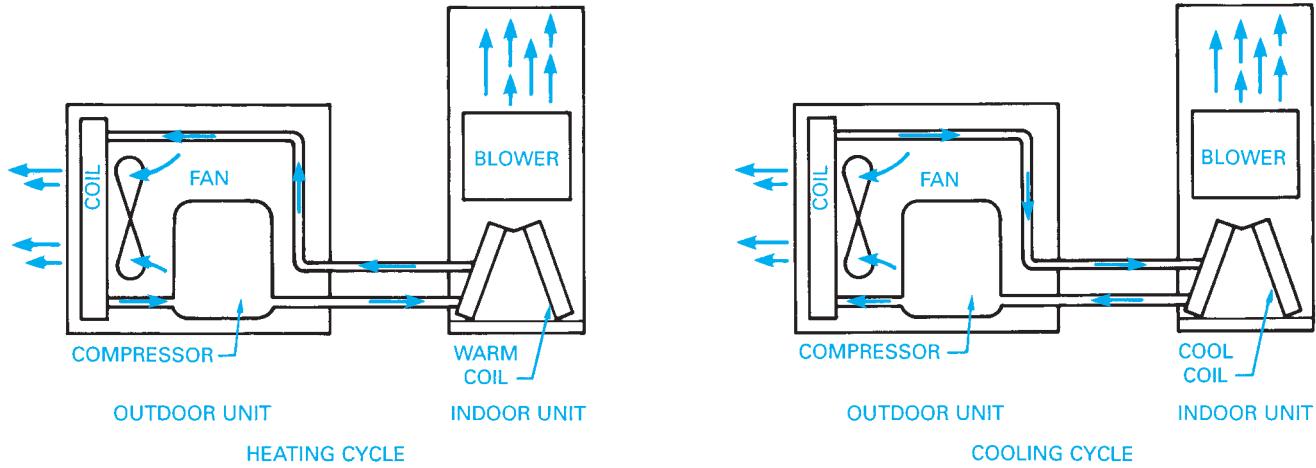


FIGURE 23.9 Heat pump heating and cooling cycle. Courtesy Lennox Industries, Inc.

Humans and pets can transmit diseases through the air by exhaling a variety of bacterial and viral contaminants.

**Tobacco smoke** can contribute chemical compounds to the air environment. The pollution can affect smokers and nonsmokers.

**Formaldehyde** in glues used in construction materials such as plywood, particleboard, and even carpet and furniture causes pollution, as do the components of certain insulations. Formaldehyde has been considered a factor in certain diseases, eye irritation, and respiratory problems.

**Radon** is a naturally occurring radioactive gas that breaks down into compounds that can cause cancer when large quantities are inhaled over a long period of time. Radon can be more apparent in a structure that contains a great deal of concrete or is located in certain geographic areas of the country. Radon can be scientifically monitored at a nominal cost. Barriers can be built that help reduce the concern of radon contamination.

Household products such as aerosols and crafts materials such as glues and paints can contribute a number of toxic pollutants.

### Air-to-Air Heat Exchangers

The **air-to-air heat exchanger** is a heat-recovery ventilation device that pulls stale and polluted warm air from the living or working space through a duct system and transfers the heat in the air to the fresh cold air being pulled into the structure. The transferred air is then mixed with return air and introduced back into the conditioning system. Heat exchangers do not produce heat. Heat exchangers only move heat from one airstream to the other. The heat transfers to the fresh airstream in the core of the heat exchanger. The core is usually designed to avoid mixing the two airstreams to ensure that indoor pollutants are removed. Moisture in the stale air condenses in the core and is drained from the unit. Figure 23.10 shows the basic components and function of an air-to-air heat exchanger. Knowledgeable mechanical engineers, designers, and contractors are able to implement air-to-air heat exchanger technology by the selection of the proper size of a ducted system.

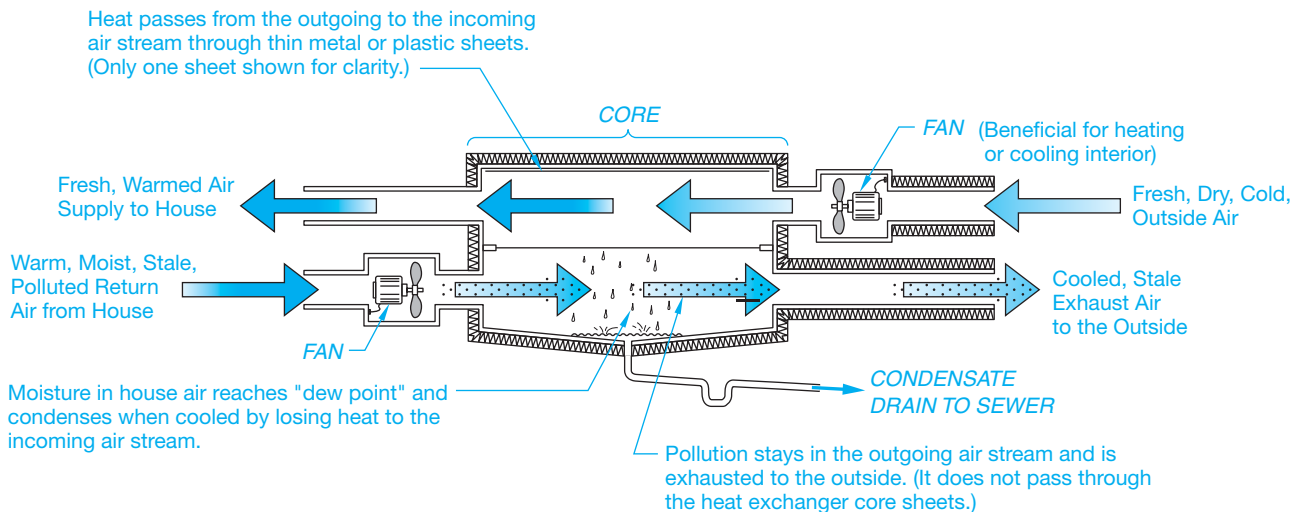


FIGURE 23.10 Components and function of an air-to-air heat exchanger. Courtesy U.S. Department of Energy

## Thermostat

The thermostat is an automatic mechanism for controlling the amount of heating or cooling given by a central or zoned heating or cooling system. The thermostat symbol is shown in Figure 23.11.

The location of the thermostat is an important consideration to the proper functioning of the system. For zoned units, there may be thermostats placed in each room or a central panel



FIGURE 23.11 Thermostat floor plan symbol.

placed in a convenient location. For central systems, there may be one or more thermostats depending on the layout of the system or the number of units required to service the structure. For example, an office complex may have a split system in which the structure is divided into two or more zones. Each individual segment of the system has its own thermostat.

Several factors contribute to the effective placement of the thermostat for a central system. A good common location is near the center of the structure and close to a return-air duct. The air entering the return-air duct is usually temperate, thus causing little variation in temperature. This is a location where an average temperature reading can be achieved. There should be no drafts. Avoid locations where sunlight or a heat register could cause an unreliable reading. Avoid placement near an exterior opening or on an outside wall. Avoid placement near stairs or a similar traffic area where significant bouncing or shaking could cause the mechanism to alter the actual reading.

## GREEN TECHNOLOGY APPLICATION

### GREEN TECHNOLOGY

First, you should understand **green technology** before comparing it to HVAC and how the HVAC industry works to make equipment and designs green technology friendly. Green technology uses evolving technology to utilize methods and materials to develop techniques that are friendly or friendlier to the environment than past methods and material. HVAC is constantly evolving as new ideas about environmentally friendly concepts are put into place and used to make things more efficient and friendly to the environment. It has become necessary for many people and industries to stop ignoring environmental concerns because using older methods costs more to implement than the new methods. The definition of green technology goes a little further in implementing a solid strategy of environmentally friendly ideas, methods, and materials including machines. These strategies include sustainability, cradle-to-cradle design, and source reduction.

### Sustainability

**Sustainability** is the conservation of natural resources. HVAC is a constantly evolving industry, and many manufacturers work to make their equipment more and more efficient. The research-and-development budgets of many large HVAC manufacturers lead the way. This research is supplemented by the U.S. Department of Energy and large industrial manufacturers related to HVAC. For example, Alcoa is a large producer of aluminum from raw materials and through recycling. Alcoa has sponsored research into better heat exchangers using aluminum materials. All these factors improve HVAC and contribute to sustainability in green technology.

### Cradle-to-Cradle Design

**Cradle-to-cradle design** means designing products that can be fully reclaimed or recycled into new products at the end of their life cycles. Almost everything in HVAC equipment can be recycled or reclaimed at the end of its life, including refrigerant used in HVAC equipment. In fact, some of the components used in air-conditioning and heating equipment have a high recycling value at the end of its life, especially the coils used in condensers and evaporators.

### Source Reduction

**Source reduction** is the reduction of waste and pollution by changing methods of production and energy consumption in order to help conserve energy and help the environment. In HVAC, the development of **smart HVAC systems** is helping source reduction by controlling the equipment to a more precise degree than ever before. The HVAC industry has designed equipment and controls for the equipment so that the equipment only uses the amount of energy needed to meet the current demand. Energy is saved by using methods like staging and equipment that can modulate its output in accordance with what is exactly needed.

### HIGH-PERFORMANCE HVAC AND GREEN TECHNOLOGY

High-performance HVAC and green technology work together through innovation and viability.

## Innovation

**Innovation** provides developments in alternate technologies that do not harm the environment or decrease the use of fossil fuels and chemicals that have been known to harm the environment and human beings. The HVAC industry is constantly working on new innovations that reduce the use of fossil fuels and harmful chemicals. The recent change in the use of **chloro-fluorocarbon (CFC)** refrigerants and the planned phase out of **hydrochlorofluorocarbons (HCFCs)**, replacing those refrigerants with CFCs, is a good example of this process. In addition, the design of new gas and oil boilers and furnaces that have maximum efficiencies contributes to this part of green technology. CFC is a fluorocarbon with chlorine. CFC was used as a refrigerant and as a propellant in aerosol cans. The chlorine in CFCs depletes atmospheric ozone. Hydrochlorofluorocarbon is a fluorocarbon that is replacing chlorofluorocarbon as a refrigerant and propellant in aerosol cans.

## Viability

**Viability** means making green technology economically feasible and creating jobs and careers around green technology that truly help protect the environment and our planet. From the people who work in the research-and-development labs to the people who work in inspecting and commissioning new buildings the HVAC industry has many people employed and contributing to green technology.

The HVAC industry has evolved out of necessity into green technology simply because the cost of energy has risen in the last few decades to make the HVAC industry produce equipment that is more efficient and uses less energy to maintain comfortable temperatures. This benefits the environment in a big way by helping to protect our environment. It is all about using finite resources in a wise manner.

Green Technology Application courtesy of Richard Answorth, [www.highperformancehvac.com](http://www.highperformancehvac.com)

## HVAC SYMBOLS

### STANDARDS

ANSI Standard symbols adopted by ANSI are available in the document *Graphical Symbols for Heating, Ventilating, and Air Conditioning*, ANSI Y32.2.4. Standard symbols are often modified to fit individual needs, with a legend placed on a separate sheet in the drawing package for interpretation.

More than 100 HVAC symbols can be used in residential and commercial heating plans, although only a few are typically used in residential HVAC drawings. Most engineering firms tend to use standard HVAC symbols with only minor modifications when generating contract documents. However, when developing shop and installation drawings, engineering firms commonly use their own symbols. Symbols can vary widely from contractor to contractor. You probably will not see many standard symbols on contractors' drawings. Symbols are divided into heating, ventilating, and air-conditioning categories. Figure 23.12 shows some common HVAC symbols. Line symbols are also commonly used in HVAC drafting to represent related piping. These line symbols are commonly solid or dashed lines when used on single-line drawings. The single-line symbols are broken periodically with an abbreviation inserted in the break. On double-line drawings, the symbols might be placed between or next to the lines. The abbreviation identifies the pipe application as shown in Figure 23.12. Sheet metal conduit (duct) and air-conditioning CADD templates are available to help speed drafting, and CADD menus and symbols libraries are used to customize drafting practices.

## HVAC DRAWINGS

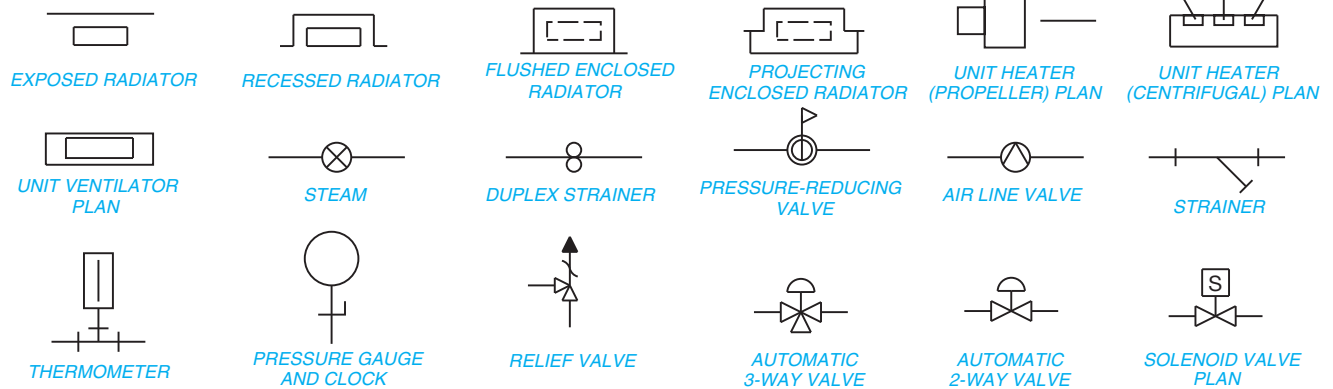
Drawings for the HVAC system show the size and general location of all equipment, ductwork, and components with accurate symbols, specifications, notes, and schedules that form the basis of contract requirements for construction. Specifications are documents that accompany the drawings and contain all pertinent written information related to the fabricated and purchased components of the HVAC system.

When a complete HVAC layout is necessary, drawings can be prepared by the mechanical engineer, architect, architectural drafter, or heating contractor. Figure 23.13 shows a heating plan for a residential structure. Because of the complexity of HVAC systems, especially because the systems now are **dual purpose**, the layout is always prepared by a mechanical engineer rather than an architect. *Dual purpose* means that the HVAC systems are used for their intended purpose and for life safety. Virtually all commercial and institutional buildings designed today have a **life safety system** built into the HVAC system that closes off certain parts of the building in the event of a fire and provides additional ventilation and smoke exhaust in the life safety exit paths. This is an area of expertise that the architect generally does not design. Some architectural firms have their own mechanical engineering departments, but it is still a mechanical engineer who does the HVAC design.

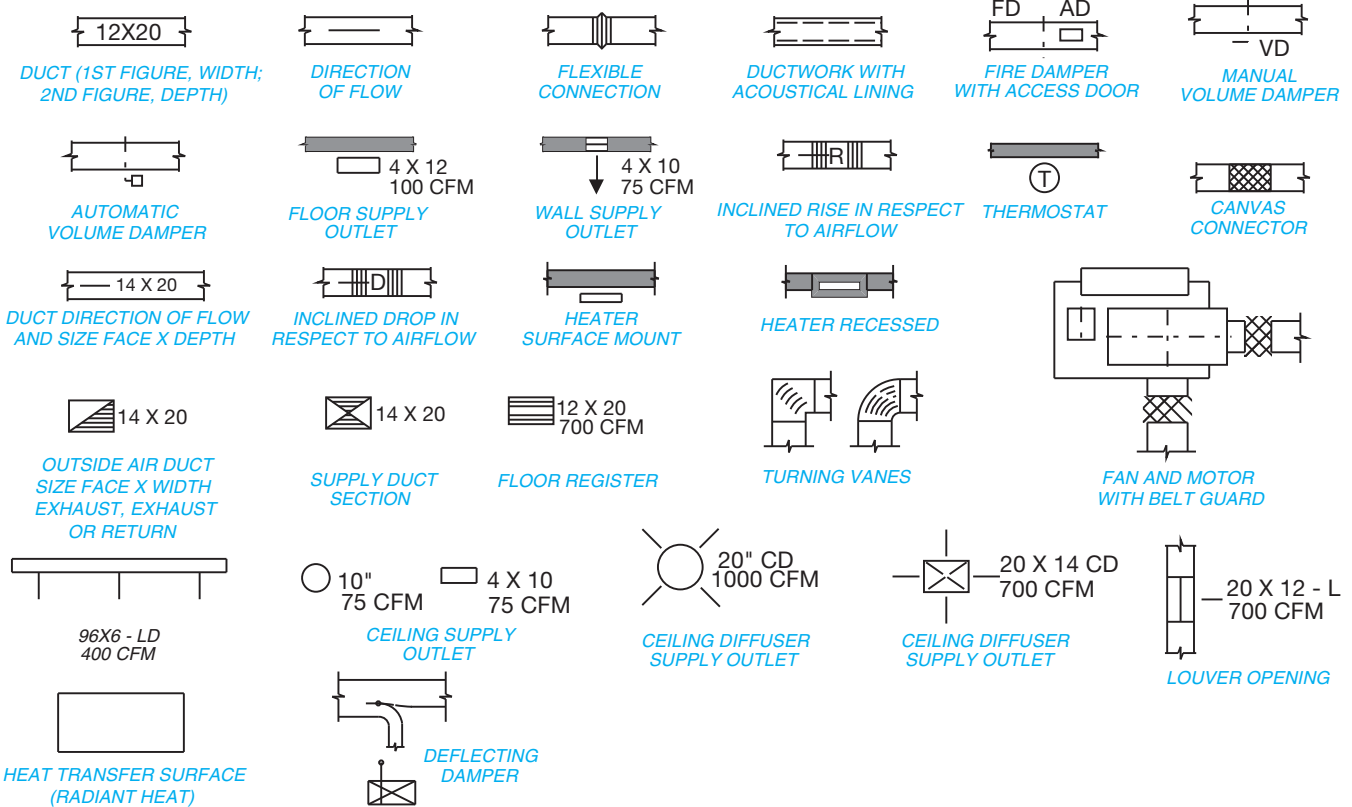
## Creating an HVAC Contract Drawing from an Engineering Sketch

For commercial structures, the HVAC plan is usually prepared by a mechanical engineer as a consultant for the architect as previously discussed. The consulting engineer is responsible

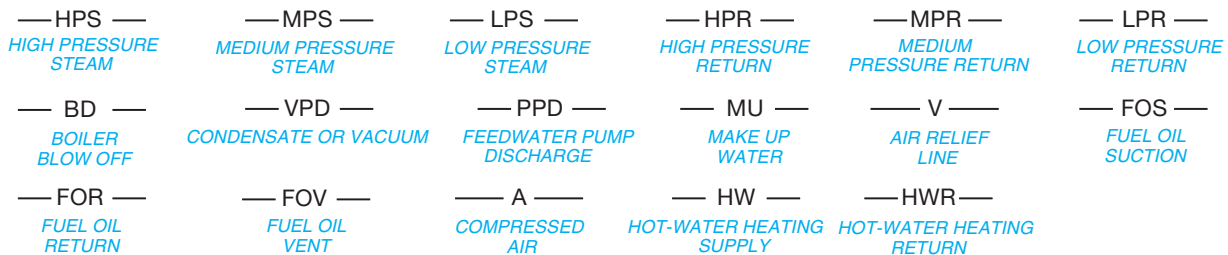
**EQUIPMENT SYMBOLS**



**DUCTWORK**



**HEATING PIPING**



**FIGURE 23.12** Common HVAC symbols.

**AIR-CONDITIONING PIPING**

— RL — REFRIGERANT LIQUID	— RD — REFRIGERANT DISCHARGE	— RS — REFRIGERANT SUCTION	— CWS — CONDENSER WATER SUPPLY	— CWR — CONDENSER WATER RETURN	— CHWS — CHILLED WATER SUPPLY
— CHWR — CHILLED WATER RETURN	— MU — MAKE UP WATER	— H — HUMIDIFICATION LINE	— D — DRAIN		

**REFRIGERATION SYMBOLS**

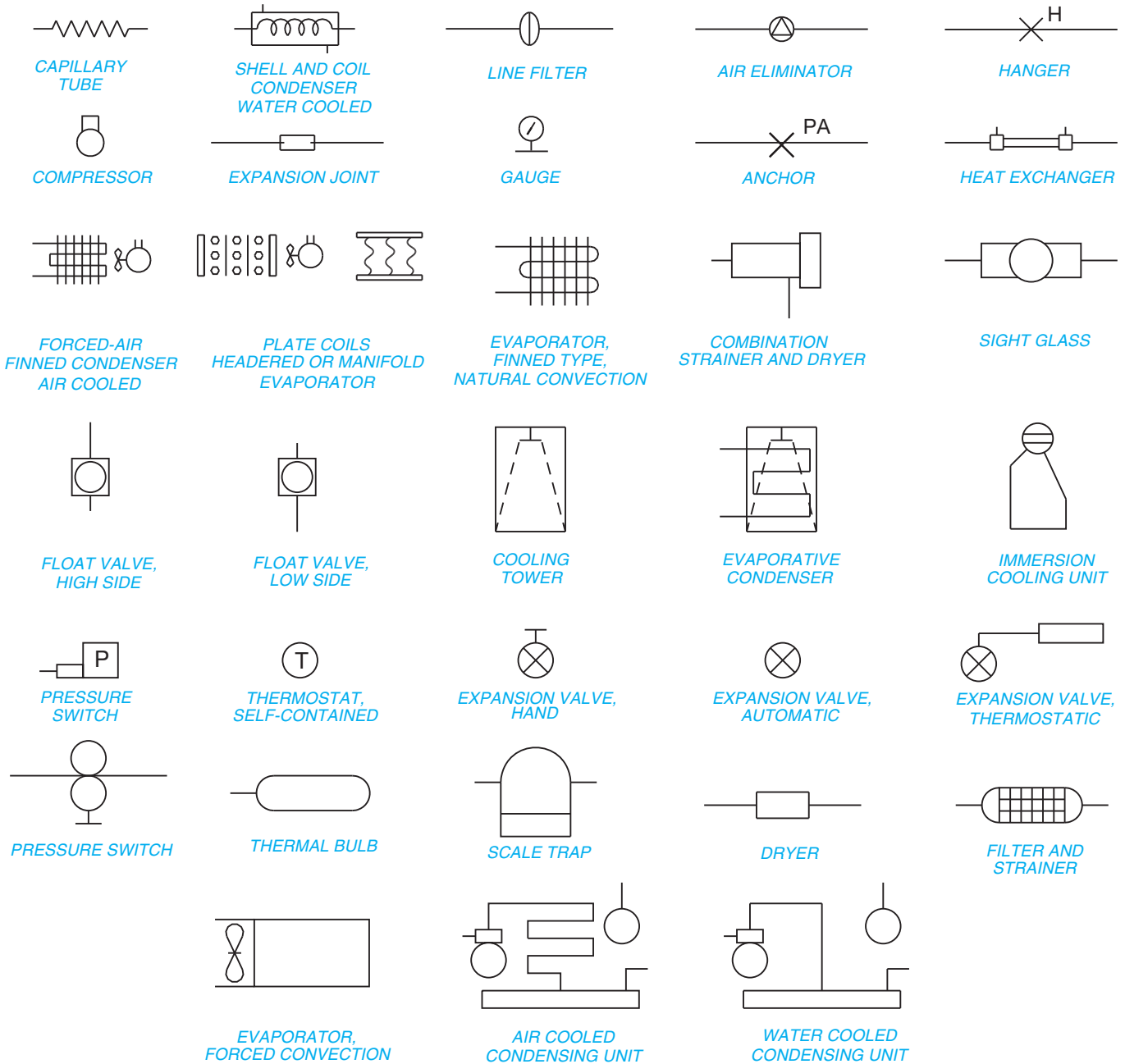
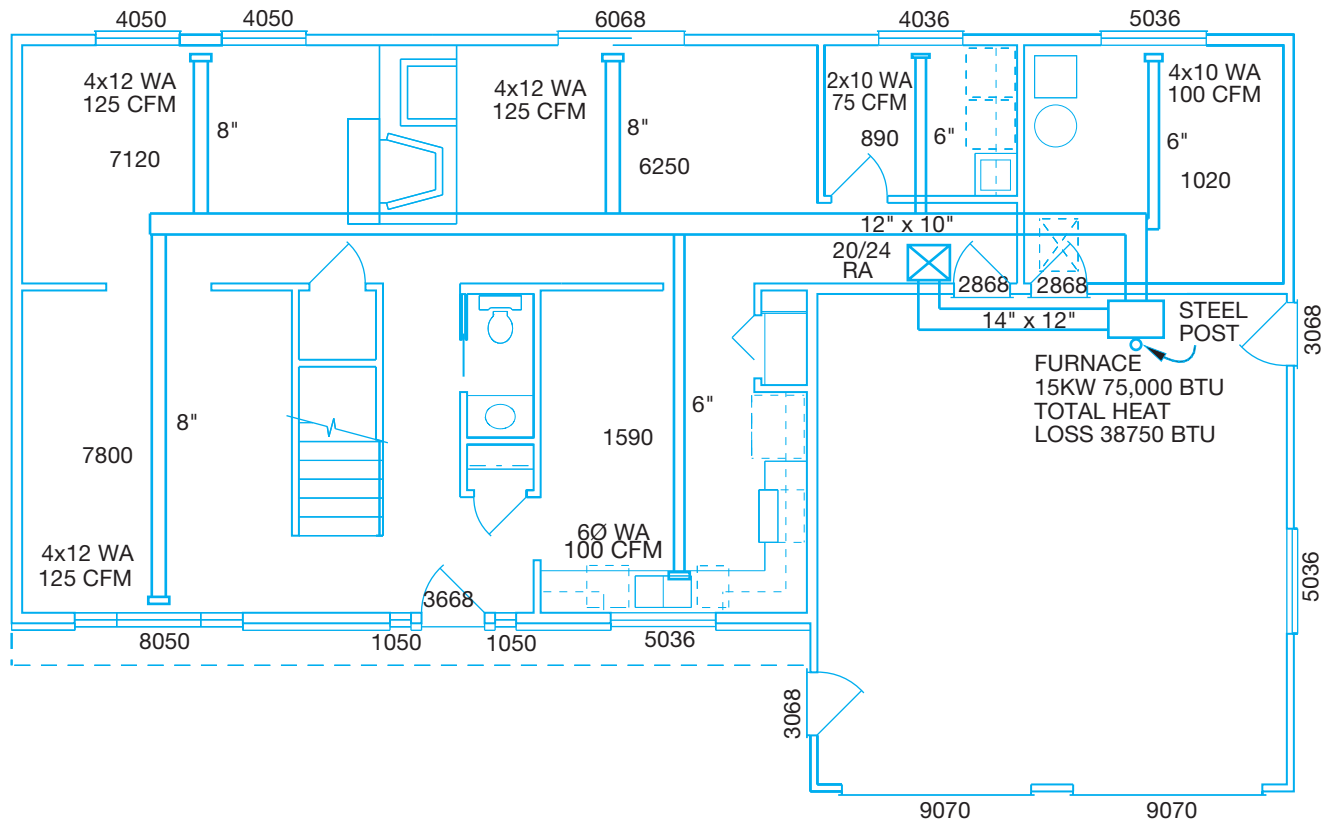


FIGURE 23.12 (Continued)



© Cengage Learning 2012

FIGURE 23.13 A detailed forced-air plan for a residential structure.

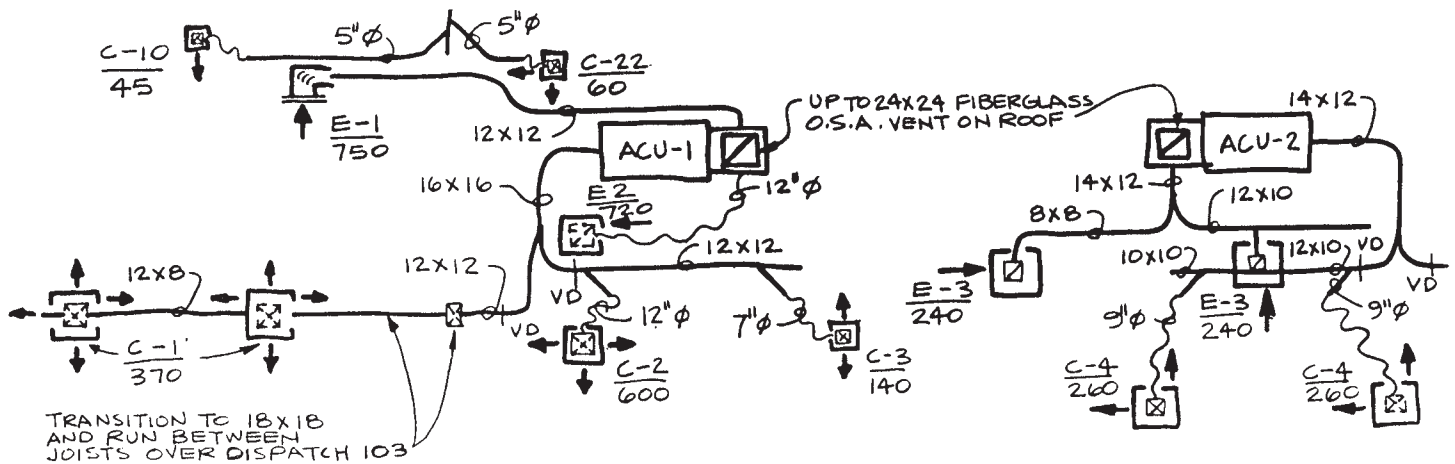


FIGURE 23.14 Single-line HVAC engineer's sketch. © Cengage Learning 2012

for the HVAC design and installation. The engineer determines the placement of all equipment and the general location of all duct runs and components. The engineer also determines all of the specifications for unit and duct size based on calculations of structure volume, exterior surface areas and construction materials, rate of airflow, and pressure. The engineer can prepare single-line sketches or submit data and calculations to a design drafter who prepares design sketches or final drawings.

Drafters without design experience work from engineering or design sketches to prepare formal drawings. A single-line engineer's sketch is shown in Figure 23.14. The next step in the HVAC design is for the drafter to convert the rough sketch into a preliminary drawing. This preliminary drawing goes back to the engineer and architect for verification and corrections or changes. The final step in the design process is for the drafter to apply the design changes on the preliminary drawing to



establish the final HVAC drawing. The final HVAC contract drawing is shown in Figure 23.15a. The HVAC contract drawing is the drawing or set of drawings for the HVAC system based on the building construction contract. Contract documents were described earlier in this chapter.

Convert an engineering sketch to a formal contract drawing using the following steps.

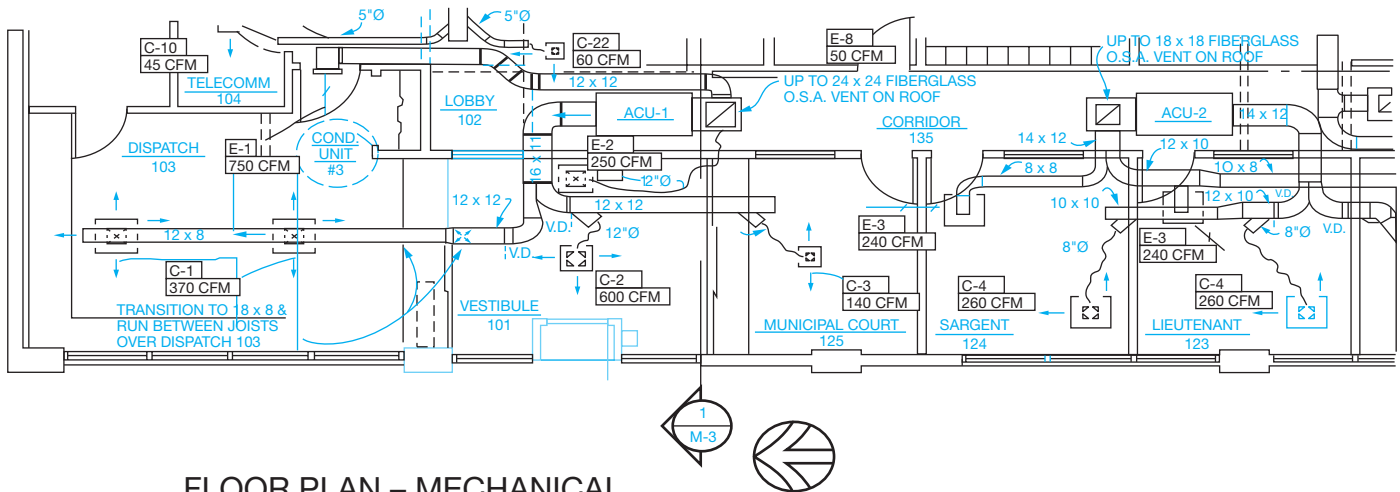
- STEP 1** Draw duct runs using thick .03 or .035 in. (0.7 or 0.9 mm) line widths.
- STEP 2** Label duct sizes within the duct when appropriate or use a note with a leader to the duct in other situations.

**STEP 3** Duct sizes can be noted as 22 × 12 (560 × 300 mm) or 22/12, where the first number, 22, is the duct width, and the second numeral, 12, indicates the duct depth.

**STEP 4** Place notes on the drawing to avoid crowding. Aligned dimensioning can be used where horizontal notes read from the bottom of the sheet and vertical notes read from the right side of the sheet. Make notes clear and concise.

**STEP 5** Refer to schedules to get specific drawing information that is not otherwise available on the sketch.

**STEP 6** Label equipment either blocked out or bold to clearly stand out from other information on the drawing



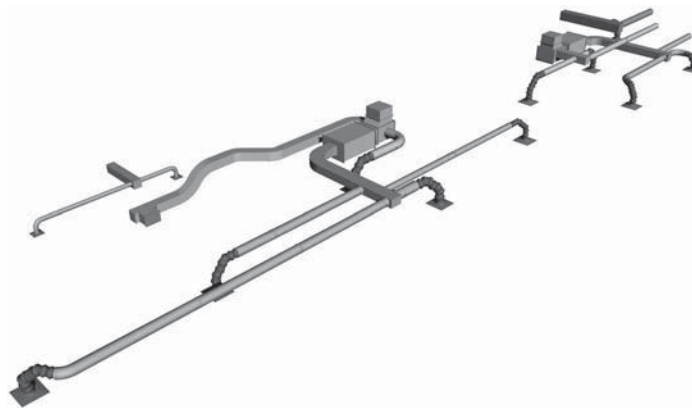
**FLOOR PLAN – MECHANICAL**

SCALE: 1/4" = 1"-Ø"

**GENERAL NOTES:**

- ① VERIFY ALL EXISTING CONDITIONS AT SITE.
- ② SEE ARCHITECTURAL FLOOR PLAN FOR 1-HR RATED AREAS. PROVIDE FIRE DAMPERS AS SCHEDULED AND AS REQ'D BY CODE.

(a)

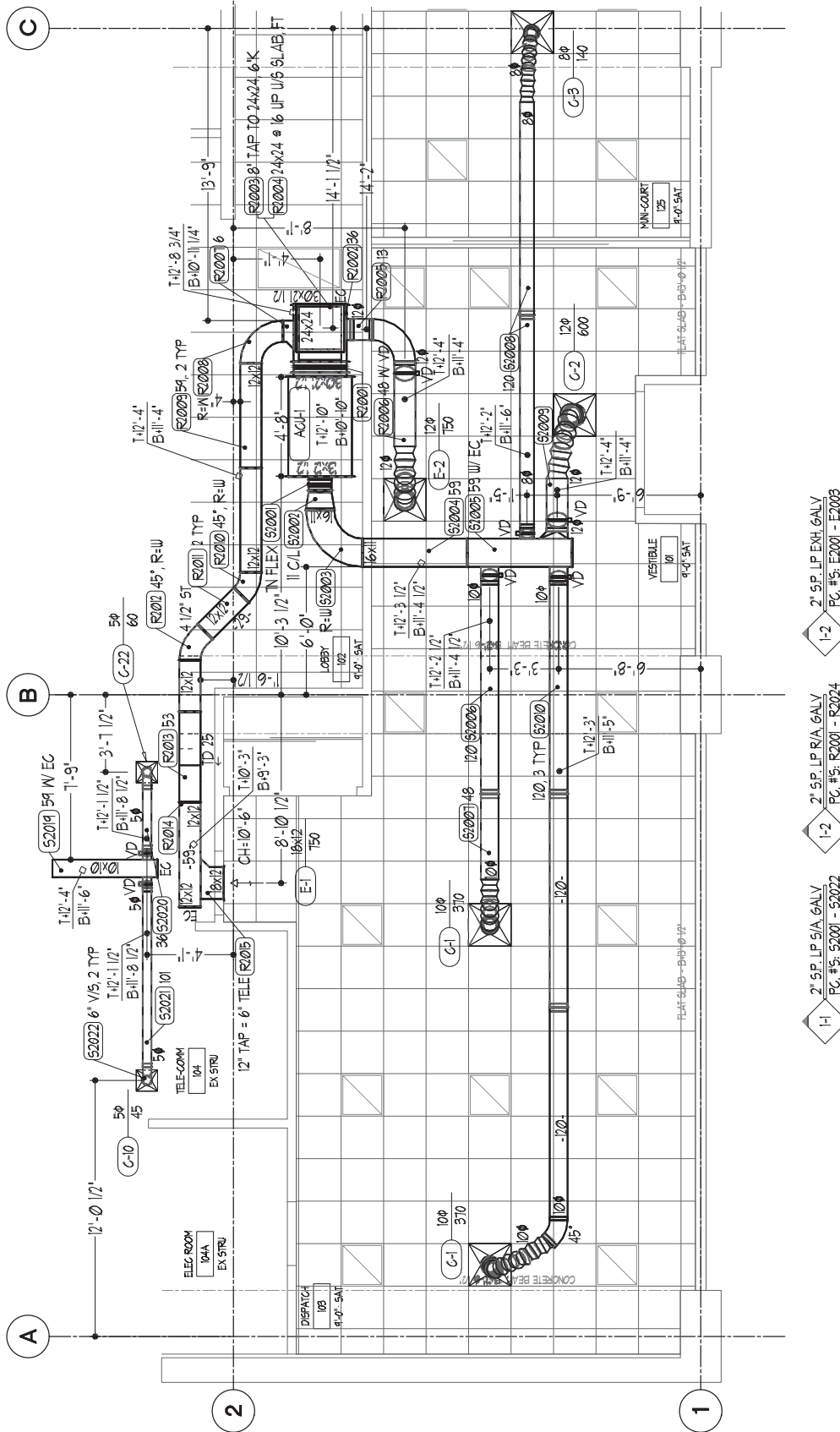


(b)

Courtesy Brad Dotson, B&D Consulting

Courtesy W. Alan Gold Consulting Mechanical Engineer and Robert Evenson Associates AIA Architects

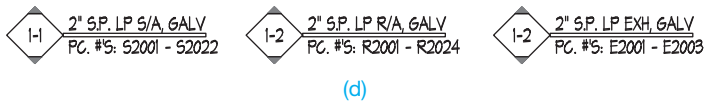
**FIGURE 23.15** (a) HVAC contract drawing for the engineer's sketch shown in Figure 23.14. (b) The 3-D HVAC contractor or shop drawing created by the HVAC contractor for the contract drawing shown in Figure 23.15a.



# PARTIAL H.V.A.C. SYSTEM LAYOUT

(c)

**FIGURE 23.15** (Continued) (c) The 2-D HVAC contractor or shop drawing created by the HVAC contractor for the contract drawing shown in Figure 23.15a.



**FIGURE 23.15** (Continued) (d) The tags at the bottom of the drawing in Figure 23.15c. Courtesy of Brad Dotson, B&D Consulting

## Creating an HVAC Contractor Drawing from an HVAC Contract Drawing

The HVAC contract drawing shown in Figure 23.15a is revised by the HVAC contractor when the HVAC system is ready to be built for delivery to the construction site. This revised drawing is called the **contractor drawing** or **shop drawing**. The HVAC contractor modified shop drawing of Figure 23.15a is shown in Figure 23.15b. The HVAC contractor edits the HVAC contract drawing to show the additional information needed for use by the fabrication shop to build and install the HVAC components. Figures 23.14, 23.15a, and 23.15b show the sequence of drawings from the engineer's single-line sketch to the HVAC contract drawing and to the finished shop drawing from the contractor. The drafter who creates the HVAC contractor shop drawings is often called a **detailer**. The HVAC shop drawing has these uses:

- Coordination with other trades.
- Fabricate the HVAC system.
- Install the HVAC system.

The following gives the basic steps used by the contractor to convert the HVAC contract drawing to a HVAC contractor shop drawing.

**STEP 1** The architectural and structural background plan is often modified to show ceiling heights and types. The structural objects are identified on the drawing, and elevations are given. Installation information is placed on the drawing, which includes locations, elevations, and any seismic restraints that are required.

**STEP 2a** If the coordination is being done in a 3-D model with **collision detection testing**, then the only requirement on the drawing is to have the system modeled. Collision detecting is a software application that automatically detects any interference that occurs between the HVAC system and other construction members in the building. This allows the HVAC contractor to modify the ductwork around the obstruction. Figure 23.15b shows the 3-D HVAC contractor or shop drawing created by the HVAC contractor for the contract drawing shown in Figure 23.15a.



### 3-D HVAC Models

For additional examples of impressive 3-D HVAC models, go to the Student CD, select Supplemental Material, select **Chapter 23**, and then **3-D HVAC Models**.

**STEP 2b** If shop drawing is being done in 2-D, then you must note the size of each duct, the information on each fitting, and the elevations of each part of the system. To use the drawing to fabricate materials, you have to place all of the information for each HVAC piece on the drawing. This includes size, static pressure, and length. HVAC fittings such as transitions and elbows have additional information specified. For example, a transition specifies the offset on the top or side and identifies the type of offset, such as a straight offset or an ogee offset. For elbows, the radius must be shown. Figure 23.15c shows the 2-D HVAC contractor or shop drawing created by the HVAC contractor for the contract drawing shown in Figure 23.15a.

**STEP 3** The detailer also looks for ways to streamline the HVAC system and save money. For example, an engineer might indicate a type of fitting on the contract document that is very expensive to make. The detailer replaces this fitting with a less-expensive one and gets approval for the change from the engineer. The detailer also looks for space constraint issues. For example, the engineer shows a 12" deep duct going under a beam. The beam is 16" from the finished ceiling. This situation appears to be acceptable on the original design. However, as the detailer takes a closer look, it is found that the ceiling is a sheetrock ceiling, and the span of the room is too long for 4" stud framing, so it has to be 6" framing. The duct is a medium pressure supply air and has to have 2" of insulation. The beam is a steel beam, so it has to be fireproofed with 1-1/2" of spray-on fireproofing. The ceiling ends up 6 5/8" thick, and the duct ends up 16" deep with the insulation. With the addition of 1-1/2" of fireproofing, close to 25" of materials must fit into 16" of space. The detailer modifies the drawings to accommodate the proper duct run.

**STEP 4** The detailer completes the HVAC contractor shop drawing shown in Figure 23.15c. The HVAC contractor drawing is fully detailed with locations, elevations, duct sizes, equipment **tags**, fitting information, air-device tags, and **piece numbers**. Tags are used on drawings to identify common symbols such as supply, return, and exhaust fittings in the case of an HVAC drawing. As you look at Figure 23.15c, notice the tags for the **list numbers** at the bottom of the drawing. The tags are split into three systems: supply (S), return (R), and exhaust (E). Notice that the **static pressure (SP) classifications** are also listed in the tag, as well as the range of the piece numbers. Static pressure classifications are standard construction specifications based on the internal static pressure present in the duct system. The construction of the ductwork varies widely based on this pressure classification. Generally, you will encounter low pressure (1/2" SP to 2" SP), medium pressure (3" SP to 4" SP), and high pressure (above 4" SP) duct systems. The higher the static pressure classification, the heavier the duct construction specification. As the pressure goes up,

gauges get heavier, different connectors are chosen, and internal or external reinforcement might be applied. In the upper static pressure classifications, negative pressure ductwork has a different, and heavier, construction specification than positive pressure ductwork. Static pressure in ductwork is measured in inches of water column in a pilot tube. To put the pressure in perspective, approximately 26" of static pressure equals 1 pound per square inch (psi). Piece numbers are a means of identifying each piece individually, so the fabricated piece can be installed in the correct location. Each piece is tagged on the drawing, on the cut sheet, and on a label affixed to the fabricated piece. Cut sheets are described later in this chapter. The piece numbers have a prefix indicating which type of system it is (S, R, or E). The numbers in this case are in the 2000 series. The 2000 series indicates that this duct is 2" static pressure classification. If the duct is constructed to a 4" static pressure classification, then the fittings are identified with a 4000 series number. So, by looking at the piece number, you can tell the system and static pressure. The tags at the bottom of the drawing in Figure 23.15c are shown in Figure 23.15d. You can interpret the first tag on the left, for example, as follows:

I-1 refers to level 1, material list 1.

2" SP LP S/A GALV indicates that this ductwork is to be constructed to the 2" static pressure construction classification, is low-pressure (LP) ductwork, is supply air (S/A) positive pressure, and it is to be constructed from galvanized (GALV) sheet metal.

PC #S: S2001-S2022 indicates the range of pieces on this drawing. Note that some of the pieces on the drawing do not have piece numbers on them. The pieces that do not have numbers on them are purchased fittings. The pieces that have numbers on them are fabricated fittings.



**NOTE:** This system is similar to the tagging methods used in the HVAC industry. Confirm the specific standard with the company where you work.

Static pressures are pressure classifications for construction of the ductwork based on the internal static pressure that the equipment in the system places in the ductwork. If the pressure classification is not indicated, it can be determined by identifying the external static pressure rating of the applicable fan-powered equipment. Be careful to use the external static pressure rather than the total static pressure for the equipment.

The terms *cutsheet* and *ductwork* can be spelled as one word or two words as in *cut sheet* and *duct work*.

## Creating a Cover Sheet and Cutsheet

A **cover sheet** provides information common to the entire list for a specific tag application in the contractor drawing. The cover

sheet can be used **in-house**, or it can be used in the event that the contractor needs to have a different shop fabricate the ductwork. The term *in-house* refers to fabricating the materials and fittings at the contractor's company. Many contractors detail and install the fittings but acquire the fabricated fittings from a sheet metal fabricator. The following is a typical example of a cover sheet and cutsheet, but the specific practice can vary between contractor. Confirm the preferred practice with your school or employer.

The cover sheet in Figure 23.16a has the following characteristics:

- The installing contractor and the project name or number or both are identified at the top.
- The next field identifies the **material list number**, which is sometimes referred to as a **pickoff number**.
- The area of the building is identified where the installation is located.
- Next are the following four lines of information:
  - **Rectangular Ductwork** indicates that all of the pieces in this material list are rectangular. The reason for separating rectangular and round is that the material lists can go to different areas of the shop, particularly in a large fabrication plant.
  - **Low-Pressure Standard Mechanical Construction** indicates that the system is not welded and is standard low-pressure construction.
  - **LP 2 S.P. Supply Air** indicates that the system is to be constructed to a 2" pressure classification and is positive pressure ductwork.
  - The next field has delivery information, job-site contact information, and **color-coding** information. Computer-generated labels are affixed to each piece and come in many different colors; these can be used to identify in which specific area of a building the materials are staged for installation.
- The last item is notes. Notes specify anything related to the material list or project. For example, note 1 refers the fabricator to the contractor's standard shop duct-construction standards. Because there is too much information to show in the individual cutsheets, most shops have a set of shop standards for each pressure class that the fabricator uses to determine the remainder of the required information. This includes, but is not limited to the grade of coatings on the sheet metal, longitudinal seam types, and internal and external reinforcing. Purchased fittings can also be listed in the notes. Purchased fittings are standard premanufactured fittings.

The **cutsheet** shows the dimensions and specifications for the fittings identified in the cover sheet. Figure 23.16b shows the cutsheet for the fittings identified in the Figure 23.16a cover sheet. The cutsheet in Figure 23.16b is for the radius elbow sheet on material list I-1. The title block at the top of the sheet provides the following information that matches the cover sheet:

- List number.
- Drawing number.
- Area.

<b>A.B.C. Sheetmetal Services</b>	
Anytown Civic Center	
<b>Pickoff #1-1</b>	
<b>Level 1, South</b>	
Rectangular Ductwork	
Low Pressure Standard Mechanical Construction	
Galvanized	
LP 2" S.P. Supply Air	
<b>Deliver to:</b>	
A.B.C. Sheetmetal Services	
Intersection of Tanner & Burke Road	
Anytown, Indiana	
<b>Attn:</b>	Steve Parker, General Foreman
<b>Phone:</b>	555-499-5077
<b>Fax:</b>	555-437-7432
<b>Color Coding for Labels:</b>	Orange
<b>Notes:</b>	
1 -	See A.B.C. Sheetmetal Shop Duct Construction Standards for gauges & reinforcement.
2 -	All tags to include area designation & pickoff number.

(a)

<b>Anytown Civic Center ~ Anytown, Indiana</b>												
<b>Radius Elbow</b>												
<b>List #:</b>	1-1	<b>Date:</b>	6/20/10	<b>Notes:</b>								
<b>Drawing #:</b>	1S	<b>Due Date:</b>										
<b>Area:</b>	South	<b>Const.</b>	2" S.P.									
<b>System:</b>	LP SA	<b>Material:</b>	GALV.									
<b>Mark</b>	<b>Qty.</b>	<b>A</b>	<b>B</b>	<b>C</b>	<b>D</b>	<b>E</b>	<b>F</b>	<b>Radius</b>	<b>Degree</b>	<b>Conn. 1</b>	<b>Conn. 2</b>	<b>Notes</b>
S2003	1	16	11	16	11	0	0	16	90	S-D	S-D	
S2013	1	14	12	14	12	0	0	14	90	S-D	S-D	

(b)

**FIGURE 23.16** A cover sheet and cutsheet for ducts used in tag 1-1 in the Figure 23.15c contractor drawing and the same tags shown in Figure 23.15d. (a) Cover sheet for the list 1-1. (b) The rectangular radius elbow cutsheet for list 1-1.

Courtesy of Brad Dotson, B&D Consulting

- System.
- Construction type.
- Material type.

The current date and the due date are also provided. The due date is the date that delivery to the job site is required.

The notes section provides any information related to the material list. For example, if all of the pieces on the list require **sound liner**, then that information can be indicated in the notes rather than on each piece. Sound liner is acoustical insulation applied to the interior of a duct.

Below the title block is a generic drawing of the fitting, with the following different fields noted.

- Mark: Piece number for the fitting; it correlates to the fitting number shown on the shop drawing.
- Qty: Quantity of pieces required.
- A: Width of the piece at end one.
- B: Depth of the piece at end one.
- C: Width of the piece at end two.
- D: Depth of the piece at end two.
- E: Amount of straight required at end one.
- F: Amount of straight required at end two.
- Radius: Throat radius of the fitting. The most common configuration for radius elbows is a throat radius equal to the width of the elbow. The throat radius is the inside radius of the elbow (see Figure 23.16b). Some engineers allow a throat radius equal to half of the elbow width, especially on lower static pressures.
- Degree: Degree of bend required.
- Conn. 1: Connector type at end one. Fitting S2003 has S-D noted. This is a slip and drive connector, which is very common on low-pressure duct systems.
- Conn. 2: Connector type at end two.
- Notes: Notes that apply only to that fitting. For example, you might indicate that a volume damper is to be installed in the straight part at end 2.

Cutsheet formats vary widely between contractors, depending on their company standards and their requirements. Confirm the preferred cutsheet format with your school or company.

### Additional Duct System Examples

Several examples of duct system elements are shown comparing the engineering sketch and formal drawing in Figure 23.17.

### Single- and Double-Line HVAC Plans

HVAC plans are drawn over the floor plan layers using HVAC layers. The floor plan layout is drawn first as a base sheet for the HVAC layout. The HVAC plan is then drawn using thick lines and notes for contrast with the floor plan. The HVAC plan shows the placement of equipment and ductwork. The duct size

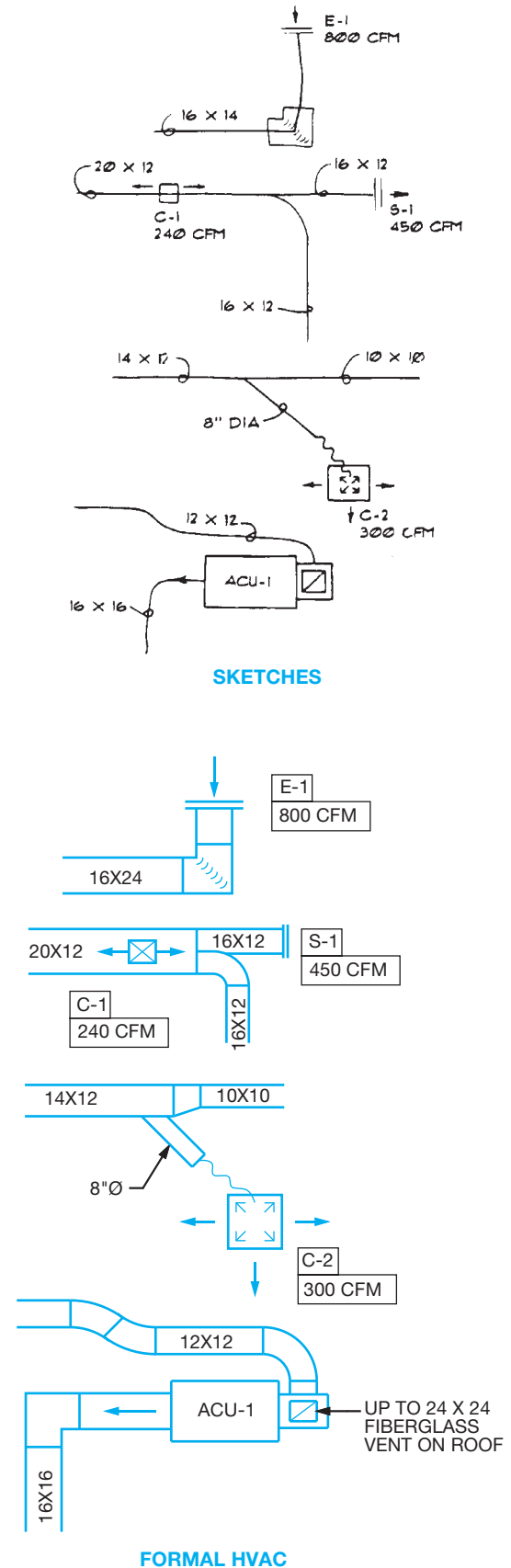
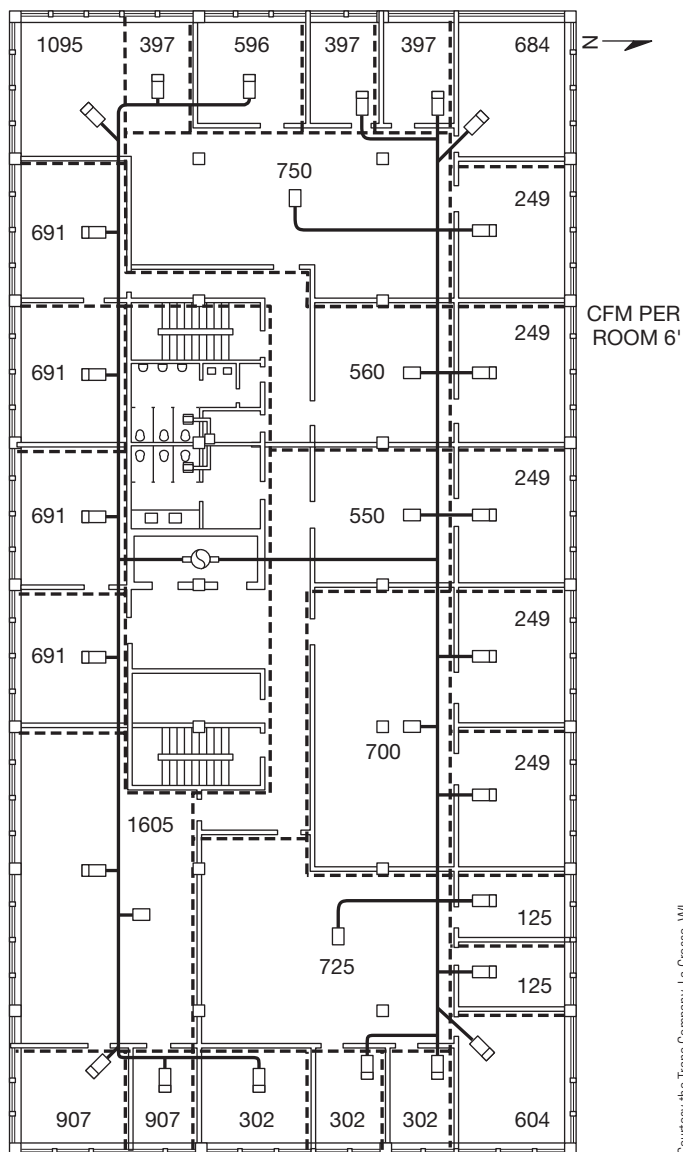


FIGURE 23.17 Examples showing engineering sketches converted to formal HVAC drawings.

(in inches) and shape (with symbols,  $\emptyset$  = round,  $\square$  = square or rectangular) of ductwork and system component labeling is placed on the drawing or keyed to schedules. Drawings can be either single-line or double-line, depending on the needs of the client or how much detail must be shown. Single-line drawings are easier and faster to draw. In many situations, single-line drawings are adequate to provide the equipment placement and duct routing as shown in Figure 23.18. However, caution should be exercised when using single-line drawings to ensure that there is adequate space for installation of the system. Double-line drawings take up more space and are more time-consuming to draw than single-line, but they are often necessary when complex systems require more detail as shown in Figure 23.15a. It is common to use specialized 3-D HVAC programs to draw and design systems to allow coordinating between multiple disciplines on large commercial projects (see Figure 23.15b).



Courtesy the Trane Company, La Crosse, WI

**FIGURE 23.18** Single-line ducted HVAC system showing a layout of the proposed truck and runout ductwork.

## HVAC Symbol Specifications

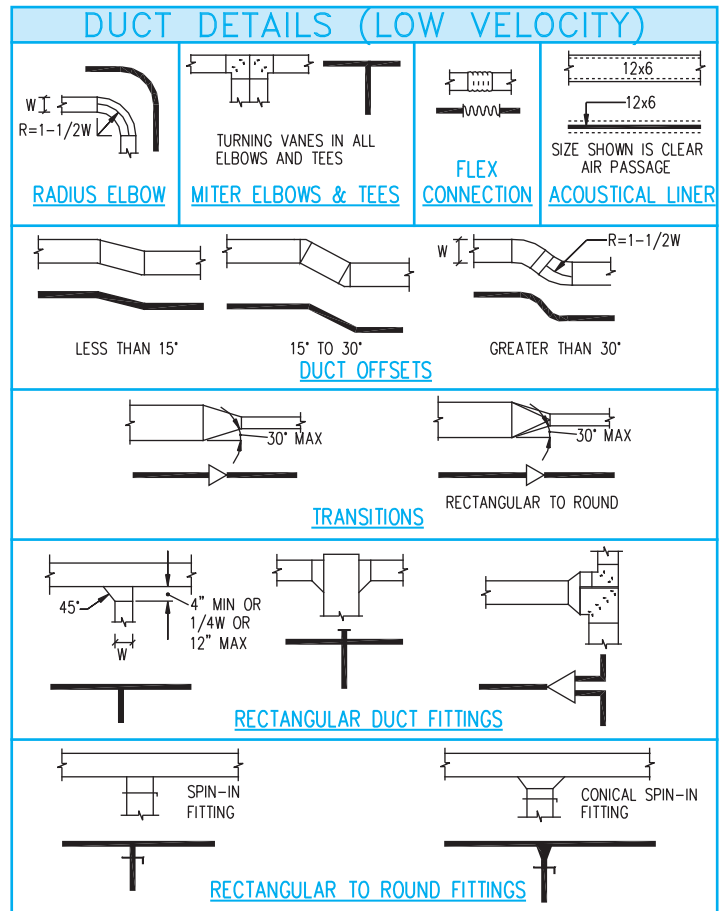
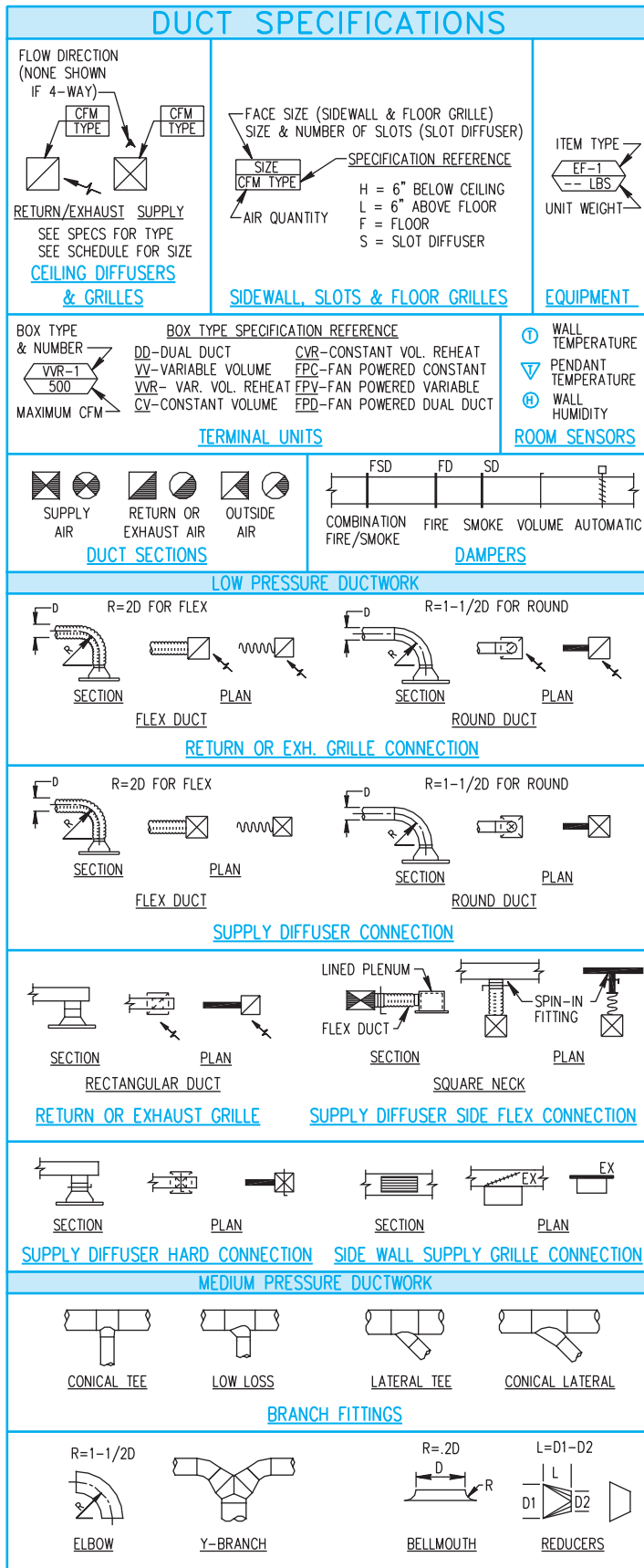
A large variety of HVAC symbols can be placed on a drawing. Symbols and notes are used to show and label floor, ceiling, and wall ducts; diffusers; and grills. Duct runs can be shown in plan view and in section. Ducts and components can be drawn in 3-D, double-line, or single-line representations. The size of double-line ducts is represented by the width of the duct in plan view. The outlines of the duct runs are drawn with thick lines so that the ducts and related connections and equipment contrast with the rest of the drawing. The sectional view displays both the width and height. Single-line drawings are commonly created with a very thick line representing the duct run and symbols to show the related connections and equipment. Common symbol specifications for double-line and single-line HVAC drawings are shown in Figure 23.19a. Many companies include an HVAC legend on a separate sheet of their drawings. This legend also provides information about the standards that are used by the company. Figure 23.19b shows an example of an HVAC legend. This legend is another good place to find information about how to create HVAC drawings.

## Written Specifications

HVAC drafting standards and specifications are important whether the drawings are created manually or with CADD. Many companies have a standards manual or instructions that correlate with the way the HVAC drawings are created. The numbered standards instructions in Figure 23.20a correlate to the numbers found on the sample drawing in Figure 23.20b. Follow these instructions as you create your own HVAC drawings. This is a common example of HVAC specifications. Keep in mind that other variations are found in industry.

## Residential Specifications

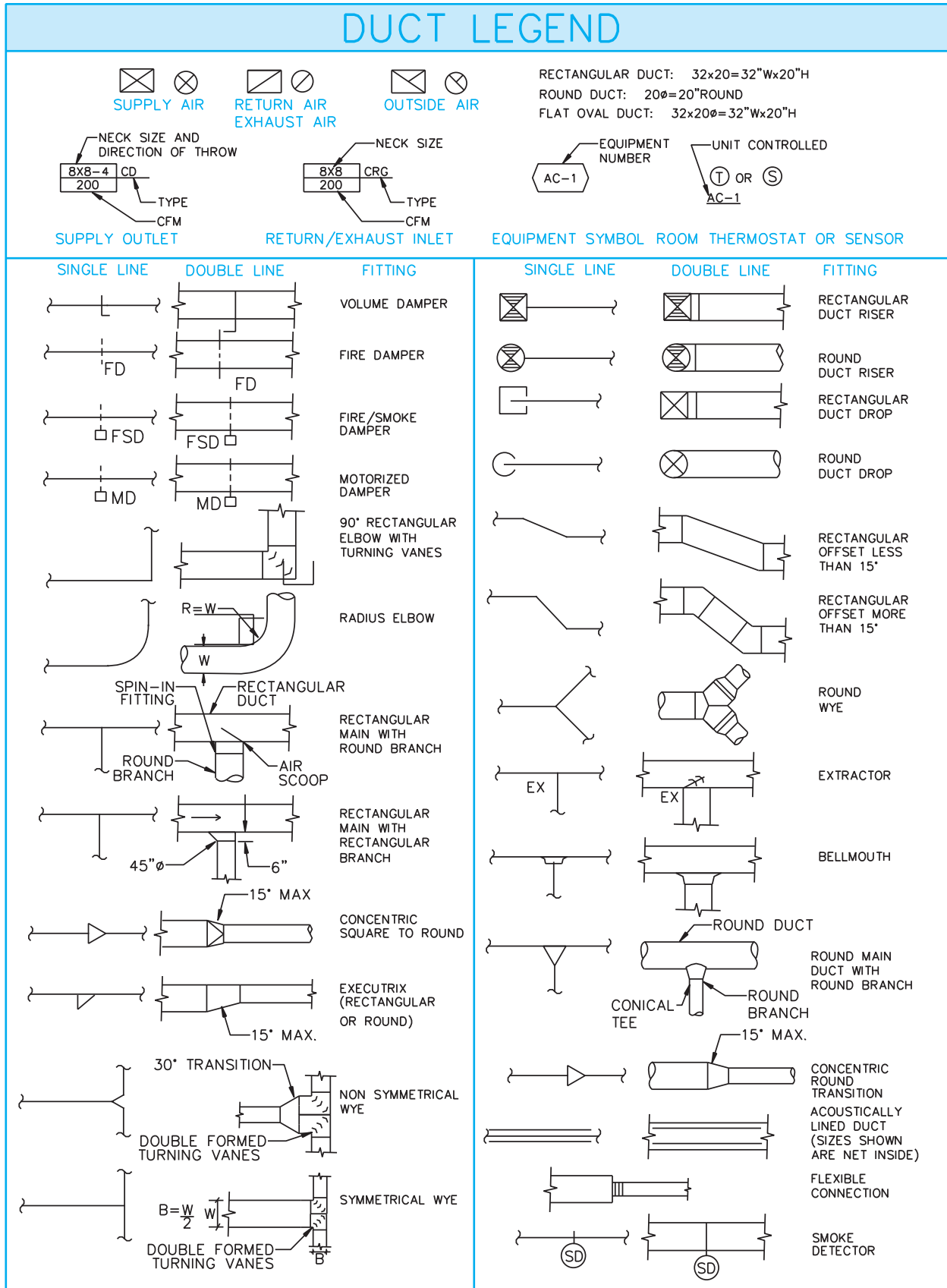
**Residential specifications** can take the same form as commercial specifications, but most lenders have a format for providing residential construction specifications. The Federal Housing Administration (FHA) or the Federal Home Loan Mortgage Corporation (FHLMC) has a specification format titled *Description of Materials*. This specifications form is used widely, as is or with revisions, by most residential construction lenders. The same form is used by the Farm Home Administration (FmHA) and by the Veterans Administration (VA). You can access the FHA *Description of Materials* form online by doing an Internet search using the phrase “FHA Description of Materials.” The plans, construction specifications, and building contract together become the legal documents for the construction project. These documents should be prepared very carefully in cooperation with the architect, client, and contractor. Any variation from these documents should be approved by all three parties. When brand names are used, a clause specifying an equivalent in value to the one specified can be substituted with the client or construction supervisor’s approval.



(a)



FIGURE 23.19 (a) Common HVAC symbol specifications. Courtesy PAE Consulting Engineers





**FIGURE 23.19** (Continued) (b) An HVAC legend is commonly found on a drawing to help communicate drafting standards. Courtesy Interface Engineering

## INSTRUCTIONS FOR NOTES:

- DO NOT PUT TEXT ON/UNDER DUCT LINES. MOVE TEXT IF NEW DUCT GOES OVER OLD TEXT.
- INSERT REVISION CLOUD DELTA IN CLOUD LINE.  
Example 
- IF POSSIBLE STRETCH OR EXTEND LINES INSTEAD OF ADDING SHORT SEGMENTS TO EXISTING LINES.
- BREAK PIPE LINES FOR ALL UNIONS, VALVES AND OTHER PLUMBING FITTINGS. Example 
- USE THICK LINES FOR WASTE AND EXTRA THICK LINES FOR SINGLE LINE DUCT WORK.
- HVAC VENT LAYER SHOULD BE USED FOR STEAM OR FUEL OIL VENTING ONLY, USE PLUMBING VENT IN ALL OTHER VENT CASES.
- DO NOT BREAK LEADER LINES FOR OTHER LEADERS UNLESS INSTRUCTED OTHERWISE BY ENGINEER. TRY TO MOVE THINGS UNTIL ROOM FOR CORRECT LEADER AND NOTES ARE FOUND.

8. TO LABEL TERMINAL UNITS:

USE LARGE EQUIPMENT BOX TO LABEL ALL TERMINAL UNITS.



9. TO LABEL EQUIPMENT:

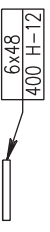
USE LARGE EQUIPMENT BOX TO LABEL ALL EQUIPMENT.



10. DIFFUSER BOXES:

USE THE SMALL DIFFUSER BOX FOR RETURN/EXHAUST AND SUPPLY CEILING DIFFUSERS AND GRILLES.



Example 

Example 



11. DO NOT PUT DIMENSIONS OR LABELS FOR DUCTS OR OTHER EQUIPMENT IN A DUCT THAT IS NOT THE ONE BEING LABELED.

12. READ AND USE THE MECHANICAL LEGENDS FOR EXAMPLES AND OTHER INFORMATION NOT SHOWN ON THIS SHEET.

13. WHEN LABELING A DUCT UP OR DOWN, WITH AN ARROW, THE FIRST NUMBER OF THE LABEL IS THE HORIZONTAL DIMENSION AND THE SECOND IS THE VERTICAL DIMENSION REGARDLESS OF WHICH SIDE THE ARROW POINTS.



## DRAWING INSTRUCTIONS

1. TERMINAL UNITS (\*R's & \*S) GO ON DUCT LAYER.  
2. IF LABEL IS \*R (VARIABLE VOLUME REHEAT) THEN USE TERMINAL UNIT W/REHEAT COIL.

3. LEADERS ON MULTI-LINE TEXT COME FROM THE UPPER LEFT OR THE LOWER RIGHT OF THE TEXT BLOCK

4. LEFT JUSTIFY ALL MULTI-LINE NOTES.

5. BREAKS FOR HIDDEN LINES ON DUCT & DIFFUSERS OR BREAKS IN PIPE LINES THAT CROSS NEED GAPS IN THE LINES. USE 'SB' BREAK COMMAND FOR BREAKING LINES IN DIFFUSERS AND SPECIAL CASES ONLY.

'B' BREAK COMMAND FOR BREAKING LINES OVER PIPING AND DOUBLE LINE DUCT LINES.

'BB' BREAK COMMAND FOR BREAKING A LINE OVER SINGLE LINE DUCT AND WASTE PIPE LINES.

6. TYPICAL OF #'s ARE WRITTEN (TYP. #), NOI (TYP #) OR (TYP. OF #).

7. THERMOSTATS - USE CIRCLE T, THERMOT & ARC - 3 FROM DOUBLE DUCT MENU TO KEEP ON CORRECT LAYERS.

8. USE STRAIGHT SPIN IN FITTINGS FOR ROUND DUCT OFF OF SQUARE DUCT (LOW PRESSURE DUCT ONLY).

9. USE CONICAL FITTINGS FOR ROUND TAKE-OFFS FROM ROUND DUCT (MEDIUM PRESSURE ONLY).

10. USE TICKS AND NOT ARROWS FOR ANY DIMENSIONING ON DRAWINGS.

11. ALL LETTERED ('SYMBOLS') HEX NOTES ARE TO BE PRIOR (LEFT SIDE) TO WRITTEN NOTES DISREGARDING WHICH SIDE LEADER COMES OFF. ALL 'NUMBER' HEX NOTES ARE TO BE AFTER (RIGHT SIDE) WRITTEN NOTES DISREGARDING WHICH SIDE LEADER COMES OFF.

12. ALL SUPPLY AND RETURN BRANCHES WILL HAVE DAMPERS. UNLESS OTHERWISE NOTED BY ENGINEER.

13. USE LOOP LEADERS TO LABEL SINGLE LINE PIPE AND ARROWS TO LABEL DROPS, RISERS AND VALVES ETC.

14. USE THE ARC ARROW ( <-C- ) TO LABEL RELOCATE EXISTING AND PUT HEX WITH R IN LINE. MOVE DIFFUSER LABEL TO LABEL NEW LOCATION AND PUT HEX R WITH LABEL. DIFFUSER IN NEW LOCATION IS ON NEW, NOT EXISTING LAYER.

15. DEMO LAYER FOR HVAC & DOUBLE LINE PIPE USES AN L3 LINE (MAGENTA) AND HIDDEN LINE TYPE. EACH ENTITY TYPE SHOULD HAVE ITS OWN DEMO LAYER ( DUCT, DIFFUSERS, DOUBLE LINE PIPES ETC.).

16. TO DEMO SINGLE LINE PIPE USE "DEMO X's" ROUTINE FROM THE LISP DROP-DOWN MENU. EACH ROUTINE CREATES A LAYER AND USES CORRECT COLOR FOR X's. (HVAC PIPING TYPES SUCH AS CHWS, HTWS, CDS ETC. CAN BE FOUND IN HVAC PIPING LEGEND.)

17. BREAK DUCT (OR PIPE) BETWEEN CAP AND DUCT (OR PIPE).

18. PIPES TO \*R's DO NOT HAVE DROPS UNLESS REQUESTED BY ENGINEER.

19. USE SQUARE DUCT BREAK FROM HVAC DROP-DOWN MENU AND PUT BREAK ON DUCT LAYER OF TYPE BEING BROKEN.

20. INTERNAL SOUND INSULATION IS ON THE DUCT LAYER OFFSET 3" USING THE HIDDEN LINE TYPE AND COLOR 3 (GREEN).

**FIGURE 23.20** (a) Numbered standards instructions used for creating standard HVAC symbols and drafting applications correlate to the circled numbers on (b) the sample drawing.

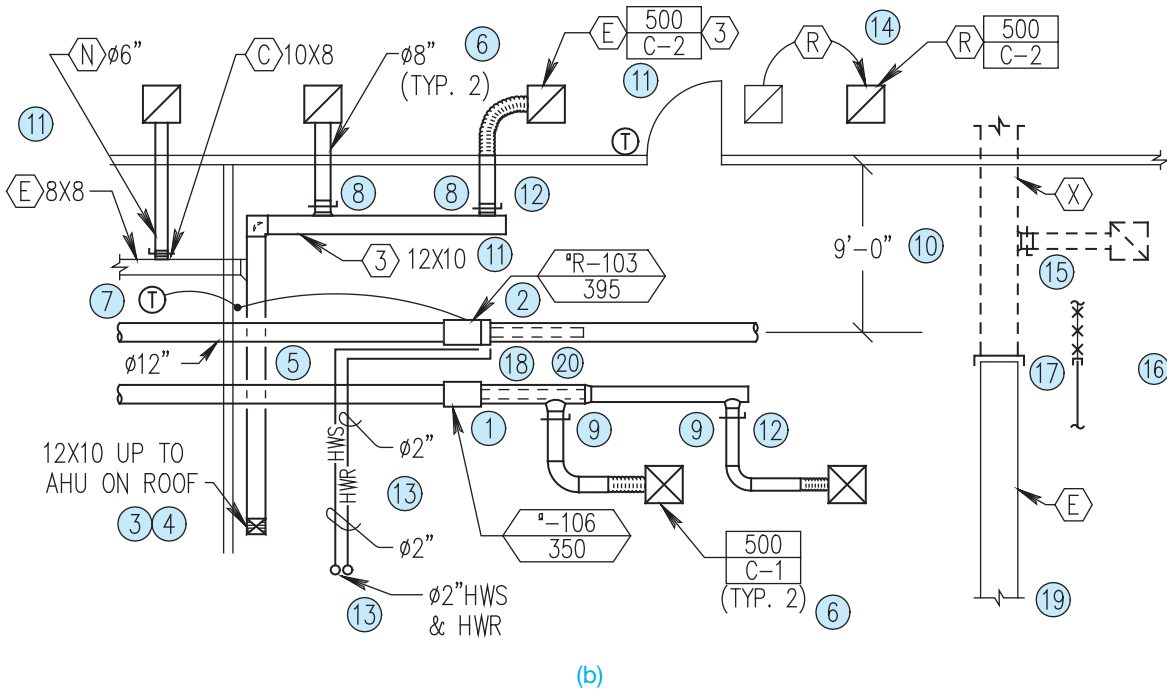


FIGURE 23.20 (Continued)

Courtesy PAE Consulting Engineers

Minimum construction specifications, as established by local building officials, vary from one location to the next, and their contents are dependent on specific local requirements, climate, codes used, and the extent of coverage. You should verify the requirements for a construction project in your location.

### Commercial Construction Specifications

Specifications for commercial construction projects are often more complex and comprehensive than the documents for residential construction. Commercial project specifications can provide very detailed instructions for each phase of construction. Specifications can establish time schedules for the completion of the project. Also, in certain situations, the specifications include inspections in conjunction with or in addition to those required by a local jurisdiction. Construction specifications often follow the guidelines of the individual architect or engineering firm, although a common format has been established titled *MasterFormat™: Master List of Numbers and Titles for the Construction Industry*, published by the Construction Specifications Institute (CSI) and the Construction Specifications Canada (CSC). The information used in this text are from *MasterFormat* and *UniFormat™* and are published by the CSI and CSC and used with permission from CSI, 2008.

The Construction Specifications Institute (CSI)  
 99 Canal Center Plaza, Suite 300  
 Alexandria, VA 22414  
 800-689-2900; 703-684-0300  
 www.csinet.org

*MasterFormat*, 2004 edition, is a master list of numbers and subject titles for organizing information about construction work results, requirements, products, and activities into a standard sequence. Construction projects use many different delivery methods, products, and installation methods. Successful completion of projects requires effective communication among the people involved. Information retrieval is nearly impossible without a standard filing system familiar to each user. *MasterFormat* Numbers and Titles facilitate standard filing and retrieval schemes throughout the construction industry. *MasterFormat* Numbers and Titles are suitable for use in project manuals, for organizing cost data, for reference keynotes on drawings, for filing product information and other technical data, for identifying drawing objects, and for presenting construction market data. Each *MasterFormat* number and title defines a section, arranged in levels depending on their depth of coverage. The broadest collections of related construction products and activities are level one titles, otherwise known as *divisions*. Each division in the *MasterFormat 2004 Edition: Numbers and Titles* is made up of level two, level three, and occasionally level four numbers and titles assigned by *MasterFormat*, each of which define a

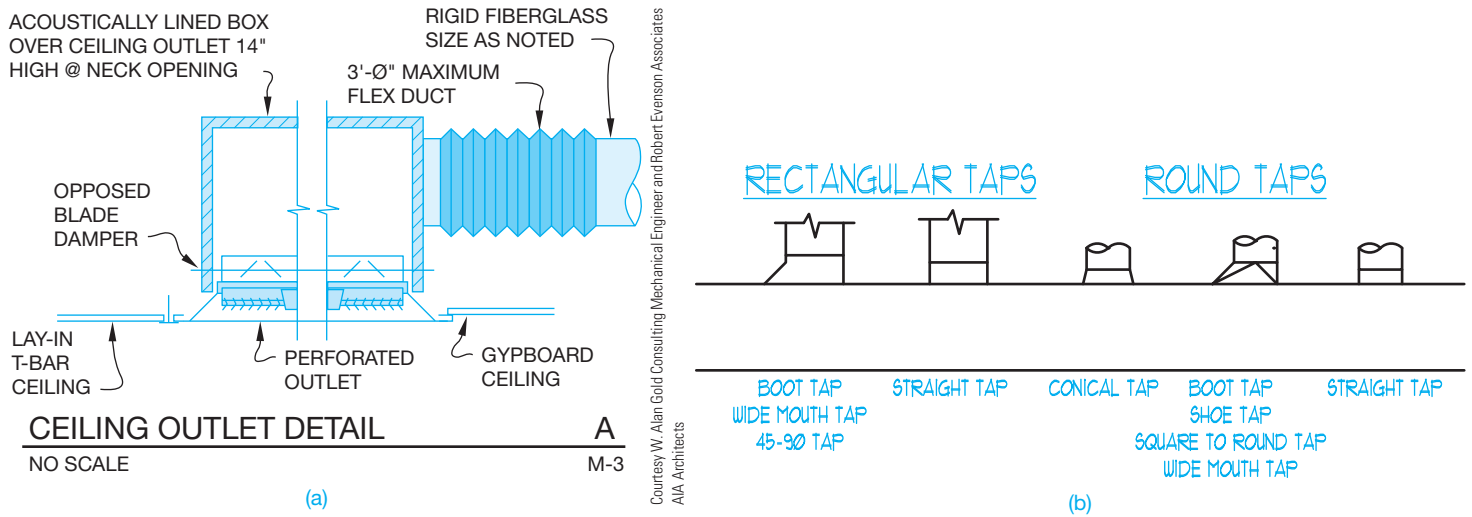


FIGURE 23.21 (a) Sample detail drawing. (b) A variety of common taps for rectangular and round duct applications. Courtesy of Brad Dotson, BE-D Consulting

gradually more detailed area of work results to be specified. Work results are traditional construction practices that typically result from an application of skills to construction products or resources.

### Detail Drawings

**Detail drawings** are used to clarify specific features of the HVAC plan. Single- and double-line drawings are intended to establish the general arrangement of the system; they do not always provide enough information to fabricate specific components. When further clarification of features is required, detail drawings are made. A detail drawing is an enlarged view(s) or larger-scale drawing of equipment, equipment installations, duct components, or any feature that is not defined on the plan. Detail drawings can be scaled or unscaled and provide enough views and dimensions for sheet metal shops to prepare fabrication patterns as shown in Figure 23.21. A larger-scale drawing overrules a smaller-scale drawing. So typically the detail drawing overrules the floor plan drawing, and written specifications generally overrule all drawings. *Overrules* means if the smaller-scale plan shows one thing, and the enlarged plan, detail, or section view shows something different, then you are required to provide what is shown on the larger-scale drawing. An example of this is when the floor plan layout shows a duct system with **straight taps** to the air devices. Whereas the enlarged detail shows a typical air device installation with **conical or wide-mouth taps**. In this case, the contractor is required to provide and install the conical or wide-mouth taps even though the floor plan clearly shows straight taps. This is a general rule of thumb, and it is how the situation is addressed in a legal conflict. The term *tap* refers to a fitting that connects or taps into a duct run. A straight tap is a tap that intersects the main duct the same size as the tapping

duct. A conical tap is a round tap that intersects the main duct at a larger size (usually by 1", and equally around the diameter) than the tapping duct. A wide-mouth tap is a tap that intersects the main duct at a larger size than the tapping duct in width only and is enlarged on the upstream side. Normally, the slope of the tap is 45°. Figure 23.21b shows a variety of common taps for rectangular and round duct applications.

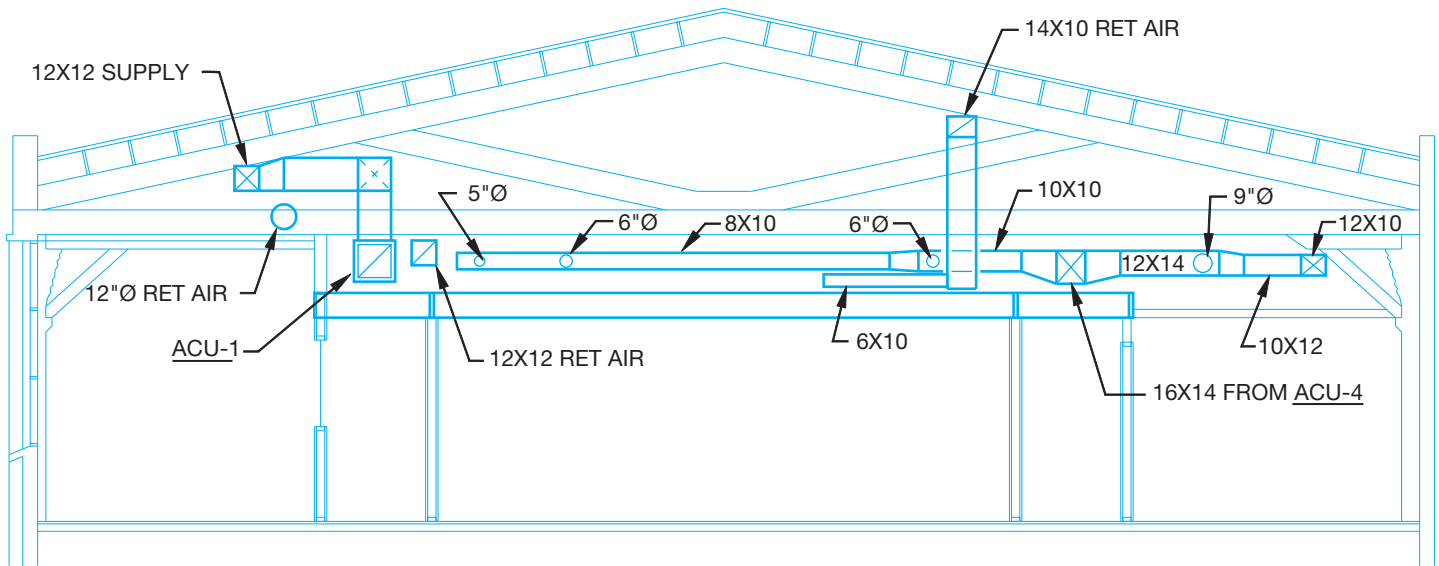
### Section Drawings

**Sections** or **sectional views** are used to show and describe the interior portions of an object or structure that are otherwise difficult to visualize. Section drawings are used to provide a clear representation of construction details or a profile of the HVAC plan as taken through one or more locations in the building. There are two basic types of section drawings used in HVAC. One method shows the construction of the HVAC system in relationship to the structural and architectural components of the building. In this case, the building is sectioned and the duct system is also sectioned.

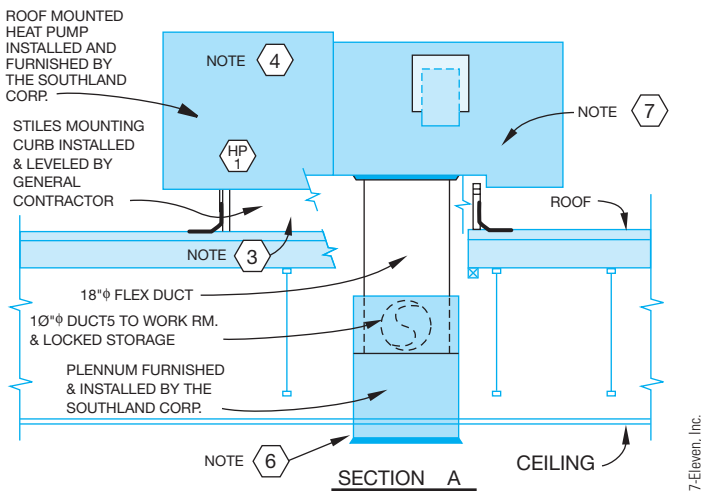
This drawing provides a profile of the HVAC system. There can be one or more sections taken through the structure, depending on the complexity of the project. The building structure can be drawn using thin lines as shown in Figure 23.22. Figure 23.22 is a section through the HVAC plan shown in Figure 23.15a. The other sectioning method is used to show detail of equipment or to show how parts of an assembly fit together (see Figure 23.23).

### Schedules

**Numbered symbols** are used on the HVAC plan to key specific items to charts known as **schedules**. These schedules are



**FIGURE 23.22** Section drawing through the HVAC system shown in Figure 23.15a. Courtesy W. Alan Gold Consulting Mechanical Engineer and Robert Evenson Associates AIA Architects



**FIGURE 23.23** Detailed section showing HVAC equipment installation.

used to describe items such as ceiling outlets, supply and exhaust grills, hardware, and equipment. Schedules are charts of materials or products that include size, description, quantity used, capacity, location, vendor's specification, and any other information needed to construct or finish the system. Schedules aid the drawing by keeping it clear of unnecessary notes. Schedules are generally placed in any convenient area of the drawing field or on a separate sheet. Items on the plan can be keyed to schedules by using a letter and number combination such as C-1 for CEILING OUTLET NO. 1, E-1 for EXHAUST GRILL NO. 1, or ACU-1 for EQUIPMENT UNIT NO. 1. The exhaust grill schedule keyed to the HVAC plan in Figure 23.15a can be set up as a chart as shown in Figure 23.24.

## Pictorial Drawings

**Pictorial drawings** can be isometric or oblique as shown in Figure 23.25. Isometric, oblique, and perspective techniques are discussed in Chapter 14, *Pictorial Drawings and Technical Illustrations*. Pictorial drawings are usually not drawn to scale. They are used in HVAC for a number of applications, such as assisting in visualization of the duct system, and when the plan and sectional views are not adequate to show difficult duct routing. Three-dimensional CADD models are commonly used today. Three-dimensional CADD models are valuable as shown earlier and as you will see in the CADD application featured on page 1044.

## DRAWING REVISIONS

**Drawing revisions** are common on HVAC projects. Revisions can be caused for a number of reasons. For example, changes requested by the owner, job-site corrections, correcting errors, or code changes. Changes are done in a formal manner by submitting an **engineering change order (ECO)** or **change order (CO)** to the contract, which is a written notification of the change that is accompanied by a drawing representing the change.

## Revision Clouds

A revision cloud is placed around the area that is changed. The **revision cloud** is a cloudlike circle around the change as shown in Figure 23.26. CADD programs commonly used for architectural and structural drafting have commands that allow you to easily draw the revision cloud. There is also a triangle with a revision number inside that is placed next to the revision cloud or along the revision cloud line as shown in

EXHAUST GRILL SCHEDULE									
SYMBOL	SIZE	CFM	LOCATION	DAMPER TYPE				TYPE	REMARKS
				FIRE DPR.	KEY OP. OPPBLD	KEY OP. EXTR	NO DPR.		
E-1	24x12	750	HIGH WALL	X	X			4	
E-2	18x18	720	CEILING	X	X			2	
E-3	10x10	240	CEILING		X			1	24x24 PANEL
E-4	10x10	350	CEILING		X			1	
E-5	12x12	280	CEILING		X			1	
E-6	10x10	500	CEILING	X	X			1	
E-7	6x6	350			X			2	
E-8	12x6	50			X			3	
E-9	12x6	200			X			3	
E-10	12x8	150			X			3	
E-11	10x10	290			X			3	
E-12	9x4	160			X			1	24x24 PANEL
E-13	9x4	75	HIGH WALL	X	X			4	

TYPE 1: KRUGER 1190 SERIES STEEL PERFORATED FRAME 23 FOR LAY-IN TILE

TYPE 3: KRUGER EGC-5: 1/2"x1/2"x1/2" ALUMINUM GRID

TYPE 2: KRUGER 1190 SERIES STEEL PERFORATED FRAME 22 FOR SURFACE MOUNT

TYPE 4: KRUGER S80H: 35° HORIZ. BLADES 3/4" OC

FIGURE 23.24 Exhaust grill schedule. © Cengage Learning 2012

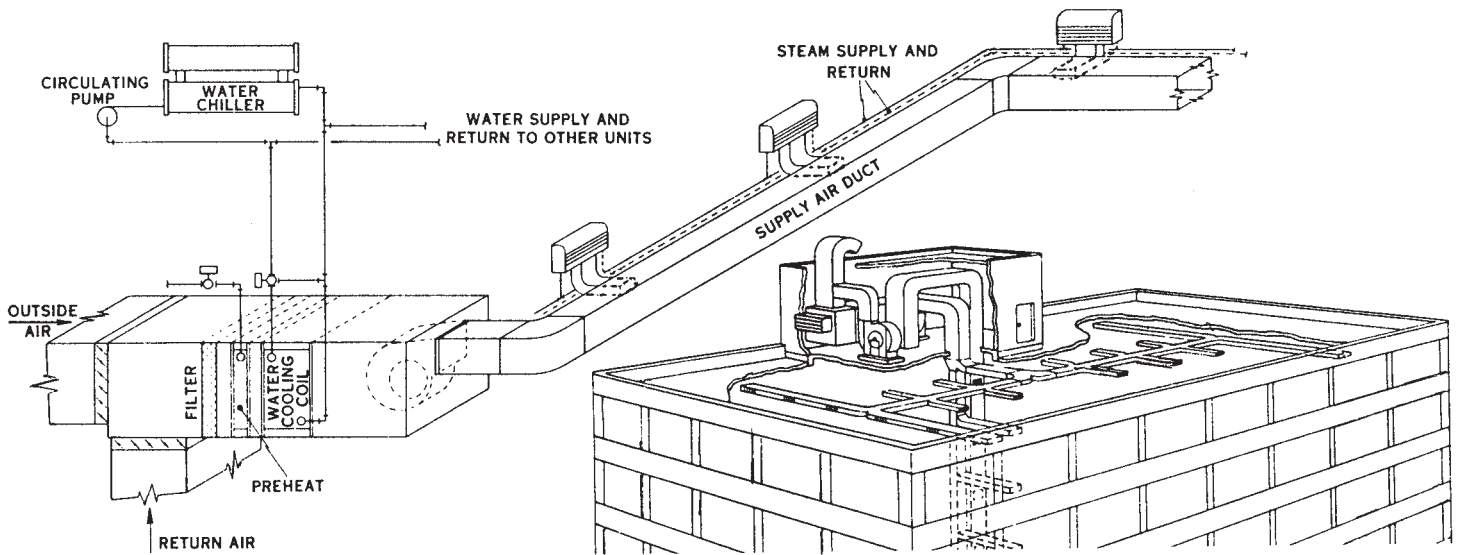


FIGURE 23.25 Pictorial drawings. Courtesy The Trane Co, LaCrosse WI

Figure 23.27. The triangle is commonly called a **delta** or **flag note**. The number is then correlated to a revision note placed somewhere on the drawing or in the title block as shown in Figure 23.28. Each company has a desired location for revision notes, although common places are in the corners of the drawing, in a revision block or table or in the title block. This practice is not as clearly defined on architectural drawings as in ASME standard drawings as covered in Chapter 2 of this textbook. The note is used to explain the change. If a reference is given in the title block, then detailed information about the

revision is normally provided in the revision document that is filed with the project information. The revision document is typically filled out and filed for reference. Changes can cause increased costs in the project.

### DUCT SIZING

The following HVAC duct sizing content is provided by Brandon Zeleniak, Sheet Metal Worker–General Foreman, and HVAC Design Coordinator, Desert Plumbing & Heating, Las Vegas, NV.

When preparing sheet metal shop drawings, it is often necessary to alter the size or shape of the duct in order to route the duct where it is needed. Although ductwork is usually the largest mechanical utility in a building, it is also the most versatile. Other utilities such as plumbing, piping, or conduit cannot alter their shape to accommodate the interference found in the building.

### The Effect of Volume (CFM) on Duct Sizing

The first factor to consider in duct sizing is the amount of air required, which is calculated in cubic feet per minute (CFM). The required CFM indicates the amount of air supplied from

the supplying unit or the main duct to the final destination. The volume of air required in a given area depends on the heat load being controlled.

### The Effect of Velocity (FPM) on Duct Sizing

The next characteristic you need to determine is the velocity of air traveling inside the duct. Air velocity is calculated in feet per minute (FPM). The exact same volume of air (CFM) when traveling through different sized ducts creates much different results. In different applications, the velocity varies, depending on sound requirements or the distance of travel between the air diffuser and the heat load. For example, in a gymnasium

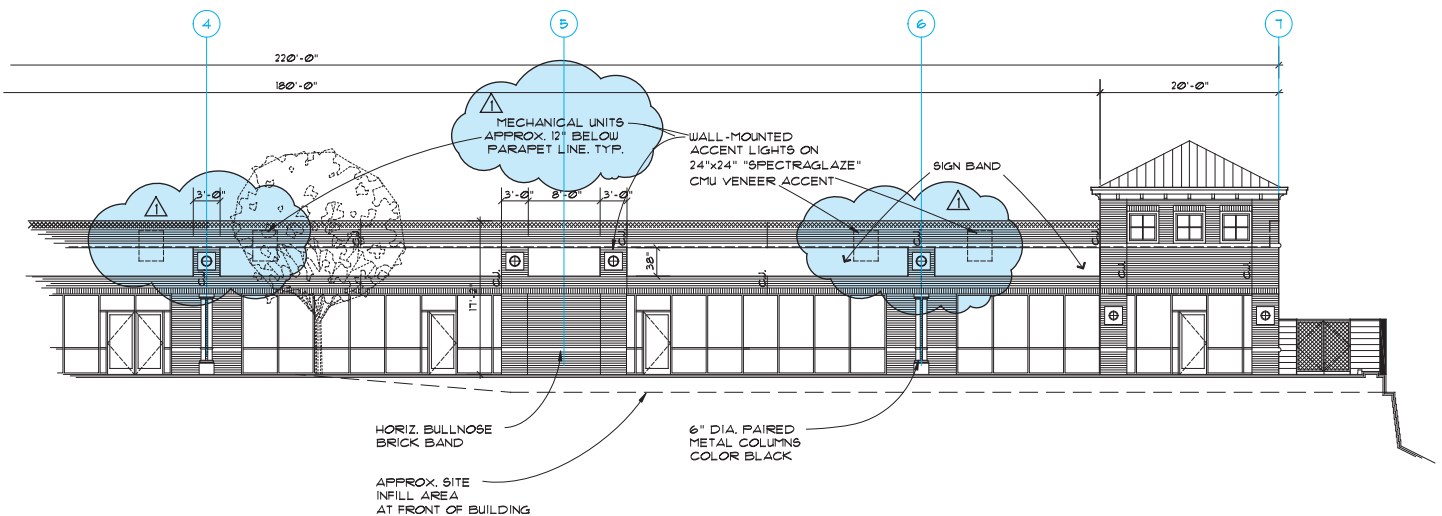


FIGURE 23.26 A typical revision cloud and delta reference. Portion of drawing courtesy Ankrom Moisan Architects

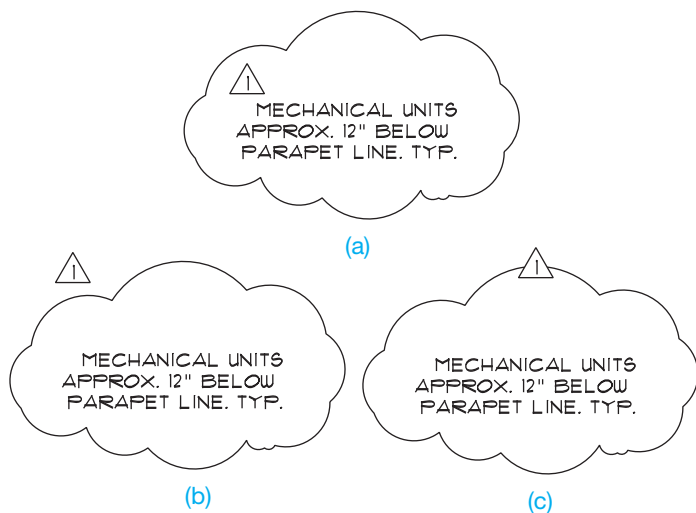


FIGURE 23.27 Placement of the delta reference with the revision cloud. (a) Delta inside of the revision cloud. (b) Delta outside of the revision cloud. (c) Delta inserted in the revision cloud line. © Cengage Learning 2012

CedarOak	EXTERIOR
REVISIONS	
REVISION 1	
DATE	03/07/01
FILE	A3-1
JOB	960000
DWN,KC	CHK,ME
A3.1	
OF SHEETS	

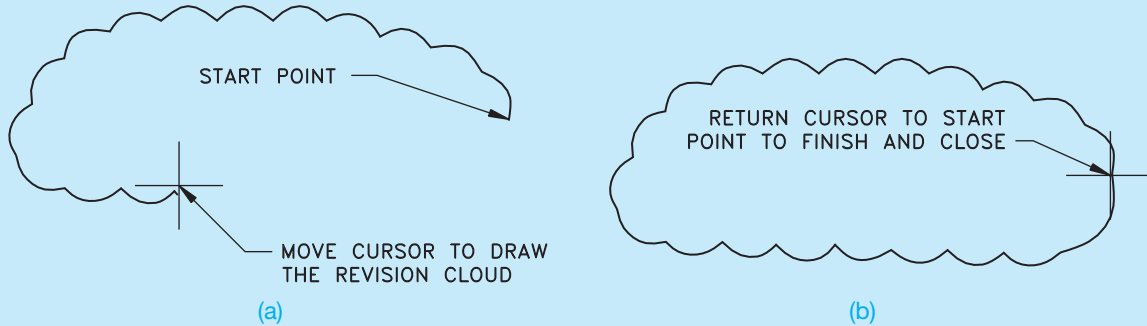
SCALE: 1" = 8'-0"

Portions of title block courtesy Ankrom Moisan Architects

FIGURE 23.28 Revision reference in the title block. The specific information about the revision is found in the job file.

It is easy to draw revision clouds with CADD. AutoCAD®, for example, has a REVLOUD command that allows you to specify the revision cloud's arc length and style and to draw a revision cloud around any desired area. The command works by picking a start point and then moving the cursor in the desired direction to

create the revision cloud, as shown in Figure 23.29a. Create the revision cloud in a pattern around the desired area while moving the cursor back toward the start point. When the cursor is returned to a point close to the start point, the cloud is automatically closed as in Figure 23.29b.



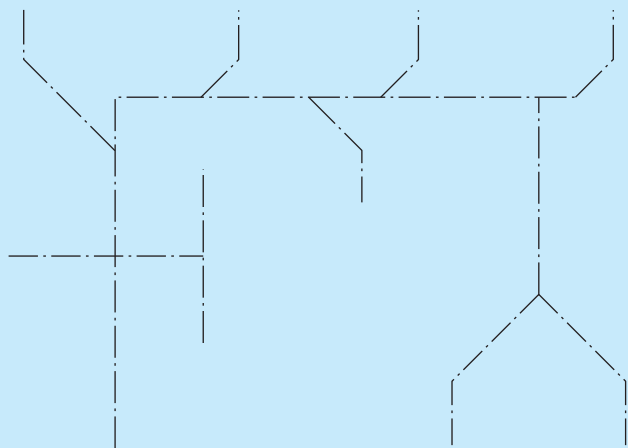
**FIGURE 23.29** The AutoCAD REVLOUD command automatically draws arc segments along the cursor's path. (a) Start and continue the revision cloud construction. (b) Complete the revision cloud.

© Cengage Learning 2012

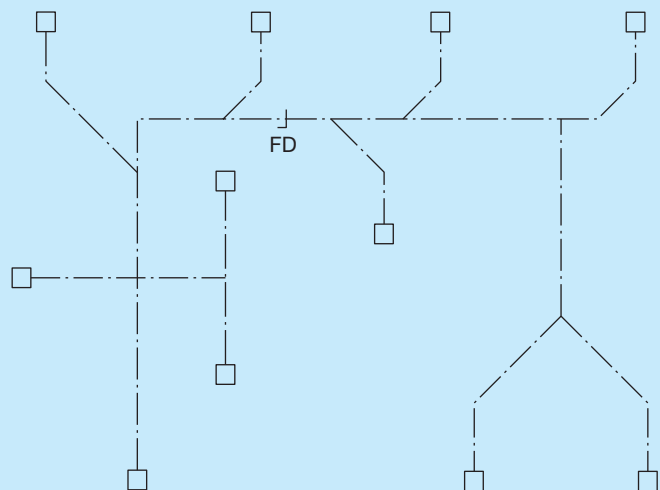
### HVAC PLANS

HVAC CADD software is available that allows you to place duct fittings and then automatically size ducts in accordance with common mechanical equipment suppliers' specifications. The CADD drafter typically uses the floor plan as a reference layer and develops the HVAC plan as a separate layer using the following steps:

- STEP 1** The drawing begins with the preliminary layout drawn as the duct centerlines (see Figure 23.30).
- STEP 2** Select supply and return registers from the template menu symbols library and add the symbols to the end of the centerlines where appropriate (see Figure 23.31).



**FIGURE 23.30** Step 1: The drawing begins with the preliminary layout drawn as duct centerlines. © Cengage Learning 2012



**FIGURE 23.31** Step 2: Select supply and return registers from a symbols library menu. © Cengage Learning 2012

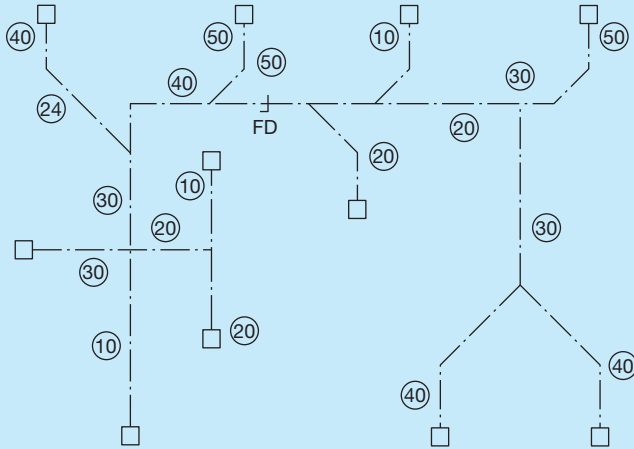
(Continued)



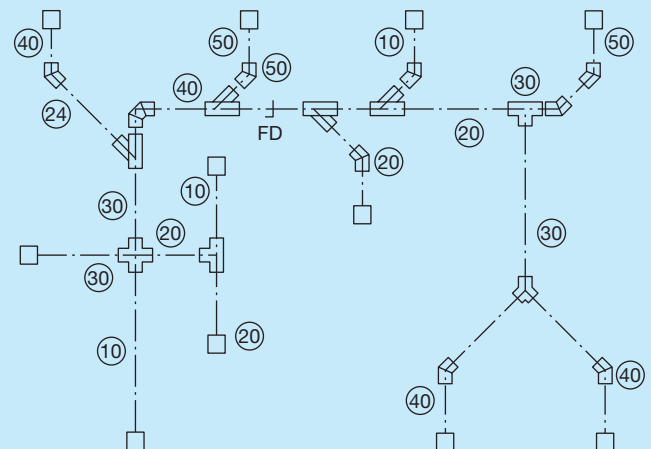
- STEP 3** The program then automatically identifies and records the lengths of individual duct runs and then tags each run. Fittings are located and identified by the type of intersection (see Figure 23.32). As all of this drawing information is added to the layout, the computer automatically gathers design information into a file for duct sizing based on a specific mechanical manufacturer's specifications selected by the user.
- STEP 4** After the fitting location and sizes are determined, the program transforms each fitting into accurate double-line symbols according to the ANSI Y32.2.4 standard (see Figure 23.33).
- STEP 5** When the fittings are in place, the program calculates and draws the connecting ducts, adding couplings automatically at the maximum duct

lengths. If a transition is needed in a duct run, the program recommends the location and all you have to do is pick a transition fitting from the menu library. See Figure 23.34 for the complete HVAC layout.

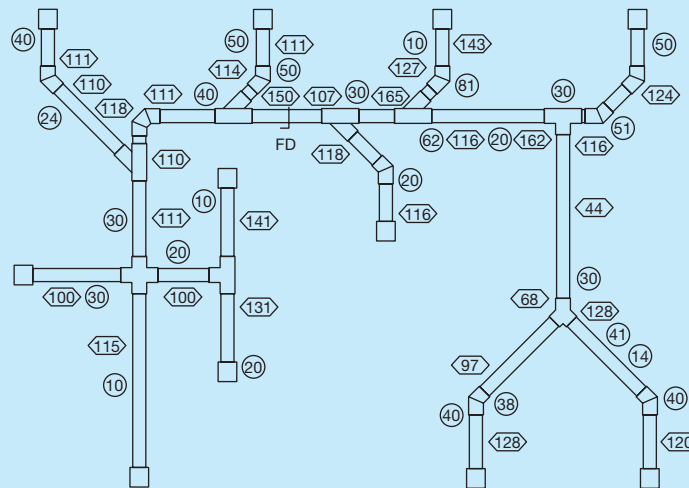
An added advantage of using HVAC CADD software is that the program automatically records information while you draw to generate a complete bill of materials. The systems that offer you the greatest flexibility and productivity are designed as a parametric package. This type of program allows you to set the design parameters that you want and then the computer automatically draws and details according to these settings. As you draw, information such as the type of fitting, cubic feet per minute (CFM), and gauge is placed with each fitting. A partial HVAC plan is shown in Figure 23.35.



**FIGURE 23.32** Step 3: Fittings are located and identified by the type of intersection. © Cengage Learning 2012



**FIGURE 23.33** Step 4: HVAC symbols are drawn as accurate double-line symbols exactly to ANSI Y32.2.4 standards. © Cengage Learning 2012



**FIGURE 23.34** Step 5: The finished HVAC plan.

© Cengage Learning 2012

(Continued)

### CADD LAYERS FOR HVAC DRAWINGS

The American Institute of Architects (AIA) CADD Layer Guidelines establish the heading “Mechanical” as the major group identification for HVAC-related CADD layers. The AIA CADD Layer Guidelines were also adopted by the U.S. National CAD Standard. The following are some of the recommended CADD layer names for HVAC applications:

Layer Name	Description
M-CHIM	Prefabricated chimneys
M-CMPA	Compressed-air systems
M-CONT	Controls and instrumentation
M-DUST	Dust and fume collection systems
M-ENER	Energy management systems
M-EXHS	Exhaust systems
M-FUEL	Fuel system piping
M-HVAC	HVAC system
M-HOTW	Hot-water heating system
M-CWTR	Chilled-water system
M-REFG	Refrigeration system
M-STEM	Steam system
M-ELEV	Elevations
M-SECT	Sections
M-DETL	Details
M-SCHD	Schedules and title block sheets

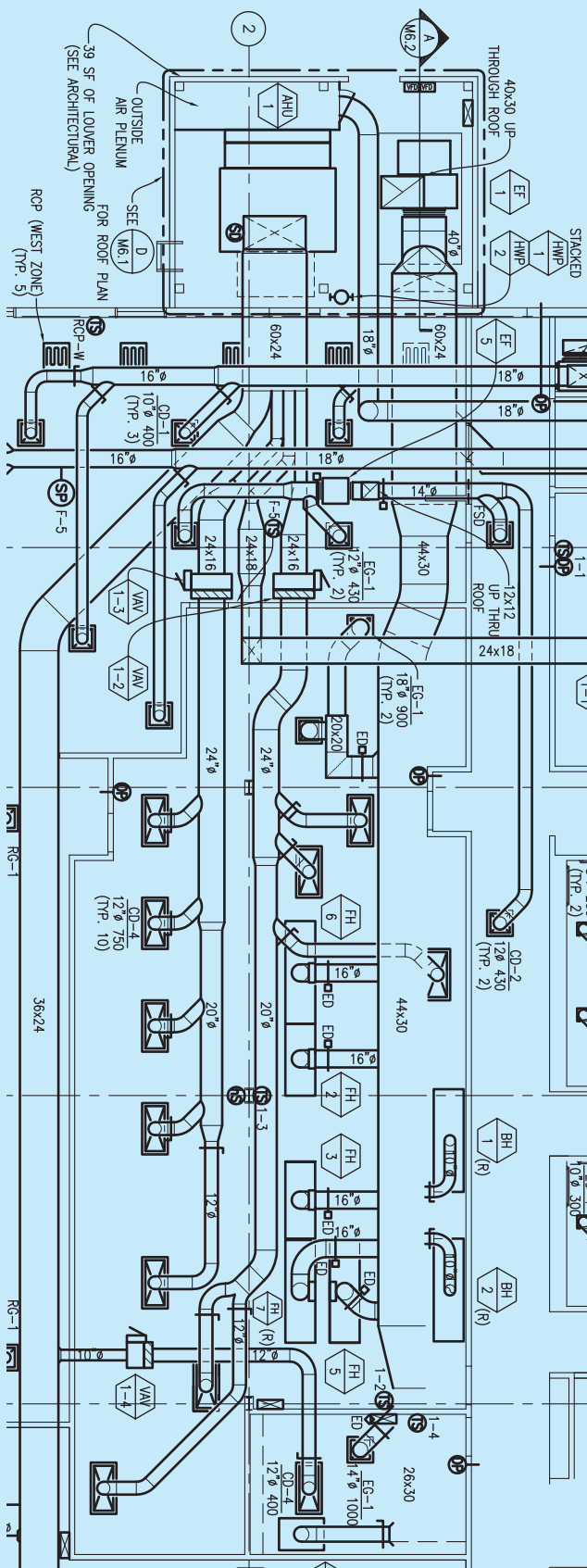
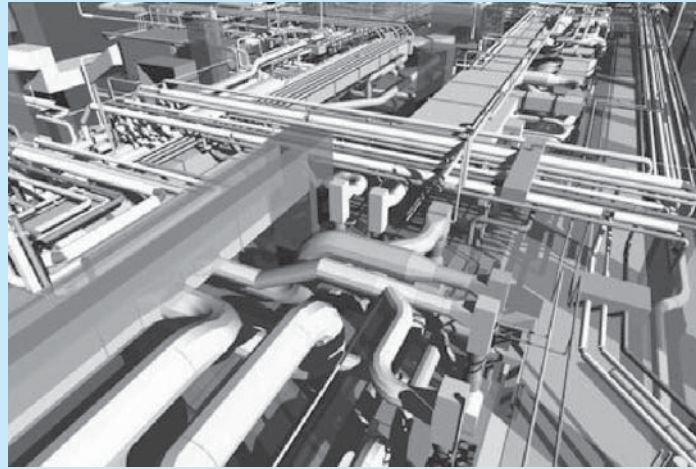


FIGURE 23.35 A partial HVAC plan created using CADD.

Courtesy of Brad Dotson, B&D Consulting

## HVAC MODELS

Three-dimensional CADD software provides designers and drafters with the ability to produce a realistic pictorial representation, or model, of an HVAC system. Figure 23.36 shows an example of a 3-D model complete with HVAC duct routing. An HVAC model offers several advantages over a 2-D HVAC plan. Probably the most obvious benefit of an HVAC model is the ability to visualize and communicate an HVAC system design by three-dimensionally viewing a model from any angle or orientation. A 3-D HVAC layout also greatly aids in the



Courtesy Pinnacle CAD

FIGURE 23.36 CADD-generated model of HVAC duct routing.

design of an HVAC system. For example, some CADD programs automatically analyze the HVAC layout for obstacles in which an error in design can result in a duct that does not have a clear path. This type of feature allows a 3-D model of an entire HVAC system to be designed and tested and coordinated with other trades before the actual structure is ever built. In addition, because of the parametric nature of many CADD applications, when changes are made to the HVAC model, the changes are corrected on all drawings, schedules, and lists of materials at the same time.

an engineer may require a higher FPM because the diffusers are high above the people in the room being conditioned, whereas in a theater an engineer may require a lower velocity to reduce the sound of the air traveling in the duct. Also, in a multizone system with air terminals, the high-pressure side of the system has a higher velocity than the low-pressure side. An air terminal is a variable air volume (VAV) box that regulates the amount of air going to a zone in a multizone system. The high-pressure side of a duct system is the duct between the air-handling unit (AHU) and the VAV. The low-pressure side is from the VAV to the diffuser in the ceiling or wall. The VAV slows the air down from the high-pressure side and only allows enough air through to the diffuser that is required. An AHU is usually a large metal box containing a blower, heating or cooling elements, filter racks or chambers, sound attenuators, and dampers. Air handlers usually connect to ductwork that distributes the conditioned air through the building and returns it to the AHU.

### The Effect of Aspect Ratio on Duct Sizing

**Aspect ratio** is the relationship between the length and width of a duct. For example, a  $12 \times 12$  duct has a 1:1 ratio because

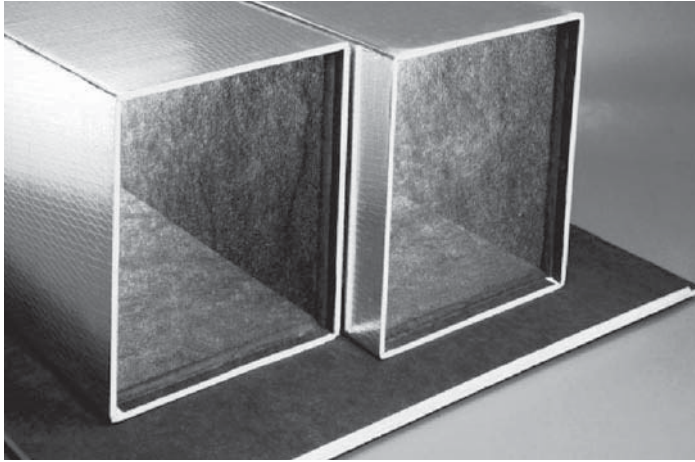
the relationship between the length (12) and the width (12) is 1 to 1, whereas a  $48 \times 12$  duct has a 4:1 aspect ratio because the relationship between 48 and 12 is 4 to 1. The optimal aspect ratio for the duct is 1:1 when sizing duct for air distribution. It is advisable not to exceed a 4:1 aspect ratio unless it is approved by the engineer.

### The Effect of an Acoustical Liner on Duct Sizing

When calculating the net inside area (NIA) of a duct, always account for acoustical liner. An **acoustical liner (AL)** is placed inside a duct to help reduce the sound caused by air moving through the duct. Acoustical liner is called out in the specifications or in the notes indicating the thickness of the liner. Figure 23.37 shows a typical acoustical liner insert. For example, a  $20 \times 20$  duct with 1" AL actually has an NIA of 324" instead of 400" because of 1" of area loss around the inside of the duct where air is traveling.

### Making Air-Duct Calculators

**Air-duct calculators** are very useful tools to use when sizing duct. You can use these calculations to find the proper duct size



**FIGURE 23.37** A typical acoustical liner insert, also referred to as a sound liner. © Cengage Learning 2012

based on the CFM or FPM. The calculations also make it very easy to find the square equivalent of a round duct or the round equivalent of a square duct.

### Air-Duct Sizing Formulas

Use the following formula to size a duct for the proper CFM:

$$\text{CFM} = \text{Area} \times \text{FPM}$$

Example: 12 × 12 duct at 750 FPM; 12 × 12 = 1 sq. ft.

$$1 \text{ sq ft} \times 750 \text{ FPM} = 750 \text{ CFM}$$

Use the following formula to change the shape of a duct from round to square:

$$\begin{aligned} \text{Area of a circle} &= \pi r^2 \\ \text{Area / length} &= \text{width} \end{aligned}$$

Example: Convert a 12" round duct to a 10" deep square or rectangular duct.

$$\begin{aligned} \text{Area of a 12 IN diameter circle} &= \pi 6^2 = 113 \text{ sq. IN (rounded)} \\ 113 / 10 &= 11.3 \end{aligned}$$

A 12" round duct = 10 × 11.3 rectangular duct. Use a 10 × 12 rectangular duct.

Use the following formula to change the shape of a duct from square to round:

$$2(\text{square root [area / } \pi]) = \text{diameter}$$

Example: Convert a 10 × 10 square duct to an equivalent round duct.

$$\begin{aligned} \text{Area} &= 10 \times 10 = 100 \text{ sq. IN} \\ 2(\text{square root [100/3.14159]}) &= 2(\text{square root [31.83]}) \\ &= 2(5.6418) = 11.28 \end{aligned}$$

A 10 × 10 square duct = 11.28" round duct. Use a standard 12" diameter duct.

### Duct Sizing Guidelines

- Calculate the area for square or rectangular using (length × width).
- Calculate the area for round using ( $\pi \times \text{radius}^2$ ).
- When calculating duct sizes, remember that ducts are not made in 11.5" round or 12.375" × 14.24" rectangular as a standard, so you need to round to the nearest even number for a size, resulting in a 12" round and a 12 × 14 rectangular duct.
- Whenever you change the size of a duct from the size indicated in the engineer's design, it should be with the intention of improving the constructability. Whenever possible, it is advisable to use the engineer's design unless you are unable to because of field conditions. If field conditions do not permit an engineered size, then you need to write a request for information (RFI) to inform the engineer about the change being made.
- A handheld air-duct calculator called Ductalator has formulas and calculations for duct sizing. The handheld air-duct calculator is available through Graphic Calculator Co., Barrington, Illinois 60010.



### Effect of Duct Shape on Duct Sizing

For information about how duct shape has an effect on duct sizing, go to the Student CD, select **Supplemental Material, Chapter 23**, and then **Effect of Duct Shape on Duct Sizing**.

## SHEET METAL DESIGN AND DRAFTING

Sheet metal drafting is found in any industry where flat material is used for fabrication into desired shapes. One of the most common applications is the HVAC industry, although sheet metal shapes are common in the automotive, electronics, and other related industries. Sheet metal drafting is also called *pattern development*.

### PATTERN DEVELOPMENT

The principle of pattern development is based on laying out geometric shapes in true size and shape flat patterns. The fundamental concepts involved in making patterns for basic geometric shapes can be used in the development of any pattern. In most situations, a front and top or bottom view is drawn to help establish true-length lines and true-size shapes. *The key to pattern development is any line or element used in the development must be in true length.* Do preliminary layout work on a construction layer.



## Descriptive Geometry

For complete information about Descriptive Geometry, go to the Student CD, select **Reference Material**, and then **Descriptive Geometry I** and **Descriptive Geometry II**.

### Seams and Hems

A **seam** is the line formed when two or more edges come together. When sheet metal parts are bent and formed into a desired shape, a seam results where the ends of the pattern come together. The fastening method depends on the kind and thickness of material, the fabrication processes available, and the end use of the part. Sheet metal components that must hold gases or liquid or that are pressurized can require soldering, brazing, or welding. Other applications can use mechanical seams, which hold the parts together by pressure lapped metal, metal clips, pop rivets, or other fasteners. Some of the most common seams used in the sheet metal fabrication industry are shown in Figure 23.38. Extra material can be required on the pattern to allow for seaming. For the purpose of discussion in the following procedures and problems, either a single- or double-lap seam is used. For a **single-lap seam**, add the given amount to one side of the pattern. For **double-lap seams**, add the given amount to both sides of the pattern. The corner of a seam can be cut off at an angle that is usually  $45^\circ$  if it interferes with adjacent parts during fastening.

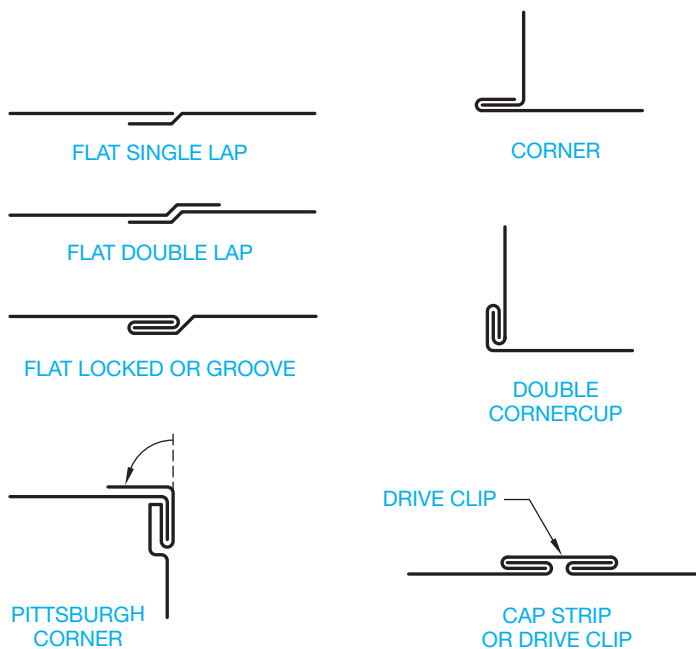


FIGURE 23.38 Common seams. © Cengage Learning 2012



FIGURE 23.39 Common hems. © Cengage Learning 2012

A **hem** provides extra material on the pattern for strength and connection at the seams. Hemmed edges are necessary when an exposed edge of a pattern must be strengthened. When hems are used, extra material must be added to the pattern on the side of the hem. Figure 23.39 shows some common hems.

### Starting with a Stretch-Out Line

A **stretch-out line** is typically the beginning line on which measurements are made and the pattern development is established. Carefully observe how the stretch-out lines are established for each of the following developments; this is the first process in making a layout. Specific developments that do not begin with a stretch-out line are identified. The instruction provided for the following pattern development is divided into basic procedures. Individual shortcuts can be taken after enough experience has been gained. It is extremely important to maintain a high degree of accuracy. Scale drawings and transfer dimensions very carefully.

Another important consideration is to accurately label the elements of the views with numbers or letters or both and then transfer these labels to the pattern. This procedure may seem unnecessary on simple developments, but on complex patterns it is absolutely necessary for organization purposes. It is recommended that beginners label all developments as suggested in the given procedures.

### Developing a Rectangular (Right) or Square Prism

Commonly referred to as a **box**, the **rectangular** or **right prism** can be developed using specific steps. An open-ended box is developed in this example as follows:

- STEP 1** Draw the front and top views, label the corners, and establish the stretch-out line off the base of the front view and perpendicular to the height line (see Figure 23.40).
- STEP 2** Beginning at 1 in the top view, measure the true-length (TL) distance from 1 to 2. Transfer this dimension to the stretch-out line, starting at any point near the front view. Continue this process by transferring the distance from 2 to 3, 3 to 4, and 4 to 1 to the stretch-out line (see Figure 23.41). You must end at the point where you began, which is point 1 in this example.
- STEP 3** From each of the points established in Step 2, draw vertical construction lines to meet a horizontal line drawn from the TL height in the front view (see Figure 23.42).

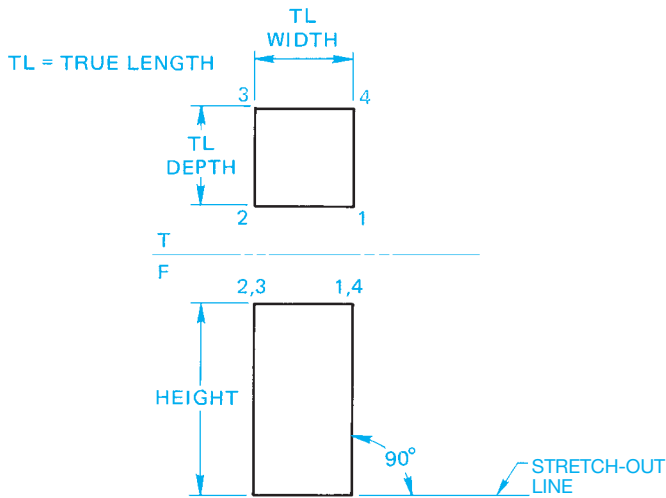


FIGURE 23.40 Step 1: Right prism development. © Cengage Learning 2012

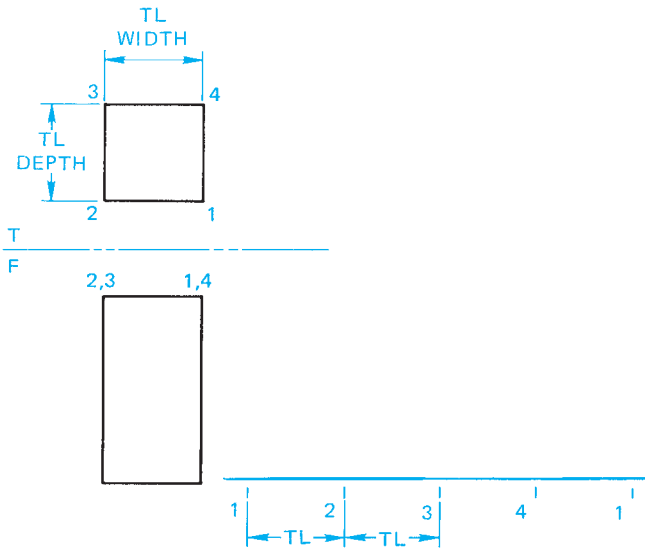


FIGURE 23.41 Step 2: Right prism development. © Cengage Learning 2012

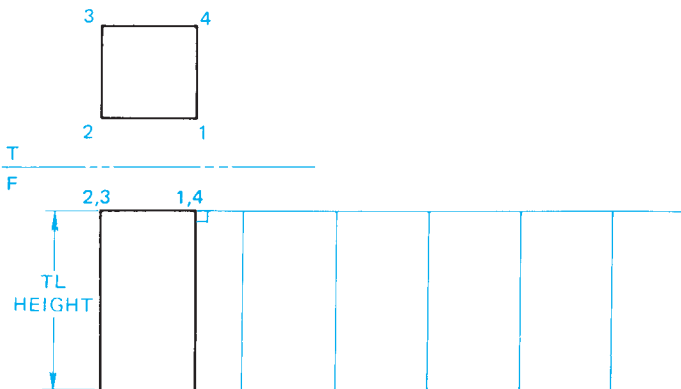


FIGURE 23.42 Step 3: Right prism development. © Cengage Learning 2012

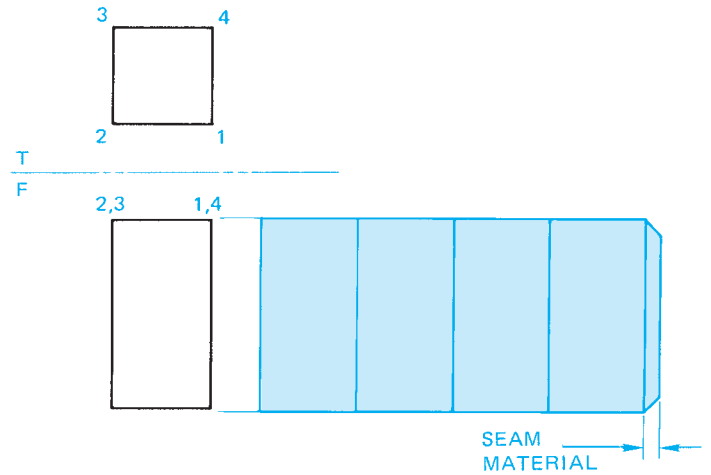


FIGURE 23.43 Step 4: Right prism development. © Cengage Learning 2012

**STEP 4** Draw visible object lines. Notice that thick visible object lines are used where the pattern sides make a bend. Add any required seam material (see Figure 23.43). The pattern is now ready to be cut out and formed into the given shape or transferred to sheet metal for fabrication.

### Truncated Prism Pattern Development

A sheet metal part such as a prism, pyramid, or cone is considered to be **truncated** if a portion is cut off, generally at an angle. The following steps are used to create a truncated prism pattern development:

**STEP 1** Proceed as described in Steps 1 through 3 for a right prism. When possible, begin with the shortest element as the seam. The shortest seam is stronger, is easier to fabricate, and requires less materials. This is true for all pattern development applications (see Figure 23.44).

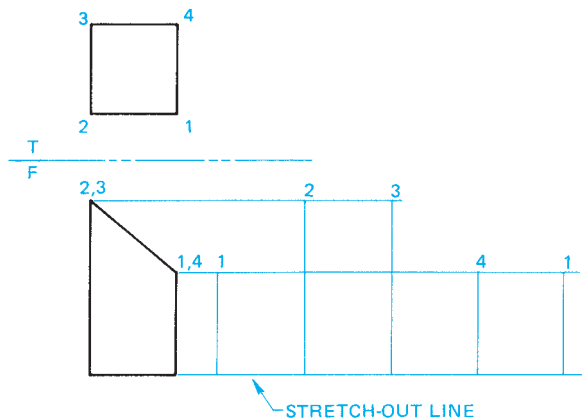


FIGURE 23.44 Step 1: Truncated prism development.

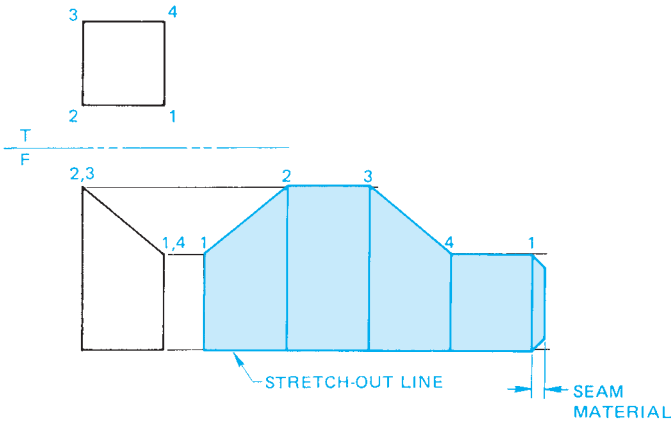


FIGURE 23.45 Step 2: Truncated prism development. © Cengage Learning 2012

**STEP 2** Draw visible object lines by connecting the ends of the true-height elements to form the outline of the object. Draw all bend lines and add seam material as shown in Figure 23.45.

## Developing a Regular (Right) Cylinder

A regular right cylindrical object is a cylinder that has its sides perpendicular to the base. One of the most common sheet metal shapes is the cylinder. The following procedure can be used for the development of any right cylindrical shape:

**STEP 1** Draw the top and front views. Establish the stretch-out line perpendicular to the side of the front view. The stretch-out line can be placed anywhere next to the front view, but it must be perpendicular to the side (see Figure 23.46).

**STEP 2** Establish the length of the stretch-out line equal to the circumference of the circle using the formula  $C = \pi D$ . The diameter is .88 IN, so  $C = 3.14(\pi) \times .88 = 2.76$  IN. Now, from the ends of the stretch-out line, draw

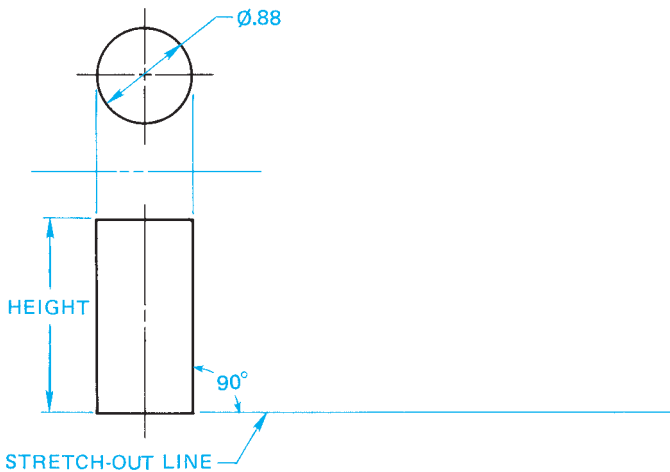


FIGURE 23.46 Step 1: Right cylinder development. © Cengage Learning 2012

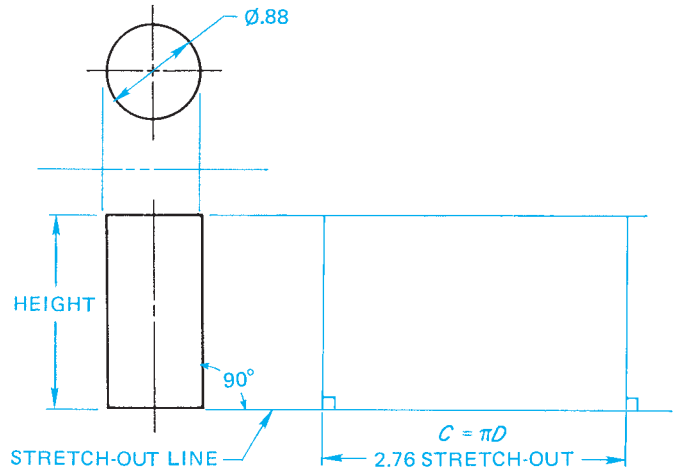


FIGURE 23.47 Step 2: Right cylinder development. © Cengage Learning 2012

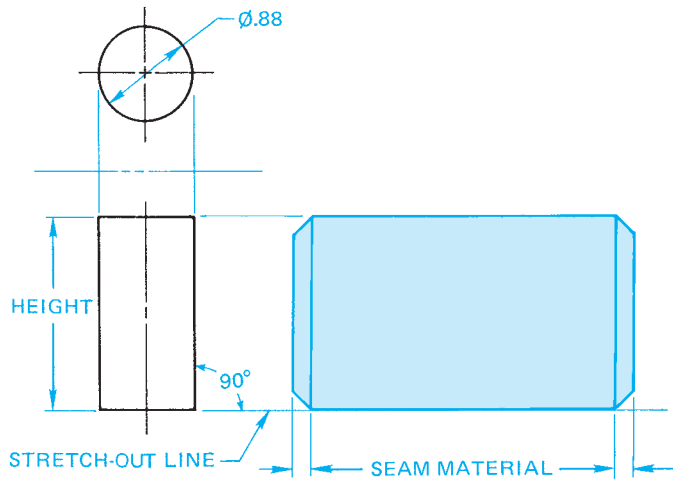


FIGURE 23.48 Step 3: Right cylinder development. © Cengage Learning 2012

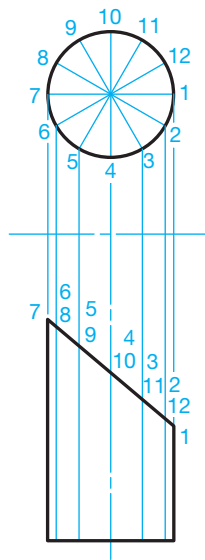
perpendicular lines that meet a line projected from the true height in the front view as shown in Figure 23.47.

**STEP 3** Draw the outline of the pattern and add seam material as shown in Figure 23.48. This example uses a double-lap seam.

## Truncated Cylinder Pattern Development

Truncated means to cut a geometric shape or object off at an angle with a plane. Truncated cylinders have many HVAC applications with development procedures similar to the regular cylinder. Use the following steps to create a truncated cylinder pattern development:

**STEP 1** Draw the top and front views. Divide the top view into 12 equal parts. More divisions establish better accuracy, and fewer divisions give less accuracy. Twelve divisions have been selected because of ease and effectiveness. Number each element in the top



© Cengage Learning 2012

FIGURE 23.49 Step 1: Truncated cylinder development.

view and extend the numbering system into the front view (see Figure 23.49).

**STEP 2** Establish the stretch-out line perpendicular to the side of the front view and the length with the formula  $C = \pi D$  as previously discussed. Divide the stretch-out into 12 equal parts. Number each part from 1 through 12, ending at 1 where the seam is located. From each part on the stretch-out line, draw a perpendicular construction line equal to the total height of the cylinder (see Figure 23.50). The AutoCAD DIVIDE command is used to divide a given line into equal parts, for example.

**STEP 3** Project the true height of each line segment in the front view to the correspondingly numbered line in the

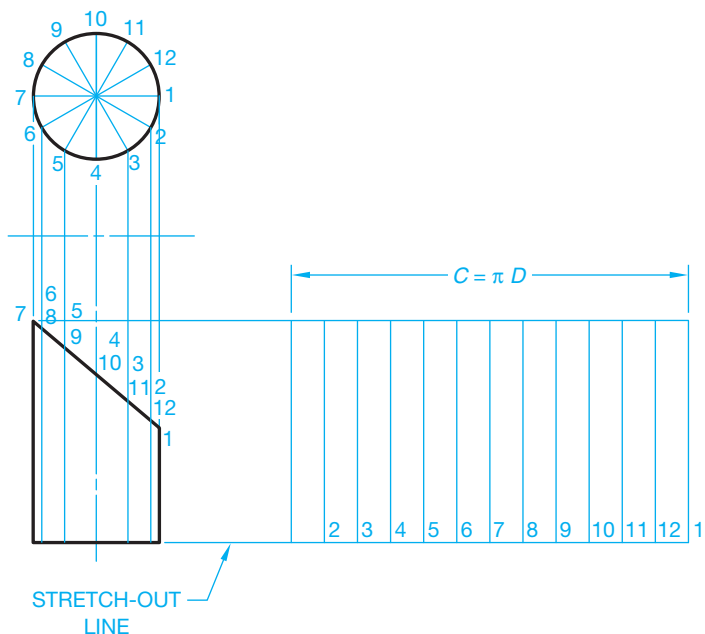


FIGURE 23.50 Step 2: Truncated cylinder development. © Cengage Learning 2012

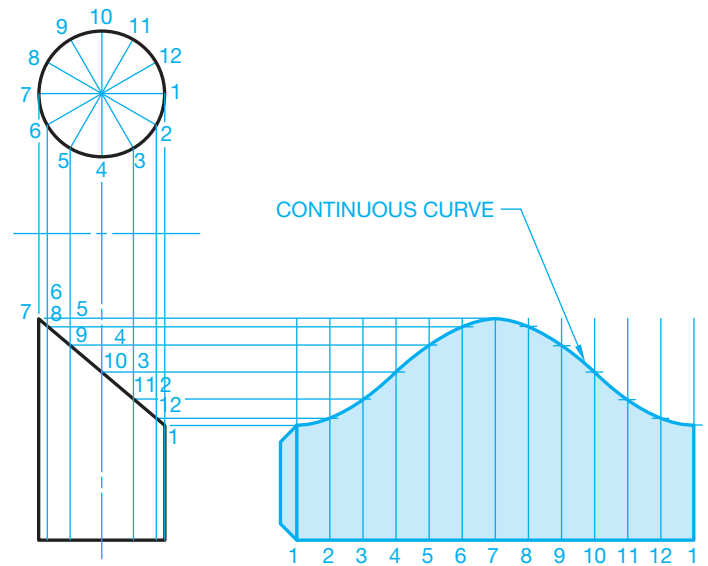


FIGURE 23.51 Step 3: Truncated cylinder development. Courtesy W. Alan Gold Consulting Mechanical Engineer and Robert Evenson Associates AIA Architects

pattern layout. Where these lines intersect, a pattern of points is established. Connect the points forming the curved outline of the truncated cylinder pattern. Draw the outline of the pattern and add seams. The division lines can be drawn as thin lines to represent a curved object. Turn off or freeze the construction layer when using CADD (see Figure 23.51). When using AutoCAD, a polyline can be drawn to connect the points and the spline fit tool used to create a smooth contour.

When the cylinder is truncated on both ends, the process is the same, with the stretch-out line established perpendicular to the side at any desired location (see Figure 23.52).

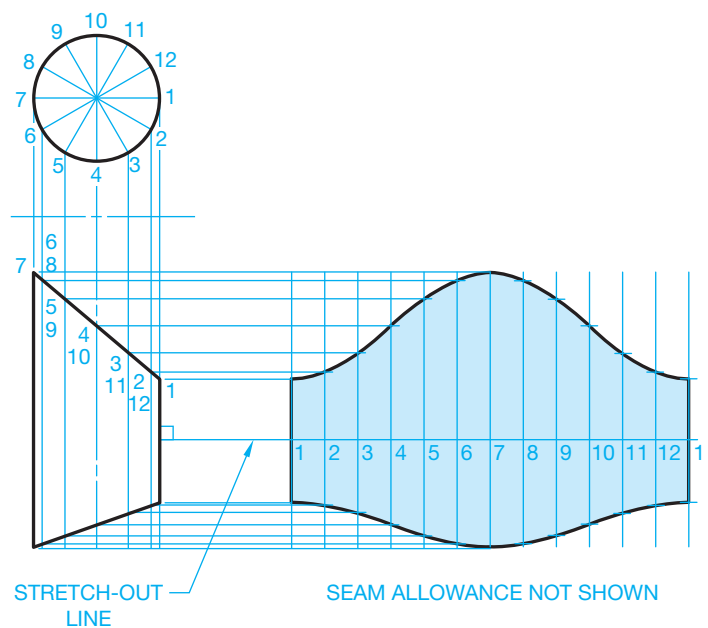


FIGURE 23.52 Development of cylinder truncated on both ends. © Cengage Learning 2012



## Developing a Cylindrical Elbow

**Cylindrical elbows** are used to make turns or corners in ductwork. A cylindrical elbow is also called an *elbow*, a *90° elbow*, or a *right elbow* when the elbow makes a 90° turn. Other elbows can be designed that make turns other than 90°, such as a 45° elbow, or any desired number of degrees. Standard cylindrical elbows are made of any given number of truncated cylinders. Each piece of the elbow can be developed as demonstrated in the previous discussion. Figure 23.53 shows standard three-piece and four-piece 90° elbows. Each piece of the three-piece elbow is developed as a truncated cylinder, with the patterns developed separately or together by alternating starting elements as shown in Figure 23.54.

## Developing a Cone

The size of the cone is established by the base diameter, and the height can be developed as follows:

**STEP 1** Given the height and base diameter, draw the front and top or bottom views. Divide the top or bottom view into 12 equal parts. Number each part and

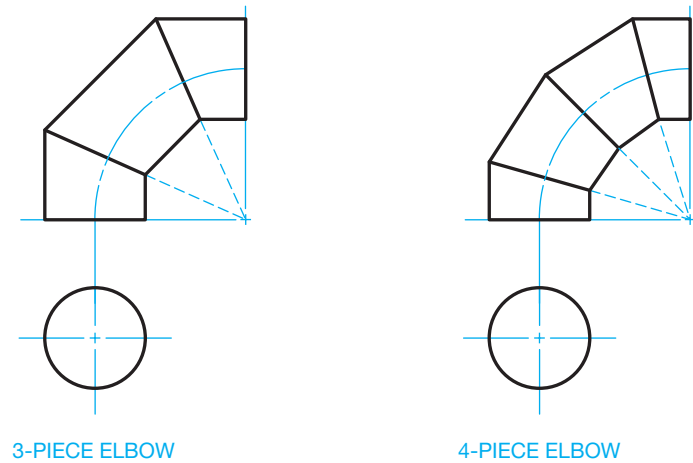


FIGURE 23.53 Standard 90° elbows. © Cengage Learning 2012

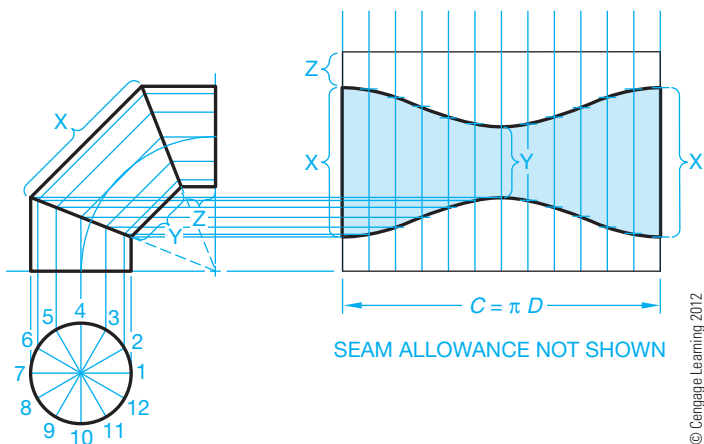


FIGURE 23.54 Development of a three-piece cylindrical elbow.

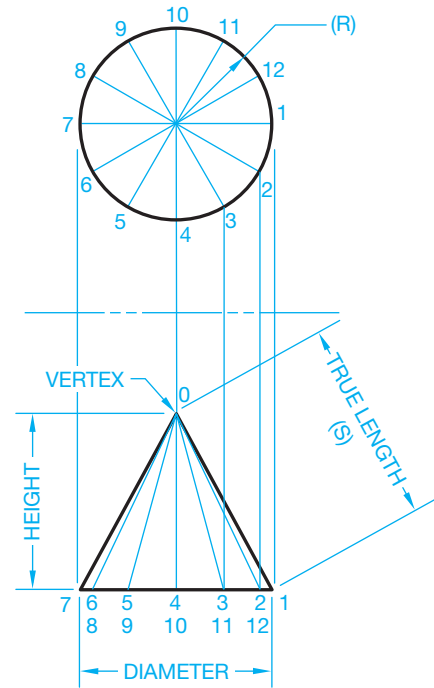


FIGURE 23.55 Step 1: Cone development.

project these to the cone base in the front view. At the base in the front view, extend each point to the vertex of the cone (see Figure 23.55).

**STEP 2** The stretch-out line for a right circular cone development is a true circular arc. The radius of the arc is taken from the true-length element measured from zero to one in the front view (see Figure 23.55). With the center at any convenient location where you have enough space, draw an arc with the true-length radius (see Figure 23.56).

**STEP 3** Go to the top view and establish the increment from point 1 to point 2 (see Figure 23.55). Beginning at any point on the stretch-out line, use the established increment to locate 12 equal spaces. Remember, if you begin at 1, you must end at 1. Now connect each point along the stretch-out line to the vertex 0 with construction lines (see Figure 23.56). The AutoCAD

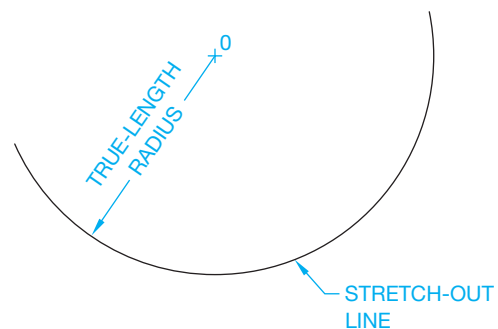
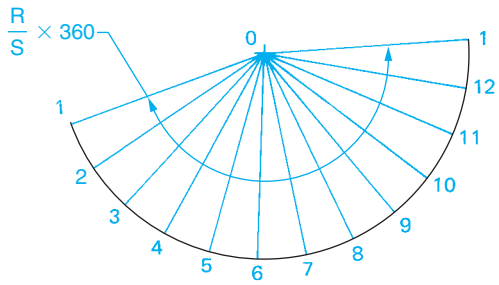
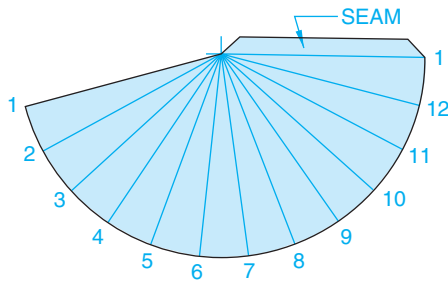


FIGURE 23.56 Step 2: Cone development.



© Cengage Learning 2012

FIGURE 23.57 Step 3: Cone development.



© Cengage Learning 2012

FIGURE 23.58 Step 4: Cone development.

MEASURE and QCAL commands can be used to establish the circumference on the stretch-out line followed by the DIVIDE command to find the 12 equal spaces. Alternately, the angle forming the sides of the cone, in the Figure 23.57 pattern layout, can be calculated using the formula:  $R/S \times 360$ , where R is the radius of the cone base, and S is the true length of the side of the cone as shown in Figure 23.55.

**STEP 4** Draw the outline of the cone pattern and add seam material as necessary (see Figure 23.58).

### Truncated Cone Pattern Development

The procedure for developing a truncated cone begins the same as the regular cone previously described. Always start by developing a pattern for a full regular cone. After Step 3, the true length of each line segment from the vertex to the truncated line in the front view must be established. Project each point to the true-length line. Then measure the true length of each element from the vertex along the true-length line as shown in Figure 23.59. Transfer the true length of each individual line to the corresponding line in the pattern development (see Figure 23.59). Finally, draw the outline by connecting the points to form the curve. Add seam material if required as shown in Figure 23.59.

### Developing an Offset Cone

The offset cone has the vertex offset from the center of the base. The procedure is slightly different from the development

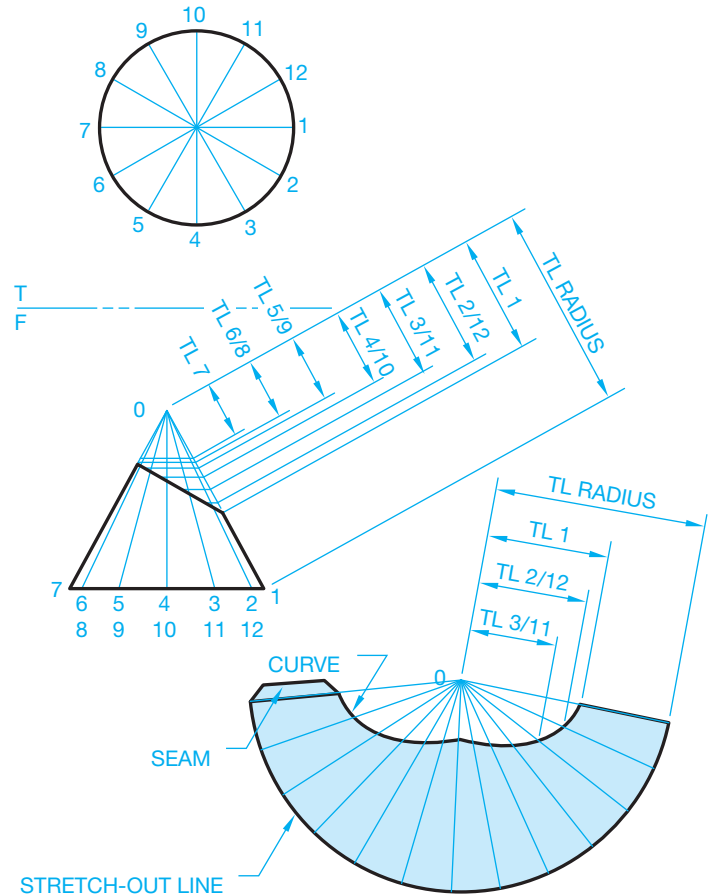


FIGURE 23.59 Truncated cone development. © Cengage Learning 2012

of a regular cone, because the true length of each line element must be found. Refer to Figure 23.60 as you read the following instructions:

- STEP 1** Draw the top and front views. Divide the top view base circle into 12 equal parts. Project each point to the vertex and establish the same elements in the front view.
- STEP 2** The true lengths of elements 0–1 and 0–7 are true length in the front view. Use a construction layer for layout work. Establish the true-length diagram for the other elements using the revolution method as shown in color in Figure 23.60.
- STEP 3** There is no stretch-out line in this development. Begin the development by laying out the true length of element 0–7 in a convenient location. Lay out the true length of 0–6 and 0–8 on each side of 0–7. Use the distance X in the top view to layout the base measurements. You can calculate this measurement using the formula  $C = \pi D \div 12$ . Use the distance X as a radius and set the center at 7 and draw an arc that intersects the arcs drawn for 0–6 and 0–8. This procedure locates the exact position of elements 0–6 and 0–8. Follow this same method for each of the elements 0–5 and 0–9, 0–4 and 0–10, 0–3 and 0–11,

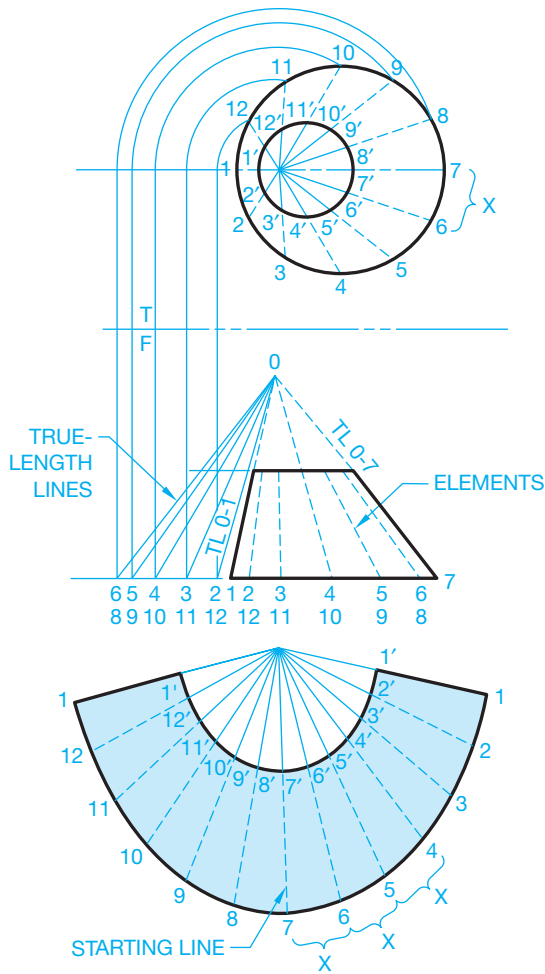


FIGURE 23.60 Offset cone development.

0–2 and 0–12, and 0–1 at each end. You now have a series of points along the base that can be connected with a curve.

**STEP 4** The true lengths of elements 0–1 and 0–7 are in the front view. Use the true-length diagram to establish the true lengths of the other elements, 0–2 through 0–12. Transfer these true lengths to the corresponding elements in the development and connect the points with a curve. Draw the outline and add seam material if required (see Figure 23.60).

## Developing a Pyramid

Pyramids are developed in a manner similar to a cone as described in the following steps:

**STEP 1** Draw the top and front views and establish the true length of the edge of a side 0–1. Use a radius equal to the true length 0–1 and draw an arc in a convenient location. This arc is the stretch-out line (see Figure 23.61).

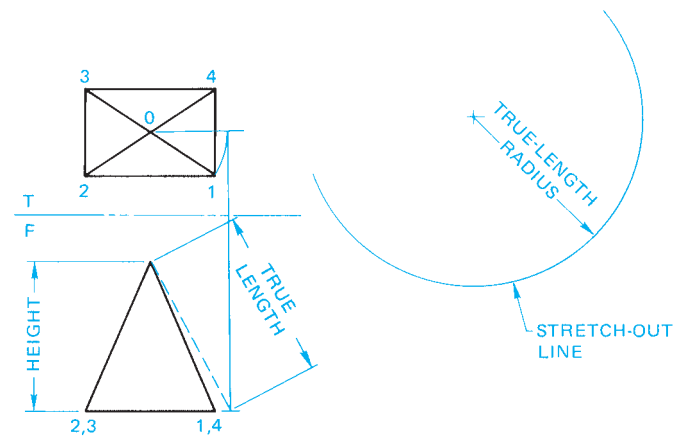


FIGURE 23.61 Step 1: Right pyramid development. A right pyramid has the vertex (0) centered over the base.

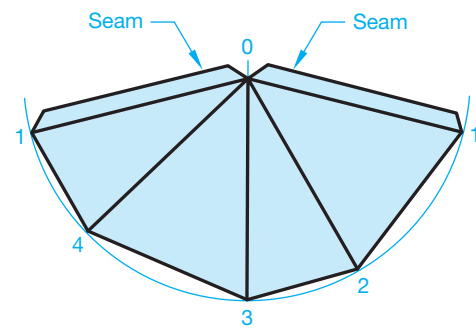


FIGURE 23.62 Step 2: Pyramid development.

**STEP 2** Measure the true lengths from points 1–2, 2–3, 3–4, and 4–1 in the top view and transfer these distances one after the other to the stretch-out line. Connect points 1, 2, 3, 4, and 1 in the development and also connect these points to the vertex 0. Draw all visible object lines and add seam allowances as shown in Figure 23.62.

## Pattern Development of a Truncated Pyramid

The procedure for the development of a truncated pyramid is the same as for a regular pyramid except the true length of each element from the vertex to the truncated line must be established and transferred to the pattern as shown in Figure 23.63.

## Drawing a Transition Piece Pattern Development

A **transition piece** is a duct component that provides a change in shape from square or rectangular to round. A transition piece is also known as a **square to round**, because of the

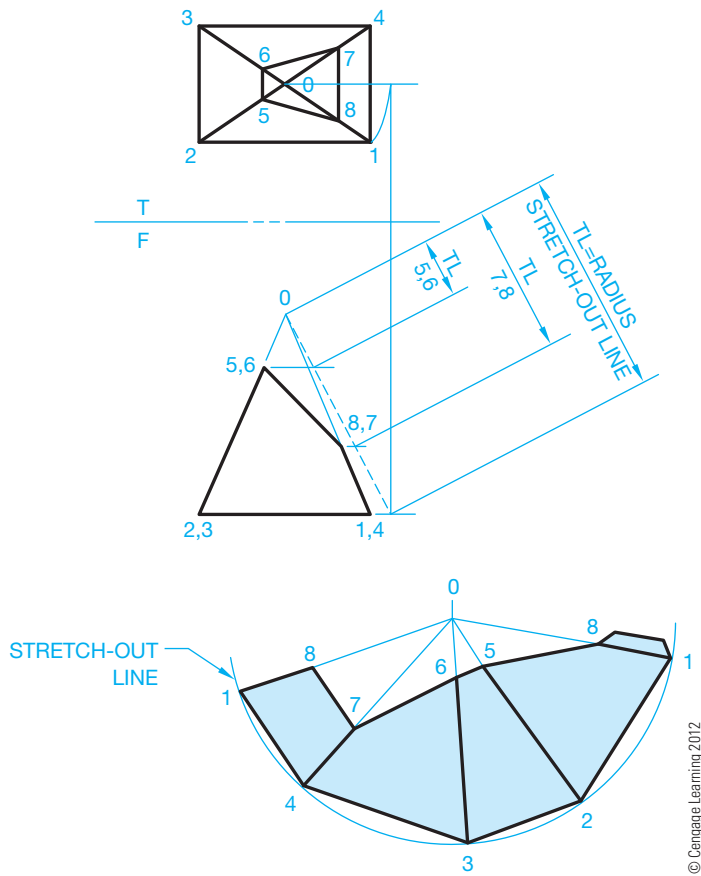


FIGURE 23.63 Truncated pyramid development.

transition it makes from a square or rectangular shape to a round shape. Transition pieces can be designed to fit any given situation, but the pattern development technique is always as follows.

**NOTE:** The use of a number and letter system is very important in order to keep track of the components. Do all layout work using construction lines on a construction layer. There are other techniques that work in some unique situations, but the method described here works with any transition piece configuration.

**STEP 1** Draw the top and front views. Divide the circle in the top view into 12 equal parts. Connect the points in each quarter of the circle to the adjacent corner of the square. Project the same corresponding system to the front view. Number and letter each point in each view as shown in Figure 23.63. The transition piece shown in Figure 23.64 is made up of a series of triangles. For example, 1,A,D; 1,2,A; and 2,3,A are triangles. The pattern development progresses by attaching the true size and shape of each triangle together in sequential order. This technique is known as **triangulation**. There is no stretch-out line for a transition piece when using this process.

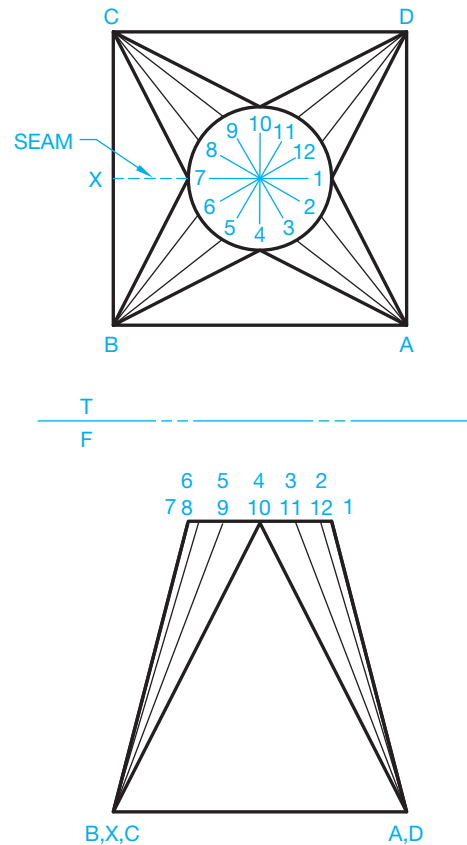


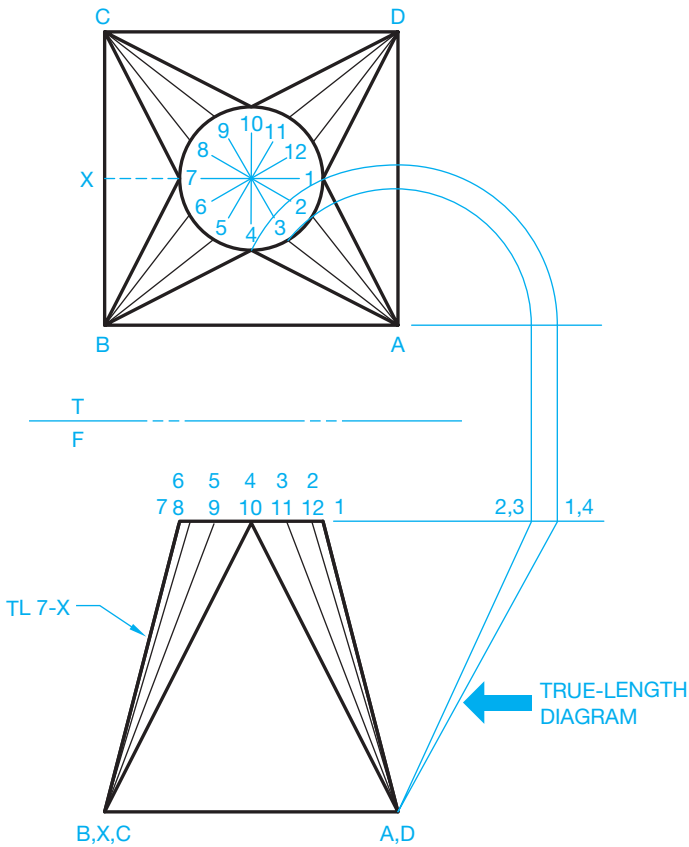
FIGURE 23.64 Step 1: Right transition piece view setup. A right transition piece has the circle centered over the base.

**STEP 2** Each element of the development must be in true length. Establish the true-length diagram using revolution as shown in Figure 23.65. Only one set of true-length elements is required because the given problem is a right transition piece that is symmetrical about both axes.

**STEP 3** Begin the pattern development in an area where there is a lot of space. Start with the true size and shape of triangle 1,A,D. The true lengths of 1-A and 1-D are the same and can be found in the true-length diagram. The true length of A-D is in the top view (see Figure 23.66). A review of Chapter 7, *Drafting Geometry*, and *Descriptive Geometry I* and *Descriptive Geometry II* on the Student CD can be helpful.

**Descriptive Geometry**

For complete information about finding true-length lines and true size and shape of surfaces, go to the Student CD, select **Reference Material**, and then **Descriptive Geometry I** and **Descriptive Geometry II**.



THE FOLLOWING TRUE LENGTHS ARE THE SAME FOR THIS RIGHT TRANSITION PIECE:

GROUP I	GROUP II
1-A	2-A
4-A	3-A
4-B	5-B
7-B	6-B
7-C	8-C
10-C	9-C
10-D	11-D
1-D	12-D

FIGURE 23.65 Step 2: Transition piece development. True-length diagram.

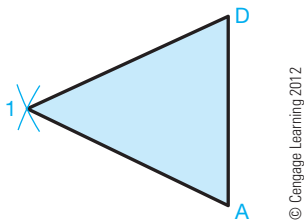


FIGURE 23.66 Step 3: Transition piece development. This is the triangulation, true size, and shape of the starting triangle.

**STEP 4** Work both ways from triangle 1,A,D in Figure 23.66 to develop the adjacent triangles. From points A and D, draw arcs equal to A-2 and D-12, respectively. Establish the distance from 1-2 using the formula  $C = \pi D \div 12$ . This value is used several times. With

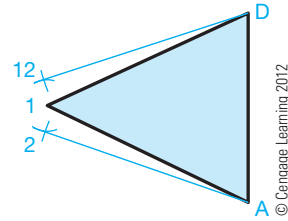


FIGURE 23.67 Step 4: Transition piece development. Continue the pattern development both ways from the starting triangle.

the 1-2 setting, draw two arcs from point 1 that intersect the previously drawn arcs. These intersections are points 2 and 12. Connect points 2-A and 12-D. Do not connect points 1,2 and 12 yet (see Figure 23.67). Do all work with construction lines until complete.

**STEP 5** Continue the same procedure, working both ways around the transition piece until the entire development is complete. Every triangle must be included, and the pattern ends on both sides with the element 7-X, which is true length in the front view. The two final triangles are right triangles, because the full side is an equilateral triangle and half of an equilateral triangle is a right triangle. Remember that every line transferred from the views to the pattern must be true length. It is recommended that the numbering system be used to avoid errors. Draw the outline using visible object lines when all points have been established. A series of points form the inside curve. Connect these points to create the curve. If any point is out of alignment with the others, you have made an error at this location. Notice in Figure 23.68 that visible object

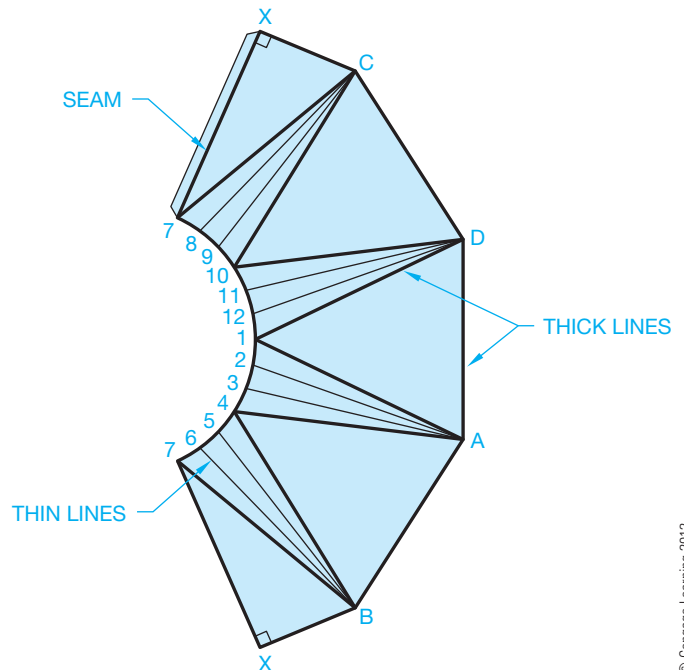
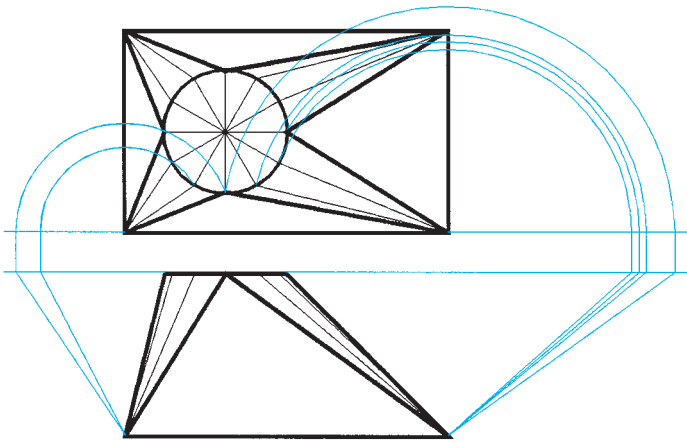


FIGURE 23.68 Step 5: Complete the transition piece development.

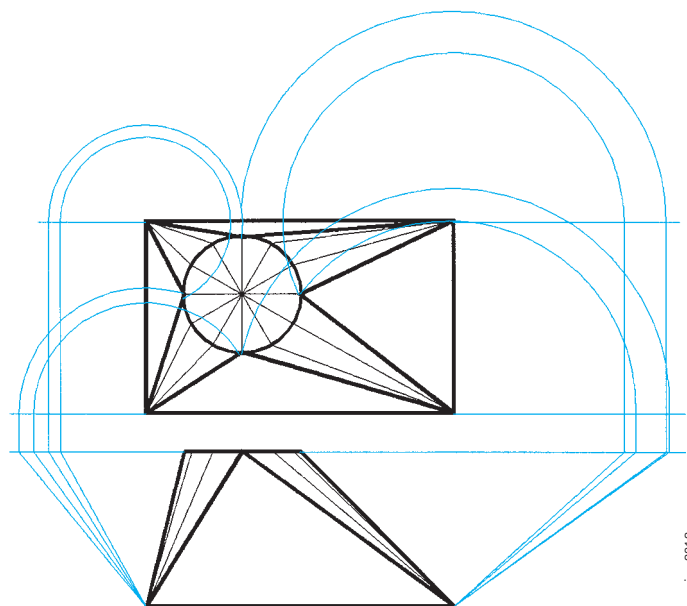


**FIGURE 23.69** Setting up a symmetrical offset transition piece. Two true-length diagrams are required. © Cengage Learning 2012

lines in the pattern are either outlines or bend lines, whereas thin lines form a smooth curve or contour. Cut out your pattern and see for yourself how it fits together.

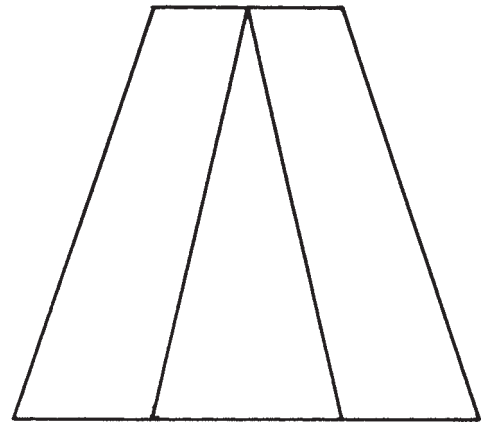
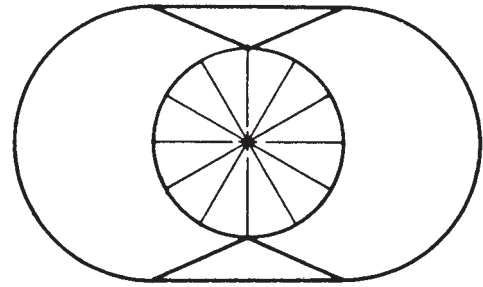
The right transition piece used in the previously described process is the easiest transition to develop because it is symmetrical. True-length diagrams are required for both halves if the round is offset as shown in Figure 23.69.

When the round is offset, as in Figure 23.70, true-length diagrams are necessary for the elements on each quarter of the transition. A numbering system and accurate work are very important when developing these more complex transitions. Colored lines can be used to help keep true-length diagrams clearly separate.



ONLY THE TRUE LENGTHS OF QUADRANT ELEMENTS ARE SHOWN FOR CLARITY

**FIGURE 23.70** Setting up an offset transition piece. Four true-length diagrams are required.



**FIGURE 23.71** Curve-to-curve transition.

### Curve-to-Curve Triangulation

Triangulation is a technique that is used for the development of transition pieces or any other pattern in which a series of triangles is used to form the desired shape. Figure 23.71 shows a part that makes a transition from one curved shape to another curved shape. In this situation, the adjacent curves are divided into a series of triangles before the pattern can be developed. The triangles help define one shape in relationship to the other (see Figure 23.72). First, draw the front and top views. After the views have been drawn, the following procedure is similar to the development of a transition piece:

- STEP 1** The part is symmetrical, so one set of true-length lines must be established (see Figure 23.73). Be careful when laying out and numbering the true-length lines. The use of colored lines can be helpful to keep elements coordinated. A numbering system and accuracy are critical for this type of problem.
- STEP 2** After the true-length elements have been established, the development technique is the same as developing the transition piece (see Figure 23.74).

### ESTABLISHING INTERSECTIONS

When one geometric shape meets another, the line of intersection between the shapes must be determined before the pattern of each piece can be developed. The key to determining the

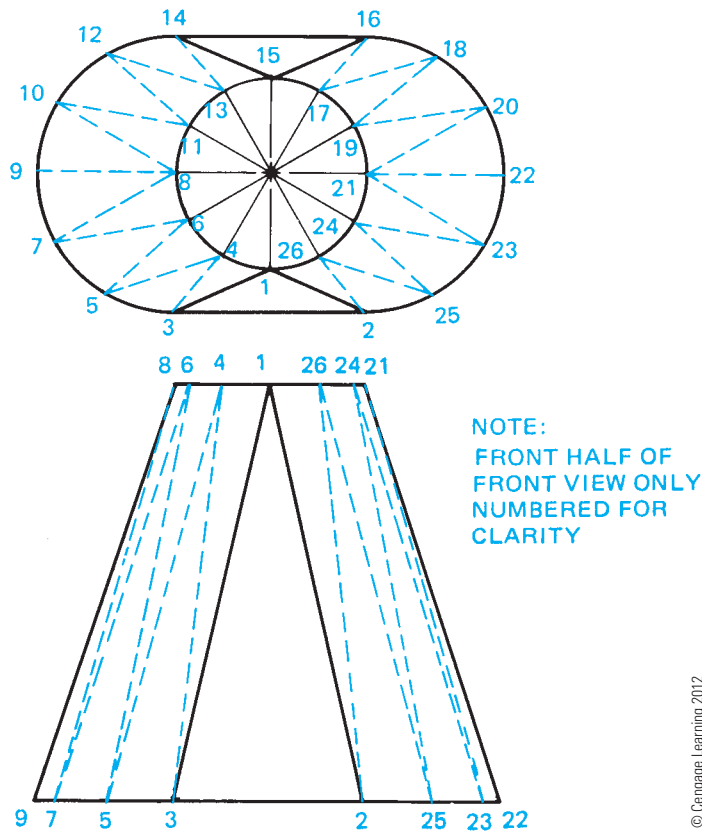


FIGURE 23.72 Setting up the triangulation on a curve-to-curve transition.

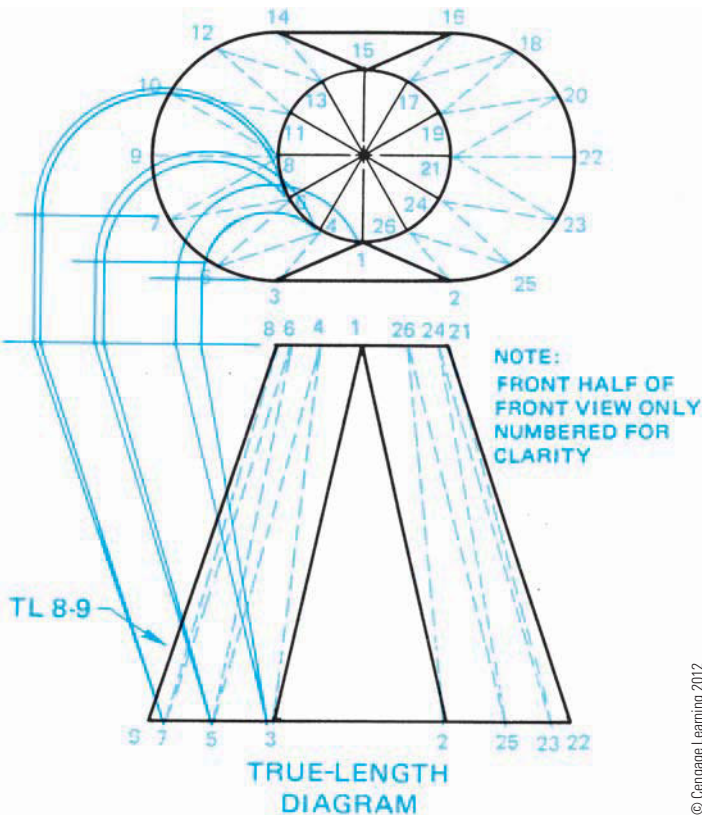


FIGURE 23.73 Step 1: Curve-to-curve transition. True-length diagram.

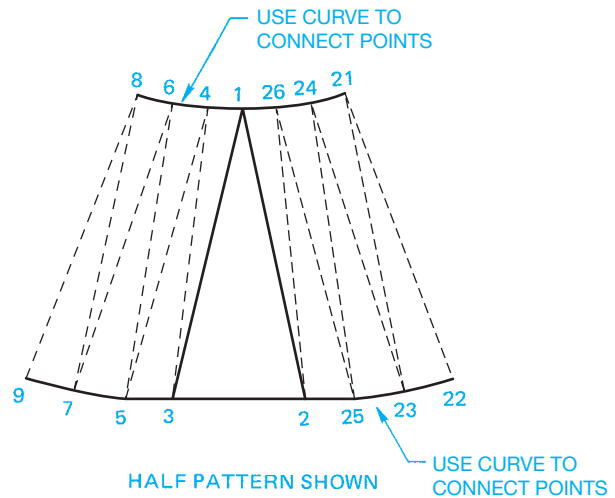


FIGURE 23.74 Step 2: Curve-to-curve transition development. A half pattern is shown in this example.

intersection between parts is setting up views with numbered true-length elements that correlate between views. The points of intersection of line elements at planes can then be projected between views.

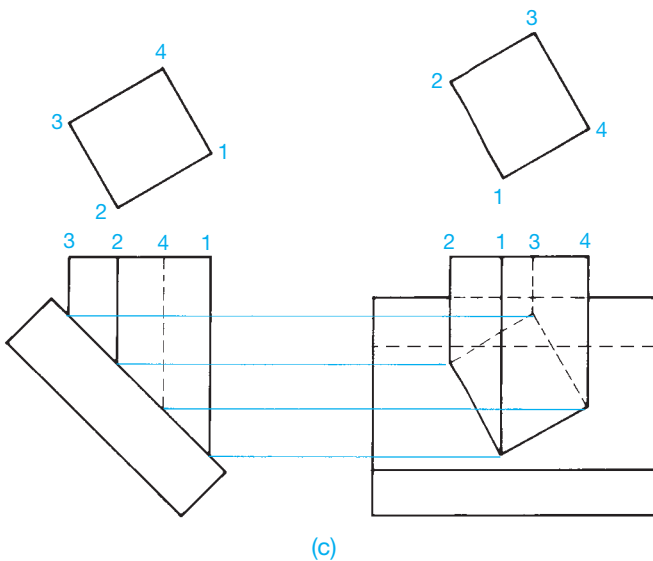
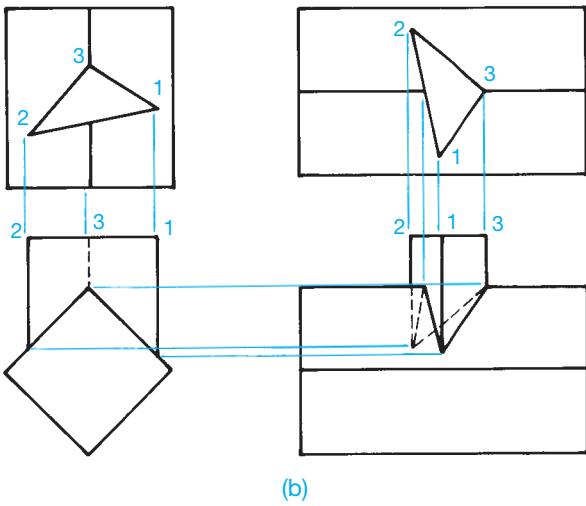
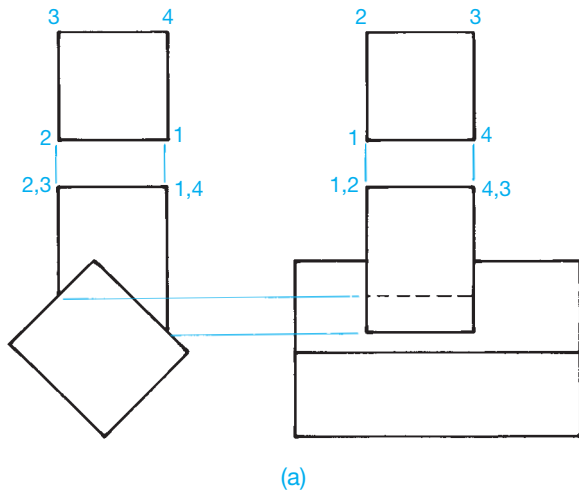
### Intersecting Prisms

The line of intersection between intersecting prisms can be found by projecting the true lengths of individual line elements between views. The corresponding points of intersection where lines intersect planes establish a series of points that are connected to form the lines of intersection. Several examples are shown in Figure 23.75. After the lines of intersection are determined, the pattern development can be made of the resulting shape.

### Intersecting Cylinders

The line of intersection between intersecting cylinders is determined in a manner that is similar to that for intersecting prisms. A series of line elements is established on the intersecting cylinder. Points of intersection of these line elements are then plotted. When the points are connected, the line of intersection is formed. The following procedure provides a typical example:

- STEP 1** Establish two adjacent views and show the circular view of the intersecting cylinder in both views. Divide the circular views of the intersecting cylinder into 12 equal parts in each view and number the points correspondingly. Be sure that your numbering system correlates between views as shown in Figure 23.76.
- STEP 2** Project point 1 in the circle above the front view down until it meets the intersecting circle. Where this element meets the intersecting circle, project across to the side view until it meets the same corresponding

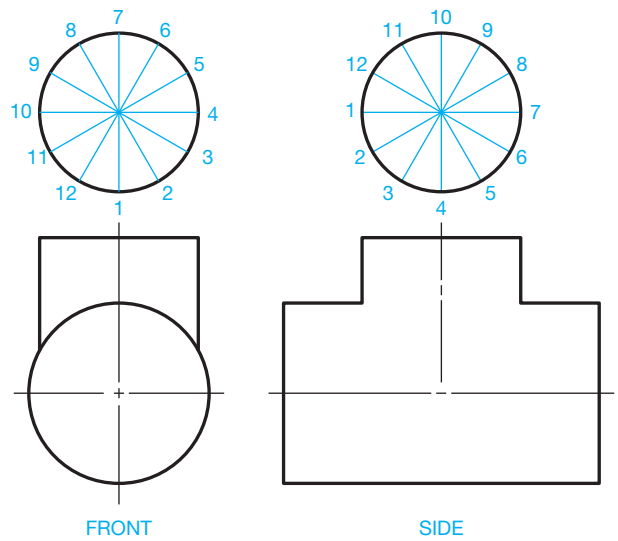


**FIGURE 23.75** Establishing the line of intersection between intersecting prisms. (a) Intersecting rectangular prisms. (b) Intersecting triangular and rectangular prisms. (c) Intersecting a rectangular prism on the plane surface of a rectangular prism. © Cengage Learning 2012

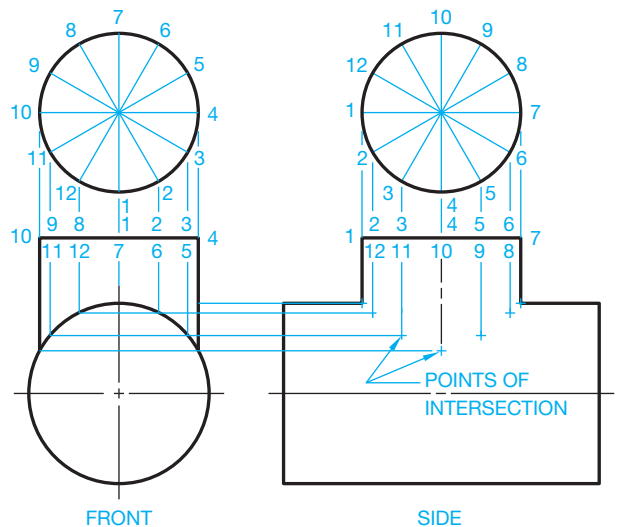
point 1 projected down from the circle above the side view. This is the point of intersection for line element 1. Follow the same procedure for each of the other 11 points. When complete, you have a series of points of intersection as shown in Figure 23.77.

**STEP 3** Connect the points of intersection in the side view to establish the line of intersection as shown in Figure 23.77. Now pattern developments of each cylinder can be made as described earlier in this chapter and as shown in Figure 23.78.

No matter how the intersecting cylinders are arranged, the technique is the same for establishing the line of intersection between the cylinders and the resulting pattern developments. The circular views are always drawn looking into the



**FIGURE 23.76** Step 1: Setting up intersecting cylinders.



**FIGURE 23.77** Step 2: Establishing points of intersection for intersecting cylinders.



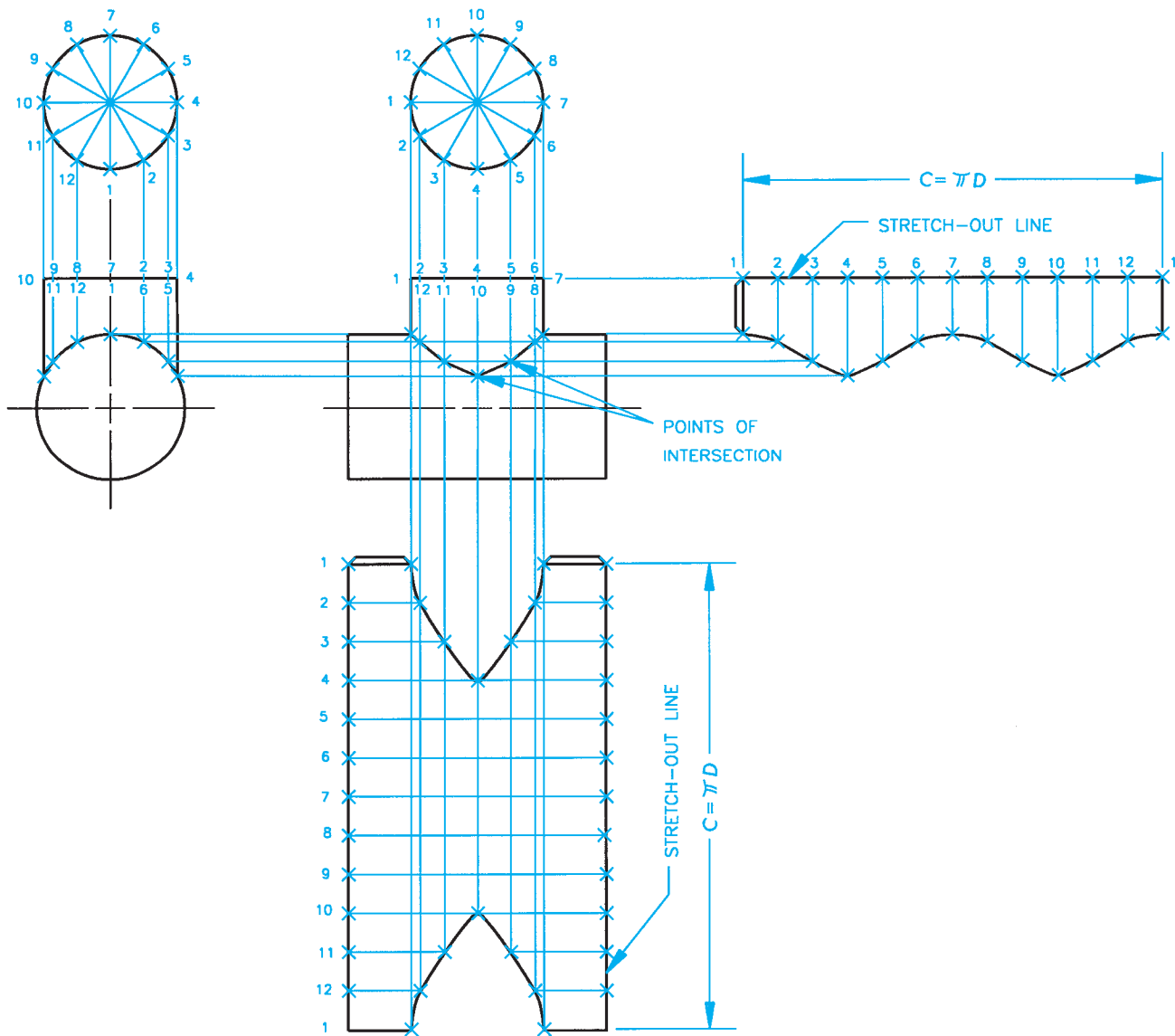


FIGURE 23.78 Step 3: Line of intersection for intersecting cylinders and the pattern development for both cylinders. © Cengage Learning 2012

intersecting cylinders, even when the cylinders intersect at an angle as in Figure 23.79. When the cylinders are offset, the back half of the intersecting cylinder appears hidden as shown in Figure 23.79. This example also shows how the patterns for the cylinders are drawn.

### Cylinder Intersecting Cone

The procedure used to find the line of intersection between a cylinder and a cone is more complex, but it can be done given any situation using the following steps:

**STEP 1** Draw the front and top views. Draw the circular view of the intersecting cylinder in both views and divide these circles into 12 equal parts. Number the parts of each circle so the numbering system correlates

between views (see Figure 23.80). Use construction lines on a construction layer for all layout work.

**STEP 2** Beginning with point number 1 in the circle adjacent to the front view, project this point until it intersects the true-length element of the cone, 0–X. This is the point of intersection of point 1 in the front view. From this point of intersection, project to the top view until the projection meets the same corresponding point projected from the circle adjacent to the top view. This is the point of intersection of point 1 in the top view (see Figure 23.81).

**STEP 3** Now project point 2 from the circle adjacent to the front view to the true-length element of the cone, 0–X in the front view. Points 2 and 12 are on the same projection line if the object is symmetrical. From this point, project point 2 into the top view until intersecting 0–X.

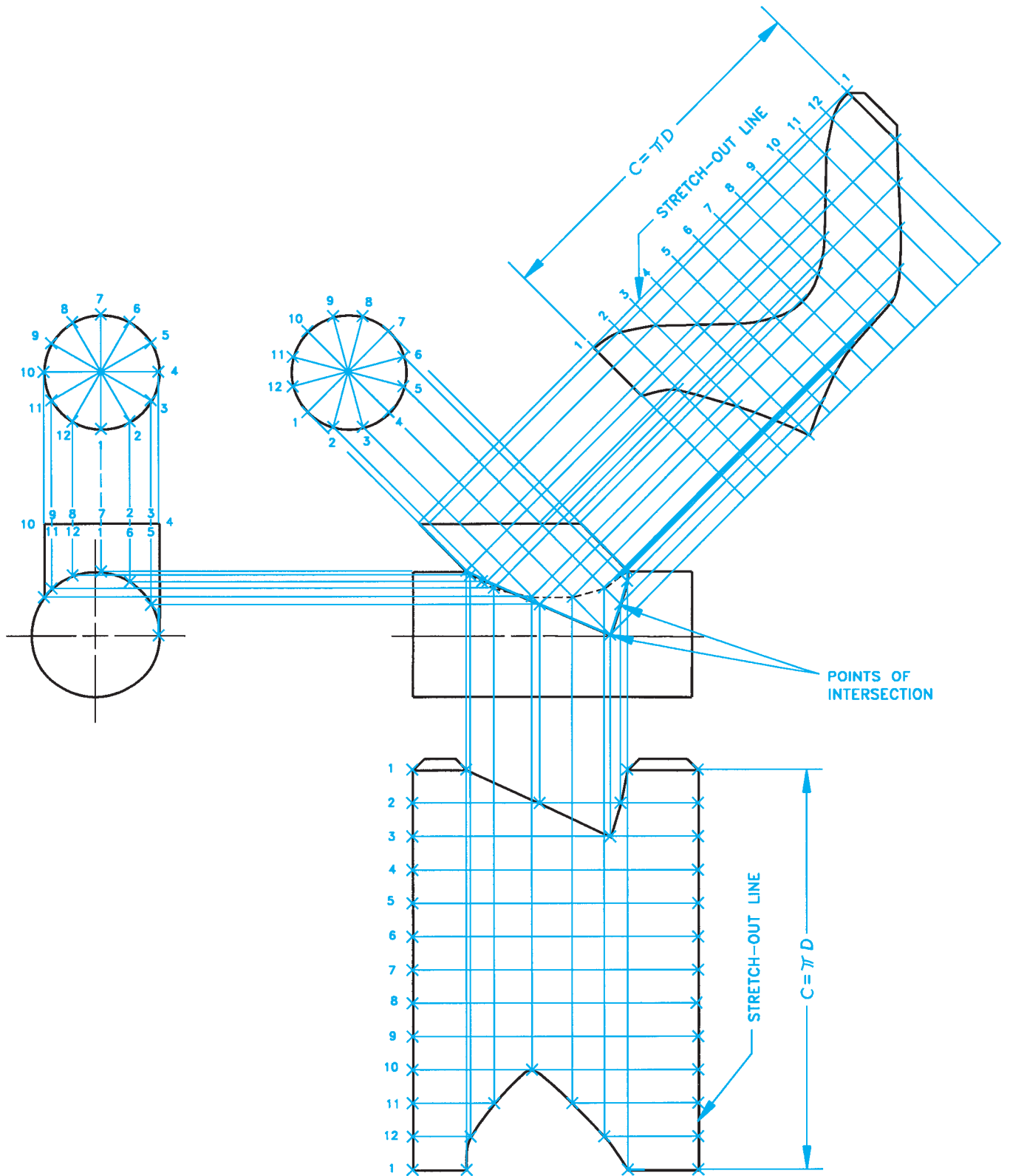
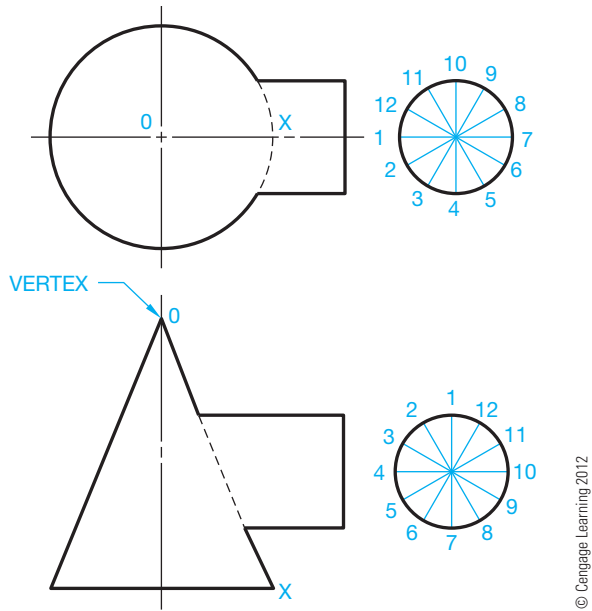


FIGURE 23.79 Offset intersecting cylinders and the pattern development for both cylinders. © Cengage Learning 2012

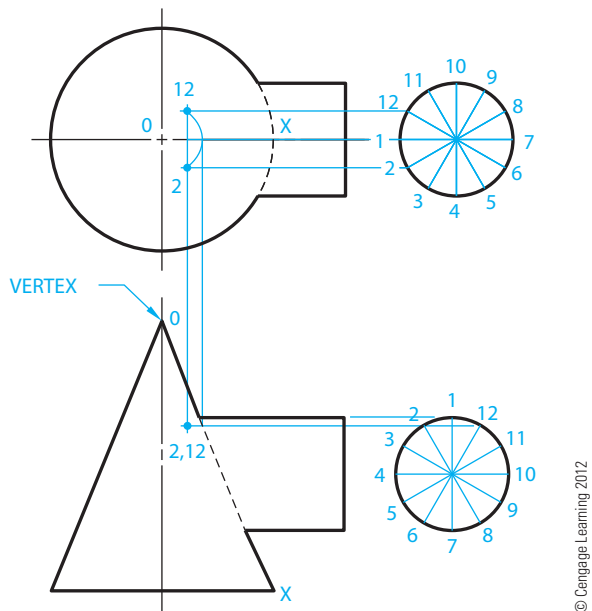


© Cengage Learning 2012

**FIGURE 23.80** Step 1: Setting up the intersection between a cone and a cylinder.

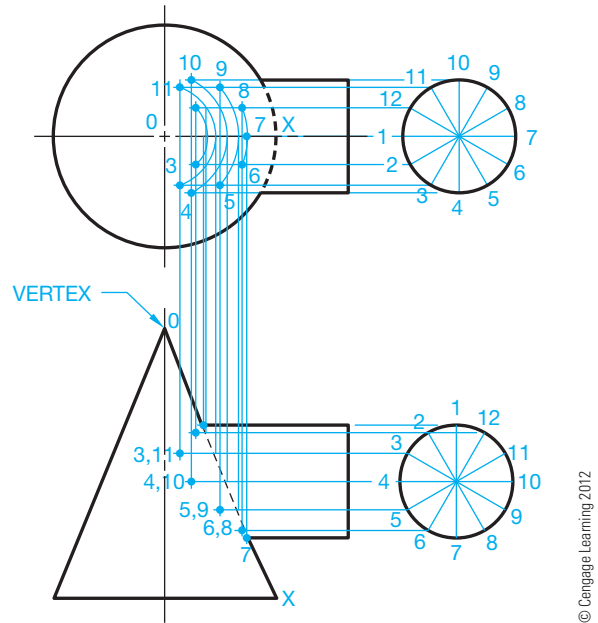
Draw an arc with a radius from 0 to this point of intersection. Project points 2 and 12 from the circle adjacent to the top view until they intersect this arc. These are the points of intersection of points 2 and 12 in the top view. Now project points 2 and 12 from the top view down until they intersect the projection line for 2 and 12 in the front view. This is the point of intersection for 2 and 12 in the front view (see Figure 23.81).

**STEP 4** Continue this process until each point has been located in each view (see Figure 23.82). Draw the line of intersection by connecting the points of intersection



© Cengage Learning 2012

**FIGURE 23.81** Steps 2 and 3: Determining the points of intersection between a cone and a cylinder.



© Cengage Learning 2012

**FIGURE 23.82** Step 4: Continuing the points of intersection between a cone and a cylinder.

with a curve. Be sure hidden lines are properly represented (see Figure 23.83).

**STEP 5** The pattern development for the cone is started by using the true-length side of the cone to draw the stretch-out line arc. The true-length side of the cone is element 0–X in the front view, which is also the edge view. Look at Figure 23.83 as you follow these steps:

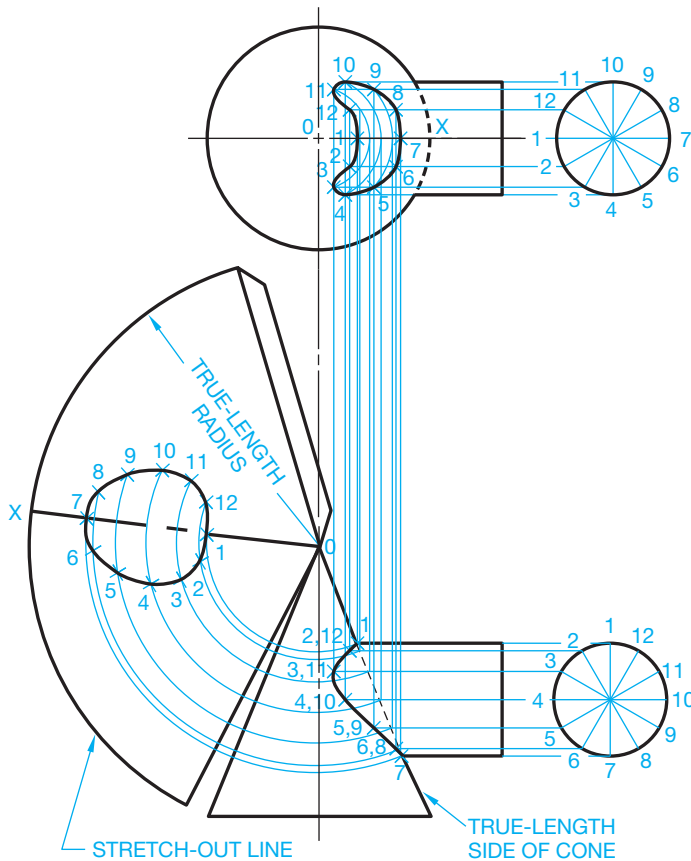
Lay out the circumference of the cone base along the stretch-out line, as you learned earlier in this chapter. Then establish element 0–X in the middle of the pattern. This line coincides with 0–X in the front and top views.

In the front view, project an arc with the center at the vertex (0) and the radius at point 1. Project this arc into the pattern where it intersects element 0–X. This is point 1 in the pattern.

In the front view, project an arc with the center at the vertex (0) and the radius at point 7. Project this arc into the pattern where it intersects element 0–X. This is point 7 in the pattern.

Repeat this by drawing an arc with the center at the vertex (0) and the radius at point each point of intersection in the front view. This results in a series of arcs projected into the pattern. There is an arc with radius 0–2 and 12, 0–3 and 11, 0–4 and 10, 0–5 and 9, and 0–6 and 8 (see Figure 23.83).

**STEP 6** In the top view, take measurements from the 0–X line at the point where the arcs passing through points 2 and 12 intersect. Measure from this intersection to point 2. The distance from 0–X to point 2 is the same as from 0–X to point 12 because this object is



**FIGURE 23.83** Steps 5 and 6: Connecting the points of intersection to establish the line of intersection between a cone and a cylinder and the pattern development for the cone. Follow previous cylinder development examples for developing the cylinder pattern. © Cengage Learning 2012

symmetrical. Take this measurement and transfer the distance to the pattern by measuring from the intersection of the 2,12 arc on the 0–X line, and place a point on each side of the 0–X line on this radius. The point on each side of the 0–X line on this radius is the location of points 2 and 12 in the pattern. Continue this process for each pair of points (3,11; 4,10; 5,9; and 6,8) until each point has been transferred into the pattern. Connect the points in the pattern to establish the cutout where the cylinder intersects the cone. Make a pattern development for the cylinder using the same procedure you used for other cylinder developments (see Figure 23.83).

### Undimensioned Drawings

**Undimensioned drawings** are engineering drawings that are created to an exact scale from which the designed part and associated tooling are produced directly by photographic processes or other processes. Drawings are generally drawn full scale, but they can be drawn at a larger or smaller scale as needed to define specific details. Drawings created at a scale other than full scale are returned to full scale before manufacturing. Undimensioned drawings provide the dimensional characteristics graphically rather than using traditional dimensioning practices. An example of a commonly used undimensioned drawing is for the sheet metal pattern where the given drawing without dimensions is used exactly as drawn to duplicate the flat pattern before bending. Review Chapter 19, *Precision Sheet Metal Drafting*, for expanded coverage on undimensioned drawings.

### SHEET METAL PATTERN DESIGN

Sheet metal patterns are drawn using CADD techniques that are similar to manual drafting. Many of the manual drafting geometric construction methods described in this chapter are effective for producing any type of sheet metal pattern. However, CADD tools such as layers, and specific commands including COPY, MOVE, OFFSET, ARRAY, TRIM, and DIVIDE greatly aid in the process of drawing any required sheet metal pattern.

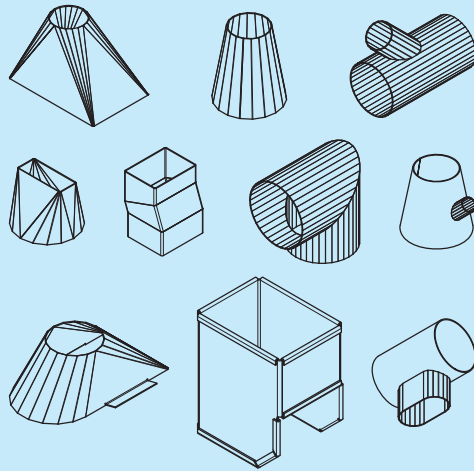
Specialized CADD software is also available that significantly automates the process of sheet metal pattern design and drafting. These programs can be used to generate nearly any sheet metal flat pattern layout needed, including the examples shown in Figure 23.84. Sheet metal patterns created using CADD software can be plotted full size, or the information can be transferred to computer numerical control burners, water jets, lasers, punch presses, or arc machines so the pattern can be cut or punched as necessary. The programs can automatically calculate sheet

layout for the best material conservation possible. Parametric design of sheet metal fabrication packages allows you to enter specific information about the design. For example, the variables H, Y, X, OX, and D are shown on the transition piece in Figure 23.85. After you input the variable information, the program automatically draws the flat pattern on the screen and provides a print file of all the development information for your reference as shown in Figure 23.86.

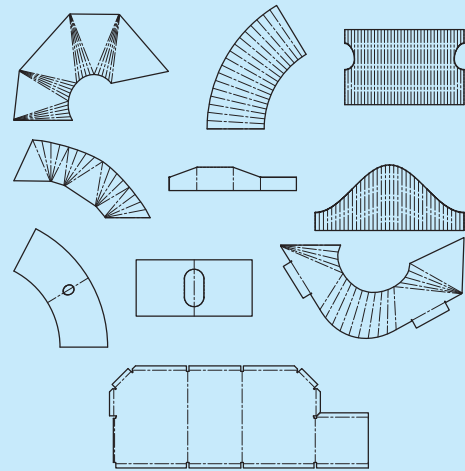
### DOWNLOAD BUILDING PRODUCT MODELS, DRAWINGS, AND SPECIFICATIONS

The Autodesk Seek free Web service allows architects, engineers, and other design professionals to quickly discover, preview, and download branded and generic BIM files, models, drawings, and product specifications directly into active design sessions in Autodesk Revit® or AutoCAD software. For building product manufacturers,

(Continued)

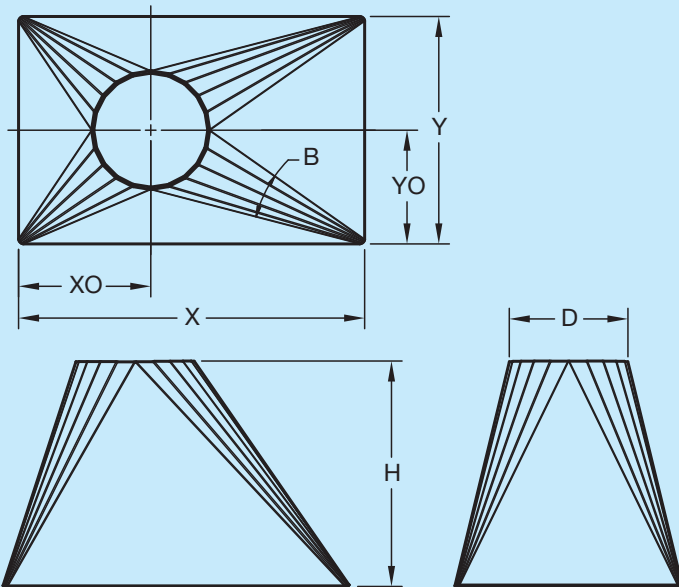


SAMPLE SHAPES



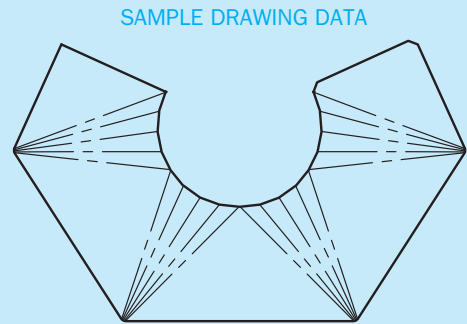
SAMPLE FLAT PATTERNS

FIGURE 23.84 A variety of sheet metal shapes and patterns can be easily drawn on a CADD system.



RECTANGLE TO ROUND		
ONE OFFSET - NO ANGLES		
RECTANGLE TO LENGTH X DIRECTION	X	16.375
RECTANGLE TO LENGTH Y DIRECTION	Y	10.750
HEIGHT	H	10.635
ROUND DIAMETER	D	5.600
NUMBER OF BREAKS PER CORNER	B	6
OFFSET IN X DIRECTION	OX	6.237
OFFSET IN Y DIRECTION	OY	5.375
OFFSET MAY BE IN X OR Y DIRECTION FROM LOWER LEFT CORNER OF THE RECTANGLE		

FIGURE 23.85 Parametric CADD programs are available to design duct fittings by giving variable information and having the pattern development quickly created. Any changes made to the pattern or the model automatically affect the same changes in the other.



X MATERIAL SIZE = 21.137  
 Y MATERIAL SIZE = 14.056  
 SQ. IN. = 297.101

SAMPLE PRINTER LISTING

SQUARE/RECTANGLE TO ROUND LISTING

HALF = 1  
 MATERIAL X = 21.137  
 MATERIAL Y = 14.056

BREAKLINES PER CORNER = 5  
 DIAMETER OF ROUND = 5.375  
 HEIGHT OF TRANSITION = 5.375  
 LENGTH OF FIRST LINE (X) = 12.125  
 LENGTH OF SECOND LINE (Y) = 10.5  
 X COORDINATE OF ROUND CENTER = 8.25  
 Y COORDINATE OF ROUND CENTER = 5.25  
 1ST ENDPOINT: X = 0.000 Y = 3.234  
 1ST BASEPOINT: X = 4.136 Y = 0.000  
 2ND BASEPOINT: X = 16.261 Y = 0.000  
 2ND ENDPOINT: X = 21.137 Y = 1.944

POINTS ON ROUND TO FIRST BASEPOINT:

X = 8.463 Y = 14.056  
 X = 9.341 Y = 13.483  
 X = 10.311 Y = 13.085  
 X = 11.338 Y = 12.874  
 X = 12.386 Y = 12.821

POINTS ON ROUND TO SECOND BASEPOINT:

X = 12.386 Y = 12.821  
 X = 13.433 Y = 12.867  
 X = 14.469 Y = 13.027  
 X = 15.481 Y = 13.302  
 X = 16.465 Y = 13.665

FIGURE 23.86 This is an example of the flat pattern drawing and flat pattern development information provided by the CADD system.

Courtesy Engineering Drafting & Design, Inc.

Courtesy Engineering Drafting & Design, Inc.

Courtesy Engineering Drafting & Design, Inc.

Autodesk Seek offers a unique way to connect with the professional designers who are ultimately responsible for specifying and recommending their products for purchase. Autodesk Seek provides the following features:

- **Manufacturer-supplied product information:** Access building information models, drawings, and product specifications for more than 35,000 commercial and residential building products from nearly 1000 manufacturers.
- **Powerful parametric search technology:** Search by key attributes, including dimensions, materials, performance, sustainability, or manufacturer name using industry-standard classifications.
- **Preview and explore models before downloading:** View, rotate, zoom, and slice product models and then download the accurate files directly into your design session. For Revit models, preview the family parameters and associated type catalogs before downloading.
- **Multiple formats:** Select the formats that work for you, such as Revit, DWG™, DGN, and SKP files; Microsoft® Word documents; three-part specifications; and PDFs.

- **Share designs:** You can share designs with peers by uploading them directly from your AutoCAD files to the Autodesk Seek User Uploads. Easily access the Share with Autodesk Seek button from the Output panel of the ribbon tab. You can choose to share the current drawing or select a block definition within the drawing. Thumbnails, title, and metadata are automatically extracted and indexed. Shared designs can be searched and downloaded by anyone.

When using Autodesk Seek, your default browser is launched and search results are shown. Figure 23.87 shows the browser open with a sample of HVAC search results displayed. A complete set of electrical applications are provided in the actual search. Move your cursor over the thumbnail image of the item to view an enlarged image and description of the product. To the right of each electrical item are viewing options such as DWG, RFA, DXF, PDF, and Word files.

Similar products are available from other CADD software developers and from product manufacturers.

The screenshot shows the Autodesk Seek interface. At the top, there's a search bar with 'hvac' entered. Below the search bar, there are filter options for Content Source, Manufacturers, Product Libraries, File Type, Product Attributes, and External Catalogs. The main area displays search results for 'Product | Manufacturer'. The results are sorted by Relevance and show 21-40 of 42 entries. Each result includes a thumbnail image of the HVAC unit, the product name, the manufacturer (Mitsubishi Electric), and download options for RFA, DWF, and ZIP files. The results list various HVAC units from Mitsubishi Electric, including ceiling ducted, suspended, floor unit, indoor one way cassette, floor unit, indoor unit wall mounted, and lossnay units.

**FIGURE 23.87** The browser open with a sample of HVAC search results displayed using Autodesk Seek.

# PROFESSIONAL PERSPECTIVE

## HVAC

This chapter has covered the engineering drafting HVAC and related sheet metal fabrication. If you are a drafter for a mechanical (HVAC) engineer, you are likely to draw HVAC plans, details, and schedules. The drawings from your office are sent to a sheet metal fabricator where the duct components can be built and delivered to the construction site. Your colleague in the fabrication industry takes the drawing from the mechanical engineer's office and converts the duct shapes to flat pattern layouts for fabrication. In many cases, HVAC fabrication drawings do not dimensions. The sheet metal pattern is used to fabricate the duct shape.

If you enter the HVAC industry, you should become familiar with HVAC vendors' catalogs and manuals and duct design engineering information available from mechanical suppliers such as Trane, Lennox, Apec, and Elite.

## PATTERN DEVELOPMENT

The following is provided by Brad Dotson of B&D Consulting.

There is great value in learning about creating pattern developments as a study of carrying projection lines between views and for developing visualization skills. A drafter uses pattern development for many different applications. Patterns are commonly created by drafters for items such as convector covers, plenum panels with penetrations, and some architectural sheet metal shapes, but never for sheet metal fittings such as elbows, tees, and transitions. However, this is valuable knowledge to have, as it gives you an understanding of how the parts are assembled to form a fitting. But the actual layout and pattern development of basic fittings by a drafter has little or no application in the HVAC industry. Creating pattern layouts is a

requirement for people in a sheet metal apprentice program. Almost all shops have gone to computerized plasma cutting systems that have a wide variety of fittings from which to choose. Fittings that cannot be input into the cutting system hardware are hand listed on cut sheets and given to the shop. Most, if not all, fabrication shops employ an experienced layout person. When a fitting is encountered that is not available in the standard fitting library, the layout person creates the pattern directly from a sheet metal blank. This only occurs when a very complicated fitting is required. A good example might be a continuous slope drop cheek square throat elbow. These layout persons have seen every type of fitting and can lay them all out, so it is unlikely in the extreme that a drafter would ever have to lay out a fitting and forward the pattern to the shop. Most of the cutting systems have the ability to cut patterns based on a **dxg file**. AutoCAD DXF (drawing interchange format or drawing exchange format) is a CAD data file format developed by Autodesk for allowing data to work together between AutoCAD and other programs. If there is a shape that you want to cut out, then you can draw the shape in AutoCAD, create a dxg file, and input the dxg file into the computerized shop plasma cutting system.

These plasma systems are widely used, even by smaller shops. When you input a list of fittings into the plasma system, it sorts the fittings by gage, analyzes the individual shapes within that gage, **nests** the pieces onto the **sheet metal blanks** to minimize scrap, and then cuts the fitting blanks out. *Nest* means to organize the patterns on sheet metal sheets in a manner that reduces waste. Sheet metal blanks are sheets of sheet metal. The computer system also prints labels out for each blank in the order that it will be cut so that the worker running the table can put the labels on as the system cuts out the pieces.

## AIR-DUCT SIZING FORMULAS

Use the following formula to size a duct for the proper CFM:

$$\text{CFM} = \text{Area} \times \text{FPM}$$

Example: 12 × 18 duct at 850 FPM.

$$12 \text{ IN} = 1 \text{ ft.} \quad 12 \times 18 = 1 \text{ ft.} \times 1.5 \text{ ft.} = 1.5 \text{ sq. ft.}$$

$$1.5 \text{ sq. ft.} \times 850 \text{ FPM} = 1275 \text{ CFM}$$

Use the following formula to change the shape of a duct from round to square:

$$\text{Area of a circle} = \pi R^2$$

$$\text{Area} / \text{length} = \text{width}$$

Example: Convert a 24" round duct to a 12" deep square or rectangular duct.

$$\begin{aligned} \text{Area of a 24 IN diameter circle} &= \pi 12^2 \\ &= 452 \text{ sq. IN (rounded)} \end{aligned}$$

$$492 / 12 = 41 \quad \text{A 24" round duct} = 12 \times 38 \text{ rectangular duct.}$$

Use the following formula to change the shape of a duct from square to round:

$$2(\text{square root} [\text{area}/\pi]) = \text{diameter}$$

Example: Convert a 12 × 24 rectangular duct to an equivalent round duct.

$$\text{Area} = 12 \times 24 = 288 \text{ sq. IN}$$

$$\begin{aligned} 2(\text{square root} [288/3.14159]) &= 2(\text{square root } 91.67) \\ &= 2(9.57) = 19.14 \end{aligned}$$

A 12 × 24 square duct = 20" round duct. Round 19.14 to 20.

## WEB SITE RESEARCH

The following Web sites can provide you additional information for research or further study into topics covered in this chapter.

Address	Company, Product, or Service
www.alcoa.com	Alcoa.
www.asme.org	Find information and publications related to the American Society of Mechanical Engineers, including ASME Y14.5-2009, <i>Dimensioning and Tolerancing</i> , and ASME Y14.31-2008, <i>Undimensioned Drawings</i> .
www.ansi.org	The American National Standards Institute. Information about national and international drafting standards, including ASME Y14.5-2009, <i>Dimensioning and Tolerancing</i> .
www.adda.org	American Design Drafting Association, <i>Drafting Reference Guide</i> .
www.industrialpress.com	Information about the <i>Machinery's Handbook</i> . This is a valuable resource for manufacturing standards, sizes, tolerances, fits, materials, and anything else you can think of for design and drafting.
www.industrialpress.com	Online trigonometry tables.
www.globalspec.com	The Engineering Web makes it faster and easier for you to research topics, products, and services by limiting your search to technical and engineering-related Web sites.
www.g-w.com	Select "Technical and Trades Technology," followed by "CAD/Animation/Drafting," and look for the latest, or your desired, edition of <i>AutoCAD and Its Applications, Basic</i> . This provides in-depth coverage on the use of AutoCAD to create dimensions based on ASME and other accepted standards.
www.amazon.com	Search Books for <i>AutoCAD and Its Applications</i> .
www.quickpen.com	CADD applications using Quickpen DD 3-D.
www.shopdata.com	CADD applications using Quickduct.
www.cadduct.com	CADD applications using CAD-Duct.
www.sheetmetaldetailing.com	Brad Dotson, B & D Consulting.

## Chapter 23

### Chapter 23 Heating, Ventilating, and Air-Conditioning (HVAC), and Pattern Development Test



To access the Chapter 23 test, go to the Student CD, select **Chapter Tests and Problems**, and then **Chapter 23**. Answer the questions

with short, complete statements, sketches, or drawings as needed. Confirm the preferred submittal process with your instructor.





**Drafting Templates**

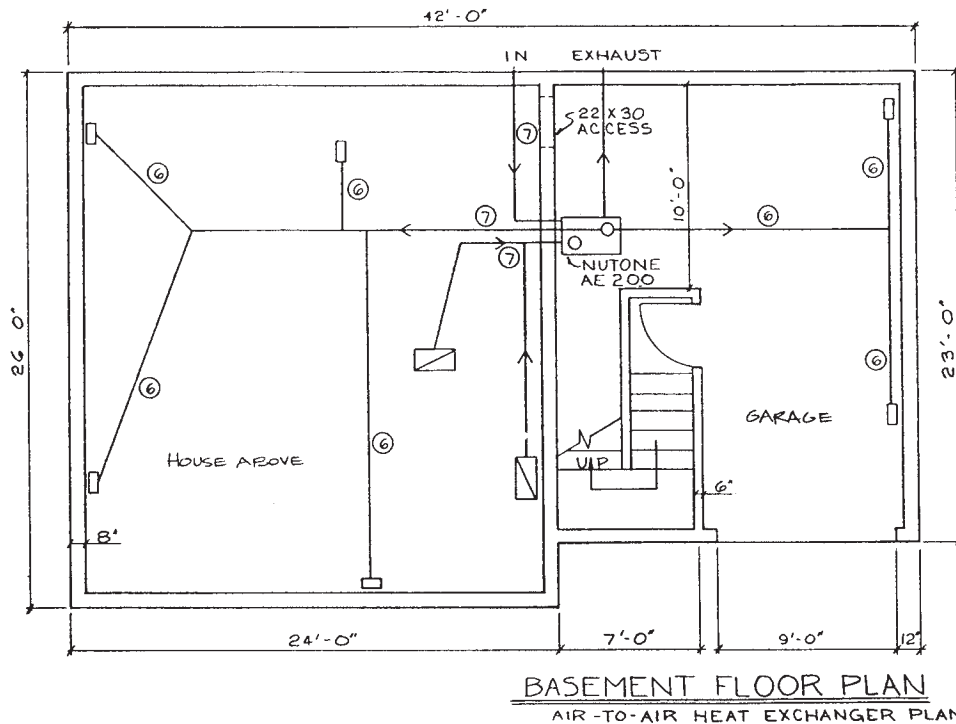
To access CADD template files with predefined drafting settings, go to the Student CD, select **Drafting Templates**, and then select the appropriate template file.

**PROBLEM 23.2 Residential air-to-air heat exchanger plan**

Given: Residential air-to-air heat exchanger ducting engineering sketch of a basement floor plan. Do the follow-

ing on appropriately sized sheets with a border and an architectural-style title block, unless otherwise specified by your instructor. One B- or C-size sheet is recommended.

1. Make a formal single-line air-to-air heat exchanger floor plan layout at a 1/4" = 1'-0" scale.
2. Approximate the location of undimensioned items such as doors.
3. Place drawing features on unique layers using the AIA layer standard names where possible. Use thin lines for the floor plan layout and use thick lines for the air-to-air heat exchanger equipment and duct runs.



© Cengage Learning 2012

**PROBLEM 23.3 Commercial HVAC plan**

You are given the following:

1. An HVAC floor plan engineering layout is at approximately 1/16" = 1'-0". The engineer's layout is rough, so round off dimensions to the nearest convenient units at 6" intervals. For example, if the dimension you scale reads 24 ft. 3 IN, then round off to 24 ft. 0 IN. The floor plan does not require dimensioning, so the representation is more important than the specific dimensions.
2. Related schedules.
3. Engineer's sketch for exhaust hood.

SCHEDULES					
CEILING OUTLET SCHEDULE					
Symbol	Size	CFM	Damper Type	Panel Size	
C-10	9 9	240	Key operated	12	12
C-11	8 8	185	Key operated	12	12
C-12	6 6	40	Key operated	12	12
C-13	6 6	45	Key operated	12	12
C-14	6 18	300	Fire damper	24	24

SUPPLY GRILL SCHEDULE					
Symbol	Size	CFM	Location	Damper Type	
S-1	20 8	450	High wall	Key operation	
S-2	12 12	450	High wall	External operation	

EXHAUST GRILL SCHEDULE				
Symbol	Size	CFM	Location	Damper Type
E-5	18 X 24	1000	Low wall	No damper

ROOF EXHAUST FAN SCHEDULE			
Symbol	Area Served	CFM	Fan Specifications
REF-1	Solvent Tank	900	1/4 HP, 12 IN nonspark wheel, 1050 max. outlet velocity

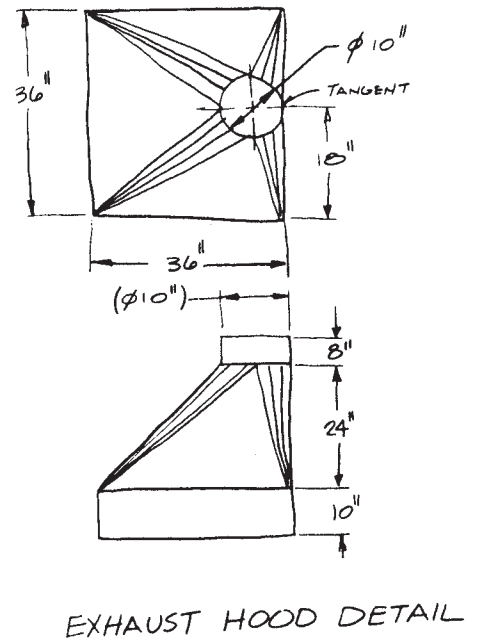
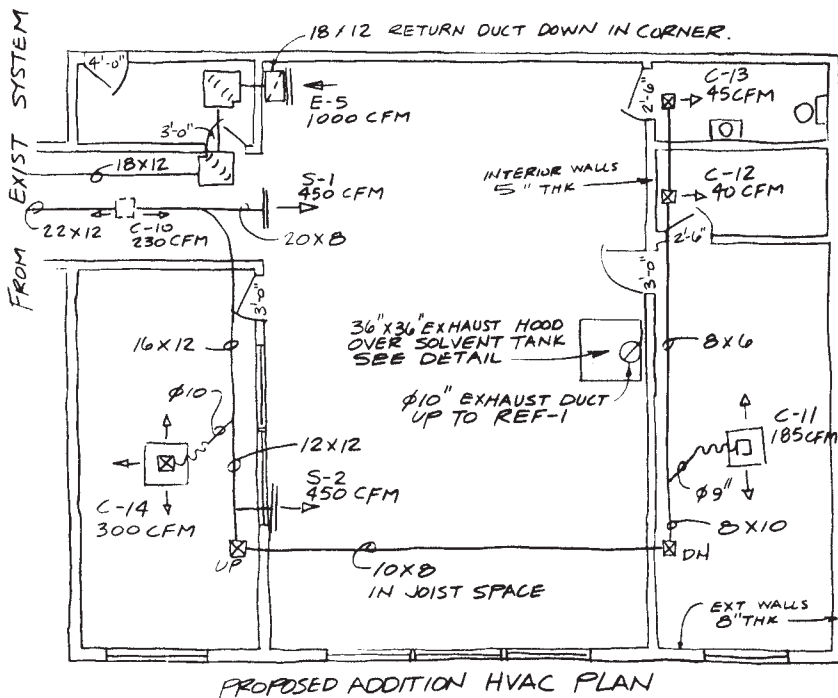
Do the following on appropriately sized sheets with borders and architectural-style title blocks, unless otherwise specified by your instructor. A D-size sheet is recommended. All required items will fit on one sheet with careful planning.

1. Make a formal double-line HVAC floor plan layout at a  $1/4" = 1'-0"$  scale. (Note: You measured the given engineer's sketch at  $1/16" = 1'-0"$ .) Now convert the established dimensions to a formal drawing at  $1/4" = 1'-0"$ . Approximate the location of the HVAC duct runs and equipment in proportion to the presentation on

- the sketch. Assume that the given single-line sketch represents the centerline of the ducts.
2. Prepare correlated schedules in the space available. Set up the schedules in a manner similar to the examples in Figure 23.23, page 1038, for layout.
3. Make a detail drawing of the exhaust hood either scaled or unscaled. Make the detail large enough to clearly show the features. Refer to Figure 23.20, pages 1035–1036, for an example of a detail drawing.
4. Approximate the location of doors, windows, and fixtures.
5. Place drawing features on unique layers using the AIA layer standard names where possible. Draw the floor plan layout using thin lines and the HVAC components with thick lines for contrast.



**NOTE:** Do not include notes and dimensions for wall thickness, door sizes, and tangent. Top view of exhaust hood detail is drawn as a transition piece, similar to Figure 23.68.



© Cengage Learning 2012

Part 2: Problems 23.4 and 23.5



To access the Chapter 23 problems, go to the Student CD, select **Chapter Tests and Problems** and **Chapter 23**, and then open

the problem of your choice or as assigned by your instructor. Solve the problems using the instructions provided on the CD, unless otherwise specified by your instructor.

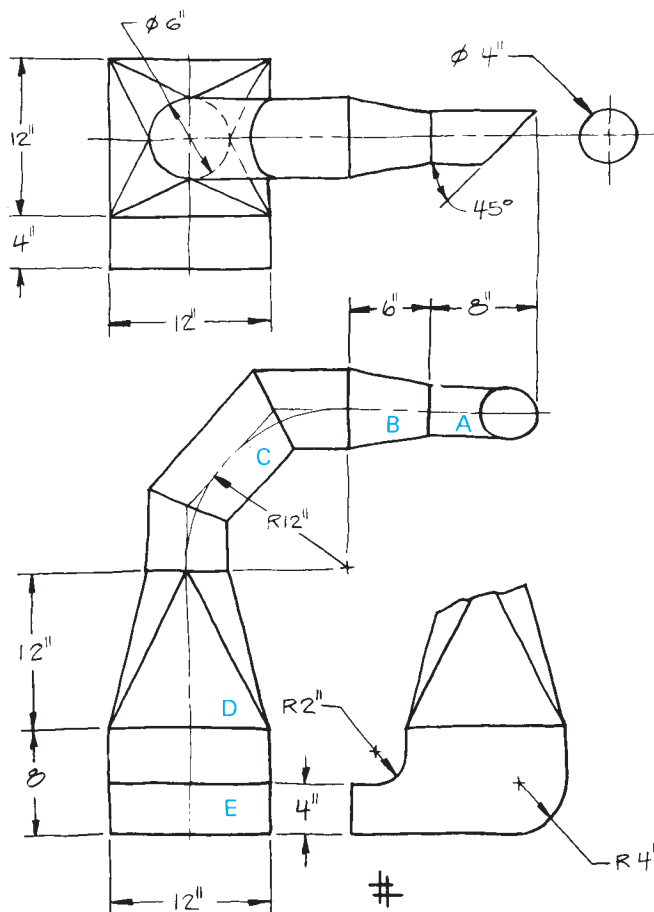
Part 3: Problems 23.6 Through 23.14

PROBLEM 23.6 Exhaust duct system (in.)

Given: The engineer's sketch and specifications for an exhaust duct system. The sketch displays the top, front, and partial left side views of an exhaust duct system that could be found in any commercial solid-fuel exhaust. The exhaust pickup is rectangular in shape, and the discharge throat is cylindrical. The directional path of the system is often obstructed and closely confined for reasons of design and operation of the system.

Do the following on an appropriately sized sheet or sheets with border and architectural-style title blocks:

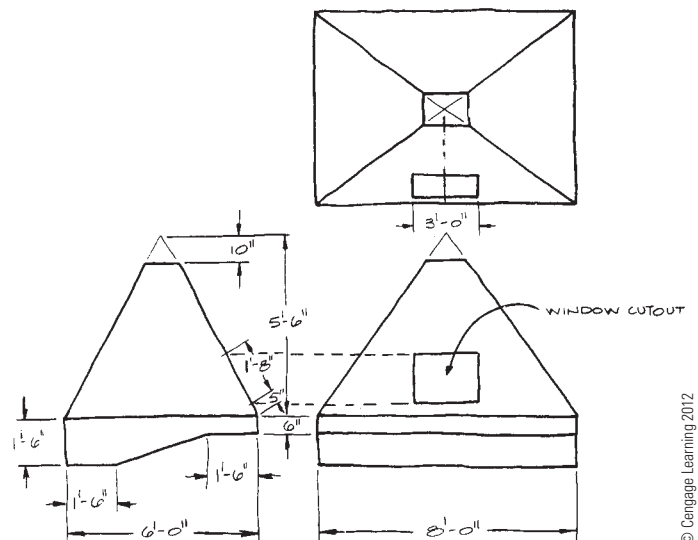
1. Make a pattern development for each of the five exhaust duct components. There are five individual pattern development drawings:
  - a. Truncated cylinder.
  - b. Truncated cone.
  - c. Three-piece elbow.
  - d. Square-to-round transition piece.
  - e. Rectangular transitional elbow.
2. Use full scale unless otherwise specified by your instructor. Use a 3/8 IN single-lap seam on individual parts and between adjacent parts.
3. Show all layout and construction. Do not turn off or freeze your construction layer unless otherwise specified by your instructor.



PROBLEM 23.7 Welding booth hood (in.)

Given: The engineer's sketch of a fabrication shop's welding booth hood. Do the following on an appropriately sized sheet or sheets with border and architectural-style title blocks:

1. Make a pattern development drawing of the pyramid-shaped hood and the shroud base at full scale, unless otherwise specified by your instructor.
2. Provide the cutout for the window to be added later. Be careful to find the true location and true size and shape of the cutout in the pattern.
3. No seam material allowance is required because the seams will be welded.
4. Show all layout and construction on a construction layer.



PROBLEM 23.8 Exhaust hood (in.)

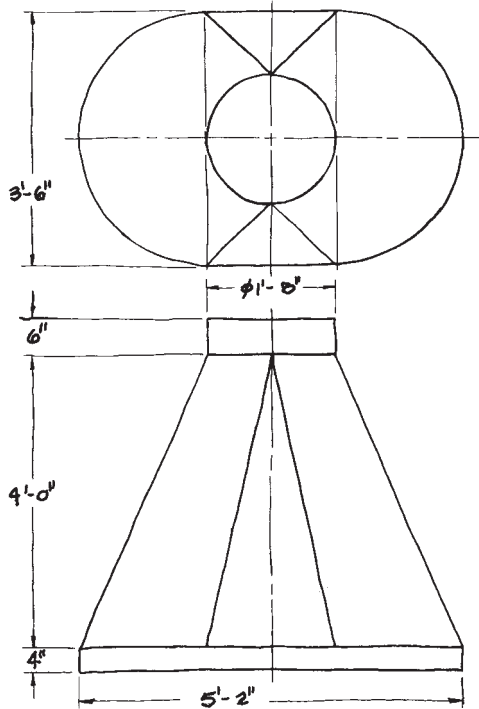
Given: The exhaust hood detail from Problem 23.3. Do the following on an appropriately sized sheet or sheets with border and architectural-style title blocks:

1. Make a pattern development on appropriately sized layout for the transition piece, the top collar, and the base collar.
2. Use full scale, unless otherwise specified by your instructor.
3. Provide a 1 IN single-lap seam for each part and between adjacent parts.
4. Show all layout and construction using a construction layer.

**PROBLEM 23.9 Chemistry laboratory hood (in.)**

Given: The engineer's rough sketch of the chemistry laboratory hood. Do the following on an appropriately sized sheet or sheets with a border and architectural-style title blocks:

1. Make a pattern development drawing of the chemistry laboratory hood, including the top and bottom collars.
2. Use full scale, unless otherwise specified by your instructor.
3. No seams required.
4. Show all layout and construction using a construction layer.

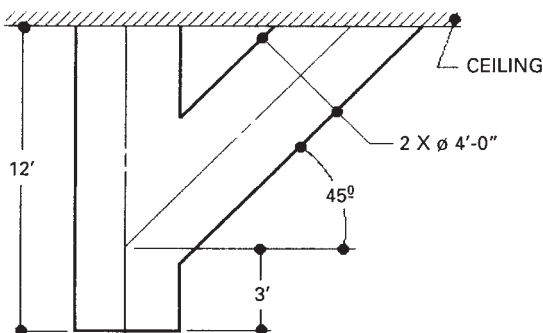


© Cengage Learning 2012

**PROBLEM 23.10 Cylindrical duct intersection (in.)**

Given: The engineer's computer sketch of intersecting cylindrical ducts. Do the following on an appropriately sized sheet or sheets with a border and architectural-style title blocks:

1. Use full scale, unless otherwise specified by your instructor.
2. Find the intersection between the cylindrical ducts.
3. Make a pattern development for each cylinder.
4. Use a 1 IN (scale) double-lap seam.
5. Show all layout and construction using a construction layer.

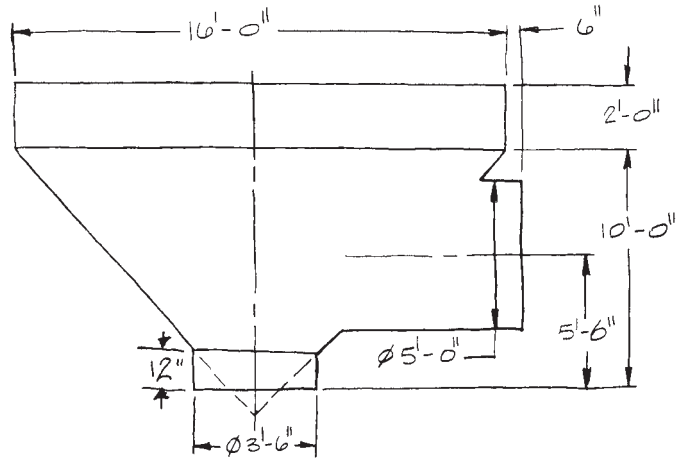


© Cengage Learning 2012

**PROBLEM 23.11 Grain hopper (in.)**

Given: The engineer's sketch of the grain hopper. Do the following on an appropriately sized sheet or sheets with a border and architectural-style title blocks:

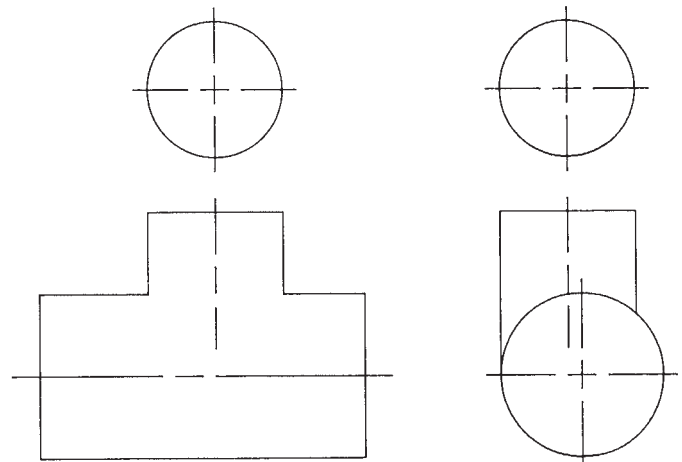
1. Use full scale, unless otherwise specified by your instructor.
2. Determine the line of intersection between the cylinder and the cone in both views.
3. Make the resulting pattern development of the cone and side intersecting cylinder.
4. No seam material allowance required.
5. Show all layout and construction using a construction layer.



© Cengage Learning 2012

**PROBLEM 23.12 Intersection**

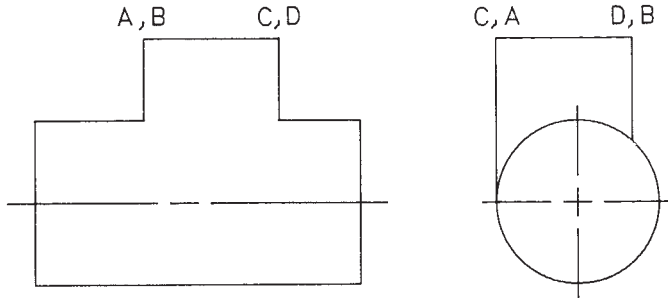
Given the following drawing, use a 1/4" = 1'-0" scale to measure the given drawing. Make your drawing full scale using the measurements, unless otherwise specified by your instructor. Determine the line of intersection between the parts. Show all construction using a construction layer.



© Cengage Learning 2012

**PROBLEM 23.13 Intersection**

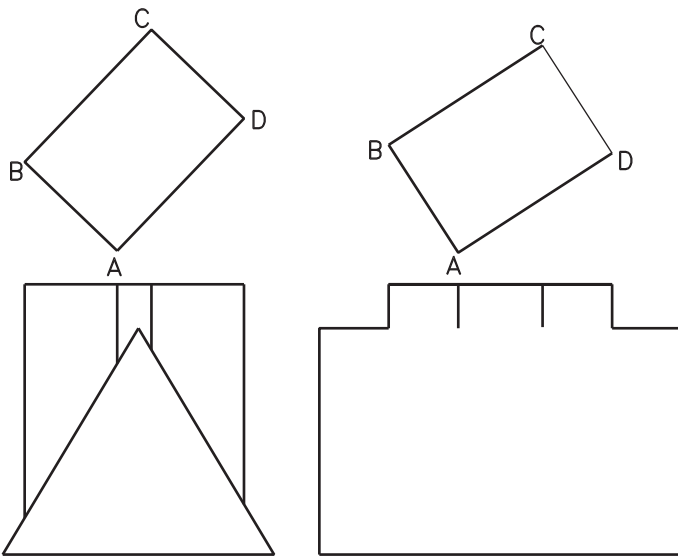
Given the following drawing, use a 1/4" = 1'-0" scale to measure the given drawing. Make your drawing full scale using the measurements, unless otherwise specified by your instructor. Determine the line of intersection between the parts. Show all construction using a construction layer.



© Cengage Learning 2012

**PROBLEM 23.14 Intersection**


Given the following drawing, use a 1/4" = 1'-0" scale to measure the given drawing. Make your drawing full scale using the measurements, unless otherwise specified by your instructor. Determine the line of intersection between the parts. Show all construction using a construction layer.



© Cengage Learning 2012


**Complete Sequence of HVAC Drawings**

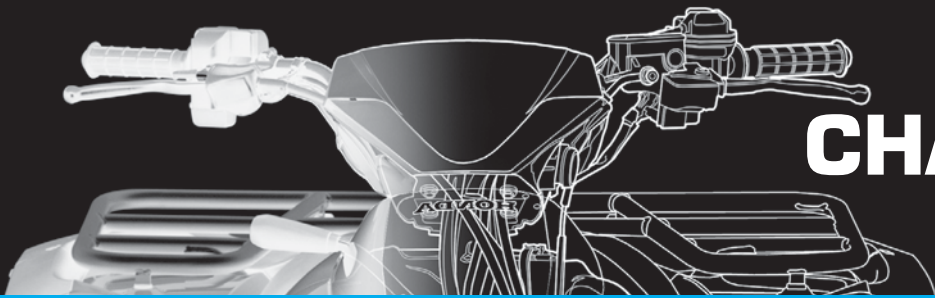
**Part 4: Problem 23.15**

 To access the Chapter 23 problems, go to the Student CD, select **Chapter Tests and Problems** and **Chapter 23**, and then open the problem of your choice or as assigned by your instructor. Solve the problems using the instructions provided on the CD, unless otherwise specified by your instructor.

**Math Problems**

**Part 5: Problems 23.16 Through 23.20**

 To access the Chapter 23 problems, go to the Student CD, select **Chapter Tests and Problems** and **Chapter 23**, and then open the math problem of your choice or as assigned by your instructor. Solve the problems using the instructions provided on the CD, unless otherwise specified by your instructor.



# CHAPTER 24

## Civil Drafting

### LEARNING OBJECTIVES

After completing this chapter, you will:

- Calculate unknown values of bearings, slopes, and curve dimensions.
- Draw transit lines for roadway layouts.
- Reduce survey information from field notes.
- Prepare site plans and profiles for cut and fill work.
- Draw plans and profiles from survey information.

## THE ENGINEERING DESIGN APPLICATION

A new roadway, Valerian Lane, is going to be built from Erika Street to Quincey Avenue (see Figure 24.1). The information in the table in Figure 24.2 is given to you by the designer and survey department.

How would you go about executing this project? First, finish the required mathematical calculations for the chart

and then lay out Valerian Lane. To complete the unknown portions of the chart and draw the new roadway, you must understand the concepts of survey and civil drafting. This represents typical work done by a civil drafter and is covered in this chapter.

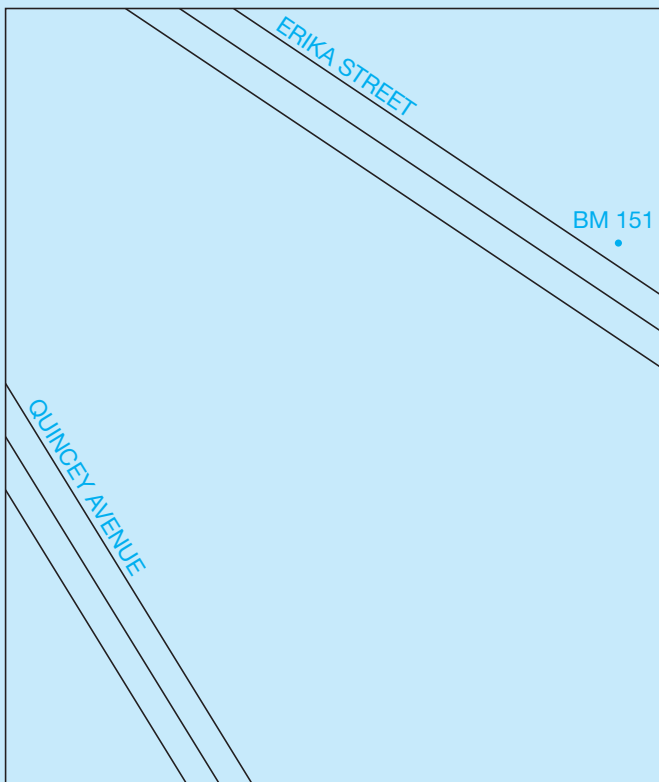


FIGURE 24.1 Example of a roadway layout. © Cengage Learning 2012

STATION	TRANSIT LINE FOR VALERIAN LANE FROM ERIKA STREET (BEARING $N56^{\circ}16'W$ ) TO QUINCEY AVENUE (BEARING $N31^{\circ}24'W$ )
0 + 00 Begin Project	245.78' $N67^{\circ}37'W$ from BM 151 to centerline of Erika Street. Then 132.00' $33^{\circ}44'W$ to P.C.
STA 1 + 32	P.C. to the left Curve Data $R = 200'$ $\Delta = 47^{\circ}23'$ $L = ?$ $D = ?$
STA ?	P.R.C. Curve Data $R = 170'$ $\Delta = 72^{\circ}15'$ $L = ?$ $D = ?$
STA ?	P.T.
STA ? End Project	$S58^{\circ}36'W$ from STA ? to centerline of Quincey Avenue

FIGURE 24.2 Survey information. © Cengage Learning 2012

## INTRODUCTION TO SURVEY: DIRECTION

Think of Earth as having imaginary lines that partition it into sections for the purpose of exactly pinpointing the area to be described. These lines divide Earth horizontally and vertically into lines of **latitude** (sometimes referred to as *parallels*) and lines of **longitude** (sometimes referred to as *meridians*). These two sets of grid lines are called the **graticule** of Earth. Parallels and meridians are shown in Figure 24.3.

Lines of latitude do not intersect. They are approximately the same distance apart (about 69 statute miles). The longest line of latitude is around Earth at the equator, and the shortest lines are around the north and south poles. These parallels are numbered from 0 degrees at the equator to 90 degrees at each pole as shown in Figure 24.4. When describing a particular point on Earth, a numbered latitude coordinate is given with N or S to describe north or south of the equator.

Lines of longitude are all about the same length and meet at both poles. They divide Earth into 360 degrees. Each line of longitude is numbered as shown in Figure 24.5. The zero line of longitude is the **prime meridian**, and the other lines, including those between the ones shown here, are **local meridians**. The most generally accepted prime meridian runs through

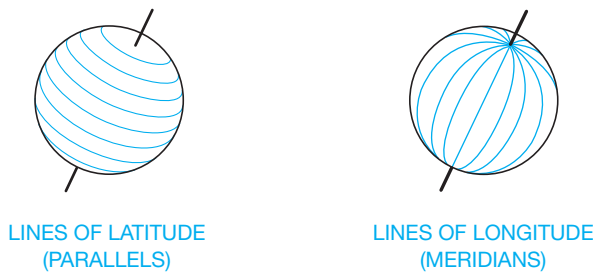


FIGURE 24.3 Latitude and longitude. © Cengage Learning 2012

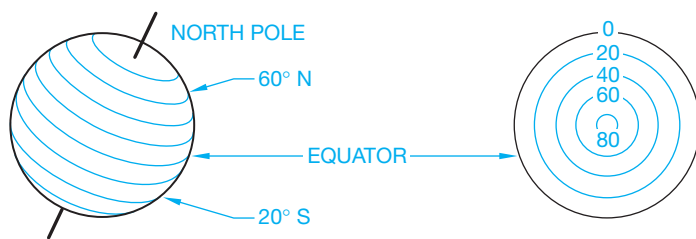


FIGURE 24.4 Latitude coordinates. © Cengage Learning 2012

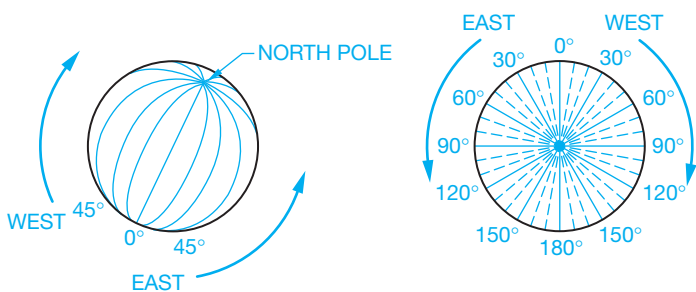


FIGURE 24.5 Longitude coordinates. © Cengage Learning 2012

City	Latitude	Longitude
Kolkata, West Bengal, India	22.30 N	88.20 E
Greenwich, England	51.29 N	00
Los Angeles, California, USA	34.00 N	118.15 W
Madrid, Spain	40.25 N	3.43 W
Paris, France	48.52 N	2.20 E
Rio de Janeiro, Brazil	22.53 S	43.17 W
Sydney, Queensland, Australia	16.40 S	139.45 E
Tokyo, Japan	35.40 N	139.45 E
Vancouver, British Columbia, Canada	49.13 N	123.06 W

FIGURE 24.6 Cities and their coordinates. © Cengage Learning 2012

Greenwich, England, although some countries in a spirit of nationalism have defined the prime meridian (0 degrees longitude) as going through their major city. Note that even though the length of the lines of longitude remains constant, the area between them decreases the closer they get to the poles.

Each latitude degree and longitude degree is further divided into 60 equal sections called *minutes*, and each minute is divided into 60 equal sections called *seconds*. The symbol for minute is (*'*), and the symbol for second is (*"*). Therefore, a latitude of 29 degrees, 15 minutes, 47 seconds to the north of the equator would be shown as 29°15'47"N. A longitude of 125 degrees, 12 minutes, 53 seconds to the east of the prime meridian (at Greenwich, England) is shown as 125°12'53"E. Figure 24.6 shows some cities and their latitude and longitude coordinates.

### Direction

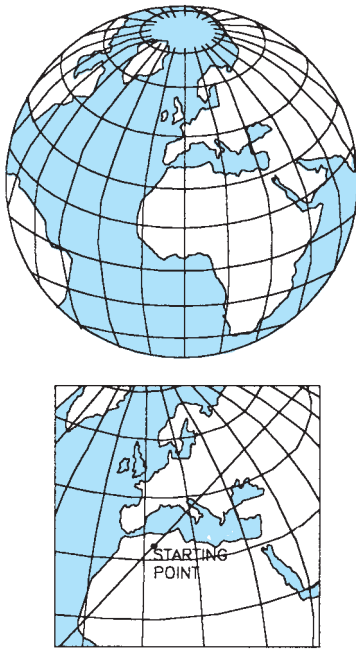
The direction around Earth from a given point in relation to the latitude and longitude coordinates describes a **great circle**. There are an infinite number of great circles. The great circle in Figure 24.7 has a starting point in northern Africa. From this one point, which has coordinates of its own, describe the direction the great circle goes. To do this, use the true azimuth or bearing.

To understand both of these processes, imagine Earth as having an X-axis through the equator and a Y-axis through the poles. Draw smaller portions of Earth on this square grid or plane coordinate system as shown in Figure 24.8.

### True Azimuth

The measurement that indicates the direction of a line (in this case, the great circle) is the horizontal angle to the right of the line from north. In other words, the **azimuth** is the angle (going clockwise) between the meridian at the starting point and the great circle. This means that the direction of that particular line is relative to the meridian at a particular point. These horizontal angles are described as the azimuth readings and can measure from 0° to 360°. In Figure 24.9, the azimuth of line AB is 35°, and the azimuth of line AC is 110°. All azimuth readings are





© Cengage Learning 2012

FIGURE 24.7 Great circle.

from a meridian, yet depending on which meridian system is used, a different type azimuth is described:

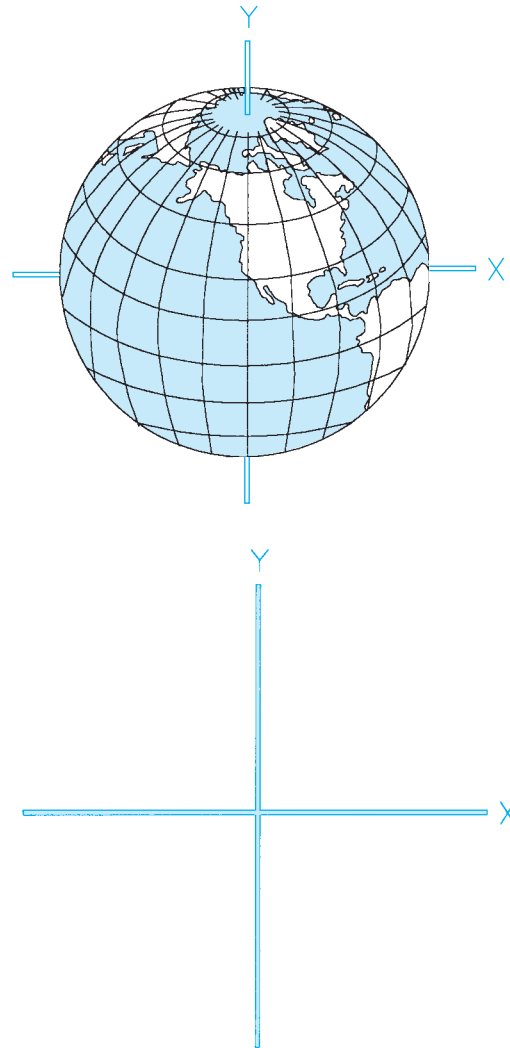
- **True azimuth** is measured from a true meridian.
- **Magnetic azimuth** is measured from a magnetic meridian.
- **Grid azimuth** is measured from a central meridian on a grid system.
- **Assumed azimuth** is measured from an arbitrary meridian.

## Bearings

The **bearing of a line** is basically the same as the azimuth, except it only has values up to  $90^\circ$ , whereas the azimuth goes through all four quadrants of the grid up to  $360^\circ$ . A bearing is also described by the north or south meridian and by the east or west parallel. For example, a line in the northwest quadrant (using the X- and Y-coordinates) that has a horizontal angle of  $45^\circ$  counterclockwise from the north meridian would be described as having an azimuth reading of  $315^\circ$ , whereas its bearing would be  $N45^\circ W$  ( $360^\circ - 45^\circ = 315^\circ$ ). A line  $75^\circ$  to the east from the south meridian has an azimuth of  $150^\circ$  and a bearing of  $S75^\circ E$ . Note that a bearing of  $S75^\circ E$  has the same angle as a bearing of  $N75^\circ W$  (see Figure 24.10).

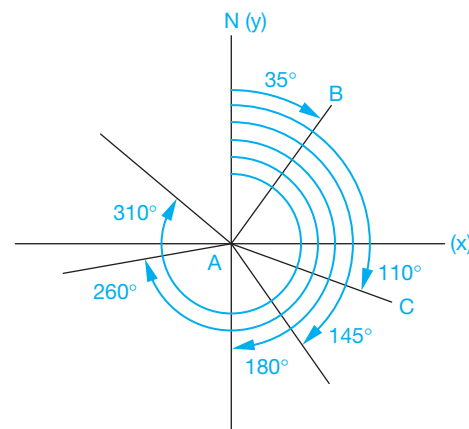
## Magnetic Azimuth

The bearings explained so far have been gauged from a true azimuth or from true north or south. The magnetic north and south are not at the actual north and south poles where the meridians meet, and where Earth spins on its axis. Figure 24.11 shows the position of the true poles and the magnetic poles. The needle of the compass points to these magnetic poles. The degree of



© Cengage Learning 2012

FIGURE 24.8 Coordinates.



© Cengage Learning 2012

FIGURE 24.9 Azimuth angles.

difference on the compass between magnetic azimuth and true azimuth is called **magnetic declination**. To adjust for this difference, isogonic lines have been established that show how many degrees to the east or west the magnetic pole is from the actual

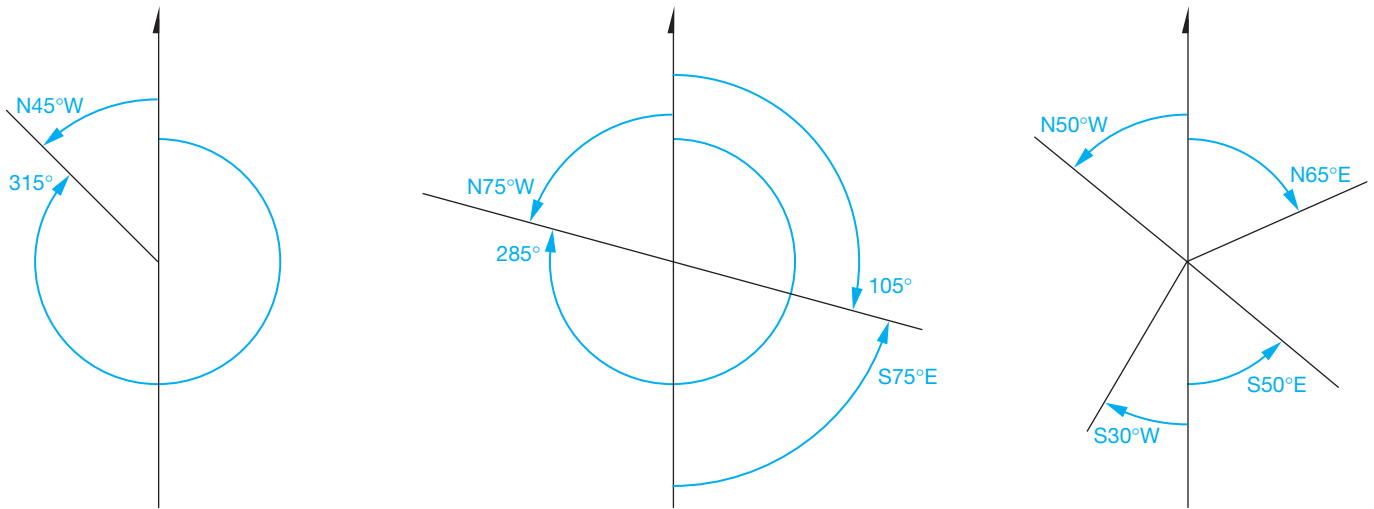


FIGURE 24.10 Bearing examples.

© Cengage Learning 2012

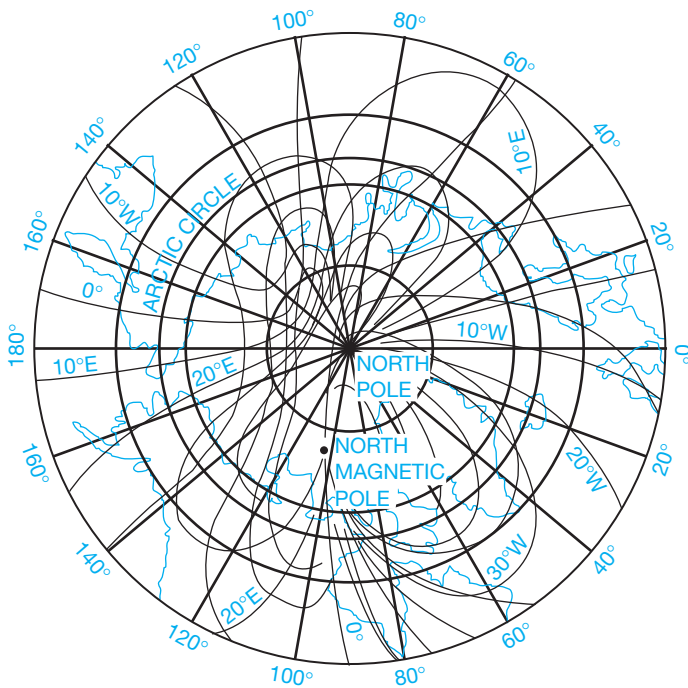


FIGURE 24.11 Azimuthal equidistant projection. © Cengage Learning 2012

pole. The isogonic lines must be reestablished periodically because the position of the magnetic pole is constantly changing. Therefore, a map showing an arrow for a magnetic pole also gives the year in which the magnetic declination was calculated.

An example of an **isogonic chart** showing isogonic lines or magnetic declination for the United States is shown in Figure 24.12. This chart, which is based on the U.S. Geological Survey of 1983, shows Chicago, Illinois, as being on the line of zero declination, also known as the **agonic line**. This means that the magnetic north pole is directly in line with the actual north pole and the compass reading is the actual north pole reading, or true azimuth. Los Angeles, California, is approximately 14.3°E

of zero declination. This means that when the compass reads 0°, it is pointing toward magnetic north, which is 14.3° east of true north. Therefore, the north arrow on any map around Los Angeles appears as in Figure 24.13.

### Grid Azimuth

The **grid azimuth** is measured from the central meridian in a rectangular grid system. This will be discussed later. It is common in maps to find three north arrows to define true azimuth, magnetic azimuth, and grid azimuth, as shown in Figure 24.14.

## SURVEYING

Civil engineering drafting is involved in displaying a portion of Earth. Now that you know about positioning and direction, you can proceed to an understanding of surveying.

### Traverses

A **traverse** is a series of lines, each with a known length and connected by known angles. Each traverse line is a **course**, and each point where courses intersect is a **traverse station** or **station point**. When traversing, you start with a **point of beginning (POB)** and proceed to utilize one of several traverse types.

#### Open Traverse

An **open traverse** does not close on itself, meaning that the courses do not return to the POB. It is used for route surveys when mapping linear features such as highways or power lines. An example is shown in Figure 24.15.

#### Closed Traverse

In a **closed traverse**, (1) the courses return to the POB or (2) the courses close on a point different from the POB but a point that has a known position called a **control point**. Figure 24.16 shows both a **loop traverse** and a **connecting traverse**. The connecting

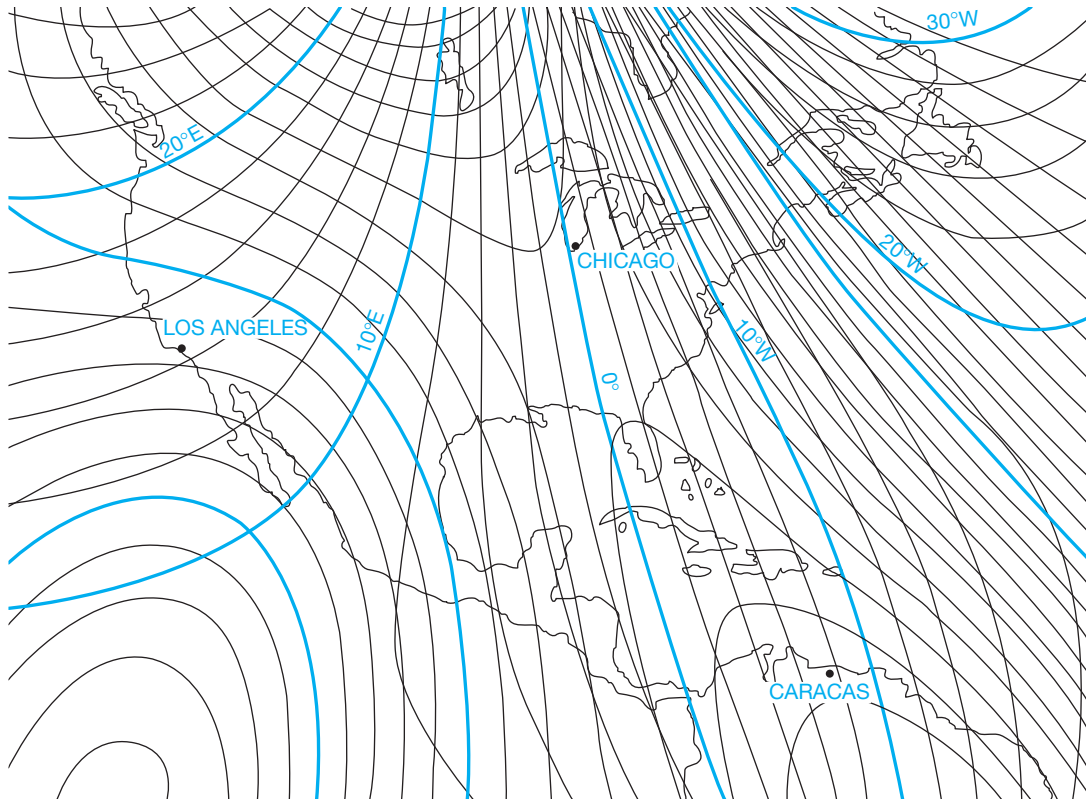
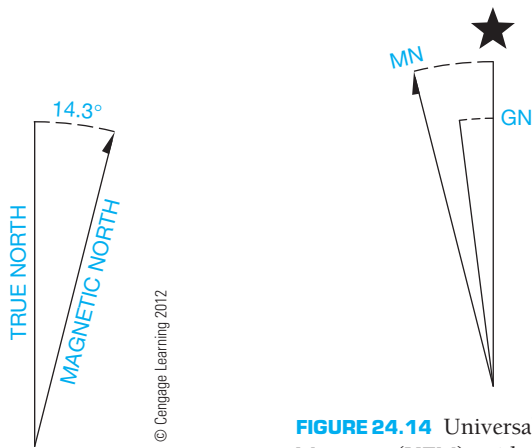


FIGURE 24.12 Isogonic chart.

© Cengage Learning 2012



© Cengage Learning 2012

FIGURE 24.14 Universal Traverse Mercator (UTM) grid and 1983 magnetic north declination at center of sheet.

FIGURE 24.13 Approximate mean declination, 1983.

traverse has known positions at both the POB and at the end of the survey. They are similar in that each can be checked for accuracy. These traverses are the ones used exclusively for land and construction surveys.

### Direct-Angle Traverse

A **direct-angle traverse** is used primarily with a loop traverse. The interior angles are measured as the traverse proceeds either clockwise or counterclockwise.

### Compass-Bearing Traverse

In a **compass-bearing traverse**, the bearings of the courses are read directly from the compass (see Figure 24.17). When using a compass, you must be aware of the magnetic declination at that particular point.

### Deflection-Angle Traverse

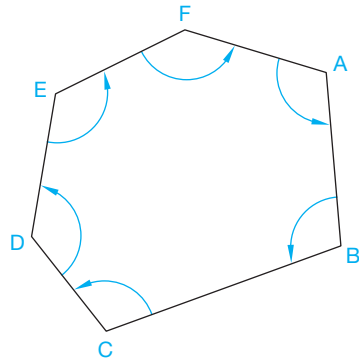
In a **deflection-angle traverse**, each course veers to the right or left from each station measured. Figure 24.18 shows that an R or an L (right or left) must always be shown with the angle. This method is used most often when doing route surveys for features such as highways and railroads.

### Azimuth Traverse

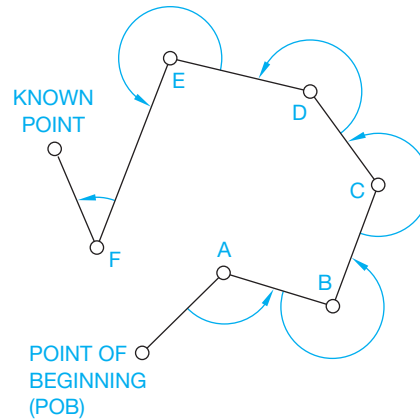
An **azimuth traverse** uses the azimuth angle to show the direction of the next course. The azimuth reference line is usually the north–south line and can either be the magnetic azimuth or



FIGURE 24.15 Open traverse. © Cengage Learning 2012



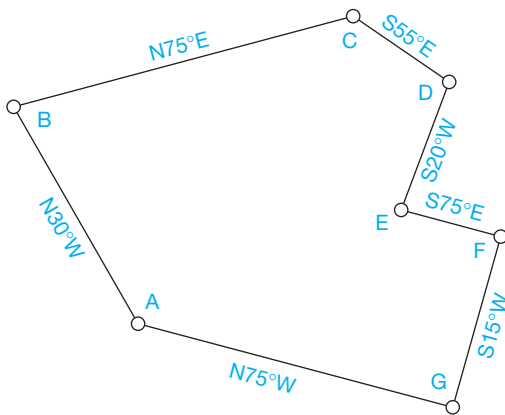
LOOP TRAVERSE



CONNECTING TRAVERSE

© Cengage Learning 2012

FIGURE 24.16 Closed traverses.



© Cengage Learning 2012

FIGURE 24.17 Compass-bearing traverse.

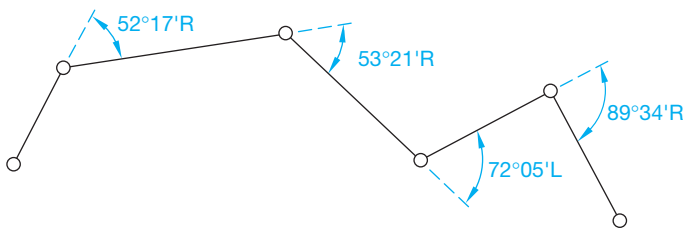


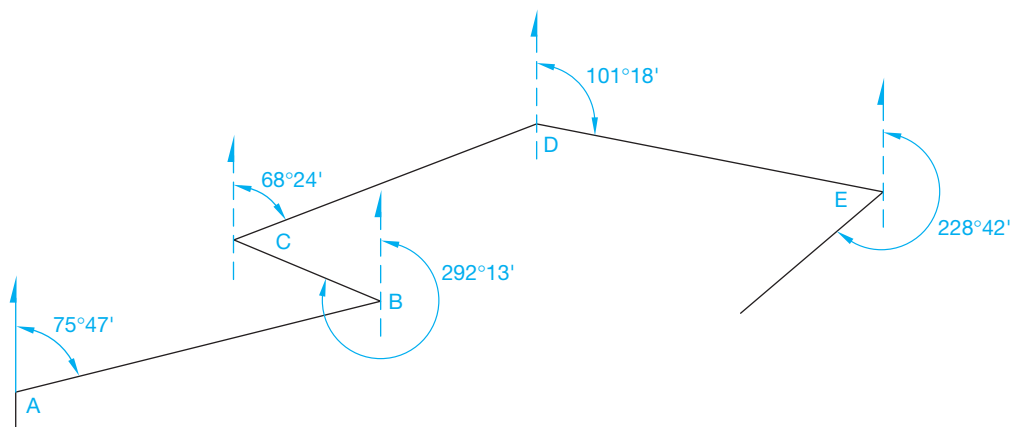
FIGURE 24.18 Deflection-angle traverse. © Cengage Learning 2012

the true azimuth. Remember that the azimuth is always measured clockwise from north (see Figure 24.19).

### PLOTTING TRAVERSES

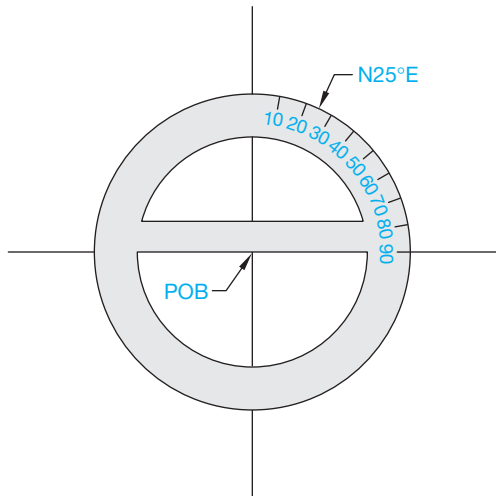
As used here, the term **plotting** refers to the layout or drafting of a traverse by establishing the end points of bearings enclosing the traverse. Plotting used in this sense is not to be confused with plotting a drawing, such as making a hard copy, when using a CADD system. The term **course**, as used in this discussion, refers to each element or line of the traverse. As with other types of drafting, you should do construction work with a light blue pencil or very lightly drawn construction lines. Follow these steps when plotting a traverse using manual drafting.

- STEP 1** Begin by drawing a light vertical north–south line on the drawing surface. Mark the POB wherever you want on the vertical line, then draw another light line horizontally through the POB.
- STEP 2** When plotting a compass-bearing traverse, the next step is to place the center of a protractor on the POB. If the bearing of the course from POB is, for example, N25°E, then make a mark on the drawing surface at the point shown in Figure 24.20.



© Cengage Learning 2012

FIGURE 24.19 Azimuth traverse.



© Cengage Learning 2012

FIGURE 24.20 Step 2: Using a protractor.

**STEP 3** Next, remove the protractor and draw a line through the POB to the  $N25^\circ E$  mark. This is the bearing line, which is one element of the course. The other necessary component of the course is the distance. If that distance is 314 feet, then measure from the POB 314 feet along the bearing line using a scale that has been previously determined (for example,  $1'' = 100'$ ). Make a mark at that point, as shown in Figure 24.21.

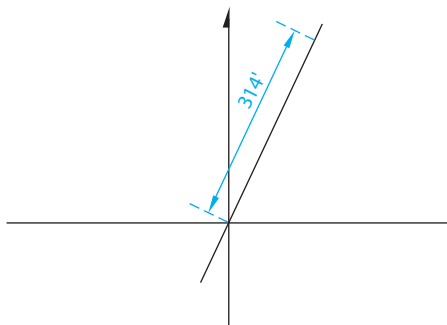
**STEP 4** Draw another north–south line through that point and plot the next compass-bearing traverse.

**STEP 5** Continue this process until you have constructed each line of the traverse.

**STEP 6** Draw all final traverse lines as thick object lines, unless otherwise specified by your company or school standards.

There is a major point to keep in mind when plotting traverses. It was mentioned earlier that a bearing of  $N25^\circ E$  and a bearing of  $S25^\circ W$  have the identical angle. However, when actually plotting the distance on the course, you must plot in the direction that is given. Otherwise, the 314 feet in Figure 24.21 is measured to the southwest from the POB instead of to the northeast.

When plotting traverses with a CADD system, the same concepts are used. Depending on the particular system you are using, the layout of the traverse follows certain steps. For



© Cengage Learning 2012

FIGURE 24.21 Measuring length.

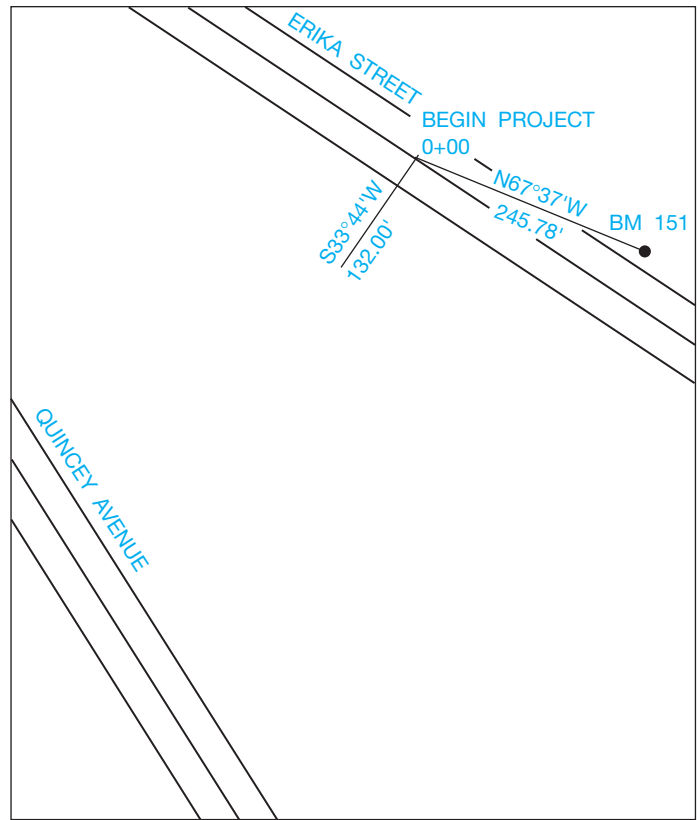


FIGURE 24.22 Finding the point of beginning (POB). © Cengage Learning 2012

example, a line can begin at the POB and then be given information relating to the length and bearing, azimuth, or other data. The system then draws the line automatically.

The direct-angle traverse is drawn by plotting the measured interior angles and by using the lengths given for each course.

A deflection-angle traverse is drawn similarly to the direct-angle traverse except that the length of each course is measured and plotted. Then the deflection angle to the right or the left is measured from that point.

The azimuth traverse is plotted similarly to the compass-bearing traverse except that the complete counterclockwise angle is measured from north. Measure each course from information given, make another north–south line at that point, and then plot the next course (see Figure 24.19).

In the example at the beginning of the chapter, the POB of the project is a specific length and distance from BM 151. BM refers to **benchmark**, which is discussed later. Now you know how to find the point of beginning and the first distance of Valerian Lane (see Figure 24.22).

## DISTANCE AND ELEVATION

So far you have learned how to establish the direction of a line by using the different azimuths and the bearing of the line. Now you need to know how to calculate the distance and the elevation in order to complete your basic knowledge of making accurate maps.

Edmund Gunter, the mathematician who invented terms such as **cosine** and **cotangent**, also invented a standard of land measurement called **Gunter's chain**, which is simply referred to as **chain**. A chain is 66 feet long, or 1/80th of a mile. It was used extensively in the days before steel tape became common. Each chain is divided into 100 links, each of which is 7.92 feet long. Because of the widespread and long-term use of Gunter's chain, terminology such as **breaking chain**, **rear chainman**, and **head chainman**, all of which are described shortly, is still used.

Distance in modern-day usage is measured in several ways. The most common is the **stadia** technique. With this method, a rod, called a **Philadelphia rod**, is used along with a level, which is an instrument with crosshairs used to read measurements on the rod at a level line of sight. The Philadelphia rod is 7 feet long, can be extended up to 12 or 13 feet long, or up to 45 feet long in some models, and is graduated to hundredths of a foot. Figure 24.23 shows a Philadelphia rod. The level is placed on a tripod a certain distance away from the rod. When you look through the level at the rod, the top stadia crosshair and the bottom stadia crosshair encompass an amount that is then multiplied by 100 to equal the distance (see Figure 24.24). In this example, the crosshairs encompass the distance between 10 and 11 feet. When multiplied by 100, the distance to the rod is 100 feet.

This type of surveying technique uses mechanical and optical principles and uses **mechanical/optical principles (MOD)** instruments. Another technique is **electronic distance measuring (EDM)**, which uses electronic principles. The EDM system is unique in that it uses a reflected beam to gauge distances (see Figure 24.25). Examples of **theodolites** and **transits**, which are instruments of the EDM system, are shown in Figure 24.26, page 1081. Theodolites and transits are used instead of compasses because they are more accurate. The magnetic declination is taken into account by an adjustment that can be made on the instrument.

The Philadelphia rod and level or transit also can be used to find the elevation of an unknown point. The method is as follows:

- STEP 1** A known elevation is located, and the rod is placed at that point.
- STEP 2** The transit (or level) is placed between the rod and the unknown elevation and then leveled.
- STEP 3** A reading is taken back to the rod. The rod location is called the **backsight**. When this height is added to the known elevation, calculate the **height of the instrument (HI)**.
- STEP 4** The rod is then placed on the unknown elevation, which is called the **foresight**, and a reading is taken forward to the rod from the transit. What is read on the rod is then subtracted from the HI to find the unknown elevation.

To find unknown elevations that are a great distance away from the known elevation, several turning points are required. **Turning points** are locations where the rod is placed (see Figure 24.27).

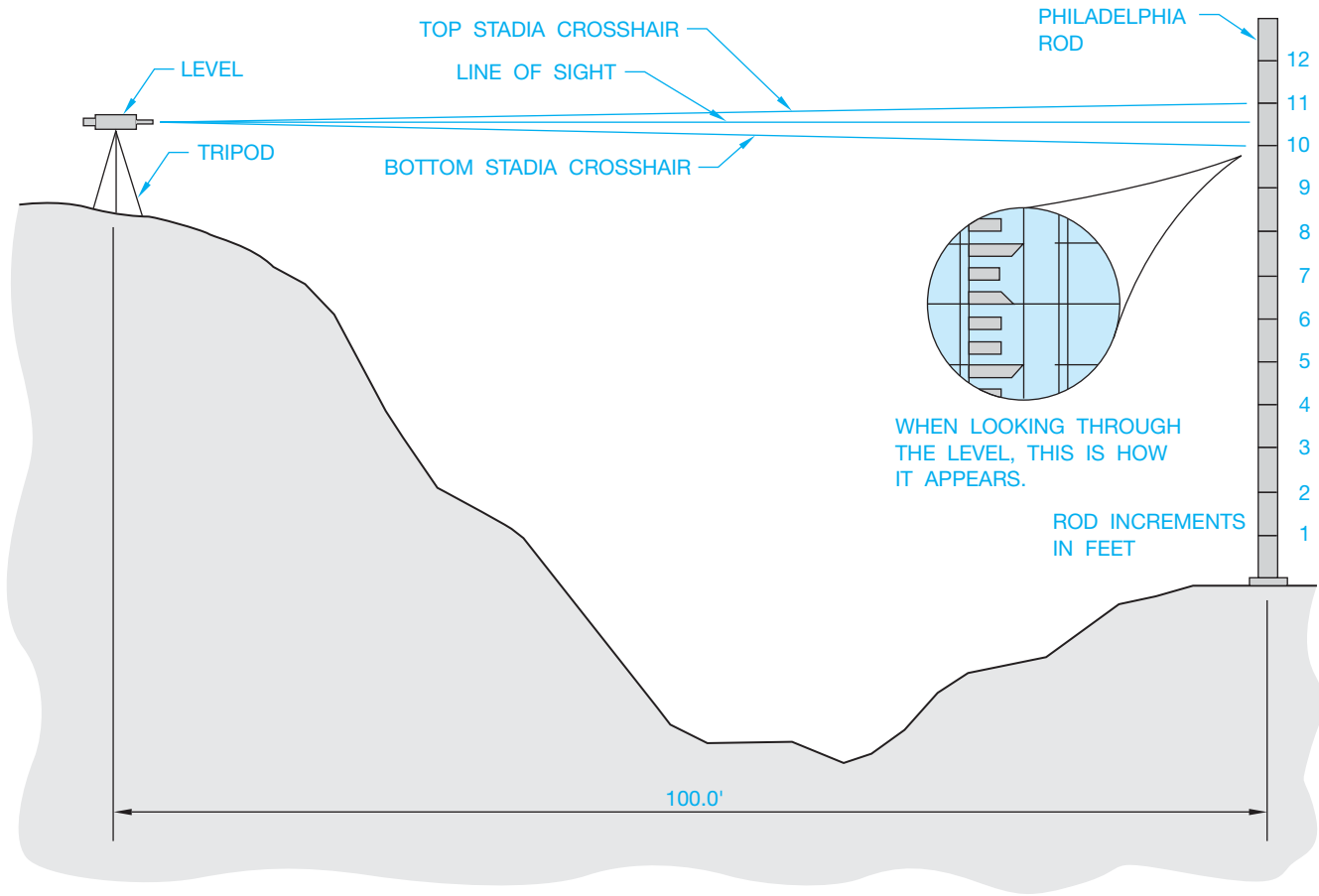


**FIGURE 24.23** Philadelphia rod. *United States Navy*

When distances are first measured using Gunter's chains, the method for finding elevations is similar to what was just described. The difference is that, instead of using an instrument such as a transit between the rod readings, the chain is held level between the rods. Then the elevations are read, and the chain is then brought to the next level to be read again. This is known as **breaking chain**, referred to earlier. The person holding the chain at the backsight is the rear chainman, and the person holding the chain at the foresight is the head chainman. This process is called **leveling** (see Figure 24.28).

A known elevation can be read from a bench mark or a monument, which is considered a permanent, fixed object on which the elevation is marked. Often a bench mark is a brass disk about 3 in. in diameter that may have U.S. GEOLOGICAL SURVEY engraved on it, along with the elevation above sea level. Another way to describe turning points is temporary bench marks or stations, often abbreviated as **STA**.

When the surveyor begins a survey, the stations, or turning points, are shown in different ways. The distances are sectioned



© Cengage Learning 2012

FIGURE 24.24 Stadia technique.

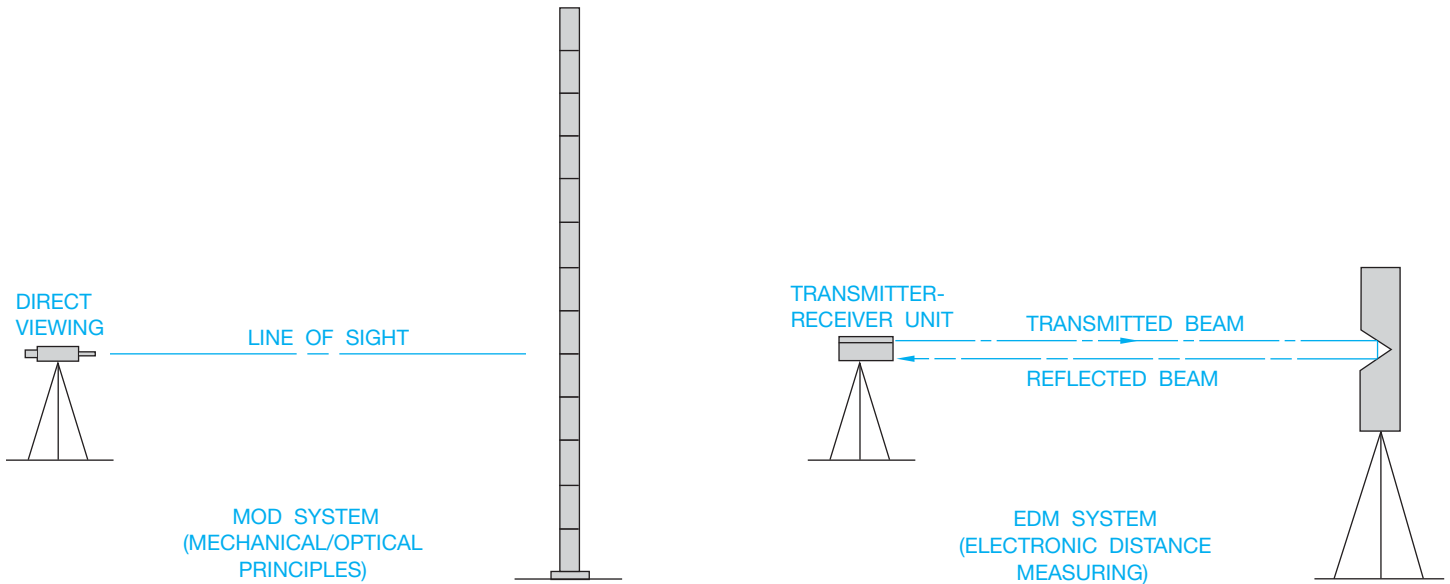


FIGURE 24.25 MOD and EDM systems. © Cengage Learning 2012

into 100 foot intervals, with the 100s separated from the 10s by a plus (+) sign. For example, the POB is shown as 0 + 00. If the next station is at 57 feet, it is shown as 0 + 57. If the following station is at 254 feet, it is shown as 2 + 44. The beginning of a survey (station 0 + 00) is always positioned according to a known

bench mark so exact locations and elevations can be calculated. A station can also be shown as a turning point. An example would be TP1, meaning turning point 1. BM 35, meaning bench mark 35, can be one of the stations. In Figure 24.29, the surveyor has given these notes to the drafter. These surveyor notes are called



FIGURE 24.26 (a) Transit (optical) theodolite. (b) Electronic theodolite. (c) Total station theodolite. Courtesy Leica Geosystems AG, Switzerland, 2011

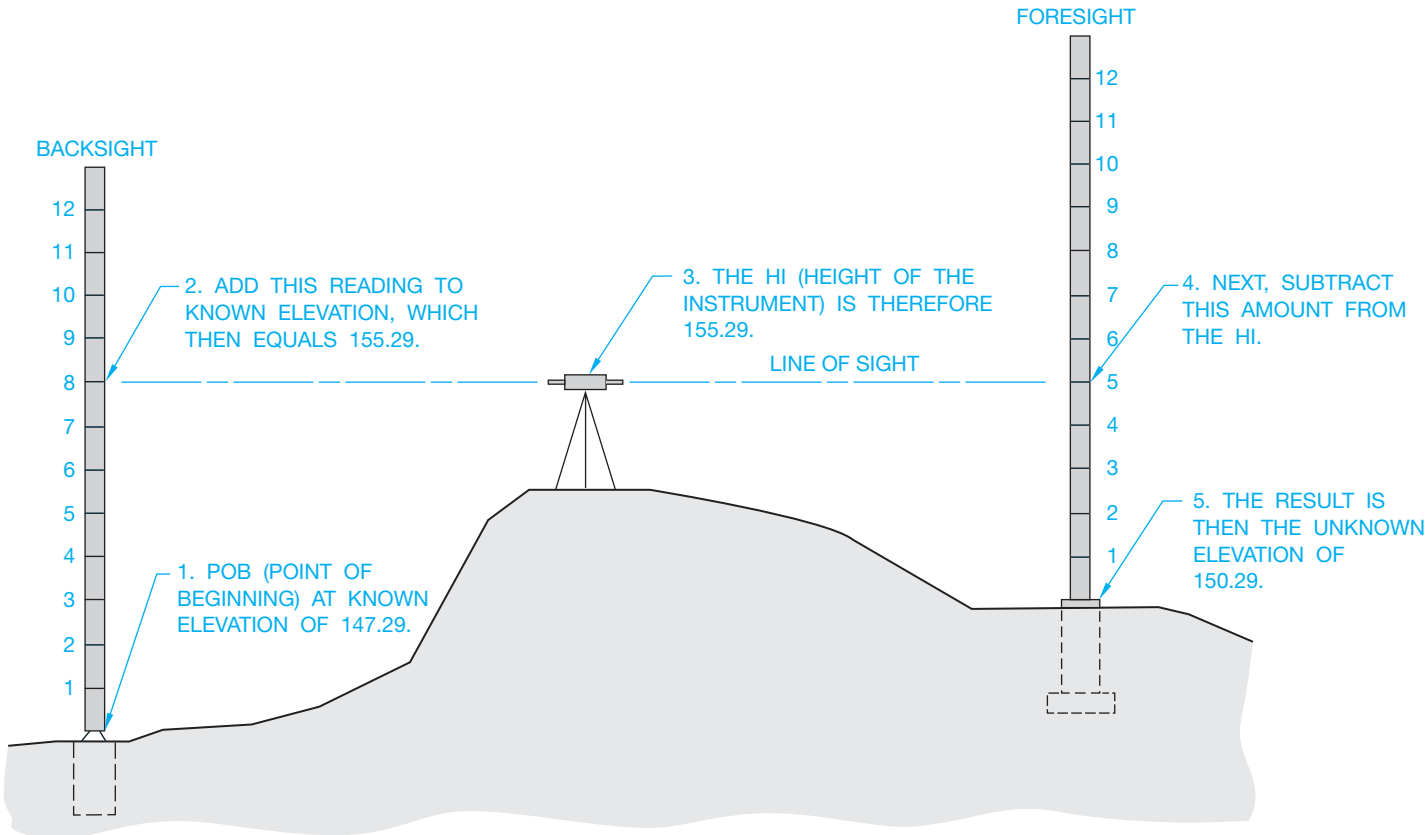
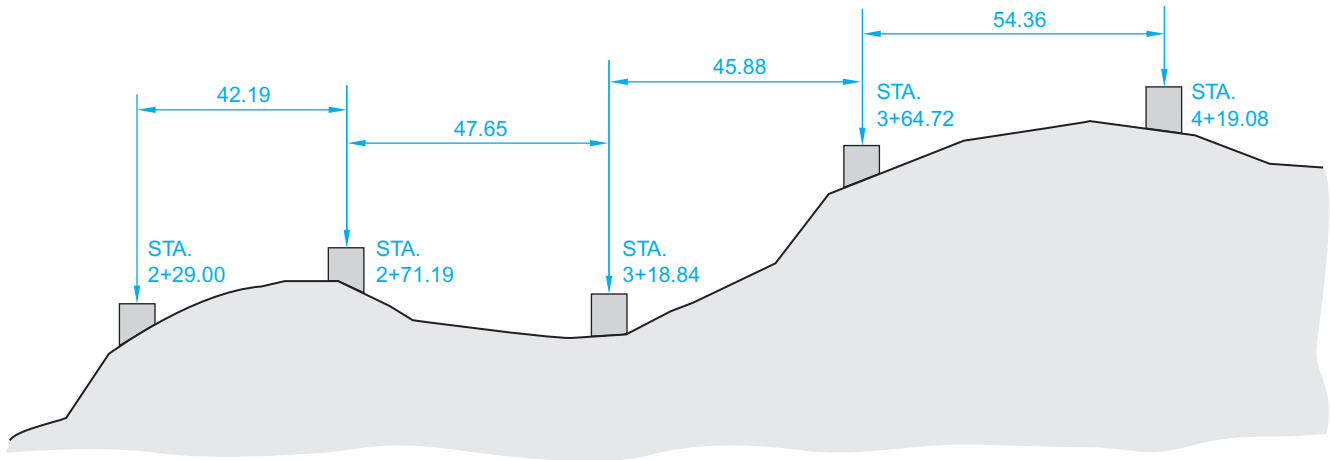


FIGURE 24.27 Elevation reading. © Cengage Learning 2012





© Cengage Learning 2012

FIGURE 24.28 Leveling.

Station	B.S. (+)	H.I.	F.S. (-)	Elevation
BM 34	7.25		11.92	124.13
0 + 75	5.87		10.29	
1 + 50	5.57		12.62	
TP1	7.04		3.44	
2 + 25	11.70		6.54	
BM 35 116.75				

FIGURE 24.29 Leveling field notes from the surveyor. © Cengage Learning 2012

Station	B.S. (+)	H.I.	F.S. (-)	Elevation
BM 34	7.25	131.38	11.92	124.13
0 + 75	5.87	125.33	10.29	119.46
1 + 50	5.57	120.61	12.62	115.04
TP1	7.04	115.03	3.44	107.99
2 + 25	11.70	123.29	6.54	111.59
BM 35 116.75				116.75

FIGURE 24.30 Leveling field notes completed by a drafter. © Cengage Learning 2012

field notes. The drafter then calculates the rest of the information, as shown in Figure 24.30. BM 35 can be double-checked to see if the calculation actually adds up to the posted elevation.

## PROPERTY DESCRIPTIONS IN CIVIL ENGINEERING

In general, civil engineering drafting can be used in a wide variety of applications: highway and traffic design, water and sewage design, park planning, subdivision planning,

single-family residence planning, and design, to name a few. When describing parcels or plots of land, there are three primary types of legal descriptions used. One method of describing land parcels is the **metes and bounds system**, and the other is the **rectangular system**, which is based on the **public-land system**. The third method used to describe land is the **lot and block system**, which can be a combination of the other systems and is used to describe lots within a subdivision. These terms are defined later.

A **parcel of land**, such as where your home is located, is often referred to as a **plot**, **lot**, or **site**. This parcel typically has its boundary lines established by a legal description containing very specific information about location, property line lengths, and bearings using one of the methods used to describe land, or a combination of methods.

### Metes and Bounds System

When the United States was first formed, the method used for describing the boundaries of properties was by measuring the length (metes) and bearings (bounds) of the property. The metes and bounds system is the primary form of legal description for 19 states, including the original 13 states. These states are not part of the public-land system where the rectangular system of surveys is used. Metes and bounds are occasionally used in public-land system states as shown in the following example (see Figure 24.31).

Beginning at the northwest corner of that certain tract of land conveyed to James H. Wilcox *et ux* by Deed recorded in Film Volume 95, Page 1488, Deed Records of Yamhill County, Oregon, said point is in the center of County Road No. 87, thence along the center of said County Road No. 87, N57°45'W 16.49 feet; thence N69°33'W 213.18 feet; thence leaving said County Road No. 87, S22°29'W 400.00 feet more or less to a point on the North bank of the Yamhill River; thence Easterly along said North bank of the Yamhill River to the Southwest corner of the aforesaid James H. Wilcox *et ux* tract of land; thence along the West line thereof N22°29'E 360.00 feet more or less to the point of beginning.

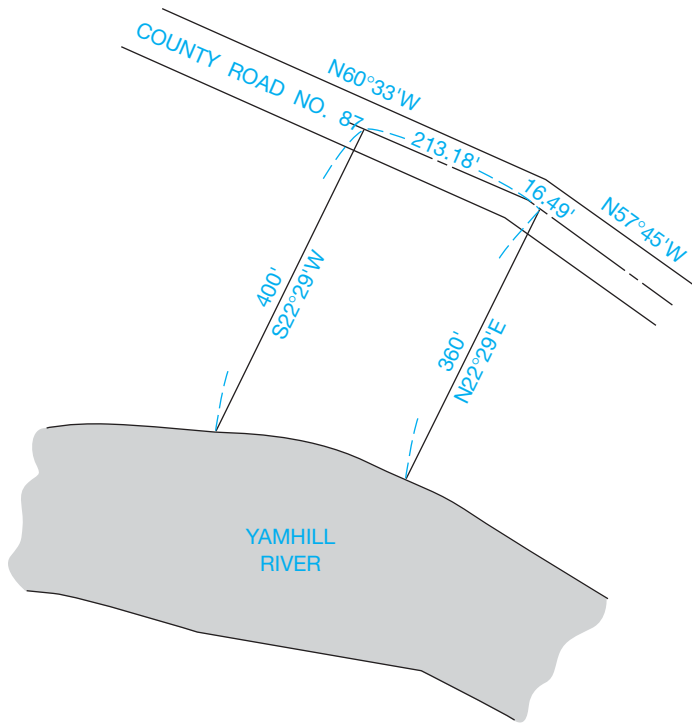


FIGURE 24.31 Metes and bounds tract of land. © Cengage Learning 2012

## Rectangular System

In the late 1700s, when the remaining land to the Pacific Ocean was opened up to homesteading, a more complete and universal method of determining land ownership was needed. The government, through the General Land Office, which is now known as the Bureau of Land Management, measured large areas in these public lands and provided a rectangular system of surveys from which ownership can be determined. The public-land states are Alabama, Alaska, Arizona, Arkansas, California, Colorado, Florida, Idaho, Illinois, Indiana, Iowa, Kansas, Louisiana, Michigan, Minnesota, Mississippi, Missouri, Montana, Nebraska, Nevada, New Mexico, North Dakota, Ohio, Oklahoma, Oregon, South Dakota, Utah, Washington, Wisconsin, and Wyoming, in addition to 75 million acres of Texas bought by the federal government. Each large area of public land was a single great survey and had a basic reference point where one specific meridian of longitude and one specific parallel of latitude crossed. The meridians in each of these public-land surveys were named separately with names such as the *first principal meridian* (which is the western boundary of the state of Ohio), *Michigan meridian*, *Choctaw meridian*, and the *Black Hills meridian*. The parallels were all named **baseline**. There are 31 sets of great surveys in the contiguous United States and three in Alaska.

With the baseline and principal meridian as reference points, each survey is arranged into rows of 6-mile-square blocks, each having an area of 36 square miles called **townships**. From the baseline, each row of townships can be located by referring it to the number and direction from the baseline. For example, a township just to the north of the baseline is identified as Township No. 1 North or abbreviated T1N, and a township in a row

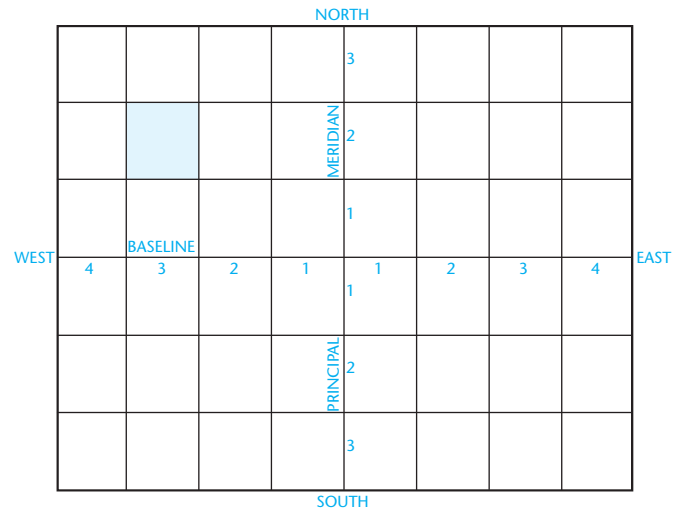


FIGURE 24.32 Baseline and meridian. © Cengage Learning 2012

6	5	4	3	2	1
7	8	9	10	11	12
18	17	16	15	14	13
19	20	21	22	23	24
30	29	28	27	26	25
31	32	33	34	35	36

FIGURE 24.33 Township divided into sections. © Cengage Learning 2012

of townships three rows south of the baseline is Township No. 3 South or T3S. The townships are also arranged according to columns called **ranges**, and each column of townships can be located from the principal meridian by referring to how far east or west it is from the meridian. For example, a township in a column of townships four columns to the east of the principal meridian is labeled Range No. 4 East or R4E. The marked township in Figure 24.32 is T2N, R3W.

Each of the township's 36 squares is called a **section**, with the sections numbered as shown in Figure 24.33. Each section is approximately one square mile and can be divided into quarter-sections, which are sometimes referred to as **quarters**. An example is the southwest quarter of Section 19, which can also be written SW 1/4 of Sec. 19. The quarter-sections can be divided further into quarter-quarter-sections, as seen in Figure 24.34. Notice that the description of the particular piece of land begins with the smallest portion and proceeds through the largest portion.

## Lot and Block System

The **lot and block** legal description system can be established from either the metes and bounds or the rectangular system. Generally when a portion of land is subdivided into individual

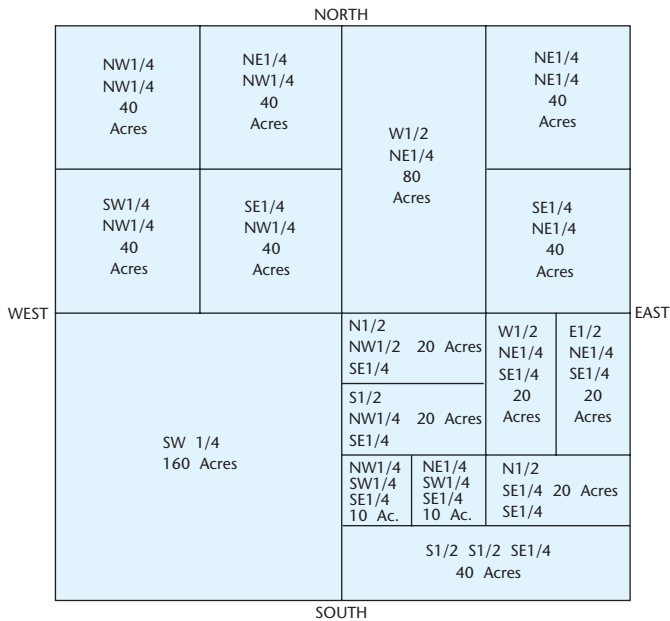


FIGURE 24.34 Section divided into parcels. © Cengage Learning 2012

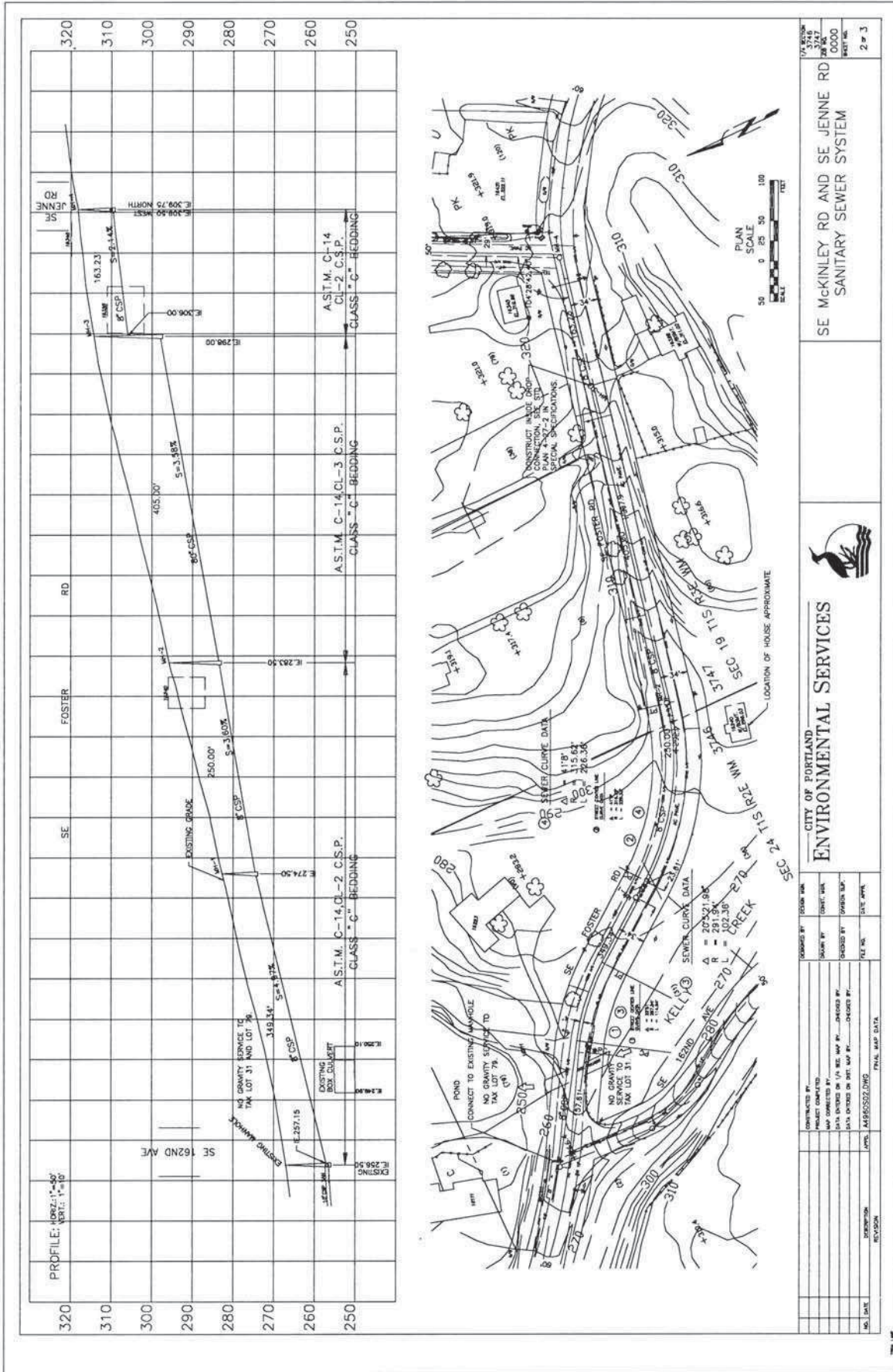
building sites, the **subdivision** is established as a legal plot and recorded as such in the local county records. The subdivision is given a name and broken into blocks of lots. A subdivision can have several **blocks**, each divided into a series of **lots**. Each lot can be 50 × 100', for example, depending on the zoning requirements of the specific area. Figure 24.35 shows an example of a typical lot and block system. A typical lot and block legal description might read: LOT 14, BLOCK 12, LINCOLN PARK NO. 3, CITY OF SALEM, STATE OF OREGON. This lot is the shaded area in Figure 24.35.

## BEGINNING A CIVIL ENGINEERING DRAFTING PROJECT

An **engineering map** is a large-scale map showing the information necessary for planning an engineering project such as a highway layout or utility layout. The information can come from an engineering survey, an aerial survey, or other reliable source, and it includes locations, dimensions, and elevations of buildings, roads, water, and utility lines. This type of map can also include contour lines in addition to showing the boundaries of plats (see Figure 24.36). A **plat** is a tract of land, such as a subdivision, showing building lots (see Figure 24.35). Notice also the section, township,



FIGURE 24.35 Part of a lot and block subdivision. Courtesy GLADS Program



**FIGURE 24.36** Engineering map. Printed by Permission of the City of Portland

and range notations. WM is an abbreviation for Willamette meridian, which is the name of the meridian in this great land survey.

### Contour Lines

One of the most important symbols in civil engineering drafting is the **contour line**. Contours are lines joining points of the same elevation. When looking at a map with contours, you are able to understand the topography of the land. Figure 24.37 shows the relationship between actual elevations and how the contour lines appear on the map. Each horizontal plane represents an additional 10 feet in elevation from the horizontal plane below it. The contour interval in this case is 10 or 10 feet.

Figure 24.38 shows the contour lines around Mount St. Helens in Washington state. The contour lines are spaced more closely together on steep slopes than they are on gentle slopes. They also point upstream when depicting creeks.

Some of the contours are drawn with a heavier line than others. These are **index contours** and can occur every fourth or fifth contour, depending on the map. Some of the index contours are labeled with their elevations. **Intermediate contours** are the lighter lines shown between the index contours, and they are not usually labeled with elevations. In the Mount St. Helens map, find the index contour at 8000 feet of elevation. The next downhill index contour that is labeled is at 7600 feet. This means the index contour between these two is at 7800 feet,

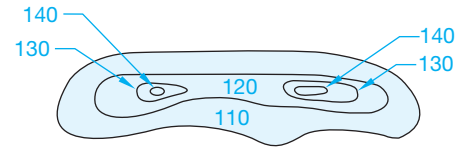
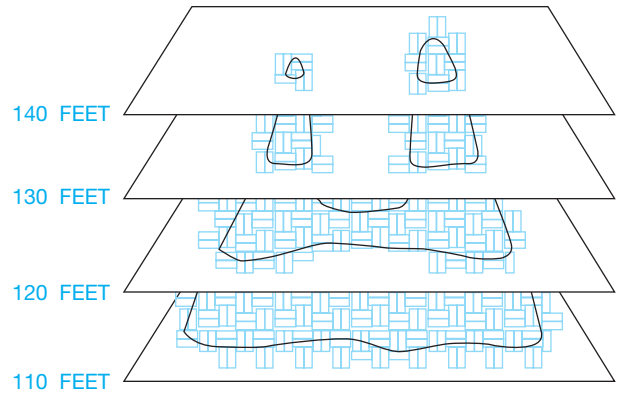


FIGURE 24.37 Contours.

and each intermediate contour is at 40 feet intervals. There are four intermediate contours between index contours. The contour interval is 40 feet, and this interval is stated on the map. There is an additional discussion of constructing contour lines later in this chapter.

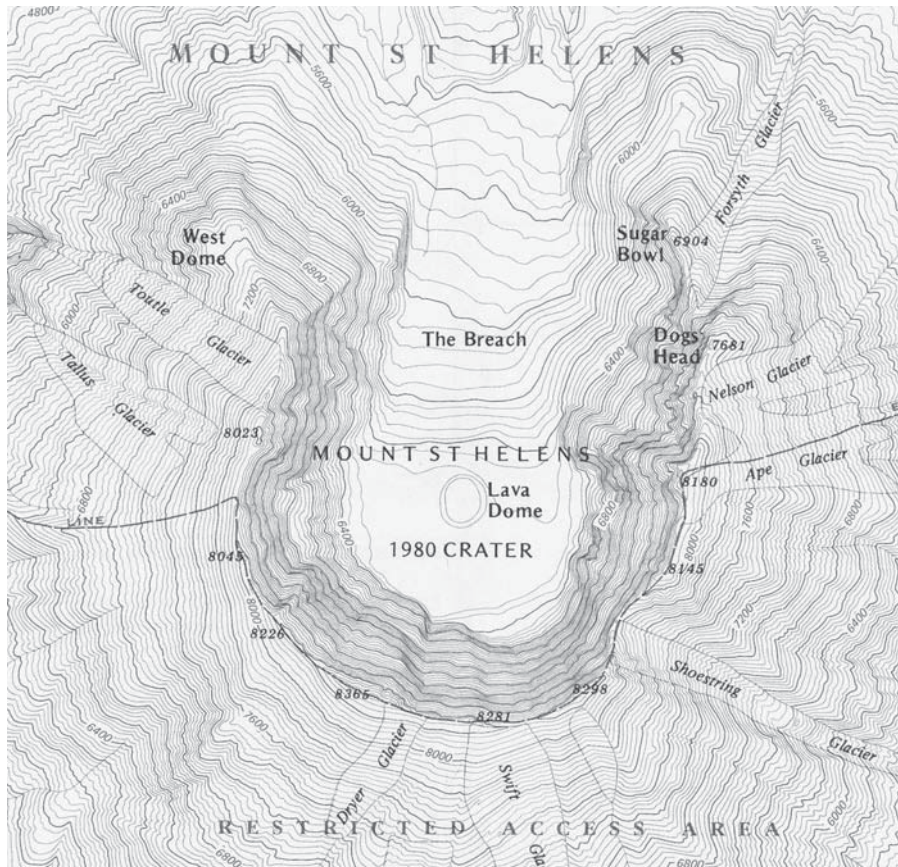


FIGURE 24.38 Contour intervals of Mount St. Helens.

© Cengage Learning 2012

Printed by Permission U.S. Geological Survey

## Highway Layout

For a highway layout, you first draw a **plan view** and then a **profile** of the proposed highway from the information given in the survey notes. The plan view shows existing features such as roads, buildings, and trees in addition to the centerline (transit line) of the proposed highway. The profile is a section view through the plan at a specific location.

### Plan View Layout

To plot the transit line of the highway, use **curve data** information like that shown for the sewer layout in Figure 24.36. The following is basic terminology related to this application.

**Transit line** is any line of a survey established by a transit or other surveying instruments.

Curve data is any measurements or features used to create the road layout. The following terms are used in curve data:

- **Point of curve (PC)** is the station at which the curve begins.
- **Radius (R)** means the radius of that particular curve. The center point of the curve can be found by measuring the radius distance perpendicularly from the transit line at the PC. For example, to find the center of a curve with a radius of 265 feet in which the transit lines are known, draw two lines parallel to the transit lines on the inside of the curve. Their intersection is the center of the curve (see Figure 24.39).
- **Point of tangency (PT)** denotes the end of the curve.
- **Delta angle ( $\Delta$ )** is the inclusive angle measurement of the curve from the PC to the PT.
- **Curve length (L)** is the actual length of the curve from the PC to the PT.
- **Degree of curve (D)** is the angle within the delta angle that has a chord of 100 feet along the curve. A chord connects two points on the curve with a straight line.
- **Point of reverse curve (PRC)** is the point where two curves meet and curve in different directions.

The simplified layout in Figure 24.40 shows the relationship of the transit lines with the curve data.

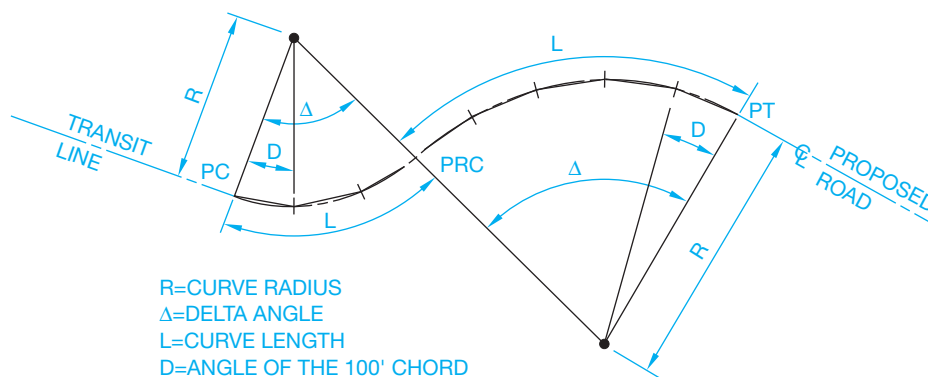


FIGURE 24.40 A simplified highway layout.

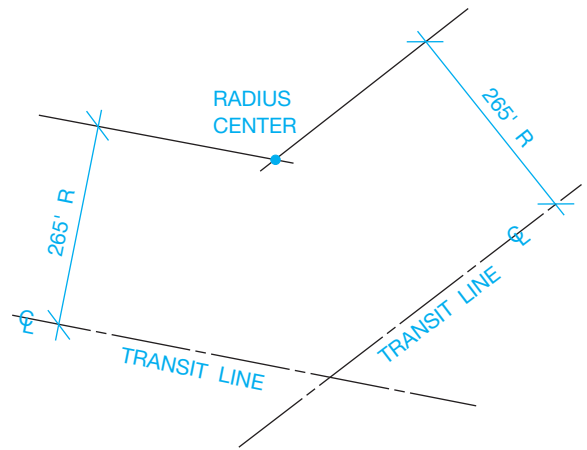


FIGURE 24.39 Locating radius center of highway curve.

Station points are given at all significant points along the transit line such as the PC, PRC, PT, and other features such as utility crossings and railroad crossings.

Fill in some of the information in the example at the beginning of the chapter. The mathematical equation for the length of the curve is

$$L = (\pi R \Delta) \div (180)$$

Therefore, for the first curve in Figure 24.42, the length is

$$[(3.1416)(200)(47^{\circ}23')] \div 180, \text{ or } 165.40'$$

One way to calculate the degree of curve is to imagine the 100 foot chord is divided in half. Then imagine a triangle is made from the radius length (200 feet), the 50 foot length, and the default length to the center of the curve (see Figure 24.41). The sine of the angle at the center of the curve is the opposite side (50 feet) divided by the hypotenuse (200 feet). This number is 0.25. The inverse of the sine gives you the angle, which is  $14.477^{\circ}$  or  $14^{\circ}28'39''$ . Twice this amount, which is the value for the full 100 foot chord, is rounded to  $28^{\circ}57'$ , or the degree of curve.

Because you know the length of the first curve in Figure 24.42 is 165.40', you know that the PRC stationing is 1 + 65.40 added

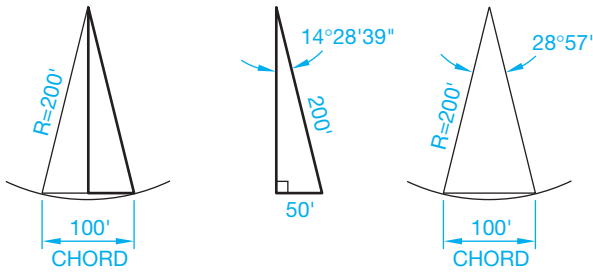


FIGURE 24.41 Plotting curves. © Cengage Learning 2012

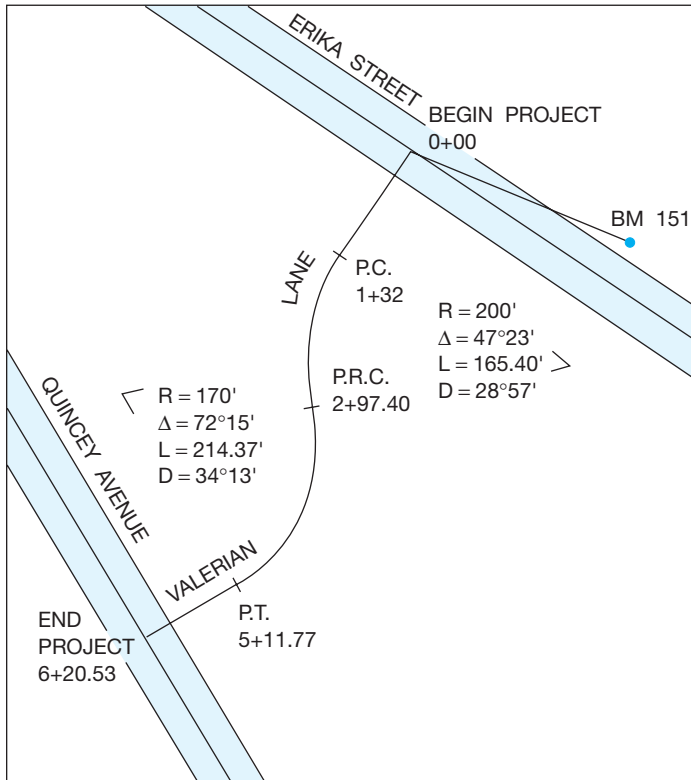


FIGURE 24.42 Finding delta for Figure 24.1. © Cengage Learning 2012

to 1 + 32.00, which equals 2 + 97.40. Other information for Figure 24.42 can now be calculated and drawn (see Figure 24.43).

You can also receive survey notes that establish a **point of intersection (PI)** of a curve instead of a PC or PT. A point of intersection is where two transit lines converge if a curve is not taken into account. Figure 24.39 shows an example of this application.

After the curve center is found, lines are drawn from the center perpendicularly to the transit lines. Where the perpendicular lines intersect the transit lines is the PC and the PT of the curve, and the angle that these two lines include is the delta angle ( $\Delta$ ).

After plotting the transit line of the proposed highway using either method, the right-of-ways can then be plotted by measuring from the transit line. In the example in Figure 24.43, plot the right-of-way 20 feet on each side of the transit line. The term **right-of-way** refers to an easement or deeded strip of land for

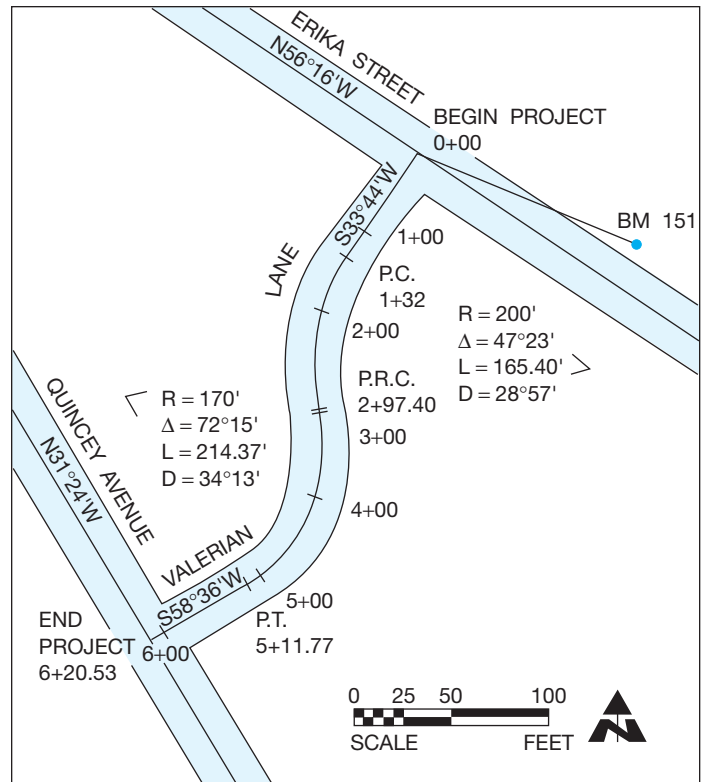


FIGURE 24.43 The completed drawing of Valerian Lane. © Cengage Learning 2012

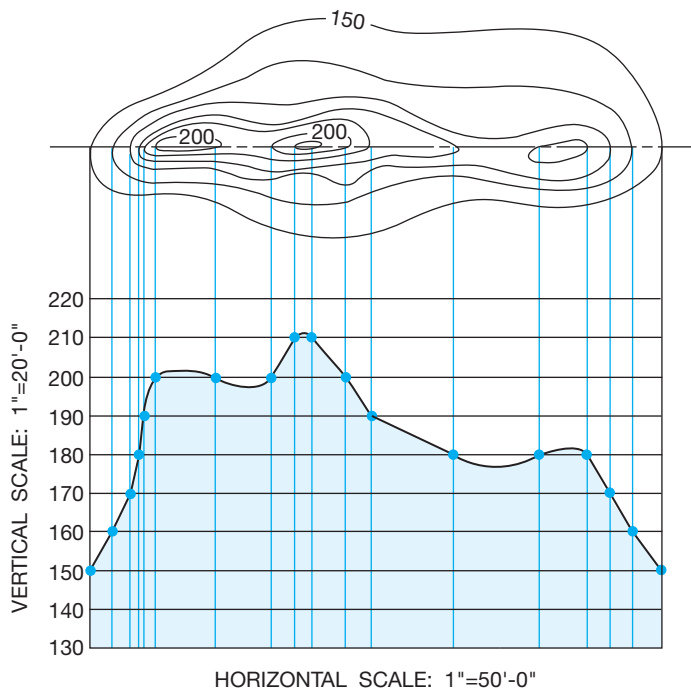
construction and maintenance of features such as roads, utilities, or other uses. The right-of-way includes the surface, underground, and overhead space at the designated strip of land. An **easement**, in this application, is a legal right of access over land owned by another for the purpose of access, egress, utilities, or other designated uses. Add station marks at every 1 + 00 station, a north arrow, and a graphic scale (see Figure 24.43).

### Profile Layout

A person's profile is what the person's face or body looks like from the side. A profile for a map is what that map looks like in elevation if a vertical slice is cut through the land. Profiles are established from the contour information of the map and information from the survey. Figure 24.44 shows a portion of a map with contours and a horizontal line through the map. The horizontal line is referred to as the **cutting line** or **cutting-plane line** and is where the section is made through the land. The cutting line can be placed other than horizontal. Follow these steps to draw a profile.

**STEP 1** Wherever the cutting line crosses a contour line, a perpendicular construction line is drawn to create the profile.

**STEP 2** A mark is made at the point where the construction line intersects with the corresponding vertical scale line. The vertical scale, constructed along the left side of the profile in Figure 24.44, is divided into parts with each division representing an elevation found in the plan layout. To establish a complete profile, the



**FIGURE 24.44** Step 2: Drawing the horizontal and vertical scales.  
© Cengage Learning 2012

scale generally starts with an elevation less than the lowest elevation in the plan and ends with an elevation greater than found in the plan. You can see this as elevations 130 and 220 in Figure 24.44. The rest of the elevations are spaced between these extremes.

**STEP 3** The marks are then connected. The resulting profile shown at the base of the figure has the same horizontal scale as the map, with an exaggerated vertical scale. An exaggerated vertical scale is common in civil drafting because it helps to visualize the slope of the land, especially in areas that are relatively flat. Horizontal scales are typically  $1" = 50'$  or  $1" = 100'$ , and vertical scales are commonly  $1" = 5'$  or  $1" = 10'$ .

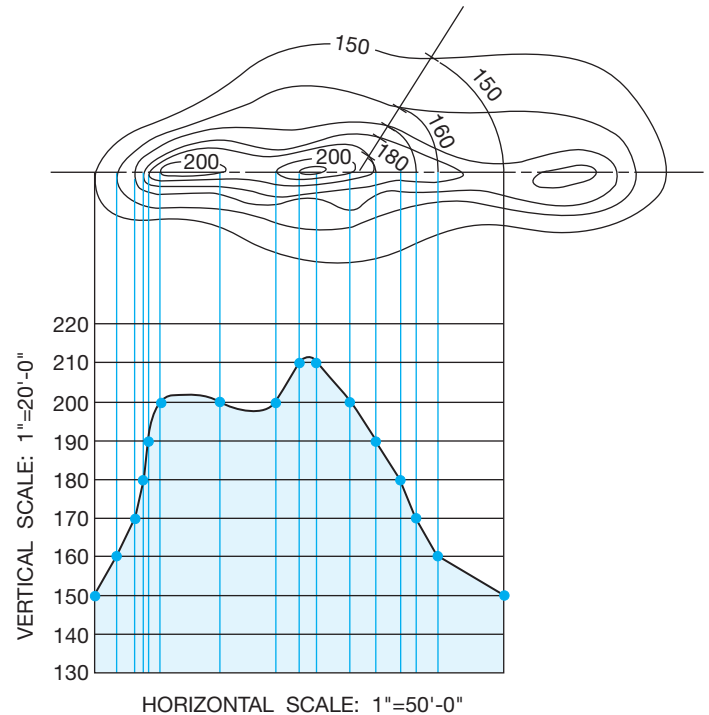
**STEP 4** Connect the points to complete the profile as shown in Figure 24.44. Figure 24.45 shows the profile drawn if the cutting line is placed through the plan at an angle.

In this example, the cutting line is horizontal from left to right until it angles up to the right just past the second 200' elevation. The part of the cutting line that is horizontal is used to construct a profile as previously discussed.

Follow these steps to create the profile with an angled cutting line. Remember the construction lines need to be perpendicular to the cutting line.

**STEP 1** Where the horizontal part of the cutting line crosses a contour line, a perpendicular construction line is drawn to create the profile as previously discussed.

**STEP 2** The angled cutting line creates a vertex where it joins the horizontal cutting line. The profile construction, at the angled cutting line, is done by drawing arcs



**FIGURE 24.45** Step 3: Drawing the horizontal and vertical scales.  
© Cengage Learning 2012

with their centers at the vertex and their radii where the angled cutting line crosses contour lines. Each arc is drawn from these points to the continuation of the horizontal line, as shown in Figure 24.45.

**STEP 3** Where the arcs meet the continuation of the horizontal cutting line, project each down into the profile, establishing points where they meet their corresponding elevation from the vertical scale (see Figure 24.45).

**STEP 4** Connect the elevation points in the profile view to complete the profile line (see Figure 24.45).

Plan and profile drawings are also used when drawing proposed utility services.

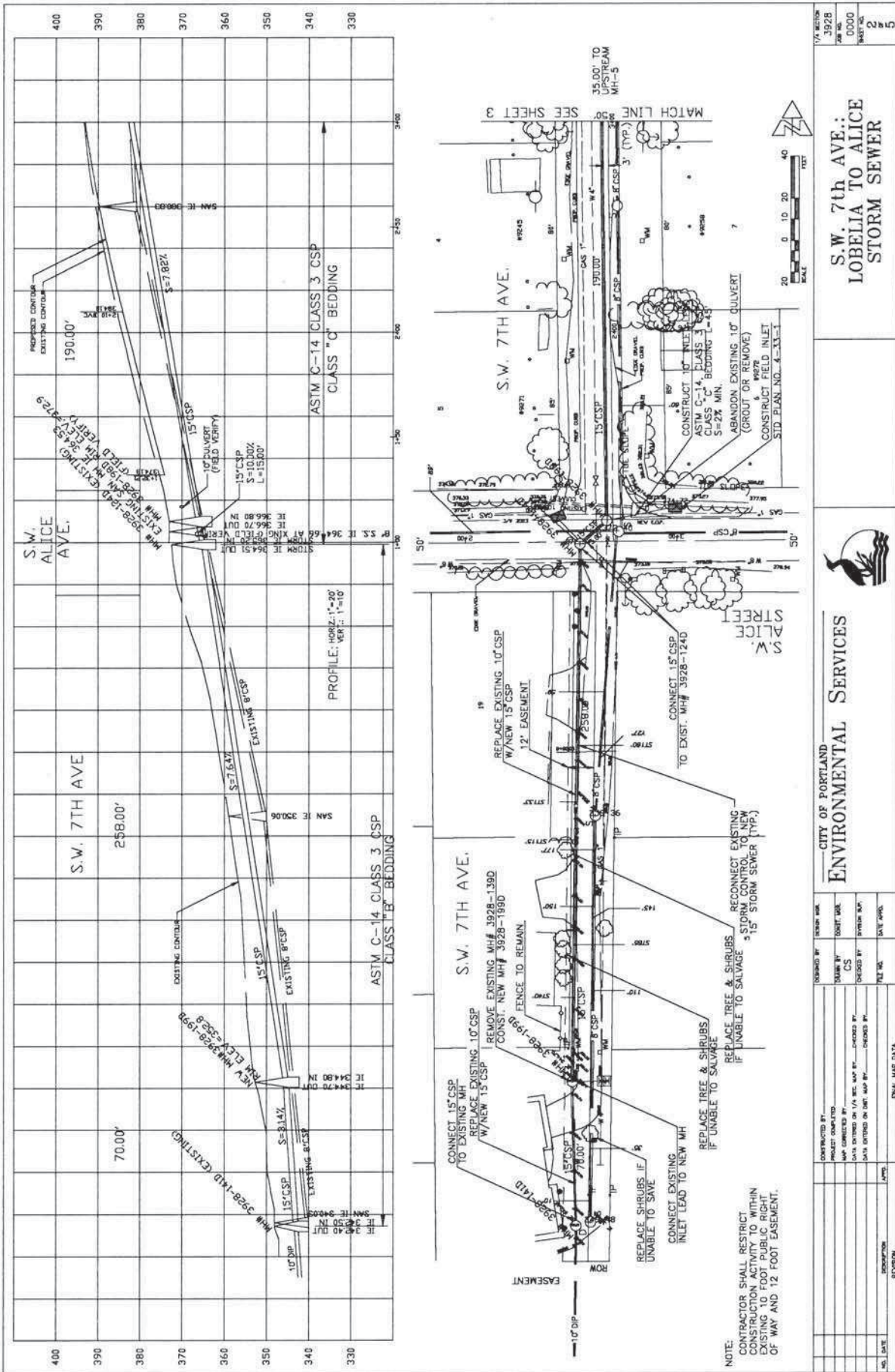
Follow these steps for this profile application.

**STEP 1** The plan of the particular utility line is plotted and drawn showing right-of-way lines, other services, and manholes, with their corresponding elevations and station points.

**STEP 2** Draw a profile of the service onto the appropriate vertical scale, usually above the plan on the drawing surface. When drawing a sewer line, for example, if the elevation at the top of MH (manhole) 1 is 76.4 feet at STA 2 + 32, then the manhole is plotted on the profile at 76.4 vertical feet. If possible, this manhole is plotted directly above the 2 + 32 station point. In cases in which the utility line makes turns and angles, this is not possible.

**STEP 3** Complete the plan and profile. An example of a plan and profile for a storm sewer layout is shown in Figure 24.46.





		<b>CITY OF PORTLAND                  ENVIRONMENTAL SERVICES</b>	
DESIGNED BY: _____ DRAWN BY: _____ CHECKED BY: _____ DATE: _____	CHECKED BY: _____ DATE: _____	PROJECT NO.: 3928 SHEET NO.: 0000 TOTAL SHEETS: 25	PROJECT TITLE: <b>S.W. 7th Ave.;                  LOBELIA TO ALICE                  STORM SEWER</b>

FIGURE 24.46 Step 3: Storm sewer plan project sheet. Printed by Permission of the City of Portland

**Invert elevation (IE)** is the lowest elevation of the inside of a sewer pipe at a particular station. The IE of a pipe is shown on the profile; it is information necessary to determine the *grade slope* of the pipe. The **grade slope** is the percentage number given to show the amount of slope of the pipe (or road) and is shown on the profile. For example, the grade slope shown in Figure 24.46 is 7.64%. Grade slope is the amount of elevation gain (or loss) divided by the distance. So, the elevation difference is 19.71 feet ( $364.51 - 344.80$ ), and the distance is 258.00 feet. The slope is 0.0764, or 7.64%.

### Vertical Curves on the Profile

A vertical curve is one that is shown on the profile when the road travels over a hill or down a valley and then up again. To draft a vertical curve, you are given the elevation points of the road from engineer or survey people, and these points are plotted on the profile grid. The following are abbreviations used when plotting vertical curves (see Figure 24.47):

- BVC (begin vertical curve)** is used at the point where the curve begins.
- EVC (end vertical curve)** is used at the point where the curve ends and the road has an even slope again.
- VC (vertical curve)** is the horizontal length of the curve from the point where it begins to the point where it ends.
- PI (point of intersection)** is the point where the two road grades intersect.

### Cut and Fill Drawing

When designing a road, highway, or building site, portions of earth must sometimes be removed (cut) from hillsides that are too steep and added (filled) to valleys and low spots. The amount of cut and fill needed can be shown on the profile, the plan, or sometimes on both. The following examines profile cut and fill in relation to planning a roadway and then in relation to a building site.

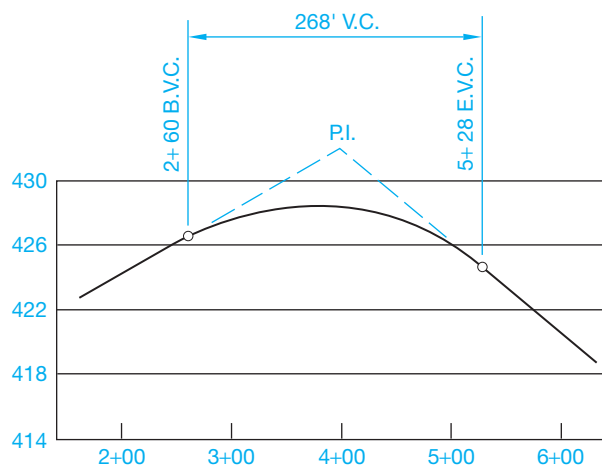


FIGURE 24.47 Layout of vertical curve.

### Roadway Cut and Fill

Follow these steps when drawing a cut and fill for a roadway.

- STEP 1** The first step in drafting the cut and fill of a roadway is to plot the roadway on the original contour plan.
- STEP 2** The necessary **cut and fill ratio** of the road is placed off the edge of the drawing surface in line with the road. This ratio is given to you by the designer or engineer and is based on information such as soil conditions. The cut and fill ratio is the relationship of run to rise (**run** being the horizontal length, and **rise** being the vertical height) and is called the **angle of repose**. The angle of repose is the design slope of the area on either side of the roadway. In Figure 24.48 the angle of repose is 2:1, and the cut and fill ratio is set up so the designed roadway has an elevation of 180 feet. The cut occurs as the elevation increases, and the fill occurs as the elevation decreases.
- STEP 3** The desired cut and fill lines from the ratio are projected onto the drawing of the road and parallel to the road. Marks are made at the intersection of the new contour intervals and the original contours.
- STEP 4** The lines connecting the marks show the boundaries of the proposed cut and fill around the road (see Figure 24.49). The building site cut and fill construction method is discussed later in this chapter.

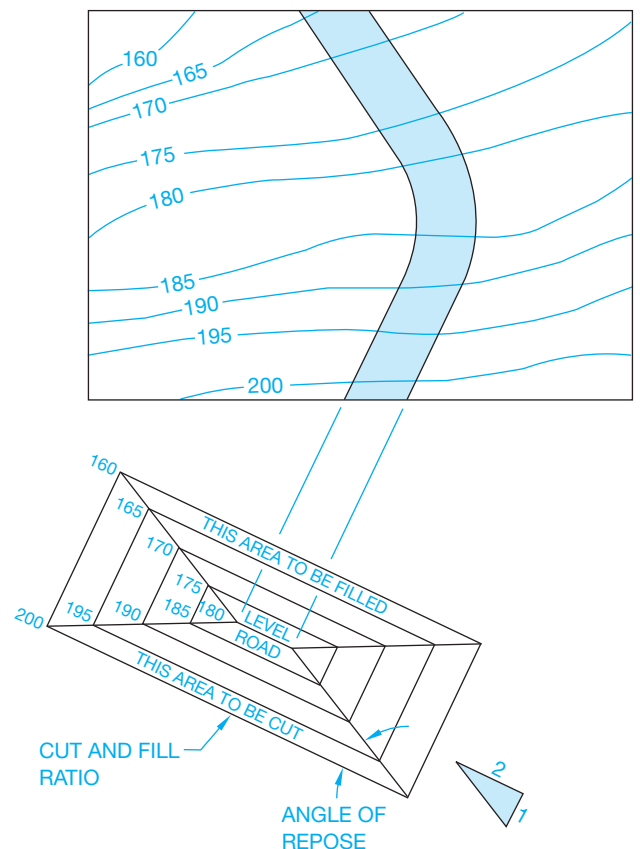
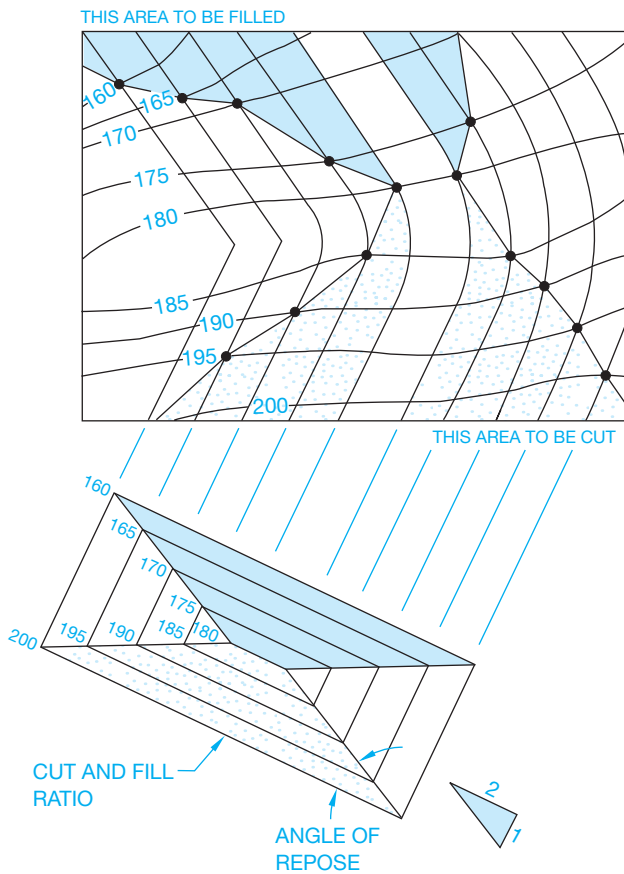


FIGURE 24.48 Step 2: Highway layout cut and fill.



© Cengage Learning 2012

FIGURE 24.49 Step 4: Highway layout cut and fill.

## INTRODUCTION TO SITE PLANS

A **site plan**, also known as a **plot plan**, is a map of a piece of land that can be used for any number of purposes. Site plans can show a proposed construction site for a specific property. Sites can show topography with contour lines, or the numerical value of land elevations can be given at certain locations. Site plans are also used to show how a construction site is excavated and are known as **grading plans**. Although site plans can be drawn to serve any number of required functions, they all have similar characteristics, which include showing the following:

- A legal description of the property based on a survey.
- Property line bearings and directions.
- North direction.
- Roads and easements.
- Utilities.
- Elevations.
- Map scale.

## Topography

**Topography** is a physical description of land surface showing its variation in elevation, known as *relief*, and locating other

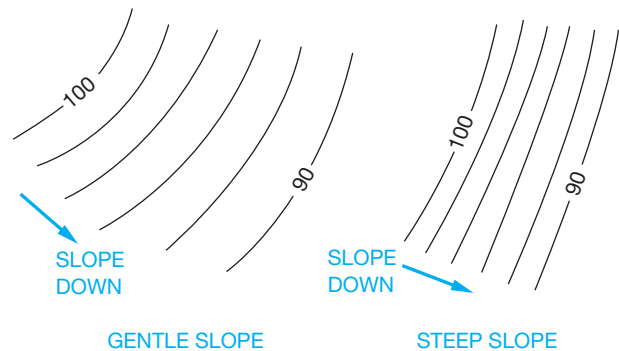
features. Surface relief can be shown with graphic symbols that use shading methods to highlight the character of land, or the differences in elevations can be shown with contour lines. Plot plans that require surface relief identification generally use contour lines. These lines connect points of equal elevation and help show the general lay of the land.

A good way to visualize the meaning of contour lines is to look at a lake or ocean shoreline. When the water is high during the winter or at high tide, a high-water line establishes a contour at that level. As the water recedes during the summer or at low tide, a new lower-level line is obtained. This new line represents another contour. The high-water line goes all around the lake at one level, and the low-water line goes all around the lake at another level. These two lines represent contours, which are lines of equal elevation. The vertical distance between contour lines is known as the **contour interval**. When the contour lines are far apart, the contour interval shows relatively flat or gently sloping land. When the contour lines are close together, the contour interval shows land that is much steeper. Drawn contour lines are broken periodically, and the numerical value of the contour elevation above sea level is inserted. Figure 24.50 shows sample contour lines. Figure 24.51 shows a graphic example of land relief in pictorial form and contour lines of the same area.

A site plan with contour lines is shown in Figure 24.52. Site plans do not always require contour lines to show topography. Verify the requirements with the local building codes. In most instances, the only contour-related information required is property corner elevations, street elevation at a driveway, and the elevation of the finished floor levels of the structure. In addition, slope can be identified and labeled with an arrow.

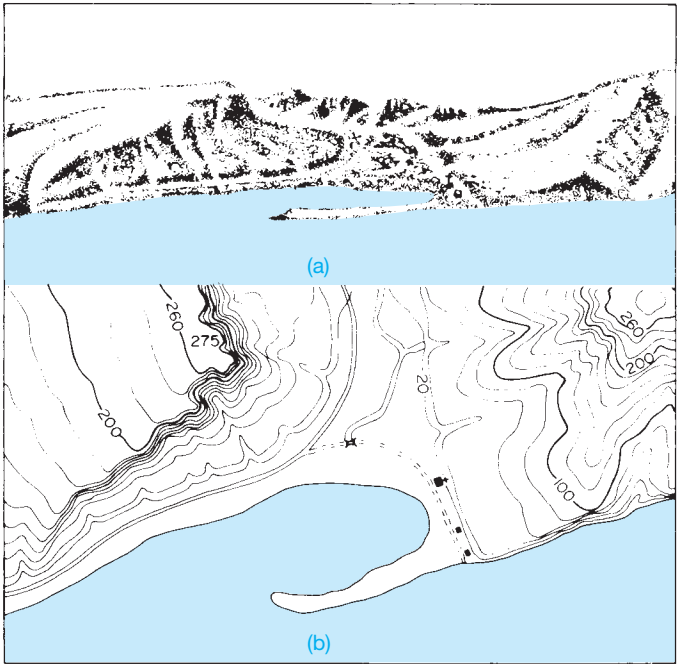
## Elements of a Site Plan

Site plan requirements vary from one local jurisdiction to the next, although some elements of site plans are similar around the country. Guidelines for site plans can be obtained from the local building official or building permit department. Some agencies, for example, require that the site plan be drawn on



© Cengage Learning 2012

FIGURE 24.50 Contour lines showing both gentle and steep slopes.

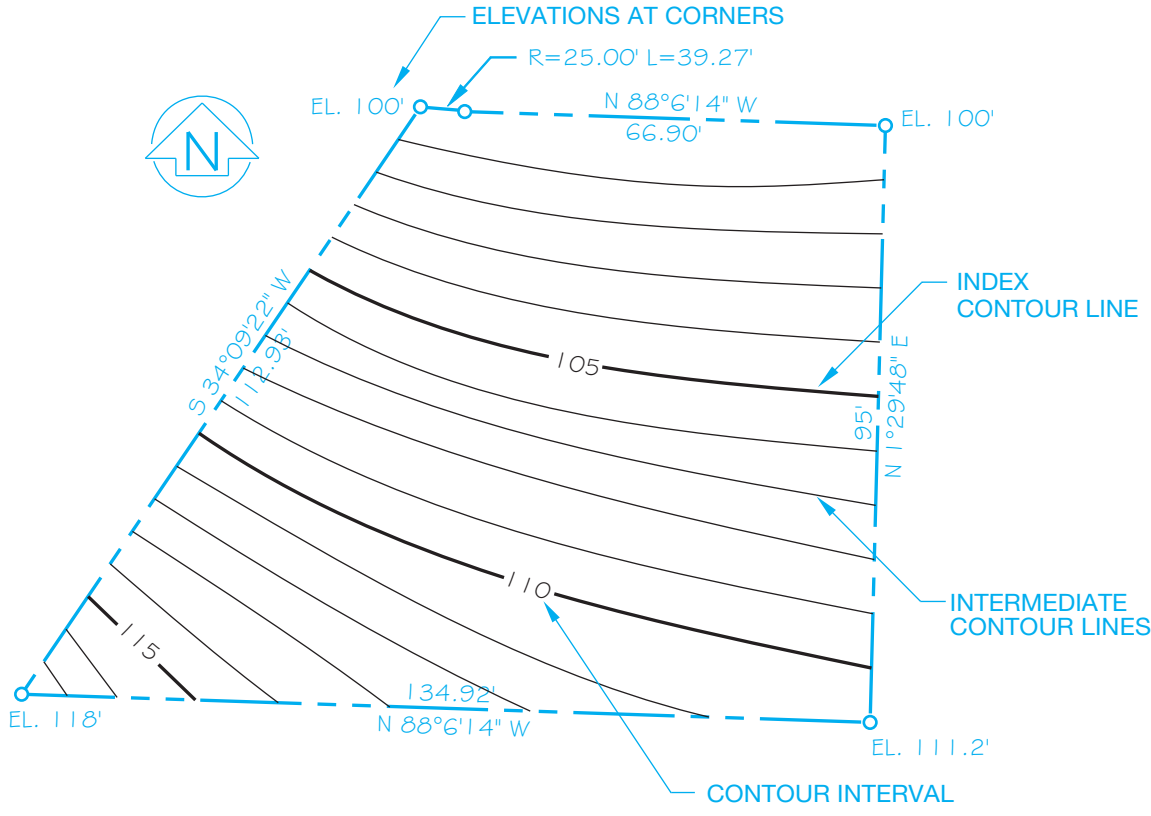


**FIGURE 24.51** (a) Land relief pictorial. (b) Contour lines of the same area. Courtesy U.S. Department of Interior, Geological Survey

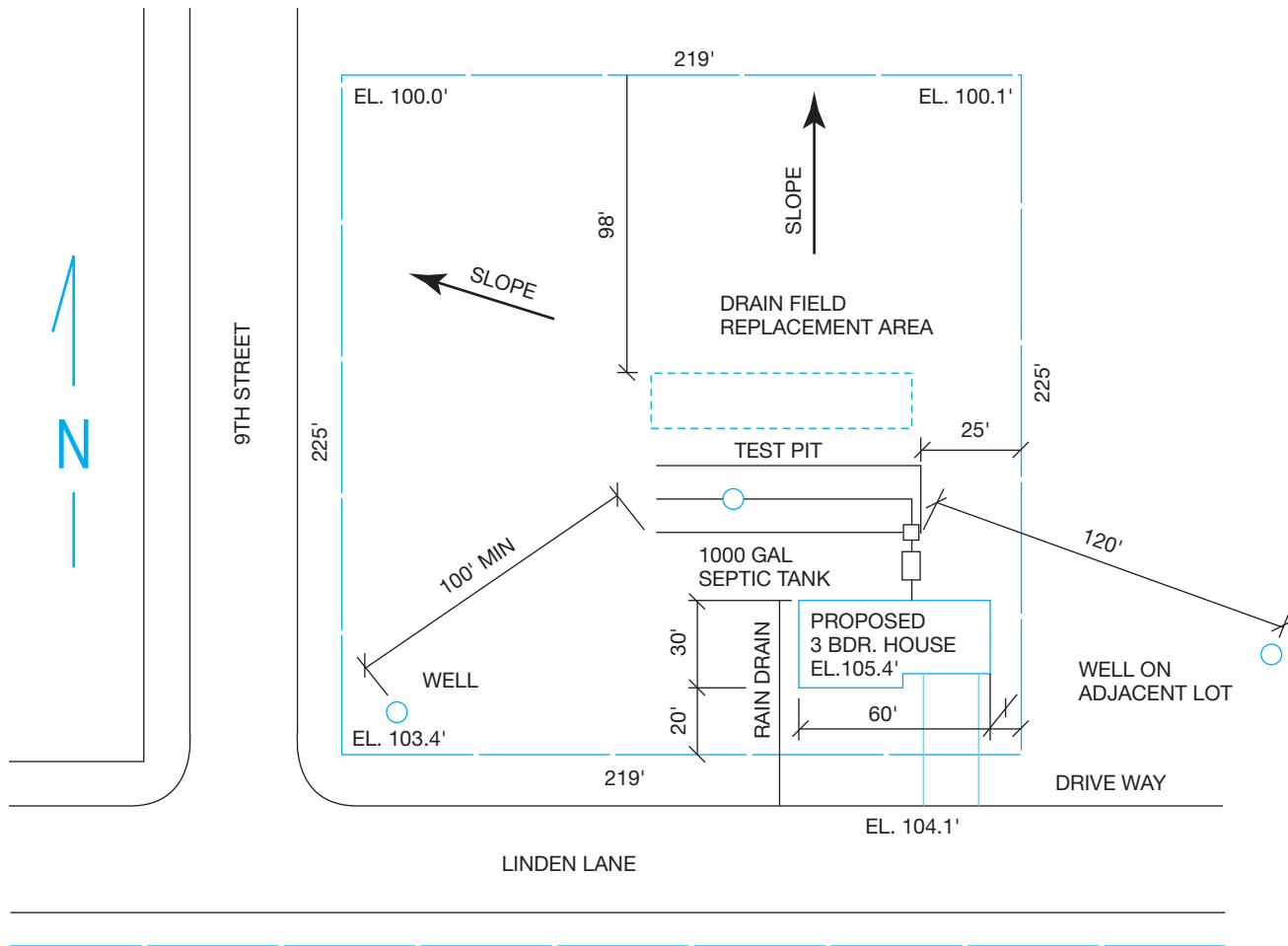
specific size paper such as 8-1/2" × 14" (A4 or A3 metric). Typical site plan items include the following:

- Site plan scale.
- Legal description of the property.
- Property line bearings and dimensions.
- North direction.
- Existing and proposed roads.
- Driveways, patios, walks, and parking areas.
- Existing and proposed structures.
- Public or private water supply.
- Public or private sewage disposal.
- Location of utilities.
- Rain and footing drains, and storm sewers or drainage.
- Topography including contour lines or land elevations at lot corners, street centerlines, driveways, and floor elevations.
- Setbacks, front, rear, and sides.
- Specific items on adjacent properties may be required.
- Existing and proposed trees may be required.

Figure 24.53 shows a site plan layout that is used as an example at a local building codes department. Figure 24.54 shows a basic site plan for a proposed residential addition.



**FIGURE 24.52** Site plan with contour lines. © Cengage Learning 2012



PLAN  
SCALE 1" = 60'

FIGURE 24.53 Recommended typical site plan layout. © Cengage Learning 2012

### Site Analysis Plan

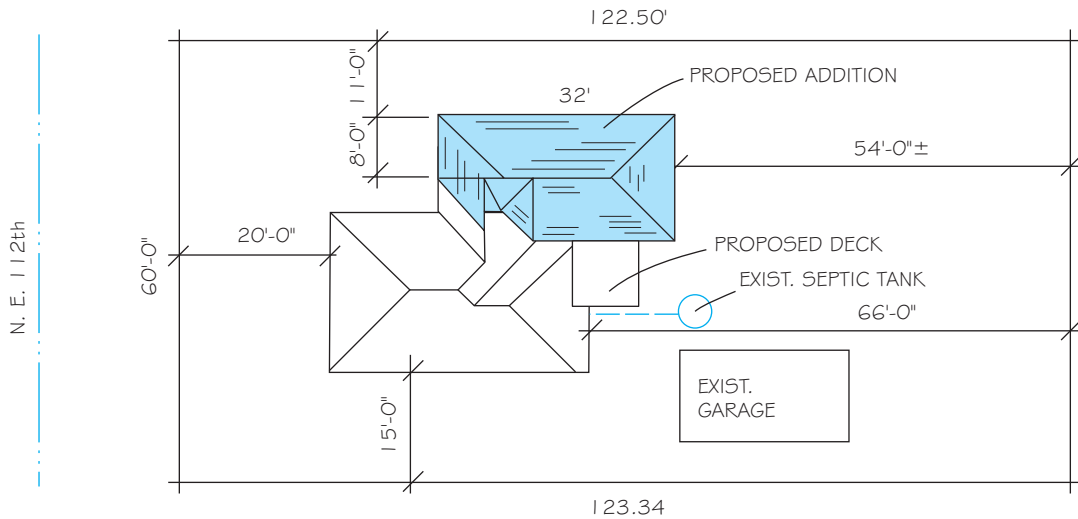
Local requirements for subdivisions should be confirmed as there are a variety of procedures depending on local guidelines and zoning rules. In areas where zoning and building permit applications require a design review, a **site analysis plan** may be required. The site analysis should provide the basis for the proper design relationship of the proposed development to the site and to adjacent properties. The degree of detail of the site analysis is generally appropriate to the scale of the proposed project. A site analysis plan, as shown in Figure 24.55, often includes the following:

- A vicinity map showing the location of the property in relationship to adjacent properties, roads, and utilities.
- Site features such as existing structures and plants on the property and adjacent property.
- The scale.

- North direction.
- Property boundaries.
- Slope shown by contour lines, cross sections, or both.
- Plan legend.
- Traffic patterns.
- Solar site information, if solar application is intended.
- Pedestrian patterns.

### Planned Unit Development

A creative and flexible approach to land development is a **planned unit development**. Planned unit developments may include such uses as residential areas, recreational areas, open spaces, schools, libraries, churches, or convenient shopping facilities. Developers involved in these projects must pay particular attention to the impact on local existing developments. Generally, the



### PLOT PLAN

1" = 20'-0"

#### LEGAL:

LOT #3  
BLOCK F1  
VIEW RIDGE  
MULTNOMAH COUNTY

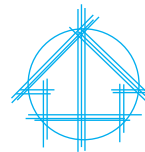


FIGURE 24.54 Sample site plan showing existing home and proposed addition. © Cengage Learning 2012

plats (site plans) for these developments must include all of the same information shown on a subdivision plat, plus:

- A detailed vicinity map, as shown in Figure 24.56.
- Land use summary.
- Symbol legend.
- Special spaces, such as recreational and open spaces, or other unique characteristics.

Figure 24.57 shows a typical planned unit development plan. These plans, as in any proposed plat plan, can require changes before the final drawings are approved for development.

There are several specific applications for a site or plat plan. The applied purpose of each will be different, although the characteristics of each type of site plan can be similar. Local districts have guidelines for the type of site plan required. Be sure to evaluate local guidelines before preparing a site plan for a specific purpose. Prepare the site plan in strict accordance with the requirements in order to receive acceptance.

## INTRODUCTION TO GRADING PLANS

Grading plans are construction drawings that generally show existing and proposed topography. The outline of the structure can be shown with elevations at each building corner and the

elevation given for each floor level. Figure 24.58 shows a detailed grading plan for a residential construction site. Notice that the legend identifies symbols for existing and finished contour lines. This particular grading plan provides retaining walls and graded slopes to accommodate a fairly level construction site from the front of the structure to the extent of the rear yard. The finished slope represents an embankment that establishes the relationship of the proposed contour to the existing contour. This grading plan also shows a proposed irrigation and landscaping layout.

Grading plan requirements can differ from one location to the next. Some grading plans also show a cross section through the site at specified intervals or locations to evaluate the contour more fully. This cross section, as previously discussed, is called a *profile*. A profile through the grading plan in Figure 24.58 is shown in Figure 24.59. Drawing a grading plan and site profile is explained later in this chapter.

## SUBDIVISION PLANS

Local requirements for subdivisions should be confirmed because procedures vary, depending on local guidelines and zoning rules.

Some areas have guidelines for **minor subdivisions** with few sites that differ from **major subdivisions** with many sites. The term *plat* refers to a map, plan, or layout of a subdivision that

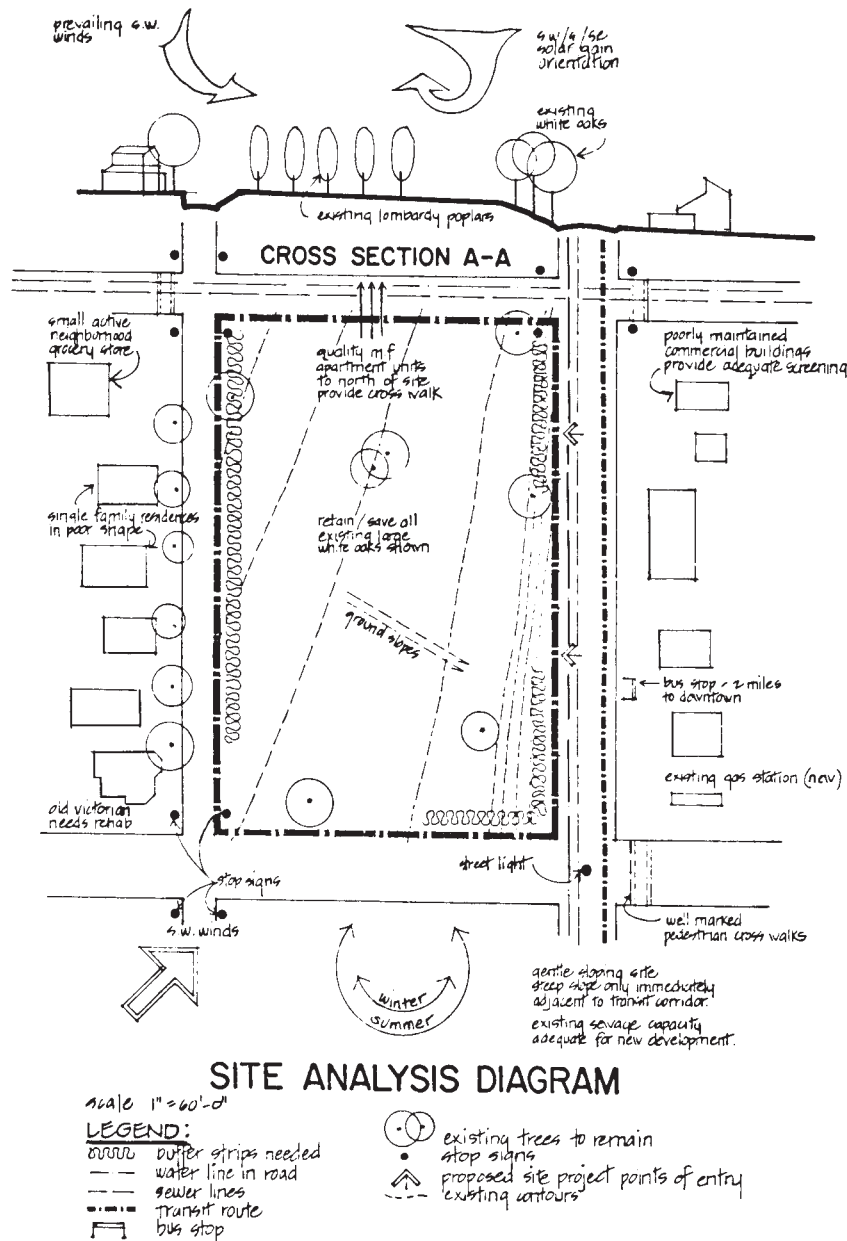


FIGURE 24.55 Site analysis plan. Courtesy Planning Department, Clackamas County, OR

indicates the location and boundaries of individual properties, typically called lots. The term **subdivision** is defined as a tract of land divided into residential lots. The plat required for a minor subdivision can include the following:

- Legal description.
- Name, address, and telephone number of applicant.
- Parcel layout with dimensions.
- Direction of north.
- All existing roads and road widths.
- Number identification of parcels, such as Parcel 1, Parcel 2.
- Location of well or proposed well or name of water district.
- Type of sewage disposal (septic tank or public sanitary sewers). Name of sewer district.
- Zoning designation.
- Size of parcel(s) in square feet or acres.
- Slope of ground (arrows pointing downslope).
- Setbacks of all existing buildings, septic tanks, and drain fields from new property lines.
- All utility and drainage easements.

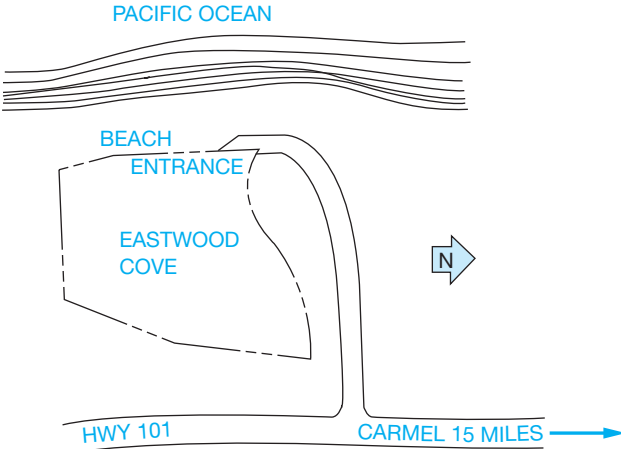


FIGURE 24.56 Vicinity map. © Cengage Learning 2012

- Any natural drainage channels. Indicate direction of flow and whether drainage is seasonal or year-round.
- Map scale.
- Date.
- Building permit application number, if any.

Figure 24.60 shows a typical subdivision of land with three proposed parcels. The local planning agency determines the measurements for a minor or major subdivision.

A major subdivision can require more detailed plats than a minor subdivision. Some of the items that can be included on the plat or in a separate document are the following:

- Name, address, and telephone number of the property owner, applicant, and engineer or surveyor.
- Source of water.
- Method of sewage disposal.

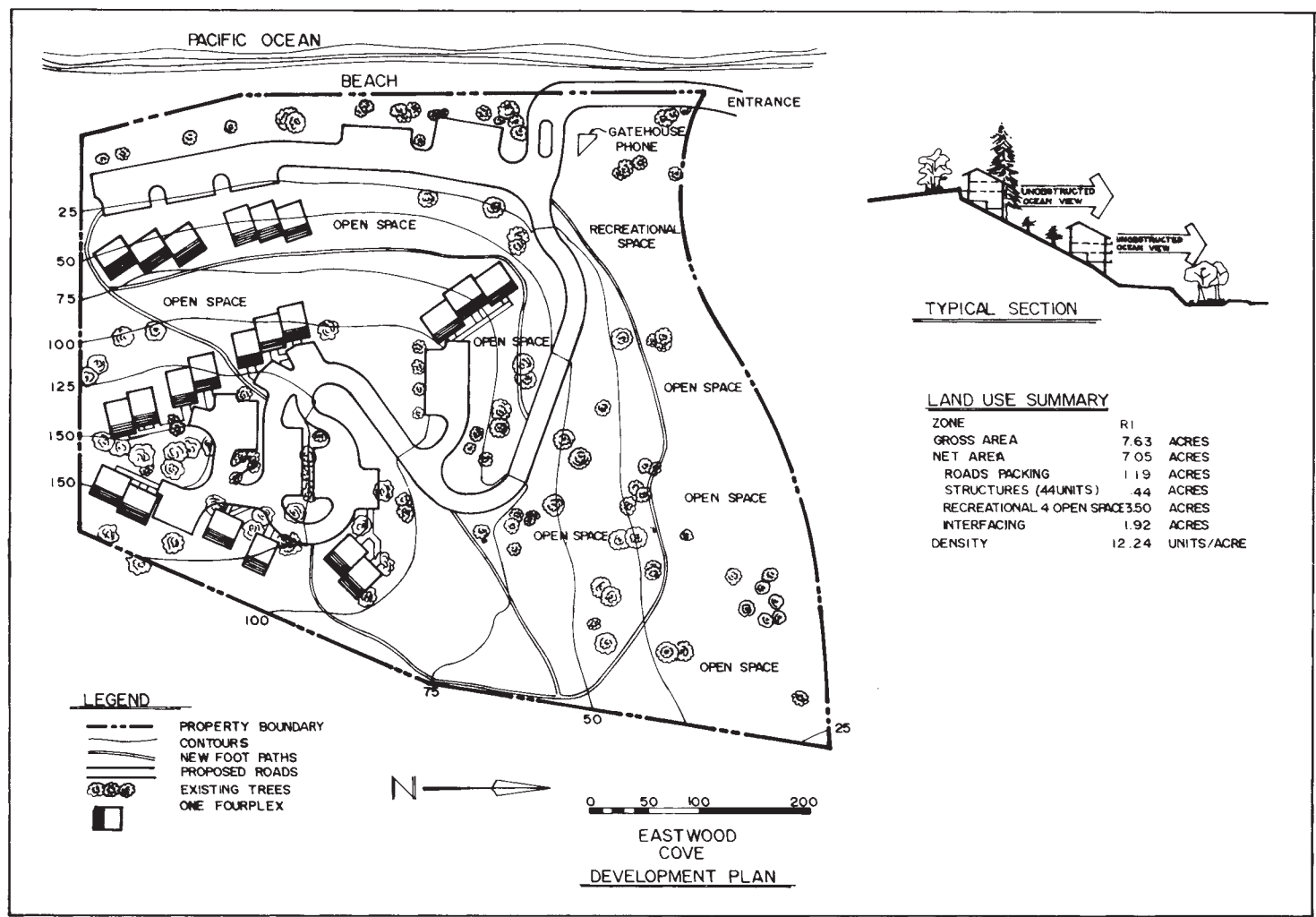


FIGURE 24.57 Planned unit development plan. © Cengage Learning 2012



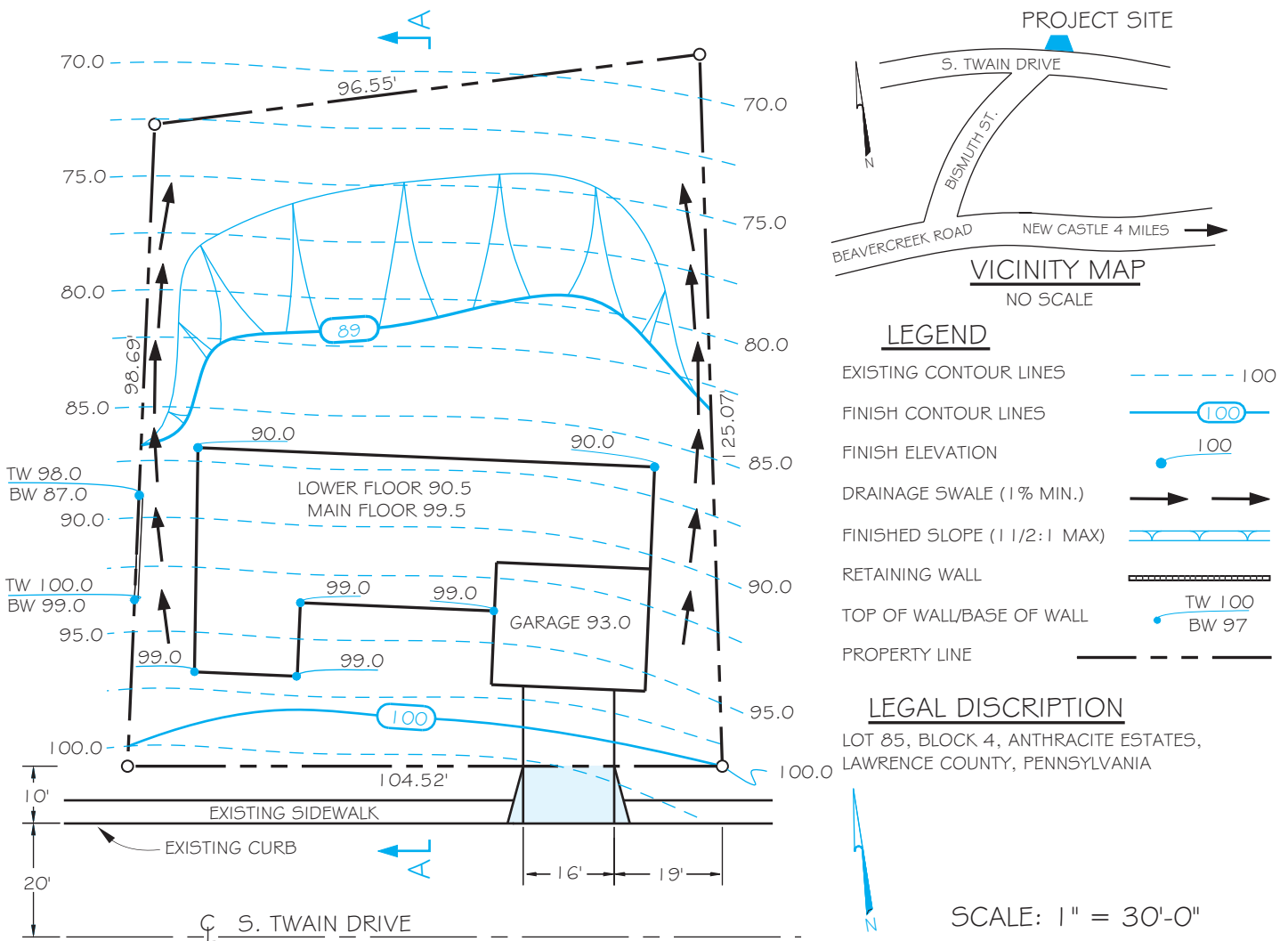
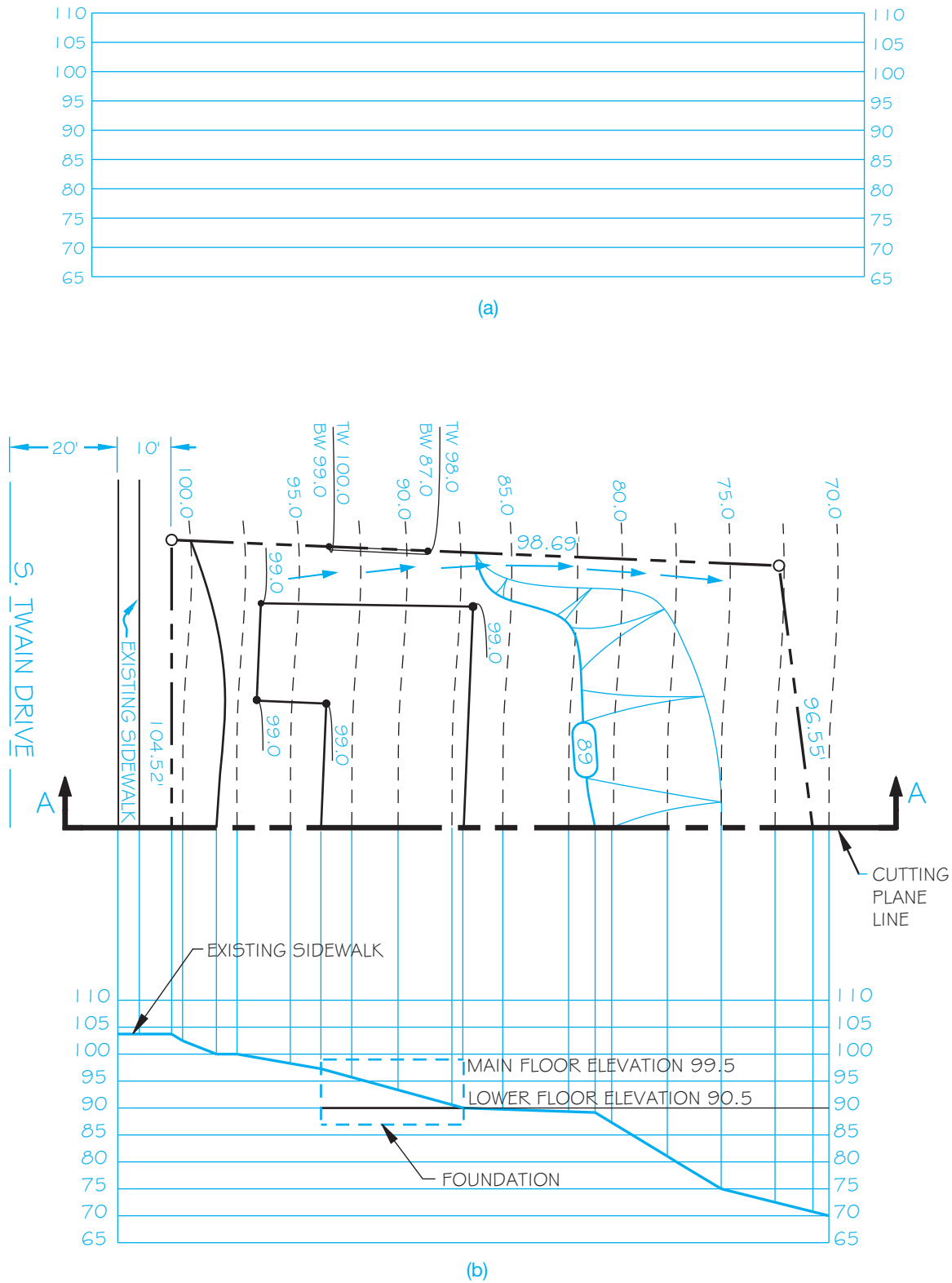


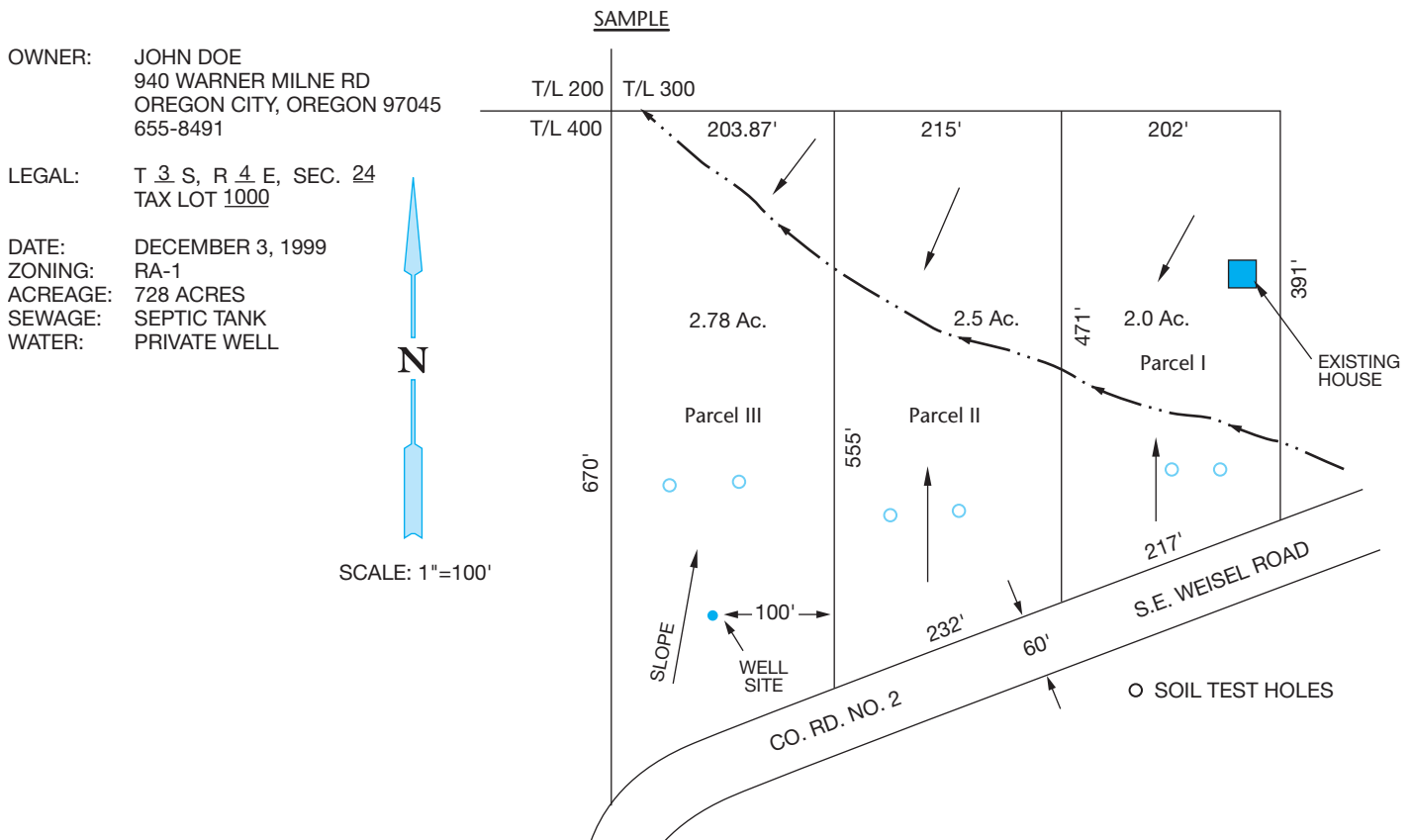
FIGURE 24.58 Grading plan. © Cengage Learning 2012

- Existing zoning.
- Proposed utilities.
- Calculations justifying the proposed density.
- Name of the major partitions or subdivision.
- Date the drawing was made.
- Legal description.
- North arrow.
- Vicinity sketch showing location of the subdivision.
- Identification of each lot or parcel and block by number.
- Gross acreage of property being subdivided or partitioned.
- Dimensions and acreage of each lot or parcel.
- Streets abutting the plat, including name, direction of drainage, and approximate grade.
- Streets proposed, including names, approximate grades, and radius of curves.
- Legal access to subdivision or partition other than public road.
- Contour lines at 2' interval for slopes of 10 percent or less, 5' interval if slopes exceed 10 percent.
- Drainage channels, including width, depth, and direction of flow.
- Locations of existing and proposed easements.
- Location of all existing structures, driveways, and pedestrian walkways.
- All areas to be offered for public dedication.
- Contiguous property under the same ownership, if any.
- Boundaries of restricted areas, if any.
- Significant vegetative areas such as major wooded areas or specimen trees.

Figure 24.61, page 1101, shows an example of a small major subdivision plat.



**FIGURE 24.59** Constructing a profile from the grading plan in Figure 24.58. (a) Establish a horizontal grid with a range of elevations found in the grading plan. (b) Project where each elevation crosses the cutting-plane line perpendicular to the corresponding elevation at the horizontal grid.



## METRICS IN SITE PLANNING

The recommended metric values used in the design and drafting of site plans based on surveying, excavating, paving, and concrete construction are as follows:

	Quantity	Unit and Symbol
Surveying	Length	Meter (m) and kilometer (km)
	Area	Square meter (m <sup>2</sup> ), hectare (ha), and square kilometer (km <sup>2</sup> )
	Plane angle	Degree (°), minute ('), second("), and percent (%)
Excavating	Length	Millimeter (mm) and meter (m)
	Volume	Cubic meter (m <sup>3</sup> )
Paving	Length	Millimeter (mm) and meter (m)
	Volume	Cubic meter (m <sup>3</sup> )
Concrete	Length	Millimeter (mm) and meter (m)
	Area	Square meter (m <sup>2</sup> )
	Volume	Cubic meter (m <sup>3</sup> )

## INTRODUCTION TO SITE PLAN LAYOUT

Site plans can be drawn on media ranging in size from 8 1/2 × 11" up to 34 × 44" (A4 to A0 metric), depending on the purpose of the plan and the guidelines of the local government agency or lending institution requiring the plan. Many local jurisdictions recommend that site plans be drawn on a sheet 8 1/2 × 14" (210 × 360 mm).

Before you begin the site plan layout, there is some important information that you need. This information can often be found in the legal documents for the property, the surveyor's map, the local assessor's office, or the local zoning department. Figure 24.62 is a plat from a surveyor's map that can be used as a guide to prepare the site plan. The scale of the surveyor's plat can vary, although in this case it is 1" = 200' (1:1000 metric). The site plan to be drawn can have a scale ranging from 1" = 10' (1:50 metric) to 1" = 200'. The factors that influence the scale include the following:

- Sheet size.
- Plot size.
- Amount of information required.
- Amount of detail required.

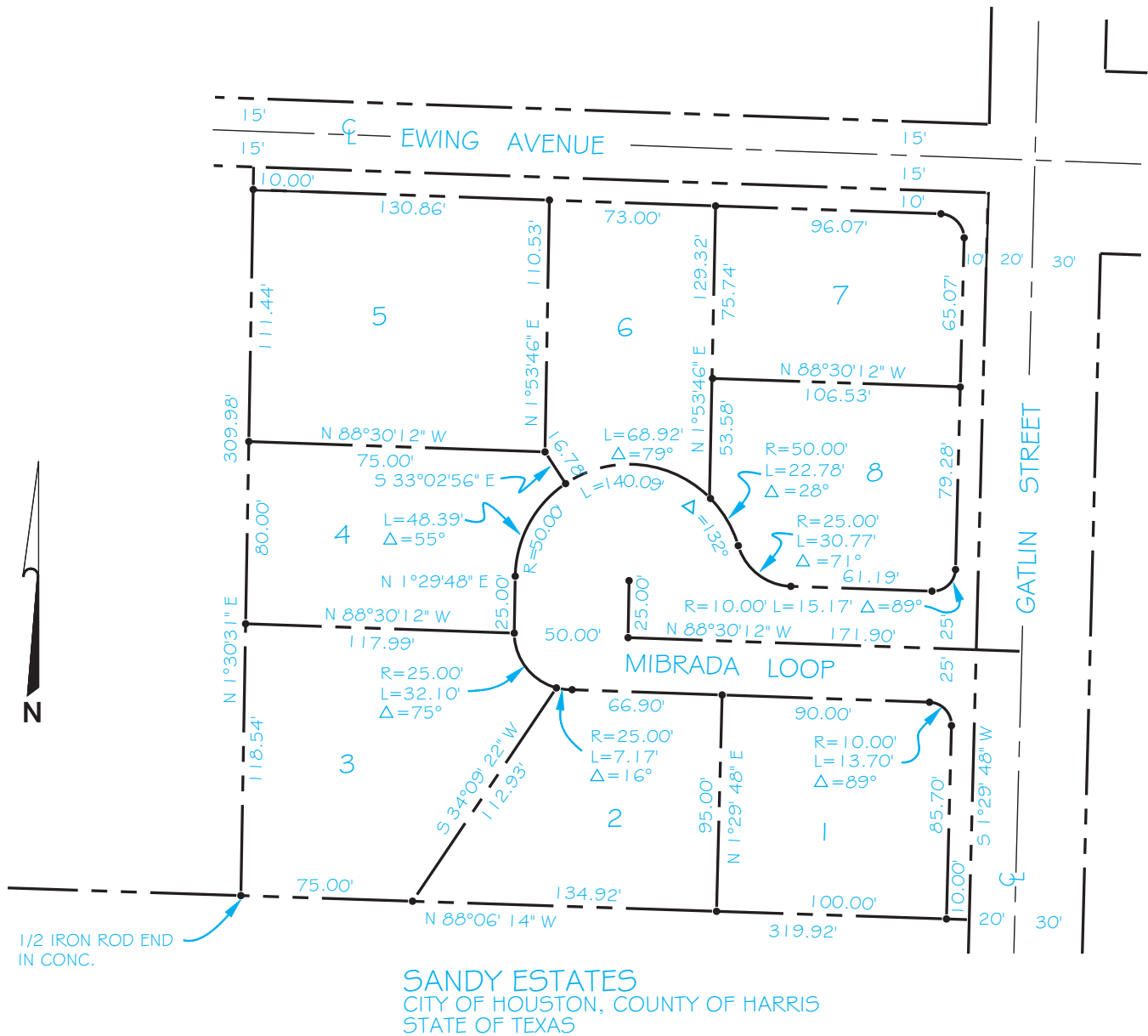


FIGURE 24.61 Small major subdivision plat. © Cengage Learning 2012

Additional information that should be determined before the site plan can be completed usually includes the following:

- Legal description.
- North direction.
- All existing roads, utilities, water, sewage disposal, drainage, and slope of land.
- Zoning information, including front, rear, and side yard setbacks.
- Size of proposed structures.
- Elevations at property corners, driveway at street, or contour elevations.

### SITE DESIGN CONSIDERATIONS

Several issues that can affect the quality of the construction project and adjacent properties should be considered during site design. Some of these factors are outlined as follows:

- Provide a minimum driveway slope of 1/4" per foot. The maximum slope depends on surface conditions and local requirements.
- Provide a minimum lawn slope of 1/4" per foot if possible.
- Single-car driveways should be a minimum of 10' (3 m) wide, and double-car driveways should be a minimum of 18' (5.5 m) wide but can taper to 10' wide at the entrance. Any

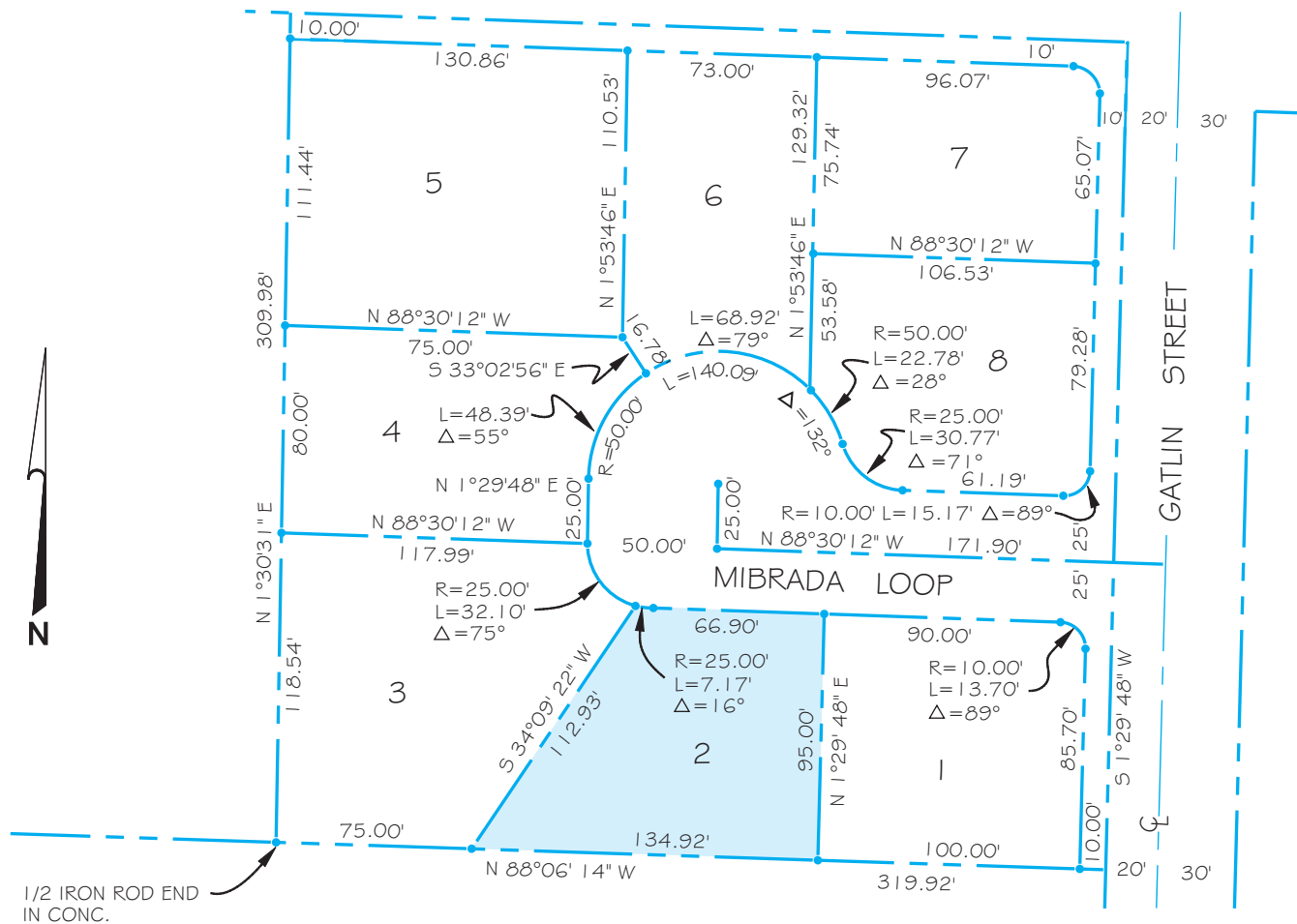


FIGURE 24.62 Plat from a surveyor's map. © Cengage Learning 2012

reduction of driveway width should be centered on the garage door. A turning apron is preferred when space permits. This allows the driver to back into the parking apron and then drive forward into the street, which is safer than backing into the street.

- The minimum turning radius for a driveway should be 15' (4.5 m). The turning radius for small cars can be less, but more should be considered for trucks. A turning radius of 20' (6 m) is preferred if space permits. Figure 24.63 shows a variety of driveway layouts for you to use as examples. The dimensions are given as commonly recommended minimums for small to standard-sized cars. Additional room should be provided if available.
- Provide adequate room for the installation of and future access to water, sewer, and electrical utilities.
- Do not build over established easements. An easement is the right-of-way for access to property and for the purpose of construction and maintenance of utilities.
- Follow basic grading rules, which include not grading on adjacent property. Do not slope the site so as to cause water

drainage onto adjacent property. Slope the site away from the house. Adequate drainage of at least 10' away from the house is recommended.

- Identify all trees that are to remain on the site after construction.
- Establish retaining walls where needed to minimize the slope, control erosion, and level portions of the site.

### Rural Residential Fire Department Access and Site Planning

Special considerations should be made when designing driveways and turnarounds in rural areas. In urban and suburban areas, fire truck access is normally designed into the subdivision plan and each residence is fairly easy to access for firefighting purposes. Rural locations pose special problems for firefighting because they are often larger pieces of property that frequently have long gravel driveways where access can be limited. Check the regulations for your location. The guidelines

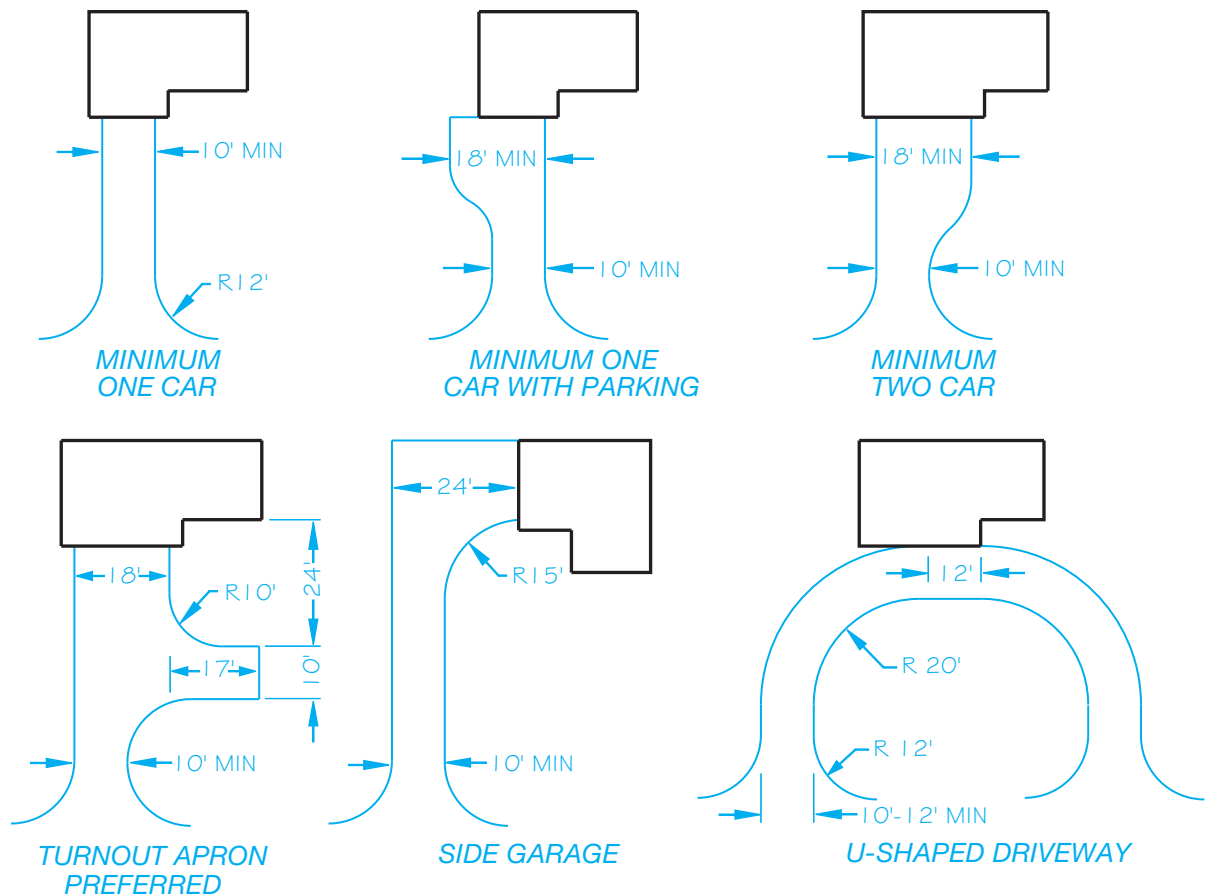


FIGURE 24.63 Typical driveway layout options. © Cengage Learning 2012

governing the site design can differ from one location to the next, but the following are common standards:

- **Road clearances:** A 15' minimum width all-weather surface driveway must be provided, with an additional 5' width clear of vegetation. The driveway must also be clear of vegetation to a height of 13'-6". **All-weather** means gravel or paved surface. Figure 24.64 shows several basic driveway design options.
- **Road load capacities:** The driveway must be engineered for a 12,500 lb wheel load and 50,000 lb gross vehicle load.
- **Grade:** A 10 percent average minimum road grade is preferred, but up to 15 percent for 200' is acceptable.
- **Dead ends:** Provide a turnaround if the driveway is longer than 150'.
- **Turnouts:** Provide a 20' wide by 40' long passage space at the midpoint of every 400' length.
- **Bridges and culverts:** These features must be designed to support a minimum of 50,000 lb.
- **Fire safety zone:** Provide a firebreak at least 30' around all structures. A **firebreak** requires ground cover no more than 25" in height and all dead vegetation removed. Steep terrain around the structure can require a greater firebreak.
- **Property identification:** The property address shall be posted on a fire department–approved sign where the driveway meets the main road.
- **Firefighting water supply:** On-site water supplies, such as a swimming pool, pond, or water-storage tank, must be accessible within 15'. A fire-sprinkler system designed and installed in the home can be substituted for a water supply.
- **Roof coverings in wildfire zones:** **Wildfire zones** are heavily wooded areas. The use of wood roofing material or other combustible materials is restricted in these areas.

## LAYING OUT PROPERTY LINES

Earlier in this chapter, you were introduced to the methods for describing properties. Look at Figure 24.62 and notice that the property lines of each lot and the boundaries of the plat are labeled with distances and bearings. An example is the west property line of lot 2, which is 112.93' for the length and S34°09'22" W for the bearing. This property line is set up to be drawn as shown

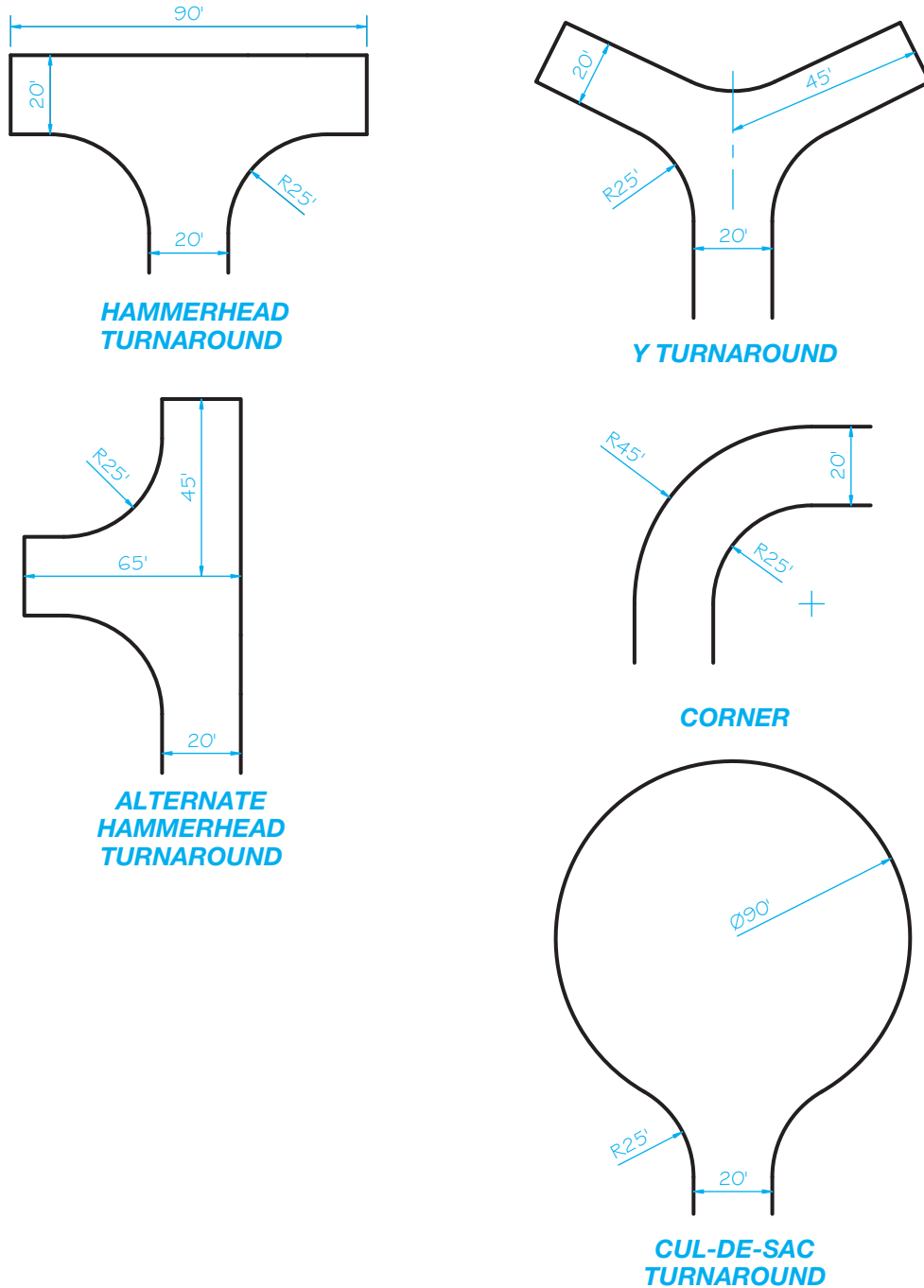


FIGURE 24.64 Driveway turnaround options for rural residential fire department access.

in Figure 24.65a. After the property lines are drawn, they are labeled with the distance and bearing, as shown in Figure 24.65b.

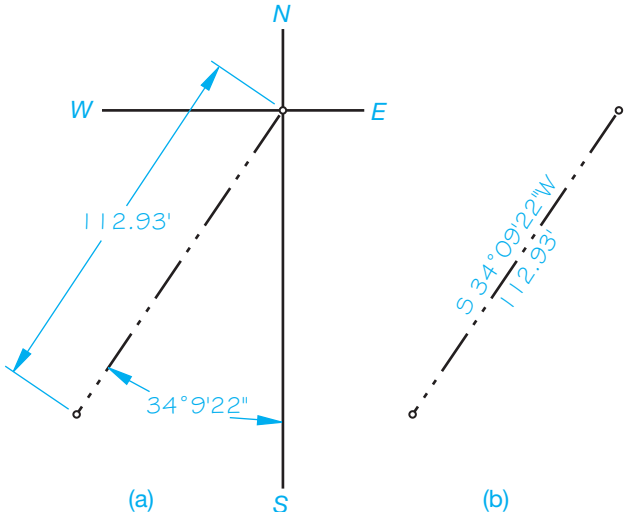
Many plats have property lines that curve, such as the lines around the cul-de-sac in Figure 24.62. For example, the largest curve is labeled  $R = 50.00'$   $L = 140.09'$ .  $R$  is the radius of the curve, and  $L$  is the length of the curve. There are three sub-lengths in this curve.  $L = 48.39'$  is for lot 4,  $L = 68.92'$  is for lot 6, and  $L = 22.78'$  is for lot 8. Figure 24.66a shows the setup for drawing this curve using the radius and arc lengths. Plats also typically show a delta angle for curves, which is represented

by the symbol  $\Delta$ . The delta angle is the included angle of the curve. The **included angle** is the angle formed between the center and the end points of the arc, as shown in Figure 24.66b. Figure 24.66c shows the final labeling of the curve.

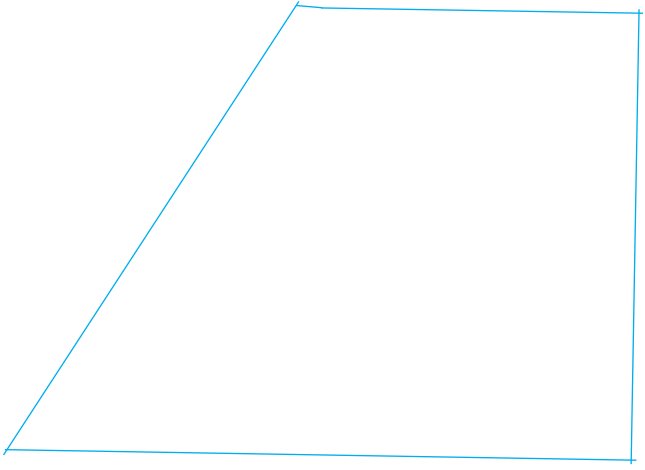
### Steps in Site Plan Layout

Follow these steps to draw a site plan.

- STEP 1** Select the paper size. In this case, the size is  $8 \frac{1}{2} \times 11"$  (A4 metric). Evaluate the plot to be drawn. Lot 2



**FIGURE 24.65** Drawing and labeling a property line. (a) Using known values to draw the property line. (b) The finished property line drawn with the bearing displayed on one side and the length on the other side.



**FIGURE 24.67** Step 2: Lay out the plot plan property lines.

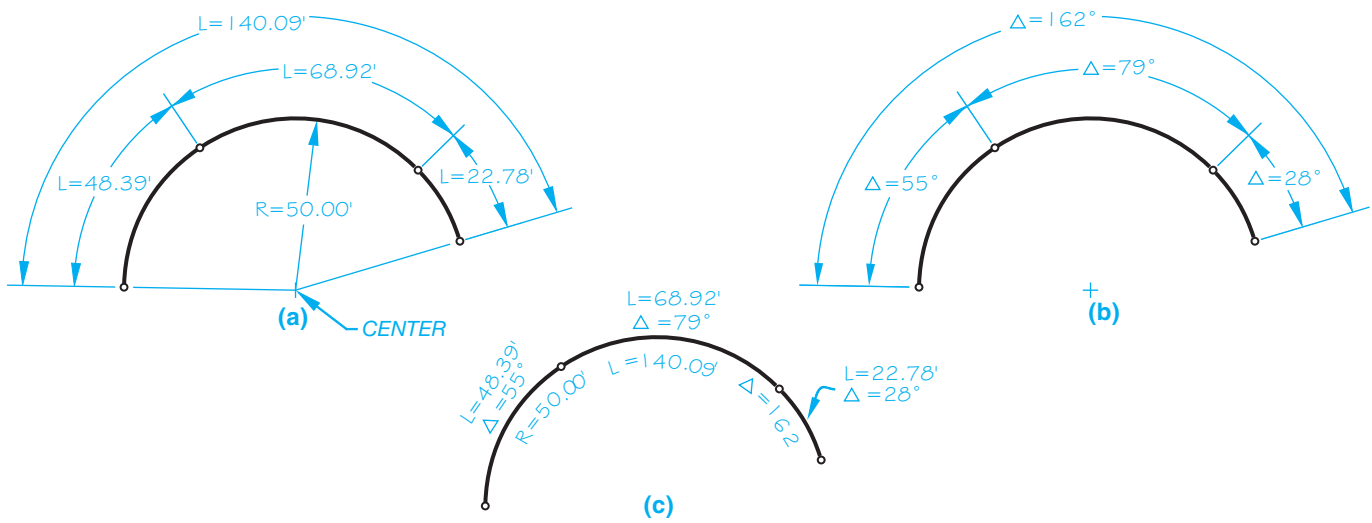
of Sandy Estates, shown in Figure 24.62, is used. Determine the scale to use by considering how the longest dimension (134.92') fits on the sheet. Always try to leave at least a 1/2" (12 mm) margin around the sheet.

**STEP 2** Use the given plat as an example to lay out the proposed site plan. If a plat is not available, then the site plan can be laid out from the legal description by establishing the boundaries using the bearings and dimensions in feet. Lay out the entire site plan using construction lines. If errors are made, the construction lines are very easy to erase or CADD layers can be used (see Figure 24.67).

**STEP 3** Lay out the proposed structure using construction lines. The proposed structure in this example is 60' long and 36' wide. The house can be drawn on the

site plan with or without showing the roof. A common practice is to draw only the outline of the floor plan. In some cases, the roof overhang is considered in the setback. In these situations, the house outline is drawn as a dashed line under the roof and dimensions are given for the house and the overhang. The front setback is 25', and the east side is 15'. Lay out all roads, driveways, walks, and utilities. Be sure the structure is inside or on the minimum setback requirements. **Setbacks** are imaginary boundaries beyond which the structure may not be placed. Think of them as property line offsets that are established by local regulations. Minimum setbacks can be confirmed with local zoning regulations. The minimum setbacks for this property are 25' front, 10' sides, and 35' back from the property lines to the house (see Figure 24.68).

**STEP 4** Darken all property lines, structures, roads, driveways, walks, and utilities, as shown in Figure 24.69. Some drafters use a thick line or shading for the structure.

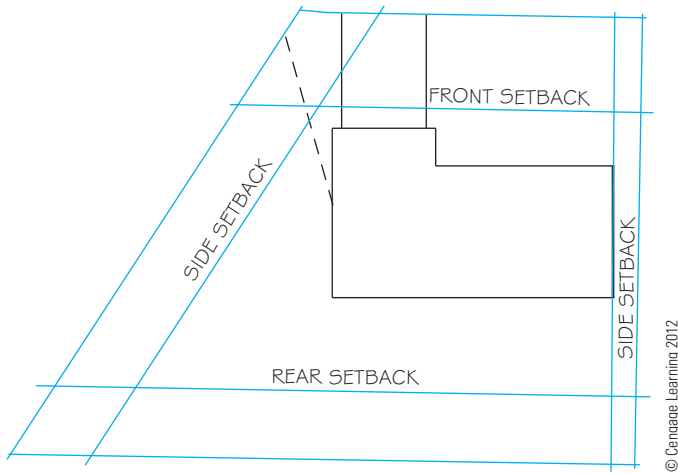


**FIGURE 24.66** Drawing and labeling curved property lines. (a) Arc length dimensions. (b) Included angle dimensions. (c) The arc property line labeled.



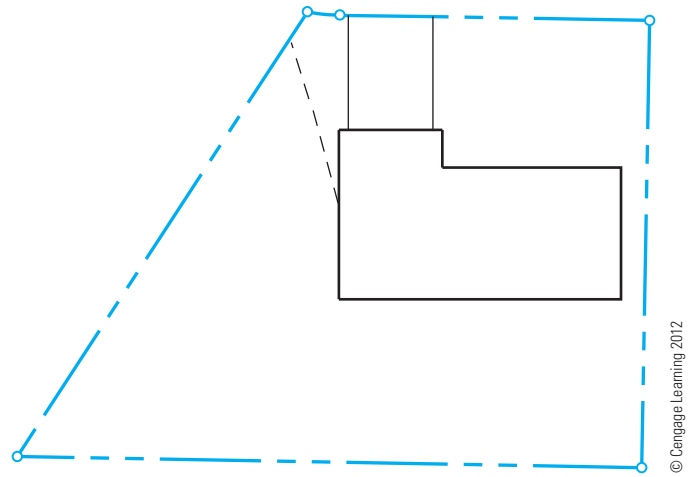
Generally, the plat or legal description provides metes and bounds coordinates for property line boundaries. For example, the south property line for lot 2 has the coordinates given with the bearing and distance of N88°06'14"W and 134.92'. CADD systems that are used for either general or architectural applications have a surveyor's units setting. When the CADD system is set to draw lines based on surveyor's units, the south property line of lot 2 is drawn with this computer prompt: @134.92' < N88d06' 14"W. Notice that the degree symbol (°) is replaced with the lower-case letter *d* when entering a bearing at the computer prompt.

Most CADD programs have options for drawing lines that allow you to create the curves in Figure 24.66. The commands typically allow you to draw arcs with a combination of radius, arc length, and included angle. This provides you with the flexibility needed to use the R, L, and Δ information provided on the plat or in the surveyor's notes.



**FIGURE 24.68** Step 3: Lay out the structures, roads, driveways, walks, and utilities. Be sure the structure is on or within the minimum required setbacks.

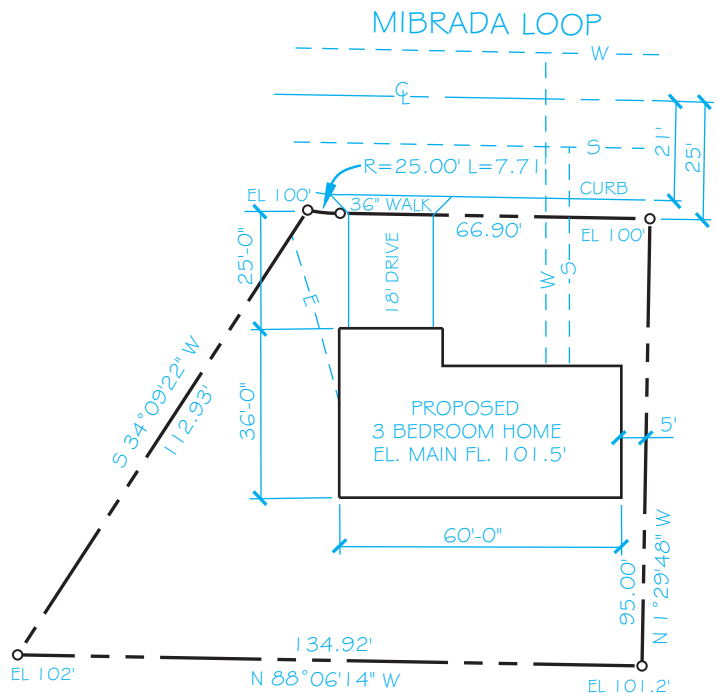
**STEP 5** Add dimensions and contour lines (if any) or elevations. The property line dimensions are generally placed on the inside of the line in decimal feet, and the bearing is placed on the outside of the line. The dimensions locating and giving the size of the structure are commonly in feet and inches or in decimal feet. Try to keep the amount of extension and dimension lines to a minimum on the site plan. One way



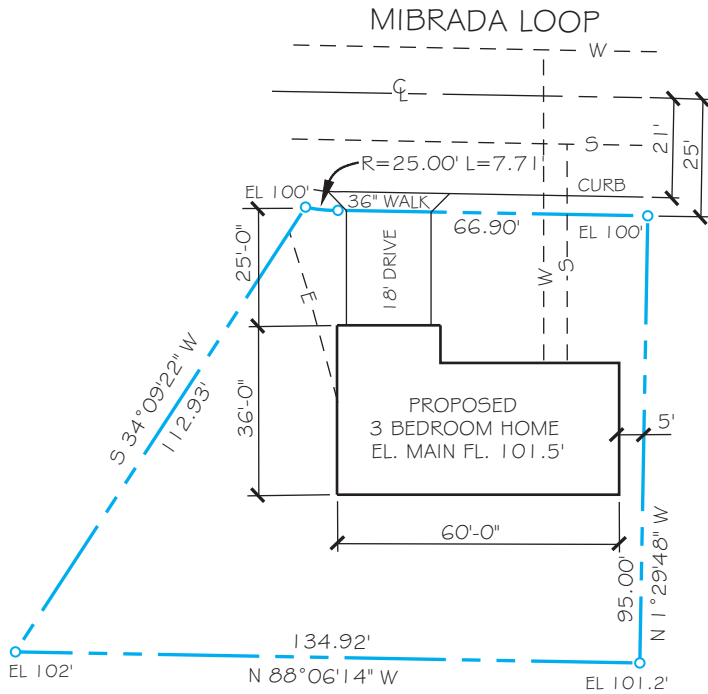
**FIGURE 24.69** Step 4: Darken boundary lines, structures, roads, driveways, walks, and utilities.

to do this is to dimension directly to the house and place size dimensions inside the house outline. Add all labels, including the road name, property dimensions and bearings (if used), utility names, walks, and driveways, as shown in Figure 24.70.

**STEP 6** Complete the site plan by adding the north arrow, the legal description, title, scale, client's name, and other title block information. Figure 24.71 shows the complete site plan.



**FIGURE 24.70** Step 5: Add dimensions and elevations and then label all roads, driveways, walks, and utilities. © Cengage Learning 2012



**PLOT PLAN**

SCALE 1"=20'

LEGAL:  
 LOT 2 SANDY ESTATES  
 CITY OF HOUSTON,  
 COUNTY OF HARRIS,  
 STATE OF TEXAS



**FIGURE 24.71** Step 6: Complete the plot plan. Add title, scale, north arrow, legal description, and other necessary information, such as the owner's name if required. © Cengage Learning 2012

**Site Plan Drawing Checklist**

Check off the items in the following list as you work on the basic site plan to be sure that you have included all of the necessary details. Site plans for special applications may require additional information. Refer to this chapter for features found in special plans such as grading plan, subdivision plan, site analysis plan, planned unit development, and commercial plan.

- Site plan title and scale.
- Property legal description.
- Property line dimensions and bearings.
- North arrow.
- Existing and proposed roads with the elevation at the center of roads.
- Driveways, patios, decks, walks, and parking areas.
- Existing and proposed structures with floor-level elevations.
- Public or private water supplies.
- Public or private sewage disposal.
- Location of utilities.

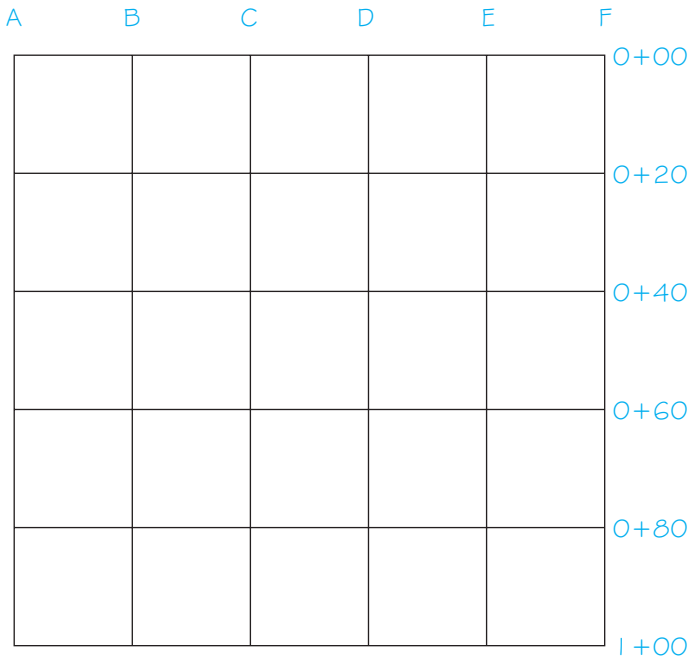
- Rain and footing drains and storm sewer or drainage.
- Topography, including contour lines or elevations at property corners, street centerline, driveways, and floor elevations.
- Front, side, and rear setbacks dimensioned and in compliance with zoning.
- Specific items on adjacent properties, if required, such as existing structures, water supply, sewage disposal, trees, or water features.
- Existing and proposed trees may be required.

**DRAWING CONTOUR LINES**

Contour lines represent intervals of equal elevation, as explained earlier in this chapter. The following discussion shows you how to lay out contour lines on a construction site. Surveyors can use various methods to establish elevations at points on the ground. This information is recorded in field notes. You then use the field notes to plot the contour lines. This discussion explains the grid survey method. Another common technique is the control point survey, which establishes elevations that are recorded on a map. You then lay out the elevations for the contour lines based on the given elevation points. The radial survey is also a common method used for locating property corners, structures, natural features, and elevation points. This system establishes control points using a process called radiation in which measurements are taken from a survey instrument located at a base known as a transit station. From the transit station, a series of angular and distance measurements are established to specific points on the ground. You then establish the property lines, land features, and contours based on these points.

**Using the Grid Survey to Draw Contour Lines**

A grid survey divides the site into a pattern similar to a checkboard. Stakes are driven into the ground at each grid intersection. The surveyor then establishes an elevation at each stake and records this information in field notes. The spacing of the stakes depends on the land area and the topography. The stakes may be placed in a grid 10, 20, 50, or 100' apart, for example. An example is shown in Figure 24.72. This grid has lines spaced 20' apart. The vertical lines are labeled with letters, and the horizontal lines are labeled with numbers that are called stations. The station numbers are in two parts: for example, 0 20. The first number is hundreds of feet. Zero represents 0 hundreds, or 0'. The first number is followed by a plus (+) sign. This means that you add the first number to the second number to get the actual distance to this station. The second number is in tens of feet; for example, 0' + 20' or 1' + 20' = 120'. The intersection of vertical line B and station 0 + 40 is identified as station B-0 + 40. The field notes record the elevation at each station, as shown in Table 24.1; for example, the elevation at A-0 + 80 is 105'.



**FIGURE 24.72** Step 1: Draw a grid at a desired scale. Label the vertical lines with letters and the horizontal lines with station numbers, as shown in this example. © Cengage Learning 2012

### Steps in Drawing Contour Lines

Contour lines are drawn from grid survey field notes using the following steps:

TABLE 24.1 GRID SURVEY FIELD NOTES			
Station	Elevation	Station	Elevation
A-0 + 00	101	D-0 + 00	95
A-0 + 20	104	D-0 + 20	97
A-0 + 40	108	D-0 + 40	99
A-0 + 60	112	D-0 + 60	105
A-0 + 80	105	D-0 + 80	100
A-1 + 00	102	D-1 + 00	94
B-0 + 00	100	E-0 + 00	94
B-0 + 20	102	E-0 + 20	96
B-0 + 40	105	E-0 + 40	98
B-0 + 60	110	E-0 + 60	100
B-0 + 80	104	E-0 + 80	95
B-1 + 00	100	E-1 + 00	92
C-0 + 00	98	F-0 + 00	92
C-0 + 20	100	F-0 + 20	93
C-0 + 40	102	F-0 + 40	95
C-0 + 60	108	F-0 + 60	98
C-0 + 80	102	F-0 + 80	90
C-1 + 00	95	F-1 + 00	85

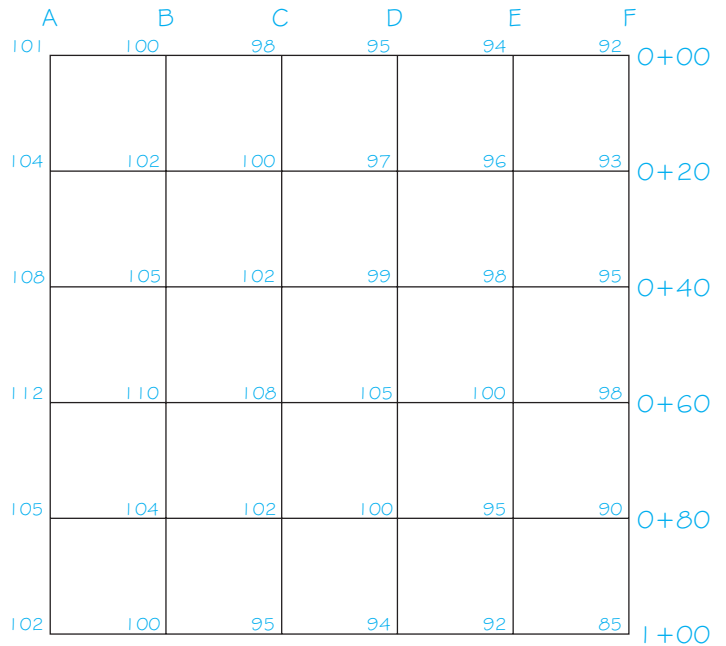
**STEP 1** Draw a grid at a desired scale similar to Figure 24.72. Use construction lines if you are drafting manually or establish a GRID or CONSTRUCTION layer if you are using CADD. Label the vertical and horizontal grid lines.

**STEP 2** Use the field notes to label the elevation at each grid intersection. The elevations, labeled on the grid in Figure 24.73, are based on the field notes found in Table 24.1.

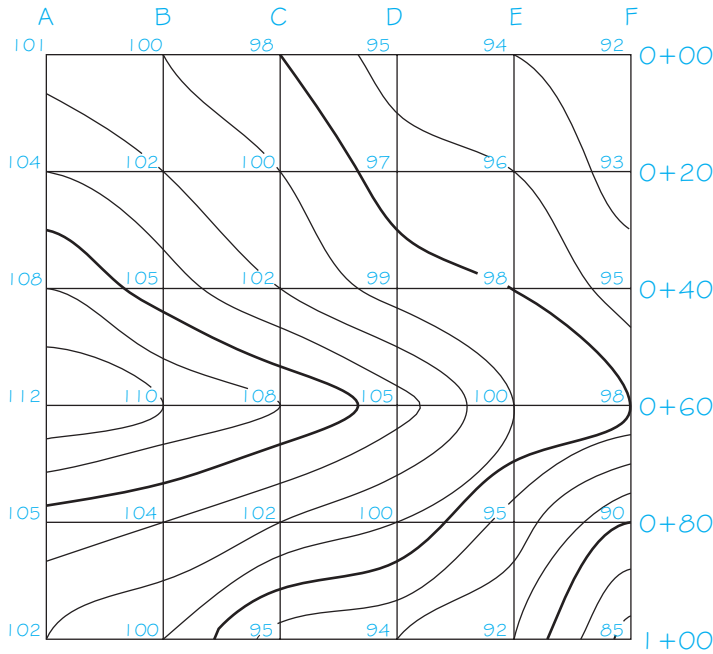
**STEP 3** Determine the desired contour interval and connect the points on the grid that represent contour lines at this interval. The contour interval for the grid in Figure 24.73 is 2'. This means that you will establish contour lines every 2', such as at 92, 94, 96, and 98'.

**STEP 4** Establish the contour lines at the desired contour interval by picking points on the grid that represent the desired elevations. If a grid intersection elevation is 100, then this is the exact point for the 100' elevation on the contour line. If the elevation at one grid intersection is 98' and the next is 102', then you estimate the location of 100' between the two points. This establishes another 100' elevation point.

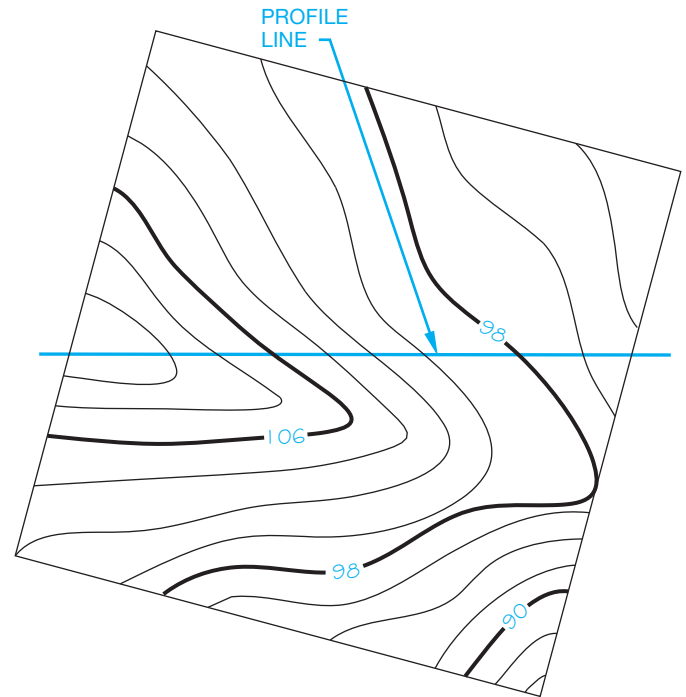
**STEP 5** When you have identified the points for all of the 100' elevations, then connect the points to create the contour line. See Figure 24.74. Do this for the elevation at each contour interval.



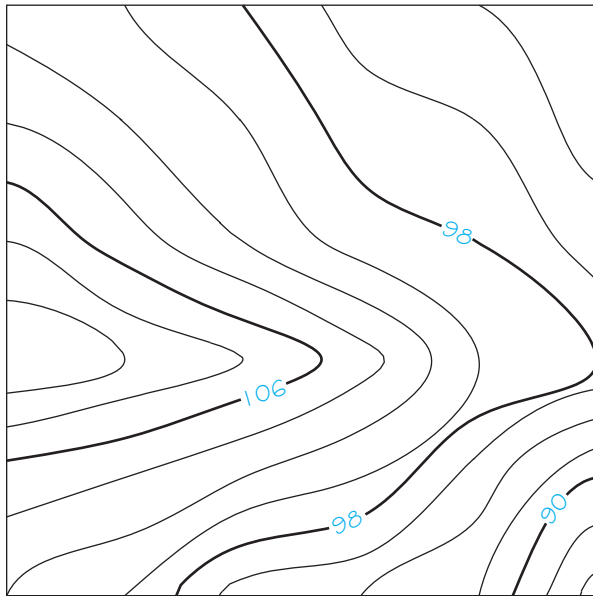
**FIGURE 24.73** Steps 2 and 3: Use the field notes in Table 24.1 to label the elevation at each grid intersection. © Cengage Learning 2012



**FIGURE 24.74** Step 5: Connect the points at the elevations for each contour interval. © Cengage Learning 2012



**FIGURE 24.76** Step 1: Draw a straight line on the contour map at the location of the desired profile. © Cengage Learning 2012



© Cengage Learning 2012

**FIGURE 24.75** Darken the contour lines. The intermediate lines are thin, and the index contour lines are broken and labeled with the elevation of the contour line.

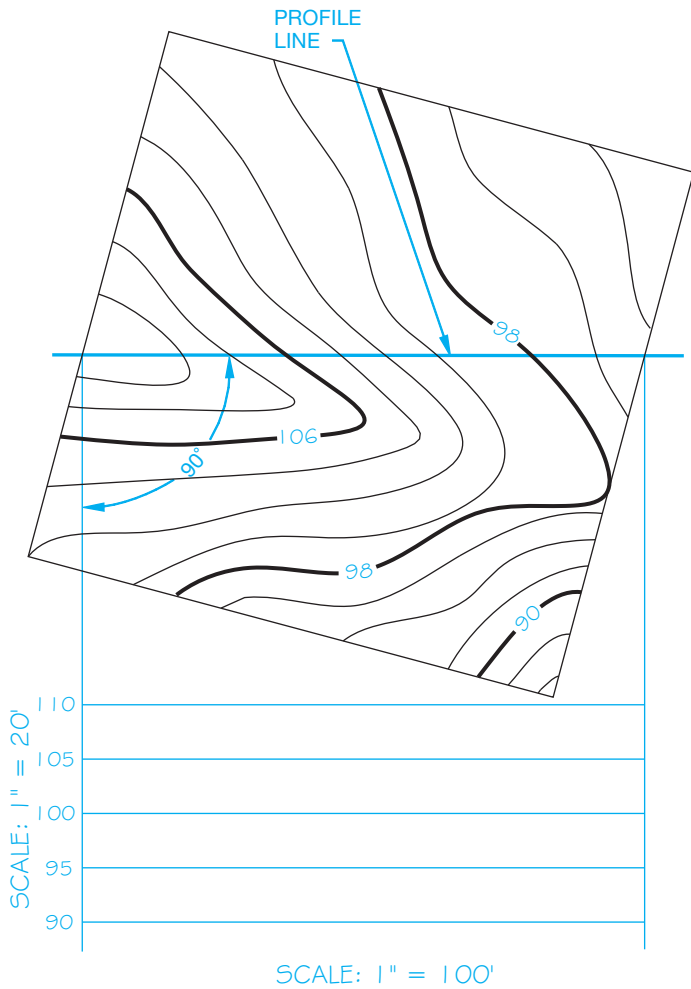
**STEP 6** Darken the contour lines. The intermediate lines are thin. The index contour lines are broken and labeled with the elevation and are generally drawn thicker than intermediate lines, as shown in Figure 24.75.

## DRAWING SITE PROFILES

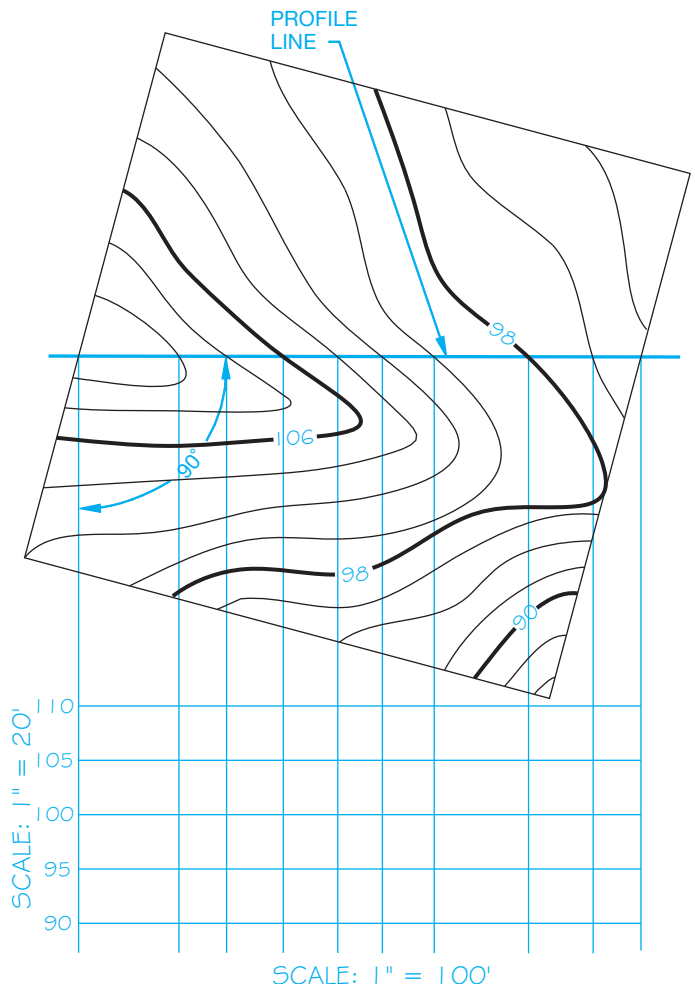
As described earlier, a profile is a vertical section of the surface of the ground or of underlying earth that is taken along any desired fixed line. The profile of a construction site is usually through the building excavation location, but more than one profile can be drawn as needed. The profile for road construction is normally placed along the centerline. Profiles are drawn from the contour lines at the section location. The contour map and its related profile are commonly referred to as the **plan and profile**. Profiles have uses such as showing road grades and site excavation. Projecting directly from the desired cut location on the contour map following these steps creates the profile:

**STEP 1** Draw a straight line on the contour map at the location of the desired profile (see Figure 24.76).

**STEP 2** Set up the profile vertical scale. The horizontal scale is the same as the map, because you are projecting directly from the map. The vertical scale can be the same or it can be exaggerated. Exaggerated vertical scales are used to give a clearer representation of the contour when needed. Establish a vertical scale increment that is above the maximum elevation and one that is below the minimum elevation. Figure 24.77 shows how the vertical scale is set up. Notice that the profile is projected 90° from the profile line on the map.



**FIGURE 24.77** Step 2: Project the profile 90° from the start of the profile line. Set up the vertical scale. Label the vertical scale and the elevation of each contour along the vertical scale. Draw a horizontal line at each contour interval. Label the horizontal scale. © Cengage Learning 2012



**FIGURE 24.78** Step 3: Project a line 90° from the location where every contour line crosses the profile line. © Cengage Learning 2012

**STEP 3** Project a line from the location where every contour line crosses the profile line on the contour map (see Figure 24.78).

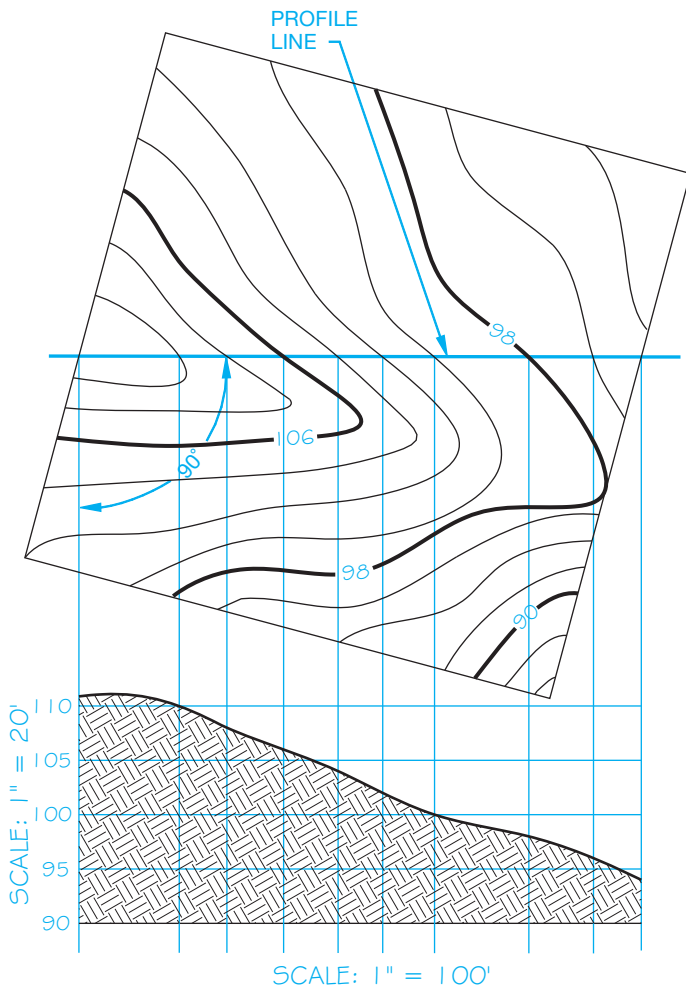
**STEP 4** Draw the profile by connecting the points where every two vertical and horizontal lines of the same elevation intersect, as shown in Figure 24.79.

## DRAWING THE GRADING PLAN

If you have a specific location on a site where a level excavation must take place for the proposed construction, you can lay out a grading plan. The **grading plan** shows the elevation of the site after excavation. This plan shows where areas need to be cut and filled. This is referred to as **cut and fill** as previously discussed. Figure 24.80 shows the site plan location for the desired level excavation. The following steps

can be used to draw the grading plan for a level construction site:

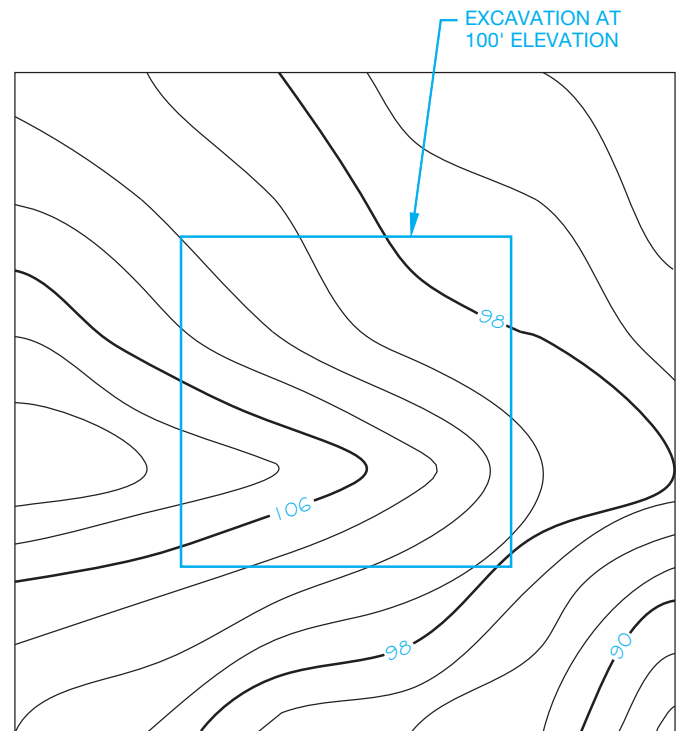
**STEP 1** Determine the angle of repose, which is the slopes of cut and fill from the excavation site measured in feet of horizontal run to feet of vertical rise. One unit of rise to one unit of run is specified as 1:1 (see Figure 24.81). The actual angle of repose for cuts and fills is normally determined by approved soils engineering or engineering geology reports. The slope of cut surfaces can be no steeper than is safe for the intended use and cannot exceed one unit vertical in two units horizontal (1:2). Alternative designs may be allowed if soils engineering or engineering geology reports state that the site has been investigated and give an opinion that a cut at a steeper slope will be stable and not create a hazard to property. Fill slopes cannot be constructed on natural slopes steeper than one unit vertical in two units



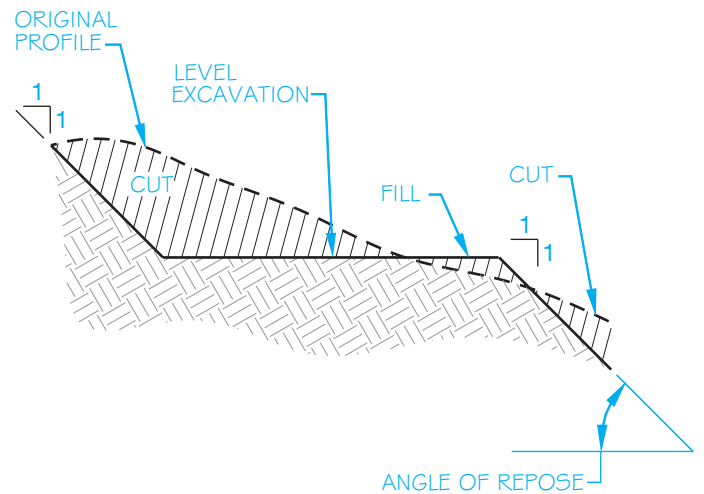
**FIGURE 24.79** Step 4: Draw the profile by connecting the points where every two vertical and horizontal lines of the same elevation intersect. © Cengage Learning 2012

horizontal (1:2). The ground surface must be prepared to receive fill by removing vegetation, unstable fill material, topsoil, and other unsuitable materials to provide a bond with the new fill. Other requirements include soil engineering where stability, steeper slopes, and heights are issues. Soil engineering can require benching the fill into sound material and specific drainage and construction methods. A **bench** is a fairly level step excavated into the earth material on which fill is placed.

**STEP 2** Draw parallel lines around the excavation site, with each line representing the elevation at the cut and fill. If the angle of repose is 1:1 and the contour interval is 2', then these parallel lines are 2' from the level excavation site. The contour interval is determined by multiplying rise by contour interval ( $1 \times 2 = 2$  in this example) (see Figure 24.82).



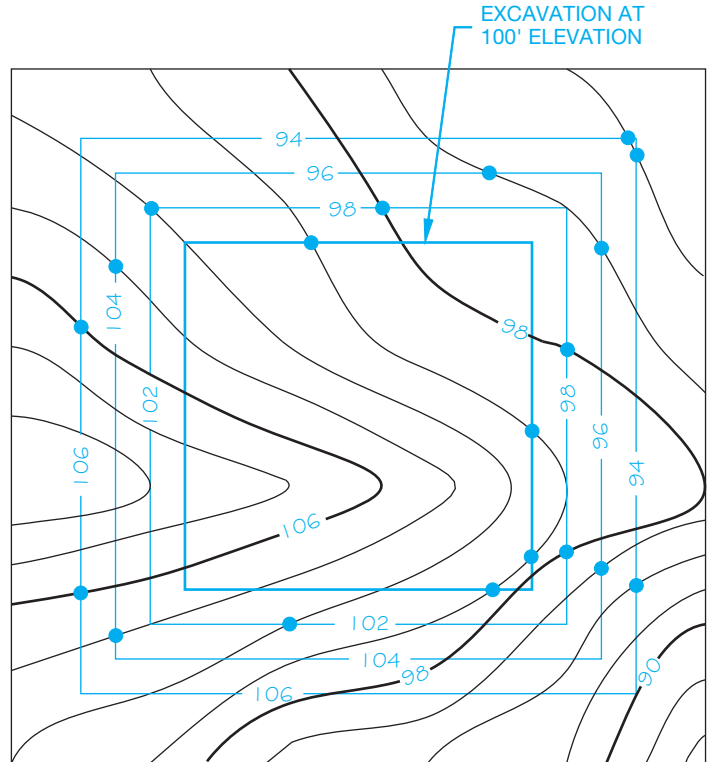
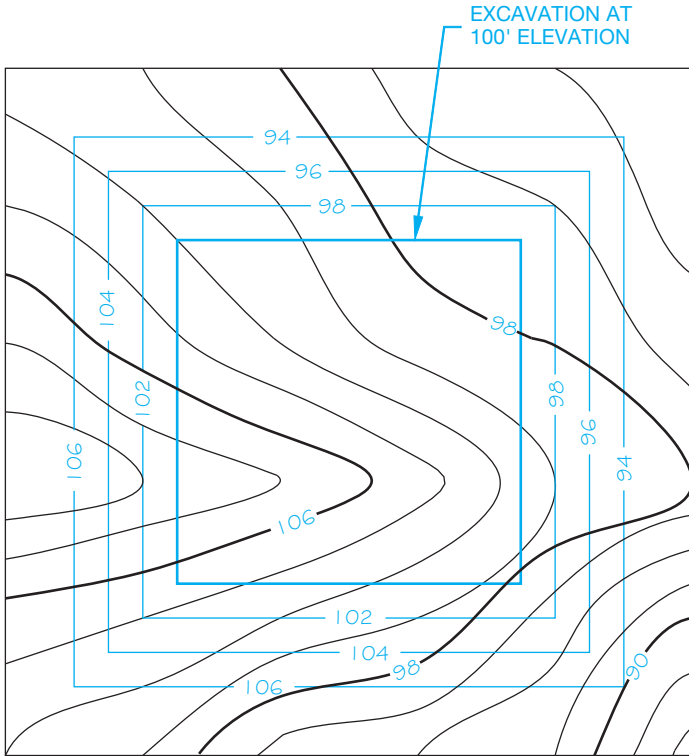
**FIGURE 24.80** Site plan location for the desired level excavation at 100'. © Cengage Learning 2012



**FIGURE 24.81** Step 1: Angle of repose. © Cengage Learning 2012

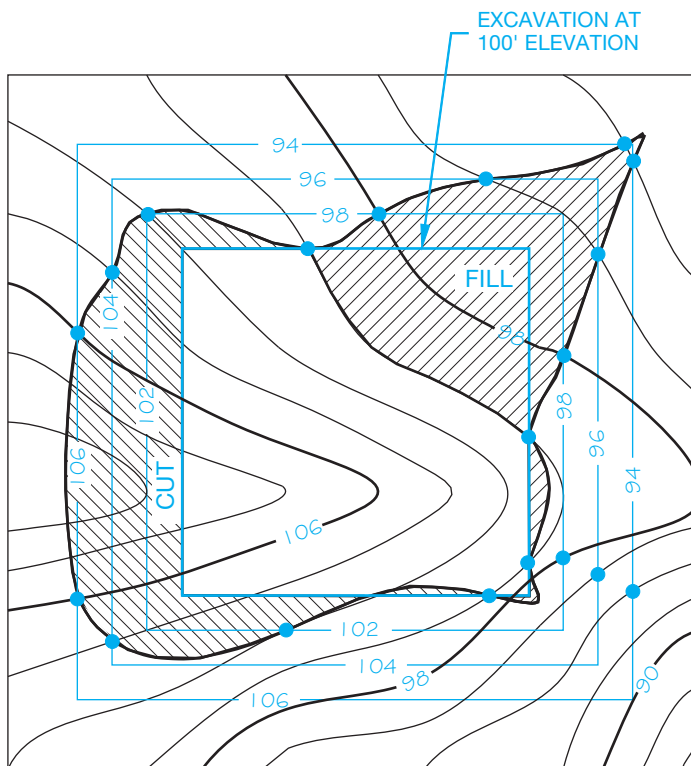
**STEP 3** The elevation of the excavation is 100'. Elevations above this are considered cuts, and elevations below this are fills. To establish the cut and fills, mark where the elevations of the parallel lines around the excavation match the corresponding elevations of the contour lines, as shown in Figure 24.83.

**STEP 4** Connect the points established in Step 3, as shown in Figure 24.84. The cut and fill areas can be shaded or left unshaded.



**FIGURE 24.82** Step 2: Draw parallel lines around the excavation site, with each line representing the elevation of the cut and fill. © Cengage Learning 2012

**FIGURE 24.83** Step 3: To establish the cut and fill, mark where the elevations of the parallel lines around the excavation match the corresponding elevations of the contour lines. © Cengage Learning 2012



**FIGURE 24.84** Step 4: Complete the cut and fill drawing by connecting the points. The cut and fill areas can be labeled, and they can be shaded or left unshaded.

© Cengage Learning 2012

### USING CADD TO DRAW SITE PLANS

There are CADD software packages that can be customized to assist in drawing site plans. Also available are complete CADD mapping packages that allow you to draw topographic maps, terrain models, grading plans, and land profiles. It all depends on the nature of your business and how much power you need in the CADD mapping program. One of the benefits of CADD over manual drafting is accuracy. For example, you can draw a property boundary line by giving the length and bearing. The computer automatically draws the line and then labels the length and bearing. Continue by entering information from the surveyor's

notes to draw the entire property boundary in just a few minutes. Such features increase the speed and accuracy of drawing site plans. A residential site plan drawn using CADD mapping software is shown in Figure 24.85.

The needs of the commercial site plan are a little different from the residential requirements. The commercial CADD site plan package uses the same features as the residential application and also has the ability to design street and parking lot layouts. The commercial CADD drafter uses features from symbol libraries, including utility symbols; street, curb, and gutter designs; landscaping; parking lot layouts; titles; and scales. A commercial site plan is shown in Figure 24.86.

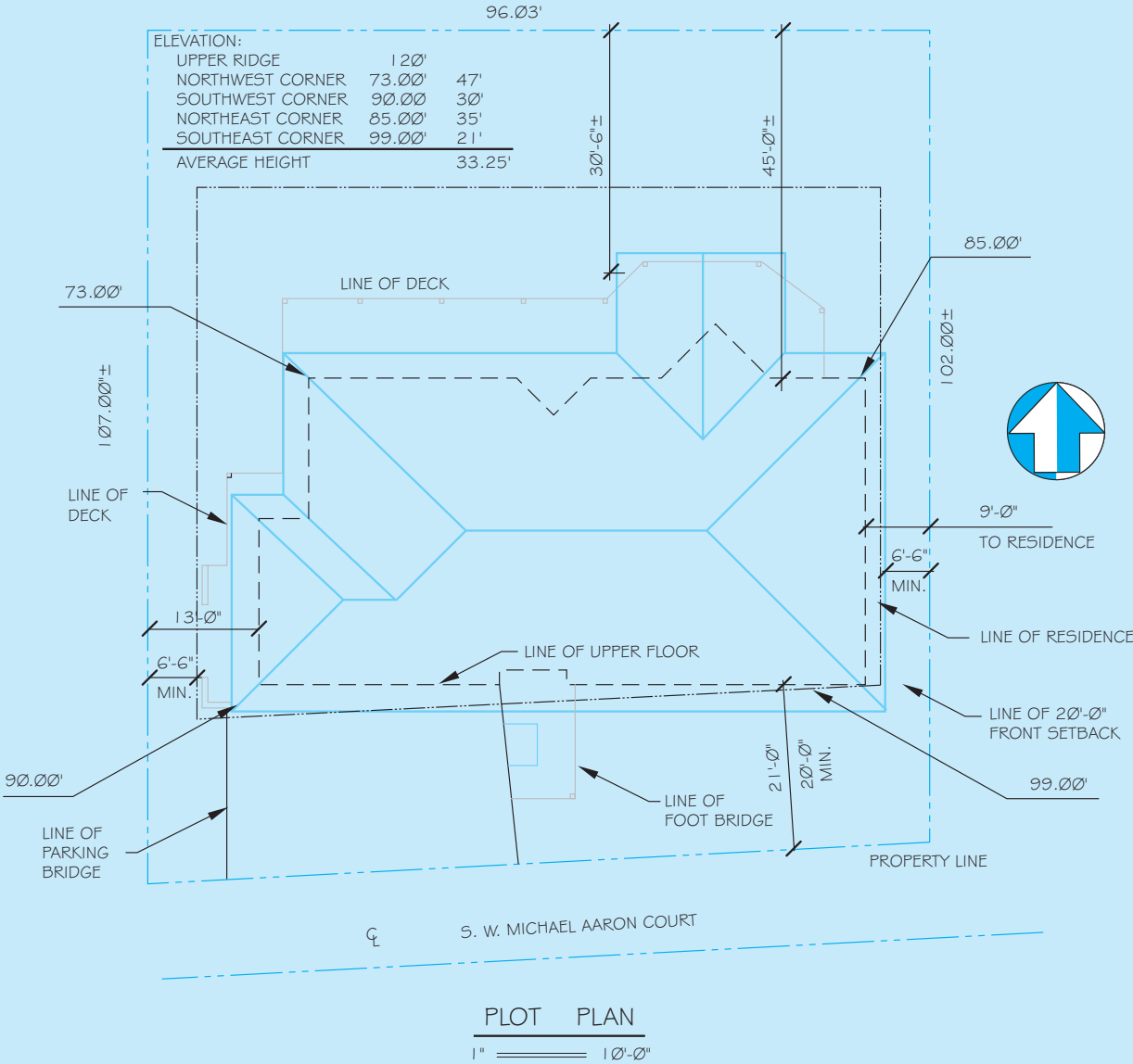


FIGURE 24.85 A CADD-drawn site plan. © Cengage Learning 2012

(Continued)



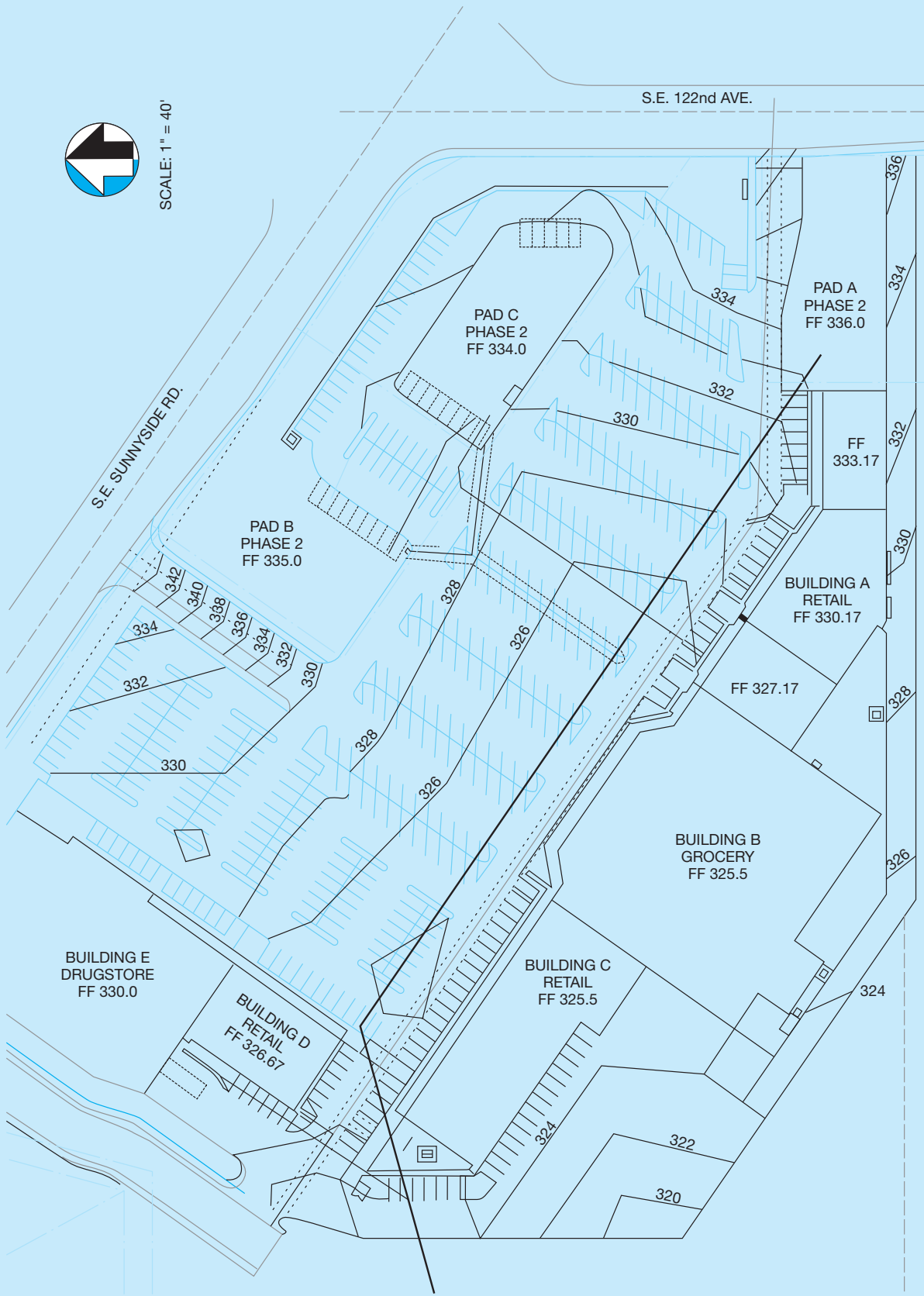
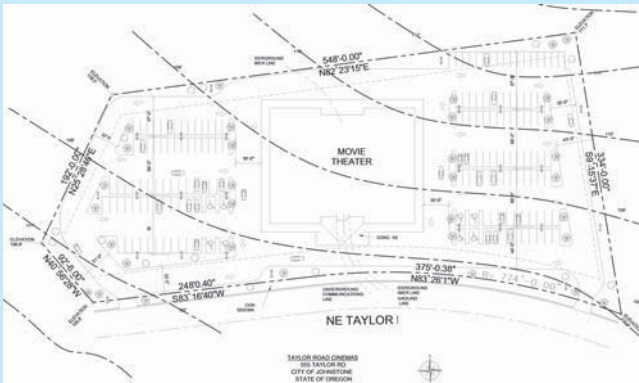


FIGURE 24.86 A CADD-drawn commercial site plan. Courtesy Soderstrom Architects, PC

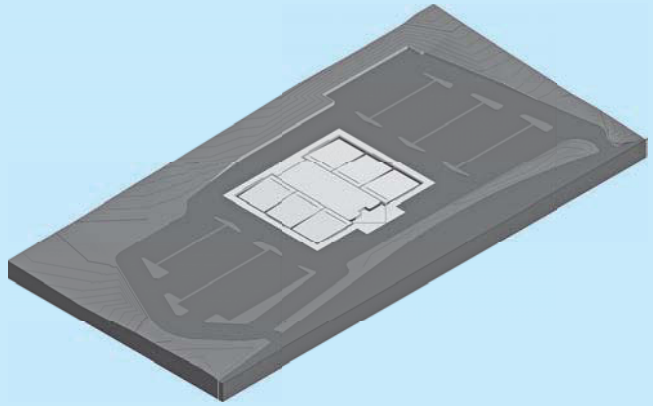
## DEVELOPING A CADD TERRAIN MODEL

CADD programs are available that allow you to include site work, landscaping, roads, driveways, retaining walls, and construction excavation as part of the project. A terrain model can be created from survey data or from a topographic site plan. Figure 24.87 shows an example of a topographic site plan to be used for developing a terrain model. A **terrain model** shows the land contour in three dimensions. The CADD program recognizes the contour lines or survey data and creates a 3-D model in wireframe or as a 3-D terrain model, as shown in Figure 24.88. The terrain model can be viewed from any angle to help you fully visualize the contours of the site. Now the terrain model can be used for any of the following design applications:

- Define borders and property lines.
- Find the elevation at any point, contour line, surface object, or feature and modify the elevation to determine how this affects the model.



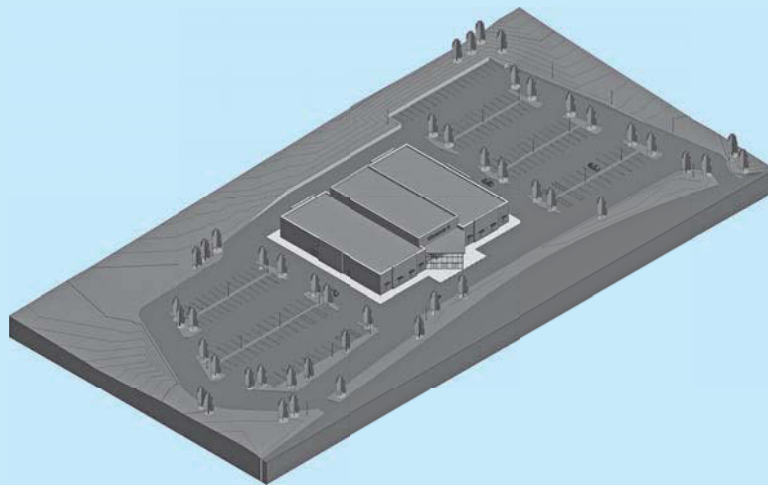
**FIGURE 24.87** A topographic site plan to be used for developing a terrain model. *Courtesy 3D-DZYN*



**FIGURE 24.88** The CADD program recognizes the contour lines from the site plan in Figure 24.87 and creates a 3-D-terrain model. *Courtesy 3D-DZYN*

- Modify the terrain model by editing the contour shapes.
- Define and display building excavation sites, roads, and other features.
- Show and calculate cut and fill requirements.
- Display the model in plan or 3-D view.

When the site is designed as desired, the 3-D rendering of the building can be placed on the site, as shown in Figure 24.89. This is an excellent way to demonstrate how a project will look when it is finished.



**FIGURE 24.89** When the site is designed as desired, a 3-D rendering of the house can be placed on the site. *Courtesy 3D-DZYN*

## CADD LAYERS FOR SITE PLAN DRAWINGS

The American Institute of Architects (AIA) CADD Layer Guidelines establish the heading Civil Engineering and

Site Work as the major group for CADD layers related to site plans. The following are some of the recommended CADD layer names for site plan applications.

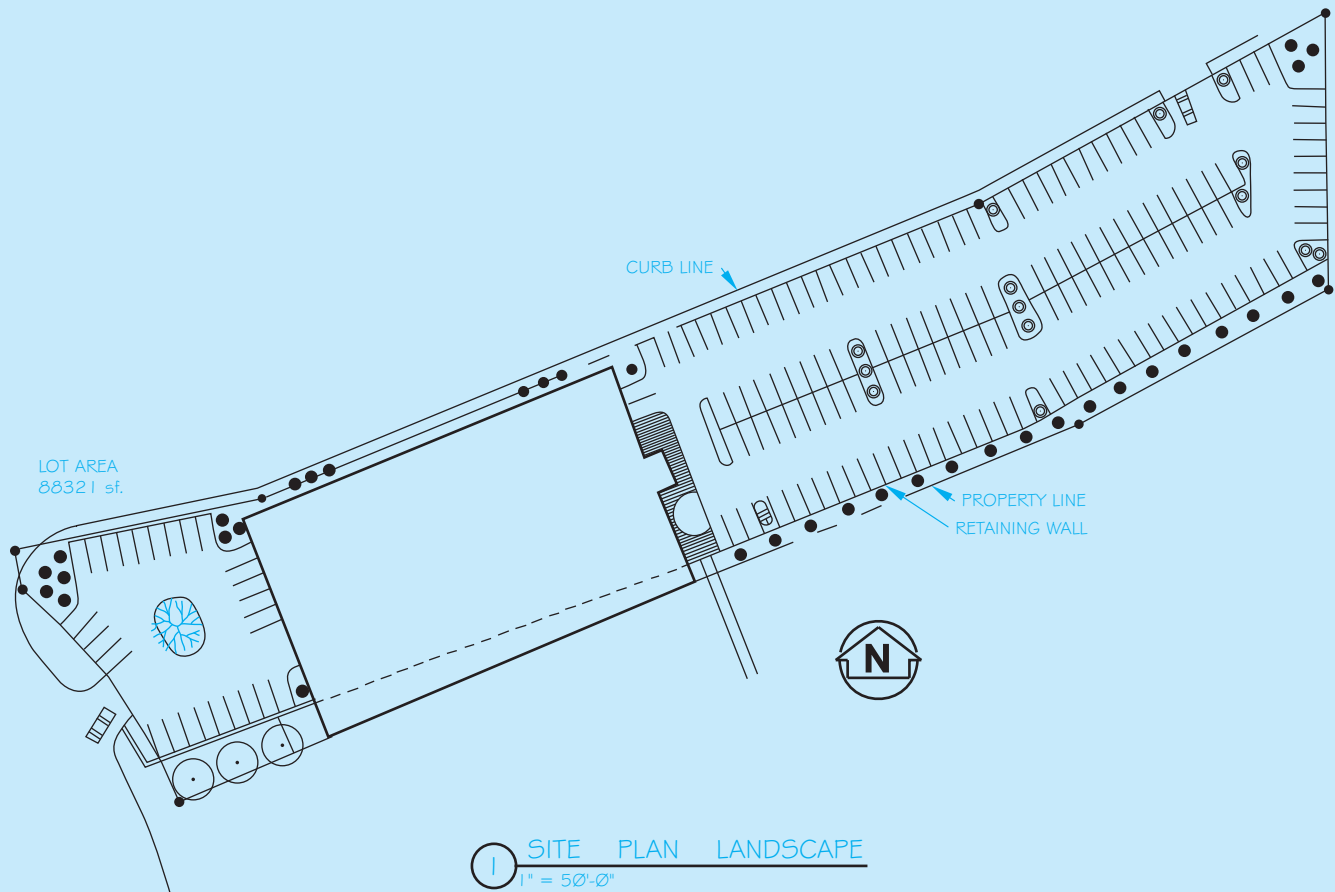
Layer Name	Description
C-PROP	Property lines and survey bench marks
C-TOPO	Proposed contour lines and elevations
C-BLDG	Proposed building footprints. The term <i>footprint</i> is often used to describe the area directly below a structure
C-PKNG	Parking lots
C-ROAD	Roads
C-STRM	Storm drainage, catch basins and manholes, C-COMM site communications systems, such as telephone
C-WATR	Domestic water
C-FIRE	Fire protection hydrants, connections
C-NGAS	Natural gas systems
C-SSWR	Sanitary sewer systems
C-ELEV	Elevations
C-SECT	Sections
C-DETL	Details
C-PSIT	Site plan
C-PELC	Site electrical systems plan
C-PUTL	Site utility plan
C-PGRD	Grading plan
C-PPAV	Paving plan
C-P***	Other site, landscape

Landscape plans also have CADD layer designations, with the major heading Landscape Architecture. Landscape plans generally show the suitable plants for the site and specify the plants by their proper Latin names and sometimes their common names. The architect or designer often sends the site plan computer drawing file to the landscape architect or designer where the file is used to specify the size, type, and location of the plants. Details for maintaining the plants, such as a water-sprinkler system and other care requirements are also provided on the landscape plan. Figure 24.90

shows a CADD landscape plan without detailed plant information given on the drawing. In this case, the plant information was given in a set of written specifications. The following are some of the commonly used layer names.

Layer Name	Description
L-PLNT	Plant and landscape materials
L-IRRG	Irrigation systems
L-WALK	Walks and steps

(Continued)



**FIGURE 24.90** The landscape plan shows tree and planting locations. Plant types can be included on the landscape plan or in a separate document as with this example. Courtesy Soderstrom Architects

## GREEN TECHNOLOGY APPLICATION

### GOING GREEN: DESIGNING YOUR ECO-SYSTEM

The content for this Going Green feature is taken in part from *Mascord Efficient Living, Building a Sustainable Lifestyle*.

#### WHAT IS AN ECOSYSTEM?

The ecosystem is important to our lifestyles, and it is fragile. An ecosystem is an ecological community that functions as a unit with its environment. Site disturbance from construction practices unbalance the local system in ways that may not be apparent at first glance. Minor site changes can have a large impact locally and regionally.

Clearing landscape for construction can cause problems with the management of storm water, dust, and erosion. The site can become unstable, and landslides can occur if the ground becomes saturated and cannot deal with storm water. In addition, local storm water systems can be flooded with runoff containing dust, debris, and silt.

Plants imported for landscaping can be invasive and may not blend with local conditions, causing the homeowner unnecessary maintenance costs. Plant species introduced into areas where they are not native can negatively impact local species. A strong invasive species can eradicate a more delicate native species and possibly remove a food source for local wildlife.

Care is needed when working with the site to prevent unnecessary disturbance of local systems and to reduce costs associated with clearing and relandscaping areas. Mature plants are well established and need less attention than freshly planted seedlings. A well-designed, climate-appropriate landscape offers substantial environmental and economical benefits. Trees and other vegetation control erosion, protect water supplies, provide food and habitat for wildlife, and clean the air. Planting trees, shrubs, bushes and hedges can also be an effective way to provide shade and reduce your heating and cooling costs. Parallel to understanding how your landscape works as an ecosystem, approach your landscape with its unique visual appeal in mind. The sights, textures, and scents of your home's landscape might prove to be the most beautiful and inspiring of all your home's efficient features.

## Shading

Using landscape shade properly requires you to understand the size, shape, and location of the moving shadow that your landscaping elements cast throughout the year and as they mature. Landscaping elements can be used to block sun from windows and shade your walls and walkways from hot summer rays, providing a method to reduce the cooling needs of your home. Trees can be selected with appropriate sizes, densities, and shapes for almost any shading application. Deciduous trees, for example, can be planted to block solar heat in the summer and let more heat in during the winter. Alternately, the properties of dense evergreen trees or shrubs can provide continuous shade and serve to disperse winds. **Shading** and **evapotranspiration** from trees reduces surrounding air temperatures by as much as 9°F. Because cool air settles near the ground, air temperatures directly under trees can be as much as 25°F cooler than air temperatures above. Evapotranspiration is the process by which a plant actively moves and releases water vapor.

## Xeriscaping

**Xeriscaping** is a term for low water use landscaping, while designing using native plants is called **naturescaping**. Xeriscape gardens have typically been implemented in areas of the country where there is a hot and dry climate. However, busy homeowners everywhere are finding the ease of a low-maintenance garden appealing. Xeriscaping and naturescaping reduce the need for watering, weeding, fertilizing, and spreading chemicals. Xeriscape design does not



**FIGURE 24.91** An example of xeriscaping and naturescaping.

need to consist of plants such as cactus or rocks and bark dust. Good design concentrates on locating plants where the species can thrive naturally and by using defined areas of irrigation for water conservation rather than eliminating water use altogether. Mixing drought-tolerant plants with well chosen areas of irrigated plants can produce a beautifully colored and varied garden, with low maintenance and low water requirement. For example, instead of a large lawn expanse with a high volume sprinkler system, use a smaller lawn bordered with drought-tolerant plants. Add a side flower bed planted with well chosen species using an appropriately sized irrigation system. This provides a much more interesting landscape with a colorful array of flowers while using a lot less water—with less maintenance. Figure 24.91 shows an example of xeriscaping and naturescaping.

## Naturescaping

The use of native plants in your landscape can balance the ecosystem of the garden, because they have evolved over time to be tolerant to their surroundings. Native plants can provide correct nutrients to balance the soil, provide food for local wildlife, prevent the intrusive behavior of weeds, and also prevent erosion. However, you don't need to limit yourself to native plants when designing a landscape. Irises, roses, lavender, lambs' ears, Oriental poppy, dusty miller, and tulips are all examples of plants that should survive in a low-maintenance garden without overpowering native species. The greatest pleasure of having a xeriscaped and naturescaped garden is being able to enjoy the landscape without spending too much time mowing, pruning, weeding, and fertilizing.

Courtesy of Alan Mascard Design Associates, Inc.

## Hydrozoning

**Hydrozoning** involves arranging flowers and plants into areas that need similar amounts of water and nutrients. Watering requirements are more easily managed if plants can be placed in defined areas of foliage with similar needs. Keeping thirsty plants away from your house also prevents you from needing to soak the foundation wall when watering.

## Irrigation

When designing an automatic **irrigation** system, make sure to use smart, programmable sprinkler systems with moisture sensors that allow you to measure the amount of water your garden needs at any given time. Typically, these systems also allow you to control irrigation from a central shutoff valve. Include a reliable rain sensor so you do not water when raining. Combine this system with a rain- and wastewater-collection system to maximize efficiency. Choose landscaping elements that are appropriate to the local climate and require minimal additional water. The varying root systems of grass, trees, and flowers all have different water requirements. Group plants according to the amount of water they need and design the irrigation system to accommodate the specific plans.

## Know Your Insects

Insects can be beneficial and are often an essential part of a garden ecosystem. Most plants can survive losing more than 25% of their leaf surface. If the soil is healthy, many plants outgrow the pests or diseases that afflict them, and there may be a delay between the initial damage caused by pests and the arrival of beneficial insects that can control them. To determine if an insect is a pest or a beneficial addition to your landscape

ecosystem, refer to gardening books or take a sample to a nursery or garden center that has a knowledgeable staff.

## Pesticides

The **pesticides** and fertilizers used on landscaping end up in the water system. Because many pesticides are highly toxic to fish and other aquatic life, even a small amount can be harmful if it continues into the food chain. If you determine that a pest or disease problem requires intervention, then make sure to use the safest method possible. There are many ways to control pests without using pesticides. For example, set up covers for vegetables, put out traps for slugs, and remove aphids with water jets while watering your plants.

## Building Healthy Soil

**Healthy soil** is the foundation for thriving plants and a healthy lawn. Healthy plants naturally resist diseases and pests, and require less care. Adding organic material to the soil improves drainage and provides food to the microscopic creatures that provide plant nutrients. Add 2 to 3 in. of compost or aged manure every year by turning it into the soil and reuse it as mulch around plants.

## Working Your Yard

In addition to visual appeals, your yard and garden can also serve a functional purpose by designating a section of your yard space for planting herbs, spices, fruits, and vegetables that pay back over time by reducing the amount of produce you need to buy. You can keep it simple by starting out with a few simple herbs. Your garden matures quickly and becomes sustainable.

## PROFESSIONAL PERSPECTIVE

This chapter has touched on the basic portions of civil engineering drafting, with an overview of surveying fundamentals. The civil drafter needs to keep in mind the overall scope of the project when putting it together. The various phases of completing a project require the drafter to work with the

different disciplines. It takes a great deal of well-organized thought and planning to synthesize the material and produce a high-quality graphic document. In your work, keep the broad scope of the project in mind.

When finding the degree of curve (D) for a roadway or utility line, the use of the law of cosines is helpful. To use this law, you must know two sides and the included angle or know all three sides. In finding the degree of curve, you know the three sides: Two sides are simply the radius of the curve, and the third side is the 100 foot chord. The law of cosines follows:

$$a^2 = b^2 + c^2 - 2bc(\cosine A)$$

in which  $A$  = the angle to be determined

$a$  = the side opposite the  $A$  angle (the 100 foot chord)

$b$  and  $c$  = the radius of the curve

The formula can then be rewritten for your purposes:

$$a^2 = 2b^2 - 2b^2 (\cos A) \text{ or } \cos A = (2b^2) - (a^2) + (2b^2)$$

For example, if the radius of a curve is 145.62 feet, then the formula would appear as follows:

$$\cos A = [2(145.62)^2 - 100^2] + [2(145.62)^2]$$

$$\cos A = 32,410.3688 + 42,410.3688$$

$$\cos A = 0.764208$$

Use the second function on your calculator to obtain the inverse cosine; the angle is  $40^{\circ}9'48''$ .

The use of the simple formula shown in the discussion with Figure 24.41, page 1088, gives the same answer. Double the angle after you find the sine of the angle using the 50 foot side.



### Engineering Drawing and Design Math Applications

For complete information and instructions for engineering drawing and design math applications, go to the Student CD, select **Reference Material** and **Engineering Drawing and Design Math Applications**.

## WEB SITE RESEARCH

Use the following Web sites as a resource to help find more information related to engineering drawing and design and the content of this chapter.


Address	Company, Product, or Service
seek.autodesk.com	Autodesk Seek Web service
www.aia.org	American Institute of Architects (AIA)
www.amazon.com	Search author, Madsen, for <i>Architectural Drafting and Design</i> , <i>Architectural Drafting Using AutoCAD</i> , and <i>Architectural Desktop and Its Applications</i> textbook titles
www.ansi.org	American National Standards Institute (ANSI)
www.arcat.com	Building materials information, specifications, and CAD details
www.asme.org	American Society of Mechanical Engineers (ASME)
www.buildingteam.com	Building and construction industry links
www.capterra.com	Construction documents and management software
www.csc-dcc.ca	Construction Specifications Canada (CSC)
www.csinet.org	Construction Specifications Institute (CSI)
www.cengage.com	Publisher of the textbooks <i>Architectural Drafting and Design</i> by Jefferis, Madsen and Madsen, and <i>Print Reading for Architecture and Construction Technology</i> by Madsen, Jefferis
www.greenformat.com	Construction Specifications Institute GreenFormat™
www.g-w.com	Publisher of the textbooks <i>Architectural Drafting Using AutoCAD</i> by David A. Madsen, Ron Palma, and David P. Madsen

(Continued)

www.hud.org	U.S. Department of Housing and Urban Development (HUD)
www.nahb.org	National Association of Home Builders (NAHB)
www.precast.org	National Precast Concrete Association (NPCA)
www.prnewswire.com	Willamette Industries
www.steel.org	American Iron and Steel Institute (AISI)
www.steel-sci.org	Steel Construction Institute (SCI)
www.strongtie.com	Simpson Strong Tie information and catalog
www.tilt-up.org	Tilt-Up Concrete Association (TCA)
www.uss.com	U.S. Steel Corporation (USS)
www.wirereinforcementinsitute.org	Wire Reinforcement Institute (WRI)
www.world-aluminum.org	International Aluminum Institute (IAI)
www.worldsteel.org	International Iron and Steel Institute

# Chapter 24

## Chapter 24 Civil Drafting Test

 To access the Chapter 24 test, go to the Student CD, select **Chapter Tests and Problems**, and then **Chapter 24**. Answer the questions

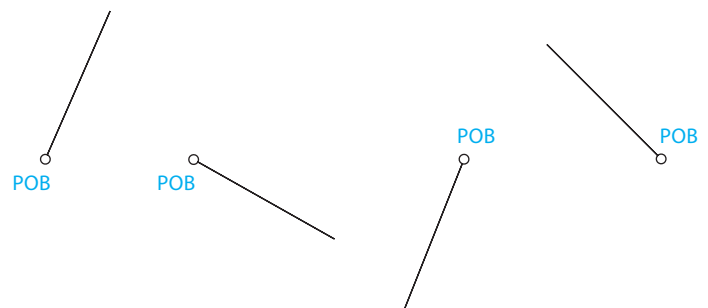
with short, complete statements, sketches, or drawings as needed. Confirm the preferred submittal process with your instructor.


## Chapter 24 Civil Drafting Problems

### INSTRUCTIONS

Determine the sheet size based on the drawing requirements. Use a border and architectural-style title block as described in Chapter 22, *Structural Drafting*. Metric scales can be substituted if preferred by your supervisor or instructor. Include a north arrow and note the scale where applicable.

**PROBLEM 24.2** Give the azimuth angles as well as the bearings of the lines shown. Fill in the values in the following table.



 **Drafting Templates**

To access CADD template files with predefined drafting settings, go to the Student CD, select **Drafting Templates**, and then select the appropriate template file.

### Part 1: Problems 24.1 Through 24.11

**PROBLEM 24.1** Draw an open traverse at a scale of 1" = 20' using the following information:

From POB, traverse 34.23' at S61°42'E, then 15.69' at S44°7'E, then 40.89' at N78°48'E, then 39.33' at N56°14'E. Be sure to label each course.

Line	Azimuthal Angle	Bearing
AB		
CD		
EF		
GH		

© Cengage Learning 2012



**PROBLEM 24.3** Draw a traverse at a scale of 1" = 20' using the following lengths and bearings. What kind of traverse is this?

21 feet at N40°7'E, 77 feet at S84°9'E, 19 feet at S25°29'E, 48 feet at S39°22'W, 31 feet at S76°9'W, 65 feet at N34°57'W.

**PROBLEM 24.4** Transfer the information shown on the following figure. Then draw a traverse at a scale of 1" = 20' using the following lengths and azimuth angles. What kind of traverse is this?

23 feet at an angle of 131°40', 11 feet at an angle of 231°8', 36 feet at an angle of 113°25', 49 feet at an angle of 64°39', 27 feet at an angle of 303°50', 36 feet at an angle of 65°33'.

POB

© Cengage Learning 2012

KNOWN POINT

**PROBLEM 24.5** Transfer the information shown on the figure below. Then draw a deflection angle traverse at a scale of 1" = 40' using the following lengths and bearings. Be sure to use proper notation for the deflections. What type of traverse is this?

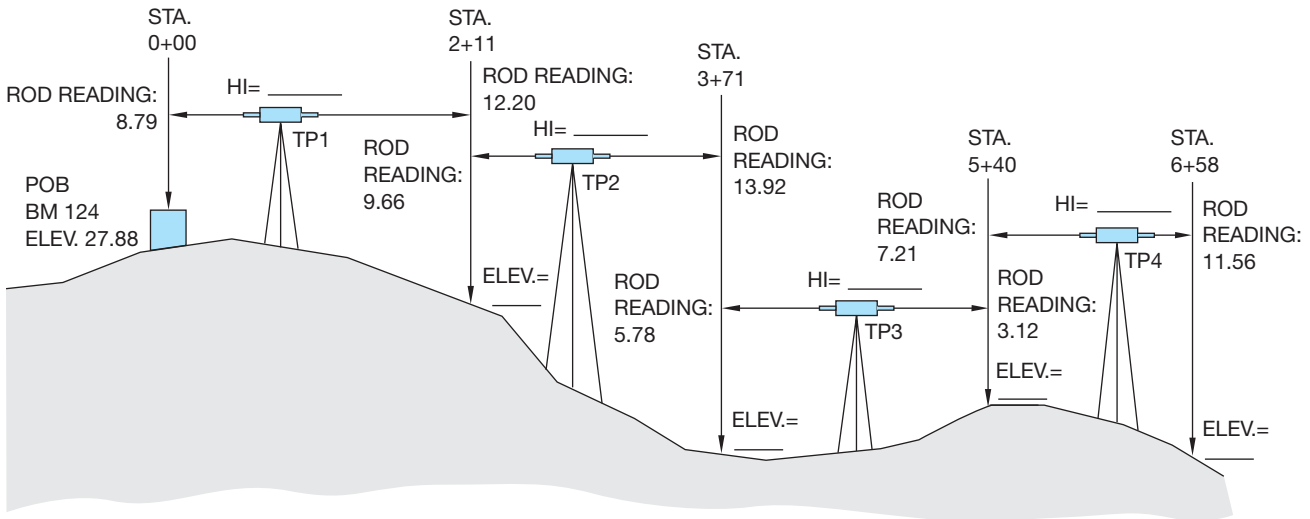
48' at S63°46'E, 33' at S37°32'E, 71' at N86°10'E, 23' at S81°4'E, 73' at S73°9'E.

POB

© Cengage Learning 2012

BENCH MARK

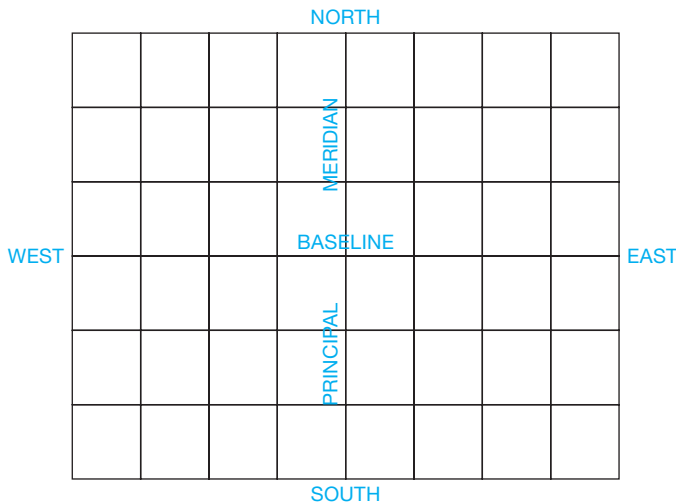
**PROBLEM 24.6** Complete the leveling notes that were gathered by the survey crew. Create a leveling notes table and fill in the HI and elevations for each station.



© Cengage Learning 2012

**PROBLEM 24.7** Draw the grid and mark the following townships as shown:

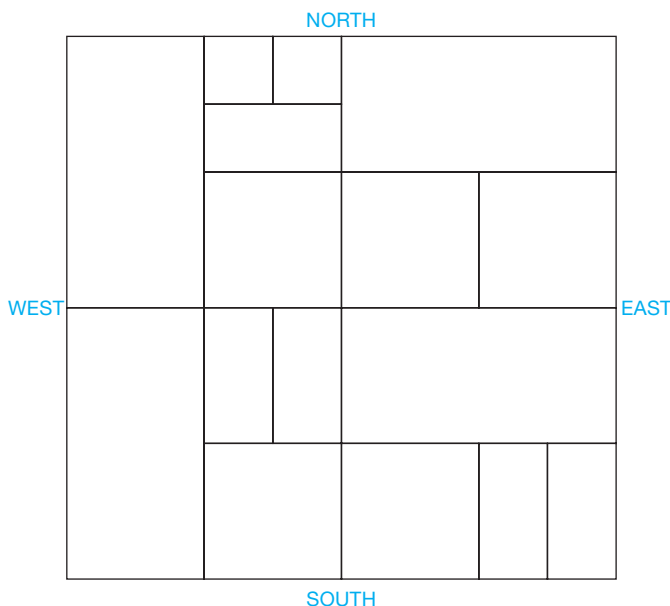
- A Township: T2S, R2W
- B Township: T3N, R4E
- C Township: T1N, R2E
- D Township: T2S, R2E
- E Township: T1N, R4W



© Cengage Learning 2012

**PROBLEM 24.8** Draw the section grid and mark the following parcels of land as shown:

- A Parcel: SW 1/4, SE 1/4
- B Parcel: W 1/2, NW 1/4
- C Parcel: W 1/2, NE 1/4, SW 1/4
- D Parcel: NE 1/4, NE 1/4, NW 1/4
- E Parcel: E 1/2, SE 1/4, SE 1/4



© Cengage Learning 2012

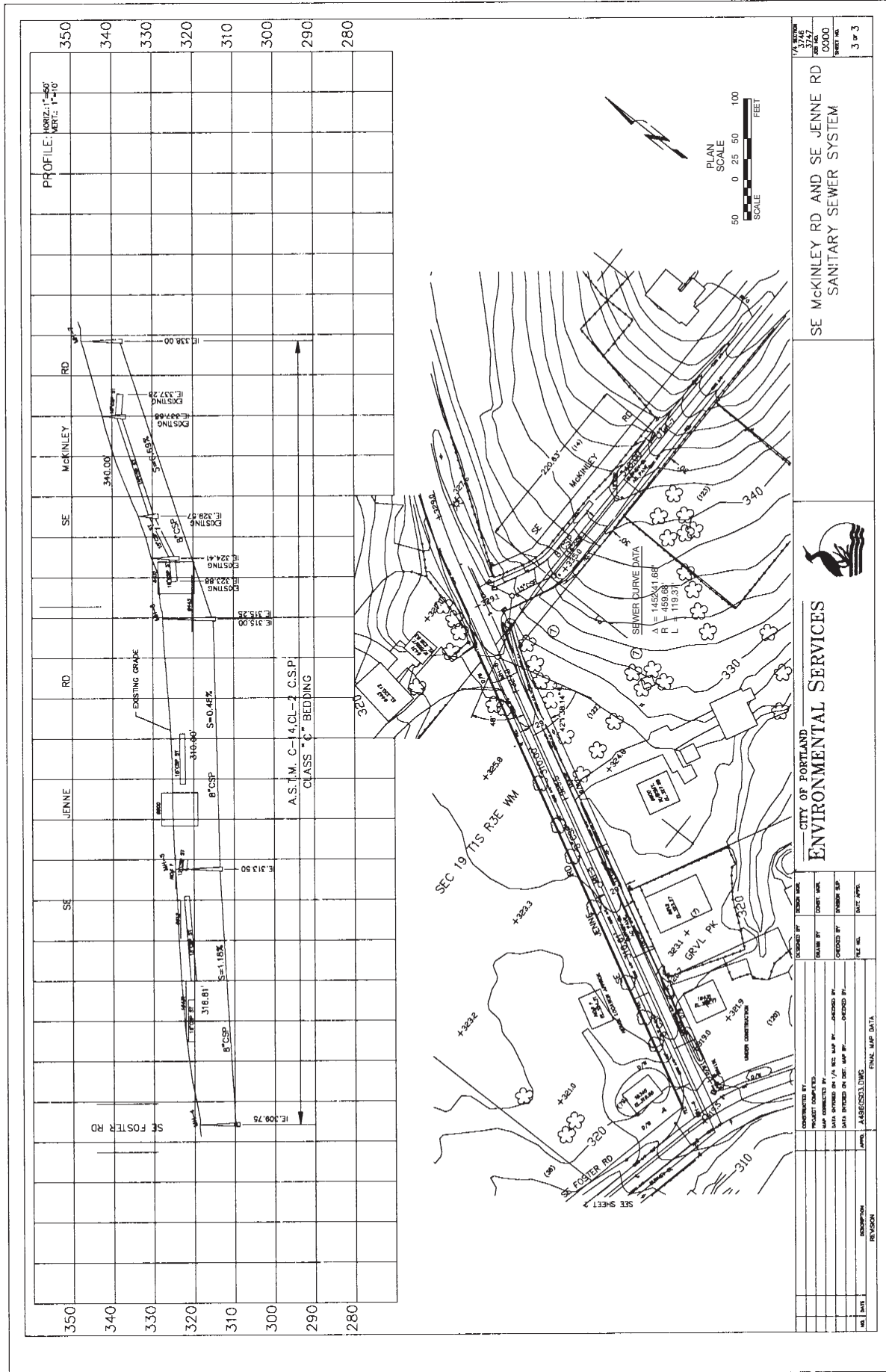
**PROBLEM 24.9** Complete the leveling notes that were gathered by the survey crew. Then plot the resulting profile using 1" = 10' for the vertical scale and 1" = 40' for the horizontal scale.

Station	B.S. (+)	H.I.	F.S. (-)	Elevation
BM 12	17.31		7.46	34.12
0 + 30	6.83		4.87	
0 + 55	9.66		7.72	
1 + 05	14.30		10.13	
1 + 45	12.20		13.29	
1 + 85	7.12		15.82	
2 + 15	10.04		12.73	
2 + 40				BM 13

© Cengage Learning 2012

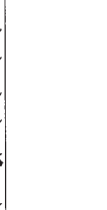
**PROBLEM 24.10** Answer the following question using the drawing on page 1124.

- What is the vertical scale?
- What is the horizontal scale?
- What is the degree of curve of the sewer?
- Where is the property located in relation to the public-land survey?
- If the IE at MH-4 is 309.75 and the IE at MH-5 is 313.50, then what is the grade slope?
- What is the contour interval?



DATE: 3/7/10  
 DRAWN BY: JAC  
 CHECKED BY: JAC  
 PROJECT NO.: 0000  
 SHEET NO.: 3 of 3

SE MCKINLEY RD AND SE JENNE RD  
 SANITARY SEWER SYSTEM



PLAN SCALE: 1" = 40'  
 SCALE: 1" = 40'  
 FEET

CITY OF PORTLAND  
 ENVIRONMENTAL SERVICES

NO.	DATE	DESCRIPTION	REVISION

DESIGNED BY: JAC  
 CHECKED BY: JAC  
 DRAWN BY: JAC  
 DATE: 3/7/10

**PROBLEM 24.11** Complete the unknown values that were given at the beginning of the chapter (see Figure 24.2, page 1072).

Station	Transit Line for Valerian Lane From Erika Street (Bearing N56°16'W) to Quincey Avenue (Bearing N31°25'W)
0 + 00 Begin Project	255.78'N67°37'W from BM 151 to centerline of Erika Street. Then 132.00'S33°44'W to P.C.
STA 1 + 32	P.C. to the left Curve Data R = 200' $\Delta = 47^\circ 23'$ L = _____ D = _____
STA _____	P.R.C. Curve Data R = 170' $\Delta = 72^\circ 15'$ L = _____ D = _____
STA _____	P.T.
STA _____ End Project	S58°36'W from STA _____ to centerline of Quincey Avenue

© Cengage Learning 2012

**Part 2: Problems 24.12 Through 24.19**

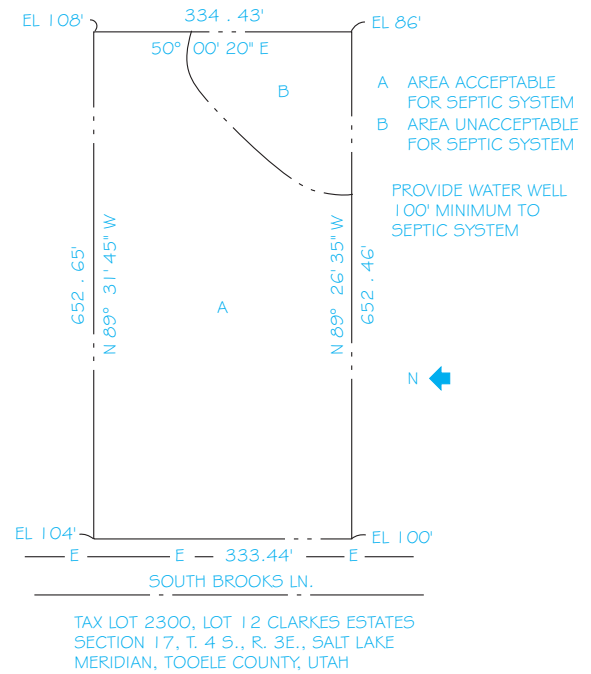


To access the Chapter 24 problems, go to the Student CD, select **Chapter Tests and Problems** and **Chapter 24**, and then open the problem of your choice or as assigned by your instructor. Solve the problems using the instructions provided on the CD, unless otherwise specified by your instructor.

**Part 3: Problems 24.20 Through 24.26**

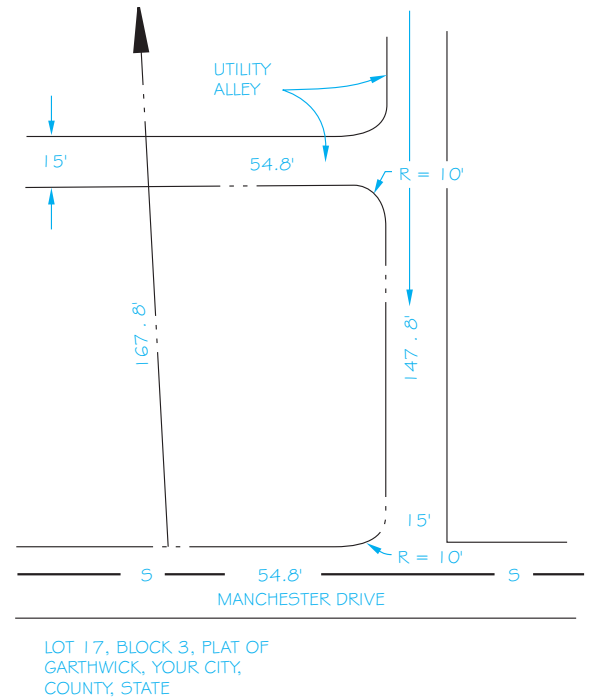
Draw the plot plans from the given sketches or layouts.

**PROBLEM 24.20**



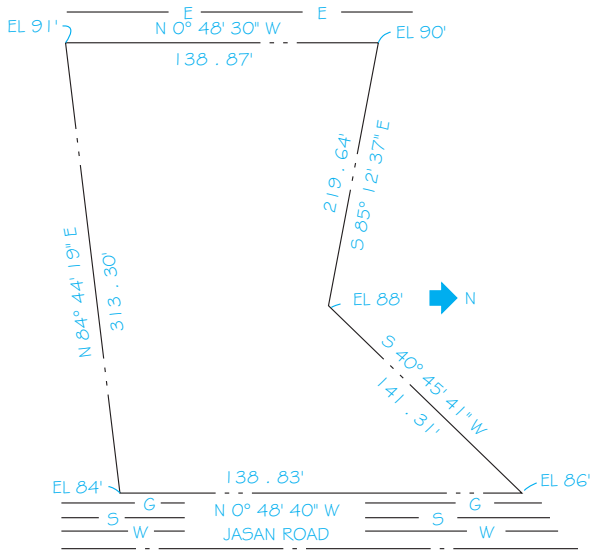
© Cengage Learning 2012

**PROBLEM 24.21**



© Cengage Learning 2012

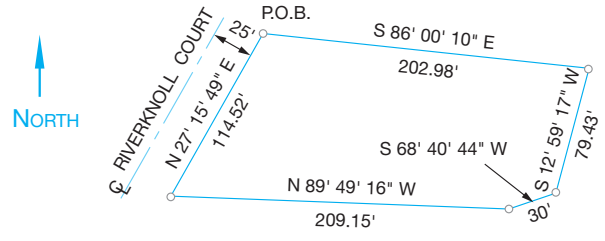
PROBLEM 24.22



LOT 7, BLOCK 2, KYLEE ESTATES  
SECTION 12, T. 12 N., R. 14 E., LOUISIANA  
MERIDIAN, RAPIDES PARISH, LOUISIANA

© Cengage Learning 2012

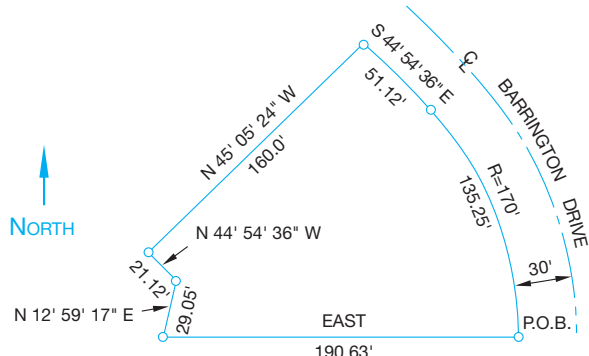
PROBLEM 24.24



LOT 15  
BLOCK 3  
BARRINGTON HEIGHTS  
YOUR CITY, COUNTY  
STATE

© Cengage Learning 2012

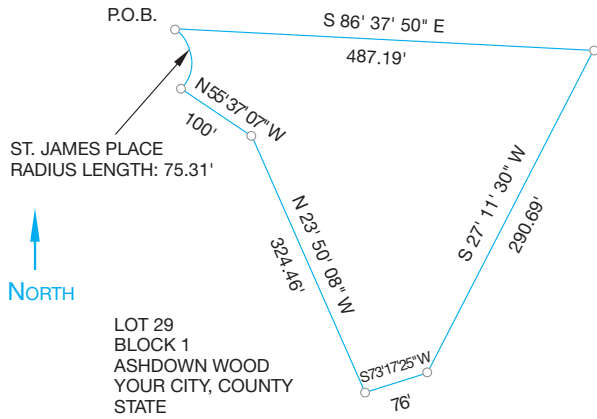
PROBLEM 24.25



LOT 25  
BLOCK 4  
BARRINGTON HEIGHTS  
YOUR CITY, COUNTY  
STATE

© Cengage Learning 2012

PROBLEM 24.23

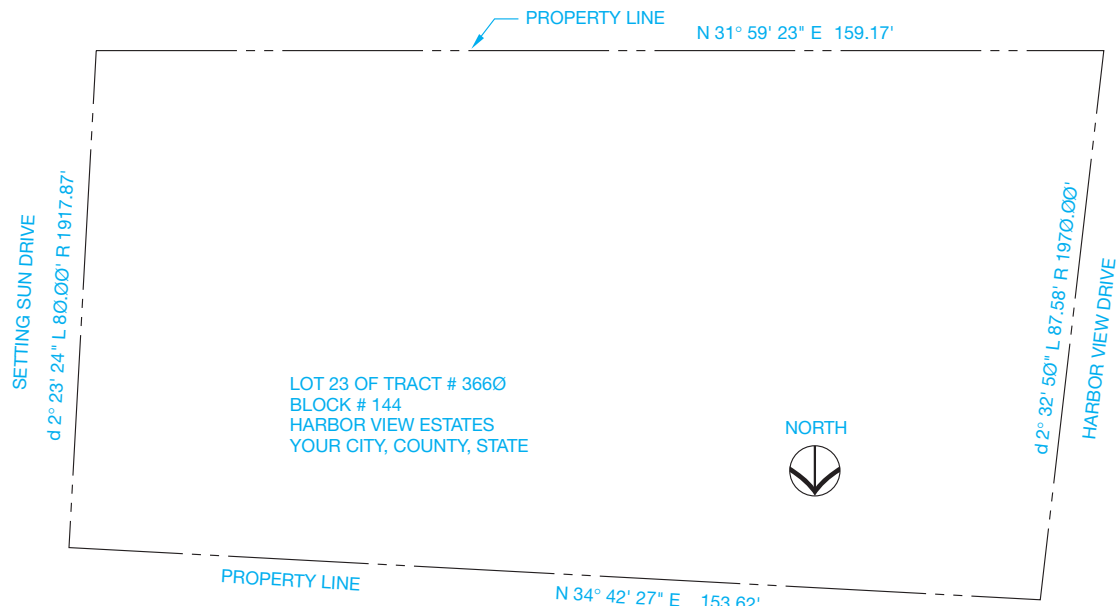


ST. JAMES PLACE  
RADIUS LENGTH: 75.31'

LOT 29  
BLOCK 1  
ASHDOWN WOOD  
YOUR CITY, COUNTY  
STATE

© Cengage Learning 2012

PROBLEM 24.26



LOT 23 OF TRACT # 3660  
BLOCK # 144  
HARBOR VIEW ESTATES  
YOUR CITY, COUNTY, STATE



© Cengage Learning 2012

**Part 4: Problems 24.27 and 24.28**

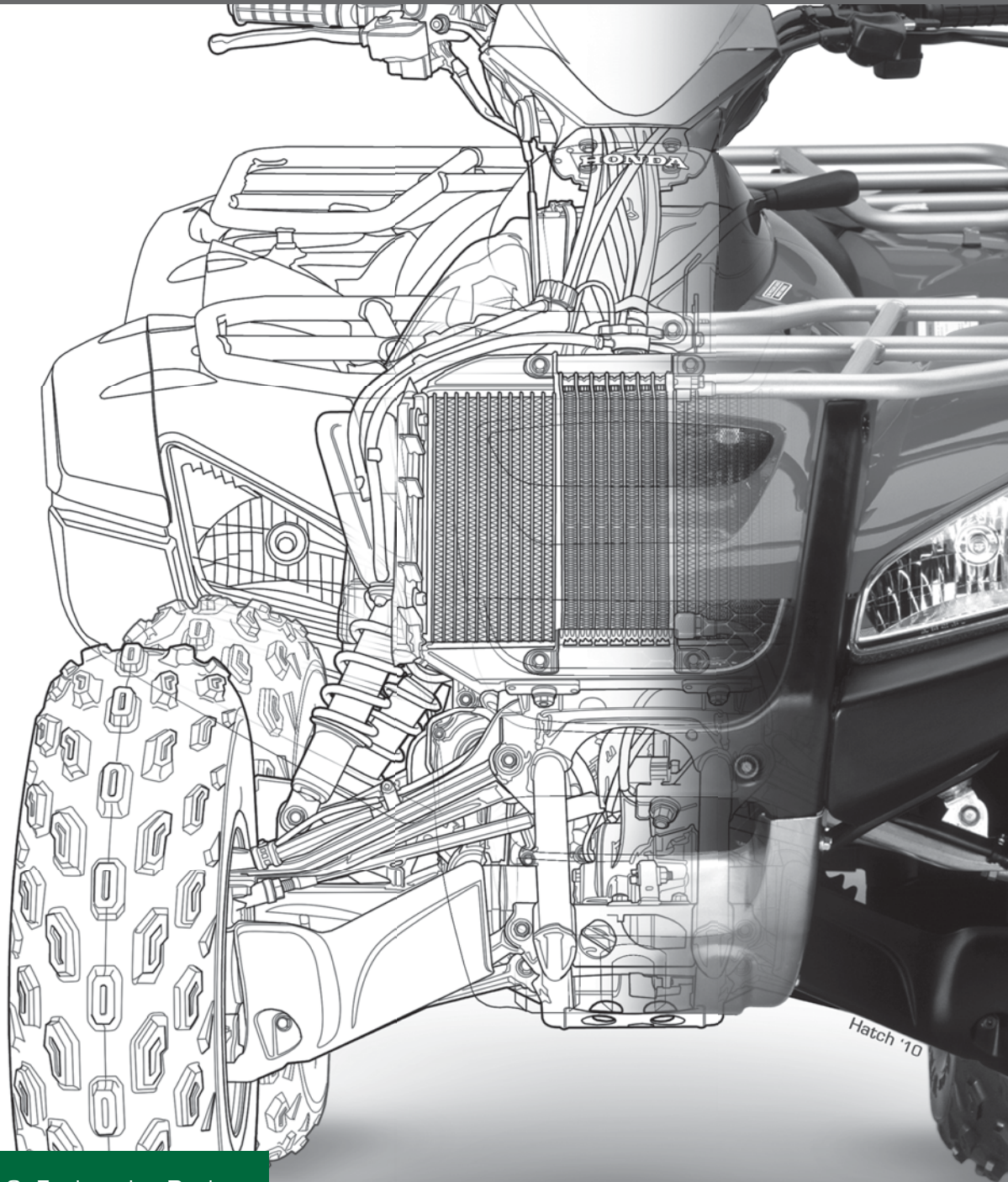
To access the Chapter 24 problems, go to the Student CD, select **Chapter Tests and Problems** and **Chapter 24**, and then open the problem of your choice or as assigned by your instructor. Solve the problems using the instructions provided on the CD, unless otherwise specified by your instructor.

**Math Problems****Part 5: Problems 24.29 and 24.30**

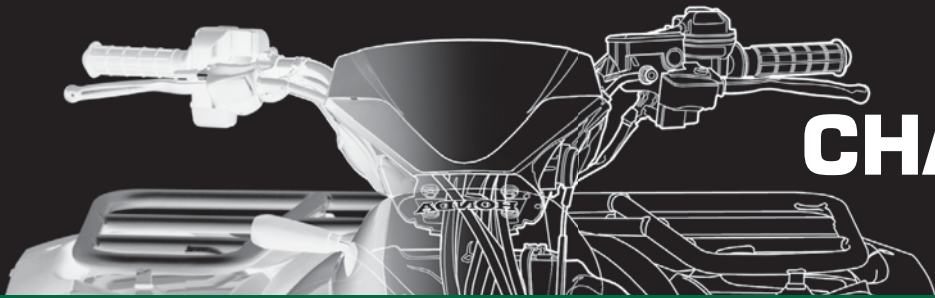
To access the Chapter 24 problems, go to the Student CD, select **Chapter Tests and Problems** and **Chapter 24**, and then open the math problem of your choice or as assigned by your instructor. Solve the problems using the instructions provided on the CD, unless otherwise specified by your instructor.



Engineering Design







# CHAPTER 25

## The Engineering Design Process

### LEARNING OBJECTIVES

After completing this chapter, you will:

- Describe various factors that are changing the design process.
- Describe innovative systems designed to remove waste from the process.
- Discuss the steps in a design analysis process.
- Explain the importance of creativity and innovation in the design product.
- Describe the problem-solving steps used in a design process.
- Explain the importance of concurrent engineering and teams in the development of a product.
- Define today's engineering design models.
- Explain the design review process.
- Describe design deliverables.

## THE ENGINEERING DESIGN APPLICATION

As you begin the study of the engineering design process, it is important to reflect a moment on the past and on how design systems have changed in recent times. Traditionally, an engineering process has been a collection of activities that takes one or more kinds of input and creates an output that is of value to a customer. The delivery of the product to the customer or client is the value that the process creates. This is still true, but how the design process works today is significantly different from how it worked in the past. Engineering has used a design process that goes back to Adam Smith's model for production. The main focus of Adam Smith's 1776 book *The Wealth of Nations* was the concept of economic growth. Growth, according to Smith, is rooted in the division of labor. This idea relates to the specialization of the labor force, with dividing large jobs into many small components. Efficiency increases because each worker becomes an expert in one isolated area of production under this philosophy.

Traditionally, engineering, testing, manufacturing, marketing, cost analysis, and delivery have been components of the design cycle. Each component has functioned independently, with communication occurring only when the design was passed on to the next group. Often the larger objective of customer satisfaction and product quality was lost with the individual focus on the task at hand. Revisions and engineering change notices were the rule of the day. Communication from one end of the process to the other was limited to each group's perspective. Cost of production, time to market, and the demand for quality products have driven a change from this linear design engineering process to an integrated approach that brings

together a team of people from all aspects of product development. The team includes engineering, marketing, production, and the customer. This system is referred to as the **whole-systems approach** to design and is the primary way design is occurring in engineering firms today. The whole-systems approach is a process through which the interconnections between systems are actively considered, and solutions are sought that address multiple problems at the same time. Some refer to this process as the **search for solution multipliers** (see Figure 25.1).

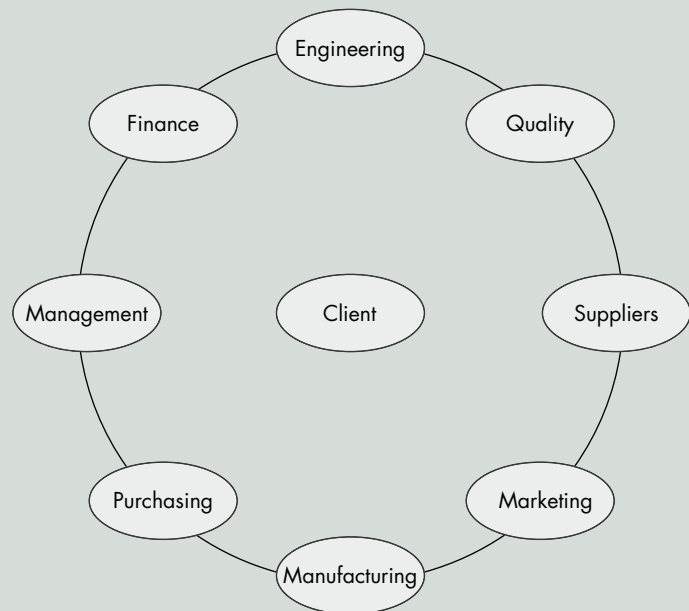


FIGURE 25.1 The design team. © Cengage Learning 2012

The design process today is influenced by the need for better, less-expensive, and faster-to-market products. Behind these changes in design is global competition and communication technologies that have accelerated the speed and volumes of information available to designers.

Also, a compression of time has resulted from the **Information Age of Technology**, which creates a need to bring designs faster to market. The need and tools are at hand to design a quality product quickly, using all parties in the design process concurrently.

## INTRODUCTION

Today's designs are driven by cost, market trends, and customer service, as well as by quality and technology. Because of these realities, engineers, designers, drafters, and technicians need to be aware of how their designs fit into the broader function of product development. In turn, they need to understand how their function fits into the entire product development cycle. Finally, this knowledge needs to be carried one step further into the areas of sales and marketing to understand exactly what the company is trying to sell and produce, to whom, and for what purpose. These are the forces behind the change to a whole-systems approach to engineering design.

As a future designer or technician in the engineering profession, it is vital to possess abilities in areas such as problem definition, resource and information acquisition, design review, problem solving, technical communication and teamwork skills, business systems, project management, and, above all, the ability to see the whole system. The basic premise of a whole-systems approach to engineering design is the need for all people in the process to know all the necessary information and actions involved in the design process.

This sharing of knowledge, varying viewpoints, and ideas leads to better, faster, and more efficient problem solving. Accumulated knowledge and the availability of information in the engineering profession are explosive. The ability and tools to gather and archive information are available to the engineering design team more quickly and with less effort than ever before. This surge of information and its availability to everyone has brought a new model for decision making in the design process. The decisions are now made with input from everyone on a design team, not with just a few at the top passing decisions down the line. A person can use this shared data bank of product information for inventory planning, scheduling, purchasing, labor forecasting, or customer service. The power of all this input is a quality product that is cost-efficient and produced faster than in the past.

Traditionally, designers were trained in design fundamentals, the nature of materials, the capabilities of tools and equipment, and manufacturing processes. These skills are still very important to the development of an engineering designer or drafter. Today these skills are expanded to include knowledge of market trends, safety, data acquisition and management, teaming concepts, packaging, distribution, and storage. This is a full systems approach to design. Today's designer faces a world of complex dependencies and interrelationships that

### CHANGING BUSINESS MODEL

DESIGNER (YESTERDAY)	KNOWLEDGE WORKER (TODAY) TEAM MEMBER
DETAIL WORK	INTELLECTUAL WORK
FACTOR OF PRODUCTION	KNOWLEDGE PRODUCER
QUESTION NOTHING	QUESTION EVERYTHING
DO AS YOU ARE TOLD	DETERMINE WHAT TO DO
REPETITIVE TASKS	CONTINUOUS CHALLENGES
SEGMENTED WORK	HOLISTIC WORK
DIRECT SUPERVISION	AUTONOMY

FIGURE 25.2 The changing business model. © Cengage Learning 2012

involve federal and state regulations, environmental impacts, consumer perceptions, economic and social needs, cultural trends, and demographics impacting the design process. These forces have changed the world of engineering design and the fundamental nature of work. The change has moved from a designer assigned to a project to a knowledge-based workforce (see Figure 25.2).

## ENGINEERING DESIGN AND INDUSTRY MANAGEMENT MODELS

The following briefly reviews some of the systems approaches used by the engineering world to address the constantly evolving engineering design process. Although these systems are described separately, they all have characteristics that cross over when companies implement the best possible model for success.

### Kaizen Event

The Japanese term **kaizen** refers to a **continuous improvement** activity that seeks to incrementally eliminate waste and inefficiency. Companies can apply this philosophy as an event-driven activity known as a **kaizen event**. The kaizen event brings all owners and members of a process together to conduct a formal review of the process, ask for feedback from the group, gain support from team members, and work toward processes that can help the organization achieve better results by improving existing processes within the company.

## Just-in-Time (JIT)

**Just-in-time (JIT)** is an inventory approach that seeks to improve return on investment by reducing raw material and production inventory and related costs. JIT evolved into the Toyota production system described next. The JIT process relies on observation between different points in the process to determine when parts are needed. In other words, parts are made just in time. JIT can improve the return on investment, quality, and efficiency in a manufacturing company.

## Toyota Production System (TPS)

The **Toyota production system (TPS)** is a system that recognizes the interaction between people and technology in the workplace. The TPS organizes manufacturing, labor, and materials as needed for the automobile manufacturer, including interaction with suppliers and customers. The TPS is the pioneer of lean manufacturing. The TPS system was originally called just-in-time production. The founders of Toyota were impressed by the assembly line and mass production used by Henry Ford. The basic principle of the TPS is when a customer buys a product, another product takes its place. The value of a process is the production of goods or the provision of a service that customers want, and waste occurs when more resources are consumed than are necessary to produce the goods or provide the service. The attitudes and tools of the TPS increase awareness and give a new perspective on identifying waste and taking advantage of opportunities associated with reducing waste.

Toyota's chief engineer identified the following seven wastes to be improved for the benefit of the company:

1. Overproduction can result in manufacturing more product than is needed to meet demand, resulting in products that must be stored rather than sold. Overproduction is the worst waste because it affects all other forms of waste.
2. Unnecessary transportation involves cost and no added value every time a product is moved. The product also has the risk of being damaged, lost, or reaching the customer late. Product cost can be reduced by eliminating unnecessary transportation.
3. Inventory includes raw materials, work in progress, and finished products that are not sold. Inventory is waste, because no income is generated by inventory.
4. *Motion* refers to property, workers, equipment, and expenses incurred in the production processes. Excess motion can result in wear and damage to equipment, and it can affect worker safety.
5. Defects involve extra costs and waste incurred when it is necessary to **rework** or scrap parts. Reworking is required when parts are not manufactured correctly the first time. Rework also implies that the parts are not scrap and can be made into usable parts, for example, by additional machining. If an out-of-specification part is produced, the company must research the processes and determine the cause of the error. The origin can be many things, such

as improper fixtures, tool wear, operator error, procedures not in place or not properly followed, and inadequate inspection techniques. All of these conditions are wasteful. Defects can also cause production rescheduling, late product delivery to market, and loss of sales.

6. Overprocessing occurs any time more work is done on a piece than what is required by the customer. This includes using tools that are more precise, complex, or expensive than necessary.
7. Waiting causes waste. It is important to keep the wait time to a minimum so that production flows smoothly without delay and products are transported immediately after being manufactured.

## Lean Manufacturing

**Lean manufacturing** is a production practice that eliminates waste in all departments and in all phases from design through manufacturing and to marketing and distribution. Resources are only used to create **value** for the customer. Lean manufacturing works from the perspective of the customer who consumes a product or service. The term *value* is defined as any necessary activity or process that a customer is willing to pay for the resulting product. Also referred to as **lean production** or simply **lean**, the practice is based on the vision of preserving value with less work. Lean manufacturing is a general process management philosophy originating mostly from TPS and identified as lean in the 1990s.

Lean manufacturing applies the philosophy of **economic efficiency**, which refers to the use of resources to maximize the production of goods and services. The idea is that the system is efficient if it provides more products and services without using additional resources. Increasing efficiency and decreasing waste is accomplished using practical methods to determine what is important as a **team** rather than accepting current conditions. The system results in waste reduction, which is an effective way to increase profitability. The team is every person and department in a company working together for the same goals. This includes everyone from the president to the sales representatives. A key to lean is identifying steps in the process that add value and steps that do not add value. To evaluate this, the entire process is separated into the two categories of value and no value. Once value-added work has been separated from waste, waste can still be subdivided into value-added work that may still contain acceptable waste and waste that can be eliminated. It is important for everyone involved to work together across departmental lines to identify waste in the process where it was not previously seen. This waste identification allows manufacturing to cut cost and production time and produce a better product. Technological improvement and redesigning internal and external processes occur while analyzing waste.

The four goals of lean manufacturing systems are as follow:

- Improve quality: A competitive company must understand customer needs and design processes to meet customer expectations and requirements.

- Eliminate waste: **Waste** is any activity that consumes time, resources, or space but does not add any value to the product or service. Lean defines the following seven types of waste. Notice the parallel between TPS and lean defined waste.
  - Overproduction waste happens when there is too much product in production than what is needed to meet the demand.
  - Transportation waste is unnecessary movement of materials and products.
  - Inventory waste is excess inventory not directly required to fill customer orders.
  - Motion waste is extra steps taken by employees because of inefficient processes and practices.
  - Waiting-time waste is periods of delay in processes and production.
  - Overprocessing waste is the reworking and reprocessing of parts not made correctly the first time.
  - Defect waste is parts that do not conform to specifications and must be discarded.

The following are steps used to create an ideal lean manufacturing system:

- Design and use a simple manufacturing system in which inventory is used in production only when needed to fill customer orders. Doing this helps decrease production time, reduces inventory, increases productivity, and improves equipment use.
- Constantly evaluate for product and process improvement in an effort to eliminate and simplify activities that cause waste.
- Continuously improve products, processes, and services over time.
- Evaluate **overall equipment effectiveness (OEE)**, which determines manufacturing effectiveness based on a comparison of manufacturing units among similar industries. OEE measures the overall use of time and material for manufacturing operations and indicates the gap between actual and ideal performance related to design capacity.

## Six Sigma

Six Sigma is a business management strategy originally developed in 1981 by **Motorola, USA**. A **business management strategy** is the design, implementation, and evaluation of different departments that work together to make decisions that allow an organization to achieve its long-term goals. A business management strategy includes a **mission statement**, vision, objectives, policies and plans, projects and programs designed to achieve these objectives, and the allocating resources to implement the objectives. Six Sigma seeks to improve the quality of process outputs by identifying and removing the causes of defects and minimizing **manufacturing** variables. Six Sigma uses **quality management** methods and creates a special network of people within the company who are experts in the use of these methods. Projects using Six Sigma follow a defined sequence of steps with measurable targets. These

targets can be financial, such as cost reduction or increased profits, or customer based, such as improved lead time, better safety, faster delivery, and improved quality. The term **Six Sigma** refers to a *sigma* rating, which indicates the percentage of defect-free products created. A **one sigma** process is 31% free of defects, whereas a Six Sigma process is 99.99966% free of defects. Six Sigma projects follow two project methodologies inspired by W. Edwards Deming's **plan-do-check-act (PDCA)** cycle. Dr. Deming is considered by many to be the father of modern quality control. The basis of the PDCA is repeating a process with the aim of approaching a desired goal, target, or result. Once a proposal is confirmed, the cycle is executed again to extend the knowledge further. Repeating the PDCA cycle can bring the process closer to the goal of perfect operation and output. The following five phases are used for projects aimed at improving an existing process:

1. Define the problem based on customer feedback and project goals.
2. Measure key aspects of the current process and collect related data.
3. Analyze the data to investigate and verify cause-and-effect relationships. Determine what the relationships are and attempt to ensure that all factors have been considered. Seek out the cause of the defect being investigated.
4. Improve and optimize the process based on the analysis. Set up pilot runs to establish process capability.
5. Control the process to ensure that deviations from targets are corrected before they result in defects. Continuously monitor the control systems using methods such as statistical process control.

The following five phases are used for projects aimed at creating new products or process designs:

1. Define design goals that are consistent with customer demands and company goals.
2. Measure and identify product capabilities, production process capability, and risks related to quality.
3. Analyze and evaluate to develop design alternatives.
4. Develop optimum designs and verify designs with simulations.
5. Verify the design with pilot runs and implement the final production process.

A Six Sigma innovation involves professional quality management functions related to leadership levels and martial arts ranking using the following structure:

- **Executive leadership** includes the chief executive officer (CEO) and other members of top management. They are responsible for creating a Six Sigma implementation plan. The executive leadership also gives freedom and resources for other management functions to explore new ideas and improvements.
- The executive leadership draws from upper management to establish the **champion** level. Champions take responsibility for Six Sigma implementation across the organization and act as mentors to black belts.

- **Master black belts** are Six Sigma coaches who assist champions and guide black belts and green belts. Master black belts perform statistical tasks and guarantee consistent application of Six Sigma functions across departments.
- **Black belts** work full time under master black belts to apply Six Sigma to specific projects.
- **Green belts** operate under the guidance of black belts and implement Six Sigma along with their other job responsibilities.
- **Yellow belts** are typically production people trained in the use of Six Sigma management applications, and they work with black belts throughout the project stages.

In the United States, Six Sigma certification for green and black belts is offered by the **Institute of Industrial Engineers (IIE)** and by the **American Society for Quality (ASQ)**. The IIE ([www.iienet.org](http://www.iienet.org)) is a professional society dedicated to the support of the industrial engineering profession and individuals involved with improving quality and productivity. The ASQ ([www.asq.org](http://www.asq.org)) is a global community of quality control experts dedicated to the promotion and advancement of quality tools, principles, and practices. Motorola offers global certification for green belts, black belts, and master black belts. There are many other organizations and companies that offer certification. You can find these organizations by searching Six Sigma on the Internet.

## Concurrent Engineering (CE)

**Concurrent engineering (CE)** is an integrated approach to design, production, and customer service that emphasizes the advantages of simultaneous, or concurrent, product design by employing individuals from various areas of the business in the up-front concept and design phase, with special emphasis on customers and their needs. The focus is on all aspects of the design simultaneously, which is accomplished by the integration of people, processes, standards, tools, and methods to achieve a quality solution to the design problem.

## Life Cycle Engineering

**Life cycle engineering** is also referred to as **product life cycle management (PLM)**. The concept behind life cycle engineering is that the entire life of a product should be evaluated at the beginning of the design process. The optimal design cannot be achieved unless performance, start-up and sustaining costs, reliability, maintainability, disposability, and market trends are addressed up front. Built into this design process is the consideration for product replacement time lines, withdrawal and disposal of the product from the market, and product replacement.

## Integrated Product Development (IPD)

**Integrated product development (IPD)** is the process by which the product is designed and developed to satisfy all the conditions the product encounters in its product life. Evaluating all

the factors that impact the design during the product life at the initial design phase increases the likelihood that unforeseen circumstances will not accumulate and damage the product's longevity in the marketplace.

## Knowledge-Based Engineering (KBE)

**Knowledge-based engineering (KBE)** is the use of computer models to simulate the best-known engineering processes. Typically, KBE is used by creating a set of engineering data. This data comprises components such as CADD data, manufacturing data, tooling data, and structural information. This data is then used in an integrated manner to develop a more detailed and comprehensive design plan. The inclusion of so much information allows for better analysis and evaluation throughout the process.

## Total Quality Management (TQM)

**Total quality management (TQM)** is a philosophy that calls for the integration of all organizational activities to achieve the goal of serving customers. It seeks to achieve this goal by establishing process standards, maximizing production efficiency, implementing quality improvement processes, and employing integrated teams to effectively design customer-driven products. TQM strives to eliminate all non-value-added activities in the production process and to achieve satisfaction of all its customers, both internal and external.

## AN ENGINEERING DESIGN PROCESS

Previously, you were introduced to the importance of the driving forces behind the engineering design process, such as market trends, customer desires, competitive pricing, quality, and technology. You also reviewed several different engineering design models used in industry. Bringing new or revised products to market quickly is critical in a competitive world. As a result, the design process has evolved into a system that focuses on quality, speed to market, and the elimination of waste in the system. Although getting a product to market fast is necessary, the actual length of time it takes to go from an idea to a final manufactured product on the assembly line varies with each company, its products, and its marketplace. If the driving force is to make a profit, then the company must be very responsive to customer needs. This process also depends on the engineering design model used. For example, using the concurrent engineering model might reduce time to market by 40%, in some cases, over the traditional model.

The following discussion gives you an insight into an engineering design process that is widely used and focuses on how one company in the manufacturing industry successfully uses the process. The process normally follows a step-by-step approach that can be modified as needed to meet specific objectives. It can take anywhere from one week to ten years to bring a new product to market. The amount of time required depends

on the complexity of the product, the company, its flexibility, the maturity of technology, the company's commitment, product design, and documentation requirements.

Today's industry involves a **cross-functional team approach** in which everyone is involved in cooperation as a team rather than a situation in which one person or group does something and then passes the completed portion on to the next person or group. The entire process from a design idea to final production goes much more smoothly if everyone communicates about and is involved with the product development process.

The following information introduces you to marketing, the project leader, and a variety of other people who work to help ensure the success of a design from idea through production. The **product description and business case** is created by **marketing**. After thorough market research, marketing typically prepares the product description and business case for approval by management. It is important that the new product fits within the goals and long-term strategy of the corporation. The product description and business case is a formal document that specifies the features, pricing, and costs of a new product. This document communicates the customer needs to engineering and provides guidance for the actions of the engineering team. Marketing gathers input from customers in the target market and also from departments such as purchasing, engineering, and sales. The person who takes charge of the project after marketing releases a product description and business case is the **project leader**. The project leader coordinates across the functions within the company's different disciplines, such as purchasing, quality control, manufacturing, and marketing as the project moves from design through manufacturing. The project leader does not generally have other departments that report directly to him or her, so it is important for the project leader to develop good working relationships that achieve cooperation and share a common objective. It is also to the benefit of all groups and people involved to have a quality rapport with the project leader for the good of the project and the company.

You can use most of the concepts covered in the following discussion when designing your own ideas or to complete the design projects at the end of this chapter. Some of the principles are highly technical in nature and are influenced by specific company activities, products, and objectives. You may not be able to use some of the information in your designs now, but you should be aware of the concepts for future applications when you work in industry.

Much of the following discussion was created from information obtained from Milwaukee Electric Tool Corporation. Paralleling the general design process information is the examination of a case study on a new product design from concept through production. The product used for this design sequence example is the Milwaukee Electric Tool Corporation's V28™ Lithium-Ion Sawzall® reciprocating saw shown in Figure 25.3. In addition to the acknowledgment provided in the Preface, special thanks are given here to David P. Serdynski, Senior Design Engineer, and Troy Thorson, Design Engineer, with Milwaukee Electric Tool Corporation, and their colleagues who supported this content.



**FIGURE 25.3** The V28™ Lithium-Ion Sawzall® reciprocating saw. Courtesy Milwaukee Electric Tool Corporation

## Project Portfolio Management

A **project portfolio** is a compilation of all potential new projects that are under consideration for implementation. **Project portfolio management** is the methodology that management uses to select projects for execution and the order in which the projects are completed. Project portfolio management is also used to determine the number of projects a company puts into action at any one time with the available resources. Several elements go into managing the project portfolio, including input from groups within the company and market research. Project portfolio management allows the company to prioritize new projects and determine which projects to eliminate or save for implementation in the future. Project portfolio management helps the company identify what items are sensitive to the outcomes of business decisions. Project portfolio management can be supplemented using techniques from **operations management**, also known as **management science**, which are the mathematics and optimization techniques used to prioritize the project portfolio. Management science uses a mathematical process in which a business or engineering solution is simulated to determine optimum results. The participants determine the independent variables that effectively simulate reality and the output as an optimized prioritization of projects. These mathematical processes are based on quantitative data rather than emotional opinions or political agendas. For example, determine the value and attractiveness to the company to evaluate several different products that you want to take to market within the next year, then you determine the value or attractiveness of each as inputs that your company feels are correct to evaluate the projects under consideration.

## Research Activities

Most of the accomplishments achieved in modern industry are the result of extensive research, planning, and evaluation. The following information describes the two basic types of research, including advanced research and existing product research.

### Advanced Research

A competitive edge in modern industry is often established through **advanced research**. Advanced research is used to determine if there are areas of technology currently not used.



**FIGURE 25.4** The complete line of V28 Lithium-Ion powered portable electric tools. *Courtesy Milwaukee Electric Tool Corporation*

This unused technology can be commonly found in some applications while it is untapped or currently unattainable in others. Unused technology also can be completely new. In either case, new technology is something the company strives to develop. The goal of advanced research is to create a product no one else has or a technology no one else can make work. Advanced research also involves working with specific partners in industry to develop a technology that exceeds anything currently available. The desired results can put the company in a position of being the only one who has this technology available to sell to customers. This also makes very high barriers for other companies to get into the same market.

An excellent example of effective advanced research is the Milwaukee Electric Tool Corporation V28 Lithium-Ion (28 volt) battery technology. Cordless electric power tools have been available for years, but none of them have used the superior technology of the lithium battery. Other industries have used lithium ion technology, such as cellular phones and laptop computers, but this technology has not previously been used on power tools. This example shows how

advanced research has resulted in the following gains in this technology:

- Up to twice the run time of 18 volt tools.
- Delivers up to 40% to 50% more power.
- Provides 28 volts of power at the weight of 18 volt batteries.

Figure 25.4 shows the complete line of V28-powered portable electric tools.

### Existing Product Research

A common approach to the design of new and updated products is based on **existing product research** and is also called **benchmarking**, which is discussed later. Existing product research involves the redesign of a current product. To be successful in this process, it is important to know everything about the function of the existing product and evaluate how it is used. It is also critical to look at competitive products and carefully compare their features and operation to the product being redesigned. Redesign can involve use and modification of features

available in other industries. Existing product research can also involve modernization of a product with new features such as ergonomic design, shape, and color.

## Project Termination

The project team has the responsibility to stop the project at any time if it becomes unprofitable or if market conditions change. A project can get terminated based on new market information, new competitor releases, and changes in company direction or resources. Termination of a proposed project should occur as soon as obstacles mount and belief that future efforts would be a poor use of company resources. A decision to continue or stop a project is made by a broad cross section of people who provide information to the project team. The project can be canceled if feedback indicates continuing the project is a poor idea. Stopping a proposed project can be a strategic business decision or a cost savings issue.

## THE PHASE GATE DESIGN PROCESS

Modern industry uses a variety of processes to help ensure success when creating a new product design. Although there is no guarantee of achieving success, it is important to do the required research, survey customers, and make smart business decisions based on all available information and technology. The **phase gate design process** helps to prevent failures in new product development. Past experiences help a corporation identify the correct system of checks and balances leading to successful projects. The phase gate design process is a practice that makes sure you get the right work done at each phase of design before you are able to go to the next phase. The idea involves an imaginary gate, at the end of each phase, that must be opened before you can continue. You must complete certain tasks in order to open each gate. The project can be terminated before you pass through the next gate if specific criteria are not met. The costs associated with continuing a project rise after each phase gate. Therefore, it is important to discontinue a project as soon as it becomes unattractive. Figure 25.5 shows a flowchart that provides the phases and gates of the phase gate design process. The *YES* indicators in the flowchart represent paths leading to success. Sometimes a *YES* path allows the process to continue as the result of a deficiency correction in the process. The *NO* indicators mean that there is a problem that needs to be corrected in the previous step. *NO* paths can lead to corrections, which result in a revised *YES* path, or they can lead to additional *NO* paths where more work is required to correct a problem. If deficiencies cannot be corrected, then *NO* paths can lead to a project's cancellation.

### Phase 1: The Concept Phase

The first phase of the design process is the **concept phase**. The concept phase begins after a marketing team creates the previously discussed product description and business case. In this phase, multiple concepts are typically explored and evaluated, leading to the selection of the best solution. In this phase, multiple concepts are typically explored and evaluated, leading to the selection of the best solution.

Customer satisfaction is critical to the success of all products and is specifically addressed during the concept phase. There are a variety of ways to determine customer satisfaction, depending on the specific product, the size of the customer base, and the desired results.

A **project plan** is also created by the project leader, which issues a schedule that communicates the anticipated implementation timeline for the project. The project team is also formed at this time. Team members are given their assignments, and expectations are established. A major benefit of this practice is to ensure all critical tasks are identified and accounted for.

## Concept Activities

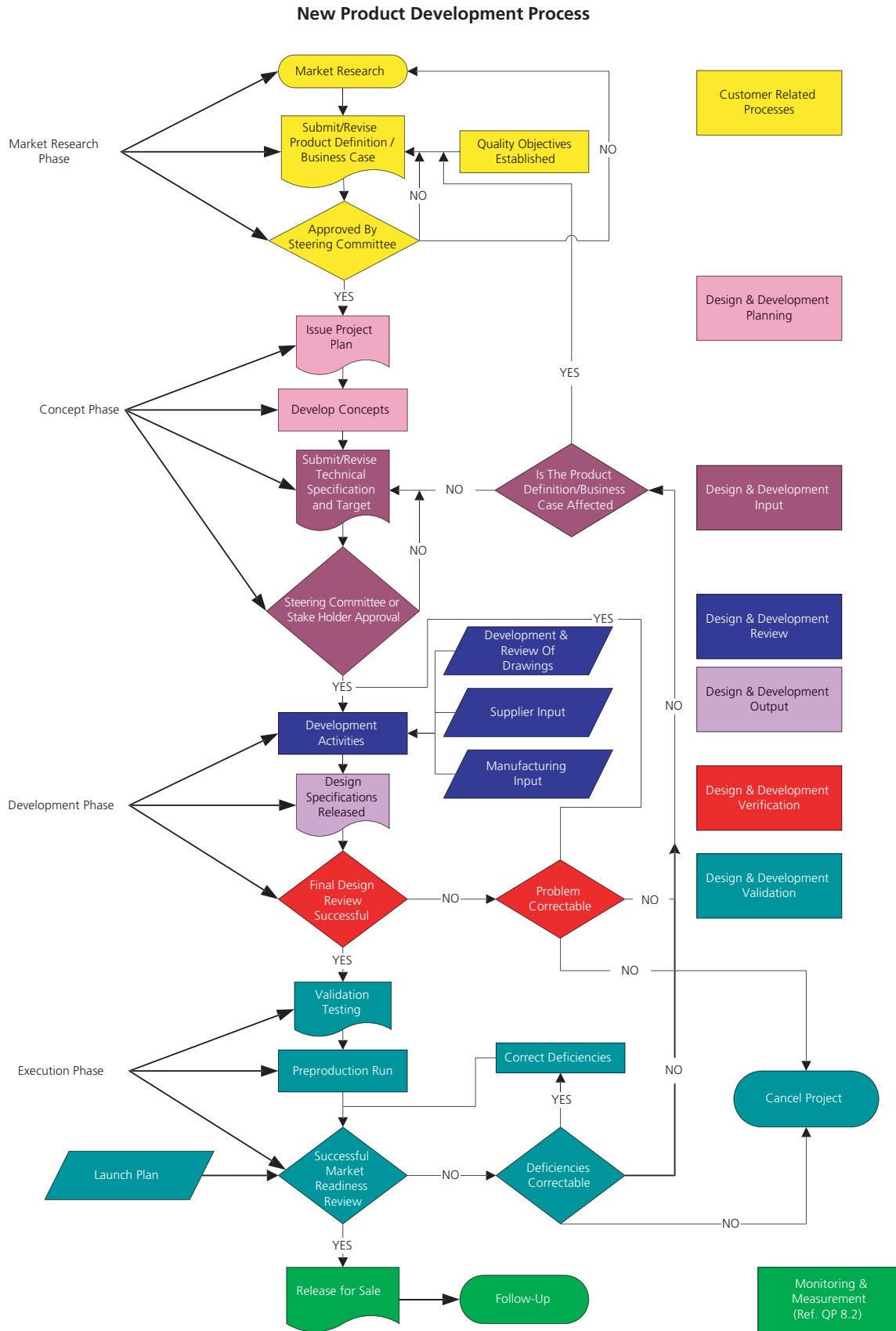
**Industrial Design in the Concept Phase**—The concept team is primarily made up of industrial designers, designers, and engineers. **Industrial design (ID)** is a team of highly skilled and creative people who have extensive product knowledge and experience. The ID team has the flexibility of being extremely creative, and their knowledge of engineering and production processes is essential. The ability to be creative and work within engineering, manufacturing, and cost constraints is a key to having a quality industrial design group.

ID tools include pencil, paper, markers, and computers with specialized hardware and software. Traditional pencil and paper and color markers are commonly used in a creative and artistic manner for many initial design concept sketches. Basic drawing tools still allow for the most intuitive and rapid visualization of multiple concepts.

The computer and a peripheral pressure-sensitive tablet are also used by the industrial designer as shown in Figure 25.6. The industrial designer uses a light touch for layout and harder pressure for solid lines and forms when working on the electronic tablet. A computer stylus and tablet simulate the feeling of pencil and paper, providing a direct relationship between the designer's brain and the sketch. The designer starts by drawing shapes and then rendering as needed, including highlights for depth and appearance. Modifying the computer-generated design sketch is easy and efficient, especially with the aid of commands such as *Undo*, which can be used as often as needed to remove unwanted work. Different software applications have different commands for this activity. The ID team uses a variety of software applications, but the industrial designers with Milwaukee Electric Tool Corporation prefer Alias® Sketchbook™ Pro ([www.autodesk.com](http://www.autodesk.com)), which provides an almost natural feel and appearance, according to Scott Bublitz, an industrial designer.

The process begins with a meeting held to start the project. Marketing, the project team, and industrial designers attend this meeting. The initial direction is communicated to the industrial designers along with any research that has been done on existing products and the target market. Engineering communicates the overall approach planned for production. The concept design phase begins following this meeting. Concept design also involves further research into the product and observation of similarly existing products in use. This is also the point at which ergonomics are researched for the given product.





Courtesy Milwaukee Electric Tool Corporation

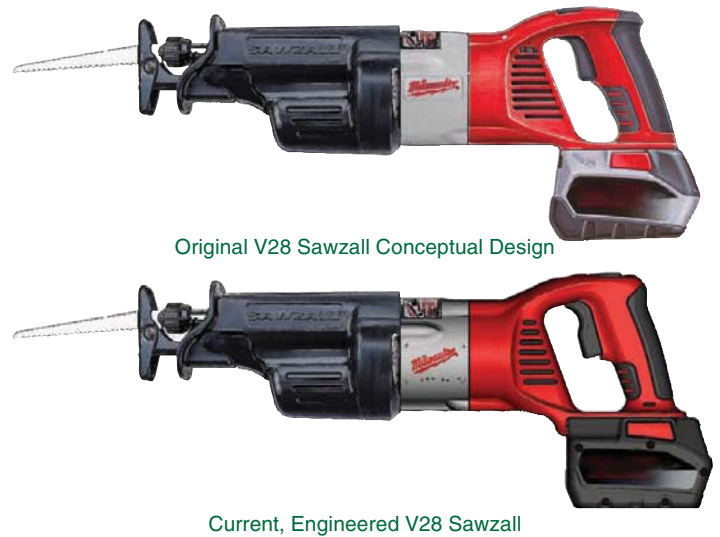
**FIGURE 25.5** A flowchart providing the phases and gates of the phase gate design process.



**FIGURE 25.6** The computer and its peripheral pressure-sensitivity tablet are also used by today's industrial designer. *Courtesy Milwaukee Electric Tool Corporation*

The consideration of ergonomics is very important, especially when the product is a handheld tool, such as the design example used throughout this discussion. Sketches are then created to illustrate various layouts in multiview, or pictorial, features and styling. Usually, six to 12 idea renderings are created in the concept design phase. These are then presented to marketing and engineering for their input and assistance in narrowing down the concepts to one or two desired possibilities. This is sometimes as easy as picking a concept that everyone likes, but often it involves combining features of multiple concepts to create a hybrid that satisfies the design intent. This is also a good checkpoint for engineering to examine any issues that may be inherent in a specific design or approach. This allows the industrial designer to make needed adjustments or corrections in the process rather than having to clean up a mess later as an afterthought. Next, the industrial designer begins concept refinement, where final renderings and multiple views are created. This is also usually the time when the creation of foam mockups is helpful, although this sometimes happens even earlier. The refined concept or concepts are then presented again to engineering and marketing. Once everyone is in agreement on a concept direction, CADD models are created either by industrial designers or CADD designers. A comparison between the industrial design and the modified CADD design for the V28 Sawzall reciprocating saw is shown in Figure 25.7.

As discussed earlier, the development of a concept involves a cross-functional team approach in which everyone is involved in cooperation as a team rather than a situation in which one person or group does something and then passes the completed portion on to the next person or group. The entire process, from a design idea to final production, goes much more smoothly if everyone agrees about and is involved with what is being done during every step. For the cross-functional team approach to work, engineering parameters are communicated at the initial meeting, and concepts challenging these are assessed by



**FIGURE 25.7** A comparison between the industrial design and the modified CADD design for the V28 Sawzall reciprocating saw. *Courtesy Milwaukee Electric Tool Corporation*

engineering in process. Industrial designers then work with engineers to solve the problem in a manner that pleases engineering, industrial design, and marketing. In this way, industrial design essentially becomes the cross-functional liaison between what marketing wants and what engineering can accomplish.

**Quality Function Deployment (QFD)**—Information from customers is a key element of the concept phase, and one method of determining the **voice of the customer (VOC)** is by using a system known as **quality function deployment (QFD)**. QFD is a product and service planning process that starts and ends with input from customers. Customer feedback is the driving force behind the development requirements for a new or revised product or service. QFD is generally added to the process, depending on the scope of the project and the need for customer response. A team of marketing and research professionals generally come together to implement the QFD process, but the method can be done by one person, depending on the complexity of the task. The format of the QFD process is designed to remove many of the barriers found in organizations, including emotions, and unsupported perceptions about the way products or services are developed. When the QFD process works as intended, the customer knowledge available in the marketing department is coupled with the product knowledge found in the engineering department. Companies deciding to use QFD must listen to what customers want and investigate how to respond to customer needs. QFD is important to use when companies take the creation of new or revise products and services seriously. It is essential to use a process such as QFD for the following reasons:

- It is difficult to be impartial when you do product planning for the company that employs you.
- The process is mechanical rather than emotional or political.
- It helps to highlight customer desires.
- It uses an analytical approach to rank customer wishes.

It is sometimes preferable to hire an outside firm to do market research so that the company is isolated from the research and favoritism is reduced as much as possible. Other times, the expertise held within a corporation make it better able to complete this research directly. Proper use of customer research allows the company to seek the truth rather than make the results say what may be preferred. Customer input can be established through one or more of the following means:

- Mail or phone surveys or questionnaires.
- Telephone or field interviews with customers.
- Product clinics at retailers or by customer invitation.
- Focus groups made up of key customers, retailers, or wholesalers.
- Listening to customer complaints and recommendations from feedback on your Web site or through other correspondence.
- Evaluating warranty service documentation.

QFD can be done before the product description and business case so it can be used as part of the product description and business case. Projects at the end of this chapter allow you to design products and do your own customer research.

**The Design Specification**—During the concept phase, technical specifications and performance targets are established. These give guidelines to the project team and help identify what constitutes a successful design. Various factors are considered when developing the **design specification**, including, but not limited to, competitive product investigation, customer research, expected life or warranty, and certification requirements. QFD can be used as a tool to help translate customer needs into the design specifications. The design specification is a document typically made for each project with requirements such as:

- Dimension.
- Weight.
- Materials.
- General shape.
- Power requirements.
- Voltage requirements.
- Amperage specifications.
- Product life and durability requirements.
- Required agency approvals.
- Performance requirements.
- Included and optional accessories.
- General and special features.
- Environmental factors.

## Gate 1: Passing the Concept Phase Gate

Throughout the concept phase, all of the design possibilities are investigated and a desired product concept is selected. Mockups and cost estimates are made to aid the decision process. After the design team has completed its investigation and arrived at a selected concept, a **concept review** is held to officially approve the concept and to get a **go** decision to move into development. The concept review team is a group of people who represent engineering, marketing, quality control, manufacturing, and management.

## Phase 2: The Development Phase

When the concept phase is successfully completed, it is time to start the **development phase**. In the development phase, a fully functioning prototype model is made that operates at the desired quality level. Prototype parts can be machined or created using rapid prototyping. Parts are assembled into the desired product and then tested to determine if the design meets specific metrics. **Metrics** is a term frequently used in engineering to stand for product requirements such as weight, dimensions, operation performance criteria, comfort, or other physical factors included in the design. For example, a requirement specified in a product description and business case can be for a product to weigh a maximum of five pounds. Using this example, if the product weighs five pounds or less, the design is successful based on the weight metric; if the product is overweight, however, the design or the specification must be modified. Another example of metrics might be a functional quantity that the product must meet when in use, such as a portable battery-operated automated screwdriver that must place 500 screws per battery charge. During capacity testing, if the tool performs at only 300 screws per battery charge, then something needs to be done to improve the performance by designing a more efficient mechanism or a better battery. The testing performed on the functioning prototype can be robotic or human testing to determine if the proposed product meets a number of use cycles and is good enough to continue further development.

### Creating a Functioning Prototype and Establishing Purchase Parts

Part of the development phase includes making prototypes and working models that allow testing and confirmation with marketing, sales, and customers that the product is appropriate. A functioning prototype is built to verify product performance and to finalize part tolerances. Figure 25.8 shows a rapid prototype part for the V28 Sawzall reciprocating saw.

The design might have to return to the concept phase for reevaluation if it is found that some aspects of the design do



**FIGURE 25.8** A rapid prototype part for the V28 Sawzall reciprocating saw. Courtesy Milwaukee Electric Tool Corporation

not perform as intended or if manufacturing processes are estimated to be too costly.

After the functioning prototype has been built and tested, drawings are created for assembly of all components. Parts made by others are called **purchase parts**. Purchase parts and purchase part drawings are discussed in Chapter 15, *Working Drawings*. Figure 25.9 shows a purchase part drawing. These drawings define the critical performance functions, dimensions, and tolerances, and they are used by suppliers to provide price quotes. The purchasing department identifies possible suppliers, gets quotes, and then makes the final supplier selections. Parts made **in-house** go through a similar process in cooperation with manufacturing engineering. *In-house* refers to any operations conducted inside the company. At this time, the quality engineering department generally reviews all drawings to ensure that the parts can be inspected in production.

### Checking Intellectual Properties

In addition to creating a functioning prototype, other concerns need to be resolved, such as **intellectual properties**. As described

on the World Intellectual Property Organization Web site ([www.wipo.int](http://www.wipo.int)), intellectual property is divided into two categories: **Industrial property** and **copyright**. Industrial property includes inventions (patents), trademarks, and industrial designs. Copyright includes literary works such as novels, poems, plays, films, and musical works, and artistic works such as drawings, paintings, photographs, sculptures, and architectural designs. Intellectual properties have to be investigated to be sure the design does not infringe on something that is already on the market or will be on the market soon. A popular form of intellectual property investigation is called **patent research**. Patent research is done to ensure there is no infringement of an existing patent. It is essential to be sure there is no violation of an existing patent before significant investment is made in tooling and manufacturing equipment. **Invention disclosure** is the process that establishes an idea with a written and dated document that secures the design as yours. This is followed by filing a patent application. This process is critical, because competitors are also doing the same types of exploration with their market research, making it possible that they can come up with the same design at approximately the same time. It has

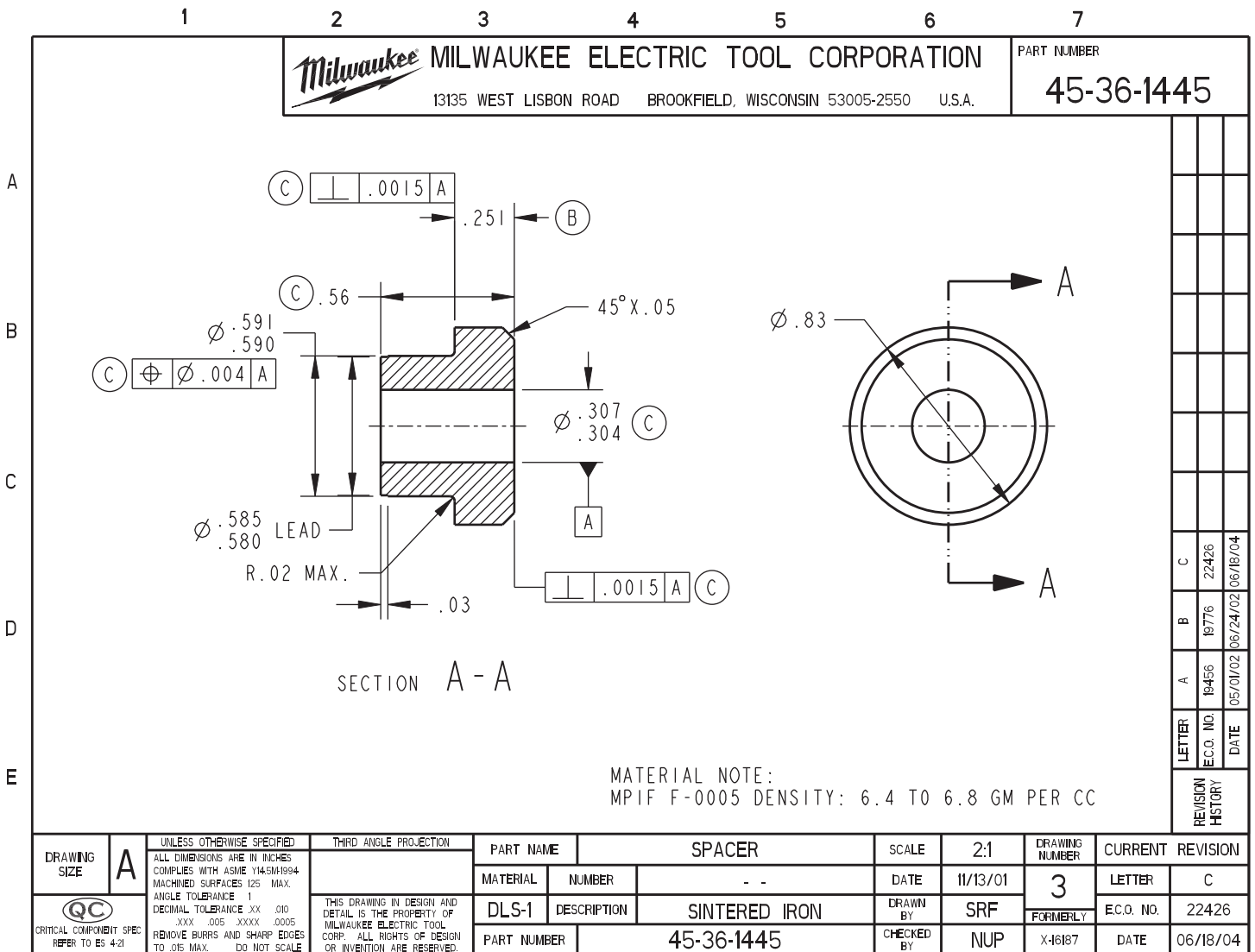


FIGURE 25.9 A purchase part drawing. Courtesy Milwaukee Electric Tool Corporation

been known to happen that the same design is submitted for a patent within days of a previous submittal. Intellectual property and workplace ethics were also discussed in Chapter 1, *Introduction to Engineering Drawing and Design*.

### The Product Bill of Materials in the Development Phase

A **product bill of materials** is created to establish the final product cost and to help organize the manufacturing process. Capital that needs to be spent to make parts in production, such as tooling, die, and pattern costs, also needs to be determined at this time. If cost or any other process is unacceptable, then the project can be delayed until the situation is improved. For example, if a product is estimated to be over budget, the project leader may be responsible for reducing the cost before proceeding. Review Chapter 15, *Working Drawings*, for a discussion and examples of parts lists and bills of material.

### Failure Mode Effect Analysis (FMEA)

Once the development phase is underway, the design team initiates other necessary activities. It is important for an engineering design to function under all expected conditions and within all tolerance ranges. A tool used to help achieve this is called **failure mode effect analysis (FMEA)**. FMEA is a technique used to determine possible failures and ways to eliminate them. If a failure cannot be eliminated, then the design should minimize its impact on the product. The FMEA is also used to prioritize issues. For each potential failure, the following issues are addressed:

- *The potential effect of the failure:* What events will take place if this failure happens?
- *The severity of the failure:* Severity can range from loss of life to minor irritation. More severe problems must be addressed first.
- *The probability of occurrence:* Failures most likely to occur are addressed first.
- *The probability of not detecting the failure until serious damage is done:* An example of this would be fatigue cracks on an airplane wing. A crack detected while the plane is on the ground is less harmful than a rupture while in midflight. Hard-to-detect failures get priority.
- *Potential failure causes and mechanisms:* It may take considerable time and testing to identify the main causes.
- *Current controls and procedures:* What controls and procedures are currently in place to eliminate or mitigate the failure?
- *Recommended actions:* What future actions need to be taken?
- *Verification:* Is evidence available that the problem has been addressed? Verification can come from laboratory testing, field tests, or the performance of a similar product over time.

Companies commonly identify special product characteristics with an appropriate symbol on an FMEA worksheet. These special characteristics are normally items that affect regulatory compliance, such as features that should be given consumer warnings or special process controls. Figure 25.10 shows the FMEA worksheet for the V28 Sawzall reciprocating saw.

Partial Sawzall Design FMEA

Function	Potential Failure Mode	Potential Effect(s) of Failure	sev	Potential Failure Cause/Mechanism	Prob of Occur	Current Design Controls	Prob of Not Detecting	Recommended Actions	Action Status	Verification
Cut nail embedded wood	Cut too slow	Customer dissatisfaction	H	Not enough power in motor	L	Use proven motor	L	None		Verified by testing and performance of previous models
Cut nail embedded wood	Cut too slow	Customer dissatisfaction	H	User using wrong cutting speeds	H	SAWDUST helpline, distributor training, and available user training	L	Review customer feedback records to see if current training is effective	Sales reps contacted	Analysis to date: users report improved results after training
Plunge cut	Battery hits workpiece before achieving approach angle	Customer dissatisfaction	H	Not enough space provided by design	L	Design provides sufficient battery clearance	L	None		Annex testing verifies that battery does not interfere with plunge cuts at several different angles

For severity (sev), probability of occurrence, probability of not detecting - low is better, high is worse

FIGURE 25.10 FMEA worksheet for the V28 Sawzall reciprocating saw. Courtesy Milwaukee Electric Tool Corporation

## Computational Dynamics and Finite Element Analysis in the Development Phase

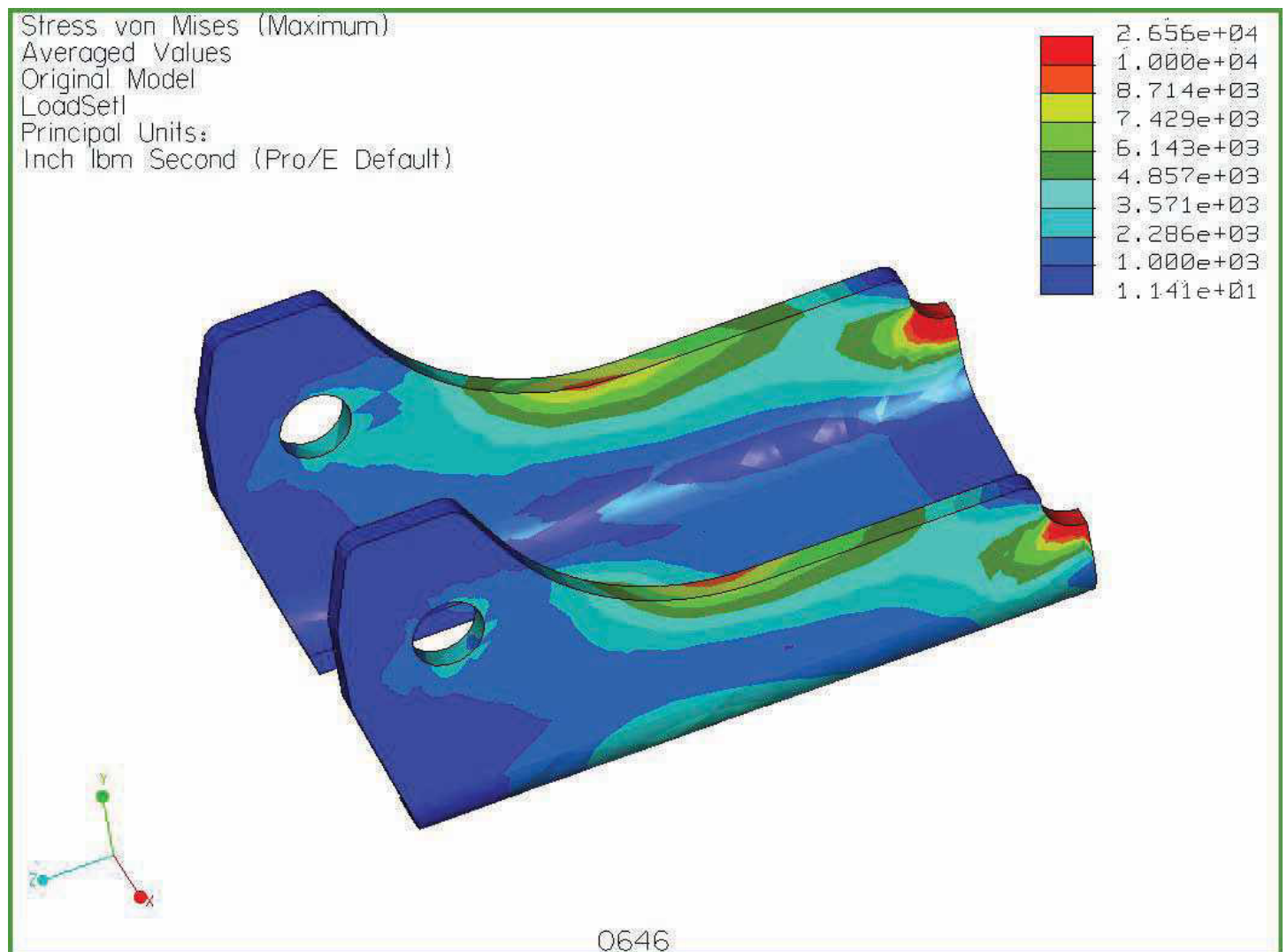
A variety of software products are available for mathematically analyzing features such as gear, cam, and bearing design. **Finite element analysis (FEA)** software programs allow for mathematical solutions to structural and thermal problems. FEA consists of a computer model of a material or design that is stressed and analyzed for specific results. It is used in new product design and existing product modification. Using FEA, a company is able to verify that a proposed design is able to perform to desired specifications, including tolerances and fits, before manufacturing or construction. Two basic types of FEA are 2-D modeling and 3-D modeling. Two-dimensional modeling allows the analysis to be run on most computers, but it generally provides less accurate results.

In comparison, 3-D modeling results in better accuracy, but high-end FEA programs must be run on powerful computers. Many parametric modeling packages have stripped down FEA applications that can be run on most PCs. When using an FEA

program, the engineer provides a variety of mathematical functions to make the product or structure perform under desired stress conditions. Figure 25.11 shows a 3-D model being subjected to simulated tests and stress analysis.

Another benefit of FEA is its use in bench marking, which means that you analyze the product where you start, thereby establishing the bench mark. Then when you go through redesign or make desired changes, you reanalyze to determine the difference from the bench mark condition to the revised condition.

An example of an FEA software program is TK Solver, provided by Universal Technical Systems, Inc. ([www.uts.com](http://www.uts.com)). This software allows you to perform the finite element analysis functions previously discussed and also a process referred to as **back solving**. For example, when you are designing a bearing, you input data, and software determines the force it takes to press fit the bearing on a shaft. The inputs for this operation include the shaft size, hole size, and material specifications. In reverse, you provide the force data and the software back solves by calculating the design criteria, such as shaft size, hole size, and material.



**FIGURE 25.11** A 3-D model being subjected to simulated tests and stress analysis. *Courtesy Milwaukee Electric Tool Corporation*

## Design Documentation to Release Documentation

The following discussion provides a typical example of the transition from **design documentation** to **release documentation**. As used here, the term **release** means that documentation has made the transition from the development phase to the execution phase or changes in documentation that occur between revisions of the product. The execution phase is covered later in this chapter. Although companies can have different part numbering systems, there are similarities. For example, all sketches and drawings in the development stage might be created with prototype part numbers using a P prefix to designate the part is a prototype. When the product passes through the development stage, prototype part numbers change to release part numbers and the P prefix changes to represent the final product. Companies use different part numbering systems, but a common format can have three elements, such as 31-50-0019. In this example, the prefix 31 represents the product code, the 50 relates to the assembly or subassembly, and 0019 is the specific part number. Most companies have a control database for all files, including prototype, release drawings, and revisions. This system can be created to make sure all revisions are backward compatible and to determine which products can be serviced with which parts. **Backward compatible** means that new parts also function in previously manufactured versions of products. For part and product tracking, everything in the CADD system is controlled by **product release level**. This means that the CADD system allows the company to design and draw parts and to control changes in releases.

Finished component assembly drawings are created for each product and its components. The set of working drawings can include a 3-D or 2-D assembly drawing, or both, and subassembly drawings, 2-D detail drawings, specifications, wiring drawings, and assembly instructions. The 3-D assembly drawing, service parts list, assembly notes, 3-D wiring diagram, and wiring specifications for the V28 Sawzall reciprocating saw are shown in Figure 25.12. Refer to Chapter 15, *Working Drawings*, for information on the variety of detail and assembly drawings and for part lists used in industry.

## Gate 2: Passing the Development Phase Gate

When the development phase is complete as desired, the design review committee evaluates the product development through the current status before the design can pass through the product development phase gate. If the product development is approved, the committee certifies that there is enough confidence in the design to continue. There may not be 100% certainty, but enough has been done to show that the proposed product is appropriate and that reasonable success has been provided from prototype testing. This testing ensures high confidence that all requirements of the design specification have been met. The execution phase starts when the design review committee gives final approval of the development phase.

## Phase 3: The Execution Phase

The **execution phase** begins when the company is ready to invest in the final production of the product. This investment can include capital acquisitions for machinery, tooling, patterns, molds, and assembly equipment. This process also includes the coordination of all manufacturing activities, such as setting up production lines and purchasing components needed in preparation for the first preproduction build, which is discussed later in this section.

Once engineering drawings are released to the vendors and in-house manufacturing, **schedule tracking** becomes an important project management function. Schedule tracking establishes a system that prioritizes and organizes the work to be done through manufacture, assembly, packaging, and shipping of the product. This scheduling includes defining all tasks, applying resources where needed, assigning personnel, and establishing desired outcomes.

When samplings of the parts come back from the outside vendor, they are carefully inspected to ensure they meet design requirements for elements such as dimensional tolerances, functionality, weight, color, and other required characteristics. The company's quality engineering department generally confirms that the suppliers have met design dimensions by carefully measuring and verifying the parts submitted.

Once all parts have been inspected and are confirmed to be within specifications, a preproduction build is performed. In a **preproduction build**, a limited number of products are manufactured and assembled for the purpose of validating the manufacturing process and final product conformance. Additional testing is done on the preproduction build to determine how the first products off the production line meet the established design specification. This allows the company to make needed adjustments before a full production begins. The preproduction build is also used for required regulatory approvals.

**Regulatory Approvals—Regulatory approval** is part of the execution phase in which established institutions, normally not-for-profit and for consumer protection, test the product with varying levels of intensity, depending on their purpose. Examples of tests performed include:

- Impact testing to determine the durability of the product during use or when dropped.
- Flame retardant ability to determine if the product resists fire or self-extinguishes when on fire.
- Dielectric tests to verify insulation systems.
- Vibration testing for operational smoothness and related ergonomics.
- Sound level testing.

The Underwriters Laboratories (UL) is probably the most commonly recognized certification agency. The American National Standards Institute (ANSI) is another.

**The Production Sample Inspection**—Random samples are commonly taken from the preproduction build for inspection. The quality engineering department typically coordinates this

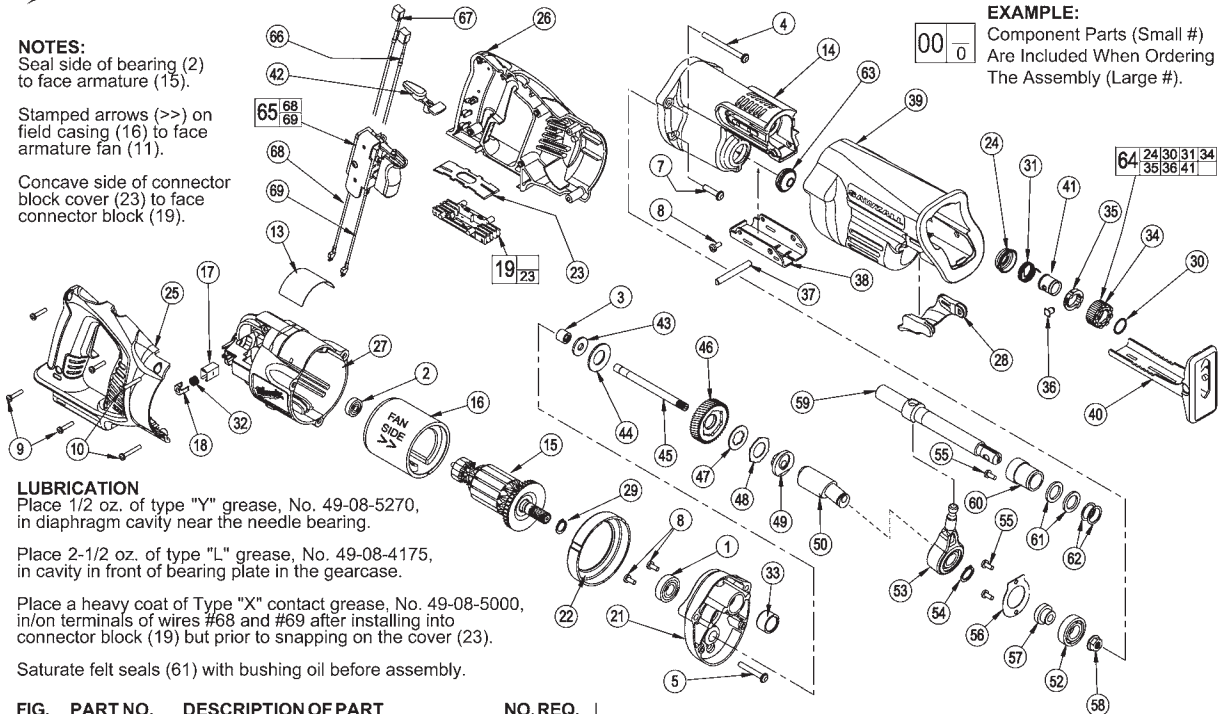


SERVICE PARTS LIST

BULLETIN NO.  
54-40-7001

SPECIFY CATALOG NO. AND SERIAL NO. WHEN ORDERING PARTS		REVISED BULLETIN	DATE
CORDLESS SAWZALL®		54-40-7000	April 2005
CATALOG NO. 0719-20	STARTING SERIAL NO. A56B	WIRING INSTRUCTION SEE REVERSE SIDE	

**NOTES:**  
Seal side of bearing (2) to face armature (15).  
Stamped arrows (>>) on field casing (16) to face armature fan (11).  
Concave side of connector block cover (23) to face connector block (19).



**LUBRICATION**  
Place 1/2 oz. of type "Y" grease, No. 49-08-5270, in diaphragm cavity near the needle bearing.  
Place 2-1/2 oz. of type "L" grease, No. 49-08-4175, in cavity in front of bearing plate in the gearcase.  
Place a heavy coat of Type "X" contact grease, No. 49-08-5000, in/on terminals of wires #68 and #69 after installing into connector block (19) but prior to snapping on the cover (23).  
Saturate felt seals (61) with bushing oil before assembly.

FIG.	PART NO.	DESCRIPTION OF PART	NO. REQ.
1	02-04-0719	Ball Bearing	(1)
2	02-04-5130	Ball Bearing	(1)
3	02-50-2150	Needle Bearing	(1)
4	05-88-0302	K50 x 60mm Washer Hd. PT Screw	(2)
5	05-88-8309	K50 x 35mm Washer Hd. PT Screw	(1)
7	06-82-5363	8-32 x 1 Washer Hd. Taptite T-20 Screw	(2)
8	06-82-7253	8-32 x .38 Taptite T-20 Screw	(3)
9	06-82-7261	6-19 x .687 Slotted Plastite T-15 Screw	(4)
10	06-82-7276	6-19 x 1.00 Slotted Plastite T-15 Screw	(2)
13	12-20-0719	Service Nameplate Kit	(1)
14	28-14-0999	Gearcase	(1)
15	16-01-2121	Service Armature	(1)
16	18-01-2120	Service Field	(1)
17	22-20-0860	Brush Tube	(2)
18	22-32-0400	Brush Spring Clip	(2)
19	22-56-0975	Connector Block Assembly	(1)
21	28-28-0719	Diaphragm	(1)
22	31-05-0719	Baffle	(1)
23	-----	Connector Block Cover	(1)
24	31-15-0511	Spring Cover	(1)
25	31-44-0718	Right Handle Half	(1)
26	31-44-0719	Left Handle Half	(1)
27	31-50-0019	Motor Housing	(1)
28	31-52-0090	Shoe Release Lever	(1)
29	34-60-0920	External Retaining Ring	(1)
30	34-60-3680	Retaining Ring	(1)
31	40-50-0161	Torsion Spring	(1)
32	40-50-8840	Brush Spring	(2)
33	42-24-0620	Rear Spindle Bearing	(1)
34	42-50-0076	Front Cam	(1)
35	42-50-0077	Rear Cam	(1)
36	44-60-0626	Lock Pin	(1)
37	44-60-1635	Shoe Pin	(1)
38	44-66-0880	Shoe Retainer	(1)
39	45-12-0999	Gearcase Insulator	(1)
40	45-16-0645	Shoe Assembly	(1)
41	45-22-0081	Sleeve	(1)
42	45-24-0719	Lock Off Lever	(1)
43	45-88-1555	Washer	(1)
44	40-50-8850	Disc Spring	(1)
45	42-12-0155	Wobble Shaft Axle	(1)
46	32-40-0719	Intermediate Gear	(1)
47	43-06-0685	Metal Plate	(1)
48	43-06-0676	Bronz Plate	(1)
49	43-78-0525	Drive Hub	(1)
50	36-92-0502	Wobble Shaft	(1)

FIG.	PART NO.	DESCRIPTION OF PART	NO. REQ.
★ 52	02-04-1510	Ball Bearing	(1)
★ 53	14-67-0135	Wobble Plate Assembly	(1)
54	34-60-1315	Retaining Ring	(1)
★ 55	06-82-7253	8-32 x 3/8" Pan Hd. Slit. Taptite T-20	(3)
56	44-86-0055	Bearing Retainer	(1)
57	45-36-1445	Spacer	(1)
58	06-55-3790	5/16-24 Spinlok Hex Nut	(1)
59	38-50-0680	Reciprocating Spindle	(1)
60	42-24-0610	Front Spindle Bearing	(1)
61	45-06-0501	Felt Seal	(1)
62	45-88-8577	Washer	(2)
63	42-52-0380	Bearing Cap	(1)
64	14-46-1011	Steel Quik-Lok Blade Clamp Kit	(1)
65	23-66-1719	Switch Assembly	(1)
66	22-18-1719	Carbon Brush Assembly - Black	(1)
67	22-18-0719	Carbon Brush Assembly - Red	(1)
68	23-94-0016	Leadwire Assembly - Black	(1)
69	23-94-0015	Leadwire Assembly - Red	(1)

★ = Part number change from previous service parts list.

**NOTES:**  
Press rear spindle bearing (33) flush to -.030 from front exterior face in diaphragm boss (21).

Torque spinlok hex nut (58) to 180 in./lbs. to 210 in./ lbs.

Needle bearing (3) is to be pressed from the open end flush to ±.005 to face of bearing boss of diaphragm (21).

Remove brush tubes (17) prior to removing armature assembly (15) from motor housing (27).

Install brush tubes (17) into motor housing (27) only after armature assembly (15) has been secured into motor housing (27).

MILWAUKEE ELECTRIC TOOL CORPORATION  
13135 W. LISBON RD., BROOKFIELD, WI 53005

Drwg. 1

FIGURE 25.12 The 3-D assembly drawing, service parts list, assembly notes, 3-D wiring diagram, and wiring specifications for the V28 Sawzall reciprocating saw. Courtesy Milwaukee Electric Tool Corporation

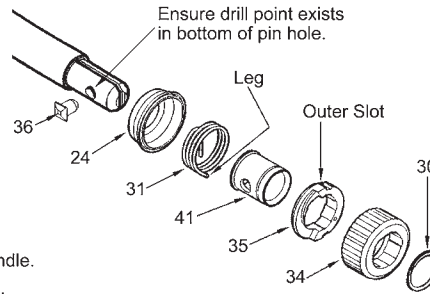


**REMOVING THE STEEL QUIK-LOK® BLADE CLAMP**

- Remove external retaining ring (30) and pull front cam (34) off.
- Pull lock pin (36) out and remove remainder of parts and discard.

**REASSEMBLY OF THE STEEL QUIK-LOK® BLADE CLAMP**

- Coat new lock pin with powdered graphite.
- Hold tool in a vertical position.
- Place spring cover (24) onto spindle.
- Slide torsion spring (31) onto spindle with spring leg on hole side of spindle.
- Slide sleeve (41) onto spindle aligning hole on sleeve with hole in spindle.
- Slide rear cam (35) over sleeve until it bottoms on sleeve shoulder, ensure spring leg inserts into hole in rear cam.
- Rotate rear cam in the direction of the arrows located on spring cover until there is clearance for lock pin (36) to be inserted into sleeve/spindle holes. Insert lock pin.
- Align front cam (34) inner ribs with rear cam outer slots and slide front cam onto sleeve until it bottoms.
- Retaining ring (30) groove should be completely visible.
- Attach retaining ring by separating coils and inserting end of ring into groove, then wind remainder of ring into groove. Ensure ring is seated in groove.
- Blade clamp should rotate freely. During normal usage, debris may not allow blade clamp to rotate freely. The use of spray lubricant can help free blade clamp. In extreme conditions, follow these instructions to remove, clean and reassemble blade clamp.



**WIRING INSTRUCTIONS**

Route carbon brush wires #1 and #2 into wire traps, as shown.

Carbon brush wires #1 and #2 are to be positioned with the wire crimps in the traps.

POSITION WIRES ON SWITCH TABS AND SOLDER, AS SHOWN.

SOLDER

.23 MAX.

**⚠ WARNING**  
**SWITCH POLARITY SENSITIVE**  
 If wired incorrectly, switch will be damaged and destroyed!

Place a heavy coat of Type "X" contact grease, No. 49-08-5000, in/on terminals of wires #3 and #4 after installing into connector block but prior to snapping on the connector block cover.

WIRING SPECIFICATIONS				
Wire No.	Wire Color	Origin or Gauge	Length	Terminals, Connectors and 1 or 2 End Wire Preparation
1	Red	22-18-0719	-----	Carbon brush assembly.
2	Black	22-18-1719	-----	Carbon brush assembly.
3	Red	23-94-0015	-----	Leadwire assembly.
4	Black	23-94-0016	-----	Leadwire assembly.

**BULK LEAD WIRE - BULLETIN NO. 58-01-0003**

TERMINAL DESCRIPTION		
Code	Part No.	Qty.

FIGURE 25.12 (Continued)

inspection process. Successful sample inspection is required before full-scale production can begin. Problems detected during the sample inspection have to be corrected, and, if necessary, more than one preproduction build might be required.

### Gate 3: Passing the Market Readiness Gate

---

After all elements of the execution phase are complete, many companies employ a final phase gate that assesses overall market readiness for the new product. At this phase gate, evidence is provided to verify the product is ready for shipment from all aspects of the company. Factors to be considered include:

- Ship testing.
- Field testing results.
- Verification that the packaging universal product code (UPC) scans correctly.
- All technical literature is available, such as service parts lists and operator manuals.
- Target inventory quantities are in stock.

After a successful final review, all groups sign off and the product goes into full production at this stage. The phase gate design process is completed and the product goes to distributors, suppliers, and stores for sale.

## AFTER FULL PRODUCTION

The product development process continues even beyond the time when the newly designed product goes into full production. In the modern manufacturing environment, companies are constantly evaluating the quality of their products and processes using continuous improvement methods. The following briefly describes the procedures that can be used to achieve these objectives for the new product previously discussed.

### Three Months After Full Production

---

Approximately three months after full production startup, a **postmortem review** is conducted. The postmortem review assesses the effectiveness of the product development process and the product development team. Representatives across departments are invited to the postmortem review meeting to provide a critique of the project's successes and failures. A grading system to determine effectiveness of the process during postmortem assessment addresses the following questions and issues:

- Were meetings timely and productive?
- Was the schedule met?
- Were there design changes after release?
- Were there things that had to be fixed on the product and in the process?
- How successful were sample inspection reports?
- Was supplier and vendor coordination and delivery successful?

- Were all quality inspection processes acceptable?
- Did the packaging system work, and were products delivered on time?
- Were agency approvals achieved without difficulty?
- How effective was the coordination between teams and departments?

### Twelve Months After Full Production

---

A **postproduction review** is conducted approximately 12 months after the start of production to assess the commercial success of the product. Issues to be considered include:

- Is the product achieving the desired volume?
- Is the product producing the desired income?
- Are field performance reports acceptable?
- Are the customers satisfied?
- Have there been service problems that need to be addressed?
- Are there any unresolved issues with production?
- Have there been warranty issues that need to be resolved?
- How good was the marketing research?

The Milwaukee Electric Tool Corporation's V28 Lithium-Ion Sawzall reciprocating saw and its related V28 products represent a success story for the manufacturing industry. Figure 25.13 shows a marketing piece used to promote the V28 reciprocating saw.

### Product End of Life

---

Companies continuously evaluate their products to be sure they maintain the preferred demand and sales required to have a desired profit. Just as with any income-producing business, product manufacturing and sales must constantly assess how well their products are selling and ask serious questions about the validity of keeping a product in production when sales decline. A process to discontinue a product is used when it is determined that the product is no longer needed, is at the end of the product life cycle, or the product has been replaced by a newer, improved model.

## CREATIVITY AND INNOVATION IN DESIGN

Creativity is very important in the world of engineering and design. Today's competitive market for products is placing a major need on the engineering design process to be more creative and innovative in order to meet the demands of faster, less-expensive, and better products. The only way to meet these demands is to do things differently, which is where creativity and innovation enter the picture. By definition, **creativity** is the ability to produce through imaginative skill, to make or bring into existence something new, and to form new associations and see patterns and relationships between diverse information. Creativity's partner is innovation. **Innovation** can be defined as the process of transforming a creative idea into a tangible product,

**Don't let the power go to your head.**

Introducing the revolutionary V28 Lithium-Ion line of cordless tools. The most powerful cordless tool system on the planet. Awesome power and up to twice the run time of an 18 volt with no extra battery weight. With a complete system of 6 new cordless tools to choose from, now you can work in ways you've never imagined. Just don't get too carried away. Experience the revolution yourself at [V28Power.com](http://V28Power.com) or see your local distributor. **Move to a higher power.**

**Milwaukee**

**V28**  
LITHIUM-ION  
[V28Power.com](http://V28Power.com)

INTRODUCING  
REVOLUTIONARY  
28 VOLT LITHIUM-ION  
TECHNOLOGY.

COMPARE THE  
DIFFERENCE

VOITS  
RUN TIME

18V NiCd  
V28 Li-Ion

CHOOSE FROM SIX  
POWERFUL TOOLS

BATTERY FUEL GAUGE

**FIGURE 25.13** A marketing piece used to promote the V28 Lithium-Ion Sawzall reciprocating saw. Courtesy Milwaukee Electric Tool Corporation

process, or service. Innovation is about improving the quality of a specific thing and allowing for more and better choices.

Using creativity techniques can lead to more effective problem-solving skills that facilitate productive and satisfying designs. Creativity may be required in the following situations:

- **New methods:** Problems in industry and construction often must be solved in areas that require original ideas or revisions of existing designs. *Creativity tools allow for new ideas to be generated.*
- **Determination:** A designer must have a lot of determination in order to keep working on the project until the problems are solved. *Creativity provides a way to look at problems from a different angle, making it easier to problem solve.*
- **Attitude:** The designer needs a positive attitude and must realize the possibilities of modern technology. *Creativity is all about possibilities.*

- **Confidence:** A good designer must have confidence in his or her ability to solve a problem within the marketing and manufacturing or construction requirements. *Creativity contributes to confidence by providing alternative solutions.*
- **Experimentation:** Careful testing and recording of data is a key to successful design. Experimentation, prototyping, testing, and analysis are used in the design process. *Creativity is the oil for experimentation and analysis.*
- **Logic:** A designer may lose ideas and waste valuable time without a logical approach to problem solving. A step-by-step design process works when followed and documented. *Creativity generates the ideas. The designer puts them in logical order.*

## Principles of Creativity

There are basic principles of creativity. These principles may not be natural, but with practice and determination, they can be

1. Look beyond the immediate object or situation—see the Big Picture.
2. Look for potential future consequences.
3. Always ask “Why” questions.
4. Always question and remain curious.
5. Keep an interest in a wide variety of areas—the broad base of knowledge helps make connections to new ideas.
6. Keep a daily journal of ideas, thoughts, and sketches.
7. Lateral thinking: Look at the idea from a number of different directions.
8. Mindmapping: Use free word association and brainstorming. Then organize the ideas into related areas.
9. Brainstorming: Use free association of ideas from a group to generate as many ideas as possible without passing judgment on any idea presented.

**FIGURE 25.14** Methods for developing creativity. Courtesy The Trane Co., La Crosse WI

cultivated and improved to increase creativity. People who are looked on as creative seem to have the ability to see the entire picture and make connections and combinations of seemingly unrelated subjects to produce new original ideas. The following are the basic creativity principles:

- *The ability to see relationships and patterns:* This means taking existing objects and combining them in different ways for new purposes.
- *The belief that you are creative:* The power of positive thinking.
- *The ability to look at a problem from a different point of view:* This involves changing the position or role in how a new idea or problem is approached.
- *Playfulness and humor:* Be a dreamer, brainstorm ideas, and surround yourself with inspiring ideas.
- *A work environment that is flexible, open, and autonomous:* In an ideal world, an unusual idea is never criticized or declared a failure. It may spark a creative solution.
- *Imagery and visualization:* Daydream, sketch, and visualize the future.
- *Subconscious thoughts:* Allow an idea to simmer awhile before making judgments. Ideas keep working in the subconscious mind even while you sleep.

In thinking of ways to become more creative in designs, remember the creative individual asks more *why* questions as opposed to *what* questions (see Figure 25.14).

These are just a few of the ways to foster the creative process. One way that works well for designers is to draw a sketch of the problem instead of using words. Many times a visual representation provides a fresh perspective and insights.

## Creativity Works Well in a Group

The world of engineering is moving to self-directed teams and concurrent team groups through which the real advantage for creative problem solving is realized. A group of people is able to bring diverse and varied perspectives to the problem or idea



**FIGURE 25.15** Teamwork in action. OJO Images/Getty Images

at hand. A group possesses accumulated knowledge and experience that one individual cannot even begin to exhibit. A team of people is in a position to learn from each other and consider various ideas and solutions, which creates a combined effort that leads to creativity (see Figure 25.15). The cross-functional team approach was discussed throughout this chapter.

## Creativity and Innovation

Creativity and innovation require a diverse and information- and interaction-rich environment. This is brought about with people who have different perspectives working together toward a common goal. This team of people requires accurate, up-to-date information and the proper tools.

Only in this kind of environment—where the organization is continuously learning about its products, services, processes, customers, technologies, industry competitors, and environment—can innovation thrive. Existing tools such as CAD, CAM, and CAE are good for routine problem solving but fall short in generating breakthrough concepts. To meet current market demand and customer requirements, creativity must lead to new and innovative ideas and processes.

In addition, remember that failure can be a learning experience and a necessary step in the design process. Sometimes design solutions fail. Failure prompts you to look at other solutions, and it promotes new ideas that lead to innovations. So when a design fails a test, think of it as an opportunity, not a dead end.

## CHANGE AND THE IMPACT ON THE DESIGN PROCESS

The designer naturally embraces change as part of the design process. Every design or idea goes through an evolution before its final outcome. Today the designer and the engineering team are attempting to reduce the amount of change in the design process by taking an integrated approach to the design process in the early stages of the design inception. By considering all aspects in the development of a product, the design team can

troubleshoot, in advance, any potential problems that would result in the change of a design. Solid modeling and rapid product development tools aid in early identification of design flaws and eliminate the need for change down the line.

Within the engineering profession, the ability to manage change is crucial to a project's success. Although there are many variations of the engineering change process, the structure and purpose are fairly standard. The objective of any engineering change process is to incorporate design changes as quickly and accurately as possible with a minimum of disruption and cost. Changes in the engineering design process serve many functions:

- They satisfy customer requests.
- They improve the product.
- They incorporate improvements in production and manufacturing.
- They resolve design problems.
- They integrate new technologies.

The engineering change process requires thoroughly documented entrance and exit criteria to ensure that design changes are accomplished accurately and in a timely manner as well as to ensure the maintenance of a complete history of the changes.

### Tracking Documents: ECO and ECR

As introduced in Chapter 15, *Working Drawings*, a tracking document is commonly referred to as an **engineering change order** (ECO) or an **engineering change request** (ECR). The style and procedure for an ECO or an ECR may differ between engineering firms, but the basic process is the same. Standard information is included on most document change forms (see Figure 25.16).

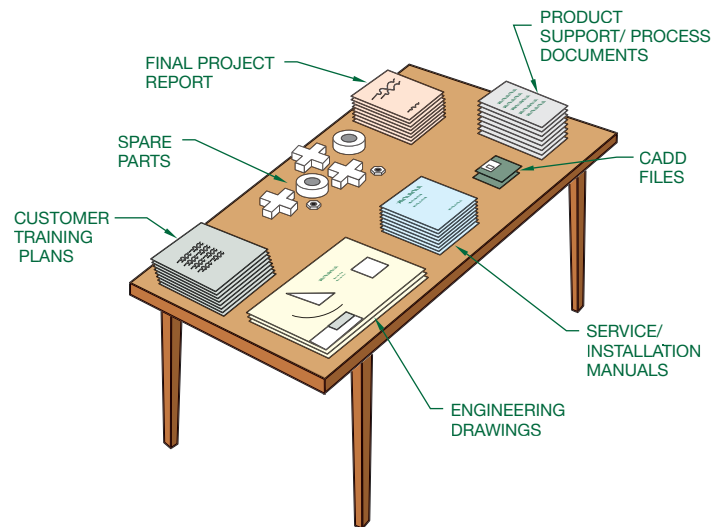
The engineering change process necessary to incorporate design change properly can be summarized in three steps:

1. Communicating the change.
2. Documenting the change.
3. Tracking the change.

In considering a potential change to a design, remember that change has an impact on the whole system within which the design is developed. A positive change for the designer can be a

- Engineering drawings
- Parts list or bill of materials
- Production specifications
- ECO/ECR document—problem description
- Engineering Change Order number
- Status of engineering change
- Effective date for change
- Approval list for reviewing changes

**FIGURE 25.16** Documents and information required for an ECO/ECR.  
© Cengage Learning 2012



**FIGURE 25.17** Items delivered to the customer. © Cengage Learning 2012

negative change for someone else who has a role in the design process. This is where a team meeting can be of value, because ideas can be considered by everyone involved.

## DESIGN DELIVERABLES

As a design process comes to an end, many different types of documents are created to document the product, process, installation procedures, and training plans. These materials are known in the industry as **deliverables**. Typical deliverables include such items as engineering and construction drawings or CADD files, prototypes, life cycle plans, installation manuals, and instruction guides. Deliverables can also include service and maintenance manuals, manufacturing process specifications, product support equipment, materials, spare parts, customer training plans, and final project reports (see Figure 25.17).

## THE DESIGN PROCESS RESPONDS TO CHANGES IN ENGINEERING

In examining all the changes in technology and the way in which engineering and product development occurs, the design process has responded to these changes with emerging engineering systems, such as the following:

- *Timing of the design:* Do it early in the design cycle. Doing it later costs more.
- *Reduce parts in a design:* This reduces costs throughout the whole assembly process.
- *Standardize parts:* This reduces cost by making parts interchangeable for different designs.
- *Keep the design simple:* The higher the tooling costs, the more complicated the design.
- *Use modular designs:* These reduce cost in design time because parts can be used in other designs. Modular designs also reduce assembly time.
- *Design with gravity in mind:* It is easier and more time efficient to assemble from the top down.

- *Eliminate fasteners:* This saves time and cost in assembly as well as maintenance.
- *Optimize part handling:* Costs go down and quality goes up with minimal proper assembly sequence.
- *Design for easy part mating:* Easier assembly through alignment for insertion speeds up assembly.
- *Provide nesting features in the design:* These help to show where features go.
- *Optimize manufacturing process sequence:* This increases the speed of getting the product to market.
- *Form follows function:* Design for the user.
- *Use design generations:* An initial design can be reused in the next generation of the product.



### Solid Enginyeria Ltd. Green Technology Application Engineering Design Process

For information on the Solid Enginyeria Ltd. Green Technology Application Engineering Design Process, go to the Student CD, select **Supplemental Material, Chapter 25**, and then **Solid Enginyeria Ltd. Green Technology Application Engineering Design Process**.

## GREEN TECHNOLOGY APPLICATION

The following discussion was created from information obtained from Solid Enginyeria Ltd. Paralleling the general design process information is the examination of a case study on a new product design from concept through production. The product used for this design sequence example is the Solid Enginyeria's PT-005 Roof Solar Tracker®. Solid Enginyeria Ltd. is dedicated to designing, prototyping, and testing positioning and power transmission mechanisms. Created in 1999 and based in Barcelona, Solid Enginyeria's main objective is to provide integral engineering services to a wide range of industries ([www.solid-enginyeria.com](http://www.solid-enginyeria.com)).

Currently, companies try to create environmentally friendly product designs, the main objective for many companies. Solid Enginyeria Ltd. developed a solar tracker for roofs as an answer for the green movement. With this product, the

company supports and promotes the use of photovoltaic panels and makes it possible to install the panels on roofs to free the ground from environmental impacts. Even roof installations continue to reduce environmental impact by creating an installation less than 1.5 meters high.

One main problem with adapting ground solar trackers to roofs is their weight. To solve this problem, Solid Enginyeria Ltd. developed an aluminum-structure optimizing weight. The entire structure is very portable and can be folded to transport anywhere. Each structure can even be carried by only two workers without much effort. Reducing weight produces less CO<sub>2</sub> in transportation and manufacturing. Also, 99% of the product's materials are fully recyclable, and the efficiency of standard solar panels increases more than 25% by tracking the sun to optimize the angle.

## PROFESSIONAL PERSPECTIVE

### ONLY THE FAST SURVIVE

The following is courtesy of Jim Leonard, Colorado Manufacturing Competitiveness, Denver, Colorado.

Every morning in Africa a gazelle wakes up, knowing it must outrun the fastest lion or it will be killed. At the same time a lion wakes up, knowing it must run faster than the slowest gazelle or it will starve. It does not matter whether you are a gazelle or a lion, when the sun comes up, you better be running. It is the law of the competitive jungle—only the fastest survive.

Source: A gazelle somewhere in Africa

Every product development team member has heard or read the law of the competitive jungle, and many have the law stamped on their foreheads. So why is rapid product development, also known as quick time to market, so important? There are many reasons, but the main reason is to satisfy customers' needs first and best.

*Design Tools for Engineering Teams: An Integrated Approach* describes many tools and practices that product developers use to improve product quality and reduce development time. But the toolbox of processes, practices, and technologies is constantly changing. What is state of the art today will generally be mainstream in two or three years.

State-of-the-art tools are rarely visible to anyone other than the most insightful industry observers, because best-in-class product developers keep their new tools and practices secret as long as possible. The following is a brief list of practices and technologies that best-in-class teams are using right now.

## CUSTOMER FOCUS

The 1990s were characterized by the increased role of **customer focus**, particularly in leading-edge manufacturers. That leading role has intensified in the 2000s, as articulated by Jacques Nasser, CEO of Ford: “[T]he real work at hand: getting inside the mind of the consumer to understand what he or she wants, aspires to become, and will be needed long after a purchase has been made.” Product development professionals are employing all kinds of innovative ways to understand customer needs, wants, and fantasies, including living with customers, having customers as permanent members of product development teams, and drilling down into and analyzing mountains of consumer data collected over the Internet.

## E-BUSINESS

Current applications of the Internet provide a distinct competitive advantage. Although Internet applications are appearing everywhere to improve customer service and reduce cycle times, most of the highest value-added applications are in product development. New and innovative applications continue to appear. Every one of the practices mentioned in this brief list applies Internet technologies in some way.

## COLLABORATIVE ENGINEERING

**Collaborative engineering** goes beyond concurrent engineering. It is the cooperative exchange of resources. For example, information, and ideas among a **virtual team** focused on an engineering-intensive project and having an overall common creative purpose. A virtual team is one whose members are not physically collocated but connected by distance communication technologies such as videoconferencing and e-mail.

## PREDICTIVE ENGINEERING, SIMULATION, AND VIRTUAL PROTOTYPES

With mainstream use of 3-D solid modeling, products can now be designed, built, tested to failure, and redesigned all in digital form. The designs can be nearly optimized before time, funds, and effort are spent on hardware. Entire

manufacturing plants can be simulated and optimized before the first cubic yard of concrete is poured to build the plant.

## VISUAL ENGINEERING

Three-dimensional solid modeling also allows all team members to see and understand information in the same way. Now the marketing, finance, and other nontechnical members can see product designs without needing the skill to read 2-D engineering drawings. Realistic images of engineered products can be shown more quickly and more affordably than building physical prototypes.

## SUPPLY CHAIN INTEGRATION AND VALUE CHAIN INTEGRATION

Companies and teams now coordinate the series of activities and processes that purchase, design, manufacture, and deliver products or services to customers. The **supply chain** or **value chain** is a system of organizations, people, technology, activities, information, and resources involved in moving a product or service from supplier to customer.

## DESIGN FOR EVERYTHING (DfX) HAS NEW MEANING

Design for everything (DfX) used to mean **design for manufacturability, assembly, test, service, and environment**. Now DfX is taking on several new functions.

- *Design for supply chain* optimizes use of the distinctive competencies of all supply chain members.
- *Design for postponement* allows for incorporation of distinctive and customizable features into a product until the latest possible production step.
- *Design for recycle, reuse, rebuild, and disposal*: Design for environment used to mean **consider ease of recycling**. In the future, expensive, high-information-content products will be designed for easy, inexpensive rebuilding or refurbishing, which eliminates the need for recycling or disposal for at least another life cycle. Less-expensive products will be designed for convenient, environmentally acceptable disposal, which may include recycling or components made of biodegradable material.

This list is not comprehensive. Enlightened product development professionals constantly scan the horizon for new practices, processes, and technologies and then intelligently apply them in their own projects. This is the only way to consistently satisfy customers’ needs first and best.

## WEB SITE RESEARCH

The following Web sites can provide you with information about the engineering design process.

Address	Company, Product, or Service
www.designnews.com	Trade magazine
www.partnerwerks.com	Information on design teams
www.sme.org	Society of Manufacturing Engineering
www.ame.org	Association for Manufacturing Excellence
www.manufacturingnews.com	Current articles
www.world.std.com	User interface engineering
www.milwaukeeetool.com	Milwaukee Electric Tool Corporation
www.wipo.int	World Intellectual Property Organization
www.dimensionprinting.com	3-D printing technology
www.globalspec.com	Technical products and services database
www.machinedesign.com	Design processes listings
www.avdel.textron.com	Fastener technical information
www.engineeringzone.com	Online handbooks
www.engr.usask.ca	FEA shareware
www.tenlinks.com	CAD sites
www.fmeainfocentre.com	FMEA worksheet
www.sv.vt.edu	Introduction to finite element analysis
www.engineeringforchange.org	ASME Engineering for Change (E4C)
www.solid-enginyeria.com	Solid Enginyeria Ltd.

## Chapter 25

### Chapter 25 The Engineering Design Process Test



To access the Chapter 25 test, go to the Student CD, select **Chapter Tests and Problems**, and then **Chapter 25**. Answer the questions

with short, complete statements, sketches, or drawings as needed. Confirm the preferred submittal process with your instructor.

### Chapter 25 The Engineering Design Process Problems

#### INSTRUCTIONS

##### Part 1: Problems 25.1 and 25.2

**PROBLEM 25.1** The following topics require research or industrial visitations. It is recommended that you research current professional magazines, check Web sites, visit local industries, or interview professionals in the engineering field. Your reports should emphasize the following:

- The link between manufacturing and engineering.
- Current technological advances.
- The design process.
- Team applications.

Select one or more of the following engineering fields or as assigned by your instructor and write a 250 word report for each.

- Mechanical engineering
- Structural engineering
- Civil engineering
- Electrical engineering
- Electronic engineering
- HVAC and sheet metal engineering
- Industrial pipe engineering



**PROBLEM 25.2** The following topics are changing the way engineering design is currently conducted. Engineering design and industry management models are systems used by the engineering world to address the constantly evolving engineering design process.

Research, observe, visit industry or product vendors, or search the Internet to find ways that the following items are allowing product development to be less expensive, faster, and of higher quality. Your presentation should emphasize the following:

- Process.
- Current technological advances.
- Team applications.
- Problem solving tools.
- Design applications for engineering.

Select one or more of the topics listed below or as assigned by your instructor and prepare an oral presentation for each.

Kaizen event  
 Just-in-time (JIT)  
 Toyota production system (TPS)  
 Lean manufacturing  
 Six Sigma  
 Concurrent engineering (CE)  
 Life cycle engineering  
 Integrated product development (IPD)  
 Knowledge-based engineering (KBE)  
 Total quality management (TQM)  
 Phase gate design process  
 Cross-functional team approach  
 Project portfolio management  
 A comparison between advanced research and existing product research  
 One or more of the phase gate design process stages  
 Industrial design  
 Quality function deployment  
 Design specification  
 Functioning prototypes  
 Intellectual properties  
 Patent research and invention disclosure  
 Failure mode effect analysis  
 Computational dynamics and finite element analysis  
 Design documentation  
 Preproduction build  
 Regulatory approval  
 After full production  
 The end of product

Creativity and innovation in design and principles of creativity

Change and the impact on the design process

Tracking documents

Design deliverables

## Design Problems

### Part 2: Problems 25.3 Through 25.24

The following problems involve using elements of the engineering design process identified in this chapter to design products from given concepts or for your own design projects. These design projects are best solved using a team approach, but they also can be done individually, depending on your course objectives and available participants. When using a team, identify a project leader and the responsibility of each team member, such as industrial designers, CADD designers and drafters, prototype makers, research specialists, marketing personnel, and specification developers. Some of the following steps may not be possible to accomplish because facilities, skills, or resources may not be available. Confirm this with your course objectives and instructor approval. Using the content of the engineering design process sections found in this chapter, include the following documents as part of the completion for each design.

**The Product Description and Business Case** This is a formal document, which specifies the features, pricing, and costs of a new product. This document communicates the customer needs to engineering and is the guidance on which engineering acts. Marketing gathers input from customers in the target market and also from departments such as purchasing, engineering, and sales.

**The Project Plan** This document is created by the project leader, who issues a schedule communicating the anticipated implementation time line for the project. The project team is also formed at this time. Each team member is given his or her assignment, and expectations are established. A major benefit of this practice is to ensure that all critical tasks are identified and accounted. List team members' names and identify their specific responsibilities and estimated deadlines.

**Industrial Design (ID) Team** Select team members who are possibly the most creative. These should be people who have the ability to be creative and work within engineering, manufacturing, and cost constraints. Create sketches illustrating various layouts, features, and styling. Usually 6 to 12 idea renderings are created in this concept design phase. Present the sketches to marketing and engineering for their input and assistance in narrowing down the concepts to one or two desired possibilities.

**Concept Refinement** In this step, the industrial designer begins concept refinement, where final renderings

and multiple views are created. This is also usually when mockups are created. The refined concept or concepts are then presented again to engineering and marketing. Once everyone is in agreement on a concept, one or more team members are selected to create CADD models.

**Customer Research** Customer input may involve classmates, friends, and family and can be established through one or more of the following means:

- Hard-copy distribution, phone surveys, or questionnaires.
- Telephone or field interviews with customers.
- Listening to and gathering customer recommendations.
- Using a Web site or other correspondence.

**Create the Design Specification** Establish technical specifications and performance targets. These are guidelines to the project team and help identify what constitutes a successful design. The design specification is a document with project requirements such as:

- Dimensions.
- Weight.
- Materials.
- General shape.
- Power requirements.
- Voltage requirements.
- Amperage specifications.
- Product life and durability requirements.
- Required agency approvals.
- Performance requirements.
- Included and optional accessories.
- General and special features.
- Environmental factors.

**The Development Phase** Construct a fully functioning prototype model. If facilities or skills are not available for the construction of a fully functioning prototype model, then build a model using other materials such as paper, cardboard, or foam.

**A Product Bill of Materials** Develop a product bill of materials to the best of your ability and knowledge. This document is used to establish the final product cost and to help organize the manufacturing process. Capital that must be spent to make parts in production, such as tooling, die, and pattern costs, also should be determined at this time.

**Design Documentation** Prepare a complete set of working drawings for the product. This includes an assembly drawing, parts list or bill of materials, detail drawings, and specifications. Establish a part or drawing numbering system. The assembly drawing can be in a 2-D or 3-D format as determined by your course objectives. Use the content in Chapter 15, *Working Drawings*, for reference.

**The Preproduction Build** If facilities and skills are available, manufacture and assemble at least one of the products. Do additional testing to determine how the first products off the production line meet the established design specifications.

**Marketing** Create a marketing plan along with at least one promotional flyer or brochure.

### PROBLEM 25.3 Trailer hitch design

Design a standard receiver trailer hitch for a pickup truck, light truck, or SUV with the following requirements:

- Quick change height adjustment.
- Quick change trailer ball to accommodate at least two ball sizes, such as 2 and 2.5 in. (50–60 mm).
- Corrosion-resistant material or finish.

### PROBLEM 25.4 Cheese cutter

Design a countertop cheese cutter with the following requirements:

- Compact design to accommodate a typical two-pound (1 kg) cheese block.
- Flat base to rest on any countertop or table.
- Adjustable cutting width.
- Corrosion-resistant material and finish.
- Easy to clean.
- Easy to store.

### PROBLEM 25.5 Electronics component door

Design a door covering the controls of an electronics component, such as a television, radio receiver, or DVD player with the following requirements:

- One touch opens.
- Opens slowly when door is released.

### PROBLEM 25.6 Ski cycle

Design a track drive system that can replace the rear wheel on a motorcycle, and design a ski to be used to replace the front wheel to allow a lightweight motorcycle to be used on snow.

### PROBLEM 25.7 ATV loader

Design hardware that can be mounted in a pickup truck bed that will allow one person to load and unload an ATV into the truck.

### PROBLEM 25.8 Paddle-powered boat

Design a paddle-powered boat with a rudder system.

### PROBLEM 25.9 Enclosed wheel lock

Design a lockable device to enclose the wheel of a boat trailer or utility trailer to keep the wheel from being stolen.

### PROBLEM 25.10 Manual can crusher

Design a manual can crusher with an ejection system. This is used to crush standard metal cans for recycling.

**PROBLEM 25.11 Electric-powered can crusher**

Redesign Problem 25.10 as an electric-powered can crusher with an ejection system.

**PROBLEM 25.12 Double-deck trailer**

Design a double-deck trailer that can be used to load two ATVs, one above the other.

**PROBLEM 25.13 Pop-up target system**

Design a pop-up target system that will automatically reset itself for target-shooting enthusiasts.

**PROBLEM 25.14 Appliance dolly**

Design an appliance dolly, powered or nonpowered, that will make it easier to use on stairs than a conventional dolly.

**PROBLEM 25.15 Skateboard trucks**

Design skateboard trucks to your own specifications in 150, 200, or 250 mm as desired. Incorporate the following features:

- Durability.
- Noncorrosive material.

**PROBLEM 25.16 Stock car roll cage**

Design a stock car roll cage that enhances driver protection, comfort, and ease of escape.

**PROBLEM 25.17 Bicycle helmet**

Design a bicycle helmet with the following general characteristics:

- Lightweight and impact-resistant material.
- Provide three variable size groups for children, adolescents, and adults.
- Aerodynamic.
- Shock resistance.

**PROBLEM 25.18 Bicycle seat**

Design a bicycle seat with the following general characteristics:

- Wide for maximum comfort.
- Fits any standard bicycle seat shaft.
- Absorbs shock for a smooth ride.

**PROBLEM 25.19 Golf club cart**

Design a golf club cart that carries a full set of golf clubs and has the following general features:

- Separates clubs for easy access and security.
- Places for extra balls, tees, scorecards, and other desired compartments.
- Large tires for stability and ease of movement.
- Folding leg to stand cart upright.
- Backpack style and hand-carrying features.

**PROBLEM 25.20 Collapsible music stand**

Design a mobile collapsible music stand that has the following general features:

- Folds into a maximum size of 8.5 × 11 in. (215 × 280 mm).
- Adjustable height from 11 in. (215 mm) to 48 in. (1200 mm).
- Sturdy, lightweight construction.

**PROBLEM 25.21 Mobile cappuccino store**

Design a mobile cappuccino store with the following general features:

- Mobile building with trailer hookup.
- Approximate dimensions 8 × 20 ft. (2400 × 6000 mm).
- Preparation facilities and storage.
- Service counter and window.
- Refrigeration unit.
- Coverings over wheels and tires, and trailer tongue.
- Modern or traditional exterior architectural style as desired.
- Signage.

**PROBLEM 25.22 Convenience store**

Design a convenience store with the following general features:

- Maximum 1,500 sq. ft. (140 m<sup>2</sup>).
- Cold cases.
- Freezer.
- Service counter.
- Restroom.
- Modern or traditional exterior architectural style as desired.

**PROBLEM 25.23 Office and warehouse combination facility**

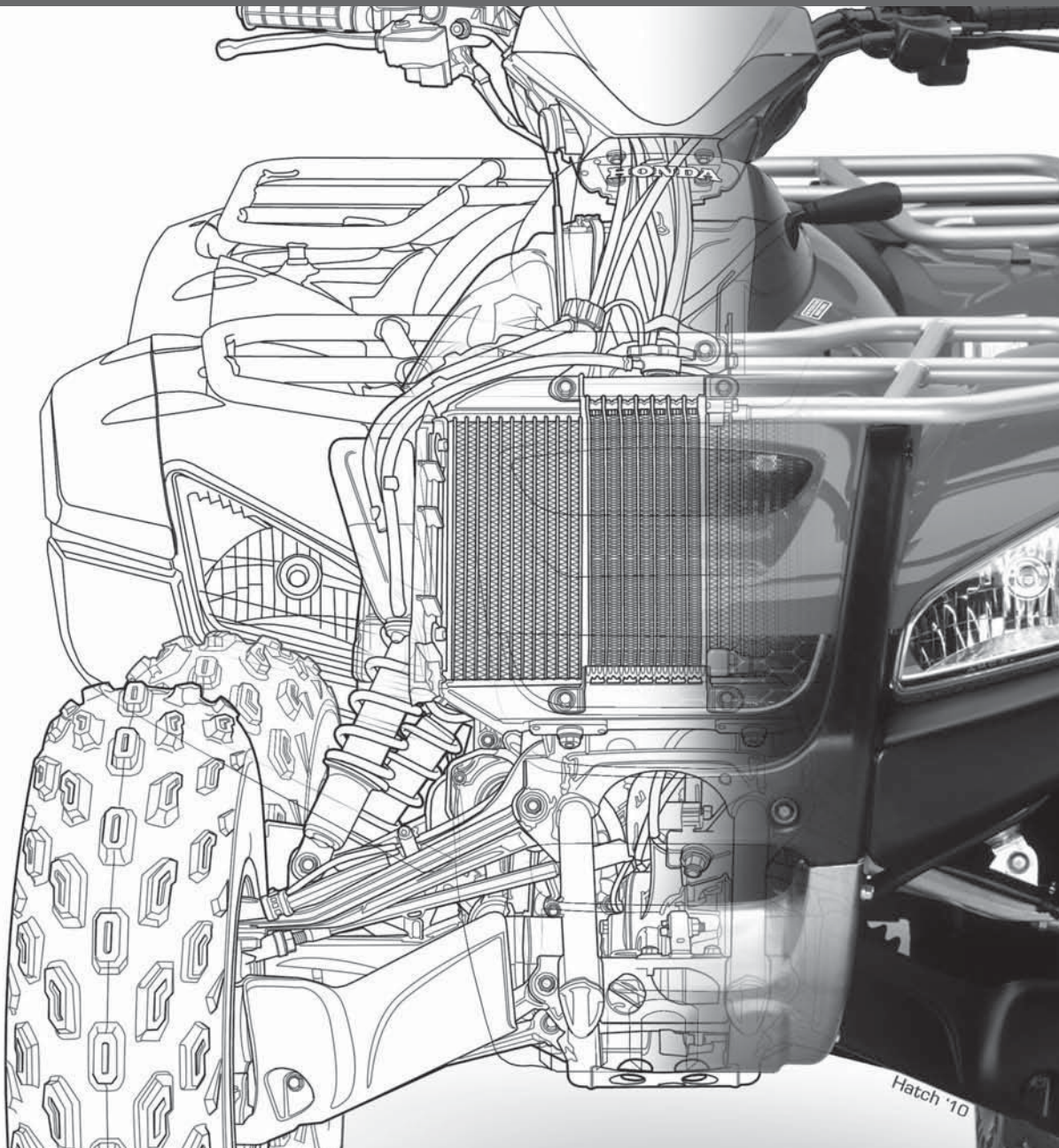
Design an office and warehouse combination facility for a small distribution company with the following general features:


- Office area maximum 1000 sq. ft. (90 m<sup>2</sup>) combined with a restroom and employee and guest lounge.
- Warehouse area maximum 2000 sq. ft. (180 m<sup>2</sup>).
- Loading dock with large door or doors.

**PROBLEM 25.24 Creative design**

Design a product of your own creation or from the ideas gathered from a team.

Engineering Drawing  
and Design Student CD



The Student CD available at the back of *Engineering Drawing and Design*, Fifth Edition, contains a variety of valuable features for you to use as you learn engineering drawing and design. The CD icon, , which is placed throughout this textbook,

directs you to features found on the CD.

## INSTRUCTIONS

Access the CD to view the contents, including Appendices, ASME Print Reading or Drawing Exercises, Chapter Tests and Chapter Drafting Problems, Chapter Math Problems, Drafting Templates, Reference Material, and Supplemental Material.

- Place the CD in your CD drive.
- The CD should open (start) automatically.
- If the CD does not start automatically, pick the Start button in the lower-left corner of your screen, and select Run, followed by accessing the CD drive on your computer.
- Choose the desired option from the main MENU.

## CD CONTENTS

### ASME Print Reading or Drawing Exercises

These are actual industry drawing files that contain *intentional ASME errors*. You can correct the drawing files using CADD or redline prints to conform to accepted ASME standards. This provides a valuable supplement for learning ASME standards. Searching actual industry drawings to find errors helps you form a keen eye for correct drafting presentation and compliance with national standards. This activity is the function of a **drafting checker** in industry. A drafting checker takes a completed drawing from a drafter and evaluates the drawing for proper standards, technical details, and accuracy for product design and dimensioning applications. After checking, the drawing goes back to the drafter for final completion before going to the design engineer for approval and on to manufacturing. The checker often uses red lines to mark drawing errors and required edits on a print or on the CADD file. The drafter then systematically checks off each item as corrections are made to ensure that every item is correctly edited. Possessing this skill allows you to become more familiar with proper ASME standards, correct drawing layouts, and proper dimension placement when creating your own drawings and when correcting drawings created by others.

## Reference Material

### Descriptive Geometry I

Descriptive geometry is a drafting method used to study 3-D geometry with 2-D drafting applications where planes of projections analyze and describe the true geometric

characteristics. Descriptive geometry principles are valuable for determining true shapes of planes; angles between two lines, two planes, or a line and a plane; and for locating the intersection between two planes, a cone and a plane, or two cylinders. Problems are solved *graphically* by projecting points onto selected adjacent projection planes in an imaginary projection system.

### Descriptive Geometry II

This reference material continues from Descriptive Geometry I, allowing you to solve many engineering problems where the direction of lines and planes must be determined. The direction of lines and planes is identified in space by a variety of ways, depending on their uses.

### Engineering Charts and Graphs

This reference material provides you with the most comprehensive and detailed coverage available on the design and drafting of engineering charts and graphs.

### Engineering Drawing and Design Math Applications

This reference material provides you with comprehensive math instruction for engineering design and drafting and related fields. The content parallels the math applications and problems in chapters throughout this textbook. This supplemental material is presented with numerous examples in a manner that is easy to use and understand.

### Fluid Power

This reference material provides you with complete coverage of fluid power drafting and design applications, including hydraulic, fluid power, and pneumatic terminology, rules, symbols, systems, and diagrams.

## Supplemental Materials

### Chapter 1 Introduction to Engineering Drawing and Design

- ADDA Professional Certification Competencies
- ADDA Student Chapter Information
- ASME Drafting Standards List
- CADD Skill Standards
- United States National CAD Standard

### Chapter 2 Drafting Equipment, Media, and Reproduction Methods

- Digitizing and Scanning Existing Drawings
- Dimensions of Sheet Items
- Drafting Furniture
- Drafting Machine Controls and Operation
- Erasers and Erasing

Making a Diazo Print  
 Other Pencils and Pencil Techniques  
 Taping Down a Drawing  
 Technical Pens, Pen Cleaning, and Ink  
 Using a Compass  
 Using Irregular Curves  
 Using Polyester Film  
 Using Templates

### Chapter 3 Computer-Aided Design and Drafting (CADD)

Automotive Animation  
 BMX Engine Animation  
 CADD Hardware  
 CADD Skill Standards  
 Chute Billie Animation  
 Medical Animation  
 Solid Model Assembly Process Animation  
 Solid Model Stress Analysis Animation  
 United States National CAD Standard

### Chapter 4 Manufacturing Materials and Processes

Green Technology Application  
 Plastic Resin Identification Codes

### Chapter 6 Lines and Lettering

Manual Lines and Lettering

### Chapter 7 Drafting Geometry

Common Manual Geometric Constructions

### Chapter 14 Pictorial Drawings and Technical Illustrations

3-D Animation of Electric Motor

### Chapter 16 Mechanisms: Linkages, Cams, Gears, and Bearings

Animation of a Cam Operation  
 Animation of Backhoe Linkage Mechanism

### Chapter 21 Industrial Process Pipe Drafting

ASTM International: Standards for Steel Pipes, Tubes, and Fittings

### Chapter 23 Heating, Ventilating, and Air-Conditioning (HVAC), and Pattern Development

3-D HVAC Models  
 Effect of Duct Shape on Duct Sizing

### Chapter 25 The Engineering Design Process

Solid Ingneria Ltd. Green Technology Application  
 Engineering Design Process

## Supplemental Appendices

---

Appendix A American National Standards of Interest to Designers, Architects, and Drafters  
 Appendix B ASME Standard Line Types  
 Appendix C Dimensioning and Tolerancing Symbols  
 Appendix D Designation of Welding and Allied Processes by Letters  
 Appendix E Symbols for Pipe Fittings and Valves  
 Appendix F Computer Terminology and Hardware

## Supplemental Chapter Tests and Problems

---

### Chapter 1 Introduction to Engineering Drawing and Design

Test

### Chapter 2 Drafting Equipment, Media, and Reproduction Methods

Test

### Chapter 3 Computer-Aided Design and Drafting (CADD)

Test

### Chapter 4 Manufacturing Materials and Processes

Test

### Chapter 5 Sketching Applications

Test  
 Problems

### Chapter 6 Lines and Lettering

Test  
 Problems

### Chapter 7 Drafting Geometry

Test  
 Problems

### Chapter 8 Multiviews

Test  
 Problems

### Chapter 9 Auxiliary Views

Test  
 Problems

### Chapter 10 Dimensioning and Tolerancing

Test  
 Problems

**Chapter 11** Fasteners and Springs

Test  
Problems

**Chapter 12** Sections, Revolutions, and  
Conventional Breaks

Test  
Problems

**Chapter 13** Geometric Dimensioning and  
Tolerancing

Test  
Problems

**Chapter 14** Pictorial Drawings and Technical  
Illustrations

Test  
Problems

**Chapter 15** Working Drawings

Test  
Problems

**Chapter 16** Mechanisms: Linkages, Cams, Gears,  
and Bearings

Test  
Problems

**Chapter 17** Belt and Chain Drives

Test  
Problems

**Chapter 18** Welding Processes and  
Representations

Test  
Problems

**Chapter 19** Precision Sheet Metal Drafting

Test  
Problems

**Chapter 20** Electrical and Electronics Drafting

Test  
Problems

**Chapter 21** Industrial Process Pipe Drafting

Test  
Problems

**Chapter 22** Structural Drafting

Test  
Problems

**Chapter 23** Heating, Ventilating, and  
Air-Conditioning (HVAC), and Pattern  
Development

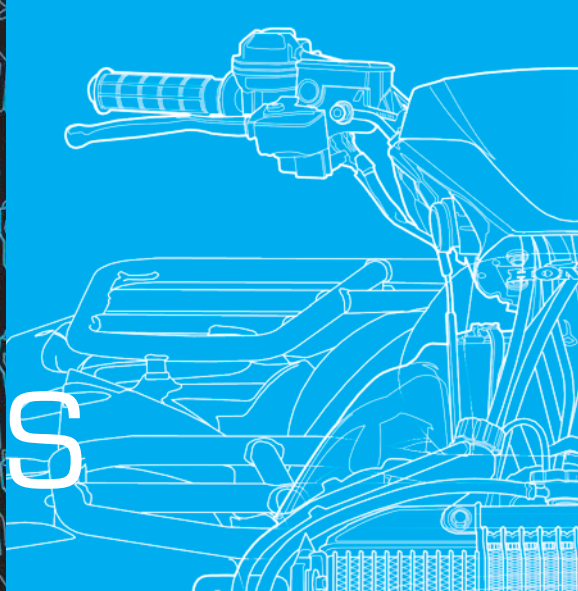
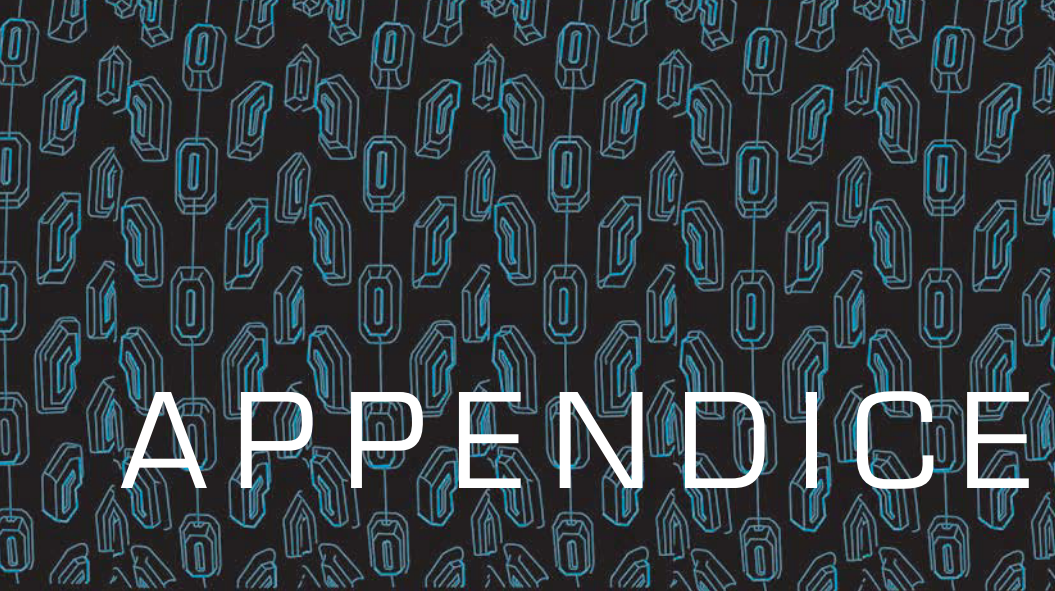
Test  
Problems

**Chapter 24** Civil Drafting

Test  
Problems

**Chapter 25** The Engineering Design Process

Test



# APPENDICES

<b>APPENDIX A</b>	<b>Abbreviations</b> . . . . .	1163
<b>APPENDIX B</b>	<b>Conversion Charts</b> . . . . .	1166
Table 1	Inches to Millimeters . . . . .	1166
Table 2	Millimeters to Inches . . . . .	1166
Table 3	Inch/Metric Equivalents . . . . .	1166
Table 4	Inch/Metric Conversion—Length, Area, Capacity, Weight . . . . .	1167
<b>APPENDIX C</b>	<b>Mathematical Rules Related to the Circle</b> . . . . .	1168
<b>APPENDIX D</b>	<b>General Applications of SAE Steels</b> . . . . .	1169
<b>APPENDIX E</b>	<b>Surface Roughness Produced by Common Production Methods</b> . . . . .	1170
<b>APPENDIX F</b>	<b>Wire Gages (Inches)</b> . . . . .	1171
<b>APPENDIX G</b>	<b>Sheet Metal Gages (Inches)</b> . . . . .	1172
<b>APPENDIX H</b>	<b>Sheet Metal Thicknesses (Millimeters)</b> . . . . .	1173
<b>APPENDIX I</b>	<b>Standard Allowances, Tolerances, and Fits</b> . . . . .	1174
Table 5	Allowances and Tolerances Preferred Hole Basis Fits . . . . .	1174
	Allowances and Tolerances Preferred Shaft Basis Fits . . . . .	1174
	Allowances and Tolerances Description of Preferred Fits . . . . .	1175
Table 6	American National Standard Fits—Running and Sliding Fits . . . . .	1176
	American National Standard Fits—Clearance Locational Fits . . . . .	1178
	American National Standard Fits—Transition Locational Fits . . . . .	1180
	American National Standard Fits—Interference Locational Fits . . . . .	1181
	American National Standard Fits—Force and Shrink Fits . . . . .	1182
Table 7	Metric Limits and Fits—Preferred Hole Basis Clearance Fits . . . . .	1184
	Metric Limits and Fits—Preferred Shaft Basis Clearance Fits . . . . .	1186
Table 8	Metric Tolerance Zones for Internal (Hole) Dimensions . . . . .	1188
	Metric Tolerance Zones for External (Shaft) Dimensions . . . . .	1189
<b>APPENDIX J</b>	<b>Unified Screw Thread Variations</b> . . . . .	1190
Table 9	Unified Standard Screw Thread Series . . . . .	1191
<b>APPENDIX K</b>	<b>Metric Screw Thread Variations</b> . . . . .	1192
<b>APPENDIX L</b>	<b>ASTM and SAE Grade Markings for Steel Bolts and Screws</b> . . . . .	1193
<b>APPENDIX M</b>	<b>Cap Screw Specifications</b> . . . . .	1194
Table 10	Dimensions of Hex Cap Screws (Finished Hex Bolts) . . . . .	1194
Table 11	Dimensions of Hexagon and Spline Socket Head Cap Screws (1960 Series) . . . . .	1195
Table 12	Dimensions of Hexagon and Spline Socket Flat Countersunk Head Cap Screws . . . . .	1196
Table 13	Dimensions of Slotted Flat Countersunk Head Cap Screws . . . . .	1197
Table 14	Dimensions of Slotted Round Head Cap Screws . . . . .	1198
Table 15	Dimensions of Slotted Fillister Head Cap Screws . . . . .	1198
<b>APPENDIX N</b>	<b>Machine Screw Specifications</b> . . . . .	1199
Table 16	Dimensions of Slotted Flat Countersunk Head Machine Screws . . . . .	1199
<b>APPENDIX O</b>	<b>Set Screw Specifications</b> . . . . .	1200
Table 17	Dimensions of Hexagon and Spline Socket Set Screws . . . . .	1200




<b>APPENDIX P</b>	<b>Hex Nut Specifications</b> . . . . .	1202
Table 18	Dimensions of Hex Nuts and Hex Jam Nuts . . . . .	1202
<b>APPENDIX Q</b>	<b>Key and Keyseat Specifications</b> . . . . .	1203
Table 19	Woodruff Key Dimensions . . . . .	1203
Table 20	Woodruff Keyseat Dimensions . . . . .	1205
Table 21	Key Size Versus Shaft Diameter . . . . .	1207
Table 22	Key Dimensions and Tolerances . . . . .	1208
Table 23	Gib Head Nominal Dimensions . . . . .	1208
Table 24	Class 2 Fit for Parallel and Taper Keys . . . . .	1209
<b>APPENDIX R</b>	<b>Tap Drill Sizes</b> . . . . .	1210
Table 25	Decimal Equivalents and Tap Drill Sizes (Letter and Number Drill Sizes) . . . . .	1210
<b>APPENDIX S</b>	<b>Concrete Reinforcing Bar (Rebar) Specifications</b> . . . . .	1211
<b>APPENDIX T</b>	<b>Common Welded Wire Reinforcement Specifications</b> . . . . .	1212
Table 26	Wire Size Comparison . . . . .	1212
Table 27	Common Styles of Metric Welded Wire Reinforcement (WWR) . . . . .	1214
<b>APPENDIX U</b>	<b>ASTM A500 Square and Rectangular Structural Tubing Specifications</b> . . . . .	1215
<b>APPENDIX V</b>	<b>Structural Metal Shape Designations</b> . . . . .	1216
Table 28	W, M, S, and HP Shapes—Dimensions . . . . .	1216
Table 29	Channels American Standard and Miscellaneous—Dimensions . . . . .	1221
	Channels Miscellaneous—Dimensions . . . . .	1222
<b>APPENDIX W</b>	<b>Corrosion-Resistant Pipe Fittings</b> . . . . .	1223
Table 30	Welding Fittings and Forged Flanges—Dimensions . . . . .	1223
Table 31	Threaded Fittings and Threaded Couplings, Reducers, and Caps . . . . .	1225
<b>APPENDIX X</b>	<b>Valve Specifications</b> . . . . .	1226
Table 32	Wrought Steel Pipe and Taper Pipe Threads—American National Standard . . . . .	1229
Table 33	Cast Iron Pipe Screwed Fittings, 125 lb.—American National Standard . . . . .	1230
<b>APPENDIX Y</b>	<b>PVC Pipe Dimensions in Inches</b> . . . . .	1231
<b>APPENDIX Z</b>	<b>Rectangular and Round HVAC Duct Sizes</b> . . . . .	1233
<b>APPENDIX AA</b>	<b>Spur and Helical Gear Data</b> . . . . .	1234
<b>APPENDIX BB</b>	<b>CADD Drawing Sheet Sizes, Settings, and Scale Factors</b> . . . . .	1235

## SUPPLEMENTAL APPENDICES

Access the CD accompanying *Engineering Drawing and Design, 5e* for the following appendices:

- CD APPENDIX A** American National Standards of Interest to Designers, Architects, and Drafters
- CD APPENDIX B** ASME Standard Line Types
- CD APPENDIX C** Dimensioning and Tolerancing Symbols and ASME Dimensioning Rules
- CD APPENDIX D** Designation of Welding and Allied Processes by Letters
- CD APPENDIX E** Symbols for Pipe Fittings and Valves
- CD APPENDIX F** Computer Terminology and Hardware

 There is a CD available at the back of *Engineering Drawing and Design, 5e*. The CD contains a variety of valuable features for you to use as you learn engineering drawing and design. The CD icon, placed throughout this textbook, directs you to features found on the CD.

## CD INSTRUCTIONS

Access the CD to view the CD materials, appendices, chapter tests, and selected chapter problems:

- Place the CD in your CD drive.
- The CD should open (start) automatically.
- If the CD does not start automatically, pick the Start button in the lower left corner of your screen, and select Run, followed by accessing the CD drive on your computer.
- Pick the desired content from the button selections on the left side of the CD window.

## APPENDIX A ABBREVIATIONS

The following are standard abbreviations commonly used on working drawings:

Above finished floor . . . . .	AFF	Cadmium . . . . .	CAD	Degree . . . . .	(°) or DEG
Accessory . . . . .	ACCESS	Capacity . . . . .	CAP	Department . . . . .	DEPT
Accumulate . . . . .	ACCUM	Carbon steel . . . . .	CS	Detail . . . . .	DET
Adaption . . . . .	ADAPT	Cast iron . . . . .	CI	Develop . . . . .	DEV
Addendum . . . . .	ADD	Cast steel . . . . .	CS	Deviation . . . . .	DEV
Addition . . . . .	ADD	Casting . . . . .	CST	Dew point . . . . .	DP
Airfoil . . . . .	AF	Ceiling or cooling . . . . .	CLG	Diagonal . . . . .	DIAG
Air pressure drop . . . . .	APD	Center . . . . .	CTR	Diameter . . . . .	DIA, Ø
Alteration . . . . .	ALT	Center of gravity . . . . .	CG	Diametral pitch . . . . .	DP
Alternate . . . . .	ALT	Centerline . . . . .	(C) or CL	Dimension . . . . .	DIM
Alternating current . . . . .	AC	Centigrade . . . . .	C	Direct current . . . . .	DC
Alternative . . . . .	ALT	Centimeter . . . . .	CM	Direct digital control . . . . .	DDC
Altitude . . . . .	ALT	Chamfer . . . . .	CHAM	Distance . . . . .	DIST
Aluminum . . . . .	AL	Change . . . . .	CHG	Division . . . . .	DIV
American Design		Check . . . . .	CHK	Double width double inlet . . . . .	DWDI
Drafting Association . . . . .	ADDA	Chief . . . . .	CH	Down . . . . .	DN
American Iron and		Chromium . . . . .	CHR	Drawing . . . . .	DWG
Steel Institute . . . . .	AISI	Circular pitch . . . . .	CP	Each . . . . .	EA
American Society for		Circumference . . . . .	CIRC	Eccentric . . . . .	ECC
Testing Materials . . . . .	ASTM	Clockwise . . . . .	CW	Effective . . . . .	EFF
American Society of		Cold drawn steel . . . . .	CDS	Efficiency . . . . .	EFF
Mechanical Engineers . . . . .	ASME	Cold rolled steel . . . . .	CRS	Electric, Electrical . . . . .	ELEC
American Wire Gage . . . . .	AWG	Company . . . . .	CO	Elevation . . . . .	ELEV
Ampere . . . . .	AMP	Composition . . . . .	COMP	Engineer . . . . .	ENGR
Apparatus housing plenum . . . . .	AHP	Compression, Compressor . . . . .	COMP	Engineering . . . . .	ENGRG
Approved . . . . .	APPD	Concentric . . . . .	CONC	Entering air temperature . . . . .	EAT
Approximate, Approximately . . . . .	APPROX	Concrete . . . . .	CONC	Entering dry bulb . . . . .	EDB
Architect, Architectural . . . . .	ARCH	Condition . . . . .	COND	Entering fluid temperature . . . . .	EFT
Assembly . . . . .	ASM	Conductor . . . . .	COND	Entering water temperature . . . . .	EWT
Attach . . . . .	ATT	Conduit . . . . .	CDT	Entering wet bulb . . . . .	EWB
Authorize . . . . .	AUTH	Connect, Connection,		Equal . . . . .	EQ
Automatic . . . . .	AUTO	Connector . . . . .	CONN	Equipment . . . . .	EQUIP
Auxiliary . . . . .	AUX	Continue, Continued,		Equivalent . . . . .	EQUIV
Average . . . . .	AVG	Continuation . . . . .	CONT	Estimate . . . . .	EST
Backdraft damper . . . . .	BDD	Control . . . . .	CONT	Etcetera . . . . .	ETC
Backward inclined . . . . .	BI	Copper . . . . .	CU	Exhaust . . . . .	EXH
Balance . . . . .	BAL	Copyright . . . . .	copr., ©, or ®	Exhaust air . . . . .	EA
Basement . . . . .	BSMT	Corporation . . . . .	CORP	Exhaust air damper . . . . .	EAD
Battery . . . . .	BAT	Correspond . . . . .	CORRES	Existing . . . . .	EXIST
Bearing . . . . .	BRG	Corrosion resistant steel . . . . .	CRES	Expansion . . . . .	EXP
Bill of materials . . . . .	B/M	Counterbalance . . . . .	CBAL	Extension . . . . .	EXT
Bracket . . . . .	BRKT	Counterbore . . . . .	CBORE	External . . . . .	EXT
Brass . . . . .	BRS	Counterclockwise . . . . .	CCW	External static pressure . . . . .	ESP
British thermal unit . . . . .	BTU	Counterdrill . . . . .	CDRILL	Extractor . . . . .	EX
British thermal units		Countersink . . . . .	CSK	Extrusion . . . . .	EXTR
per hour . . . . .	BTUH	Counterweight . . . . .	CTWT	Face velocity . . . . .	FV
Bronze . . . . .	BRZ	Cubic . . . . .	CU	Fahrenheit . . . . .	F
Brown and Sharpe . . . . .	B&S	Cubic centimeter . . . . .	CC	Feet, Foot . . . . .	FT
Building . . . . .	BLDG	Cubic feet per hour . . . . .	CFH	Feet per minute . . . . .	FPM
Bushing . . . . .	BUSH	Cubic feet per minute . . . . .	CFM	Feet per second . . . . .	FPS
		Cubic feet per second . . . . .	CFS	Figure . . . . .	FIG
		Cubic foot . . . . .	CU FT	Fillister head . . . . .	FIL HD
		Cubic inch . . . . .	CU IN	Filter . . . . .	FILT
		Cycle . . . . .	CY	Finish . . . . .	FIN
		Dedendum . . . . .	DED	Fitting . . . . .	FTG
		Deflection . . . . .	DEFL	Fixture unit . . . . .	FU

Flat . . . . .	FL	Kilowatt hour . . . . .	KWH	Of true position . . . . .	OTP
Flat head . . . . .	FHD	Knock out . . . . .	KO	On Center, On center distance . . . . .	OC
Flexible . . . . .	FLEX	Laboratory . . . . .	LAB	Operate . . . . .	OPER
Fluid pressure drop . . . . .	FPD	Leaving . . . . .	LVG	Opposite . . . . .	OPP
Foot . . . . .	( <sup>!</sup> ) or FT	Leaving air temp. . . . .	LAT	Optional . . . . .	OPT
Foot pounds . . . . .	FT LB	Leaving dry bulb . . . . .	LDB	Original . . . . .	ORIG
Forging . . . . .	FORG	Leaving fluid temperature . . . . .	LFT	Ounce . . . . .	OZ
Forward . . . . .	FWD	Leaving water temperature . . . . .	LWT	Outside air . . . . .	OSA
Forward curved . . . . .	FC	Leaving wet bulb . . . . .	LWB	Outside air damper . . . . .	OAD
Front . . . . .	FRT	Left hand . . . . .	LH	Outside diameter . . . . .	OD
Future . . . . .	FUT	Length . . . . .	L or LG	Outside radius . . . . .	OR
Gage (Gauge) . . . . .	GA	Linear feet . . . . .	LF	Oval head . . . . .	OV HD
Gallon . . . . .	GAL	Lock washer . . . . .	LWASH	Overall . . . . .	OA
Gallons per hour . . . . .	GPH	Longitude, Longitudinal . . . . .	LONG	Oxygen . . . . .	OXY
Gallons per minute . . . . .	GPM	Lower . . . . .	LWR	Package, Packing . . . . .	PKG
Galvanize, Galvanized . . . . .	GALV	Lubricate . . . . .	LUB	Page . . . . .	P
Gasket . . . . .	GSKT	Machine . . . . .	MACH	Part . . . . .	PT
Generator . . . . .	GEN	Magnesium . . . . .	MG	Parting line . . . . .	PL
Glycol . . . . .	GLY	Maintenance . . . . .	MAINT	Patent . . . . .	PAT
Grain . . . . .	GRN	Malleable . . . . .	MAL	Pattern . . . . .	PATT
Gravity . . . . .	G	Manufacture, Manufacturer . . . . .	MFR	Perpendicular . . . . .	PERP
Grind . . . . .	GRD	Material . . . . .	MATL	Phase . . . . .	PH
Harden . . . . .	HDN	Maximum . . . . .	MAX	Pint . . . . .	PT
Hardware . . . . .	HDW	Maximum material condition . . . . .	MMC	Pitch . . . . .	P
Head . . . . .	HD	Mechanical . . . . .	MECH	Pitch circle . . . . .	PC
Heating . . . . .	HTG	Medium . . . . .	MED	Pitch diameter . . . . .	PD
Heat treat . . . . .	HT TR	Memorandum . . . . .	MEMO	Plan view . . . . .	PV
Height . . . . .	H or HGT	Mercury . . . . .	HG	Point on line . . . . .	POL
Hexagon . . . . .	HEX	Mile . . . . .	MI	Polypropylene . . . . .	PP
Horizontal . . . . .	HORIZ	Miles per hour . . . . .	MPH	Polyvinyl chloride . . . . .	PVC
Horsepower . . . . .	HP	Millimeter . . . . .	MM	Position . . . . .	POSN
Hot rolled steel . . . . .	HRS	Minimum . . . . .	MIN	Positive . . . . .	(+) or POS
Hour . . . . .	HR	Minute . . . . .	( <sup>!</sup> ) or MIN	Pound . . . . .	LB
Hydraulic . . . . .	HYD	Miscellaneous . . . . .	MISC	Pounds per square inch . . . . .	PSI
Illustration . . . . .	ILLUS	Modify . . . . .	MOD	Preliminary . . . . .	PRELIM
Inch, Inches . . . . .	( <sup>!</sup> ) or IN.	Molding . . . . .	MLDG	Pressure . . . . .	PRESS
Inch ounce . . . . .	IN. OZ	Mounted . . . . .	MTD	Process . . . . .	PROC
Inch pounds . . . . .	IN. LB	Mounting . . . . .	MTG	Product, Production . . . . .	PROD
Inclusive . . . . .	INCL	National . . . . .	NATL	PVC coated steel . . . . .	PVS
Information . . . . .	INFO	National Electrical Mfg. Association . . . . .	NEMA	Quality . . . . .	QUAL
Inside diameter, Inside dimension . . . . .	ID	National Machine Tool Builders Association . . . . .	NMTBA	Quantity . . . . .	QTY
Inside radius . . . . .	IR	Negative . . . . .	(-) or NEG	Quart . . . . .	QT
Inspection . . . . .	INSP	Nickel . . . . .	NI	Quarter . . . . .	QTR
Installation . . . . .	INSTL	No drawing . . . . .	ND	Radius . . . . .	R (RAD)
Instrument . . . . .	INST	Nominal . . . . .	NOM	Rear view . . . . .	RV
Insulation . . . . .	INSL or INSUL	Nonstandard . . . . .	NONSTD	Rectangular . . . . .	RECT
Interchangeable . . . . .	INTCHG	Normally closed . . . . .	NC	Reduction . . . . .	RED
Intermediate . . . . .	INTER	Normally open . . . . .	NO	Reference . . . . .	REF
Internal . . . . .	INT	Not in contract . . . . .	NIC	Regardless of feature size . . . . .	RFS
Invert elevation . . . . .	IE	Obsolete . . . . .	OBS	Regular . . . . .	REG
Isolator, Isolation . . . . .	ISOL			Reinforce . . . . .	REINF
Joint . . . . .	JT			Relative humidity . . . . .	RH
Kilometer . . . . .	KM			Remove . . . . .	REM
Kilowatt . . . . .	KW			Require . . . . .	REQ

Required . . . . .	REQD	Single wall plenum . . . . .	SWP	Tracer . . . . .	TCR
Resistor . . . . .	RES	Single width single inlet . . . . .	SWSI	Trademark . . . . .	TM
Return air . . . . .	RA	Sketch . . . . .	SK	Transformer . . . . .	TRANS
Return air damper . . . . .	RAD	Smoke damper . . . . .	SD	Transmission . . . . .	TRANS
Reverse . . . . .	REV	Society of Automotive Engineers . . . . .	SAE	Transverse . . . . .	TRANSV
Revision . . . . .	REV	Special . . . . .	SPL	True length . . . . .	TL
Revolution . . . . .	REV	Specification . . . . .	SPEC	True position . . . . .	TP
Revolutions per minute . . . . .	RPM	Specific gravity . . . . .	SP GR	True view . . . . .	TV
Right hand . . . . .	RH	Spherical . . . . .	SPHER	Turnbuckle . . . . .	TRNBKL
Root diameter . . . . .	RD	Spot face . . . . .	SF	Typical . . . . .	TYP
Round . . . . .	RD	Spring . . . . .	SPR	Ultimate . . . . .	ULT
Round head . . . . .	RD HD	Square . . . . .	SQ	United States . . . . .	US
Rubber . . . . .	RUB	Square foot (feet) . . . . .	SF	United States of America	
Screw . . . . .	SCR	Square inch(es) . . . . .	SQ IN	Standards Institute . . . . .	ANSI
Screw threads:		Stainless steel . . . . .	SS	United States gage . . . . .	USG
American National coarse . . . . .	NC	Standard . . . . .	STD	Universal . . . . .	UNIV
American National fine . . . . .	NF	Standard cubic feet per minute . . . . .	SCFM	Unless otherwise specified . . . . .	UOS
American National extra fine . . . . .	NEF	Static pressure . . . . .	SP	Upper . . . . .	UPR
American National 8 pitch . . . . .	8N	Steel . . . . .	STL	Vacuum . . . . .	VAC
American National 12 pitch . . . . .	12N	Structure, Structural . . . . .	STRUCT	Velocity . . . . .	V or VEL
American National 16 pitch . . . . .	16N	Supply air . . . . .	SA	Vent through roof . . . . .	VTR
American Standard		Support . . . . .	SUPT	Versus . . . . .	VS
straight pipe coupling . . . . .	NPSC	Switch . . . . .	SW	Vertical . . . . .	VERT
American Standard taper pipe . . . . .	NPT	Symbol . . . . .	SYM	Volt(s) . . . . .	V
American Standard taper . . . . .	NPTF	Symmetrical . . . . .	SYM	Volume . . . . .	VOL
Unified screw thread coarse . . . . .	UNC	Synthetic . . . . .	SYN	Volume damper . . . . .	VD
Unified screw thread fine . . . . .	UNF	Tangent . . . . .	TAN	Water gauge . . . . .	WG
Unified screw thread extra fine . . . . .	UNEF	Technical . . . . .	TECH	Water line . . . . .	WL
Unified screw thread 8 thread . . . . .	8UN	Teeth . . . . .	T	Water pressure drop . . . . .	WPD
Unified screw thread 12 thread . . . . .	12UN	Temperature . . . . .	TEMP	Watt . . . . .	W
Unified screw thread 16 thread . . . . .	16UN	Tensile strength . . . . .	TS	Weight . . . . .	WT
Unified screw thread special . . . . .	UNS	Terminal . . . . .	TERM	Width . . . . .	W
Second . . . . .	(") or SEC	Theoretical . . . . .	THEO	With . . . . .	W/
Section . . . . .	SECT	Thickness . . . . .	THK	Without . . . . .	W/O
Sensible . . . . .	SENS	Thousand BTU per hour . . . . .	MBH	Wood . . . . .	WD
Serial, Series . . . . .	SER	Thread . . . . .	THD	Wood screw . . . . .	WD SCR
Sheet . . . . .	SH	Through . . . . .	THRU	Wrought iron . . . . .	WI
Side view . . . . .	SV	Tolerance . . . . .	TOL	Yard . . . . .	YD
Similar . . . . .	SIM	Total static pressure . . . . .	TSP	Year . . . . .	YR

**APPENDIX B  
CONVERSION CHARTS**

TABLE 1 INCHES TO MILLIMETERS							
in.	mm	in.	mm	in.	mm	in.	mm
1	25.4	26	660.4	51	1295.4	76	1930.4
2	50.8	27	685.8	52	1320.8	77	1955.8
3	76.2	28	711.2	53	1346.2	78	1981.2
4	101.6	29	736.6	54	1371.6	79	2006.6
5	127.0	30	762.0	55	1397.0	80	2032.0
6	152.4	31	787.4	56	1422.4	81	2057.4
7	177.8	32	812.8	57	1447.8	82	2082.8
8	203.2	33	838.2	58	1473.2	83	2108.2
9	228.6	34	863.6	59	1498.6	84	2133.6
10	254.0	35	889.0	60	1524.0	85	2159.0
11	279.4	36	914.4	61	1549.4	86	2184.4
12	304.8	37	939.8	62	1574.8	87	2209.8
13	330.2	38	965.2	63	1600.2	88	2235.2
14	355.6	39	990.6	64	1625.6	89	2260.6
15	381.0	40	1016.0	65	1651.0	90	2286.0
16	406.4	41	1041.4	66	1676.4	91	2311.4
17	431.8	42	1066.8	67	1701.8	92	2336.8
18	457.2	43	1092.2	68	1727.2	93	2362.2
19	482.6	44	1117.6	69	1752.6	94	2387.6
20	508.0	45	1143.0	70	1778.0	95	2413.0
21	533.4	46	1168.4	71	1803.4	96	2438.4
22	558.8	47	1193.8	72	1828.8	97	2463.8
23	584.2	48	1219.2	73	1854.2	98	2489.2
24	609.6	49	1244.6	74	1879.6	99	2514.6
25	635.0	50	1270.0	75	1905.0	100	2540.0

The above table is exact on the basis: 1 in. = 25.4 mm

TABLE 2 MILLIMETERS TO INCHES							
in.	mm	in.	mm	in.	mm	in.	mm
1	0.039370	26	1.023622	51	2.007874	76	2.992126
2	0.078740	27	1.062992	52	2.047244	77	3.031496
3	0.118110	28	1.102362	53	2.086614	78	3.070866
4	0.157480	29	1.141732	54	2.125984	79	3.110236
5	0.196850	30	1.181102	55	2.165354	80	3.149606
6	0.236220	31	1.220472	56	2.204724	81	3.188976
7	0.275591	32	1.259843	57	2.244094	82	3.228346
8	0.314961	33	1.299213	58	2.283465	83	3.267717
9	0.354331	34	1.338583	59	2.322835	84	3.307087
10	0.393701	35	1.377953	60	2.362205	85	3.346457
11	0.433071	36	1.417323	61	2.401575	86	3.385827
12	0.472441	37	1.456693	62	2.440945	87	3.425197
13	0.511811	38	1.496063	63	2.480315	88	3.464567
14	0.551181	39	1.535433	64	2.519685	89	3.503937
15	0.590551	40	1.574803	65	2.559055	90	3.543307
16	0.629921	41	1.614173	66	2.598425	91	3.582677
17	0.669291	42	1.653543	67	2.637795	92	3.622047
18	0.708661	43	1.692913	68	2.677165	93	3.661417
19	0.748031	44	1.732283	69	2.716535	94	3.700787
20	0.787402	45	1.771654	70	2.755906	95	3.740157
21	0.826772	46	1.811024	71	2.795276	96	3.779528
22	0.866142	47	1.850394	72	2.834646	97	3.818898
23	0.905512	48	1.889764	73	2.874016	98	3.858268
24	0.944882	49	1.929134	74	2.913386	99	3.897638
25	0.984252	50	1.968504	75	2.952756	100	3.937008

The above table is approximate on the basis: 1 in. = 25.4 mm, 1/25.4 = 0.039370078740+

TABLE 3 INCH/METRIC EQUIVALENTS							
Fraction	Decimal Equivalent		Fraction	Decimal Equivalent			
	Customary (in.)	Metric (mm)		Customary (in.)	Metric (mm)		
	1/64	.015625	0.3969	33/64	.515625	13.0969	
	1/32	.03125	0.7938	17/32	.53125	13.4938	
		3/64	.046875	1.1906	35/64	.546875	13.8906
1/16		.0625	1.5875	9/16	.5625	14.2875	
	5/64	.078125	1.9844		37/64	.578125	14.6844
3/32		.09375	2.3813	19/32	.59375	15.0813	
	7/64	.109375	2.7781	5/8	.609375	15.4781	
1/8		.1250	3.1750		.6250	15.8750	
	9/64	.140625	3.5719		41/64	.640625	16.2719
	5/32	.15625	3.9688	21/32	.65625	16.6688	
	11/64	.171875	4.3656		43/64	.671875	17.0656
3/16		.1875	4.7625	11/16	.6875	17.4625	
	13/64	.203125	5.1594		45/64	.703125	17.8594
	7/32	.21875	5.5563	23/32	.71875	18.2563	
	15/64	.234375	5.9531		47/64	.734375	18.6531
1/4		.2500	6.3500	3/4	.7500	19.0500	
	17/64	.265625	6.7469		49/64	.765625	19.4469
	9/32	.28125	7.1438	25/32	.78125	19.8438	
	19/64	.296875	7.5406		51/64	.796875	20.2406
5/16		.3125	7.9375	13/16	.8125	20.6375	
	21/64	.328125	8.3384		53/64	.828125	21.0344
	11/32	.34375	8.7313	27/32	.84375	21.4313	
	23/64	.359375	9.1281		55/64	.859375	21.8281
3/8		.3750	9.5250	7/8	.8750	22.2250	
	25/64	.390625	9.9219		57/64	.890625	22.6219
	13/32	.40625	10.3188	29/32	.90625	23.0188	
	27/64	.421875	10.7156		59/64	.921875	23.4156
7/16		.4375	11.1125	15/16	.9375	23.8125	
	29/64	.453125	11.5094		61/64	.953125	24.2094
	15/32	.46875	11.9063	31/32	.96875	24.6063	
	31/64	.484375	12.3031		63/64	.984375	25.0031
1/2		.5000	12.7000	1	1.0000	25.4000	

## APPENDIX B CONVERSION CHARTS (Continued)

TABLE 4 INCH/METRIC—CONVERSION	
Measures of Length	
1 millimeter (mm)	= 0.03937 inch
1 centimeter (cm)	= 0.39370 inch
1 meter (m)	= 39.37008 inches = 3.2808 feet = 1.0936 yards
1 kilometer (km)	= 0.6214 mile
1 inch	= 25.4 millimeters (mm) = 2.54 centimeters (cm)
1 foot	= 304.8 millimeters (mm) = 0.3048 meter (m)
1 yard	= 0.9144 meter (m)
1 mile	= 1.609 kilometers (km)
Measures of Area	
1 square millimeter	= 0.00155 square inch
1 square centimeter	= 0.155 square inch
1 square meter	= 10.764 square feet = 1.196 square yards
1 square kilometer	= 0.3861 square mile
1 square inch	= 645.2 square millimeters = 6.452 square centimeters
1 square foot	= 929 square centimeters = 0.0929 square meter
1 square yard	= 0.836 square meter
1 square mile	= 2.5899 square kilometers
Measures of Capacity (Dry)	
1 cubic centimeter (cm <sup>3</sup> )	= 0.061 cubic inch
1 liter	= 0.0353 cubic foot = 61.023 cubic inches
1 cubic meter (m <sup>3</sup> )	= 35.315 cubic feet = 1.308 cubic yards
1 cubic inch	= 16.38706 cubic centimeters (cm <sup>3</sup> )
1 cubic foot	= 0.02832 cubic meter (m <sup>3</sup> ) = 28.317 liters
1 cubic yard	= 0.7646 cubic meter (m <sup>3</sup> )
Measures of Capacity (Liquid)	
1 liter	= 1.0567 U.S. quarts = 0.2642 U.S. gallon = 0.2200 Imperial gallon
1 cubic meter (m <sup>3</sup> )	= 264.2 U.S. gallons = 219.969 Imperial gallons
1 U.S. quart	= 0.946 liter
1 Imperial quart	= 1.136 liters
1 U.S. gallon	= 3.785 liters
1 Imperial gallon	= 4.546 liters
Measures of Weight	
1 gram (g)	= 15.432 grains = 0.03215 ounce troy = 0.03527 ounce avoirdupois
1 kilogram (kg)	= 35.274 ounces avoirdupois = 2.2046 pounds
1000 kilograms (kg)	= 1 metric ton (t) = 1.1023 tons of 2000 pounds = 0.9842 ton of 2240 pounds
1 ounce avoirdupois	= 28.35 grams (g)
1 ounce troy	= 31.103 grams (g)
1 pound	= 453.6 grams = 0.4536 kilogram (kg)
1 ton of 2240 pounds	= 1016 kilograms (kg) = 1.016 metric tons
1 grain	= 0.0648 gram (g)
1 metric ton	= 0.9842 ton of 2240 pounds = 2204.6 pounds

**APPENDIX C  
MATHEMATICAL RULES RELATED TO THE CIRCLE**

MATHEMATICAL RULES RELATED TO THE CIRCLE			
<b>To Find Circumference—</b>			
Multiply diameter by	3.1416 .....	Or divide diameter by	0.3183
<b>To Find Diameter—</b>			
Multiply circumference by	0.3183 .....	Or divide circumference by	3.1416
<b>To Find Radius—</b>			
Multiply circumference by	0.15915 .....	Or divide circumference by	6.28318
<b>To Find Side of an Inscribed Square—</b>			
Multiply diameter by	0.7071		
Or multiply circumference by	0.2251 .....	Or divide circumference by	4.4428
<b>To Find Side of an Equal Square—</b>			
Multiply diameter by	0.8862 .....	Or divide diameter by	1.1284
Or multiply circumference by	0.2821 .....	Or divide circumference by	3.545
<b>Square—</b>			
A side multiplied by	1.4142	equals diameter of its circumscribing circle.	
A side multiplied by	4.443	equals circumference of its circumscribing circle.	
A side multiplied by	1.128	equals diameter of an equal circle.	
A side multiplied by	3.547	equals circumference of an equal circle.	
<b>To Find the Area of a Circle—</b>			
Multiply circumference by one-quarter of the diameter.			
Or multiply the square of diameter by	0.7854		
Or multiply the square of circumference by	0.7958		
Or multiply the square of 1/2 diameter by	3.1416		
<b>To Find the Surface of a Sphere or Globe—</b>			
Multiply the diameter by the circumference.			
Or multiply the square of diameter by	3.1416		
Or multiply four times the square of radius by	3.1416		

# APPENDIX D GENERAL APPLICATIONS OF SAE STEELS

Application	SAE No.	Application	SAE No.
Adapters .....	1145	Chain pins, transmission.....	4320
Agricultural steel .....	1070	" " " .....	4815
" " " .....	1080	" " " .....	4820
Aircraft forgings .....	4140	Chains, transmission .....	3135
Axles, front or rear .....	1040	" " " .....	3140
" " " .....	4140	Clutch disks .....	1060
Axle shafts.....	1045	" " " .....	1070
" " " .....	2340	" " " .....	1085
" " " .....	2345	Clutch springs .....	1060
" " " .....	3135	Coil springs .....	4063
" " " .....	3140	Cold-headed bolts .....	4042
" " " .....	3141	Cold-heading steel.....	30905
" " " .....	4063	Cold-heading wire or rod.....	rimmed*
" " " .....	4340	" " " .....	1035
Ball-bearing races .....	52100	Cold-rolled steel .....	1070
Balls for ball bearings.....	52100	Connecting-rods .....	1040
Body stock for cars .....	rimmed*	" " " .....	3141
Bolts, anchor .....	1040	Connecting-rod bolts.....	3130
Bolts and screws .....	1035	Corrosion resisting.....	51710
Bolts, cold-headed.....	4042	" " " .....	30805
Bolts, connecting-rod.....	3130	Covers, transmission .....	rimmed*
Bolts, heat-treated .....	2330	Crankshafts.....	1045
Bolts, heavy-duty .....	4815	" " " .....	1145
" " " .....	4820	" " " .....	3135
" " " .....	3130	" " " .....	3140
Brake levers.....	1030	" " " .....	3141
" " " .....	1040	Crankshafts, Diesel engine .....	4340
Bumper bars.....	1085	Cushion, springs.....	1060
Cams, free-wheeling .....	4615	Cutlery, stainless.....	51335
" " " .....	4620	Cylinder studs .....	3130
Camshafts .....	1020	Deep-drawing steel.....	rimmed*
" " " .....	1040	" " " .....	30905
Carburized parts.....	1020	Differential gears.....	4023
" " " .....	1022	Disks, clutch.....	1070
" " " .....	1024	" " " .....	1060
" " " .....	1320	Ductile steel .....	30905
" " " .....	2317	Fan blades .....	1020
" " " .....	2515	Fatigue resisting .....	4340
" " " .....	3310	" " " .....	4640
" " " .....	3115	Fender stock for cars.....	rimmed*
" " " .....	3120	Forgings, aircraft.....	4140
" " " .....	4023	Forgings, carbon steel.....	1040
" " " .....	4032	" " " .....	1045
" " " .....	1117	Forgings, heat-treated.....	3240
" " " .....	1118	" " " .....	5140

Application	SAE No.	Application	SAE No.
Forgings, heat-treated .....	6150	Key stock .....	1030
Forgings, high-duty .....	6150	" " " .....	2330
Forgings, small or medium .....	1035	" " " .....	3130
Forgings, large .....	1036	Leaf springs .....	1085
Free-cutting carbon steel.....	1111	" " " .....	9260
" " " .....	1113	Levers, brake .....	1030
Free-cutting chro.-ni. steel.....	30615	" " " .....	1040
Free-cutting mang. steel.....	1132	Levers, gear shift .....	1030
" " " .....	1137	Levers, heat-treated.....	2330
Gears, carburized .....	1320	Lock-washers .....	1060
" " " .....	2317	Mower knives .....	1085
" " " .....	3115	Mower sections .....	1070
" " " .....	3120	Music wire.....	1085
" " " .....	3310	Nuts .....	3130
" " " .....	4119	Nuts, heat-treated.....	2330
" " " .....	4125	Oil-pans, automobile .....	rimmed*
" " " .....	4320	Pinions, carburized.....	3115
" " " .....	4615	" " " .....	3120
" " " .....	4620	" " " .....	4320
" " " .....	4815	Piston-pins .....	3115
" " " .....	4820	" " " .....	3120
Gears, heat-treated .....	2345	Plow beams .....	1070
Gears, car and truck .....	4027	Plow disks .....	1080
" " " .....	4032	Plow shares .....	1080
Gears, cyanide-hardening .....	5140	Propeller shafts.....	2340
Gears, differential .....	4023	" " " .....	2345
Gears, high duty .....	4640	" " " .....	4140
" " " .....	6150	Races, ball-bearing .....	52100
Gears, oil-hardening.....	3145	Ring gears.....	3115
" " " .....	3150	" " " .....	3120
" " " .....	4340	" " " .....	4119
" " " .....	5150	Rings, snap.....	1060
Gears, ring.....	1045	Rivets .....	rimmed*
" " " .....	3115	Rod and wire.....	killed*
" " " .....	3120	Rod, cold-heading .....	1035
" " " .....	4119	Roller bearings.....	4815
Gears, transmission .....	3115	Rollers for bearings.....	52100
" " " .....	3120	Screws and bolts .....	1035
" " " .....	4119	Screw stock, Bessemer .....	1111
Gears, truck and bus .....	3310	" " " .....	1112
" " " .....	4320	" " " .....	1113
Gear shift levers .....	1030	Screw stock, open hearth .....	1115
Harrow disks .....	1080	Screws, heat-treated.....	2330
" " " .....	1095	Seat springs.....	1095
Hay-rake teeth .....	1095	Shafts, axle.....	1045

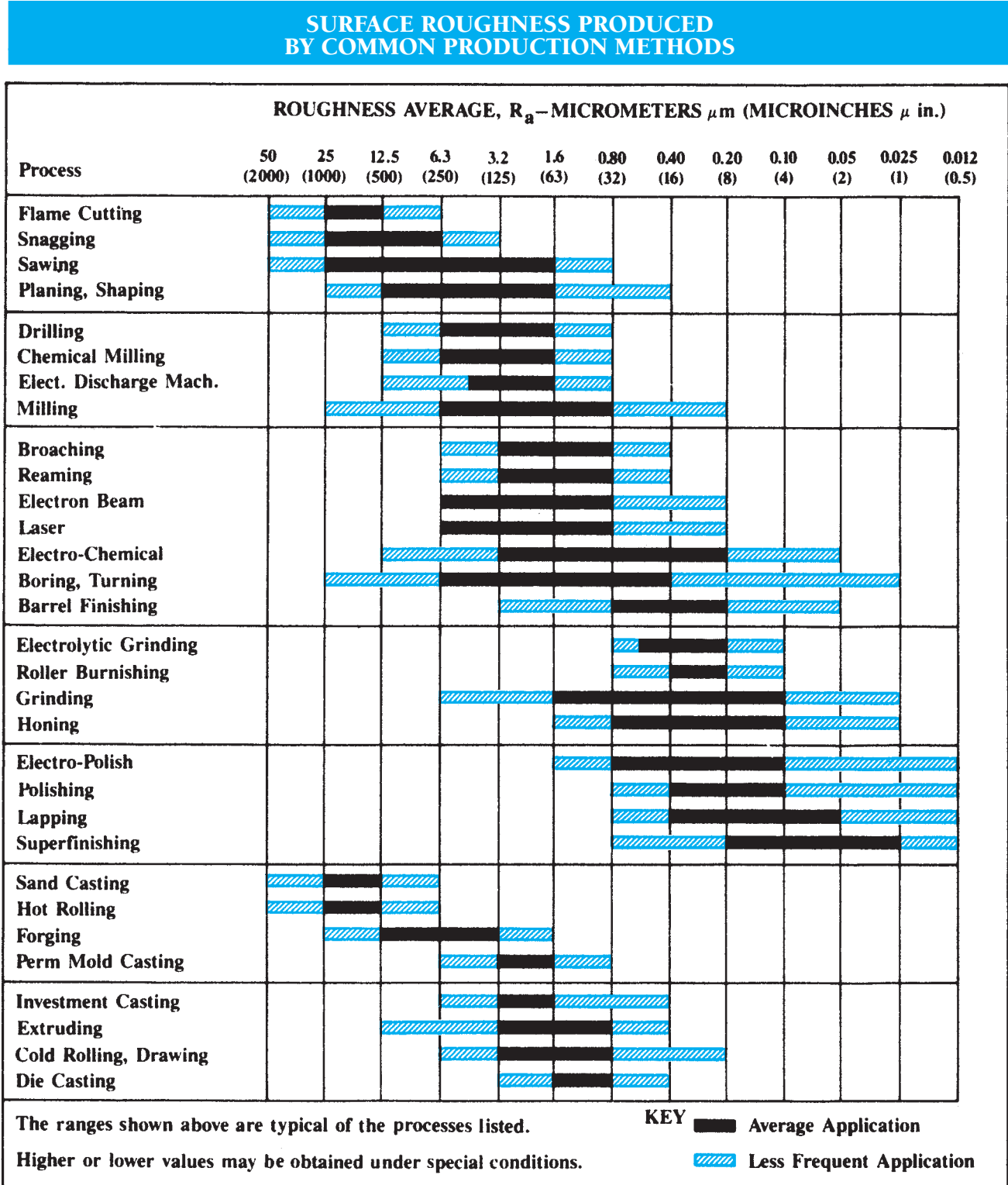
Application	SAE No.	Application	SAE No.
Shafts, cyanide-hardening ..	5140	Steel, cold-heading.....	30905
Shafts, heavy-duty .....	4340	Steel, free-cutting carbon .....	11111
" " " .....	6150	" " " .....	1113
" " " .....	4615	Steel, free-cutting chro.-ni. ....	30615
" " " .....	4620	Steel, free-cutting mang. ....	1132
Shafts, oil-hardening .....	5150	" " " .....	0000
Shafts, propeller .....	2340	Steel, minimum distortion.....	4615
" " " .....	2345	" " " .....	4620
" " " .....	4140	" " " .....	4640
Shafts, transmission .....	4140	Steel, soft ductile .....	30905
Sheets and strips .....	rimmed*	Steering arms.....	4042
Snap rings.....	1060	Steering-arm bolts.....	3130
Spline shafts .....	1045	Steering knuckles.....	3141
" " " .....	1320	Steering-knuckle pins.....	4815
" " " .....	2340	" " " .....	4820
" " " .....	2345	Studs .....	1040
" " " .....	3115	" " " .....	1111
" " " .....	3120	Studs, cold-headed .....	4042
" " " .....	3135	Studs, cylinder .....	3130
" " " .....	3140	Studs, heat-treated .....	2330
" " " .....	4023	Studs, heavy-duty .....	4815
" " " .....	1060	" " " .....	4820
Spring clips .....	1060	Tacks .....	rimmed*
Springs, coil .....	1095	Thrust washers .....	1060
" " " .....	4063	Thrust washers, oil-harden .....	5150
" " " .....	6150	Transmission shafts .....	4140
Springs, clutch .....	1060	Tubing .....	1040
Springs, cushion.....	1060	Tubing, front axle .....	4140
Springs, leaf .....	1085	Tubing, seamless .....	1030
" " " .....	1095	Tubing, welded .....	1020
" " " .....	4063	Universal joints.....	1145
" " " .....	4068	Valve springs .....	1060
" " " .....	9260	Washers, lock .....	1060
" " " .....	6150	Welded structures .....	30705
Springs, hard-drawn coiled ..	1066	Wire and rod .....	killed*
Springs, oil-hardening.....	5150	Wire, cold-heading.....	rimmed*
Springs, oil-tempered wire..	1066	" " " .....	1035
Springs, seat.....	1095	Wire, hard-drawn spring.....	1045
Springs, valve.....	1060	" " " .....	1055
Spring wire .....	1045	Wire, music .....	1085
Spring wire, hard-drawn .....	1055	Wire, oil-tempered spring.....	1055
Spring wire, oil-tempered ..	1055	Wrist-pins, automobile .....	1020
Stainless irons.....	51210	Yokes .....	1145
" " " .....	51710		
Steel, cold-rolled .....	1070		

\*The "rimmed" and "killed" steels listed are in the SAE 1008, 1010, and 1015 group. See general description of these steels.

Reprinted by permission from Oberg, Jones, and Horton, *Machinery's Handbook*, 24th ed. (New York: Industrial Press, Inc., 1992), table 6, pp. 382–84.



**APPENDIX E**  
**SURFACE ROUGHNESS PRODUCED BY COMMON PRODUCTION METHODS**



Reprinted by permission from Oberg, Jones, and Horton, *Machinery's Handbook*, 24th ed. (New York: Industrial Press, Inc., 1992), figure 5, p. 672.

## APPENDIX F WIRE GAGES (INCHES)

WIRE GAGES (INCHES)								
No. of Wire Gage	American Wire or Brown & Sharpe Gage	Steel Wire Gage (U.S.)	British Standard Wire Gage (Imperial Wire Gage)	Music or Piano Wire Gage	Birmingham or Stub's Iron Wire Gage	Stub's Steel Wire Gage	No. of Wire Gage	Stub's Steel Wire Gage
7/0	...	.4900	.5000	...	...	...	51	.066
6/0	.5800	.4615	.4640	.004	...	...	52	.063
5/0	.5165	.4305	.4320	.005	.5000	...	53	.058
4/0	.4600	.3938	.4000	.006	.4540	...	54	.055
3/0	.4096	.3625	.3720	.007	.4250	...	55	.050
2/0	.3648	.3310	.3480	.008	.3800	...	56	.045
1/0	.3249	.3065	.3240	.009	.3400	...	57	.042
1	.2893	.2830	.3000	.010	.3000	.227	58	.041
2	.2576	.2625	.2760	.011	.2840	.219	59	.040
3	.2294	.2437	.2520	.012	.2590	.212	60	.039
4	.2043	.2253	.2320	.013	.2380	.207	61	.038
5	.1819	.2070	.2120	.014	.2200	.204	62	.037
6	.1620	.1920	.1920	.016	.2030	.201	63	.036
7	.1443	.1770	.1760	.018	.1800	.199	64	.035
8	.1285	.1620	.1600	.020	.1650	.197	65	.033
9	.1144	.1483	.1440	.022	.1480	.194	66	.032
10	.1019	.1350	.1280	.024	.1340	.191	67	.031
11	.0907	.1205	.1160	.026	.1200	.188	68	.030
12	.0808	.1055	.1040	.029	.1090	.185	69	.029
13	.0720	.0915	.0920	.031	.0950	.182	70	.027
14	.0641	.0800	.0800	.033	.0830	.180	71	.026
15	.0571	.0720	.0720	.035	.0720	.178	72	.024
16	.0508	.0625	.0640	.037	.0650	.175	73	.023
17	.0453	.0540	.0560	.039	.0580	.172	74	.022
18	.0403	.0475	.0480	.041	.0490	.168	75	.020
19	.0359	.0410	.0400	.043	.0420	.164	76	.018
20	.0320	.0348	.0360	.045	.0350	.161	77	.016
21	.0285	.0318	.0320	.047	.0320	.157	78	.015
22	.0253	.0286	.0280	.049	.0280	.155	79	.014
23	.0226	.0258	.0240	.051	.0250	.153	80	.013
24	.0201	.0230	.0220	.055	.0220	.151	...	...
25	.0179	.0204	.0200	.059	.0200	.148	...	...
26	.0159	.0181	.0180	.063	.0180	.146	...	...
27	.0142	.0173	.0164	.067	.0160	.143	...	...
28	.0126	.0162	.0149	.071	.0140	.139	...	...
29	.0113	.0150	.0136	.075	.0130	.134	...	...
30	.0100	.0140	.0124	.080	.0120	.127	...	...
31	.00893	.0132	.0116	.085	.0100	.120	...	...
32	.00795	.0128	.0108	.090	.0090	.115	...	...
33	.00708	.0118	.0100	.095	.0080	.112	...	...
34	.00630	.0104	.0092	.100	.0070	.110	...	...
35	.00561	.0095	.0084	.106	.0050	.108	...	...
36	.00500	.0090	.0076	.112	.0040	.106	...	...
37	.00445	.0085	.0068	.118	...	.103	...	...
38	.00396	.0080	.0060	.124	...	.101	...	...
39	.00353	.0075	.0052	.130	...	.099	...	...
40	.00314	.0070	.0048	.138	...	.097	...	...
41	.00280	.0066	.0044	.146	...	.095	...	...
42	.00249	.0062	.0040	.154	...	.092	...	...
43	.00222	.0060	.0036	.162	...	.088	...	...
44	.00198	.0058	.0032	.170	...	.085	...	...
45	.00176	.0055	.0028	.180	...	.081	...	...
46	.00157	.0052	.0024	...	...	.079	...	...
47	.00140	.0050	.0020	...	...	.077	...	...
48	.00124	.0048	.0016	...	...	.075	...	...
49	.00111	.0046	.0012	...	...	.072	...	...
50	.00099	.0044	.0010	...	...	.069	...	...

## APPENDIX G SHEET METAL GAGES (INCHES)

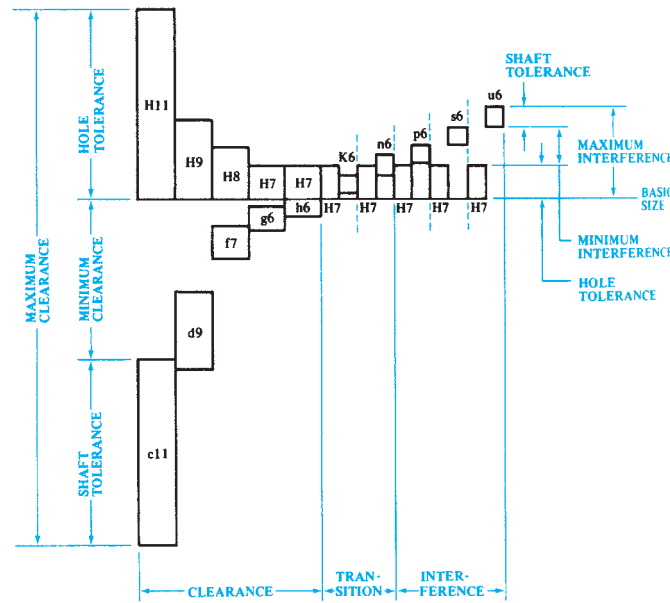
SHEET METAL GAGES (INCHES)									
No. of Sheet Metal Gage	Manufacturers' Standard Gage for Steel	Birmingham Gage (B.G.) for Sheets, Hoops	Galvanized Sheet Gage	Zinc Gage	No. of Sheet Metal Gage	Manufacturers' Standard Gage for Steel	Birmingham Gage (B.G.) for Sheets, Hoops	Galvanized Sheet Gage	Zinc Gage
15/0	...	1.000	...	...	20	.0359	.0392	.0396	.070
14/0	...	.9583	...	...	21	.0329	.0349	.0366	.080
13/0	...	.9167	...	...	22	.0299	.03125	.0336	.090
12/0	...	.8750	...	...	23	.0269	.02782	.0306	.100
11/0	...	.8333	...	...	24	.0239	.02476	.0276	.125
10/0	...	.7917	...	...	25	.0209	.02204	.0247	...
9/0	...	.7500	...	...	26	.0179	.01961	.0217	...
8/0	...	.7083	...	...	27	.0164	.01745	.0202	...
7/0	...	.6666	...	...	28	.0149	.01562	.0187	...
6/0	...	.6250	...	...	29	.0135	.01390	.0172	...
5/0	...	.5883	...	...	30	.0120	.01230	.0157	...
4/0	...	.5416	...	...	31	.0105	.01100	.0142	...
3/0	...	.5000	...	...	32	.0097	.00980	.0134	...
2/0	...	.4452	...	...	33	.0090	.00870	...	...
1/0	...	.3964	...	...	34	.0082	.00770	...	...
1	...	.3532	...	...	35	.0075	.00690	...	...
2	...	.3147	...	...	36	.0067	.00610	...	...
3	.2391	.2804	...	.006	37	.0064	.00540	...	...
4	.2242	.2500	...	.008	38	.0060	.00480	...	...
5	.2092	.2225	...	.010	39	...	.00430	...	...
6	.1943	.1981	...	.012	40	...	.00386	...	...
7	.1793	.1764	...	.014	41	...	.00343	...	...
8	.1644	.1570	.1681	.016	42	...	.00306	...	...
9	.1495	.1398	.1532	.018	43	...	.00272	...	...
10	.1345	.1250	.1382	.020	44	...	.00242	...	...
11	.1196	.1113	.1233	.024	45	...	.00215	...	...
12	.1046	.0991	.1084	.028	46	...	.00192	...	...
13	.0897	.0882	.0934	.032	47	...	.00170	...	...
14	.0747	.0785	.0785	.036	48	...	.00152	...	...
15	.0673	.0699	.0710	.040	49	...	.00135	...	...
16	.0598	.0625	.0635	.045	50	...	.00120	...	...
17	.0538	.0556	.0575	.050	51	...	.00107	...	...
18	.0478	.0495	.0516	.055	52	...	.00095	...	...
19	.0418	.0440	.0456	.060	...	...	...	...	...

## APPENDIX H SHEET METAL THICKNESSES (MILLIMETERS)

SHEET METAL THICKNESSES (MILLIMETERS)					
Preferred Thickness	Second Preference	Third Preference	Preferred Thickness	Second Preference	Third Preference
0.050	...	...	...	...	3.6
0.060	...	...	...	3.8	...
0.080	...	...	4.0	...	...
0.10	...	...	...	4.2	...
0.12	...	...	...	4.5	...
...	0.14	...	...	4.8	...
0.16	...	...	5.0	...	...
...	0.18	...	...	5.5	...
0.20	...	...	6.0	...	...
...	0.22	...	...	...	6.5
0.25	...	...	...	7.0	...
...	0.28	...	...	...	7.5
0.30	...	...	8.0	...	...
...	0.35	...	...	9.0	...
0.40	...	...	10	...	...
...	0.45	...	...	11	...
0.50	...	...	12	...	...
...	0.55	...	...	14	...
0.60	...	...	16	...	...
...	0.65	...	...	18	...
...	0.70	...	20	...	...
...	...	0.75	...	22	...
0.80	...	...	25	...	...
...	...	0.85	...	28	...
...	0.90	...	30	...	...
...	...	0.95	...	32	...
1.0	...	...	35	...	...
...	...	1.05	...	38	...
...	1.1	...	40	...	...
1.2	...	...	...	45	...
...	...	1.3	50	...	...
...	1.4	...	...	55	...
...	...	1.5	60	...	...
1.6	...	...	...	70	...
...	...	1.7	80	...	...
...	1.8	...	...	90	...
...	...	1.9	100	...	...
2.0	...	...	...	110	...
...	...	2.1	120	...	...
...	2.2	...	...	130	...
...	...	2.4	140	...	...
2.5	...	...	...	150	...
...	...	2.6	160	...	...
...	2.8	...	180	...	...
3.0	...	...	200	...	...
...	3.2	...	250	...	...
...	...	3.4	300	...	...
3.5	...	...	...	...	...

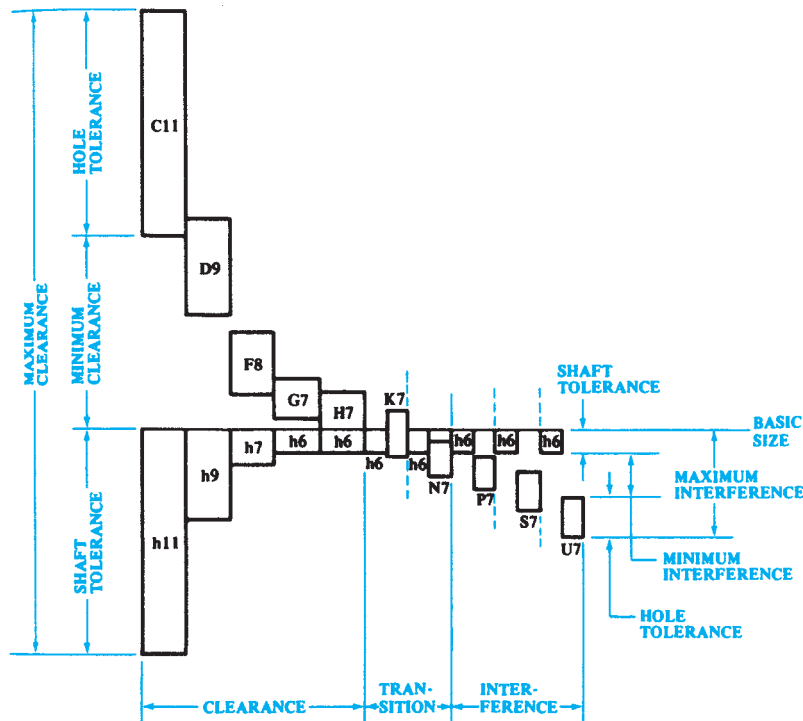
**APPENDIX I  
STANDARD ALLOWANCES, TOLERANCES, AND FITS**

**TABLE 5 ALLOWANCES AND TOLERANCES**



**Preferred Hole Basis Fits**

Reprinted by permission from Oberg, Jones, and Horton, *Machinery's Handbook*, 24th ed. (New York: Industrial Press, Inc., 1992), figure 2, p. 662.



**Preferred Shaft Basis Fits**

Reprinted by permission from Oberg, Jones, and Horton, *Machinery's Handbook*, 24th ed. (New York: Industrial Press, Inc., 1992), figure 3, p. 623.

## APPENDIX I (Continued)

TABLE 5 (CONTINUED)

ISO SYMBOL		DESCRIPTION
Hole Basis	Shaft Basis	
H11/c11	C11/h11	<i>Loose running</i> fit for wide commercial tolerances or allowances on external members.
H9/d9	D9/h9	<i>Free running</i> fit not for use where accuracy is essential, but good for large temperature variations, high running speeds, or heavy journal pressures.
H8/f7	F8/h7	<i>Close running</i> fit for running on accurate machines and for accurate location at moderate speeds and journal pressures.
H7/g6	G7/h6	<i>Sliding</i> fit not intended to run freely, but to move and turn freely and locate accurately.
H7/h6	H7/h6	<i>Locational clearance</i> fit provides snug fit for locating stationary parts; but can be freely assembled and disassembled.
H7/k6	K7/h6	<i>Locational transition</i> fit for accurate location, a compromise between clearance and interference.
H7/n6	N7/h6	<i>Locational transition</i> fit for more accurate location where greater interference is permissible.
H7/p6 <sup>1</sup>	P7/h6	<i>Locational interference</i> fit for parts requiring rigidity and alignment with prime accuracy of location but without special bore pressure requirements.
H7/s6	S7/h6	<i>Medium drive</i> fit for ordinary steel parts or shrink fits on light sections, the tightest fit usable with cast iron.
H7/u6	U7/h6	<i>Force</i> fit suitable for parts which can be highly stressed or for shrink fits where the heavy pressing forces required are impractical.

<sup>1</sup> Transition fit for basic sizes in range from 0 through 3 mm.

### Description of Preferred Fits

Reprinted by permission from Oberg, Jones, and Horton, *Machinery's Handbook*, 24th ed. (New York: Industrial Press, Inc., 1992), figure 4, p. 624.

APPENDIX I (Continued)

TABLE 6 AMERICAN NATIONAL STANDARD FITS

RUNNING AND SLIDING FITS

Limits are in thousandths of an inch.

Limits for hole and shaft are applied algebraically to the basic size to obtain the limits of size for the parts.

Data in **boldface** are in accordance with ABC agreements.

Symbols H5, g5, etc., are Hole and Shaft designations used in ABC System (Appendix I).

Nominal Size Range Inches		Class RC 1			Class RC 2			Class RC 3			Class RC 4		
		Limits of Clearance	Standard Limits		Limits of Clearance	Standard Limits		Limits of Clearance	Standard Limits		Limits of Clearance	Standard Limits	
			Hole H5	Shaft g4		Hole H6	Shaft g5		Hole H7	Shaft f6		Hole H8	Shaft f7
Over	To												
0	- 0.12	0.1	+ 0.2	- 0.1	0.1	+ 0.25	- 0.1	0.3	+ 0.4	- 0.3	0.3	+ 0.6	- 0.3
		0.45	0	- 0.25	0.55	0	- 0.3	0.95	0	- 0.55	1.3	0	- 0.7
0.12	- 0.24	0.15	+ 0.2	- 0.15	0.15	+ 0.3	- 0.15	0.4	+ 0.5	- 0.4	0.4	+ 0.7	- 0.4
		0.5	0	- 0.3	0.65	0	- 0.35	1.12	0	- 0.7	1.6	0	- 0.9
0.24	- 0.40	0.2	0.25	- 0.2	0.2	+ 0.4	- 0.2	0.5	+ 0.6	- 0.5	0.5	+ 0.9	- 0.5
		0.6	0	- 0.35	0.85	0	- 0.45	1.5	0	- 0.9	2.0	0	- 1.1
0.40	- 0.71	0.25	+ 0.3	- 0.25	0.25	+ 0.4	- 0.25	0.6	+ 0.7	- 0.6	0.6	+ 1.0	- 0.6
		0.75	0	- 0.45	0.95	0	- 0.55	1.7	0	- 1.0	2.3	0	- 1.3
0.71	- 1.19	0.3	+ 0.4	- 0.3	0.3	+ 0.5	- 0.3	0.8	+ 0.8	- 0.8	0.8	+ 1.2	- 0.8
		0.95	0	- 0.55	1.2	0	- 0.7	2.1	0	- 1.3	2.8	0	- 1.6
1.19	- 1.97	0.4	+ 0.4	- 0.4	0.4	+ 0.6	- 0.4	1.0	+ 1.0	- 1.0	1.0	+ 1.6	- 1.0
		1.1	0	- 0.7	1.4	0	- 0.8	2.6	0	- 1.6	3.6	0	- 2.0
1.97	- 3.15	0.4	+ 0.5	- 0.4	0.4	+ 0.7	- 0.4	1.2	+ 1.2	- 1.2	1.2	+ 1.8	- 1.2
		1.2	0	- 0.7	1.6	0	- 0.9	3.1	0	- 1.9	4.2	0	- 2.4
3.15	- 4.73	0.5	+ 0.6	- 0.5	0.5	+ 0.9	- 0.5	1.4	+ 1.4	- 1.4	1.4	+ 2.2	- 1.4
		1.5	0	- 0.9	2.0	0	- 1.1	3.7	0	- 2.3	5.0	0	- 2.8
4.73	- 7.09	0.6	+ 0.7	- 0.6	0.6	+ 1.0	- 0.6	1.6	+ 1.6	- 1.6	1.6	+ 2.5	- 1.6
		1.8	0	- 1.1	2.3	0	- 1.3	4.2	0	- 2.6	5.7	0	- 3.2
7.09	- 9.85	0.6	+ 0.8	- 0.6	0.6	+ 1.2	- 0.6	2.0	+ 1.8	- 2.0	2.0	+ 2.8	- 2.0
		2.0	0	- 1.2	2.6	0	- 1.4	5.0	0	- 3.2	6.6	0	- 3.8
9.85	- 12.41	0.8	+ 0.9	- 0.8	0.8	+ 1.2	- 0.8	2.5	+ 2.0	- 2.5	2.5	+ 3.0	- 2.5
		2.3	0	- 1.4	2.9	0	- 1.7	5.7	0	- 3.7	7.5	0	- 4.5
12.41	- 15.75	1.0	+ 1.0	- 1.0	1.0	+ 1.4	- 1.0	3.0	+	- 3.0	3.0	+ 3.5	- 3.0
		2.7	0	- 1.7	3.4	0	- 2.0	6.6	0	- 4.4	8.7	0	- 5.2
15.75	- 19.69	1.2	+ 1.0	- 1.2	1.2	+ 1.6	- 1.2	4.0	+ 1.6	- 4.0	4.0	+ 4.0	- 4.0
		3.0	0	- 2.0	3.8	0	- 2.2	8.1	0	- 5.6	10.5	0	- 6.5
19.69	- 30.09	1.6	+ 1.2	- 1.6	1.6	+ 2.0	- 1.6	5.0	+ 3.0	- 5.0	5.0	+ 5.0	- 5.0
		3.7	0	- 2.5	4.8	0	- 2.8	10.0	0	- 7.0	13.0	0	- 8.0
30.09	- 41.49	2.0	+ 1.6	- 2.0	2.0	+ 2.5	- 2.0	6.0	+ 4.0	- 6.0	6.0	+ 6.0	- 6.0
		4.6	0	- 3.0	6.1	0	- 3.6	12.5	0	- 8.5	16.0	0	-10.0
41.49	- 56.19	2.5	+ 2.0	- 2.5	2.5	+ 3.0	- 2.5	8.0	+ 5.0	- 8.0	8.0	+ 8.0	- 8.0
		5.7	0	- 3.7	7.5	0	- 4.5	16.0	0	-11.0	21.0	0	-13.0
56.19	- 76.39	3.0	+ 2.5	- 3.0	3.0	+ 4.0	- 3.0	10.0	+ 6.0	-10.0	10.0	+10.0	-10.0
		7.1	0	- 4.6	9.5	0	- 5.5	20.0	0	-14.0	26.0	0	-16.0
76.39	-100.9	4.0	+ 3.0	- 4.0	4.0	+ 5.0	- 4.0	12.0	+ 8.0	-12.0	12.0	+12.0	-12.0
		9.0	0	- 6.0	12.0	0	- 7.0	25.0	0	-17.0	32.0	0	-20.0
100.9	-131.9	5.0	+ 4.0	- 5.0	5.0	+ 6.0	- 5.0	16.0	+10.0	-16.0	16.0	+16.0	-16.0
		11.5	0	- 7.5	15.0	0	- 9.0	32.0	0	-22.0	36.0	0	-26.0
131.9	-171.9	6.0	+ 5.0	- 6.0	6.0	+ 8.0	- 6.0	18.0	+ 8.0	-18.0	18.0	+20.0	-18.0
		14.0	0	- 9.0	19.0	0	-11.0	38.0	0	-26.0	50.0	0	-30.0
171.9	-200	8.0	+ 6.0	- 8.0	8.0	+10.0	- 8.0	22.0	+16.0	-22.0	22.0	+25.0	-22.0
		18.0	0	-12.0	22.0	0	-12.0	48.0	0	-32.0	63.0	0	-38.0

APPENDIX I (Continued)

TABLE 6 (CONTINUED)—AMERICAN NATIONAL STANDARD FITS

RUNNING AND SLIDING FITS (continued)

Limits are in thousandths of an inch.

Limits for hole and shaft are applied algebraically to the basic size to obtain the limits of size for the parts.

Data in **boldface** are in accordance with ABC agreements.

Symbols H8, e7, etc., are Hole and Shaft designations used in ABC System (Appendix I).

Class RC 5			Class RC 6			Class RC 7			Class RC 8			Class RC 9			Nominal Size Range Inches	
Limits of Clearance	Standard Limits		Limits of Clearance	Standard Limits		Limits of Clearance	Standard Limits		Limits of Clearance	Standard Limits		Limits of Clearance	Standard Limits			
	Hole H8	Shaft e7		Hole H9	Shaft e8		Hole H9	Shaft d8		Hole H10	Shaft c9		Hole H11	Shaft		
0.6 1.6	+ 0.6 - 0	- 0.6 - 1.0	0.6 2.2	+ 1.0 0	- 0.6 - 1.2	1.0 2.6	+ 1.0 0	- 1.0 - 1.6	2.5 5.1	+ 1.6 0	- 2.5 - 3.5	4.0 8.1	+ 2.5 0	- 4.0 - 5.6	0	- 0.12
0.8 2.0	+ 0.7 - 0	- 0.8 - 1.3	0.8 2.7	+ 1.2 0	- 0.8 - 1.5	1.2 3.1	+ 1.2 0	- 1.2 - 1.9	2.8 5.8	+ 1.8 0	- 2.8 - 4.0	4.5 9.0	+ 3.0 0	- 4.5 - 6.0	0.12	- 0.24
1.0 2.5	+ 0.9 - 0	- 1.0 - 1.6	1.0 3.3	+ 1.4 0	- 1.0 - 1.9	1.6 3.9	+ 1.4 0	- 1.6 - 2.5	3.0 6.6	+ 2.2 0	- 3.0 - 4.4	5.0 10.7	+ 3.5 0	- 5.0 - 7.2	0.24	- 0.40
1.2 2.9	+ 1.0 - 0	- 1.2 - 1.9	1.2 3.8	+ 1.6 0	- 1.2 - 2.2	2.0 4.6	+ 1.6 0	- 2.0 - 3.0	3.5 7.9	+ 2.8 0	- 3.5 - 5.1	6.0 12.8	+ 4.0 0	- 6.0 - 8.8	0.40	- 0.71
1.6 3.6	+ 1.2 - 0	- 1.6 - 2.4	1.6 4.8	+ 2.0 0	- 1.6 - 2.8	2.5 5.7	+ 2.0 0	- 2.5 - 3.7	4.5 10.0	+ 3.5 0	- 4.5 - 6.5	7.0 15.5	+ 5.0 0	- 7.0 - 10.5	0.71	- 1.19
2.0 4.6	+ 1.6 - 0	- 2.0 - 3.0	2.0 6.1	+ 2.5 0	- 2.0 - 3.6	3.0 7.1	+ 2.5 0	- 3.0 - 4.6	5.0 11.5	+ 4.0 0	- 5.0 - 7.5	8.0 18.0	+ 6.0 0	- 8.0 - 12.0	1.19	- 1.97
2.5 5.5	+ 1.8 - 0	- 2.5 - 3.7	2.5 7.3	+ 3.0 0	- 2.5 - 4.3	4.0 8.8	+ 3.0 0	- 4.0 - 5.8	6.0 13.5	+ 4.5 0	- 6.0 - 9.0	9.0 20.5	+ 7.0 0	- 9.0 - 13.5	1.97	- 3.15
3.0 6.6	+ 2.2 - 0	- 3.0 - 4.4	3.0 8.7	+ 3.5 0	- 3.0 - 5.2	5.0 10.7	+ 3.5 0	- 5.0 - 7.2	7.0 15.5	+ 5.0 0	- 7.0 - 10.5	10.0 24.0	+ 9.0 0	- 10.0 - 15.0	3.15	- 4.73
3.5 7.6	+ 2.5 - 0	- 3.5 - 5.1	3.5 10.0	+ 4.0 0	- 3.5 - 6.0	6.0 12.5	+ 4.0 0	- 6.0 - 8.5	8.0 18.0	+ 6.0 0	- 8.0 - 12.0	12.0 28.0	+ 10.0 0	- 12.0 - 18.0	4.73	- 7.09
4.0 8.6	+ 2.8 - 0	- 4.0 - 5.8	4.0 11.3	+ 4.5 0	- 4.0 - 6.8	7.0 14.3	+ 4.5 0	- 7.0 - 9.8	10.0 21.5	+ 7.0 0	- 10.0 - 14.5	15.0 34.0	+ 12.0 0	- 15.0 - 22.0	7.09	- 9.85
5.0 10.0	+ 3.0 0	- 5.0 - 7.0	5.0 13.0	+ 5.0 0	- 5.0 - 8.0	8.0 16.0	+ 5.0 0	- 8.0 - 11.0	12.0 25.0	+ 8.0 0	- 12.0 - 17.0	18.0 38.0	+ 12.0 0	- 18.0 - 26.0	9.85	- 12.41
6.0 11.7	+ 3.5 0	- 6.0 - 8.2	6.0 15.5	+ 6.0 0	- 6.0 - 9.5	10.0 19.5	+ 6.0 0	- 10.0 - 13.5	14.0 29.0	+ 9.0 0	- 14.0 - 20.0	22.0 45.0	+ 14.0 0	- 22.0 - 31.0	12.41	- 15.75
8.0 14.5	+ 4.0 - 10.5	- 8.0 - 10.5	8.0 18.0	+ 6.0 0	- 8.0 - 12.0	12.0 22.0	+ 6.0 0	- 12.0 - 16.0	16.0 32.0	+ 10.0 0	- 16.0 - 22.0	25.0 51.0	+ 16.0 0	- 25.0 - 35.0	15.75	- 19.69
10.0 18.0	+ 5.0 0	- 10.0 - 13.0	10.0 23.0	+ 8.0 0	- 10.0 - 15.0	16.0 29.0	+ 8.0 0	- 16.0 - 21.0	20.0 40.0	+ 12.0 0	- 20.0 - 28.0	30.0 62.0	+ 20.0 0	- 30.0 - 42.0	19.69	- 30.09
12.0 22.0	+ 6.0 0	- 12.0 - 16.0	12.0 28.0	+ 10.0 0	- 12.0 - 18.0	20.0 36.0	+ 10.0 0	- 20.0 - 26.0	25.0 51.0	+ 16.0 0	- 25.0 - 35.0	40.0 81.0	+ 25.0 0	- 40.0 - 56.0	30.09	- 41.49
16.0 29.0	+ 8.0 0	- 16.0 - 21.0	16.0 36.0	+ 12.0 0	- 16.0 - 24.0	25.0 45.0	+ 12.0 0	- 25.0 - 33.0	30.0 62.0	+ 20.0 0	- 30.0 - 42.0	50.0 100	+ 30.0 0	- 50.0 - 70.0	41.49	- 56.19
20.0 36.0	+ 10.0 0	- 20.0 - 26.0	20.0 46.0	+ 16.0 0	- 20.0 - 30.0	30.0 56.0	+ 16.0 0	- 30.0 - 40.0	40.0 81.0	+ 25.0 0	- 40.0 - 56.0	60.0 125	+ 40.0 0	- 60.0 - 85.0	56.19	- 76.39
25.0 45.0	+ 12.0 0	- 25.0 - 33.0	25.0 57.0	+ 20.0 0	- 25.0 - 37.0	40.0 72.0	+ 20.0 0	- 40.0 - 52.0	50.0 100	+ 30.0 0	- 50.0 - 70.0	80.0 160	+ 50.0 0	- 80.0 - 110	76.39	- 100.9
30.0 56.0	+ 16.0 0	- 30.0 - 40.0	30.0 71.0	+ 25.0 0	- 30.0 - 46.0	50.0 91.0	+ 25.0 0	- 50.0 - 66.0	60.0 125	+ 40.0 0	- 60.0 - 85.0	100 200	+ 60.0 0	- 100 - 140	100.9	- 131.9
35.0 67.0	+ 20.0 0	- 35.0 - 47.0	35.0 85.0	+ 30.0 0	- 35.0 - 55.0	60.0 110.0	+ 30.0 0	- 60.0 - 80.0	80.0 160	+ 50.0 0	- 80.0 - 110	130 260	+ 80.0 0	- 130 - 180	131.9	- 171.9
45.0 86.0	+ 25.0 0	- 45.0 - 61.0	45.0 110.0	+ 40.0 0	- 45.0 - 70.0	80.0 145.0	+ 40.0 0	- 80.0 - 105.0	100 200	+ 60.0 0	- 100 - 140	150 310	+ 100 0	- 150 - 210	171.9	- 200

Reprinted from The American Society of Mechanical Engineers—ANSI B4.1-1967 (R1987.)



**TABLE 6 (CONTINUED)—AMERICAN NATIONAL STANDARD FITS  
CLEARANCE LOCALATIONAL FITS (LIMITS ARE IN THOUSANDTHS OF AN INCH)**

Nominal Size Range, Inches	Class LC 1				Class LC 2				Class LC 3				Class LC 4				Class LC 5		
	Clearance		Standard Tolerance Limits		Clearance		Standard Tolerance Limits		Clearance		Standard Tolerance Limits		Clearance		Standard Tolerance Limits		Clearance		
	Hole H6	Shaft h5	Hole H7	Shaft h6	Hole H8	Shaft h7	Hole H10	Shaft h9	Hole H7	Shaft h6	Hole H8	Shaft h7	Hole H10	Shaft h9	Hole H7	Shaft h6	Hole H7	Shaft g6	
Over	To	Values shown below are in thousandths of an inch																	
0–	0.12	+0.25	0	+0.4	0	+0.6	0	0	0	+0.6	0	+1.6	0	0	+0.4	0	0.1	+0.4	-0.1
		0	-0.2	0	-0.25	0	-0.4	1	-0.4	0	-0.4	0	2.6	-1.0	0	0.75	0	0	-0.35
0.12–	0.24	+0.3	0	+0.5	0	+0.7	0	0	0	+0.7	0	+1.8	0	0	+0.5	0	0.15	+0.5	-0.15
		0	-0.2	0	-0.3	0	-0.5	1.2	-0.5	0	-0.5	0	3.0	-1.2	0	0.95	0	0	-0.45
0.24–	0.40	+0.4	0	+0.6	0	+0.9	0	0	0	+0.9	0	+2.2	0	0	+0.6	0	0.2	+0.6	-0.2
		0	-0.25	0	-0.4	0	-0.6	1.5	-0.6	0	-0.6	0	3.6	-1.4	0	1.2	0	0	-0.6
0.40–	0.71	+0.4	0	+0.7	0	+1.0	0	0	0	+1.0	0	+2.8	0	0	+0.7	0	0.25	+0.7	-0.25
		0	-0.3	0	-0.4	0	-0.7	1.7	-0.7	0	-0.7	0	4.4	-1.6	0	1.35	0	0	-0.65
0.71–	1.19	+0.5	0	+0.8	0	+1.2	0	0	0	+1.2	0	+3.5	0	0	+0.8	0	0.3	+0.8	-0.3
		0	-0.4	0	-0.5	0	-0.8	2	-0.8	0	-0.8	0	5.5	-2.0	0	1.6	0	0	-0.8
1.19–	1.97	+0.6	0	+1.0	0	+1.6	0	0	0	+1.6	0	+4.0	0	0	+1.0	0	0.4	+1.0	-0.4
		0	-0.4	0	-0.6	0	-1	2.6	-1	0	-1	0	6.5	-2.5	0	2.0	0	0	-1.0
1.97–	3.15	+0.7	0	+1.2	0	+1.8	0	0	0	+1.8	0	+4.5	0	0	+1.2	0	0.4	+1.2	-0.4
		0	-0.5	0	-0.7	0	-1.2	3	-1.2	0	-1.2	0	7.5	-3	0	2.3	0	0	-1.1
3.15–	4.73	+0.9	0	+1.4	0	+2.2	0	0	0	+2.2	0	+5.0	0	0	+1.4	0	0.5	+1.4	-0.5
		0	-0.6	0	-0.9	0	-1.4	3.6	-1.4	0	-1.4	0	8.5	-3.5	0	2.8	0	0	-1.4
4.73–	7.09	+1.0	0	+1.6	0	+2.5	0	0	0	+2.5	0	+6.0	0	0	+1.6	0	0.6	+1.6	-0.6
		0	-0.7	0	-1.0	0	-1.6	4.1	-1.6	0	-1.6	0	10.0	-4	0	3.2	0	0	-1.6
7.09–	9.85	+1.2	0	+1.8	0	+2.8	0	0	0	+2.8	0	+7.0	0	0	+1.8	0	0.6	+1.8	-0.6
		0	-0.8	0	-1.2	0	-1.8	4.6	-1.8	0	-1.8	0	11.5	-4.5	0	3.6	0	0	-1.8
9.85–	12.41	+1.2	0	+2.0	0	+3.0	0	0	0	+3.0	0	+8.0	0	0	+2.0	0	0.7	+2.0	-0.7
		0	-0.9	0	-1.2	0	-2.0	5	-2.0	0	-2.0	0	13.0	-5	0	3.9	0	0	-1.9
12.41–	15.75	+1.4	0	+2.2	0	+3.5	0	0	0	+3.5	0	+9.0	0	0	+2.2	0	0.7	+2.2	-0.7
		0	-1.0	0	-1.4	0	-2.2	5.7	-2.2	0	-2.2	0	15.0	-6	0	4.3	0	0	-2.1
15.75–	19.69	+1.6	0	+2.5	0	+4	0	0	0	+4	0	+10.0	0	0	+2.5	0	0.8	+2.5	-0.8
		0	-1.0	0	-1.6	0	-2.5	6.5	-2.5	0	-2.5	0	16.0	-6	0	4.9	0	0	-2.4

**TABLE 6 (CONTINUED)—AMERICAN NATIONAL STANDARD FITS  
CLEARANCE LOCATIONAL FITS (LIMITS ARE IN THOUSANDTHS OF AN INCH)**

Nominal Size Range, Inches	Class LC 6				Class LC 7				Class LC 8				Class LC 9				Class LC 10				Class LC 11			
	Clearance		Standard Tolerance Limits		Clearance		Standard Tolerance Limits		Clearance		Standard Tolerance Limits		Clearance		Standard Tolerance Limits		Clearance		Standard Tolerance Limits		Clearance		Standard Tolerance Limits	
	Hole H9	Shaft f8	Hole H10	Shaft e9	Hole H10	Shaft e9	Hole H10	Shaft d9	Hole H11	Shaft c10	Hole H11	Shaft c10	Hole H12	Shaft	Hole H12	Shaft	Hole H13	Shaft						
Over	To	Values shown below are in thousandths of an inch																						
0–	0.12	0.3	+1.0	+1.0	0.6	+1.6	-0.6	-1.6	1.0	+1.6	-1.0	-2.0	2.5	+2.5	-2.5	-4.1	4	+4	-4	5	+6	-5	-11	
		1.9	0	3.2	0	2.0	-1.6	2.0	6.6	0	-2.0	-4.1	12	0	-4.1	12	12	0	-8	17	0	-11		
0.12–	0.24	0.4	+1.2	+1.8	0.8	+1.8	-0.8	-2.0	1.2	+1.8	-1.2	-2.4	2.8	+3.0	-2.8	-4.6	4.5	+5	-4.5	6	+7	-6	-13	
		2.3	0	3.8	0	4.2	-2.0	4.2	7.6	0	-2.4	-4.6	14.5	0	-4.6	14.5	20	0	-9.5	20	0	-13		
0.24–	0.40	0.5	+1.4	+2.2	1.0	+2.2	-1.0	-2.4	1.6	+2.2	-1.6	-3.0	3.0	+3.5	-3.0	-5.2	5	+6	-5	7	+9	-7	-16	
		2.8	0	4.6	0	5.2	-2.4	5.2	8.7	0	-3.0	-5.2	17	0	-5.2	17	17	0	-11	25	0	-16		
0.40–	0.71	0.6	+1.6	+2.8	1.2	+2.8	-1.2	-2.8	2.0	+2.8	-2.0	-3.6	3.5	+4.0	-3.5	-6.3	6	+7	-6	8	+10	-8	-18	
		3.2	0	5.6	0	6.4	-2.8	6.4	10.3	0	-3.6	-6.3	20	0	-6.3	20	20	0	-13	28	0	-18		
0.71–	1.19	0.8	+2.0	+3.5	1.6	+3.5	-1.6	-3.6	2.5	+3.5	-2.5	-4.5	4.5	+5.0	-4.5	-8.0	7	+8	-7	10	+12	-10	-22	
		4.0	0	7.1	0	8.0	-3.6	8.0	13.0	0	-4.5	-8.0	23	0	-8.0	23	23	0	-15	34	0	-22		
1.19–	1.97	1.0	+2.5	+4.0	2.0	+4.0	-2.0	-4.5	3.6	+4.0	-3.0	-5.5	5.0	+6	-5.0	-9.0	8	+10	-8	12	+16	-12	-28	
		5.1	0	8.5	0	9.5	-4.5	9.5	15.0	0	-5.5	-9.0	28	0	-9.0	28	28	0	-18	44	0	-28		
1.97–	3.15	1.2	+3.0	+4.5	2.5	+4.5	-2.5	-5.5	4.0	+4.5	-4.0	-7.0	6.0	+7	-6.0	-10.5	10	+12	-10	14	+18	-14	-32	
		6.0	0	10.0	0	11.5	-5.5	11.5	17.5	0	-7.0	-10.5	34	0	-10.5	34	34	0	-22	50	0	-32		
3.15–	4.73	1.4	+3.5	+5.0	3.0	+5.0	-3.0	-6.5	5.0	+5.0	-5.0	-8.5	7	+9	-7	-12	11	+14	-11	16	+22	-16	-38	
		7.1	0	11.5	0	13.5	-6.5	13.5	21	0	-8.5	-12	39	0	-12	39	39	0	-25	60	0	-38		
4.73–	7.09	1.6	+4.0	+6.0	3.5	+6.0	-3.5	-7.5	6	+6	-6	-10	8	+10	-8	-14	12	+16	-12	18	+25	-18	-43	
		8.1	0	13.5	0	16	-7.5	16	24	0	-10	-14	44	0	-14	44	44	0	-28	68	0	-43		
7.09–	9.85	2.0	+4.5	+7.0	4.0	+7.0	-4.0	-8.5	7	+7	-7	-11.5	10	+12	-10	-17	16	+18	-16	22	+28	-22	-50	
		9.3	0	15.5	0	18.5	-8.5	18.5	29	0	-11.5	-17	52	0	-17	52	52	0	-34	78	0	-50		
9.85–	12.41	2.2	+5.0	+8.0	4.5	+8.0	-4.5	-9.5	7	+8	-7	-12	12	+12	-12	-20	20	+20	-20	28	+30	-28	-58	
		10.2	0	17.5	0	20	-9.5	20	32	0	-12	-20	60	0	-20	60	60	0	-40	88	0	-58		
12.41–	15.75	2.5	+6.0	+9.0	5.0	+9.0	-5	-11	8	+9	-8	-14	14	+14	-14	-23	22	+22	-22	30	+35	-30	-65	
		12.0	0	20.0	0	23	-11	23	37	0	-14	-23	66	0	-23	66	66	0	-44	100	0	-65		
15.75–	19.69	2.8	+6.0	+10.0	5.0	+10.0	-5	-11	9	+10	-9	-15	16	+16	-16	-26	25	+25	-25	35	+40	-35	-75	
		12.8	0	21.0	0	25	-11	25	42	0	-15	-26	75	0	-26	75	75	0	-50	115	0	-75		



## APPENDIX I (Continued)

TABLE 6 (CONTINUED)—AMERICAN NATIONAL STANDARD FITS INTERFERENCE LOCATIONAL FITS (LIMITS ARE IN THOUSANDTHS OF AN INCH)										
Nominal Size Range, Inches	Class LN 1			Class LN 2			Class LN 3			
	Limits of Interference	Standard Limits		Limits of Interference	Standard Limits		Limits of Interference	Standard Limits		
		Hole H6	Shaft n5		Hole H7	Shaft p6		Hole H7	Shaft t6	
	Over	To	Values shown below are in thousandths of an inch							
0–	0.12	0 0.45	+0.25 0	+0.45 +0.25	0 0.65	+0.4 0	+0.65 +0.4	0.1 0.75	+0.4 0	+0.75 +0.5
0.12–	0.24	0 0.5	+0.3 0	+0.5 +0.3	0 0.8	+0.5 0	+0.8 +0.5	0.1 0.9	+0.5 0	+0.9 +0.6
0.24–	0.40	0 0.65	+0.4 0	+0.65 +0.4	0 1.0	+0.6 0	+1.0 +0.6	0.2 1.2	+0.6 0	+1.2 +0.8
0.40–	0.71	0 0.8	+0.4 0	+0.8 +0.4	0 1.1	+0.7 0	+1.1 +0.7	0.3 1.4	+0.7 0	+1.4 +1.0
0.71–	1.19	0 1.0	+0.5 0	+1.0 +0.5	0 1.3	+0.8 0	+1.3 +0.8	0.4 1.7	+0.8 0	+1.7 +1.2
1.19–	1.97	0 1.1	+0.6 0	+1.1 +0.6	0 1.6	+1.0 0	+1.6 +1.0	0.4 2.0	+1.0 0	+2.0 +1.4
1.97–	3.15	0.1 1.3	+0.7 0	+1.3 +0.8	0.2 2.1	+1.2 0	+2.1 +1.4	0.4 2.3	+1.2 0	+2.3 +1.6
3.15–	4.73	0.1 1.6	+0.9 0	+1.6 +1.0	0.2 2.5	+1.4 0	+2.5 +1.6	0.6 2.9	+1.4 0	+2.9 +2.0
4.73–	7.09	0.2 1.9	+1.0 0	+1.9 +1.2	0.2 2.8	+1.6 0	+2.8 +1.8	0.9 3.5	+1.6 0	+3.5 +2.5
7.09–	9.85	0.2 2.2	+1.2 0	+2.2 +1.4	0.2 3.2	+1.8 0	+3.2 +2.0	1.2 4.2	+1.8 0	+4.2 +3.0
9.85–	12.41	0.2 2.3	+1.2 0	+2.3 +1.4	0.2 3.4	+2.0 0	+3.4 +2.2	1.5 4.7	+2.0 0	+4.7 +3.5
12.41–	15.75	0.2 2.6	+1.4 0	+2.6 +1.6	0.3 3.9	+2.2 0	+3.9 +2.5	2.3 5.9	+2.2 0	+5.9 +4.5
15.75–	19.69	0.2 2.8	+1.6 0	+2.8 +1.8	0.3 4.4	+2.5 0	+4.4 +2.8	2.5 6.6	+2.5 0	+6.6 +5.0

TABLE 6 (CONTINUED)—AMERICAN NATIONAL STANDARD FIT FORCE AND SHRINK FITS (LIMITS ARE IN THOUSANDTHS OF AN INCH)

Nominal Size Range, Inches	Class FN 1			Class FN 2			Class FN 3			Class FN 4			Class FN 5			
	Interference	Standard Tolerance Limits		Interference	Standard Tolerance Limits		Interference	Standard Tolerance Limits		Interference	Standard Tolerance Limits		Interference	Standard Tolerance Limits		
		Hole H6	Shaft		Hole H7	Shaft s6		Hole H7	Shaft t6		Hole H7	Shaft u6		Hole H8	Shaft x7	
Over	To	Values shown below are in thousandths of an inch														
0–	0.12	0.05	+0.25	+0.5	0.2	+0.4	+0.85				0.3	+0.4	+0.95	0.3	+0.6	+1.3
		0.5	0	+0.3	0.85	0	+0.6				0.95	0	+0.7	1.3	0	+0.9
0.12–	0.24	0.1	+0.3	+0.6	0.2	+0.5	+1.0				0.4	+0.5	+1.2	0.5	+0.7	+1.7
		0.6	0	+0.4	1.0	0	+0.7				1.2	0	+0.9	1.7	0	+1.2
0.24–	0.40	0.1	+0.4	+0.75	0.4	+0.6	+1.4				0.6	+0.6	+1.6	0.5	+0.9	+2.0
		0.75	0	+0.5	1.4	0	+1.0				1.6	0	+4.2	2.0	0	+1.4
0.40–	0.56	0.1	+0.4	+0.8	0.5	+0.7	+1.6				0.7	+0.7	+1.8	0.6	+1.0	+2.3
		0.8	0	+0.5	1.6	0	+1.2				1.8	0	+1.4	2.3	0	+1.6
0.56–	0.71	0.2	+0.4	+0.9	0.5	+0.7	+1.6				0.7	+0.7	+1.8	0.8	+1.0	+2.5
		0.9	0	+0.6	1.6	0	+1.2				1.8	0	+1.4	2.5	0	+1.8
0.71–	0.95	0.2	+0.5	+1.1	0.6	+0.8	1.9				0.8	+0.8	+2.1	1.0	+1.2	+3.0
		1.1	0	+0.7	1.9	0	+1.4				2.1	0	+1.6	3.0	0	+2.2
0.95–	1.19	0.3	+0.5	+1.2	0.6	+0.8	+1.9				1.0	+0.8	+2.3	1.3	+1.2	+3.3
		1.2	0	+0.8	1.9	0	+1.4				2.3	0	+1.8	3.3	0	+2.5
1.19–	1.58	0.3	+0.6	+1.3	0.8	+1.0	+2.4				1.5	+1.0	+3.1	1.4	+1.6	+4.0
		1.3	0	+0.9	2.4	0	+1.8				3.1	0	+2.5	4.0	0	+3.0
1.58–	1.97	0.4	+0.6	+1.4	0.8	+1.0	+2.4				1.8	+1.0	+3.4	2.4	+1.6	+5.0
		1.4	0	+1.0	2.4	0	+1.8				3.4	0	+2.8	5.0	0	+4.0
1.97–	2.56	0.6	+0.7	+1.8	0.8	+1.2	+2.7				2.3	+1.2	+4.2	3.2	+1.8	+6.2
		1.8	0	+1.3	2.7	0	+2.0				4.2	0	+3.5	6.2	0	+5.0
2.56–	3.15	0.7	+0.7	+1.9	1.0	+1.2	+2.9				2.8	+1.2	+4.7	4.2	+1.8	+7.2
		1.9	0	+1.4	2.9	0	+2.2				4.7	0	+4.0	7.2	0	+6.0
3.15–	3.94	0.9	+0.9	+2.4	1.4	+1.4	+3.7				3.6	+1.4	+5.9	4.8	+2.2	+8.4
		2.4	0	+1.8	3.7	0	+2.8				5.9	0	+5.0	8.4	0	+7.0
3.94–	4.73	1.1	+0.9	+2.6	1.6	+1.4	+3.9				4.6	+1.4	+6.9	5.8	+2.2	+9.4
		2.6	0	+2.0	3.9	0	+3.0				6.9	0	+6.0	9.4	0	+8.0

TABLE 6 (CONTINUED)—AMERICAN NATIONAL STANDARD FIT FORCE AND SHRINK FITS (LIMITS ARE IN THOUSANDTHS OF AN INCH)																			
Class FN 1				Class FN 2				Class FN 3				Class FN 4				Class FN 5			
Nominal Size Range, Inches		Interference		Standard Tolerance Limits		Interference		Standard Tolerance Limits		Interference		Standard Tolerance Limits		Interference		Standard Tolerance Limits		Interference	
		Hole H6	Shaft s6	Hole H7	Shaft s6			Hole H7	Shaft t6			Hole H7	Shaft u6			Hole H8	Shaft x7		
Over	To	Values shown below are in thousandths of an inch																	
4.73–	5.52	1.2	+1.0	+2.9	1.9	+1.6	+4.5	3.4	+1.6	+6.0	5.4	+1.6	+8.0	7.5	+2.5	+11.6	+2.5	+11.6	+10.0
		2.9	0	+2.2	+4.5	0	+3.5	6.0	0	+5.0	8.0	0	+7.0	11.6	0	0	0	0	0
5.52–	6.30	1.5	+1.0	+3.2	2.4	+1.6	+5.0	3.4	+1.6	+6.0	5.4	+1.6	+8.0	+9.5	+2.5	+13.6	+2.5	+13.6	+12.0
		3.2	0	+2.5	5.0	0	+4.0	6.0	0	+5.0	8.0	0	+7.0	13.6	0	0	0	0	0
6.30–	7.09	1.8	+1.0	+3.5	2.9	+1.6	+5.5	4.4	+1.6	+7.0	6.4	+1.6	+9.0	9.5	+2.5	+13.6	+2.5	+13.6	+12.0
		3.5	0	+2.8	5.5	0	+4.5	7.0	0	+6.0	9.0	0	+8.0	13.6	0	0	0	0	0
7.09–	7.88	1.8	+1.2	+3.8	3.2	+1.8	+6.2	5.2	+1.8	+8.2	7.2	+1.8	+10.2	11.2	+2.8	+15.8	+2.8	+15.8	+14.0
		3.8	0	+3.0	6.2	0	+5.0	8.2	0	+7.0	10.2	0	+9.0	15.8	0	0	0	0	0
7.88–	8.86	2.3	+1.2	+4.3	3.2	+1.8	+6.2	5.2	+1.8	+8.2	8.2	+1.8	+11.2	13.2	+2.8	+17.8	+2.8	+17.8	+16.0
		4.3	0	+3.5	6.2	0	5.0	8.2	0	+7.0	11.2	0	+10.0	17.8	0	0	0	0	0
8.86–	9.85	2.3	+1.2	+4.3	4.2	+1.8	+7.2	6.2	+1.8	+9.2	10.2	+1.8	+13.2	13.2	+2.8	+17.8	+2.8	+17.8	+16.0
		4.3	0	+3.5	7.2	0	+6.0	9.2	0	+8.0	13.2	0	+12.0	17.8	0	0	0	0	0
9.85–	11.03	2.8	+1.2	+4.9	4.0	+2.0	+7.2	7.0	+2.0	+10.2	10.0	+2.0	+13.2	15.0	+3.0	+20.0	+3.0	+20.0	+18.0
		4.9	0	+4.0	7.2	0	+6.0	10.2	0	+9.0	13.2	0	+12.0	20.0	0	0	0	0	0
11.03–	12.41	2.8	+1.2	+4.9	5.0	+2.0	+8.2	7.0	+2.0	+10.2	12.0	+2.0	+15.2	17.0	+3.0	+22.0	+3.0	+22.0	+20.0
		4.9	0	+4.0	8.2	0	+7.0	10.2	0	+9.0	15.2	0	+14.0	22.0	0	0	0	0	0
12.41–	13.98	3.1	+1.4	+5.5	5.8	+2.2	+9.4	7.8	+2.2	+11.4	13.8	+2.2	+17.4	18.5	+3.5	+24.2	+3.5	+24.2	+22.0
		5.5	0	+4.5	9.4	0	+8.0	11.4	0	+10.0	17.4	0	+16.0	24.2	0	0	0	0	0
13.98–	15.75	3.6	+1.4	+6.1	5.8	+2.2	+9.4	9.8	+2.2	+13.4	15.8	+2.2	+19.4	21.5	+3.5	+27.2	+3.5	+27.2	+25.0
		6.1	0	+5.0	9.4	0	+8.0	13.4	0	+12.0	19.4	0	+18.0	27.2	0	0	0	0	0
15.75–	17.72	4.4	+1.6	+7.0	6.5	+2.5	+10.6	9.5	+2.5	+13.6	17.5	+2.5	+21.6	24.0	+4.0	+30.5	+4.0	+30.5	+28.0
		7.0	0	+6.0	10.6	0	+9.0	13.6	0	+12.0	21.6	0	+20.0	30.5	0	0	0	0	0
17.72–	19.69	4.4	+1.6	+7.0	7.5	+2.5	+11.6	11.5	+2.5	+15.6	19.5	+2.5	+23.6	26.0	+4.0	+32.5	+4.0	+32.5	+30.0
		7.0	0	+6.0	11.6	0	+10.0	15.6	0	+14.0	23.6	0	+22.0	32.5	0	0	0	0	0

TABLE 7 METRIC LIMITS AND FITS

AMERICAN NATIONAL STANDARD  
PREFERRED METRIC LIMITS AND FITS

ANSI B4.2

BASIC SIZE	PREFERRED HOLE BASIS CLEARANCE FITS						Dimensions in mm.									
	LOOSE RUNNING		FREE RUNNING		CLOSE RUNNING		SLIDING		LOCATIONAL CLEARANCE		Fit					
	Hole H11	Shaft c11	Fit	Hole H9	Shaft d9	Fit	Hole H8	Shaft f7	Fit	Hole H7	Shaft g6	Fit	Hole H7	Shaft h6	Fit	
1	MAX MIN	1•060 1•000	0•940 0•880	0•180 0•060	1•025 1•000	0•980 0•955	0•070 0•020	1•014 1•000	0•994 0•984	0•030 0•006	1•010 1•000	0•998 0•992	0•018 0•002	1•010 1•000	1•000 0•994	0•016 0•000
1•2	MAX MIN	1•260 1•200	1•140 1•080	0•180 0•060	1•225 1•200	1•180 1•155	0•070 0•020	1•214 1•200	1•194 1•184	0•030 0•006	1•210 1•200	1•198 1•192	0•018 0•002	1•210 1•200	1•200 1•194	0•016 0•000
1•6	MAX MIN	1•660 1•600	1•540 1•480	0•180 0•060	1•625 1•600	1•580 1•555	0•070 0•020	1•614 1•600	1•594 1•584	0•030 0•006	1•610 1•600	1•598 1•592	0•018 0•002	1•610 1•600	1•600 1•594	0•016 0•000
2	MAX MIN	2•060 2•000	1•940 1•880	0•180 0•060	2•025 2•000	1•980 1•955	0•070 0•020	2•014 2•000	1•994 1•984	0•030 0•006	2•010 2•000	1•998 1•992	0•018 0•002	2•010 2•000	2•000 1•994	0•016 0•000
2•5	MAX MIN	2•560 2•500	2•440 2•380	0•180 0•060	2•525 2•500	2•480 2•455	0•070 0•020	2•514 2•500	2•494 2•484	0•030 0•006	2•510 2•500	2•498 2•492	0•018 0•002	2•510 2•500	2•500 2•494	0•016 0•000
3	MAX MIN	3•060 3•000	2•940 2•880	0•180 0•060	3•025 3•000	2•980 2•955	0•070 0•020	3•014 3•000	2•994 2•984	0•030 0•006	3•010 3•000	2•998 2•992	0•018 0•002	3•010 3•000	3•000 2•994	0•016 0•000
4	MAX MIN	4•075 4•000	3•930 3•855	0•220 0•070	4•030 4•000	3•970 3•940	0•090 0•030	4•018 4•000	3•990 3•978	0•040 0•010	4•012 4•000	3•996 3•988	0•024 0•004	4•012 4•000	4•000 3•992	0•020 0•000
5	MAX MIN	5•075 5•000	4•930 4•855	0•220 0•070	5•030 5•000	4•970 4•940	0•090 0•030	5•018 5•000	4•990 4•978	0•040 0•010	5•012 5•000	4•996 4•988	0•024 0•004	5•012 5•000	5•000 4•992	0•020 0•000
6	MAX MIN	6•075 6•000	5•930 5•855	0•220 0•070	6•030 6•000	5•970 5•940	0•090 0•030	6•018 6•000	5•990 5•978	0•040 0•010	6•012 6•000	5•996 5•988	0•024 0•004	6•012 6•000	6•000 5•992	0•020 0•000
8	MAX MIN	8•090 8•000	7•920 7•830	0•260 0•080	8•036 8•000	7•960 7•924	0•112 0•040	8•022 8•000	7•987 7•972	0•050 0•013	8•015 8•000	7•995 7•986	0•029 0•005	8•015 8•000	8•000 7•991	0•024 0•000
10	MAX MIN	10•090 10•000	9•920 9•830	0•260 0•080	10•036 10•000	9•960 9•924	0•112 0•040	10•022 10•000	9•987 9•972	0•050 0•013	10•015 10•000	9•995 9•986	0•029 0•005	10•015 10•000	10•000 9•991	0•024 0•000
12	MAX MIN	12•110 12•000	11•905 11•795	0•315 0•095	12•043 12•000	11•950 11•907	0•136 0•050	12•027 12•000	11•984 11•966	0•061 0•016	12•018 12•000	11•994 11•983	0•035 0•006	12•018 12•000	12•000 11•989	0•029 0•000
16	MAX MIN	16•110 16•000	15•905 15•795	0•315 0•095	16•043 16•000	15•950 15•907	0•136 0•050	16•027 16•000	15•984 15•966	0•061 0•016	16•018 16•000	15•994 15•983	0•035 0•006	16•018 16•000	16•000 15•989	0•029 0•000
20	MAX MIN	20•130 20•000	19•890 19•760	0•370 0•110	20•052 20•000	19•935 19•883	0•169 0•065	20•033 20•000	19•980 19•959	0•074 0•020	20•021 20•000	19•993 19•980	0•041 0•007	20•021 20•000	20•000 19•987	0•034 0•000
25	MAX MIN	25•130 25•000	24•890 24•760	0•370 0•110	25•052 25•000	24•935 24•883	0•169 0•065	25•033 25•000	24•980 24•959	0•074 0•020	25•021 25•000	24•993 24•980	0•041 0•007	25•021 25•000	25•000 24•987	0•034 0•000
30	MAX MIN	30•130 30•000	29•890 29•760	0•370 0•110	30•052 30•000	29•935 29•883	0•169 0•065	30•033 30•000	29•980 29•959	0•074 0•020	30•021 30•000	29•993 29•980	0•041 0•007	30•021 30•000	30•000 29•987	0•034 0•000

TABLE 7 (CONTINUED)—METRIC LIMITS AND FITS

AMERICAN NATIONAL STANDARD  
PREFERRED METRIC LIMITS AND FITS

ANSI B4.2

BASIC SIZE	PREFERRED HOLE BASIS CLEARANCE FITS (Continued)						Dimensions in mm.								
	LOOSE RUNNING		FREE RUNNING		CLOSE RUNNING		SLIDING		LOCATIONAL CLEARANCE		Fit				
	Hole H11	Shaft c11	Fit	Hole H9	Shaft d9	Fit	Hole H8	Shaft f7	Fit	Hole H7	Shaft g6	Fit	Hole H7	Shaft h6	Fit
40	MAX MIN	39•880 39•720	0•440 0•120	40•062 40•000	39•920 39•858	0•204 0•080	40•039 40•000	39•975 39•950	0•089 0•025	40•025 40•000	39•991 39•975	0•050 0•009	40•025 40•000	40•000 39•984	0•041 0•000
50	MAX MIN	50•160 50•000	0•450 0•130	50•062 50•000	49•920 49•858	0•204 0•080	50•039 50•000	49•975 49•950	0•089 0•025	50•025 50•000	49•991 49•975	0•050 0•009	50•025 50•000	50•000 49•984	0•041 0•000
60	MAX MIN	60•190 60•000	0•520 0•140	60•074 60•000	59•900 59•826	0•248 0•100	60•046 60•000	59•970 59•940	0•106 0•030	60•030 60•000	59•990 59•971	0•059 0•010	60•030 60•000	60•000 59•981	0•049 0•000
80	MAX MIN	80•190 80•000	0•530 0•150	80•074 80•000	79•900 79•826	0•248 0•100	80•046 80•000	79•970 79•940	0•106 0•030	80•030 80•000	79•990 79•971	0•059 0•010	80•030 80•000	80•000 75•981	0•049 0•000
100	MAX MIN	100•220 100•000	0•610 0•170	100•087 100•000	99•880 99•793	0•294 0•120	100•054 100•000	99•964 99•929	0•125 0•036	100•035 100•000	99•988 99•966	0•069 0•012	100•035 100•000	100•000 99•978	0•057 0•000
120	MAX MIN	120•220 120•000	0•620 0•180	120•087 120•000	119•880 119•793	0•294 0•120	120•054 120•000	119•964 119•929	0•125 0•036	120•035 120•000	119•988 119•966	0•069 0•012	120•035 120•000	120•000 119•978	0•057 0•000
160	MAX MIN	160•250 160•000	0•710 0•210	160•100 160•000	159•855 159•755	0•345 0•145	160•063 160•000	159•957 159•917	0•146 0•043	160•040 160•000	159•986 159•961	0•079 0•014	160•040 160•000	160•000 159•975	0•065 0•000
200	MAX MIN	200•290 200•000	0•820 0•240	200•115 200•000	199•830 199•715	0•400 0•170	200•072 200•000	199•950 199•904	0•168 0•050	200•046 200•000	199•985 199•956	0•090 0•015	200•046 200•000	200•000 199•971	0•075 0•000
250	MAX MIN	250•290 250•000	0•860 0•280	250•115 250•000	249•830 249•715	0•400 0•170	250•072 250•000	249•950 249•904	0•168 0•050	250•046 250•000	249•985 249•956	0•090 0•015	250•046 250•000	250•000 249•971	0•075 0•000
300	MAX MIN	300•320 300•000	0•970 0•330	300•130 300•000	299•810 299•680	0•450 0•190	300•081 300•000	299•944 299•892	0•189 0•056	300•052 300•000	299•983 299•951	0•101 0•017	300•052 300•000	300•000 299•968	0•084 0•000
400	MAX MIN	400•360 400•000	1•120 0•400	400•140 400•000	399•790 399•650	0•490 0•210	400•089 400•000	399•938 399•881	0•208 0•062	400•057 400•000	399•982 399•946	0•111 0•018	400•057 400•000	400•000 399•964	0•093 0•000
500	MAX MIN	500•400 500•000	1•280 0•480	500•155 500•000	499•770 499•615	0•540 0•230	500•097 500•000	499•932 499•869	0•228 0•068	500•063 500•000	499•980 499•940	0•123 0•020	500•063 500•000	500•000 499•960	0•103 0•000

Reprinted from The American Society of Mechanical Engineers—ANSI B4.2-1978 (R1994).



TABLE 7 (CONTINUED)—METRIC LIMITS AND FITS

AMERICAN NATIONAL STANDARD  
PREFERRED METRIC LIMITS AND FITS

ANSI B4.2

BASIC SIZE	PREFERRED SHAFT BASIS CLEARANCE FITS				CLOSE RUNNING				SLIDING				LOCATIONAL CLEARANCE			
	Hole C11	Shaft h11	Fit	Hole D9	Shaft h9	Fit	Hole F8	Shaft h7	Fit	Hole G7	Shaft h6	Fit	Hole H7	Shaft h6	Fit	
1	MAX 1•120	1•000	0•180	1•045	1•000	0•070	1•020	1•000	0•030	1•012	1•000	0•018	1•010	1•000	0•016	
	MIN 1•060	0•940	0•060	1•020	0•975	0•020	1•006	0•990	0•006	1•002	0•994	0•002	1•000	0•994	0•000	
1•2	MAX 1•320	1•200	0•180	1•245	1•200	0•070	1•220	1•200	0•030	1•212	1•200	0•018	1•210	1•200	0•016	
	MIN 1•260	1•140	0•060	1•220	1•175	0•020	1•206	1•190	0•006	1•202	1•194	0•002	1•200	1•194	0•000	
1•6	MAX 1•720	1•600	0•180	1•645	1•600	0•070	1•620	1•600	0•030	1•612	1•600	0•018	1•610	1•600	0•016	
	MIN 1•660	1•540	0•060	1•620	1•575	0•020	1•606	1•590	0•006	1•602	1•594	0•002	1•600	1•594	0•000	
2	MAX 2•120	2•000	0•180	2•045	2•000	0•070	2•020	2•000	0•030	2•012	2•000	0•018	2•010	2•000	0•016	
	MIN 2•060	1•940	0•060	2•020	1•975	0•020	2•006	1•990	0•006	2•002	1•994	0•002	2•000	1•994	0•000	
2•5	MAX 2•620	2•500	0•180	2•545	2•500	0•070	2•520	2•500	0•030	2•512	2•500	0•018	2•510	2•500	0•016	
	MIN 2•560	2•440	0•060	2•520	2•475	0•020	2•506	2•490	0•006	2•502	2•494	0•002	2•500	2•494	0•000	
3	MAX 3•120	3•000	0•180	3•045	3•000	0•070	3•020	3•000	0•030	3•012	3•000	0•018	3•010	3•000	0•016	
	MIN 3•060	2•940	0•060	3•020	2•975	0•020	3•006	2•990	0•006	3•002	2•994	0•002	3•000	2•994	0•000	
4	MAX 4•145	4•000	0•220	4•060	4•000	0•090	4•028	4•000	0•040	4•016	4•000	0•024	4•012	4•000	0•020	
	MIN 4•070	3•925	0•070	4•030	3•970	0•030	4•010	3•988	0•010	4•004	3•992	0•004	4•000	3•992	0•000	
5	MAX 5•145	5•000	0•220	5•060	5•000	0•090	5•028	5•000	0•040	5•016	5•000	0•024	5•012	5•000	0•020	
	MIN 5•070	4•925	0•070	5•030	4•970	0•030	5•010	4•988	0•010	5•004	4•992	0•004	5•000	4•992	0•000	
6	MAX 6•145	6•000	0•220	6•060	6•000	0•090	6•028	6•000	0•040	6•016	6•000	0•024	6•012	6•000	0•020	
	MIN 6•070	5•925	0•070	6•030	5•970	0•030	6•010	4•988	0•010	6•004	5•992	0•004	6•000	5•992	0•000	
8	MAX 8•170	8•000	0•260	8•076	8•000	0•112	8•035	8•000	0•050	8•020	8•000	0•029	8•015	8•000	0•024	
	MIN 8•080	7•910	0•080	8•040	7•964	0•040	8•013	7•985	0•013	8•005	7•991	0•005	8•000	7•991	0•000	
10	MAX 10•170	10•000	0•260	10•076	10•000	0•112	10•035	10•000	0•050	10•020	10•000	0•029	10•015	10•000	0•024	
	MIN 10•080	9•910	0•080	10•040	9•964	0•040	10•013	9•985	0•013	10•005	9•991	0•005	10•000	9•991	0•000	
12	MAX 12•205	12•000	0•315	12•093	12•000	0•136	12•043	12•000	0•061	12•024	12•000	0•035	12•018	12•000	0•029	
	MIN 12•095	11•890	0•095	12•050	11•957	0•050	12•016	11•982	0•016	12•006	11•989	0•006	12•000	11•989	0•000	
16	MAX 16•205	16•000	0•315	16•093	16•000	0•136	16•043	16•000	0•061	16•024	16•000	0•035	16•018	16•000	0•029	
	MIN 16•095	15•890	0•095	16•050	15•957	0•050	16•016	15•982	0•016	16•006	15•989	0•006	16•000	15•989	0•000	
20	MAX 20•240	20•000	0•370	20•117	20•000	0•169	20•053	20•000	0•074	20•028	20•000	0•041	20•021	20•000	0•034	
	MIN 20•110	19•870	0•110	20•065	19•948	0•065	20•020	19•979	0•020	20•007	19•987	0•007	20•000	19•987	0•000	
25	MAX 25•240	25•000	0•370	25•117	25•000	0•169	25•053	25•000	0•074	25•028	25•000	0•041	25•021	25•000	0•034	
	MIN 25•110	24•870	0•110	25•065	24•948	0•065	25•020	24•979	0•020	25•007	24•987	0•007	25•000	24•987	0•000	
30	MAX 30•240	30•000	0•370	30•117	30•000	0•169	30•053	30•000	0•074	30•028	30•000	0•041	30•021	30•000	0•034	
	MIN 30•110	29•870	0•110	30•065	29•948	0•065	30•020	29•979	0•020	30•007	29•987	0•007	30•000	29•987	0•000	

TABLE 7 (CONTINUED)—METRIC LIMITS AND FITS

AMERICAN NATIONAL STANDARD  
PREFERRED METRIC LIMITS AND FITS

ANSI B4.2

BASIC SIZE	PREFERRED SHAFT BASIS CLEARANCE FITS (Continued)										Dimensions in mm.				
	LOOSE RUNNING		FREE RUNNING		CLOSE RUNNING		SLIDING		LOCATIONAL CLEARANCE		Hole H7	Shaft h6	Fit		
	Hole C11	Shaft h11	Fit	Hole D9	Shaft h9	Fit	Hole F8	Shaft h7	Fit	Hole G7	Shaft h6	Fit	Fit		
40	MAX	40•280	40•000	0•440	40•142	40•000	0•204	40•064	40•000	0•089	40•034	40•000	0•050	40•000	0•041
	MIN	40•120	39•840	0•120	40•080	39•938	0•080	40•025	39•975	0•025	40•009	39•984	0•009	39•984	0•000
50	MAX	50•290	50•000	0•450	50•142	50•000	0•204	50•064	50•000	0•089	50•034	50•000	0•050	50•000	0•041
	MIN	50•130	49•840	0•130	50•080	49•938	0•080	50•025	49•975	0•025	50•009	49•984	0•009	49•984	0•000
60	MAX	60•330	60•000	0•520	60•174	60•000	0•248	60•076	60•000	0•106	60•040	60•000	0•059	60•000	0•049
	MIN	60•140	59•810	0•140	60•100	59•926	0•100	60•030	59•970	0•030	60•010	59•981	0•010	59•981	0•000
80	MAX	80•340	80•000	0•530	80•174	80•000	0•248	80•076	80•000	0•106	80•040	80•000	0•059	80•000	0•049
	MIN	80•150	79•810	0•150	80•100	79•926	0•100	80•030	79•970	0•030	80•010	79•981	0•010	79•981	0•000
100	MAX	100•390	100•000	0•610	100•207	100•000	0•294	100•090	100•000	0•125	100•047	100•000	0•069	100•000	0•057
	MIN	100•170	99•780	0•170	100•120	99•913	0•120	100•036	99•965	0•036	100•012	99•978	0•012	99•978	0•000
120	MAX	120•400	120•000	0•620	120•207	120•000	0•294	120•090	120•000	0•125	120•047	120•000	0•069	120•000	0•057
	MIN	120•180	119•780	0•180	120•120	119•913	0•120	120•036	119•965	0•036	120•012	119•978	0•012	119•978	0•000
160	MAX	160•460	160•000	0•710	160•245	160•000	0•345	160•106	160•000	0•146	160•054	160•000	0•079	160•000	0•065
	MIN	160•210	159•750	0•210	160•145	159•900	0•145	160•043	159•960	0•043	160•014	159•975	0•014	159•975	0•000
200	MAX	200•530	200•000	0•820	200•285	200•000	0•400	200•122	200•000	0•168	200•061	200•000	0•090	200•000	0•075
	MIN	200•240	199•710	0•240	200•170	199•885	0•170	200•050	199•954	0•050	200•015	199•971	0•015	199•971	0•000
250	MAX	250•570	250•000	0•860	250•285	250•000	0•400	250•122	250•000	0•168	250•061	250•000	0•090	250•000	0•075
	MIN	250•280	249•710	0•280	250•170	249•885	0•170	250•050	249•954	0•050	250•015	249•971	0•015	249•971	0•000
300	MAX	300•650	300•000	0•970	300•320	300•000	0•450	300•137	300•000	0•189	300•069	300•000	0•101	300•000	0•084
	MIN	300•330	299•680	0•330	300•190	299•870	0•190	300•056	299•948	0•056	300•017	299•968	0•017	299•968	0•000
400	MAX	400•760	400•000	1•120	400•350	400•000	0•490	400•151	400•000	0•208	400•075	400•000	0•111	400•000	0•093
	MIN	400•400	399•640	0•400	400•210	399•860	0•210	400•062	399•943	0•062	400•018	399•964	0•018	399•964	0•000
500	MAX	500•880	500•000	1•280	500•385	500•000	0•540	500•165	500•000	0•228	500•083	500•000	0•123	500•000	0•103
	MIN	500•480	499•600	0•480	500•230	499•845	0•230	500•068	499•937	0•068	500•020	499•960	0•020	499•960	0•000

Reprinted from The American Society of Mechanical Engineers—ANSI B4.2-1978 (R1994).

APPENDIX I (Continued)

TABLE 8 METRIC TOLERANCE ZONES

Metric Tolerance Zones for Internal (Hole) Dimensions (A14 through A9 and B14 through B9)

Dimensions in mm.

BASIC SIZE	A14	A13	A12	A11	A10	A9	B14	B13	B12	B11	B10	B9
OVER TO 0 3	+0.520 +0.270	+0.410 +0.270	+0.370 +0.270	+0.330 +0.270	+0.310 +0.270	+0.295 +0.270	+0.390 +0.140	+0.280 +0.140	+0.240 +0.140	+0.200 +0.140	+0.180 +0.140	+0.165 +0.140
OVER TO 3 6	+0.570 +0.270	+0.450 +0.270	+0.390 +0.270	+0.345 +0.270	+0.318 +0.270	+0.300 +0.270	+0.440 +0.140	+0.320 +0.140	+0.260 +0.140	+0.215 +0.140	+0.188 +0.140	+0.170 +0.140
OVER TO 6 10	+0.640 +0.280	+0.500 +0.280	+0.430 +0.280	+0.370 +0.280	+0.338 +0.280	+0.316 +0.280	+0.510 +0.150	+0.370 +0.150	+0.300 +0.150	+0.240 +0.150	+0.208 +0.150	+0.186 +0.150
OVER TO 10 14	+0.720 +0.290	+0.560 +0.290	+0.470 +0.290	+0.400 +0.290	+0.360 +0.290	+0.333 +0.290	+0.580 +0.150	+0.420 +0.150	+0.330 +0.150	+0.260 +0.150	+0.220 +0.150	+0.193 +0.150
OVER TO 14 18	+0.720 +0.290	+0.560 +0.290	+0.470 +0.290	+0.400 +0.290	+0.360 +0.290	+0.333 +0.290	+0.580 +0.150	+0.420 +0.150	+0.330 +0.150	+0.260 +0.150	+0.220 +0.150	+0.193 +0.150
OVER TO 18 24	+0.820 +0.300	+0.630 +0.300	+0.510 +0.300	+0.430 +0.300	+0.384 +0.300	+0.352 +0.300	+0.680 +0.160	+0.490 +0.160	+0.370 +0.160	+0.290 +0.160	+0.244 +0.160	+0.212 +0.160
OVER TO 24 30	+0.820 +0.300	+0.630 +0.300	+0.510 +0.300	+0.430 +0.300	+0.384 +0.300	+0.352 +0.300	+0.680 +0.160	+0.490 +0.160	+0.370 +0.160	+0.290 +0.160	+0.244 +0.160	+0.212 +0.160
OVER TO 30 40	+0.930 +0.310	+0.700 +0.310	+0.560 +0.310	+0.470 +0.310	+0.410 +0.310	+0.372 +0.310	+0.790 +0.170	+0.560 +0.170	+0.420 +0.170	+0.330 +0.170	+0.270 +0.170	+0.232 +0.170
OVER TO 40 50	+0.940 +0.320	+0.710 +0.320	+0.570 +0.320	+0.480 +0.320	+0.420 +0.320	+0.382 +0.320	+0.800 +0.180	+0.570 +0.180	+0.430 +0.180	+0.340 +0.180	+0.280 +0.180	+0.242 +0.180
OVER TO 50 65	+1.080 +0.340	+0.800 +0.340	+0.640 +0.340	+0.530 +0.340	+0.460 +0.340	+0.414 +0.340	+0.930 +0.190	+0.650 +0.190	+0.490 +0.190	+0.380 +0.190	+0.310 +0.190	+0.264 +0.190
OVER TO 65 80	+1.100 +0.360	+0.820 +0.360	+0.660 +0.360	+0.550 +0.360	+0.480 +0.360	+0.434 +0.360	+0.940 +0.200	+0.660 +0.200	+0.500 +0.200	+0.390 +0.200	+0.320 +0.200	+0.274 +0.200
OVER TO 80 100	+1.250 +0.380	+0.920 +0.380	+0.730 +0.380	+0.600 +0.380	+0.520 +0.380	+0.467 +0.380	+1.090 +0.220	+0.760 +0.220	+0.570 +0.220	+0.440 +0.220	+0.360 +0.220	+0.307 +0.220
OVER TO 100 120	+1.280 +0.410	+0.950 +0.410	+0.760 +0.410	+0.630 +0.410	+0.550 +0.410	+0.497 +0.410	+1.110 +0.240	+0.780 +0.240	+0.590 +0.240	+0.460 +0.240	+0.380 +0.240	+0.327 +0.240
OVER TO 120 140	+1.460 +0.460	+1.090 +0.460	+0.860 +0.460	+0.710 +0.460	+0.620 +0.460	+0.560 +0.460	+1.260 +0.260	+0.890 +0.260	+0.660 +0.260	+0.510 +0.260	+0.420 +0.260	+0.360 +0.260
OVER TO 140 160	+1.520 +0.520	+1.150 +0.520	+0.920 +0.520	+0.770 +0.520	+0.680 +0.520	+0.620 +0.520	+1.280 +0.280	+0.910 +0.280	+0.680 +0.280	+0.530 +0.280	+0.440 +0.280	+0.380 +0.280
OVER TO 160 180	+1.580 +0.580	+1.210 +0.580	+0.980 +0.580	+0.830 +0.580	+0.740 +0.580	+0.680 +0.580	+1.310 +0.310	+0.940 +0.310	+0.710 +0.310	+0.560 +0.310	+0.470 +0.310	+0.410 +0.310
OVER TO 180 200	+1.810 +0.660	+1.380 +0.660	+1.120 +0.660	+0.950 +0.660	+0.845 +0.660	+0.775 +0.660	+1.490 +0.340	+1.060 +0.340	+0.800 +0.340	+0.630 +0.340	+0.525 +0.340	+0.455 +0.340
OVER TO 200 225	+1.890 +0.740	+1.460 +0.740	+1.200 +0.740	+1.030 +0.740	+0.925 +0.740	+0.855 +0.740	+1.530 +0.380	+1.100 +0.380	+0.840 +0.380	+0.670 +0.380	+0.565 +0.380	+0.495 +0.380
OVER TO 225 250	+1.970 +0.820	+1.540 +0.820	+1.280 +0.820	+1.110 +0.820	+1.005 +0.820	+0.935 +0.820	+1.570 +0.420	+1.140 +0.420	+0.880 +0.420	+0.710 +0.420	+0.605 +0.420	+0.535 +0.420
OVER TO 250 280	+2.220 +0.920	+1.730 +0.920	+1.440 +0.920	+1.240 +0.920	+1.130 +0.920	+1.050 +0.920	+1.780 +0.480	+1.290 +0.480	+1.000 +0.480	+0.800 +0.480	+0.690 +0.480	+0.610 +0.480
OVER TO 280 315	+2.350 +1.050	+1.860 +1.050	+1.570 +1.050	+1.370 +1.050	+1.260 +1.050	+1.180 +1.050	+1.840 +0.540	+1.350 +0.540	+1.060 +0.540	+0.860 +0.540	+0.750 +0.540	+0.670 +0.540
OVER TO 315 355	+2.600 +1.200	+2.090 +1.200	+1.770 +1.200	+1.560 +1.200	+1.430 +1.200	+1.340 +1.200	+2.000 +0.600	+1.490 +0.600	+1.170 +0.600	+0.960 +0.600	+0.830 +0.600	+0.740 +0.600
OVER TO 355 400	+2.750 +1.350	+2.240 +1.350	+1.920 +1.350	+1.710 +1.350	+1.580 +1.350	+1.490 +1.350	+2.080 +0.680	+1.570 +0.680	+1.250 +0.680	+1.040 +0.680	+0.910 +0.680	+0.820 +0.680
OVER TO 400 450	+3.050 +1.500	+2.470 +1.500	+2.130 +1.500	+1.900 +1.500	+1.750 +1.500	+1.655 +1.500	+2.310 +0.760	+1.730 +0.760	+1.390 +0.760	+1.160 +0.760	+1.010 +0.760	+0.915 +0.760
OVER TO 450 500	+3.200 +1.650	+2.620 +1.650	+2.280 +1.650	+2.050 +1.650	+1.900 +1.650	+1.805 +1.650	+2.390 +0.840	+1.810 +0.840	+1.470 +0.840	+1.240 +0.840	+1.090 +0.840	+0.995 +0.840

Reprinted from The American Society of Mechanical Engineers—ANSI B4.2-1978 (R1994),

APPENDIX I (Continued)

TABLE 8 (CONTINUED)—METRIC TOLERANCE ZONES

Tolerance Zones for External (Shaft) Dimensions (a14 through a9 and b14 through b9)

Dimensions in mm.

BASIC SIZE	a14	a13	a12	a11	a10	a9	b14	b13	b12	b11	b10	b9
OVER TO 0 3	-0.270 -0.520	-0.270 -0.410	-0.270 -0.370	-0.270 -0.330	-0.270 -0.310	-0.270 -0.295	-0.140 -0.390	-0.140 -0.280	-0.140 -0.240	-0.140 -0.200	-0.140 -0.180	-0.140 -0.165
OVER TO 3 6	-0.270 -0.570	-0.270 -0.450	-0.270 -0.390	-0.270 -0.345	-0.270 -0.318	-0.270 -0.300	-0.140 -0.440	-0.140 -0.320	-0.140 -0.260	-0.140 -0.215	-0.140 -0.188	-0.140 -0.170
OVER TO 6 10	-0.280 -0.640	-0.280 -0.500	-0.280 -0.430	-0.280 -0.370	-0.280 -0.338	-0.280 -0.316	-0.150 -0.510	-0.150 -0.370	-0.150 -0.300	-0.150 -0.240	-0.150 -0.208	-0.150 -0.186
OVER TO 10 14	-0.290 -0.720	-0.290 -0.560	-0.290 -0.470	-0.290 -0.400	-0.290 -0.360	-0.290 -0.333	-0.150 -0.580	-0.150 -0.420	-0.150 -0.330	-0.150 -0.260	-0.150 -0.220	-0.150 -0.193
OVER TO 14 18	-0.290 -0.720	-0.290 -0.560	-0.290 -0.470	-0.290 -0.400	-0.290 -0.360	-0.290 -0.333	-0.150 -0.580	-0.150 -0.420	-0.150 -0.330	-0.150 -0.260	-0.150 -0.220	-0.150 -0.193
OVER TO 18 24	-0.300 -0.820	-0.300 -0.630	-0.300 -0.510	-0.300 -0.430	-0.300 -0.384	-0.300 -0.352	-0.160 -0.680	-0.160 -0.490	-0.160 -0.370	-0.160 -0.290	-0.160 -0.244	-0.160 -0.212
OVER TO 24 30	-0.300 -0.820	-0.300 -0.630	-0.300 -0.510	-0.300 -0.430	-0.300 -0.384	-0.300 -0.352	-0.160 -0.680	-0.160 -0.490	-0.160 -0.370	-0.160 -0.290	-0.160 -0.244	-0.160 -0.212
OVER TO 30 40	-0.310 -0.930	-0.310 -0.700	-0.310 -0.560	-0.310 -0.470	-0.310 -0.410	-0.310 -0.372	-0.170 -0.790	-0.170 -0.560	-0.170 -0.420	-0.170 -0.330	-0.170 -0.270	-0.170 -0.232
OVER TO 40 50	-0.320 -0.940	-0.320 -0.710	-0.320 -0.570	-0.320 -0.480	-0.320 -0.420	-0.320 -0.382	-0.180 -0.800	-0.180 -0.570	-0.180 -0.430	-0.180 -0.340	-0.180 -0.280	-0.180 -0.242
OVER TO 50 65	-0.340 -1.080	-0.340 -0.800	-0.340 -0.640	-0.340 -0.530	-0.340 -0.460	-0.340 -0.414	-0.190 -0.930	-0.190 -0.650	-0.190 -0.490	-0.190 -0.380	-0.190 -0.310	-0.190 -0.264
OVER TO 65 80	-0.360 -1.100	-0.360 -0.820	-0.360 -0.660	-0.360 -0.550	-0.360 -0.480	-0.360 -0.434	-0.200 -0.940	-0.200 -0.660	-0.200 -0.500	-0.200 -0.390	-0.200 -0.320	-0.200 -0.274
OVER TO 80 100	-0.380 -1.250	-0.380 -0.920	-0.380 -0.730	-0.380 -0.600	-0.380 -0.520	-0.380 -0.467	-0.220 -1.090	-0.220 -0.760	-0.220 -0.570	-0.220 -0.440	-0.220 -0.360	-0.220 -0.307
OVER TO 100 120	-0.410 -1.280	-0.410 -0.950	-0.410 -0.760	-0.410 -0.630	-0.410 -0.550	-0.410 -0.497	-0.240 -1.110	-0.240 -0.780	-0.240 -0.590	-0.240 -0.460	-0.240 -0.380	-0.240 -0.327
OVER TO 120 140	-0.460 -1.460	-0.460 -1.090	-0.460 -0.860	-0.460 -0.710	-0.460 -0.620	-0.460 -0.560	-0.260 -1.260	-0.260 -0.890	-0.260 -0.660	-0.260 -0.510	-0.260 -0.420	-0.260 -0.360
OVER TO 140 160	-0.520 -1.520	-0.520 -1.150	-0.520 -0.920	-0.520 -0.770	-0.520 -0.680	-0.520 -0.620	-0.280 -1.280	-0.280 -0.910	-0.280 -0.680	-0.280 -0.530	-0.280 -0.440	-0.280 -0.380
OVER TO 160 180	-0.580 -1.580	-0.580 -1.210	-0.580 -0.980	-0.580 -0.830	-0.580 -0.740	-0.580 -0.680	-0.310 -1.310	-0.310 -0.940	-0.310 -0.710	-0.310 -0.560	-0.310 -0.470	-0.310 -0.410
OVER TO 180 200	-0.660 -1.810	-0.660 -1.380	-0.660 -1.120	-0.660 -0.950	-0.660 -0.845	-0.660 -0.775	-0.340 -1.490	-0.340 -1.060	-0.340 -0.800	-0.340 -0.630	-0.340 -0.525	-0.340 -0.455
OVER TO 200 225	-0.740 -1.890	-0.740 -1.460	-0.740 -1.200	-0.740 -1.030	-0.740 -0.925	-0.740 -0.855	-0.380 -1.530	-0.380 -1.100	-0.380 -0.840	-0.380 -0.670	-0.380 -0.565	-0.380 -0.495
OVER TO 225 250	-0.820 -1.970	-0.820 -1.540	-0.820 -1.280	-0.820 -1.110	-0.820 -1.005	-0.820 -0.935	-0.420 -1.570	-0.420 -1.140	-0.420 -0.880	-0.420 -0.710	-0.420 -0.605	-0.420 -0.535
OVER TO 250 280	-0.920 -2.220	-0.920 -1.730	-0.920 -1.440	-0.920 -1.240	-0.920 -1.130	-0.920 -1.050	-0.480 -1.780	-0.480 -1.290	-0.480 -1.000	-0.480 -0.800	-0.480 -0.690	-0.480 -0.610
OVER TO 280 315	-1.050 -2.350	-1.050 -1.860	-1.050 -1.570	-1.050 -1.370	-1.050 -1.260	-1.050 -1.180	-0.540 -1.840	-0.540 -1.350	-0.540 -1.060	-0.540 -0.860	-0.540 -0.750	-0.540 -0.670
OVER TO 315 355	-1.200 -2.600	-1.200 -2.090	-1.200 -1.770	-1.200 -1.560	-1.200 -1.430	-1.200 -1.340	-0.600 -2.000	-0.600 -1.490	-0.600 -1.170	-0.600 -0.960	-0.600 -0.830	-0.600 -0.740
OVER TO 355 400	-1.350 -2.750	-1.350 -2.240	-1.350 -1.920	-1.350 -1.710	-1.350 -1.580	-1.350 -1.490	-0.680 -2.080	-0.680 -1.570	-0.680 -1.250	-0.680 -1.040	-0.680 -0.910	-0.680 -0.820
OVER TO 400 450	-1.500 -3.050	-1.500 -2.470	-1.500 -2.130	-1.500 -1.900	-1.500 -1.750	-1.500 -1.655	-0.760 -2.310	-0.760 -1.730	-0.760 -1.390	-0.760 -1.160	-0.760 -1.010	-0.760 -0.915
OVER TO 450 500	-1.650 -3.200	-1.650 -2.620	-1.650 -2.280	-1.650 -2.050	-1.650 -1.900	-1.650 -1.805	-0.840 +2.390	-0.840 -1.810	-0.840 -1.470	-0.840 -1.240	-0.840 -1.090	-0.840 -0.995

Reprinted from The American Society of Mechanical Engineers—ANSI B4.2-1978 (R1994).

## APPENDIX J

### UNIFIED SCREW THREAD VARIATIONS

THE FOLLOWING list is a ready reference of available standard series and selected combinations of Unified screw threads. Each thread is given as part of a proper thread note including major diameter, threads per inch, and series identification.

0-80 UNF	7/16-27 UNS	7/8-28 UN	1-3/8-18 UNEF	1-15/16-6 UN	2-7/8-12 UN
1-64 UNC	7/16-28 UNEF	7/8-32 UN	1-3/8-20 UN	1-15/16-8 UN	2-7/8-16 UN
1-72 UNF	7/16-32 UN	15/16-12 UN	1-3/8-28 UN	1-15/16-12 UN	2-7/8-20 UN
2-56 UNC	1/2-12 UNS	15/16-16 UN	1-7/16-6 UN	1-15/16-16 UN	3-4 UNC
2-64 UNF	1/2-13 UNC	15/16-20 UNEF	1-7/16-8 UN	1-15/16-20 UN	3-6 UN
3-48 UNC	1/2-14 UNS	15/16-28 UN	1-7/16-12 UN	2-4 1/2 UNC	3-8 UN
3-56 UNF	1/2-16 UN	15/16-32 UN	1-7/16-16 UN	2-6 UN	3-10 UNS
4-40 UNC	1/2-18 UNS	1-8 UNC	1-7/16-18 UNEF	2-8 UN	3-12 UN
4-48 UNF	1/2-20 UNF	1-10 UNS	1-7/16-20 UN	2-10 UNS	3-14 UNS
5-40 UNC	1/2-24 UNS	1-12 UNF	1-7/16-28 UN	2-12 UN	3-16 UN
5-44 UNF	1/2-27 UNS	1-14 UNS	1-1/2-6 UNC	2-14 UNS	3-18 UNS
6-32 UNC	1/2-28 UNEF	1-16 UN	1-1/2-8 UN	2-16 UN	3-20 UN
6-40 UNF	1/2-32 UN	1-18 UNS	1-1/2-10 UNS	2-18 UNS	3-1/8-6 UN
8-32 UNC	9/16-12 UNC	1-20 UNEF	1-1/2-12 UNF	2-20 UN	3-1/8-8 UN
8-36 UNF	9/16-14 UNS	1-24 UNS	1-1/2-14 UNS	2-1/16-16 UNS	3-1/8-12 UN
10-24 UNC	9/16-16 UN	1-27 UNS	1-1/2-16 UN	2-1/8-6 UN	3-1/8-16 UN
10-28 UNS	9/16-18 UNF	1-28 UN	1-1/2-18 UNEF	2-1/8-8 UN	3-1/4-4 UNC
10-32 UNF	9/16-20 UN	1-32 UN	1-1/2-20 UN	2-1/8-12 UN	3-1/4-6 UN
10-36 UNS	9/16-24 UNEF	1-1/16-8 UN	1-1/2-24 UNS	2-1/8-16 UN	3-1/4-8 UN
10-40 UNS	9/16-27 UNS	1-1/16-12 UN	1-1/2-28 UN	2-1/8-20 UN	3-1/4-10 UNS
10-48 UNS	9/16-28 UN	1-1/16-16 UN	1-9/16-6 UN	2-3/16-16 UNS	3 1/4-12 UN
10-56 UNS	9/16-32 UN	1-1/16-18 UNEF	1-9/16-8 UN	2-1/4-4-1/2 UNC	3 1/4-14 UNS
12-24 UNC	5/8-11 UNC	1-1/16-20 UN	1-9/16-12 UN	2-1/4-6 UN	3 1/4-16 UN
12-28 UNF	5/8-12 UN	1-1/16-28 UN	1-9/16-16 UN	2-1/4-8 UN	3-1/4-18 UNS
12-32 UNEF	5/8-14 UNS	1-1/8-7 UNC	1-9/16-18 UNEF	2-1/4-10 UNS	3-3/8-6 UN
12-36 UNS	5/8-16 UN	1-1/8-8 UN	1-9/16-20 UN	2-1/4-12 UN	3-3/8-8 UN
12-40 UNS	5/8-18 UNF	1-1/8-10 UNS	1-5/8-6 UN	2-1/4-14 UNS	3-3/8-12 UN
12-48 UNS	5/8-20 UN	1-1/8-12 UNF	1-5/8-8 UN	2-1/4-16 UN	3-3/8-16 UN
12-56 UNS	5/8-24 UNEF	1-1/8-14 UNS	1-5/8-10 UNS	2-1/4-18 UNS	3-1/2-4 UNC
1/4-20 UNC	5/8-27 UNS	1-1/8-16 UN	1-5/8-12 UN	2-1/4-20 UN	3-1/2-6 UN
1/4-24 UNS	5/8-28 UN	1-1/8-18 UNEF	1-5/8-14 UNS	2-5/16-16 UNS	3-1/2-8 UN
1/4-27 UNS	5/8-32 UN	1-1/8-20 UN	1-5/8-16 UN	2-3/8-6 UN	3-1/2-10 UNS
1/4-28 UNF	11/16-12 UN	1-1/8-24 UNS	1-5/8-18 UNEF	2-3/8-8 UN	3-1/2-12 UN
1/4-32 UNEF	11/16-16 UN	1-1/8-28 UN	1-5/8-20 UN	2-3/8-12 UN	3-1/2-14 UNS
1/4-36 UNS	11/16-20 UN	1-3/16-8 UN	1-5/8-24 UNS	2-3/8-16 UN	3-1/2-16 UN
1/4-40 UNS	11/16-24 UNEF	1-3/16-12 UN	1-11/16-6 UN	2-3/8-20 UN	3-1/2-18 UNS
1/4-48 UNS	11/16-28 UN	1-3/16-16 UN	1-11/16-8 UN	2-7/16-16 UNS	3-5/8-6 UN
1/4-56 UNS	11/16-32 UN	1-3/16-18 UNEF	1-11/16-12 UN	2-1/2-4 UNC	3-5/8-8 UN
5/16-18 UNC	3/4-10 UNC	1-3/16-20 UN	1-11/16-16 UN	2-1/2-6 UN	3-5/8-12 UN
5/16-20 UN	3/4-12 UN	1-3/16-28 UN	1-11/16-18 UNEF	2-1/2-8 UN	3-5/8-16 UN
5/16-24 UNF	3/4-14 UNS	1-1/4-7 UNC	1-11/16-20 UN	2-1/2-10 UNS	3-3/4-4 UNC
5/16-27 UNS	3/4-16 UNF	1-1/4-8 UN	1-3/4-5 UNC	2-1/2-12 UN	3-3/4-6 UN
5/16-28 UN	3/4-18 UNS	1-1/4-10 UNS	1-3/4-6 UN	2-1/2-14 UNS	3-3/4-8 UN
5/16-32 UNEF	3/4-20 UNEF	1-1/4-12 UNF	1-3/4-8 UN	2-1/2-16 UN	3-3/4-10 UNS
5/16-36 UNS	3/4-24 UNS	1-1/4-14 UNS	1-3/4-10 UNS	1-1/2-18 UNS	3-3/4-12 UN
5/16-40 UNS	3/4-27 UNS	1-1/4-16 UN	1-3/4-12 UN	2-1/2-20 UN	3-3/4-14 UNS
5/16-48 UNS	3/4-28 UN	1-1/4-18 UNEF	1-3/4-14 UNS	2-5/8-6 UN	3-3/4-16 UN
3/8-16 UNC	3/4-32 UN	1-1/4-20 UN	1-3/4-16 UN	2-5/8-8 UN	3-3/4-18 UNS
3/8-18 UNS	13/16-12 UN	1-1/4-24 UNS	1-3/4-18 UNS	2-5/8-12 UN	3-7/8-6 UN
3/8-20 UN	13/16-16 UN	1-1/4-28 UN	1-3/4-20 UN	2-5/8-16 UN	3-7/8-8 UN
3/8-24 UNF	13/16-20 UNEF	1-5/16-8 UN	1-13/16-6 UN	2-5/8-20 UN	3-7/8-12 UN
3/8-27 UNS	13/16-28 UN	1-5/16-12 UN	1-13/16-8 UN	2-3/4-4 UNC	3-7/8-16 UN
3/8-28 UN	13/16-32 UN	1-5/16-16 UN	1-13/16-12 UN	2-3/4-6 UN	4-4 UNC
3/8-32 UNEF	7/8-9 UNC	1-5/16-18 UNEF	1-13/16-20 UN	2-3/4-8 UN	4-6 UN
3/8-36 UNS	7/8-10 UNS	1-5/16-20 UN	1-7/8-6 UN	2-3/4-10 UNS	4-8 UN
3/8-40 UNS	7/8-12 UN	1-5/16-28 UN	1-7/8-8 UN	2-3/4-12 UN	4-10 UNS
.390-27 UNS	7/8-14 UNF	1-3/8-6 UNC	1-7/8-10 UNS	2-3/4-14 UNS	4-12 UN
7/16-14 UNC	7/8-16 UN	1-3/8-8 UN	1-7/8-12 UN	2-3/4-16 UN	4-14 UNS
7/16-16 UN	7/8-18 UNS	1-3/8-10 UNS	1-7/8-14 UNS	2-3/4-18 UNS	4-16 UN
7/16-18 UNS	7/8-20 UNEF	1-3/8-12 UNF	1-7/8-16 UN	2-3/4-20 UN	
7/16-20 UNF	7/8-24 UNS	1-3/8-14 UNS	1-7/8-18 UNS	2-7/8-6 UN	
7/16-24 UNS	7/8-27 UNS	1-3/8-16 UN	1-7/8-20 UN	2-7/8-8 UN	

APPENDIX J (Continued)

TABLE 9 UNIFIED STANDARD SCREW THREAD SERIES

Sizes		Basic Major Diameter	THREADS PER INCH											Sizes								
Primary	Secondary		Series with graded pitches			Series with constant pitches																
			Coarse UNC	Fine UNF	Extra fine UNEF	4UN	6UN	8UN	12UN	16UN	20UN	28UN	32UN									
0		0.0600	—	80	—	—	—	—	—	—	—	—	—	—	—	0						
	1	0.0730	64	72	—	—	—	—	—	—	—	—	—	—	—	1						
2		0.0860	56	64	—	—	—	—	—	—	—	—	—	—	—	2						
	3	0.0990	48	56	—	—	—	—	—	—	—	—	—	—	—	3						
4		0.1120	40	48	—	—	—	—	—	—	—	—	—	—	—	4						
5		0.1250	40	44	—	—	—	—	—	—	—	—	—	—	—	5						
6		0.1380	32	40	—	—	—	—	—	—	—	—	—	—	—	6						
8		0.1640	32	36	—	—	—	—	—	—	—	—	—	—	—	8						
10		0.1900	24	32	—	—	—	—	—	—	—	—	—	—	—	10						
	12	0.2160	24	28	32	—	—	—	—	—	—	—	—	UNF	—	12						
1/4		0.2500	20	28	32	—	—	—	—	—	—	—	—	UNC	UNF	UNEF	1/4					
5/16		0.3125	18	24	32	—	—	—	—	—	—	—	—	20	28	UNEF	5/16					
3/8		0.3750	16	24	32	—	—	—	—	—	—	—	—	20	28	UNEF	3/8					
7/16		0.4375	14	20	28	—	—	—	—	—	—	—	—	16	UNF	UNEF	7/16					
1/2		0.5000	13	20	28	—	—	—	—	—	—	—	—	16	UNF	UNEF	1/2					
9/16		0.5625	12	18	24	—	—	—	—	—	—	—	—	16	20	28	32	9/16				
5/8		0.6250	11	18	24	—	—	—	—	—	—	—	—	12	16	20	28	32	5/8			
	1 1/16	0.6875	—	—	24	—	—	—	—	—	—	—	—	16	20	28	32	—	1 1/16			
3/4		0.7500	10	16	20	—	—	—	—	—	—	—	—	16	UNF	UNEF	28	32	3/4			
	1 3/16	0.8125	—	—	20	—	—	—	—	—	—	—	—	12	16	UNEF	28	32	1 3/16			
7/8		0.8750	9	14	20	—	—	—	—	—	—	—	—	12	16	UNEF	28	32	7/8			
	1 5/16	0.9375	—	—	20	—	—	—	—	—	—	—	—	16	UNEF	28	32	—	1 5/16			
1		1.0000	8	12	20	—	—	—	—	—	—	—	—	—	—	—	—	—	1			
	1 1/16	1.0625	—	—	18	—	—	—	—	—	—	—	—	8	12	16	20	28	—	1 1/16		
1 1/8		1.1250	7	12	18	—	—	—	—	—	—	—	—	8	UNF	16	20	28	—	1 1/8		
	1 3/16	1.1875	—	—	18	—	—	—	—	—	—	—	—	8	12	16	20	28	—	1 3/16		
1 1/4		1.2500	7	12	18	—	—	—	—	—	—	—	—	8	UNF	16	20	28	—	1 1/4		
	1 5/16	1.3125	—	—	18	—	—	—	—	—	—	—	—	8	12	16	20	28	—	1 5/16		
1 3/8		1.3750	6	12	18	—	—	—	—	—	—	—	—	8	UNF	16	20	28	—	1 3/8		
	1 7/16	1.4375	—	—	18	—	—	—	—	—	—	—	—	6	8	12	16	20	28	—	1 7/16	
1 1/2		1.5000	6	12	18	—	—	—	—	—	—	—	—	UNC	8	UNF	16	20	28	—	1 1/2	
	1 9/16	1.5625	—	—	18	—	—	—	—	—	—	—	—	6	8	12	16	20	—	—	1 9/16	
1 5/8		1.6250	—	—	18	—	—	—	—	—	—	—	—	6	8	12	16	20	—	—	1 5/8	
	1 11/16	1.6875	—	—	18	—	—	—	—	—	—	—	—	6	8	12	16	20	—	—	1 11/16	
1 3/4		1.7500	5	—	—	—	—	—	—	—	—	—	—	6	8	12	16	20	—	—	1 3/4	
	1 13/16	1.8125	—	—	—	—	—	—	—	—	—	—	—	6	8	12	16	20	—	—	1 13/16	
1 7/8		1.8750	—	—	—	—	—	—	—	—	—	—	—	6	8	12	16	20	—	—	1 7/8	
	1 5/8	1.9375	—	—	—	—	—	—	—	—	—	—	—	6	8	12	16	20	—	—	1 5/8	
2		2.0000	4 1/2	—	—	—	—	—	—	—	—	—	—	—	—	—	—	—	—	—	2	
	2 1/8	2.1250	—	—	—	—	—	—	—	—	—	—	—	6	8	12	16	20	—	—	2 1/8	
2 1/4		2.2500	4 1/2	—	—	—	—	—	—	—	—	—	—	6	8	12	16	20	—	—	2 1/4	
	2 3/8	2.3750	—	—	—	—	—	—	—	—	—	—	—	6	8	12	16	20	—	—	2 3/8	
2 1/2		2.5000	4	—	—	—	—	—	—	—	—	—	—	UNC	6	8	12	16	20	—	2 1/2	
	2 5/8	2.6250	—	—	—	—	—	—	—	—	—	—	—	4	6	8	12	16	20	—	2 5/8	
2 3/4		2.7500	4	—	—	—	—	—	—	—	—	—	—	UNC	6	8	12	16	20	—	2 3/4	
	2 7/8	2.8750	—	—	—	—	—	—	—	—	—	—	—	4	6	8	12	16	20	—	2 7/8	
3		3.0000	4	—	—	—	—	—	—	—	—	—	—	—	—	—	—	—	—	—	3	
	3 1/8	3.1250	—	—	—	—	—	—	—	—	—	—	—	UNC	4	6	8	12	16	—	—	3 1/8
3 1/4		3.2500	4	—	—	—	—	—	—	—	—	—	—	UNC	6	8	12	16	—	—	3 1/4	
	3 3/8	3.3750	—	—	—	—	—	—	—	—	—	—	—	4	6	8	12	16	—	—	3 3/8	
3 1/2		3.5000	4	—	—	—	—	—	—	—	—	—	—	UNC	6	8	12	16	—	—	3 1/2	
	3 5/8	3.6250	—	—	—	—	—	—	—	—	—	—	—	4	6	8	12	16	—	—	3 5/8	
3 3/4		3.7500	4	—	—	—	—	—	—	—	—	—	—	UNC	6	8	12	16	—	—	3 3/4	
	3 7/8	3.8750	—	—	—	—	—	—	—	—	—	—	—	4	6	8	12	16	—	—	3 7/8	
4		4.0000	4	—	—	—	—	—	—	—	—	—	—	—	—	—	—	—	—	—	4	
	4 1/8	4.1250	—	—	—	—	—	—	—	—	—	—	—	UNC	4	6	8	12	16	—	—	4 1/8
4 1/4		4.2500	—	—	—	—	—	—	—	—	—	—	—	4	6	8	12	16	—	—	4 1/4	
	4 3/8	4.3750	—	—	—	—	—	—	—	—	—	—	—	4	6	8	12	16	—	—	4 3/8	
4 1/2		4.5000	—	—	—	—	—	—	—	—	—	—	—	4	6	8	12	16	—	—	4 1/2	
	4 5/8	4.6250	—	—	—	—	—	—	—	—	—	—	—	4	6	8	12	16	—	—	4 5/8	
4 3/4		4.7500	—	—	—	—	—	—	—	—	—	—	—	4	6	8	12	16	—	—	4 3/4	
	4 7/8	4.8750	—	—	—	—	—	—	—	—	—	—	—	4	6	8	12	16	—	—	4 7/8	
5		5.0000	—	—	—	—	—	—	—	—	—	—	—	—	—	—	—	—	—	—	5	
	5 1/8	5.1250	—	—	—	—	—	—	—	—	—	—	—	4	6	8	12	16	—	—	5 1/8	
5 1/4		5.2500	—	—	—	—	—	—	—	—	—	—	—	4	6	8	12	16	—	—	5 1/4	
	5 3/8	5.3750	—	—	—	—	—	—	—	—	—	—	—	4	6	8	12	16	—	—	5 3/8	
5 1/2		5.5000	—	—	—	—	—	—	—	—	—	—	—	4	6	8	12	16	—	—	5 1/2	
	5 5/8	5.6250	—	—	—	—	—	—	—	—	—	—	—	4	6	8	12	16	—	—	5 5/8	
5 3/4		5.7500	—	—	—	—	—	—	—	—	—	—	—	4	6	8	12	16	—	—	5 3/4	
	5 7/8	5.8750	—	—	—	—	—	—	—	—	—	—	—	4	6	8	12	16	—	—	5 7/8	
6		6.0000	—	—	—	—	—	—	—	—	—	—	—	—	—	—	—	—	—	—	6	













## APPENDIX K

### METRIC SCREW THREAD VARIATIONS

THE FOLLOWING list is a ready reference of available standard coarse pitch series ISO metric screw threads. Each thread is given as part of a proper thread note, including metric symbol, major diameter, and thread pitch.

M1 × 0.25	M2.2 × 0.45	M6 × 1	M14 × 2	M30 × 3.5	M52 × 5
M1.1 × 0.25	M2.5 × 0.45	M7 × 1	M16 × 2	M33 × 3.5	M56 × 5.5
M1.2 × 0.25	M3 × 0.5	M8 × 1.25	M18 × 2.5	M36 × 4	M60 × 5.5
M1.4 × 0.3	M3.5 × 0.6	M9 × 1.25	M20 × 2.5	M39 × 4	M64 × 6
M1.6 × 0.35	M4 × 0.7	M10 × 1.5	M22 × 2.5	M42 × 4.5	M68 × 6
M1.8 × 0.35	M4.5 × 0.75	M11 × 1.5	M24 × 3	M45 × 4.5	
M2 × 0.4	M5 × 0.8	M12 × 1.75	M27 × 3	M48 × 5	

## APPENDIX L ASTM AND SAE GRADE MARKINGS FOR STEEL BOLTS AND SCREWS

ASTM AND SAE GRADE MARKINGS FOR STEEL BOLTS AND SCREWS		
Grade Marking	Specification	Material
 NO MARK	SAE—Grade 1	Low or Medium Carbon Steel
	ASTM—A 307	Low Carbon Steel
	SAE—Grade 2	Low or Medium Carbon Steel
	SAE—Grade 5	Medium Carbon Steel, Quenched and Tempered
	ASTM—A 449	
	SAE—Grade 5.2	Low Carbon Martensite Steel, Quenched and Tempered
	ASTM—A 325 Type 1	Medium Carbon Steel, Quenched and Tempered Radial dashes optional
	ASTM—A 325 Type 2	Low Carbon Martensite Steel, Quenched and Tempered
	ASTM—A 325 Type 3	Atmospheric Corrosion (Weathering) Steel, Quenched and Tempered
	ASTM—A 354 Grade BC	Alloy Steel, Quenched and Tempered
	SAE—Grade 7	Medium Carbon Alloy Steel, Quenched and Tempered, Roll Threaded After Heat Treatment
	SAE—Grade 8	Medium Carbon Alloy Steel, Quenched and Tempered
	ASTM—A 354 Grade BD	Alloy Steel, Quenched and Tempered
	SAE—Grade 8.2	Low Carbon Martensite Steel, Quenched and Tempered
	ASTM—A 490 Type 1	Alloy Steel, Quenched and Tempered
	ASTM—A 490 Type 3	Atmospheric Corrosion (Weathering) Steel, Quenched and Tempered

Reprinted from The American Society of Mechanical Engineers—ANSI B18.2.1-1981 (R1992).



**APPENDIX M**  
**CAP SCREW SPECIFICATIONS**

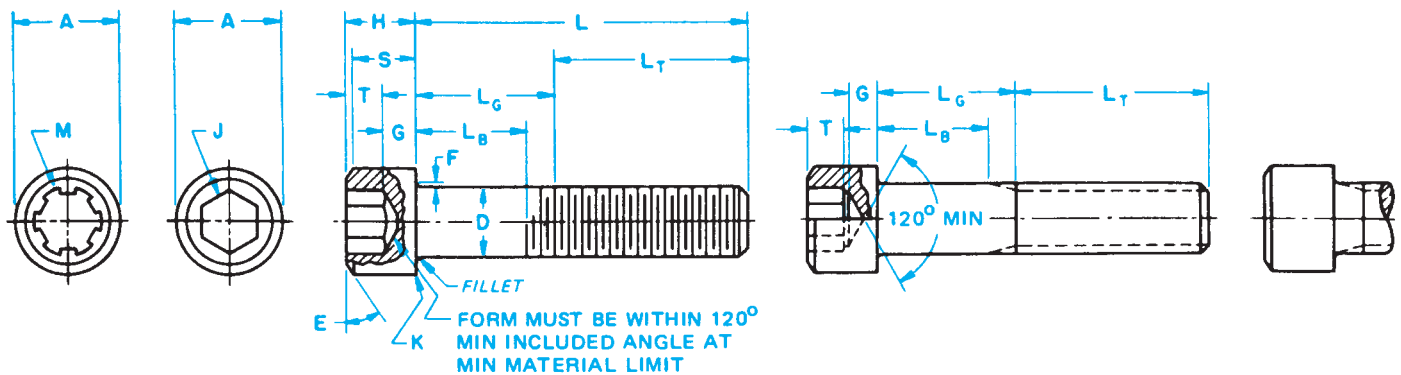
**TABLE 10 DIMENSIONS OF HEX CAP SCREWS (FINISHED HEX BOLTS)**

Nominal Size or Basic Product Dia (18)	E		F		G		H		J		L <sub>T</sub>		Y	Runout of Bearing Surface FIM (5)	
	Max	Min	Width Across Flats		Width Across Corners (4)		Height		Min	Max	Thread Length For Screw Lengths (10)		Transition Thread Length (10)	Max	Max
			Basic	Max	Min	Max	Basic	Over 6 in. and Shorter			Basic	Max			
1/4	0.2500	0.2450	0.438	0.428	0.488	0.505	0.163	0.150	0.106	0.750	1.000	0.250	0.010		
5/16	0.3125	0.3065	0.500	0.489	0.577	0.577	0.211	0.195	0.140	0.875	1.125	0.278	0.011		
3/8	0.3750	0.3690	0.562	0.551	0.650	0.650	0.243	0.226	0.160	1.000	1.250	0.312	0.012		
7/16	0.4375	0.4305	0.625	0.612	0.722	0.722	0.291	0.272	0.195	1.125	1.375	0.357	0.013		
1/2	0.5000	0.4930	0.750	0.736	0.866	0.866	0.323	0.302	0.215	1.250	1.500	0.385	0.014		
9/16	0.5625	0.5545	0.812	0.798	0.938	0.938	0.371	0.348	0.250	1.375	1.625	0.417	0.015		
5/8	0.6250	0.6170	0.938	0.922	1.083	1.083	0.403	0.378	0.269	1.500	1.750	0.455	0.017		
3/4	0.7500	0.7410	1.125	1.100	1.299	1.299	0.483	0.455	0.324	1.750	2.000	0.500	0.020		
7/8	0.8750	0.8660	1.312	1.285	1.516	1.516	0.563	0.531	0.378	2.000	2.250	0.556	0.023		
1	1.0000	0.9900	1.500	1.469	1.732	1.732	0.627	0.591	0.416	2.250	2.500	0.625	0.026		
1 1/8	1.1250	1.1140	1.688	1.631	1.949	1.949	0.718	0.658	0.461	2.500	2.750	0.714	0.029		
1 1/4	1.2500	1.2390	1.875	1.812	2.165	2.165	0.813	0.749	0.530	2.750	3.000	0.714	0.033		
1 3/8	1.3750	1.3630	2.062	1.994	2.382	2.382	0.878	0.810	0.569	3.000	3.250	0.833	0.036		
1 1/2	1.5000	1.4880	2.230	2.175	2.598	2.598	0.974	0.902	0.640	3.250	3.500	0.833	0.039		
1 3/4	1.7500	1.7380	2.625	2.538	3.031	3.031	1.134	1.054	0.748	3.750	4.000	1.000	0.046		
2	2.0000	1.9880	3.000	2.900	3.464	3.464	1.263	1.175	0.825	4.250	4.500	1.111	0.052		
2 1/4	2.2500	2.2380	3.375	3.262	3.897	3.897	1.423	1.327	0.933	4.750	5.000	1.111	0.059		
2 1/2	2.5000	2.4880	3.750	3.625	4.330	4.330	1.583	1.479	1.042	5.250	5.500	1.250	0.065		
2 3/4	2.7500	2.7380	4.125	3.988	4.763	4.763	1.744	1.632	1.151	5.750	6.000	1.250	0.072		
3	3.0000	2.9880	4.500	4.350	5.196	5.196	1.935	1.815	1.290	6.250	6.500	1.250	0.079		

Reprinted from The American Society of Mechanical Engineers.

APPENDIX M (Continued)

**TABLE 11 DIMENSIONS OF HEXAGON AND SPLINE SOCKET HEAD CAP SCREWS (1960 SERIES)**

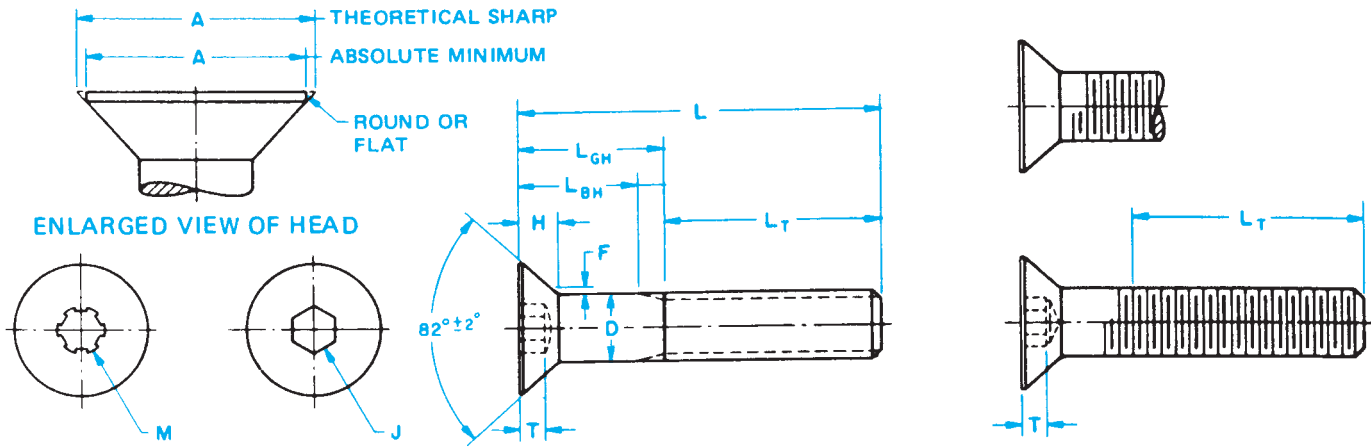


Nominal Size or Basic Screw Diameter	D		A		H		S	M	J	T	G	K	
	Body Diameter		Head Diameter		Head Height		Head Side Height	Spline Socket Size	Hexagon Socket Size	Key Engagement	Wall Thickness	Chamfer or Radius	
	Max	Min	Max	Min	Max	Min	Min	Nom	Nom	Min	Min	Max	
0	0.0600	0.0600	0.0568	0.096	0.091	0.060	0.057	0.054	0.060	0.050	0.025	0.020	0.003
1	0.0730	0.0730	0.0695	0.118	0.112	0.073	0.070	0.066	0.072	1/16 0.062	0.031	0.025	0.003
2	0.0860	0.0860	0.0822	0.140	0.134	0.086	0.083	0.077	0.096	5/64 0.078	0.038	0.029	0.003
3	0.0990	0.0990	0.0949	0.161	0.154	0.099	0.095	0.089	0.096	5/64 0.078	0.044	0.034	0.003
4	0.1120	0.1120	0.1075	0.183	0.176	0.112	0.108	0.101	0.111	3/32 0.094	0.051	0.038	0.005
5	0.1250	0.1250	0.1202	0.205	0.198	0.125	0.121	0.112	0.111	3/32 0.094	0.057	0.043	0.005
6	0.1380	0.1380	0.1329	0.226	0.218	0.138	0.134	0.124	0.133	7/64 0.109	0.064	0.047	0.005
8	0.1640	0.1640	0.1585	0.270	0.262	0.164	0.159	0.148	0.168	9/64 0.141	0.077	0.056	0.005
10	0.1900	0.1900	0.1840	0.312	0.303	0.190	0.185	0.171	0.183	5/52 0.156	0.090	0.065	0.005
1/4	0.2500	0.2500	0.2435	0.375	0.365	0.250	0.244	0.225	0.216	3/16 0.188	0.120	0.095	0.008
5/16	0.3125	0.3125	0.3053	0.469	0.457	0.312	0.306	0.281	0.291	1/4 0.250	0.151	0.119	0.008
3/8	0.3750	0.3750	0.3678	0.562	0.550	0.375	0.368	0.337	0.372	5/16 0.312	0.182	0.143	0.008
7/16	0.4375	0.4375	0.4294	0.656	0.642	0.438	0.430	0.394	0.454	3/8 0.375	0.213	0.166	0.010
1/2	0.5000	0.5000	0.4919	0.750	0.735	0.500	0.492	0.450	0.454	3/8 0.375	0.245	0.190	0.010
5/8	0.6250	0.6250	0.6163	0.938	0.921	0.625	0.616	0.562	0.595	1/2 0.500	0.307	0.238	0.010
3/4	0.7500	0.7500	0.7406	1.125	1.107	0.750	0.740	0.675	0.620	5/8 0.625	0.370	0.285	0.010
7/8	0.8750	0.8750	0.8647	1.312	1.293	0.875	0.864	0.787	0.698	3/4 0.750	0.432	0.333	0.015
1	1.0000	1.0000	0.9886	1.500	1.479	1.000	0.988	0.900	0.790	3/4 0.750	0.495	0.380	0.015
1 1/8	1.1250	1.1250	1.1086	1.688	1.665	1.125	1.111	1.012	.....	7/8 0.875	0.557	0.428	0.015
1 1/4	1.2500	1.2500	1.2336	1.875	1.852	1.250	1.236	1.125	.....	7/8 0.875	0.620	0.475	0.015
1 3/8	1.3750	1.3750	1.3568	2.062	2.038	1.375	1.360	1.237	.....	1 1.000	0.682	0.523	0.015
1 1/2	1.5000	1.5000	1.4818	2.250	2.224	1.500	1.485	1.350	.....	1 1.000	0.745	0.570	0.015
1 3/4	1.7500	1.7500	1.7295	2.625	2.597	1.750	1.734	1.575	.....	1 1/4 1.250	0.870	0.665	0.015
2	2.0000	2.0000	1.9780	3.000	2.970	2.000	1.983	1.800	.....	1 1/2 1.500	0.995	0.760	0.015
2 1/4	2.2500	2.2500	2.2280	3.375	3.344	2.250	2.232	2.025	.....	1 3/4 1.750	1.120	0.855	0.031
2 1/2	2.5000	2.5000	2.4762	3.750	3.717	2.500	2.481	2.250	.....	1 3/4 1.750	1.245	0.950	0.031
2 3/4	2.7500	2.7500	2.7262	4.125	4.090	2.750	2.730	2.475	.....	2 2.000	1.370	1.045	0.031
3	3.0000	3.0000	2.9762	4.500	4.464	3.000	2.979	2.700	.....	2 1/4 2.250	1.495	1.140	0.031
3 1/4	3.2500	3.2500	3.2262	4.875	4.837	3.250	3.228	2.925	.....	2 1/4 2.250	1.620	1.235	0.031
3 1/2	3.5000	3.5000	3.4762	5.250	5.211	3.500	3.478	3.150	.....	2 3/4 2.750	1.745	1.330	0.031
3 3/4	3.7500	3.7500	3.7262	5.625	5.584	3.750	3.727	3.375	.....	2 3/4 2.750	1.870	1.425	0.031
4	4.0000	4.0000	3.9762	6.000	5.958	4.000	3.976	3.600	.....	3 3.000	1.995	1.520	0.031

Reprinted from The American Society of Mechanical Engineers—ANSI/ASME B18.3-1986 (R1993).

APPENDIX M (Continued)

TABLE 12 DIMENSIONS OF HEXAGON AND SPLINE SOCKET FLAT COUNTERSUNK HEAD CAP SCREWS



Nominal Size or Basic Screw Diameter	D		A		H		M	J	T	F	
	Body Diameter		Head Diameter		Head Height						
	Max	Min	Theoretical Sharp Max	Abs. Min	Reference	Flushness Tolerance	Hexagon Socket Size Nom	Key Engagement Min	Fillet Extension Above D Max		
0	0.0600	0.0600	0.0568	0.138	0.117	0.044	0.006	0.048	0.035	0.025	0.006
1	0.0730	0.0730	0.0695	0.168	0.143	0.054	0.007	0.060	0.050	0.031	0.008
2	0.0860	0.0860	0.0822	0.197	0.168	0.064	0.008	0.060	0.050	0.038	0.010
3	0.0990	0.0990	0.0949	0.226	0.193	0.073	0.010	0.072	1/16 0.062	0.044	0.010
4	0.1120	0.1120	0.1075	0.255	0.218	0.083	0.011	0.072	1/16 0.062	0.055	0.012
5	0.1250	0.1250	0.1202	0.281	0.240	0.090	0.012	0.096	5/64 0.078	0.061	0.014
6	0.1380	0.1380	0.1329	0.307	0.263	0.097	0.013	0.096	5/64 0.078	0.066	0.015
8	0.1640	0.1640	0.1585	0.359	0.311	0.112	0.014	0.111	3/32 0.094	0.076	0.015
10	0.1900	0.1900	0.1840	0.411	0.359	0.127	0.015	0.145	1/8 0.125	0.087	0.015
1/4	0.2500	0.2500	0.2435	0.531	0.480	0.161	0.016	0.183	5/32 0.156	0.111	0.015
5/16	0.3125	0.3125	0.3053	0.656	0.600	0.198	0.017	0.216	3/16 0.188	0.135	0.015
3/8	0.3750	0.3750	0.3678	0.781	0.720	0.234	0.018	0.251	7/32 0.219	0.159	0.015
7/16	0.4375	0.4375	0.4294	0.844	0.781	0.234	0.018	0.291	1/4 0.250	0.159	0.015
1/2	0.5000	0.5000	0.4919	0.938	0.872	0.251	0.018	0.372	5/16 0.312	0.172	0.015
5/8	0.6250	0.6250	0.6163	1.188	1.112	0.324	0.022	0.454	3/8 0.375	0.220	0.015
3/4	0.7500	0.7500	0.7406	1.438	1.355	0.396	0.024	0.454	1/2 0.500	0.220	0.015
7/8	0.8750	0.8750	0.8647	1.688	1.604	0.468	0.025	...	9/16 0.562	0.248	0.015
1	1.0000	1.0000	0.9886	1.938	1.841	0.540	0.028	...	5/8 0.625	0.297	0.015
1 1/8	1.1250	1.1250	1.1086	2.188	2.079	0.611	0.031	...	3/4 0.750	0.325	0.031
1 1/4	1.2500	1.2500	1.2336	2.438	2.316	0.683	0.035	...	7/8 0.875	0.358	0.031
1 3/8	1.3750	1.3750	1.3568	2.688	2.553	0.755	0.038	...	7/8 0.875	0.402	0.031
1 1/2	1.5000	1.5000	1.4818	2.938	2.791	0.827	0.042	...	1 1.000	0.435	0.031

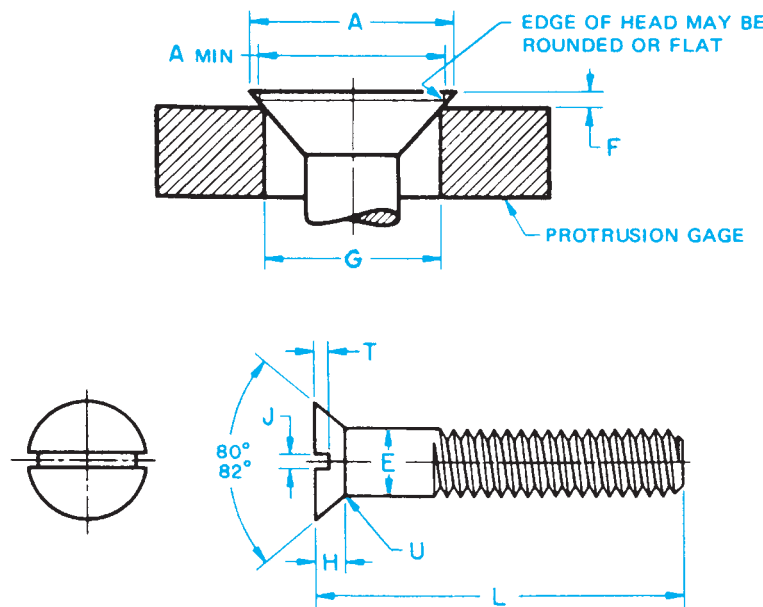
Reprinted from The American Society of Mechanical Engineers—ANSI/ASME B18.3-1986 (R1993).

APPENDIX M (Continued)

**TABLE 13 DIMENSIONS OF SLOTTED FLAT COUNTERSUNK HEAD CAP SCREWS**

**CAP SCREWS**  
**FLAT**

Type of Head



Nominal Size <sup>1</sup> or Basic Screw Diameter	E		A		H <sup>2</sup>	J		T		U	F <sup>3</sup>		G <sup>3</sup>
	Body Diameter		Head Diameter			Head Height	Slot Width		Slot Depth		Fillet Radius	Protrusion Above Gaging Diameter	
	Max	Min	Max, Edge Sharp	Min, Edge Rounded or Flat	Ref		Max	Min	Max	Min	Max	Max	Min
1/4	0.2500	0.2500	0.2450	0.500	0.140	0.075	0.064	0.068	0.045	0.100	0.046	0.030	0.424
5/16	0.3125	0.3125	0.3070	0.625	0.177	0.084	0.072	0.086	0.057	0.125	0.053	0.035	0.538
3/8	0.3750	0.3750	0.3690	0.750	0.210	0.094	0.081	0.103	0.068	0.150	0.060	0.040	0.651
7/16	0.4375	0.4375	0.4310	0.812	0.210	0.094	0.081	0.103	0.068	0.175	0.065	0.044	0.703
1/2	0.5000	0.5000	0.4930	0.875	0.210	0.106	0.091	0.103	0.068	0.200	0.071	0.049	0.756
9/16	0.5625	0.5625	0.5550	1.000	0.244	0.118	0.102	0.120	0.080	0.225	0.078	0.054	0.869
5/8	0.6250	0.6250	0.6170	1.125	0.281	0.133	0.116	0.137	0.091	0.250	0.085	0.058	0.982
3/4	0.7500	0.7500	0.7420	1.375	0.352	0.149	0.131	0.171	0.115	0.300	0.099	0.068	1.208
7/8	0.8750	0.8750	0.8660	1.625	0.423	0.167	0.147	0.206	0.138	0.350	0.113	0.077	1.435
1	1.0000	1.0000	0.9900	1.875	0.494	0.188	0.166	0.240	0.162	0.400	0.127	0.087	1.661
1 1/8	1.1250	1.1250	1.1140	2.062	0.529	0.196	0.178	0.257	0.173	0.450	0.141	0.096	1.826
1 1/4	1.2500	1.2500	1.2390	2.312	0.600	0.211	0.193	0.291	0.197	0.500	0.155	0.105	2.052
1 3/8	1.3750	1.3750	1.3630	2.562	0.665	0.226	0.208	0.326	0.220	0.550	0.169	0.115	2.279
1 1/2	1.5000	1.5000	1.4880	2.812	0.742	0.258	0.240	0.360	0.244	0.600	0.183	0.124	2.505

<sup>1</sup> Where specifying nominal size in decimals, zeros preceding decimal and in the fourth decimal place shall be omitted.

<sup>2</sup> Tabulated values determined from formula for maximum H, Appendix III.

<sup>3</sup> No tolerance for gaging diameter is given. If the gaging diameter of the gage used differs from tabulated value, the protrusion will be affected accordingly and the proper protrusion values must be recalculated using the formulas shown in Appendix II.

FOOTNOTES REFER TO ANSI B18.6.2-1972 (R1993).

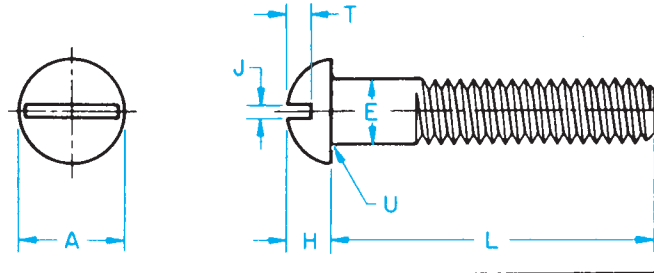
Reprinted from The American Society of Mechanical Engineers—ANSI B18.6.2-1972 (R1993).

APPENDIX M (Continued)

TABLE 14 DIMENSIONS OF SLOTTED ROUND HEAD CAP SCREWS

**CAP SCREWS**  
**ROUND**

Type of Head



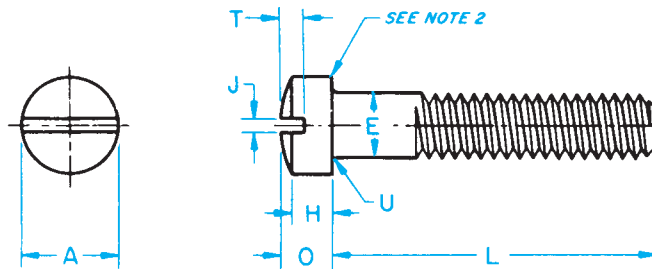
Nominal Size <sup>1</sup> or Basic Screw Diameter	E		A		H		J		T		U		
	Body Diameter		Head Diameter		Head Height		Slot Width		Slot Depth		Fillet Radius		
	Max	Min	Max	Min	Max	Min	Max	Min	Max	Min	Max	Min	
1/4	0.2500	0.2500	0.2450	0.437	0.418	0.191	0.175	0.075	0.064	0.117	0.097	0.031	0.016
5/16	0.3125	0.3125	0.3070	0.562	0.540	0.245	0.226	0.084	0.072	0.151	0.126	0.031	0.016
3/8	0.3750	0.3750	0.3690	0.625	0.603	0.273	0.252	0.094	0.081	0.168	0.138	0.031	0.016
7/16	0.4375	0.4375	0.4310	0.750	0.725	0.328	0.302	0.094	0.081	0.202	0.167	0.047	0.016
1/2	0.5000	0.5000	0.4930	0.812	0.786	0.354	0.327	0.106	0.091	0.218	0.178	0.047	0.016
9/16	0.5625	0.5625	0.5550	0.937	0.909	0.409	0.378	0.118	0.102	0.252	0.207	0.047	0.016
5/8	0.6250	0.6250	0.6170	1.000	0.970	0.437	0.405	0.133	0.116	0.270	0.220	0.062	0.031
3/4	0.7500	0.7500	0.7420	1.250	1.215	0.546	0.507	0.149	0.131	0.338	0.278	0.062	0.031

<sup>1</sup>Where specifying nominal size in decimals, zeros preceding decimal and in the fourth decimal place shall be omitted.  
Reprinted from The American Society of Mechanical Engineers—ANSI B18.6.2-1972.

TABLE 15 DIMENSIONS OF SLOTTED FILLISTER HEAD CAP SCREWS

**CAP SCREWS**  
**FILLISTER**

Type of Head



Nominal Size <sup>1</sup> or Basic Screw Diameter	E		A		H		O		J		T		U		
	Body Diameter		Head Diameter		Head Side Height		Total Head Height		Slot Width		Slot Depth		Fillet Radius		
	Max	Min	Max	Min	Max	Min	Max	Min	Max	Min	Max	Min	Max	Min	
1/4	0.2500	0.2500	0.2450	0.375	0.363	0.172	0.157	0.216	0.194	0.075	0.064	0.097	0.077	0.031	0.016
5/16	0.3125	0.3125	0.3070	0.437	0.424	0.203	0.186	0.253	0.230	0.084	0.072	0.115	0.090	0.031	0.016
3/8	0.3750	0.3750	0.3690	0.562	0.547	0.250	0.229	0.314	0.284	0.094	0.081	0.142	0.112	0.031	0.016
7/16	0.4375	0.4375	0.4310	0.625	0.608	0.297	0.274	0.368	0.336	0.094	0.081	0.168	0.133	0.047	0.016
1/2	0.5000	0.5000	0.4930	0.750	0.731	0.328	0.301	0.413	0.376	0.106	0.091	0.193	0.153	0.047	0.016
9/16	0.5625	0.5625	0.5550	0.812	0.792	0.375	0.346	0.467	0.427	0.118	0.102	0.213	0.168	0.047	0.016
5/8	0.6250	0.6250	0.6170	0.875	0.853	0.422	0.391	0.521	0.478	0.133	0.116	0.239	0.189	0.062	0.031
3/4	0.7500	0.7500	0.7420	1.000	0.976	0.500	0.466	0.612	0.566	0.149	0.131	0.283	0.223	0.062	0.031
7/8	0.8750	0.8750	0.8660	1.125	1.098	0.594	0.556	0.720	0.668	0.167	0.147	0.334	0.264	0.062	0.031
1	1.0000	1.0000	0.9900	1.312	1.282	0.656	0.612	0.803	0.743	0.188	0.166	0.371	0.291	0.062	0.031

<sup>1</sup>Where specifying nominal size in decimals, zeros preceding decimal and in the fourth decimal place shall be omitted.

<sup>2</sup>A slight rounding of the edges at periphery of head shall be permissible provided the diameter of the bearing circle is equal to no less than 90 percent of the specified minimum head diameter.

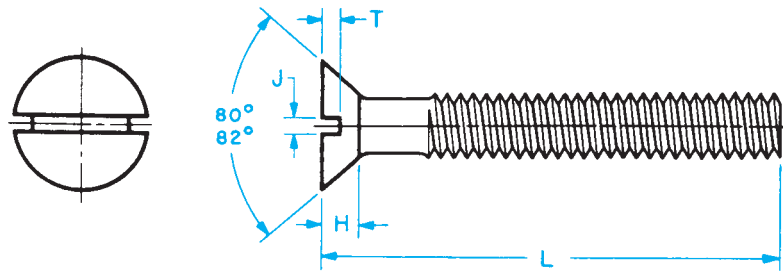
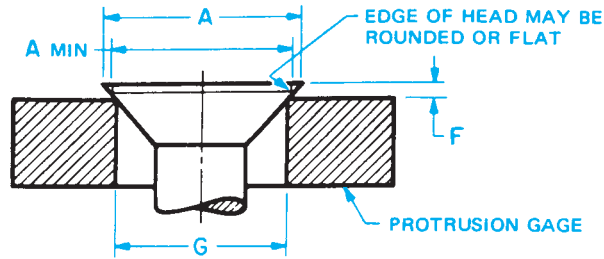
Reprinted from The American Society of Mechanical Engineers—ANSI B18.6.2-1972.

**APPENDIX N  
MACHINE SCREW SPECIFICATIONS**

**TABLE 16 DIMENSIONS OF SLOTTED FLAT COUNTERSUNK HEAD MACHINE SCREWS**



Type of Head



Nominal Size <sup>1</sup> or Basic Screw Diameter	L <sup>2</sup>	A		H <sup>3</sup>	J		T		F <sup>4</sup>		G <sup>4</sup>	
		Head Diameter			Slot Width	Slot Depth	Protrusion Above Gaging Diameter					
		Max, Edge Sharp	Min, Edge Rounded or Flat	Head Height			Max	Min	Max	Min		
		Ref	Max	Min	Max	Min	Max	Min				
0000	0.0210	—	0.043	0.037	0.011	0.008	0.004	0.007	0.003	*	*	*
000	0.0340	—	0.064	0.058	0.016	0.011	0.007	0.009	0.005	*	*	*
00	0.0470	—	0.093	0.085	0.028	0.017	0.010	0.014	0.009	*	*	*
0	0.0600	1/8	0.119	0.099	0.035	0.023	0.016	0.015	0.010	0.026	0.016	0.078
1	0.0730	1/8	0.146	0.123	0.043	0.026	0.019	0.019	0.012	0.028	0.016	0.101
2	0.0860	1/8	0.172	0.147	0.051	0.031	0.023	0.023	0.015	0.029	0.017	0.124
3	0.0990	1/8	0.199	0.171	0.059	0.035	0.027	0.027	0.017	0.031	0.018	0.148
4	0.1120	3/16	0.225	0.195	0.067	0.039	0.031	0.030	0.020	0.032	0.019	0.172
5	0.1250	3/16	0.252	0.220	0.075	0.043	0.035	0.034	0.022	0.034	0.020	0.196
6	0.1380	3/16	0.279	0.244	0.083	0.048	0.039	0.038	0.024	0.036	0.021	0.220
8	0.1640	1/4	0.332	0.292	0.100	0.054	0.045	0.045	0.029	0.039	0.023	0.267
10	0.1900	5/16	0.385	0.340	0.116	0.060	0.050	0.053	0.034	0.042	0.025	0.313
12	0.2160	3/8	0.438	0.389	0.132	0.067	0.056	0.060	0.039	0.045	0.027	0.362
1/4	0.2500	7/16	0.507	0.452	0.153	0.075	0.064	0.070	0.046	0.050	0.029	0.424
5/16	0.3125	1/2	0.635	0.568	0.191	0.084	0.072	0.088	0.058	0.057	0.034	0.539
3/8	0.3750	9/16	0.762	0.685	0.230	0.094	0.081	0.106	0.070	0.065	0.039	0.653
7/16	0.4375	5/8	0.812	0.723	0.223	0.094	0.081	0.103	0.066	0.073	0.044	0.690
1/2	0.5000	3/4	0.875	0.775	0.223	0.106	0.091	0.103	0.065	0.081	0.049	0.739
9/16	0.5625	—	1.000	0.889	0.260	0.118	0.102	0.120	0.077	0.089	0.053	0.851
5/8	0.6250	—	1.125	1.002	0.298	0.133	0.116	0.137	0.088	0.097	0.058	0.962
3/4	0.7500	—	1.375	1.230	0.372	0.149	0.131	0.171	0.111	0.112	0.067	1.186

<sup>1</sup> Where specifying nominal size in decimals, zeros preceding decimal and in the fourth decimal place shall be omitted.

<sup>2</sup> Screws of these lengths and shorter shall have undercut heads as shown in Table 5.

<sup>3</sup> Tabulated values determined from formula for maximum H, Appendix V.

<sup>4</sup> No tolerance for gaging diameter is given. If the gaging diameter of the gage used differs from tabulated value, the protrusion will be affected accordingly and the proper protrusion values must be recalculated using the formulas shown in Appendix I.

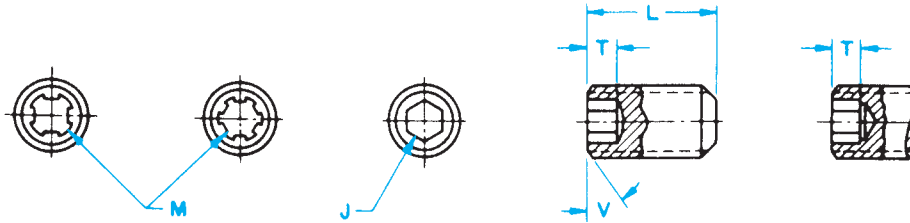
\* Not practical to gage.

FOOTNOTES REFER TO ANSI B18.6.3-1972 (R1991).

Reprinted from The American Society of Mechanical Engineers—ANSI B18.6.3-1972 (R1991).

**APPENDIX O**  
**SET SCREW SPECIFICATIONS**

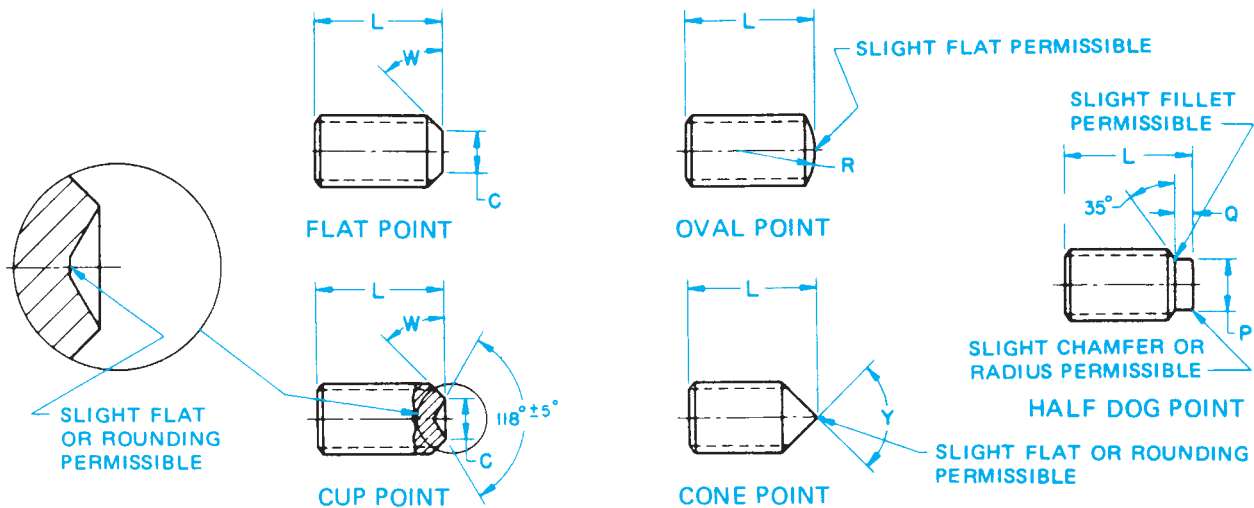
**TABLE 17 DIMENSIONS OF HEXAGON AND SPLINE SOCKET SET SCREWS**



Nominal Size or Basic Screw Diameter	J		M	T		C		R	Y Cone Point Angle 90° ±2° for These Nominal Lengths or Longer; 118° ±2° for Shorter Nominal Lengths
	Hexagon Socket Size		Spline Socket Size	Min Key Engagement to Develop Functional Capability of Key		Cup and Flat Point Diameters		Oval Point Radius	
	Nom	Nom	Hex Socket T <sub>H</sub> Min	Spline Socket T <sub>S</sub> Min	Max	Min	Basic		
0	0.0600	0.028	0.033	0.050	0.026	0.033	0.027	0.045	5/64
1	0.0730	0.035	0.033	0.060	0.035	0.040	0.033	0.055	3/32
2	0.0860	0.035	0.048	0.060	0.040	0.047	0.039	0.064	7/64
3	0.0990	0.050	0.048	0.070	0.040	0.054	0.045	0.074	1/8
4	0.1120	0.050	0.060	0.070	0.045	0.061	0.051	0.084	5/32
5	0.1250	1/16 0.062	0.072	0.080	0.055	0.067	0.057	0.094	3/16
6	0.1380	1/16 0.062	0.072	0.080	0.055	0.074	0.064	0.104	3/16
8	0.1640	5/64 0.078	0.096	0.090	0.080	0.087	0.076	0.123	1/4
10	0.1900	3/32 0.094	0.111	0.100	0.080	0.102	0.088	0.142	1/4
1/4	0.2500	1/8 0.125	0.145	0.125	0.125	0.132	0.118	0.188	5/16
5/16	0.3125	5/32 0.156	0.183	0.156	0.156	0.172	0.156	0.234	3/8
3/8	0.3750	3/16 0.188	0.216	0.188	0.188	0.212	0.194	0.281	7/16
7/16	0.4375	7/32 0.219	0.251	0.219	0.219	0.252	0.232	0.328	1/2
1/2	0.5000	1/4 0.250	0.291	0.250	0.250	0.291	0.270	0.375	9/16
5/8	0.6250	5/16 0.312	0.372	0.312	0.312	0.371	0.347	0.469	3/4
3/4	0.7500	3/8 0.375	0.454	0.375	0.375	0.450	0.425	0.562	7/8
7/8	0.8750	1/2 0.500	0.595	0.500	0.500	0.530	0.502	0.656	1
1	1.0000	9/16 0.562	...	0.562	...	0.609	0.579	0.750	1 1/8
1 1/8	1.1250	9/16 0.562	...	0.562	...	0.689	0.655	0.844	1 1/4
1 1/4	1.2500	5/8 0.625	...	0.625	...	0.767	0.733	0.938	1 1/2
1 3/8	1.3750	5/8 0.625	...	0.625	...	0.848	0.808	1.031	1 5/8
1 1/2	1.5000	3/4 0.750	...	0.750	...	0.926	0.886	1.125	1 3/4
1 3/4	1.7500	1 1.000	...	1.000	...	1.086	1.039	1.312	2
2	2.0000	1 1.000	...	1.000	...	1.244	1.193	1.500	2 1/4

APPENDIX O (Continued)

**TABLE 17 (CONTINUED)—DIMENSIONS OF HEXAGON AND SPLINE SOCKET SET SCREWS**



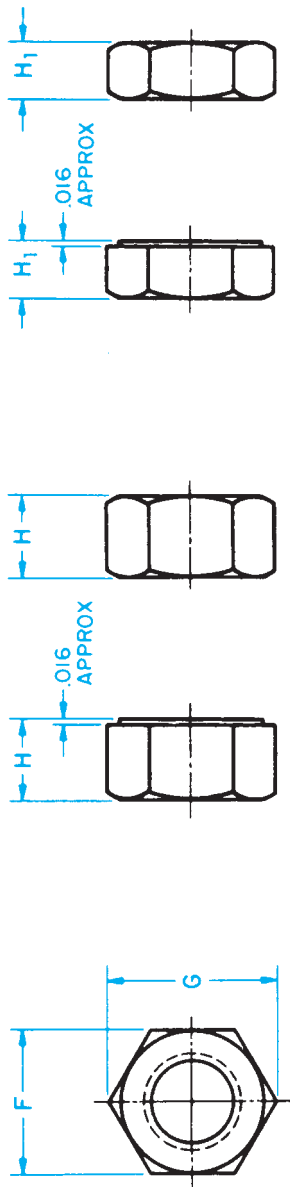
Nominal Size or Basic Screw Diameter	P		Q		B			B1			
	Half Dog Point				Shortest Optimum Nominal Length To Which Column T <sub>H</sub> Applies			Shortest Optimum Nominal Length To Which Column T <sub>S</sub> Applies			
	Diameter		Length		Cup and Flat Points	90° Cone and Oval Points	Half Dog Points	Cup and Flat Points	90° Cone and Oval Points	Half Dog Point	
	Max	Min	Max	Min							
0	0.0600	0.040	0.037	0.017	0.013	7/64	1/8	7/64	1/16	1/8	7/64
1	0.0730	0.049	0.045	0.021	0.017	1/8	9/64	1/8	3/32	9/64	1/8
2	0.0860	0.057	0.053	0.024	0.020	1/8	9/64	9/64	3/32	9/64	9/64
3	0.0990	0.066	0.062	0.027	0.023	9/64	5/32	5/32	3/32	5/32	5/32
4	0.1120	0.075	0.070	0.030	0.026	9/64	11/64	5/32	3/32	11/64	5/32
5	0.1250	0.083	0.078	0.033	0.027	3/16	3/16	11/64	1/8	3/16	11/64
6	0.1380	0.092	0.087	0.038	0.032	11/64	13/64	3/16	1/8	13/64	3/16
8	0.1640	0.109	0.103	0.043	0.037	3/16	7/32	13/64	3/16	7/32	13/64
10	0.1900	0.127	0.120	0.049	0.041	3/16	1/4	15/64	3/16	1/4	15/64
1/4	0.2500	0.156	0.149	0.067	0.059	1/4	5/16	19/64	1/4	5/16	19/64
5/16	0.3125	0.203	0.195	0.082	0.074	5/16	25/64	23/64	5/16	25/64	23/64
3/8	0.3750	0.250	0.241	0.099	0.089	3/8	7/16	7/16	3/8	7/16	7/16
7/16	0.4375	0.297	0.287	0.114	0.104	7/16	35/64	31/64	7/16	35/64	31/64
1/2	0.5000	0.344	0.334	0.130	0.120	1/2	39/64	35/64	1/2	39/64	35/64
5/8	0.6250	0.469	0.456	0.164	0.148	5/8	49/64	43/64	5/8	49/64	43/64
3/4	0.7500	0.562	0.549	0.196	0.180	3/4	29/32	51/64	3/4	29/32	51/64
7/8	0.8750	0.656	0.642	0.227	0.211	7/8	1 1/8	63/64	7/8	1 1/8	63/64
1	1.0000	0.750	0.734	0.260	0.240	1	1 17/64	1 1/8	...	...	...
1 1/8	1.1250	0.844	0.826	0.291	0.271	1 1/8	1 25/64	1 3/16	...	...	...
1 1/4	1.2500	0.938	0.920	0.323	0.303	1 1/4	1 1/2	1 5/16	...	...	...
1 3/8	1.3750	1.031	1.011	0.354	0.334	1 3/8	1 21/32	1 7/16	...	...	...
1 1/2	1.5000	1.125	1.105	0.385	0.365	1 1/2	1 51/64	1 9/16	...	...	...
1 3/4	1.7500	1.312	1.289	0.448	0.428	1 3/4	2 7/32	1 61/64	...	...	...
2	2.0000	1.500	1.474	0.510	0.490	2	2 25/64	2 5/64	...	...	...

Reprinted from The American Society of Mechanical Engineers—ANSI/ASME B18.3-1986 (R1993).



**APPENDIX P  
HEX NUT SPECIFICATIONS**

**TABLE 18 DIMENSIONS OF HEX NUTS AND HEX JAM NUTS**



Nominal Size or Basic Major Dia of Thread	F		G		H		H <sub>1</sub>		Hex Nuts Specified Proof Load		Jam Nuts All Strength Levels
	Width Across Flats		Width Across Corners		Thickness Hex Nuts		Thickness Hex Jam Nuts		Up to 150,000 psi	150,000 psi and Greater	
	Basic	Max	Min	Max	Basic	Max	Min	Max	Basic	Max	Runout of Bearing Face, FIR Max
1/4	7/16	0.438	0.428	0.505	7/32	0.226	0.212	5/32	0.163	0.150	0.015
5/16	1/2	0.500	0.489	0.577	17/64	0.273	0.258	3/16	0.195	0.180	0.016
3/8	9/16	0.562	0.551	0.650	21/64	0.337	0.320	7/32	0.227	0.210	0.017
7/16	1 1/16	0.688	0.675	0.794	3/8	0.385	0.365	1/4	0.260	0.240	0.018
1/2	3/4	0.750	0.736	0.866	7/16	0.448	0.427	5/16	0.323	0.302	0.019
9/16	7/8	0.875	0.861	1.010	31/64	0.496	0.473	5/16	0.324	0.301	0.020
5/8	1 5/16	0.938	0.922	1.083	35/64	0.559	0.535	3/8	0.387	0.363	0.021
3/4	1 7/8	1.125	1.088	1.299	41/64	0.665	0.617	27/64	0.446	0.398	0.023
7/8	1 11/16	1.312	1.269	1.516	3/4	0.776	0.724	31/64	0.510	0.458	0.025
1	1 1/2	1.500	1.450	1.732	55/64	0.887	0.831	35/64	0.575	0.519	0.027
1 1/8	1 11/16	1.688	1.631	1.949	31/32	0.999	0.939	39/64	0.639	0.579	0.030
1 1/4	1 7/8	1.875	1.812	2.165	1 1/16	1.094	1.030	23/32	0.751	0.687	0.033
1 3/8	2 1/16	2.062	1.994	2.382	1 11/64	1.206	1.138	25/32	0.815	0.747	0.036
1 1/2	2 1/4	2.250	2.175	2.598	1 9/32	1.317	1.245	27/32	0.880	0.808	0.039

Reprinted from The American Society of Mechanical Engineers—ANSI B18.2.1-1987 (R1993).

**APPENDIX Q**  
**KEY AND KEYSEAT SPECIFICATIONS**

**TABLE 19 WOODRUFF KEY DIMENSIONS**



Key No.	Nominal Key Size W × B	Actual Length F +0.000-0.010	Height of Key				Distance Below Center E
			C		D		
			Max	Min	Max	Min	
202	1/16 × 1/4	0.248	0.109	0.104	0.109	0.104	1/64
202.5	1/16 × 5/16	0.311	0.140	0.135	0.140	0.135	1/64
302.5	3/32 × 5/16	0.311	0.140	0.135	0.140	0.135	1/64
203	1/16 × 3/8	0.374	0.172	0.167	0.172	0.167	1/64
303	3/32 × 3/8	0.374	0.172	0.167	0.172	0.167	1/64
403	1/8 × 3/8	0.374	0.172	0.167	0.172	0.167	1/64
204	1/16 × 1/2	0.491	0.203	0.198	0.194	0.188	3/64
304	3/32 × 1/2	0.491	0.203	0.198	0.194	0.188	3/64
404	1/8 × 1/2	0.491	0.203	0.198	0.194	0.188	3/64
305	3/32 × 5/8	0.612	0.250	0.245	0.240	0.234	1/16
405	1/8 × 5/8	0.612	0.250	0.245	0.240	0.234	1/16
505	5/32 × 5/8	0.612	0.250	0.245	0.240	0.234	1/16
605	3/16 × 5/8	0.612	0.250	0.245	0.240	0.234	1/16
406	1/8 × 3/4	0.740	0.313	0.308	0.303	0.297	1/16
506	3/32 × 3/4	0.740	0.313	0.308	0.303	0.297	1/16
606	3/16 × 3/4	0.740	0.313	0.308	0.303	0.297	1/16
806	1/4 × 3/4	0.740	0.313	0.308	0.303	0.297	1/16
507	5/32 × 7/8	0.866	0.375	0.370	0.365	0.359	1/16
607	3/16 × 7/8	0.866	0.375	0.370	0.365	0.359	1/16
707	7/32 × 7/8	0.866	0.375	0.370	0.365	0.359	1/16
807	1/4 × 7/8	0.866	0.375	0.370	0.365	0.359	1/16
608	3/16 × 1	0.992	0.438	0.433	0.428	0.422	1/16
708	7/32 × 1	0.992	0.438	0.433	0.428	0.422	1/16
808	1/4 × 1	0.992	0.438	0.433	0.428	0.422	1/16
1008	5/16 × 1	0.992	0.438	0.433	0.428	0.422	1/16
1208	3/8 × 1	0.992	0.438	0.433	0.428	0.422	1/16
609	3/16 × 1 1/8	1.114	0.484	0.479	0.475	0.469	5/64
709	7/32 × 1 1/8	1.114	0.484	0.479	0.475	0.469	5/64
809	1/4 × 1 1/8	1.114	0.484	0.479	0.475	0.469	5/64
1009	5/16 × 1 1/8	1.114	0.484	0.479	0.475	0.469	5/64
610	3/16 × 1 1/4	1.240	0.547	0.542	0.537	0.531	5/64
710	7/32 × 1 1/4	1.240	0.547	0.542	0.537	0.531	5/64
810	1/4 × 1 1/4	1.240	0.547	0.542	0.537	0.531	5/64
1010	5/16 × 1 1/4	1.240	0.547	0.542	0.537	0.531	5/64
1210	3/8 × 1 1/4	1.240	0.547	0.542	0.537	0.531	5/64
811	1/4 × 1 3/8	1.362	0.594	0.589	0.584	0.578	3/32
1011	5/16 × 1 3/8	1.362	0.594	0.589	0.584	0.578	3/32
1211	3/8 × 1 3/8	1.362	0.594	0.589	0.584	0.578	3/32
812	1/4 × 1 1/2	1.484	0.641	0.636	0.631	0.625	7/64
1012	5/16 × 1 1/2	1.484	0.641	0.636	0.631	0.625	7/64
1212	3/8 × 1 1/2	1.484	0.641	0.636	0.631	0.625	7/64

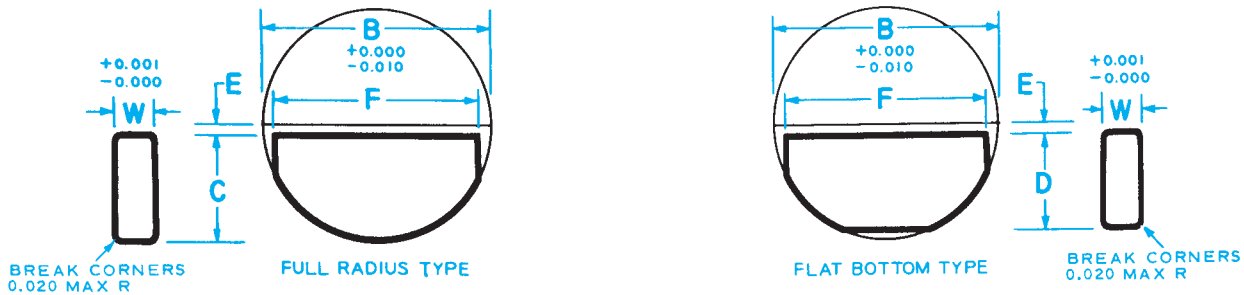
All dimensions given are in inches.

The key numbers indicate nominal key dimensions. The last two digits give the nominal diameter B in eighths of an inch and the digits preceding the last two give the nominal width W in thirty-seconds of an inch.

Example: No. 204 indicates a key 3/32 × 1/8 or 1/16 × 1/2.  
 No. 808 indicates a key 7/32 × 7/8 or 1/4 × 1.  
 No. 1212 indicates a key 12/32 × 1 1/2 or 3/8 × 1 1/2.

APPENDIX Q (Continued)

TABLE 19 (CONTINUED)—WOODRUFF KEY DIMENSIONS



Key No.	Nominal Key Size W B		Actual Length F +0.000-0.010	Height of Key				Distance Below Center E
				C		D		
				Max	Min	Max	Min	
617-1	3/16	2 1/8	1.380	0.406	0.401	0.396	0.390	21/32
817-1	1/4	2 1/8	1.380	0.406	0.401	0.396	0.390	21/32
1017-1	5/16	2 1/8	1.380	0.406	0.401	0.396	0.390	21/32
1217-1	3/8	2 1/8	1.380	0.406	0.401	0.396	0.390	21/32
617	3/16	2 1/8	1.723	0.531	0.526	0.521	0.515	17/32
817	1/4	2 1/8	1.723	0.531	0.526	0.521	0.515	17/32
1017	5/16	2 1/8	1.723	0.531	0.526	0.521	0.515	17/32
1217	3/8	2 1/8	1.723	0.531	0.526	0.521	0.515	17/32
822-1	1/4	2 3/4	2.000	0.594	0.589	0.584	0.578	25/32
1022-1	5/16	2 3/4	2.000	0.594	0.589	0.584	0.578	25/32
1222-1	3/8	2 3/4	2.000	0.594	0.589	0.584	0.578	25/32
1422-1	7/16	2 3/4	2.000	0.594	0.589	0.584	0.578	25/32
1622-1	1/2	2 3/4	2.000	0.594	0.589	0.584	0.578	25/32
822	1/4	2 3/4	2.317	0.750	0.745	0.740	0.734	5/8
1022	5/16	2 3/4	2.317	0.750	0.745	0.740	0.734	5/8
1222	3/8	2 3/4	2.317	0.750	0.745	0.740	0.734	5/8
1422	7/16	2 3/4	2.317	0.750	0.745	0.740	0.734	5/8
1622	1/2	2 3/4	2.317	0.750	0.745	0.740	0.734	5/8
1228	3/8	3 1/2	2.880	0.938	0.933	0.928	0.922	13/16
1428	7/16	3 1/2	2.880	0.938	0.933	0.928	0.922	13/16
1628	1/2	3 1/2	2.880	0.938	0.933	0.928	0.922	13/16
1828	9/16	3 1/2	2.880	0.938	0.933	0.928	0.922	13/16
2028	5/8	3 1/2	2.880	0.938	0.933	0.928	0.922	13/16
2228	11/16	3 1/2	2.880	0.938	0.933	0.928	0.922	13/16
2428	3/4	3 1/2	2.880	0.938	0.933	0.928	0.922	13/16

All dimensions given are in inches.

The key numbers indicate nominal key dimensions. The last two digits give the nominal diameter B in eighths of an inch and the digits preceding the last two give the nominal width W in thirty-seconds of an inch.

Example:

No. 617 indicates a key 6/32 17/8 or 3/16 2 1/8

No. 822 indicates a key 8/32 22/8 or 1/4 2 1/4

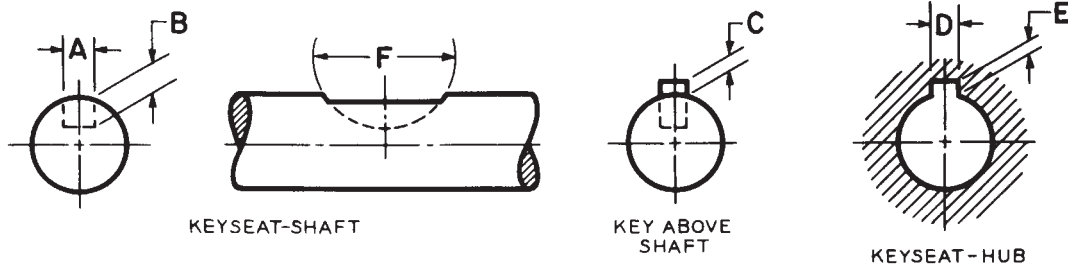
No. 1228 indicates a key 12/32 28/8 or 3/8 3 1/2

The key numbers with the -1 designation, while representing the nominal key size have a shorter length F and due to a greater distance below center E are less in height than the keys of the same number without the -1 designation.

Reprinted from The American Society of Mechanical Engineers—ANSI B17.2-1967 (R1990).

## APPENDIX Q (Continued)

TABLE 20 WOODRUFF KEYSEAT DIMENSIONS



Key Number	Nominal Size Key	Keyseat – Shaft					Key Above Shaft	Keyseat – Hub	
		Width A*		Depth B	Diameter F		Height C	Width D	Depth E
		Min	Max	+0.005 –0.000	Min	Max	+0.005 –0.005	+0.002 –0.000	+0.005 –0.000
202	$\frac{1}{6} \times \frac{1}{4}$	0.0615	0.0630	0.0728	0.250	0.268	0.0312	0.0635	0.0372
202.5	$\frac{1}{6} \times \frac{5}{16}$	0.0615	0.0630	0.1038	0.312	0.330	0.0312	0.0635	0.0372
302.5	$\frac{3}{32} \times \frac{5}{16}$	0.0928	0.0943	0.0882	0.312	0.330	0.0469	0.0948	0.0529
203	$\frac{1}{6} \times \frac{3}{8}$	0.0615	0.0630	0.1358	0.375	0.393	0.0312	0.0635	0.0372
303	$\frac{3}{32} \times \frac{3}{8}$	0.0928	0.0943	0.1202	0.375	0.393	0.0469	0.0948	0.0529
403	$\frac{1}{8} \times \frac{3}{8}$	0.1240	0.1255	0.1045	0.375	0.393	0.0625	0.1260	0.0685
204	$\frac{1}{6} \times \frac{1}{2}$	0.0615	0.0630	0.1668	0.500	0.518	0.0312	0.0635	0.0372
304	$\frac{3}{32} \times \frac{1}{2}$	0.0928	0.0943	0.1511	0.500	0.518	0.0469	0.0948	0.0529
404	$\frac{1}{8} \times \frac{1}{2}$	0.1240	0.1255	0.1355	0.500	0.518	0.0625	0.1260	0.0685
305	$\frac{3}{32} \times \frac{5}{8}$	0.0928	0.0943	0.1981	0.625	0.643	0.0469	0.0948	0.0529
405	$\frac{1}{8} \times \frac{5}{8}$	0.1240	0.1255	0.1825	0.625	0.643	0.0625	0.1260	0.0685
505	$\frac{5}{32} \times \frac{5}{8}$	0.1553	0.1568	0.1669	0.625	0.643	0.0781	0.1573	0.0841
605	$\frac{3}{16} \times \frac{5}{8}$	0.1863	0.1880	0.1513	0.625	0.643	0.0937	0.1885	0.0997
406	$\frac{1}{8} \times \frac{3}{4}$	0.1240	0.1255	0.2455	0.750	0.768	0.0625	0.1260	0.0685
506	$\frac{5}{32} \times \frac{3}{4}$	0.1553	0.1568	0.2299	0.750	0.768	0.0781	0.1573	0.0841
606	$\frac{3}{16} \times \frac{3}{4}$	0.1863	0.1880	0.2143	0.750	0.768	0.0937	0.1885	0.0997
806	$\frac{1}{4} \times \frac{3}{4}$	0.2487	0.2505	0.1830	0.750	0.768	0.1250	0.2510	0.1310
507	$\frac{5}{32} \times \frac{7}{8}$	0.1553	0.1568	0.2919	0.875	0.895	0.0781	0.1573	0.0841
607	$\frac{3}{16} \times \frac{7}{8}$	0.1863	0.1880	0.2763	0.875	0.895	0.0937	0.1885	0.0997
707	$\frac{7}{32} \times \frac{7}{8}$	0.2175	0.2193	0.2607	0.875	0.895	0.1093	0.2198	0.1153
807	$\frac{1}{4} \times \frac{7}{8}$	0.2487	0.2505	0.2450	0.875	0.895	0.1250	0.2510	0.1310
608	$\frac{3}{16} \times 1$	0.1863	0.1880	0.3393	1.000	1.020	0.0937	0.1885	0.0997
708	$\frac{7}{32} \times 1$	0.2175	0.2193	0.3237	1.000	1.020	0.1093	0.2198	0.1153
808	$\frac{1}{4} \times 1$	0.2487	0.2505	0.3080	1.000	1.020	0.1250	0.2510	0.1310
1008	$\frac{5}{16} \times 1$	0.3111	0.3130	0.2768	1.000	1.020	0.1562	0.3135	0.1622
1208	$\frac{3}{8} \times 1$	0.3735	0.3755	0.2455	1.000	1.020	0.1875	0.3760	0.1935
609	$\frac{3}{16} \times 1\frac{1}{8}$	0.1863	0.1880	0.3853	1.125	1.145	0.0937	0.1885	0.0997
709	$\frac{7}{32} \times 1\frac{1}{8}$	0.2175	0.2193	0.3697	1.125	1.145	0.1093	0.2198	0.1153
809	$\frac{1}{4} \times 1\frac{1}{8}$	0.2487	0.2505	0.3540	1.125	1.145	0.1250	0.2510	0.1310
1009	$\frac{5}{16} \times 1\frac{1}{8}$	0.3111	0.3130	0.3228	1.125	1.145	0.1562	0.3135	0.1622

APPENDIX Q (Continued)

TABLE 20 (CONTINUED)—WOODRUFF KEYSEAT DIMENSIONS

Key Number	Nominal Size Key	Keyseat – Shaft					Key Above Shaft	Keyseat – Hub	
		Width A*		Depth B	Diameter F		Height C	Width D	Depth E
		Min	Max	+0.005 –0.000	Min	Max	+0.005 –0.005	+0.002 –0.000	+0.005 –0.000
610	$\frac{3}{16} \times 1\frac{1}{4}$	0.1863	0.1880	0.4483	1.250	1.273	0.0937	0.1885	0.0997
710	$\frac{7}{32} \times 1\frac{1}{4}$	0.2175	0.2193	0.4327	1.250	1.273	0.1093	0.2198	0.1153
810	$\frac{1}{4} \times 1\frac{1}{4}$	0.2487	0.2505	0.4170	1.250	1.273	0.1250	0.2510	0.1310
1010	$\frac{5}{16} \times 1\frac{1}{4}$	0.3111	0.3130	0.3858	1.250	1.273	0.1562	0.3135	0.1622
1210	$\frac{3}{8} \times 1\frac{1}{4}$	0.3735	0.3755	0.3545	1.250	1.273	0.1875	0.3760	0.1935
811	$\frac{1}{4} \times 1\frac{3}{8}$	0.2487	0.2505	0.4640	1.375	1.398	0.1250	0.2510	0.1310
1011	$\frac{5}{16} \times 1\frac{3}{8}$	0.3111	0.3130	0.4328	1.375	1.398	0.1562	0.3135	0.1622
1211	$\frac{3}{8} \times 1\frac{3}{8}$	0.3735	0.3755	0.4015	1.375	1.398	0.1875	0.3760	0.1935
812	$\frac{1}{4} \times 1\frac{1}{2}$	0.2487	0.2505	0.5110	1.500	1.523	0.1250	0.2510	0.1310
1012	$\frac{5}{16} \times 1\frac{1}{2}$	0.3111	0.3130	0.4798	1.500	1.523	0.1562	0.3135	0.1622
1212	$\frac{3}{8} \times 1\frac{1}{2}$	0.3735	0.3755	0.4485	1.500	1.523	0.1875	0.3760	0.1935
617-1	$\frac{3}{16} \times 2\frac{1}{8}$	0.1863	0.1880	0.3073	2.125	2.160	0.0937	0.1885	0.0997
817-1	$\frac{1}{4} \times 2\frac{1}{8}$	0.2487	0.2505	0.2760	2.125	2.160	0.1250	0.2510	0.1310
1017-1	$\frac{5}{16} \times 2\frac{1}{8}$	0.3111	0.3130	0.2448	2.125	2.160	0.1562	0.3135	0.1622
1217-1	$\frac{3}{8} \times 2\frac{1}{8}$	0.3735	0.3755	0.2135	2.125	2.160	0.1875	0.3760	0.1935
617	$\frac{3}{16} \times 2\frac{1}{8}$	0.1863	0.1880	0.4323	2.125	2.160	0.0937	0.1885	0.0997
817	$\frac{1}{4} \times 2\frac{1}{8}$	0.2487	0.2505	0.4010	2.125	2.160	0.1250	0.2510	0.1310
1017	$\frac{5}{16} \times 2\frac{1}{8}$	0.3111	0.3130	0.3698	2.125	2.160	0.1562	0.3135	0.1622
1217	$\frac{3}{8} \times 2\frac{1}{8}$	0.3735	0.3755	0.3385	2.125	2.160	0.1875	0.3760	0.1935
822-1	$\frac{1}{4} \times 2\frac{3}{4}$	0.2487	0.2505	0.4640	2.750	2.785	0.1250	0.2510	0.1310
1022-1	$\frac{5}{16} \times 2\frac{3}{4}$	0.3111	0.3130	0.4328	2.750	2.785	0.1562	0.3135	0.1622
1222-1	$\frac{3}{8} \times 2\frac{3}{4}$	0.3735	0.3755	0.4015	2.750	2.785	0.1875	0.3760	0.1935
1422-1	$\frac{7}{16} \times 2\frac{3}{4}$	0.4360	0.4380	0.3703	2.750	2.785	0.2187	0.4385	0.2247
1622-1	$\frac{1}{2} \times 2\frac{3}{4}$	0.4985	0.5005	0.3390	2.750	2.785	0.2500	0.5010	0.2560
822	$\frac{1}{4} \times 2\frac{3}{4}$	0.2487	0.2505	0.6200	2.750	2.785	0.1250	0.2510	0.1310
1022	$\frac{5}{16} \times 2\frac{3}{4}$	0.3111	0.3130	0.5888	2.750	2.785	0.1562	0.3135	0.1622
1222	$\frac{3}{8} \times 2\frac{3}{4}$	0.3735	0.3755	0.5575	2.750	2.785	0.1875	0.3760	0.1935
1422	$\frac{7}{16} \times 2\frac{3}{4}$	0.4360	0.4380	0.5263	2.750	2.785	0.2187	0.4385	0.2247
1622	$\frac{1}{2} \times 2\frac{3}{4}$	0.4985	0.5005	0.4950	2.750	2.785	0.2500	0.5010	0.2560
1228	$\frac{3}{8} \times 3\frac{1}{2}$	0.3735	0.3755	0.7455	3.500	3.535	0.1875	0.3760	0.1935
1428	$\frac{7}{16} \times 3\frac{1}{2}$	0.4360	0.4380	0.7143	3.500	3.535	0.2187	0.4385	0.2247
1628	$\frac{1}{2} \times 3\frac{1}{2}$	0.4985	0.5005	0.6830	3.500	3.535	0.2500	0.5010	0.2560
1828	$\frac{5}{16} \times 3\frac{1}{2}$	0.5610	0.5630	0.6518	3.500	3.535	0.2812	0.5635	0.2872
2028	$\frac{3}{8} \times 3\frac{1}{2}$	0.6235	0.6255	0.6205	3.500	3.535	0.3125	0.6260	0.3185
2228	$1\frac{1}{16} \times 3\frac{1}{2}$	0.6860	0.6880	0.5893	3.500	3.535	0.3437	0.6885	0.3497
2428	$\frac{3}{4} \times 3\frac{1}{2}$	0.7485	0.7505	0.5580	3.500	3.535	0.3750	0.7510	0.3810

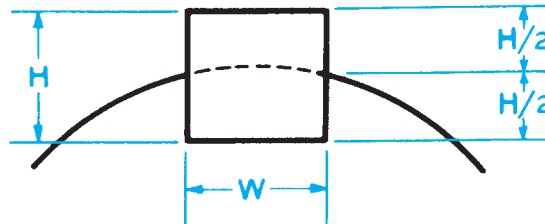
\*Width A values were set with the maximum keyseat (shaft) width as that figure which will receive a key with the greatest amount of looseness consistent with assuring the key's sticking in the keyseat (shaft). Minimum keyseat width is that figure permitting the largest shaft distortion acceptable when assembling maximum key in minimum keyseat.

Dimensions A, B, C, D are taken at side intersection.

Reprinted from The American Society of Mechanical Engineers—ANSI B17.2-1967 (R1990).

## APPENDIX Q (Continued)

TABLE 21 KEY SIZE VERSUS SHAFT DIAMETER



Nominal Shaft Diameter		Nominal Key Size			Nominal Keyseat Depth		
Over	To (Incl)	Width, W	Height, H		H/2		
			Square	Rectangular	Square	Rectangular	
5/16	7/16	3/32	3/32			3/64	
7/16	9/16	1/8	1/8		3/32	1/16	3/64
9/16	7/8	3/16	3/16		1/8	3/32	1/16
7/8	1-1/4	1/4	1/4		3/16	1/8	3/32
1-1/4	1-3/8	5/16	5/16		1/4	5/32	1/8
1-3/8	1-3/4	3/8	3/8		1/4	3/16	1/8
1-3/4	2-1/4	1/2	1/2		3/8	1/4	3/16
2-1/4	2-3/4	5/8	5/8		7/16	5/16	7/32
2-3/4	3-1/4	3/4	3/4		1/2	3/8	1/4
3-1/4	3-3/4	7/8	7/8		5/8	7/16	5/16
3-3/4	4-1/2	1	1		3/4	1/2	3/8
4-1/2	5-1/2	1-1/4	1-1/4		7/8	5/8	7/16
5-1/2	6-1/2	1-1/2	1-1/2		1	3/4	1/2
6-1/2	7-1/2	1-3/4	1-3/4		1-1/2*	7/8	3/4
7-1/2	9	2	2		1-1/2	1	3/4
9	11	2-1/2	2-1/2		1-3/4	1-1/4	7/8
11	13	3	3		2	1-1/2	1
13	15	3-1/2	3-1/2		2-1/2	1-3/4	1-1/4
15	18	4			3		1-1/2
18	22	5			3-1/2		1-3/4
22	26	6			4		2
26	30	7			5		2-1/2

\*Some key standards show 1-1/4 in. Preferred size is 1-1/2 in. All dimensions given in inches.

Shaded areas:

For a stepped shaft, the size of a key is determined by the diameter of the shaft at the point of location of the key, regardless of the number of different diameters on the shaft.

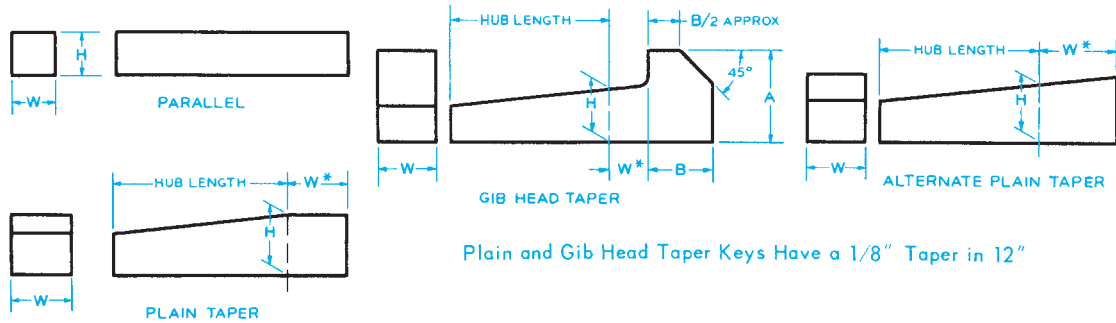
Square-keys are preferred through 6 1/2-in. diameter shafts and rectangular keys for larger shafts. Sizes and dimensions in unshaded area are preferred.

If special considerations dictate the use of a keyseat in the hub shallower than the preferred nominal depth shown in Table 1, it is recommended that the tabulated preferred nominal standard keyseat be used in the shaft in all cases.

Reprinted from The American Society of Mechanical Engineers—ANSI B17.1-1967 (R1989).

APPENDIX Q (Continued)

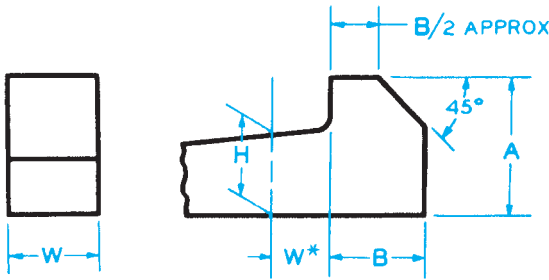
TABLE 22 KEY DIMENSIONS AND TOLERANCES



Key	Nominal Key Size		Tolerance					
	Width, W		Width, W		Height, H			
	Over	To (Incl)						
Parallel	Square	Bar Stock	—	3/4	+0.000	-0.002	+0.000	-0.002
			3/4	1-1/2	+0.000	-0.003	+0.000	-0.003
			1-1/2	2-1/2	+0.000	-0.004	+0.000	-0.004
			2-1/2	3-1/2	+0.000	-0.006	+0.000	-0.006
			3-1/2	4-1/2	+0.000	-0.008	+0.000	-0.008
	Rectangular	Bar Stock	—	3/4	+0.000	-0.003	+0.000	-0.003
			3/4	1-1/2	+0.000	-0.004	+0.000	-0.004
			1-1/2	3	+0.000	-0.005	+0.000	-0.005
			3	4	+0.000	-0.006	+0.000	-0.006
			4	6	+0.000	-0.008	+0.000	-0.008
Taper	Plain or Gib Head Square or Rectangle	—	1-1/4	+0.001	-0.000	+0.005	-0.000	
		1-1/4	3	+0.002	-0.000	+0.005	-0.000	
		3	7	+0.003	-0.000	+0.005	-0.000	
		7	15	+0.004	-0.000	+0.005	-0.000	
		15	30	+0.005	-0.000	+0.005	-0.000	

\*For locating position of dimension H. Tolerance does not apply. All dimensions given in inches.  
 Reprinted from The American Society of Mechanical Engineers—ANSI B17.1-1967 (R1989).

TABLE 23 GIB HEAD NOMINAL DIMENSIONS



Nominal Key Size Width, W	Square			Rectangular		
	H	A	B	H	A	B
1/8	1/8	1/4	1/4	3/32	3/16	1/8
3/16	3/16	5/16	5/16	1/8	1/4	1/4
1/4	1/4	7/16	3/8	3/16	5/16	5/16
5/16	5/16	1/2	7/16	1/4	7/16	3/8
3/8	3/8	5/8	1/2	1/4	7/16	3/8
1/2	1/2	7/8	5/8	3/8	5/8	1/2
5/8	5/8	1	3/4	7/16	3/4	9/16
3/4	3/4	1-1/4	7/8	1/2	7/8	5/8
7/8	7/8	1-3/8	1	5/8	1	3/4
1	1	1-5/8	1-1/8	3/4	1-1/4	7/8
1-1/4	1-1/4	2	1-7/16	7/8	1-3/8	1
1-1/2	1-1/2	2-3/8	1-3/4	1	1-5/8	1-1/8
1-3/4	1-3/4	2-3/4	2	1-1/2	2-3/8	1-3/4
2	2	3-1/2	2-1/4	1-1/2	2-3/8	1-3/4
2-1/2	2-1/2	4	3	1-3/4	2-3/4	2
3	3	5	3-1/2	2	3-1/2	2-1/4
3-1/2	3-1/2	6	4	2-1/2	4	3

\*For locating position of dimension H.  
 For larger sizes the following relationships are suggested as guides for establishing A and B.

$$A = 1.8 H \quad B = 1.2 H$$

All dimensions given in inches.

Reprinted from The American Society of Mechanical Engineers—ANSI B17.1-1967 (R1989).

## APPENDIX Q (Continued)

TABLE 24 CLASS 2 FIT FOR PARALLEL AND TAPER KEYS									
Type of Key	Key Width		Side Fit			Top and Bottom Fit			
	Over	To (Incl)	Width Tolerance		Fit Range*	Depth Tolerance			Fit Range*
			Key	Keyset		Key	Shaft Keyseat	Hub Keyseat	
Parallel Square	—	1-1/4	+0.001 -0.000	+0.002 -0.000	0.002 CL 0.001 INT	+0.001 -0.000	+0.000 -0.015	+0.010 -0.000	0.030 CL 0.004 CL
	1-1/4	3	+0.002 -0.000	+0.002 -0.000	0.002 CL 0.002 INT	+0.002 -0.000	+0.000 -0.015	+0.010 -0.000	0.030 CL 0.003 CL
	3	3-1/2	+0.003 -0.000	+0.002 -0.000	0.002 CL 0.003 INT	+0.003 -0.000	+0.000 -0.015	+0.010 -0.000	0.030 CL 0.002 CL
Parallel Rectangular	—	1-1/4	+0.001 -0.000	+0.002 -0.000	0.002 CL 0.001 INT	+0.005 -0.005	+0.000 -0.015	+0.010 -0.000	0.035 CL 0.000 CL
	1-1/4	3	+0.002 -0.000	+0.002 -0.000	0.002 CL 0.002 INT	+0.005 -0.005	+0.000 -0.015	+0.010 -0.000	0.035 CL 0.000 CL
	3	7	+0.003 -0.000	+0.002 -0.000	0.002 CL 0.003 INT	+0.005 -0.005	+0.000 -0.015	+0.010 -0.000	0.035 CL 0.000 CL
Taper	—	1-1/4	+0.001 -0.000	+0.002 -0.000	0.002 CL 0.001 INT	+0.005 -0.000	+0.000 -0.015	+0.010 -0.000	0.005 CL 0.025 INT
	1-1/4	3	+0.002 -0.000	+0.002 -0.000	0.002 CL 0.002 INT	+0.005 -0.000	+0.000 -0.015	+0.010 -0.000	0.005 CL 0.025 INT
	3	Δ	+0.003 -0.000	+0.002 -0.000	0.002 CL 0.003 INT	+0.005 -0.000	+0.000 -0.015	+0.010 -0.000	0.005 CL 0.025 INT

\*Limits of variation. CL = Clearance; INT = Interference

Δ To (Incl) 3-1/2 Square and 7 Rectangular key widths.

All dimensions given in inches.

Reprinted from The American Society of Mechanical Engineers—ANSI B17.1-1967 (R1989).



**APPENDIX R**  
**TAP DRILL SIZES**

**TABLE 25 DECIMAL EQUIVALENTS AND TAP DRILL SIZES  
(LETTER AND NUMBER DRILL SIZES)**

Fraction or Drill Size	Decimal Equivalent	Tap Size	Fraction or Drill Size	Decimal Equivalent	Tap Size	Fraction or Drill Size	Decimal Equivalent	Tap Size	Fraction or Drill Size	Decimal Equivalent	Tap Size																					
$\frac{1}{64}$	Number Size Drills 80	.0135	$\frac{7}{64}$	39	.0995	$\frac{15}{64}$	Letter Size Drills B C D E F G	2344	$\frac{19}{64}$	$\frac{39}{64}$	11/16-11																					
	79	.0145		38	.1015			2380				5/16-18	5/8	.5938																		
	78	.0156		37	.1040			2420				5/16-24	8	.6094																		
	77	.0160		36	.1065			2460					11/16-16	21/32	.6250																	
	76	.0180		35	.1094			2500					3/4-10	43/32	.6406																	
	75	.0200		34	.1100			2570					3/4-16	64	.6562																	
	74	.0210		33	.1110			2610						11/16	45/64	.6719																
	73	.0225		32	.1120			2656						7/8-9	23/32	.6875																
	72	.0240		31	.1130			2660							7/8	47/32	.7031															
	71	.0250		30	.1150			2720							7/8-14	32	.7188															
70	.0260	29	.1160	2770	3/4	64	.7344																									
69	.0280	28	.1185	2810	1-8	7/8	.7500																									
68	.0292	27	.1200	2856		7/8	49/64	.7656																								
$\frac{1}{32}$	67	.0310	$\frac{9}{64}$	26		.1405	$\frac{9}{32}$	L M N O P	2812	$\frac{51}{64}$	$\frac{25}{32}$	7/8-14																				
	66	.0312		25		.1406			2900							3/8-16	13/16	.7812														
	65	.0320		24		.1440			2950				3/8-24			16	.7969															
	64	.0330		23		.1470			2969							13/16	53/64	.8125														
	63	.0332		22		.1495			3020					1-8		27/32	.8281															
	62	.0350		21		.1520			3125							3/8	64	.8438														
	61	.0360		20		.1540			3160						1-8	32	.8594															
	60	.0370		19		.1562			3230							7/8	55/32	.8750														
	59	.0380		18	.1570	3260			1-12, 14							8	.8906															
	58	.0390		17	.1575	3281										29/32	64	.8962														
57	.0400	16	.1590	3320	3/8-24	15/16	59/32	.9219																								
56	.0410	15	.1610	3390		15/16	64	.9375																								
$\frac{3}{64}$	55	.0420	$\frac{11}{64}$	14		.1660	$\frac{11}{32}$	Q R S T U V W		3438	$\frac{61}{64}$	$\frac{31}{32}$	1-12, 14																			
	54	.0430		13		.1695				3480						3/8-16	31/32	.9531														
	53	.0465		12		.1719				3580				7/16-14		1	.9688															
	52	.0469		11		.1730				3594						1	63/32	.9844														
	51	.0520		10		.1770				3680					7/16-20	1	64	1.0000														
	50	.0550		9		.1820				3750						3/8	1	1.0469														
	49	.0595		8		.1850			3770	7/16-20						1 1/8	17/64	1.1094														
	48	.0625		7		.1875			3860							1 1/8	1 1/8	1.1250														
	$\frac{5}{64}$	47		.0635	$\frac{3}{16}$	6			.1890							$\frac{25}{64}$	X Y Z	3906	$\frac{111}{64}$	$\frac{17}{32}$	1 1/4-12											
		46		.0670		5			.1910									3970				1 1/4	1 1/4	1.1719								
45		.0700	4	.1935		4040	7/16-20	1 1/4	17/32		1.2188																					
44		.0730	3	.1960		4062		1 1/4	1 1/4		1.2500																					
43		.0770	2	.1990		4130		1 1/2-13	1 1/4		1 19/64	1.2969																				
42		.0781	1	.2010		4219			1 1/2-13		1 1/2	1 11/32	1.3438																			
$\frac{3}{32}$		41	.0785	$\frac{13}{64}$		10					.2040	$\frac{13}{32}$	Z	4375	$\frac{119}{64}$			$\frac{11}{32}$				1 1/2-12										
		40	.0810			9					.2055			4421									1 1/2	1 3/8	1.3750							
		$\frac{1}{16}$	39			.0820				$\frac{7}{32}$	8			.2090									$\frac{27}{64}$	Z	4531	$\frac{127}{64}$	$\frac{11}{2}$	1 1/2-12				
			38			.0860					7			.2130											4688				1 1/2-20	1 1/2	1.4219	
	37		.0890		6	.2188					4775			1 1/2-20		1 1/2	1.4719															
	36		.0935		5	.2210					4844					9/16-12	1 1/2		1.5000													
	$\frac{1}{8}$		35		.0938	Letter Size Drills A	4				.2280						$\frac{29}{64}$		Z	4844	$\frac{31}{64}$				$\frac{15}{32}$					9/16-12		
			34		.0960		3				.2340									5000											9/16-18	1 1/2
			33		.0980		2	.2340			5156									5/8-11												1 1/2
			$\frac{1}{4}$		32		.1015	Letter Size Drills A	1		.2280																					5312
31				.1040	1		.2280		5469		5/8-11	1 1/2	1.5000																			
30				.1065	1		.2280		5625			5/8-18	1 1/2		1.5000																	
29		.1094		1	.2280		5781		5/8-18	1 1/2			1.5000																			
28		.1100		1	.2280		5781			5/8-18			1 1/2		1.5000																	
27		.1110		1	.2280		5781						5/8-18	1 1/2	1.5000																	
26		.1130		1	.2280		5781							5/8-18	1 1/2	1.5000																
25	.1160	1		.2280	5781	5/8-18	1 1/2								1.5000																	
24	.1185	1		.2280	5781		5/8-18								1 1/2	1.5000																
23	.1200	1		.2280	5781										5/8-18	1 1/2	1.5000															
22	.1250	1	.2280	5781	5/8-18			1 1/2								1.5000																
21	.1285	1	.2280	5781				5/8-18			1 1/2					1.5000																
20	.1360	1	.2280	5781							5/8-18	1 1/2				1.5000																
19	.1405	1	.2280	5781					5/8-18			1 1/2				1.5000																
18	.1406	1	.2280	5781						5/8-18		1 1/2				1.5000																
17	.1440	1	.2280	5781								5/8-18	1 1/2			1.5000																
16	.1470	1	.2280	5781									5/8-18	1 1/2		1.5000																
15	.1495	1	.2280	5781		5/8-18								1 1/2		1.5000																
14	.1520	1	.2280	5781			5/8-18							1 1/2		1.5000																
13	.1540	1	.2280	5781										5/8-18	1 1/2	1.5000																
12	.1562	1	.2280	5781	5/8-18										1 1/2	1.5000																
11	.1570	1	.2280	5781				5/8-18							1 1/2	1.5000																
10	.1590	1	.2280	5781							5/8-18				1 1/2	1.5000																
9	.1610	1	.2280	5781					5/8-18						1 1/2	1.5000																
8	.1660	1	.2280	5781						5/8-18					1 1/2	1.5000																
7	.1695	1	.2280	5781								5/8-18			1 1/2	1.5000																
6	.1719	1	.2280	5781									5/8-18		1 1/2	1.5000																
5	.1730	1	.2280	5781		5/8-18									1 1/2	1.5000																
4	.1770	1	.2280	5781			5/8-18								1 1/2	1.5000																
3	.1820	1	.2280	5781										5/8-18	1 1/2	1.5000																
2	.1850	1	.2280	5781	5/8-18										1 1/2	1.5000																
1	.1875	1	.2280	5781				5/8-18							1 1/2	1.5000																
0	.1890	1	.2280	5781							5/8-18				1 1/2	1.5000																
0	.1910	1	.2280	5781					5/8-18						1 1/2	1.5000																
0	.1935	1	.2280	5781						5/8-18					1 1/2	1.5000																
0	.1960	1	.2280	5781								5/8-18			1 1/2	1.5000																
0	.1990	1	.2280	5781									5/8-18		1 1/2	1.5000																
0	.2010	1	.2280	5781		5/8-18									1 1/2	1.5000																
0	.2040	1	.2280	5781			5/8-18								1 1/2	1.5000																
0	.2055	1	.2280	5781										5/8-18	1 1/2	1.5000																
0	.2090	1	.2280	5781	5/8-18										1 1/2	1.5000																
0	.2130	1	.2280	5781				5/8-18							1 1/2	1.5000																
0	.2188	1	.2280	5781							5/8-18				1 1/2	1.5000																
0	.2210	1	.2280	5781					5/8-18						1 1/2	1.5000																
0	.2280	1	.2280	5781						5/8-18					1 1/2	1.5000																
0	.2340	1	.2280	5781								5/8-18			1 1/2	1.5000																

Courtesy The L. S. Starrett Company, Athol, Massachusetts.

## APPENDIX S CONCRETE REINFORCING BAR (REBAR) SPECIFICATIONS

REINFORCING BAR SIZES			
US		Metric	
Size	Inch	Size	mm
#3	.375	#10	10
#4	.5	#13	13
#5	.625	#16	16
#6	.75	#19	19
#7	.875	#22	22
#8	1.0	#25	25
#9	1.125	#29	29
#10	1.25	#32	32
#11	1.375	#36	36
#14	1.75	#43	43
#18	2.25	#57	57

REINFORCING BAR GRADE			
Billet Steel			
Inch	Grade	Metric	Grade
#3–#6	40	#10–#19	300
#3–#18	60	#10–#57	420
#6–#18	75	#19–#57	520

SYMBOL FOR TYPE OF STEEL			
Symbol	Type	Grade	ASTM Standard
S	Billet steel	40–75	A615
		300–520	A615M
I	Rail steel	40–60	A616
		300–520	A996M
R	Rail steel	40–60	A616
A	Axle steel	40–60	A617
		300–420	A996M
W	Low alloy	60	A706
		420	A706M

American Society for Testing and Materials (ASTM) requires reinforcing bar identification letters and numbers on the rebar in this order:

- Mill letter or symbol
- Bar size
- Symbol for type of steel
- Grade number and lines

Grade, type, and class are terms used to classify steel products. Different steel grades have specific uses. *Grade* is used to indicate chemical composition. *Type* is used to specify deoxidation practice. *Class* is used to describe some other feature, such as strength level or surface smoothness.

Billet, rail, axle, and low alloy steel are types and classes of steel with different tensile and bending strength, deformation, and chemical composition specifications available from ASTM.

## APPENDIX T COMMON WELDED WIRE REINFORCEMENT SPECIFICATIONS

**TABLE 26 WIRE SIZE COMPARISON  
(WHEN CUSTOMARY UNITS ARE SPECIFIED)**

W & D Wire Size* Plain*	W & D Metric Wire Size (Conversion) Plain**	CUSTOMARY UNITS			METRIC UNITS (conversions)		
		Area (sq. in.)	Diameter (in.)	Nominal Weight (lb./ft.)	Nominal Area (mm <sup>2</sup> )	Nominal Diameter (mm)	Nominal Mass (kg/m)
W45	MW 290	.45	.757	1.530	290	19.23	2.28
W31	MW 200	.31	.628	1.054	200	15.96	1.57
W20	MW 130	.200	.505	.680	129	12.8	1.01
	MW 122	.189	.490	.643	122	12.4	0.96
W18	MW 116	.180	.479	.612	116	12.2	0.91
	MW 108	.168	.462	.571	108	11.7	0.85
W16	MW 103	.160	.451	.544	103	11.5	0.81
	MW 94	.146	.431	.495	94	10.9	0.74
W14	MW 90	.140	.422	.476	90	10.7	0.71
	MW 79	.122	.394	.414	79	10.0	0.62
W12	MW 77	.120	.391	.408	77	9.9	0.61
W11	MW 71	.110	.374	.374	71	9.5	0.56
W10.5	MW 68	.105	.366	.357	68	9.3	0.53
	MW 67	.103	.363	.351	67	9.2	0.52
W10	MW 65	.100	.357	.340	65	9.1	0.51
W9.5	MW 61	.095	.348	.323	61	8.8	0.48
W9	MW 58	.090	.338	.306	58	8.6	0.45
	MW 56	.086	.331	.292	55.5	8.4	0.43
W8.5	MW 55	.085	.329	.289	54.9	8.4	0.43
W8	MW 52	.080	.319	.272	52	8.1	0.40
W7.5	MW 48	.075	.309	.255	48.4	7.8	0.38
W7	MW 45	.070	.299	.238	45	7.6	0.35
W6.5	MW 42	.065	.288	.221	42	7.3	0.33
	MW 41	.063	.283	.214	41	7.2	0.32
W6	MW 39	.060	.276	.204	39	7.0	0.30
W5.5	MW 36	.055	.265	.187	35.5	6.7	0.28
	MW 35	.054	.263	.184	34.8	6.7	0.27
W5	MW 32	.050	.252	.170	32	6.4	0.25
	MW 30	.047	.244	.158	30	6.2	0.24
	MW 29	.045	.239	.153	29	6.1	0.23
W4	MW 26	.040	.226	.136	26	5.7	0.20
W3.5	MW 23	.035	.211	.119	23	5.4	0.18
W2.9	MW 19	.029	.192	.098	19	4.9	0.15
W2.0	MW 13	.020	.160	.068	13	4.1	0.10
W1.4	MW 9	.014	.135	.048	9	3.4	0.07

\* For deformed wire, change W to D. \*\* For deformed wire (metric) change MW to MD.

Provided Courtesy of Wire Reinforcement Institute, Copyright July 2001.

## APPENDIX T (Continued)

**TABLE 26 (CONTINUED)—WIRE SIZE COMPARISON  
(WHEN METRIC UNITS ARE SPECIFIED)**

Metric Units				Inch-pound Units (conversions)				Gage Guide
Size* (MW = Plain) (mm <sup>2</sup> )	Area (mm <sup>2</sup> )	Diameter (mm)	Mass (kg/m)	Nominal Size* (W = Plain) (in. <sup>2</sup> ×100)	Area (in. <sup>2</sup> )	Diameter (in.)	Weight (lb./ft.)	
MW290	290	19.23	2.28	W45	.450	.757	1.53	
MW200	200	15.96	1.57	W31	.310	.628	1.054	
MW130	130	12.9	1.02	W20.2	.202	.507	.687	
MW120	120	12.4	0.941	W18.6	.186	.487	.632	7/0
MW100	100	11.3	0.784	W15.5	.155	.444	.527	6/0
MW90	90	10.7	0.706	W14.0	.140	.422	.476	5/0
MW80	80	10.1	0.627	W12.4	.124	.397	.422	
MW70	70	9.4	0.549	W10.9	.109	.373	.371	4/0
MW65	65	9.1	0.510	W10.1	.101	.359	.343	3/0
MW60	60	8.7	0.470	W9.3	.093	.344	.316	
MW55	55	8.4	0.431	W8.5	.085	.329	.289	2/0
MW50	50	8.0	0.392	W7.8	.078	.314	.263	
MW45	45	7.6	0.353	W7.0	.070	.298	.238	1/0
MW40	40	7.1	0.314	W6.2	.062	.283	.214	1
MW35	35	6.7	0.274	W5.4	.054	.262	.184	2
MW30	30	6.2	0.235	W4.7	.047	.245	.160	3
MW26	26	5.7	0.204	W4.0	.040	.226	.136	4
MW25	25	5.6	0.196	W3.9	.039	.223	.133	
MW20	20	5.0	0.157	W3.1	.031	.199	.105	
MW19	19	4.9	0.149	W2.9	.029	.192	.098	6
MW15	15	4.4	0.118	W2.3	.023	.171	.078	
MW13	13	4.1	0.102	W2.0	.020	.160	.068	8
MW10	10	3.6	0.078	W1.6	.016	.143	.054	
MW9	9	3.4	0.071	W1.4	.014	.135	.048	10

\* Wires may be deformed, use prefix MD or D, except where only MW or W is required by building codes (usually less than MW26 or W4). For other available wire sizes, consult other WRI publications or discuss with WWR manufacturers.

APPENDIX T (Continued)

TABLE 27 COMMON STYLES OF METRIC WELDED WIRE REINFORCEMENT (WWR) WITH EQUIVALENT US CUSTOMARY UNITS <sup>3</sup>						
	A <sup>1</sup> (mm <sup>2</sup> /m)	Metric Styles (MW = Plain wire) <sup>2</sup>	Wt. (kg/m <sup>2</sup> )	Equivalent US Customary Style	A <sup>1</sup> (in. <sup>2</sup> /ft)	Wt (lbs/CSF)
A <sup>1 &amp; 4</sup>	88.9	102×102—MW9×MW9	1.51	4×4—W1.4×W1.4	.042	31
	127.0	102×102—MW13×MW13	2.15	4×4—W2.0×W2.0	.060	44
	184.2	102×102—MW19×MW19	3.03	4×4—W2.9×W2.9	.087	62
	254.0	102×102—MW26×MW26	4.30	4×4—W4.0×W4.0	.120	88
	59.3	152×152—MW9×MW9	1.03	6×6—W1.4×W1.4	.028	21
	84.7	152×152—MW13×MW13	1.46	6×6—W2.0×W2.0	.040	30
	122.8	152×152—MW19×MW19	2.05	6×6—W2.9×W2.9	.058	42
	169.4	152×152—MW26×MW26	2.83	6×6—W4.0×4.0	.080	58
B <sup>1</sup>	196.9	102×102—MW20×MW20	3.17	4×4—W3.1×W3.1	.093	65
	199.0	152×152—MW30×MW30	3.32	6×6—W4.7×W4.7	.094	68
	199.0	305×305—MW61×MW61	3.47	12×12—W9.4×W9.4	.094	71
	362.0	305×305—MW110×MW110	6.25	12×12—W17.1×W17.1	.171	128
C <sup>1</sup>	342.9	152×152—MW52×MW52	5.66	6×6—W8.1×W8.1	.162	116
	351.4	152×152—MW54×MW54	5.81	6×6—W8.3×W8.3	.166	119
	192.6	305×305—MW59×MW59	8.25	12×12—W9.1×W9.1	.091	69
	351.4	305×305—MW107×MW107	9.72	12×12—W16.6×W16.6	.166	125
D <sup>1</sup>	186.3	152×152—MW28×MW28	3.22	6×6—W4.4×W4.4	.088	63
	338.7	152×152—MW52×MW52	5.61	6×6—W8×W8	.160	115
	186.3	305×305—MW57×MW57	3.22	12×12—W8.8×W8.8	.088	66
	338.7	305×305—MW103×MW103	5.61	12×12—W16×W16	.160	120
E <sup>1</sup>	177.8	152×152—MW27×MW27	3.08	6×6—W4.2×W4.2	.084	60
	317.5	152×152—MW48×MW48	5.52	6×6—W7.5×W7.5	.150	108
	175.7	305×305—MW54×MW54	3.08	12×12—W8.3×W8.3	.083	63
	317.5	305×305—MW97×MW97	5.52	12×12—W15×W15	.150	113

<sup>1</sup>Group A—Compares areas of WWR at a minimum  $f_y = 65,000$  psi

Group B—Compares areas of WWR at a minimum  $f_y = 70,000$  psi

Group C—Compares areas of WWR at a minimum  $f_y = 72,000$  psi

Group D—Compares areas of WWR at a minimum  $f_y = 75,000$  psi

Group E—Compares areas of WWR at a minimum  $f_y = 80,000$  psi

} with areas of #3 or #4 rebar at 12" o.c. +  
at minimum  $f_y = 60,000$  psi

<sup>2</sup>Wires may also be deformed, use prefix MD or D, except where only MW or W is required by building codes (usually less than a MW26 or W4). Also wire sizes can be specified in 1 mm<sup>2</sup> (metric) or .001 in.<sup>2</sup> (US Customary) Increments.

<sup>3</sup>For other available styles or wire sizes, consult other WRI publications or discuss with WWR manufacturers.

<sup>4</sup>Styles may be obtained in roll form. Note: It is recommended that rolls be straightened and cut to size before placement.

APPENDIX U

ASTM A500 SQUARE AND RECTANGULAR STRUCTURAL TUBING SPECIFICATIONS											
Size	Wall (nominal)	Weight per Foot	Size	Wall (nominal)	Weight per Foot	Size	Wall (nominal)	Weight per Foot	Size	Wall (nominal)	Weight per Foot
2 1/2" x 2 1/2"	0.125	3.90	3" x 2"	0.125	3.90	6" x 4"	0.125	8.16	10" x 4"	0.188	17.08
2 1/2" x 2 1/2"	0.188	5.59	3" x 2"	0.188	5.59	6" x 4"	0.188	11.97	10" x 4"	0.250	22.42
2 1/2" x 2 1/2"	0.250	7.10	3" x 2"	0.250	7.10	6" x 4"	0.250	15.61	10" x 4"	0.313	27.58
3" x 3"	0.125	4.75	3 1/2" x 2 1/2"	0.125	4.75	6" x 4"	0.313	19.08	10" x 4"	0.375	32.57
3" x 3"	0.188	6.87	3 1/2" x 2 1/2"	0.188	6.87	6" x 4"	0.375	22.36	10" x 4"	0.500	42.03
3" x 3"	0.250	8.80	3 1/2" x 2 1/2"	0.250	8.80	6" x 4"	0.500	28.41	10" x 6"	0.188	19.63
3" x 3"	0.313	10.57	4" x 2"	0.125	4.75	6" x 5"	0.188	13.25	10" x 6"	0.250	25.82
3 1/2" x 3 1/2"	0.125	5.60	4" x 2"	0.188	6.87	6" x 5"	0.250	17.31	10" x 6"	0.313	31.84
3 1/2" x 3 1/2"	0.188	8.14	4" x 2"	0.250	8.80	6" x 5"	0.313	21.20	10" x 6"	0.375	37.68
3 1/2" x 3 1/2"	0.250	10.51	4" x 2"	0.313	10.57	6" x 5"	0.375	24.92	10" x 6"	0.500	48.83
3 1/2" x 3 1/2"	0.313	12.69	4" x 3"	0.125	5.60	7" x 3"	0.188	11.97	10" x 8"	0.250	29.22
3 1/2" x 3 1/2"	0.375	14.71	4" x 3"	0.188	8.14	7" x 3"	0.250	15.61	10" x 8"	0.313	36.09
4" x 4"	0.125	6.46	4" x 3"	0.250	10.51	7" x 3"	0.313	19.08	10" x 8"	0.375	42.78
4" x 4"	0.188	9.42	4" x 3"	0.313	12.69	7" x 3"	0.375	22.36	10" x 8"	0.500	55.64
4" x 4"	0.250	12.21	4" x 3"	0.375	14.71	7" x 4"	0.188	13.25	12" x 4"	0.250	25.82
4" x 4"	0.313	14.82	5" x 2"	0.125	5.60	7" x 4"	0.250	17.31	12" x 4"	0.313	31.84
4" x 4"	0.375	17.26	5" x 2"	0.188	8.14	7" x 4"	0.313	21.20	12" x 4"	0.375	37.68
5" x 5"	0.125	8.16	5" x 2"	0.250	10.51	7" x 4"	0.375	24.92	12" x 4"	0.500	48.83
5" x 5"	0.188	11.97	5" x 2"	0.313	12.69	7" x 5"	0.188	14.52	12" x 6"	0.250	29.22
5" x 5"	0.250	15.61	5" x 2"	0.375	14.71	7" x 5"	0.250	19.01	12" x 6"	0.313	36.09
5" x 5"	0.313	19.08	5" x 3"	0.125	6.46	7" x 5"	0.313	23.33	12" x 6"	0.375	42.78
5" x 5"	0.375	22.36	5" x 3"	0.188	9.42	7" x 5"	0.375	27.47	12" x 6"	0.500	55.64
5" x 5"	0.500	28.41	5" x 3"	0.250	12.21	7" x 5"	0.500	35.22	12" x 8"	0.250	32.63
6" x 6"	0.188	14.52	5" x 3"	0.313	14.82	8" x 2"	0.188	11.97	12" x 8"	0.313	40.35
6" x 6"	0.250	19.01	5" x 3"	0.375	17.26	8" x 2"	0.250	15.61	12" x 8"	0.375	47.89
6" x 6"	0.313	23.33	5" x 4"	0.125	7.31	8" x 3"	0.188	13.25	12" x 8"	0.500	62.45
6" x 6"	0.375	27.47	5" x 4"	0.188	10.70	8" x 3"	0.250	17.31			
6" x 6"	0.500	35.22	5" x 4"	0.250	13.91	8" x 3"	0.313	21.20			
7" x 7"	0.188	17.08	5" x 4"	0.313	16.95	8" x 3"	0.375	24.92			
7" x 7"	0.250	22.42	5" x 4"	0.375	19.81	8" x 4"	0.188	14.52			
7" x 7"	0.313	27.58	6" x 2"	0.125	6.46	8" x 4"	0.250	19.01			
7" x 7"	0.375	32.57	6" x 2"	0.188	9.42	8" x 4"	0.313	23.33			
7" x 7"	0.500	42.03	6" x 2"	0.250	12.21	8" x 4"	0.375	27.47			
8" x 8"	0.188	19.63	6" x 2"	0.313	14.82	8" x 4"	0.500	35.22			
8" x 8"	0.250	25.82	6" x 2"	0.375	17.26	8" x 6"	0.188	17.08			
8" x 8"	0.313	31.84	6" x 3"	0.125	7.31	8" x 6"	0.250	22.42			
8" x 8"	0.375	37.68	6" x 3"	0.188	10.70	8" x 6"	0.313	27.58			
8" x 8"	0.500	48.83	6" x 3"	0.250	13.91	8" x 6"	0.375	32.57			
10" x 10"	0.250	32.63	6" x 3"	0.313	16.95	8" x 6"	0.500	42.03			
10" x 10"	0.313	40.35	6" x 3"	0.375	19.81	10" x 2"	0.188	14.52			
10" x 10"	0.375	47.89				10" x 2"	0.250	19.01			
10" x 10"	0.500	62.45									

Courtesy Columbia Structural Tubing.

APPENDIX V  
STRUCTURAL METAL SHAPE DESIGNATIONS

TABLE 28

**W SHAPES  
Dimensions**

Designation	Area A in. <sup>2</sup>	Depth d in.	Web		Flange		Distance			
			Thickness t <sub>w</sub> in.	$\frac{t_w}{2}$ in.	Width b <sub>f</sub> in.	Thickness t <sub>f</sub> in.	T in.	k in.	k <sub>1</sub> in.	
W 10x112	32.9	11.36	0.755	3/4	10.415	10 <sup>3</sup> / <sub>8</sub>	1 1/4	7 5/8	17/8	15/16
x100	29.4	11.10	0.680	11/16	10.340	10 <sup>3</sup> / <sub>8</sub>	1 1/8	7 5/8	1 3/4	7/8
x 88	25.9	10.84	0.605	5/8	10.265	10 <sup>1</sup> / <sub>4</sub>	0.990	7 5/8	1 5/8	13/16
x 77	22.6	10.60	0.530	1/2	10.190	10 <sup>1</sup> / <sub>4</sub>	0.870	7 5/8	1 1/2	13/16
x 68	20.0	10.40	0.470	1/2	10.130	10 <sup>1</sup> / <sub>4</sub>	0.770	7 5/8	1 3/8	3/4
x 60	17.6	10.22	0.420	7/16	10.080	10 <sup>1</sup> / <sub>4</sub>	0.680	7 5/8	1 1/16	3/4
x 54	15.8	10.09	0.370	3/8	10.030	10	0.615	7 5/8	1 1/4	11/16
x 49	14.4	9.98	0.340	5/16	10.000	10	0.560	7 5/8	1 3/16	11/16
W 10x 45	13.3	10.10	0.350	3/8	8.020	8	0.620	7 5/8	1 1/4	11/16
x 39	11.5	9.92	0.315	5/16	7.985	8	0.530	7 5/8	1 1/8	11/16
x 33	9.71	9.73	0.290	5/16	7.960	8	0.435	7 5/8	1 1/16	11/16
W 10x 30	8.84	10.47	0.300	5/16	5.810	5 3/4	0.510	8 5/8	1 5/16	1/2
x 26	7.61	10.33	0.260	1/4	5.770	5 3/4	0.440	8 5/8	7/8	1/2
x 22	6.49	10.17	0.240	1/4	5.750	5 3/4	0.360	8 5/8	3/4	1/2
W 10x 19	5.62	10.24	0.250	1/4	4.020	4	0.395	8 5/8	13/16	1/2
x 17	4.99	10.11	0.240	1/4	4.010	4	0.330	8 5/8	3/4	1/2
x 15	4.41	9.99	0.230	1/4	4.000	4	0.270	8 5/8	1 1/16	7/16
x 12	3.94	9.87	0.190	3/16	3.960	4	0.210	8 5/8	5/8	7/16

AMERICAN INSTITUTE OF STEEL CONSTRUCTION

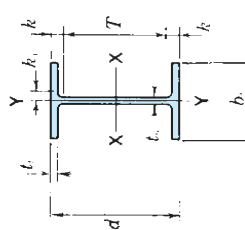
**W SHAPES  
Dimensions**

Designation	Area A in. <sup>2</sup>	Depth d in.	Web		Flange		Distance			
			Thickness t <sub>w</sub> in.	$\frac{t_w}{2}$ in.	Width b <sub>f</sub> in.	Thickness t <sub>f</sub> in.	T in.	k in.	k <sub>1</sub> in.	
W 8x67	19.7	9.00	0.570	5/16	8.280	8 1/4	0.935	15/16	6 1/8	1 1/16
x58	17.1	8.75	0.510	1/2	8.220	8 1/4	0.810	13/16	6 1/8	1 1/16
x48	14.1	8.50	0.400	3/8	8.110	8 1/8	0.685	1 1/16	6 1/8	5/8
x40	11.7	8.25	0.360	3/8	8.070	8 1/8	0.560	9/16	6 1/8	5/8
x35	10.3	8.12	0.310	5/16	8.020	8	0.495	1/2	6 1/8	1 1/16
x31	9.13	8.00	0.285	3/16	7.995	8	0.435	7/16	6 1/8	9/16
W 8x28	8.25	8.06	0.285	5/16	6.535	6 1/2	0.465	7/16	6 1/8	9/16
x24	7.08	7.93	0.245	1/8	6.495	6 1/2	0.400	3/8	6 1/8	3/16
W 8x21	6.16	8.28	0.250	1/8	5.270	5 1/4	0.400	3/8	6 5/8	1/2
x18	5.26	8.14	0.230	1/4	5.250	5 1/4	0.330	5/16	6 5/8	7/16
W 8x15	4.44	8.11	0.245	1/8	4.015	4	0.315	5/16	6 5/8	1/2
x13	3.84	7.99	0.230	1/8	4.000	4	0.255	1/4	6 5/8	1 1/16
x10	2.96	7.89	0.170	3/16	3.940	4	0.205	3/16	6 5/8	7/16
W 6x25	7.34	6.38	0.320	5/16	6.080	6 1/8	0.455	7/16	4 3/4	7/16
x20	5.87	6.20	0.260	1/4	6.020	6	0.365	3/8	4 3/4	7/16
x15	4.43	5.99	0.230	1/4	5.990	6	0.260	1/4	4 3/4	5/8
W 6x16	4.74	6.28	0.260	1/4	4.030	4	0.405	3/8	4 3/4	7/16
x12	3.55	6.03	0.230	1/4	4.000	4	0.280	1/4	4 3/4	5/8
x 9	2.68	5.90	0.170	3/16	3.940	4	0.215	3/16	4 3/4	9/16
W 5x19	5.54	5.15	0.270	1/4	5.030	5	0.430	7/16	3 1/2	7/16
x16	4.68	5.01	0.240	1/4	5.000	5	0.360	3/8	3 1/2	7/16
W 4x13	3.83	4.16	0.280	1/4	4.060	4	0.345	3/8	2 3/4	1 1/16

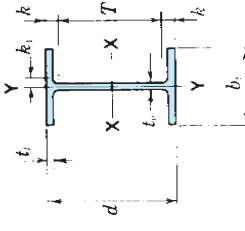
AMERICAN INSTITUTE OF STEEL CONSTRUCTION

APPENDIX V (Continued)

TABLE 28 (CONTINUED)



Designation	Area A in. <sup>2</sup>	Depth d in.	Web		Flange		Distance			
			Thickness t <sub>w</sub> in.	$\frac{t_w}{2}$ in.	Width b <sub>f</sub> in.	Thickness t <sub>f</sub> in.	T in.	k in.	k <sub>1</sub> in.	
W 14x132	38.8	14.66	0.645	5/8	14.725	1.030	1	11 1/4	11 1/4	15 1/8
x120	35.3	14.48	0.590	9/16	14.670	0.940	15/16	11 1/4	11 1/4	15 1/8
x109	32.0	14.32	0.525	1/2	14.605	0.860	7/8	11 1/4	11 1/4	15 1/8
x 99	29.1	14.16	0.485	1/2	14.565	0.780	3/4	11 1/4	11 1/4	15 1/8
x 90	26.5	14.02	0.440	7/16	14.520	0.710	11/16	11 1/4	11 1/4	15 1/8
W 14x 82	24.1	14.31	0.510	1/2	10.130	0.855	7/8	11	11	15 1/8
x 74	21.8	14.17	0.450	7/16	10.070	0.785	13/16	11	11	15 1/8
x 68	20.0	14.04	0.415	7/16	10.035	0.720	3/4	11	11	15 1/8
x 61	17.9	13.89	0.375	3/8	9.995	0.645	5/8	11	11	15 1/8
W 14x 53	15.6	13.92	0.370	3/8	8.060	0.660	11/16	11	11	15 1/8
x 48	14.1	13.79	0.340	5/16	8.030	0.595	5/8	11	11	15 1/8
x 43	12.6	13.66	0.305	5/16	7.995	0.530	1/2	11	11	15 1/8
W 14x 38	11.2	14.10	0.310	5/16	6.770	0.515	1/2	12	12	15 1/8
x 34	10.0	13.98	0.285	5/16	6.745	0.455	7/16	12	12	15 1/8
x 30	8.85	13.84	0.270	1/4	6.730	0.385	3/8	12	12	15 1/8
W 14x 26	7.69	13.91	0.255	1/4	5.025	0.420	7/16	12	12	15 1/8
x 22	6.49	13.74	0.230	1/4	5.000	0.335	5/16	12	12	15 1/8



Designation	Area A in. <sup>2</sup>	Depth d in.	Web		Flange		Distance			
			Thickness t <sub>w</sub> in.	$\frac{t_w}{2}$ in.	Width b <sub>f</sub> in.	Thickness t <sub>f</sub> in.	T in.	k in.	k <sub>1</sub> in.	
W 12x336	98.8	16.82	1.775	1 3/4	13.385	2.955	2 15/16	9 1/2	3 11/16	1 1/2
x305	89.6	16.32	1.625	1 5/8	13.235	2.705	2 11/16	9 1/2	3 7/16	1 1/2
x279	81.9	15.85	1.530	1 1/2	13.140	2.470	2 7/8	9 1/2	3 3/16	1 3/8
x252	74.1	15.41	1.395	1 3/8	13.005	2.250	2 1/4	9 1/2	2 15/16	1 5/16
x230	67.7	15.05	1.285	1 5/16	12.895	2.070	2 1/8	9 1/2	2 3/4	1 1/4
x210	61.8	14.71	1.180	1 3/16	12.790	1.900	1 7/8	9 1/2	2 5/8	1 1/4
x190	55.8	14.38	1.060	1 1/16	12.670	1.735	1 3/4	9 1/2	2 7/16	1 3/16
x170	50.7	14.03	0.960	15/16	12.570	1.560	1 9/16	9 1/2	2 1/4	1 1/8
x152	44.7	13.71	0.870	7/8	12.480	1.400	1 3/8	9 1/2	2 1/8	1 1/16
x136	39.9	13.41	0.790	13/16	12.400	1.250	1 1/4	9 1/2	1 15/16	1
x120	35.3	13.12	0.710	1 1/16	12.320	1.105	1 1/8	9 1/2	1 13/16	1
x106	31.2	12.89	0.610	5/8	12.220	0.990	1	9 1/2	1 11/16	1 5/16
x 96	28.2	12.71	0.550	9/16	12.160	0.900	7/8	9 1/2	1 5/8	7/8
x 87	25.6	12.53	0.515	1/2	12.125	0.810	13/16	9 1/2	1 1/2	7/8
x 79	23.2	12.38	0.470	1/2	12.080	0.735	3/4	9 1/2	1 1/16	7/8
x 72	21.1	12.25	0.430	7/16	12.040	0.670	11/16	9 1/2	1 3/8	7/8
x 65	19.1	12.12	0.390	3/8	12.000	0.605	5/8	9 1/2	1 5/16	13/16
W 12x 58	17.0	12.19	0.360	3/8	10.010	0.640	5/8	9 1/2	1 3/8	13/16
x 53	15.6	12.06	0.345	3/8	9.995	0.575	9/16	9 1/2	1 1/4	13/16
W 12x 50	14.7	12.19	0.370	3/8	8.080	0.640	5/8	9 1/2	1 3/8	13/16
x 45	13.2	12.06	0.335	5/16	8.045	0.575	9/16	9 1/2	1 1/4	13/16
x 40	11.8	11.94	0.295	5/16	8.005	0.515	1/2	9 1/2	1 1/4	3/4
W 12x 35	10.3	12.50	0.300	5/16	6.560	0.520	1/2	10 1/2	1	9/16
x 30	8.79	12.34	0.260	1/4	6.520	0.440	7/16	10 1/2	15/16	1/2
x 26	7.65	12.22	0.230	1/4	6.490	0.380	3/8	10 1/2	7/8	1/2
W 12x 22	6.48	12.31	0.260	1/4	4.030	0.425	7/16	10 1/2	7/8	1/2
x 19	5.57	12.16	0.235	1/4	4.005	0.350	3/8	10 1/2	13/16	1/2
x 16	4.71	11.99	0.220	1/4	3.990	0.265	1/4	10 1/2	3/4	1/2
x 14	4.16	11.91	0.200	3/16	3.970	0.225	1/4	10 1/2	11/16	1/2

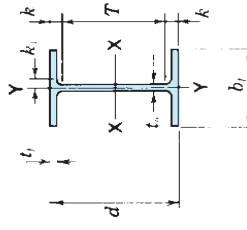
AMERICAN INSTITUTE OF STEEL CONSTRUCTION

AMERICAN INSTITUTE OF STEEL CONSTRUCTION

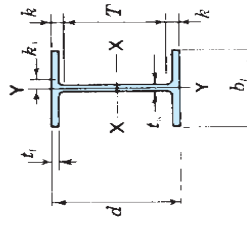


APPENDIX V (Continued)

TABLE 28 (CONTINUED)



Designation	Area A in. <sup>2</sup>	Depth d in.	Web		Flange		Distance			
			Thickness t <sub>w</sub> in.	$\frac{t_w}{2}$ in.	Width b <sub>f</sub> in.	Thickness t <sub>f</sub> in.	T in.	k in.	k <sub>1</sub> in.	
W 18x119	35.1	18.97	0.655	5/16	11.265	1 1/16	15 1/2	1 3/4	15/16	15/16
x106	31.1	18.73	0.590	5/16	11.200	1 1/16	15 1/2	1 3/4	15/16	15/16
x 97	28.5	18.59	0.535	9/16	11.145	1 1/16	15 1/2	1 3/4	7/8	7/8
x 86	25.3	18.39	0.480	1/2	11.090	1 1/8	15 1/2	1 3/4	7/8	7/8
x 76	22.3	18.21	0.425	7/16	11.035	1 1/8	15 1/2	1 3/4	13/16	13/16
W 18x71	20.8	18.47	0.495	1/2	7.635	7/8	15 1/2	1 1/2	7/8	7/8
x 65	19.1	18.35	0.450	7/16	7.590	7/8	15 1/2	1 1/2	7/8	7/8
x 60	17.6	18.24	0.415	7/16	7.555	7/8	15 1/2	1 3/8	13/16	13/16
x 55	16.2	18.11	0.390	3/8	7.530	7/8	15 1/2	1 3/8	13/16	13/16
x 50	14.7	17.99	0.355	3/8	7.495	7/8	15 1/2	1 3/8	13/16	13/16
W 18x46	13.5	18.06	0.360	3/8	6.060	6	15 1/2	1 1/4	13/16	13/16
x 40	11.8	17.90	0.315	5/16	6.015	6	15 1/2	1 3/16	13/16	13/16
x 35	10.3	17.70	0.300	5/16	6.000	6	15 1/2	1 3/8	3/4	3/4
W 16x100	29.4	16.97	0.585	9/16	10.425	10 3/8	13 5/8	1 1 1/16	15/16	15/16
x 89	26.2	16.75	0.525	1/2	10.365	10 3/8	13 5/8	1 1 1/16	7/8	7/8
x 77	22.6	16.52	0.455	7/16	10.295	10 1/4	13 5/8	1 1 1/16	7/8	7/8
x 67	19.7	16.33	0.395	3/8	10.235	10 1/4	13 5/8	1 1 1/16	13/16	13/16
W 16x57	16.8	16.43	0.430	7/16	7.120	7 1/8	13 5/8	1 3/8	7/8	7/8
x 50	14.7	16.26	0.380	3/8	7.070	7 1/8	13 5/8	1 5/16	13/16	13/16
x 45	13.3	16.13	0.345	3/8	7.035	7	13 5/8	1 1/4	13/16	13/16
x 40	11.8	16.01	0.305	5/16	6.995	7	13 5/8	1 3/16	13/16	13/16
x 36	10.6	15.86	0.295	5/16	6.985	7	13 5/8	1 1/8	3/4	3/4
W 16x31	9.12	15.88	0.275	1/4	5.525	5 1/2	13 5/8	1 1/8	3/4	3/4
x 26	7.68	15.69	0.250	1/4	5.500	5 1/2	13 5/8	1 1/16	3/4	3/4



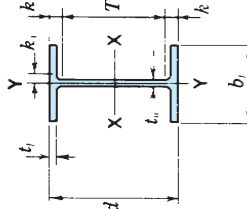
Designation	Area A in. <sup>2</sup>	Depth d in.	Web		Flange		Distance			
			Thickness t <sub>w</sub> in.	$\frac{t_w}{2}$ in.	Width b <sub>f</sub> in.	Thickness t <sub>f</sub> in.	T in.	k in.	k <sub>1</sub> in.	
W 14x730	215.0	22.42	3.070	3 1/16	17.890	4.910	4 15/16	11 1/4	5 9/16	2 9/16
x665	196.0	21.64	2.830	2 13/16	17.650	4.520	4 1/2	11 1/4	5 3/16	2 1/16
x605	178.0	20.92	2.595	2 5/8	17.415	4.160	4 3/16	11 1/4	4 3/16	1 13/16
x550	162.0	20.24	2.380	2 3/8	17.200	3.820	3 3/16	11 1/4	4 1/2	1 3/16
x500	147.0	19.60	2.190	2 1/8	17.010	3.500	3 1/2	11 1/4	4 3/16	1 3/4
x455	134.0	19.02	2.015	2	16.835	3.210	3 1/16	11 1/4	3 7/8	1 5/8
W 14x426	125.0	18.67	1.875	1 7/8	16.695	2.845	2 3/16	11 1/4	3 11/16	1 9/16
x398	117.0	18.29	1.770	1 3/4	16.590	2.645	2 1/8	11 1/4	3 1/2	1 1/2
x370	109.0	17.92	1.655	1 5/8	16.475	2.475	2 1/16	11 1/4	3 3/16	1 1/16
x342	101.0	17.54	1.540	1 1/2	16.360	2.270	2 1/2	11 1/4	3 3/8	1 3/8
x311	91.4	17.12	1.410	1 1/16	16.230	2.060	2 1/4	11 1/4	2 15/16	1 5/16
x283	83.3	16.74	1.290	1 1/16	16.110	1.870	2 1/16	11 1/4	2 3/4	1 1/4
x257	75.6	16.38	1.175	1 3/16	15.995	1.690	1 7/8	11 1/4	2 9/16	1 3/16
x233	68.5	16.04	1.070	1 1/16	15.890	1.520	1 3/4	11 1/4	2 7/8	1 1/16
x211	62.0	15.72	0.980	1 1/2	15.800	1.360	1 5/8	11 1/4	2 1/4	1 1/8
x193	56.8	15.48	0.890	7/8	15.710	1.210	1 1/2	11 1/4	2 1/8	1 1/16
x176	51.8	15.22	0.830	3/4	15.650	1.070	1 1/16	11 1/4	2	1 1/16
x159	46.7	14.98	0.745	3/4	15.565	0.940	1 1/16	11 1/4	1 7/8	1
x145	42.7	14.78	0.680	1 1/16	15.500	0.820	1 1/16	11 1/4	1 3/4	1

AMERICAN INSTITUTE OF STEEL CONSTRUCTION

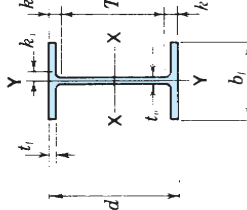
AMERICAN INSTITUTE OF STEEL CONSTRUCTION

APPENDIX V (Continued)

TABLE 28 (CONTINUED)



Designation	Area A in. <sup>2</sup>	Depth d in.	Web		Flange		Distance				
			Thickness t <sub>w</sub> in.	$\frac{t_w}{2}$ in.	Width b <sub>f</sub> in.	Thickness t <sub>f</sub> in.	T in.	k in.	k <sub>1</sub> in.		
W 36x300	88.3	36.74	15 <sup>1</sup> / <sub>16</sub>	1/2	16.655	16 <sup>5</sup> / <sub>16</sub>	1.680	11 <sup>1</sup> / <sub>16</sub>	31 <sup>1</sup> / <sub>16</sub>	21 <sup>13</sup> / <sub>16</sub>	1 <sup>1</sup> / <sub>2</sub>
x280	82.4	36.52	7/8	7/16	16.595	16 <sup>5</sup> / <sub>16</sub>	1.570	19 <sup>1</sup> / <sub>16</sub>	31 <sup>1</sup> / <sub>16</sub>	21 <sup>11</sup> / <sub>16</sub>	1 <sup>1</sup> / <sub>2</sub>
x260	76.5	36.26	13/16	7/16	16.550	16 <sup>1</sup> / <sub>16</sub>	1.440	17/16	31 <sup>1</sup> / <sub>16</sub>	21 <sup>1</sup> / <sub>16</sub>	1 <sup>1</sup> / <sub>2</sub>
x245	72.1	36.08	8/16	7/16	16.510	16 <sup>1</sup> / <sub>16</sub>	1.350	13/8	31 <sup>1</sup> / <sub>16</sub>	21 <sup>1</sup> / <sub>16</sub>	1 <sup>1</sup> / <sub>16</sub>
x230	67.6	35.90	3/4	3/8	16.470	16 <sup>1</sup> / <sub>16</sub>	1.260	11/4	31 <sup>1</sup> / <sub>16</sub>	21 <sup>3</sup> / <sub>8</sub>	1 <sup>1</sup> / <sub>16</sub>
W 36x210	61.8	36.69	13/16	7/16	12.180	12 <sup>1</sup> / <sub>16</sub>	1.360	13/8	32 <sup>1</sup> / <sub>16</sub>	25 <sup>1</sup> / <sub>16</sub>	1 <sup>1</sup> / <sub>4</sub>
x194	57.0	36.49	3/4	3/8	12.115	12 <sup>1</sup> / <sub>16</sub>	1.260	11/4	32 <sup>1</sup> / <sub>16</sub>	23 <sup>1</sup> / <sub>16</sub>	13/16
x182	53.6	36.33	3/4	3/8	12.075	12 <sup>1</sup> / <sub>16</sub>	1.180	13/16	32 <sup>1</sup> / <sub>16</sub>	21 <sup>1</sup> / <sub>8</sub>	13/16
x170	50.0	36.17	11/16	3/8	12.030	12	1.100	11/8	32 <sup>1</sup> / <sub>16</sub>	2	13/16
x160	47.0	36.01	5/8	3/8	12.000	12	1.020	1	32 <sup>1</sup> / <sub>16</sub>	11 <sup>1</sup> / <sub>16</sub>	1 <sup>1</sup> / <sub>8</sub>
x150	44.2	35.85	5/8	5/16	11.975	12	0.940	15/16	32 <sup>1</sup> / <sub>16</sub>	17/8	1 <sup>1</sup> / <sub>8</sub>
x135	39.7	35.55	5/8	5/16	11.950	12	0.790	13/16	32 <sup>1</sup> / <sub>16</sub>	11 <sup>1</sup> / <sub>16</sub>	1 <sup>1</sup> / <sub>8</sub>
W 33x241	70.9	34.18	13/16	7/16	15.860	15 <sup>1</sup> / <sub>16</sub>	1.400	13/8	29 <sup>3</sup> / <sub>4</sub>	23 <sup>1</sup> / <sub>16</sub>	13/16
x221	65.0	33.93	3/4	3/8	15.805	15 <sup>3</sup> / <sub>16</sub>	1.275	11/4	29 <sup>3</sup> / <sub>4</sub>	21 <sup>1</sup> / <sub>4</sub>	13/16
x201	59.1	33.68	11/16	3/8	15.745	15 <sup>3</sup> / <sub>16</sub>	1.150	11/8	29 <sup>3</sup> / <sub>4</sub>	11 <sup>1</sup> / <sub>16</sub>	1 <sup>1</sup> / <sub>8</sub>
W 33x152	44.7	33.49	5/8	5/16	11.565	11 <sup>1</sup> / <sub>16</sub>	1.055	11/16	29 <sup>3</sup> / <sub>4</sub>	17/8	1 <sup>1</sup> / <sub>8</sub>
x141	41.6	33.30	3/4	5/16	11.535	11 <sup>1</sup> / <sub>16</sub>	0.960	15/16	29 <sup>3</sup> / <sub>4</sub>	13/4	1 <sup>1</sup> / <sub>16</sub>
x130	38.3	33.09	9/16	5/16	11.510	11 <sup>1</sup> / <sub>16</sub>	0.855	7/8	29 <sup>3</sup> / <sub>4</sub>	11 <sup>1</sup> / <sub>16</sub>	1 <sup>1</sup> / <sub>16</sub>
x118	34.7	32.86	5/16	5/16	11.480	11 <sup>1</sup> / <sub>16</sub>	0.740	3/4	29 <sup>3</sup> / <sub>4</sub>	19/16	1 <sup>1</sup> / <sub>16</sub>
W 30x211	62.0	30.94	3/4	3/8	15.105	15 <sup>1</sup> / <sub>16</sub>	1.315	15/16	26 <sup>3</sup> / <sub>4</sub>	21/8	1 <sup>1</sup> / <sub>8</sub>
x191	56.1	30.68	30 <sup>5</sup> / <sub>16</sub>	3/8	15.040	15	1.185	13/16	26 <sup>3</sup> / <sub>4</sub>	11 <sup>1</sup> / <sub>16</sub>	1 <sup>1</sup> / <sub>16</sub>
x173	50.8	30.44	5/8	5/16	14.985	15	1.065	11/16	26 <sup>3</sup> / <sub>4</sub>	17/8	1 <sup>1</sup> / <sub>16</sub>
W 30x132	38.9	30.31	5/8	5/16	10.545	10 <sup>1</sup> / <sub>2</sub>	1.000	1	26 <sup>3</sup> / <sub>4</sub>	13/4	1 <sup>1</sup> / <sub>16</sub>
x124	36.5	30.17	9/16	5/16	10.515	10 <sup>1</sup> / <sub>2</sub>	0.930	15/16	26 <sup>3</sup> / <sub>4</sub>	11/4	1
x116	34.2	30.01	5/16	5/16	10.495	10 <sup>1</sup> / <sub>2</sub>	0.850	7/8	26 <sup>3</sup> / <sub>4</sub>	15/8	1
x108	31.7	29.83	29 <sup>7</sup> / <sub>16</sub>	5/16	10.475	10 <sup>1</sup> / <sub>2</sub>	0.760	3/4	26 <sup>3</sup> / <sub>4</sub>	19/16	1
x 99	29.1	29.65	29 <sup>5</sup> / <sub>16</sub>	1/4	10.450	10 <sup>1</sup> / <sub>2</sub>	0.670	11/16	26 <sup>3</sup> / <sub>4</sub>	17/16	1



Designation	Area A in. <sup>2</sup>	Depth d in.	Web		Flange		Distance				
			Thickness t <sub>w</sub> in.	$\frac{t_w}{2}$ in.	Width b <sub>f</sub> in.	Thickness t <sub>f</sub> in.	T in.	k in.	k <sub>1</sub> in.		
W 27x178	52.3	27.81	3/4	3/8	14.085	14 <sup>1</sup> / <sub>8</sub>	1.190	13/16	24	17/8	1 <sup>1</sup> / <sub>16</sub>
x161	47.4	27.59	11/16	3/8	14.020	14	1.080	11/16	24	11 <sup>13</sup> / <sub>16</sub>	1
x146	42.9	27.38	5/8	5/16	13.965	14	0.975	1	24	11 <sup>1</sup> / <sub>16</sub>	1
W 27x114	33.5	27.29	9/16	5/16	10.070	10 <sup>1</sup> / <sub>8</sub>	0.930	15/16	24	15/8	15/16
x102	30.0	27.09	1/2	1/4	10.015	10	0.830	13/16	24	19/16	15/16
x 94	27.7	26.92	1/2	1/4	9.990	10	0.745	3/4	24	17/16	15/16
x 84	24.8	26.71	7/16	1/4	9.960	10	0.640	5/8	24	13/8	15/16
W 24x162	47.7	25.00	11/16	5/8	12.955	13	1.220	11/4	21	2	1 <sup>1</sup> / <sub>16</sub>
x146	43.0	24.74	5/8	5/8	12.900	12 <sup>7</sup> / <sub>8</sub>	1.090	11/16	21	17/8	1 <sup>1</sup> / <sub>16</sub>
x131	38.5	24.48	5/8	5/8	12.855	12 <sup>7</sup> / <sub>8</sub>	0.960	13/16	21	13/4	1 <sup>1</sup> / <sub>16</sub>
x117	34.4	24.26	9/16	5/8	12.800	12 <sup>3</sup> / <sub>4</sub>	0.850	7/8	21	15/8	1
x104	30.6	24.06	1/2	1/4	12.750	12 <sup>3</sup> / <sub>4</sub>	0.750	3/4	21	11/2	1
W 24x 94	27.7	24.31	1/2	1/4	9.065	9 <sup>1</sup> / <sub>8</sub>	0.875	7/8	21	15/8	1
x 84	24.7	24.10	1/2	1/4	9.020	9	0.770	3/4	21	19/16	15/16
x 76	22.4	23.92	7/16	1/4	8.990	9	0.680	11/16	21	17/16	15/16
x 68	20.1	23.73	7/16	1/4	8.965	9	0.585	9/16	21	13/8	15/16
W 24x 62	18.2	23.74	7/16	1/4	7.040	7	0.590	9/16	21	13/8	15/16
x 55	16.2	23.57	3/8	3/16	7.005	7	0.505	1/2	21	15/16	15/16
W 21x147	43.2	22.06	3/4	3/8	12.510	12 <sup>1</sup> / <sub>2</sub>	1.150	11/8	18 <sup>1</sup> / <sub>4</sub>	17/8	1 <sup>1</sup> / <sub>16</sub>
x132	38.8	21.83	5/8	5/16	12.440	12 <sup>1</sup> / <sub>2</sub>	1.035	13/16	18 <sup>1</sup> / <sub>4</sub>	13 <sup>1</sup> / <sub>16</sub>	1
x122	35.9	21.68	11/16	5/16	12.390	12 <sup>3</sup> / <sub>4</sub>	0.900	15/16	18 <sup>1</sup> / <sub>4</sub>	11 <sup>1</sup> / <sub>16</sub>	1
x111	32.7	21.51	9/16	5/16	12.340	12 <sup>3</sup> / <sub>4</sub>	0.875	7/8	18 <sup>1</sup> / <sub>4</sub>	15/8	15/16
x101	29.8	21.36	1/2	1/4	12.290	12 <sup>3</sup> / <sub>4</sub>	0.800	13/16	18 <sup>1</sup> / <sub>4</sub>	19/16	15/16
W 21x 93	27.3	21.62	9/16	5/16	8.420	8 <sup>5</sup> / <sub>8</sub>	0.930	15/16	18 <sup>1</sup> / <sub>4</sub>	11 <sup>1</sup> / <sub>16</sub>	1
x 83	24.3	21.43	1/2	1/4	8.355	8 <sup>3</sup> / <sub>8</sub>	0.835	13/16	18 <sup>1</sup> / <sub>4</sub>	19/16	15/16
x 73	21.5	21.24	7/16	1/4	8.295	8 <sup>1</sup> / <sub>4</sub>	0.740	3/4	18 <sup>1</sup> / <sub>4</sub>	11/2	15/16
x 68	20.0	21.13	7/16	1/4	8.270	8 <sup>1</sup> / <sub>4</sub>	0.685	11/16	18 <sup>1</sup> / <sub>4</sub>	17/16	7/8
x 62	18.3	20.99	3/8	3/16	8.240	8 <sup>1</sup> / <sub>4</sub>	0.615	5/8	18 <sup>1</sup> / <sub>4</sub>	13/8	7/8
W 21x 57	16.7	21.06	3/8	3/16	6.555	6 <sup>1</sup> / <sub>2</sub>	0.650	5/8	18 <sup>1</sup> / <sub>4</sub>	13/8	7/8
x 50	14.7	20.83	3/8	3/16	6.530	6 <sup>1</sup> / <sub>2</sub>	0.535	9/16	18 <sup>1</sup> / <sub>4</sub>	15/16	7/8
x 44	13.0	20.66	3/8	3/16	6.500	6 <sup>1</sup> / <sub>2</sub>	0.450	7/16	18 <sup>1</sup> / <sub>4</sub>	13/16	7/8

AMERICAN INSTITUTE OF STEEL CONSTRUCTION

AMERICAN INSTITUTE OF STEEL CONSTRUCTION

APPENDIX V (Continued)

TABLE 28 (CONTINUED)

**S SHAPES**  
Dimensions

Designation	Area A In. <sup>2</sup>	Depth d In.	Web		Flange		Distance T In.	Grip In.	Max. Flg. Fas-ten-ter
			Thickness t <sub>w</sub> In.	t <sub>w</sub> / Z In.	Width b <sub>f</sub> In.	Thickness t <sub>f</sub> In.			
S 24x121 x106	35.6 31.2	24.50 24.50	0.800 0.620	7/16 5/16	8.050 7.870	8 7/8	20 1/2 20 1/2	1 1/8 1 1/8	1 1
S 24x100 x90 x80	29.3 26.5 23.5	24.00 24.00 24.00	0.745 0.625 0.500	3/8 5/16 1/4	7.245 7.125 7.000	7/4 7/8 7	20 1/2 20 1/2 20 1/2	7/8 7/8 7/8	1 1 1
S 20x96 x86	28.2 25.3	20.30 20.30	0.800 0.660	13/16 3/8	7.200 7.060	7/4 7	16 3/4 16 3/4	15/16 15/16	1 1
S 20x75 x66	22.0 19.4	20.00 20.00	0.635 0.505	5/8 1/2	6.385 6.255	6 3/8 6 1/4	16 3/4 16 3/4	1 5/8 1 5/8	7/8 7/8
S 18x70 x54.7	20.6 18.00	18.00 18.00	0.711 0.461	11/16 3/8	6.251 6.001	6 1/4 6	15 15	1 1/2 1 1/2	7/8 7/8
S 15x50 x42.9	14.7 12.6	15.00 15.00	0.550 0.411	9/16 1/4	5.640 5.501	5 7/8 5 1/2	12 1/4 12 1/4	9/16 9/16	3/4 3/4
S 12x50 x40.8	14.7 12.0	12.00 12.00	0.687 0.462	11/16 7/16	5.477 5.252	5 1/2 5 1/4	9 1/8 9 1/8	1 1/16 1 1/16	3/4 3/4
S 12x35 x31.8	10.3 9.35	12.00 12.00	0.428 0.350	7/16 3/8	5.078 5.000	5 1/8 5	9 5/8 9 5/8	1 3/16 1 3/16	3/4 3/4
S 10x35 x25.4	10.3 7.46	10.00 10.00	0.594 0.311	5/8 5/16	4.944 4.661	5 4 5/8	7 3/4 7 3/4	1 1/2 1 1/2	3/4 3/4
S 8x23 x18.4	6.77 5.41	8.00 8.00	0.441 0.271	7/16 1/4	4.171 4.001	4 1/8 4	6 6	7/16 7/16	3/4 3/4
S 7x20 x15.3	5.88 4.50	7.00 7.00	0.450 0.252	7/16 1/4	3.860 3.662	3 7/8 3 5/8	5 1/8 5 1/8	1 5/16 1 5/16	5/8 5/8
S 6x17.25 x12.5	5.07 3.67	6.00 6.00	0.465 0.232	7/16 1/4	3.565 3.332	3 5/8 3 3/8	4 1/4 4 1/4	3/8 3/8	5/8 5/8
S 5x14.75 x10	4.34 2.94	5.00 5.00	0.494 0.214	1/2 3/16	3.284 3.004	3 1/4 3	3 3/8 3 3/8	5/16 5/16	5/8 5/8
S 4x9.5 x7.7	2.79 2.26	4.00 4.00	0.326 0.193	5/16 3/16	2.796 2.663	2 3/4 2 5/8	2 1/2 2 1/2	3/4 3/4	5/8 5/8
S 3x7.5 x5.7	2.21 1.67	3.00 3.00	0.349 0.170	3/8 3/16	2.509 2.330	2 1/2 2 3/8	1 5/8 1 5/8	1/4 1/4	5/8 5/8

AMERICAN INSTITUTE OF STEEL CONSTRUCTION

**M SHAPES**  
Dimensions

Designation	Area A In. <sup>2</sup>	Depth d In.	Web		Flange		Distance T In.	Grip In.	Max. Flg. Fas-ten-ter
			Thickness t <sub>w</sub> In.	t <sub>w</sub> / Z In.	Width b <sub>f</sub> In.	Thickness t <sub>f</sub> In.			
M 14x18	5.10	14.00	0.215	3/16	4.000	4	12 3/4	5/8	3/4
M 12x11.8	3.47	12.00	0.177	3/16	3.065	3 1/8	10 7/8	9/16	—
M 10x9	2.65	10.00	0.157	3/16	2.690	2 3/4	8 7/8	9/16	—
M 8x6.5	1.92	8.00	0.135	1/8	2.281	2 1/4	7	1/2	—
M 6x20	5.89	6.00	0.250	1/4	5.938	6	4 1/4	7/8	7/8
M 6x4.4	1.29	6.00	0.114	1/8	1.844	1 7/8	5 7/16	7/16	—
M 5x18.9	5.55	5.00	0.316	5/16	5.003	5	3 1/4	7/8	7/8
M 4x13	3.81	4.00	0.254	1/4	3.940	4	2 3/8	1 3/16	3/4

AMERICAN INSTITUTE OF STEEL CONSTRUCTION

APPENDIX V (Continued)

TABLE 29

**CHANNELS  
AMERICAN STANDARD  
Dimensions**

Designation	Area A In. <sup>2</sup>	Depth d In.	Web		Flange		Distance		Max. Fig. Fastener		
			Thickness t <sub>w</sub> In.	$\frac{t_w}{2}$ In.	Width b <sub>f</sub> In.	Average thickness t <sub>f</sub> In.	T In.	k In.		Grip In.	
C 15x50 x40 x33.9	14.7 11.8 9.96	15.00 15.00 15.00	0.716	3/8	3.716	3/4	0.650	5/8	12 1/8	1 7/16	5/8
			0.520	1/2	3.520	3 1/2	0.650	5/8	12 1/8	1 7/16	5/8
			0.400	3/8	3.400	3 3/8	0.650	5/8	12 1/8	1 7/16	5/8
C 12x30 x25 x20.7	8.82 7.35 6.09	12.00 12.00 12.00	0.510	1/4	3.170	3/8	0.501	1/2	9 3/4	1 1/8	1/2
			0.387	3/8	3.047	3	0.501	1/2	9 3/4	1 1/8	1/2
			0.282	5/16	2.942	3	0.501	1/2	9 3/4	1 1/8	1/2
C 10x30 x25 x20 x15.3	8.82 7.35 5.88 4.49	10.00 10.00 10.00 10.00	0.673	11/16	3.033	3	0.436	7/16	8	1	7/16
			0.526	1/2	2.886	2 1/8	0.436	7/16	8	1	7/16
			0.379	3/8	2.739	2 3/4	0.436	7/16	8	1	7/16
C 9x20 x15 x13.4	5.88 4.41 3.94	9.00 9.00 9.00	0.448	1/4	2.648	2 5/8	0.413	7/16	7 1/8	1 5/16	3/4
			0.285	5/16	2.485	2 1/2	0.413	7/16	7 1/8	1 5/16	3/4
			0.233	1/4	2.433	2 3/8	0.413	7/16	7 1/8	1 5/16	3/4
C 8x18.75 x13.75 x11.5	5.51 4.04 3.38	8.00 8.00 8.00	0.487	1/4	2.527	2 1/2	0.390	3/8	6 1/8	1 5/16	3/4
			0.303	5/16	2.343	2 3/8	0.390	3/8	6 1/8	1 5/16	3/4
			0.220	1/4	2.260	2 1/4	0.390	3/8	6 1/8	1 5/16	3/4
C 7x14.75 x12.25 x 9.8	4.33 3.60 2.87	7.00 7.00 7.00	0.419	7/16	2.299	2 1/4	0.366	3/8	5 1/4	7/8	5/8
			0.314	5/16	2.194	2 1/4	0.366	3/8	5 1/4	7/8	5/8
			0.210	3/16	2.090	2 1/8	0.366	3/8	5 1/4	7/8	5/8
C 6x13 x10.5 x 8.2	3.83 3.09 2.40	6.00 6.00 6.00	0.437	7/16	2.157	2 1/8	0.343	5/16	4 3/8	1 3/16	5/8
			0.314	5/16	2.034	2	0.343	5/16	4 3/8	1 3/16	5/8
			0.200	3/16	1.920	1 7/8	0.343	5/16	4 3/8	1 3/16	5/8
C 5x 9 x 6.7	2.64 1.97	5.00 5.00	0.325	5/16	1.885	1 7/8	0.320	5/16	3 1/2	3/4	5/8
			0.190	3/16	1.750	1 3/4	0.320	5/16	3 1/2	3/4	5/8
			0.321	5/16	1.721	1 3/4	0.296	5/16	2 5/8	1 1/16	5/8
C 4x 7.25 x 5.4	1.59 1.76	4.00 4.00	0.184	3/16	1.584	1 5/8	0.296	5/16	2 5/8	1 1/16	5/8
			0.356	3/8	1.596	1 5/8	0.273	1/4	1 5/8	1 1/16	5/8
			0.258	1/4	1.498	1 1/2	0.273	1/4	1 5/8	1 1/16	5/8
C 3x 6 x 5 x 4.1	1.47 1.21	3.00 3.00	0.170	3/16	1.410	1 3/8	0.273	1/4	1 5/8	1 1/16	5/8
			0.356	3/8	1.596	1 5/8	0.273	1/4	1 5/8	1 1/16	5/8
			0.258	1/4	1.498	1 1/2	0.273	1/4	1 5/8	1 1/16	5/8

AMERICAN INSTITUTE OF STEEL CONSTRUCTION

TABLE 28 (CONTINUED)

**HP SHAPES  
Dimensions**

Designation	Area A In. <sup>2</sup>	Depth d In.	Web		Flange		Distance		Max. Fig. Fastener	
			Thickness t <sub>w</sub> In.	$\frac{t_w}{2}$ In.	Width b <sub>f</sub> In.	Thickness t <sub>f</sub> In.	T In.	k In.		
HP 14x117 x102 x 89 x 73	34.4 30.0 26.1 21.4	14 1/4 14 13 3/8 13 5/8	0.805	1 3/16	14.885	1 7/8	0.805	1 3/16	11 1/4	1 1/16
			0.705	1 1/16	14.785	1 3/4	0.705	1 1/16	11 1/4	1 3/8
			0.615	5/8	14.695	1 3/4	0.615	5/8	11 1/4	1 5/16
			0.505	1/2	14.585	1 4 5/8	0.505	1/2	11 1/4	1 3/16
HP 13x100 x 87 x 73 x 60	29.4 25.5 21.6 17.5	13 1/8 12.95 12 3/4 12 1/2	0.765	3/4	13.205	1 3/4	0.765	3/4	10 1/4	1 7/16
			0.665	1 1/16	13.105	1 3/8	0.665	1 1/16	10 1/4	1 3/8
			0.565	9/16	13.005	1 3	0.565	9/16	10 1/4	1 1/4
			0.460	7/16	12.900	1 2 7/8	0.460	7/16	10 1/4	1 1/8
HP 12x 84 x 74 x 63 x 53	24.6 21.8 18.4 15.5	12.28 12.13 11.94 11.78	0.685	1 1/16	12.295	1 1/4	0.685	1 1/16	9 1/2	1 3/8
			0.605	5/8	12.215	1 2 1/4	0.610	5/8	9 1/2	1 5/16
			0.515	1/2	12.125	1 2 1/8	0.515	1/2	9 1/2	1 1/4
			0.435	7/16	12.045	1 2	0.435	7/16	9 1/2	1 1/8
HP 10x 57 x 42	16.8 12.4	9.99 9.70	0.565	9/16	10.225	1 1/4	0.565	9/16	7 5/8	1 3/16
			0.415	7/16	10.075	1 1 1/8	0.420	7/16	7 5/8	1 1/16
HP 8x 36	10.6	8.02	0.445	7/16	8.155	8 1/8	0.445	7/16	6 1/8	1 5/16

AMERICAN INSTITUTE OF STEEL CONSTRUCTION

APPENDIX V (Continued)

TABLE 29 (CONTINUED)

Designation	Area A in. <sup>2</sup>	Depth d in.	Web		Flange		Distance		Max. Flg. Fas-ten-ter				
			Thickness t <sub>w</sub> in.	t <sub>w</sub> /2 in.	Width b <sub>f</sub> in.	Average thickness t <sub>f</sub> in.	T in.	k in.					
										Thickness t <sub>w</sub> in.	t <sub>w</sub> /2 in.		
MC 18x58	17.1	18.00	0.700	11/16	3/8	4.200	4 1/4	0.625	5/8	15 1/4	1 3/8	5/8	1
x51.9	15.3	18.00	0.600	5/8	5/16	4.100	4 1/8	0.625	5/8	15 1/4	1 3/8	5/8	1
x45.8	13.5	18.00	0.500	1/2	1/4	4.000	4	0.625	5/8	15 1/4	1 3/8	5/8	1
x42.7	12.6	18.00	0.450	7/16	1/4	3.950	4	0.625	5/8	15 1/4	1 3/8	5/8	1
MC 13x50	14.7	13.00	0.787	13/16	3/8	4.412	4 3/8	0.610	5/8	10 1/4	1 3/8	5/8	1
x40	11.8	13.00	0.560	9/16	1/4	4.185	4 1/8	0.610	5/8	10 1/4	1 3/8	9/16	1
x35	10.3	13.00	0.447	7/16	1/4	4.072	4 1/8	0.610	5/8	10 1/4	1 3/8	9/16	1
x31.8	9.35	13.00	0.375	3/8	3/16	4.000	4	0.610	5/8	10 1/4	1 3/8	9/16	1
MC 12x50	14.7	12.00	0.835	13/16	7/16	4.135	4 1/8	0.700	11/16	9 3/8	1 5/16	11/16	1
x45	13.2	12.00	0.712	11/16	3/8	4.012	4	0.700	11/16	9 3/8	1 5/16	11/16	1
x40	11.8	12.00	0.590	9/16	5/16	3.890	3 7/8	0.700	11/16	9 3/8	1 5/16	11/16	1
x35	10.3	12.00	0.467	7/16	1/4	3.767	3 3/4	0.700	11/16	9 3/8	1 5/16	11/16	1
MC 12x37	10.9	12.00	0.600	5/8	5/16	3.600	3 5/8	0.600	5/8	9 3/8	1 5/16	5/8	7/8
x32.9	9.67	12.00	0.500	1/2	1/4	3.500	3 1/2	0.600	5/8	9 3/8	1 5/16	9/16	7/8
x30.9	9.07	12.00	0.450	7/16	1/4	3.450	3 1/2	0.600	5/8	9 3/8	1 5/16	9/16	7/8
MC 12x10.6	3.10	12.00	0.190	3/16	1/8	1.500	1 1/2	0.309	5/16	10 5/8	1 1/16	—	—
MC 10x41.1	12.1	10.00	0.796	13/16	3/8	4.321	4 3/8	0.575	9/16	7 1/2	1 1/4	9/16	7/8
x33.6	9.87	10.00	0.575	9/16	5/16	4.100	4 1/8	0.575	9/16	7 1/2	1 1/4	9/16	7/8
x28.5	8.37	10.00	0.425	7/16	3/16	3.950	4	0.575	9/16	7 1/2	1 1/4	9/16	7/8
MC 10x28.3	8.32	10.00	0.477	1/2	1/4	3.502	3 1/2	0.575	9/16	7 1/2	1 1/4	9/16	7/8
x25.3	7.43	10.00	0.425	7/16	3/16	3.550	3 1/2	0.500	1/2	7 3/4	1 1/8	1/2	7/8
x24.9	7.32	10.00	0.377	3/8	3/16	3.402	3 3/8	0.575	9/16	7 1/2	1 1/4	9/16	7/8
x21.9	6.43	10.00	0.325	5/16	3/16	3.450	3 1/2	0.500	1/2	7 3/4	1 1/8	1/2	7/8
MC 10x 8.4	2.46	10.00	0.170	3/16	1/16	1.500	1 1/2	0.280	1/4	8 5/8	1 1/16	—	—
MC 10x 6.5	1.91	10.00	0.152	1/8	1/16	1.127	1 1/8	0.202	3/16	9 1/8	7/16	—	—

AMERICAN INSTITUTE OF STEEL CONSTRUCTION

Designation	Area A in. <sup>2</sup>	Depth d in.	Web		Flange		Distance		Max. Flg. Fas-ten-ter				
			Thickness t <sub>w</sub> in.	t <sub>w</sub> /2 in.	Width b <sub>f</sub> in.	Average thickness t <sub>f</sub> in.	T in.	k in.					
										Thickness t <sub>w</sub> in.	t <sub>w</sub> /2 in.		
MC 9x25.4	7.47	9.00	0.450	7/16	1/4	3.500	3 1/2	0.550	9/16	6 5/8	1 3/16	9/16	7/8
x23.9	7.02	9.00	0.400	3/8	3/16	3.450	3 1/2	0.550	9/16	6 5/8	1 3/16	9/16	7/8
MC 8x22.8	6.70	8.00	0.427	7/16	3/16	3.502	3 1/2	0.525	1/2	5 5/8	1 3/16	1/2	7/8
x21.4	6.28	8.00	0.375	3/8	3/16	3.450	3 1/2	0.525	1/2	5 5/8	1 3/16	1/2	7/8
MC 8x20	5.88	8.00	0.400	3/8	3/16	3.025	3	0.500	1/2	5 3/4	1 1/8	1/2	7/8
x18.7	5.50	8.00	0.353	3/8	3/16	2.978	3	0.500	1/2	5 3/4	1 1/8	1/2	7/8
MC 8x 8.5	2.50	8.00	0.179	3/16	1/16	1.874	1 7/8	0.311	5/16	6 1/2	3/4	5/16	5/8
MC 7x22.7	6.67	7.00	0.503	1/2	1/4	3.603	3 5/8	0.500	1/2	4 3/4	1 1/8	1/2	7/8
x19.1	5.61	7.00	0.352	3/8	3/16	3.452	3 1/2	0.500	1/2	4 3/4	1 1/8	1/2	7/8
MC 7x17.6	5.17	7.00	0.375	3/8	3/16	3.000	3	0.475	1/2	4 7/8	1 1/16	1/2	3/4
MC 6x18	5.29	6.00	0.379	3/8	3/16	3.504	3 1/2	0.475	1/2	3 7/8	1 1/16	1/2	7/8
x15.3	4.50	6.00	0.340	5/16	3/16	3.500	3 1/2	0.385	3/8	4 1/4	7/8	3/8	7/8
MC 6x16.3	4.79	6.00	0.375	3/8	3/16	3.000	3	0.475	1/2	3 7/8	1 1/16	1/2	3/4
x15.1	4.44	6.00	0.316	5/16	3/16	2.941	3	0.475	1/2	3 7/8	1 1/16	1/2	3/4
MC 6x12	3.53	6.00	0.310	5/16	1/8	2.497	2 1/2	0.375	3/8	4 3/8	13/16	3/8	5/8

AMERICAN INSTITUTE OF STEEL CONSTRUCTION

**APPENDIX W**  
**CORROSION-RESISTANT PIPE FITTINGS**

**TABLE 30 WELDING FITTINGS—DIMENSIONS**

Nom. Pipe Size	Pipe O.D.	WeldELL						CAPS	STUB ENDS (see note below)						Nom. Pipe Size
		A	B	D	K	V	E		G O.D. of Lap	Type A			Type B,C▲		
										F (Length) ANSI Std.	I (Length) MSS Std.	Corner Radius	I (Length) MSS Std.	Corner Radius	
1/2	0.840	1 1/2	5/8	-	17/8	-	1	13/8	3	2	1/8	2	1/32	1/2	
3/4	1.050	1 1/2	7/8	-	11 1/16	-	1	11 1/16	3	2	1/8	2	1/32	3/4	
1	1.315	1 1/2	1	-	23/16	15/8	1 1/2	2	4	2	1/8	2	1/32	1	
1 1/4	1.660	1 7/8	1 1/8	1 1/4	23/4	2 1/16	1 1/2	2 1/2	4	2	3/16	2	1/32	1 1/4	
1 1/2	1.900	2 1/4	1 1/8	1 1/2	3 1/4	2 7/16	1 1/2	2 7/8	4	2	1/4	2	1/32	1 1/2	
2	2.375	3	1 3/8	2	4 3/16	3 3/16	1 1/2	3 5/8	6	2 1/2	5/16	2 1/2	1/32	2	
2 1/2	2.875	3 3/4	1 3/4	2 1/2	5 3/16	3 5/16	1 1/2	4 1/8	6	2 1/2	5/16	2 1/2	1/32	2 1/2	
3	3.500	4 1/2	2	3	6 1/4	4 3/4	2	5	6	2 1/2	3/8	2 1/2	1/32	3	
3 1/2	4.000	5 1/4	2 1/4	3 1/2	7 1/4	5 1/2	2 1/2	5 1/2	6	3	3/8	3	1/32	3 1/2	
4	4.500	6	2 1/2	4	8 1/4	6 1/4	2 1/2	6 3/16	6	3	7/16	3	1/32	4	
5	5.563	7 1/2	3 1/8	5	10 5/16	7 3/4	3	7 5/16	8	3	7/16	3	1/16	5	
6	6.625	9	3 3/4	6	12 5/16	9 5/16	3 1/2	8	8	3 1/2	1/2	3 1/2	1/16	6	
8	8.625	12	5	8	16 5/16	12 5/16	4	10 5/8	8	4	1/2	4	1/16	8	
10	10.750	15	6 1/4	10	20 3/8	15 3/8	5	12 3/4	10	5	1/2	5	1/16	10	
12	12.750	18	7 1/2	12	24 3/8	18 3/8	6	15	10	6	1/2	6	1/16	12	
14	14.000	21	8 3/4	14	28	21	6 1/2	16 1/4	12	-	1/2	-	-	14	
16	16.000	24	10	16	32	24	7	18 1/2	12	-	1/2	-	-	16	
18	18.000	27	11 1/4	18	36	27	8	21	12	-	1/2	-	-	18	
20	20.000	30	12 1/2	20	40	30	9	23	12	-	1/2	-	-	20	
24	24.000	36	15	24	48	26	10 1/2	27 1/2	12	-	1/2	-	-	24	
30	30.000	45	18 1/2	30	60	45	10 1/2	-	-	-	1/2	-	-	30	

Nom. Pipe Size	Outlet	STRAIGHT TEE			Nom. Pipe Size	Outlet	REDUCING TEE			Nom. Pipe Size	Outlet	CONCENTRIC REDUCER			Nom. Pipe Size	Outlet	ECCENTRIC REDUCER		
		C	M	H			C	M	H			C	M	H			C	M	H
3/4	3/4	1 1/8	...	...	3 1/2	3 1/2	3 3/4	...	...	10	10	8 1/2	...	...	20	20	15	...	...
1/2	1/2	1 1/8	1 1/8	1 1/2		3	3 3/4	3 5/8	4		4	8	8 1/2	8		7	7	18	15
1	1	1 1/2	...	2	2 1/2	3 3/4	3 1/2	4	4	6	8 1/2	7 5/8	7	7	16	15	14	20	20
1 1/4	1 1/4	1 1/2	1 1/2	2	2	3 3/4	3 1/4	4	4	5	8 1/2	7 1/2	7	7	14	15	14	20	20
1 1/2	1 1/2	1 1/2	1 1/2	2	1 1/2	3 3/4	3 1/8	4	4	4	8 1/2	7 1/4	7	7	12	15	13 5/8	20	20
1 1/4	1 1/4	1 7/8	...	...	4	4	4 1/8	...	...	12	12	10	...	...	24	24	17	...	...
1	1	1 7/8	1 7/8	2		3 1/2	4 1/8	4	4		4	10	10	9 1/2		8	8	20	17
1 1/4	1 1/4	1 7/8	1 7/8	2	3	4 1/8	3 7/8	4	4	8	10	9	8	8	20	17	17	...	...
1 1/2	1 1/2	1 7/8	1 7/8	2	2 1/2	4 1/8	3 3/4	4	4	6	10	8 5/8	8	8	18	17	16 1/2	20	20
1 1/2	1 1/2	1 7/8	1 7/8	2	2	4 1/8	3 1/2	4	4	6	10	8 5/8	8	8	16	17	16	20	20
1 1/2	1 1/2	1 7/8	1 7/8	2	1 1/2	4 1/8	3 3/8	4	4	5	10	8 1/2	8	8	14	17	16	20	20
1 1/2	1 1/2	2 1/4	...	2 1/2	5	5	4 7/8	...	...	14	14	11	...	...	30	30	22	...	...
1 1/4	1 1/4	2 1/4	2 1/4	2 1/2		4	4 7/8	4 5/8	5		5	12	11	10 5/8		13	13	24	22
1 1/2	1 1/2	2 1/4	2 1/4	2 1/2	3 1/2	4 7/8	4 1/2	5	5	10	11	10 1/8	13	13	20	22	21	24	24
2	2	2 1/2	...	3	3	4 7/8	4 3/8	5	5	8	11	9 3/4	13	13	18	22	19 1/2	24	24
2	2	2 1/2	2 1/2	3	2 1/2	4 7/8	4 1/4	5	5	6	11	9 3/8	13	13	24	22	20	24	24
2 1/2	2 1/2	2 1/2	2 1/2	3	2	4 7/8	4 1/8	5	5	16	12	...	...	...	16	22	19	24	24
2 1/2	2 1/2	2 1/2	2 1/2	3	6	5 5/8	...	...	...	14	12	12	14	14	14	22	19	24	24
2 1/2	2 1/2	3	...	...	5	5 5/8	5 3/8	5 1/2	5 1/2	12	12	11 5/8	14	14	36	26 1/2	...	...	...
2 1/2	2 1/2	3	2 3/4	3 1/2	4	5 5/8	5 1/8	5 1/2	5 1/2	12	12	11 1/8	14	14	30	26 1/2	25	24	24
2 1/2	2 1/2	3	2 5/8	3 1/2	3 1/2	5 5/8	5	5 1/2	5 1/2	10	12	10 3/4	14	14	24	26 1/2	24	24	24
2 1/2	2 1/2	3	2 1/2	3 1/2	3	5 5/8	4 7/8	5 1/2	5 1/2	8	12	10 3/8	14	14	20	26 1/2	23	24	24
2 1/2	2 1/2	3	2 1/4	3 1/2	2 1/2	5 5/8	4 3/4	5 1/2	5 1/2	6	12	10 3/8	14	14	18	26 1/2	22 1/2	24	24
2 1/2	2 1/2	3	2 1/4	3 1/2	3	5 5/8	4 3/4	5 1/2	5 1/2	18	13 1/2	...	...	...	16	26 1/2	22	24	24
3	3	3 3/8	...	...	8	8	7	...	...	16	13 1/2	13	15	15	42	30	...	...	...
2 1/2	2 1/2	3 3/8	3 1/4	3 1/2		6	7	6 5/8	6	6	14	13 1/2	13	15	15	36	30	28	24
2	2	3 3/8	3	3 1/2	5	7	6 3/8	6	6	12	13 1/2	12 5/8	15	15	30	30	28	24	24
1 1/2	1 1/2	3 3/8	2 7/8	3 1/2	4	7	6 1/8	6	6	10	13 1/2	12 1/8	15	15	24	30	26	24	24
1 1/4	1 1/4	3 3/8	2 3/4	3 1/2	3 1/2	7	6	6	6	8	13 1/2	11 3/4	15	15	20	30	26	24	24

**NOTE:** Fittings having wall thicknesses of 0.065" are furnished with square ends unless otherwise specified.  
**STUB ENDS:** Type A for use with Lap Joint Flanges.  
Types B and C for use with Slip-On-Flanges.

Types A and B are furnished with square inside corner, gasket surfaces machined and minimum lap thickness equal to nominal wall of barrel.  
▲ Dimensions of Type C are same as tabulated for Type B in 5S and 10S thicknesses. Type C is not available in 40S thicknesses. Type C has no fixed corner radius, lap face is not machined. Type C is only available in MSS length. Type B, usually purchased in the MSS length is also available in the ANSI length in Schedules 10S and 40S

APPENDIX W (Continued)

TABLE 30 (CONTINUED)

FORGED FLANGES – DIMENSIONS

Nom. Pipe Size	150 LB. FLANGES							300 LB. FLANGES							400 LB. FLANGES							Nom. Pipe Size	
	O	C <sup>②</sup>	Y <sup>②</sup>			Bolt Circle	No. and Size of Holes	O	C <sup>②</sup>	Y <sup>②</sup>			Bolt Circle	No. and Size of Holes	O	C <sup>②</sup>	Y <sup>②</sup>			Bolt Circle	No. and Size of Holes		
			Weld Neck	Slip On Thrd.	Lap Joint					Weld Neck	Slip On Thrd.	Lap Joint					Weld Neck	Slip On Thrd.	Lap Joint				
1/2	3 1/2	7/16	1 7/8	5/8	5/8	2 3/8	4-5/8	3 3/4	9/16	2 1/16	7/8	7/8	2 5/8	4-5/8	3 3/4	9/16	2 1/16	7/8	7/8	2 5/8	4-5/8	1/2	
3/4	3 7/8	1/2	2 1/16	5/8	5/8	2 3/4	4-5/8	4 9/8	5/8	2 1/4	1	1	3 1/4	4-3/4	4 5/8	5/8	2 1/4	1	1	3 1/4	4-3/4	3/4	
1	4 1/4	9/16	2 3/16	1 1/16	1 1/16	3 1/8	4-5/8	4 7/8	1 1/16	2 7/16	1 1/16	1 1/16	3 1/2	4-3/4	4 7/8	1 1/16	2 7/16	1 1/16	1 1/16	3 1/2	4-3/4	1	
1 1/4	4 5/8	5/8	2 1/4	1 3/16	1 3/16	3 1/2	4-5/8	5 1/4	3/4	2 9/16	1 1/16	1 1/16	3 7/8	4-3/4	5 1/4	1 3/16	2 5/8	1 1/8	1 1/8	3 7/8	4-3/4	1 1/4	
1 1/2	5	1 1/16	2 7/16	7/8	7/8	3 7/8	4-5/8	6 1/8	1 3/16	2 11/16	1 3/16	1 3/16	4 1/2	4-7/8	6 1/8	7/8	2 3/4	1 1/4	1 1/4	4 1/2	4-7/8	1 1/2	
2	6	3/4	2 1/2	1	1	4 3/4	4-3/4	6 1/2	7/8	2 3/4	1 5/16	1 5/16	5	8-3/4	6 1/2	1	2 7/8	1 7/16	1 7/16	5	8-3/4	2	
2 1/2	7	7/8	2 3/4	1 1/8	1 1/8	5 1/2	4-3/4	7 1/2	1	3	1 1/2	1 1/2	5 7/8	8-7/8	7 1/2	1 1/8	3 1/8	1 9/8	1 9/8	5 7/8	8-7/8	2 1/2	
3	7 1/2	1 5/16	2 3/4	1 3/8	1 3/8	6	4-3/4	8 1/4	1 1/8	3 1/8	1 11/16	1 11/16	6 5/8	8-7/8	8 1/4	1 1/4	3 1/4	1 13/16	1 13/16	6 5/8	8-7/8	3	
3 1/2	8 1/2	1 5/16	2 13/16	1 1/4	1 1/4	7	8-3/4	9	1 3/16	3 3/16	1 3/4	1 3/4	7 1/4	8-7/8	9	1 3/8	3 3/8	1 15/16	1 15/16	7 1/4	8-1	3 1/2	
4	9	1 5/16	3	1 5/16	1 5/16	7 1/2	8-3/4	10	1 1/4	3 3/8	1 7/8	1 7/8	7 7/8	8-7/8	10	1 3/8	3 1/2	2	2	7 7/8	8-1	4	
5	10	1 5/16	3 1/2	1 7/16	1 7/16	8 1/2	8-7/8	11	1 3/8	3 7/8	2	2	9 1/4	8-7/8	11	1 1/2	4	2 1/8	2 1/8	9 1/4	8-1	5	
6	11	1 3/2	3 1/2	1 9/16	1 9/16	9 1/2	8-7/8	12 1/2	1 7/16	4 1/8	2 1/16	2 1/16	10 5/8	12-7/8	12 1/2	1 5/8	4 1/16	2 1/4	2 1/4	10 5/8	12-1	6	
8	13 1/2	1 7/8	4	1 3/4	1 3/4	11 3/4	8-7/8	15	1 5/8	4 3/8	2 7/16	2 7/16	13	12-1	15	1 7/8	4 9/8	2 11/16	2 11/16	13	12-1 1/8	8	
10	16	1 3/16	4	1 15/16	1 15/16	14 1/4	12-1	17 1/2	1 7/8	4 5/8	2 5/8	3 3/4	15 1/4	16-1 1/8	17 1/2	2 1/8	4 7/8	2 7/8	4	15 1/4	16-1 1/4	10	
12	19	1 1/4	4 1/2	2 3/16	2 3/16	17	12-1	20 1/2	2	5 1/8	2 7/8	4	17 3/4	16-1 1/4	20 1/2	2 1/4	5 3/8	3 1/8	4 1/4	17 3/4	16-1 3/8	12	
14	21	1 3/8	5	2 1/4	3 1/8	18 3/4	12-1 1/8	23	2 1/8	5 5/8	3	4 3/8	20 1/4	20-1 1/4	23	2 3/8	5 7/8	3 5/16	4 5/8	20 1/4	20-1 3/8	14	
16	23 1/2	1 7/16	5	2 1/2	3 7/16	21 1/4	16-1 1/8	25 1/2	2 1/4	5 3/4	3 1/4	4 3/4	22 1/2	20-1 3/4	25 1/2	2 1/2	6	3 11/16	5	22 1/2	20-1 1/2	16	
18	25	1 9/16	5 1/2	2 1 1/16	3 13/16	22 3/4	16-1 1/4	28	2 3/8	6 1/4	3 1/2	5 1/8	24 3/4	24-1 3/8	28	2 5/8	6 1/2	3 7/8	5 3/8	24 3/4	24-1 1/2	18	
20	27 1/2	1 11/16	5 1 1/16	2 7/8	4 1/16	25	20-1 1/4	30 1/2	2 1/2	6 3/8	3 3/4	5 1/2	27	24-1 3/8	30 1/2	2 3/4	6 3/8	4	5 3/4	27	24-1 5/8	20	
24	32	1 7/8	6 1 1/8	3 1/4	4 3/8	29 1/2	20-1 3/8	36	2 3/4	6 5/8	4 3/16	6	32	24-1 5/8	36	3	6 7/8	4 1/2	6 1/4	32	24-1 7/8	24	
600 LB. FLANGES							900 LB. FLANGES							1500 LB. FLANGES									
1/2	3 3/4	9/16	2 1/16	7/8	7/8	2 5/8	4-5/8	4 3/4	7/8	2 3/8	1 1/4	1 1/4	3 1/4	4-7/8	4 3/4	7/8	2 3/8	1 1/4	1 1/4	3 1/4	4-7/8	1/2	
3/4	4 5/8	5/8	2 1/4	1	1	3 1/4	4-3/4	5 1/8	1	2 3/4	1 3/8	1 3/8	3 1/2	4-7/8	5 1/8	1 7/8	2 3/4	1 3/8	1 3/8	3 1/2	4-7/8	3/4	
1	4 7/8	1 1/16	2 7/16	1 1/16	1 1/16	3 1/2	4-3/4	5 7/8	1 1/8	2 7/8	1 5/8	1 5/8	4	4-1	5 7/8	1 1/8	2 7/8	1 5/8	1 5/8	4	4-1	1	
1 1/4	5 1/4	1 3/16	2 5/8	1 1/8	1 1/8	3 7/8	4-3/4	6 1/4	1 1/8	2 7/8	1 5/8	1 5/8	4 3/8	4-1	6 1/4	1 1/8	2 7/8	1 5/8	1 5/8	4 3/8	4-1	1 1/4	
1 1/2	6 1/8	7/8	2 3/4	1 1/4	1 1/4	4 1/2	4-7/8	7	1 1/4	3 1/4	1 3/4	1 3/4	4 7/8	4-1 1/8	7	1 1/4	3 1/4	1 3/4	1 3/4	4 7/8	4-1 1/8	1 1/2	
2	6 1/2	1	2 7/8	1 7/16	1 7/16	5	8-3/4	8 1/2	1 1/2	4	2 1/4	2 1/4	6 1/2	8-1	8 1/2	1 1/2	4	2 1/4	2 1/4	6 1/2	8-1	2	
2 1/2	7 1/2	1 1/8	3 1/8	1 5/8	1 5/8	5 7/8	8-7/8	9 5/8	1 5/8	4 1/8	2 1/2	2 1/2	7 1/2	8-1 1/8	9 5/8	1 5/8	4 1/8	2 1/2	2 1/2	7 1/2	8-1 1/8	2 1/2	
3	8 1/4	1 1/4	3 1/4	1 13/16	1 13/16	6 5/8	8-7/8	9 1/2	1 1/2	4	2 1/8	2 1/8	7 1/2	8-1	10 1/2	1 7/8	4 5/8	2 7/8	2 7/8	8	8-1 1/4	3	
3 1/2	9	1 3/8	3 3/8	1 15/16	1 15/16	7 1/4	8-1	...	...	...	...	...	...	...	...	...	...	...	...	...	...	...	3 1/2
4	10 3/4	1 1/2	4	2 1/8	2 1/8	8 1/2	8-1	11 1/2	1 3/4	4 1/2	2 3/4	2 3/4	9 1/4	8-1 1/4	12 1/4	2 1/8	4 7/8	3 9/16	3 9/16	9 1/2	8-1 3/8	4	
5	13	1 3/4	4 1/2	2 3/8	2 3/8	10 1/2	8-1 1/8	13 3/4	2	5	3 1/8	3 1/8	11	8-1 3/8	14 3/4	2 7/8	6 1/8	4 1/8	4 1/8	11 1/2	8-1 5/8	5	
6	14	1 7/8	4 5/8	2 5/8	2 5/8	11 1/2	12-1 1/8	15	2 3/16	5 1/2	3 3/8	3 3/8	12 1/2	12-1 1/4	15 1/2	3 1/4	6 3/4	4 11/16	4 11/16	12 1/2	12-1 1/2	6	
8	16 1/2	2 3/16	5 1/4	3	3	13 3/4	12-1 1/4	18 1/2	2 1/2	6 3/8	4	4 1/2	15 1/2	12-1 1/2	19	3 5/8	8 3/8	5 5/8	5 5/8	15 1/2	12-1 3/4	8	
10	20	2 1/2	6	3 3/8	4 3/8	17	16-1 3/8	21 1/2	2 3/4	7 1/4	4 1/4	5	18 1/2	16-1 1/2	23	4 1/4	10	6 1/4	7	19	12-2	10	
12	22	2 5/8	6 1/8	3 5/8	4 5/8	19 1/4	20-1 3/8	24	3 1/8	7 7/8	4 5/8	5 5/8	21	20-1 1/2	26 1/2	4 7/8	11 1/8	7 1/8	8 5/8	22 1/2	16-2 1/8	12	
14	23 3/4	2 3/4	6 1/2	3 11/16	5	20 3/4	20-1 1/2	25 1/4	3 3/8	8 3/8	5 1/8	6 1/8	22	20-1 5/8	29 1/2	5 1/4	11 3/4	...	9 1/2	25	16-2 3/8	14	
16	27	3	7	4 3/16	5 1/2	23 3/4	20-1 5/8	27 3/4	3 1/2	8 1/2	5 1/4	6 1/2	24 1/4	20-1 3/4	32 1/2	5 3/4	12 1/4	...	10 1/4	27 3/4	16-2 5/8	16	
18	29 1/4	3 1/4	7 1/4	4 5/8	6	25 3/4	20-1 3/4	31	4	9	6	7 1/2	27	20-2	36	6 3/8	12 7/8	...	10 7/8	30 1/2	16-2 7/8	18	
20	32	3 1/2	7 1/2	5	6 1/2	28 1/2	24-1 3/4	33 3/4	4 1/4	9 3/4	6 1/4	8 1/4	29 1/2	20-2 1/8	38 3/4	7	14	...	11 1/2	32 3/4	16-3 1/8	20	
24	37	4	8	5 1/2	7 1/4	33	24-2	41	5 1/2	11 1/2	8	10 1/2	35 1/2	20-2 5/8	46	8	...	13	...	39	16-3 5/8	24	
2500 LB. FLANGES							150 LB. FLANGES ① ③							MSS 150 LB. FLANGES ③ ④									
1/2	5 1/4	1 3/16	2 7/8	1 9/16	1 9/16	3 1/2	4-7/8	3 1/2	3/8	7/8	9/16	9/16	2 3/8	4-5/8	3 1/2	5/16	1 7/8	5/8	5/8	2 3/8	4-5/8	1/2	
3/4	5 1/2	1 1/4	3 1/8	1 11/16	1 11/16	3 3/4	4-7/8	3 7/8	3/8	7/8	9/16	9/16	2 3/4	4-5/8	3 7/8	1 1/32	2 1/16	5/8	5/8	2 3/4	4-5/8	3/4	
1	6 1/4	1 3/8	3 1/2	1 7/8	1 7/8	4 1/4	4-1	4 1/4	3/8	7/8	9/16	9/16	3 1/8	4-5/8	4 1/4	3/8	2 3/16	1 1/16	1 1/16	3 1/8	4-5/8	1	
1 1/4	7 1/4	1 1/2	3 3/4	2 1/16	2 1/16	5 1/8	4-1 1/8	5 5/8	3/8	7/8	5/8	5/8	3 1/2	4-5/8	4 5/8	1 3/32	2 1/4	1 3/16	1 3/16	3 1/2	4-5/8	1 1/4	
1 1/2	8	1 3/4	4 3/8	2 3/8	2 3/8	5 3/4	4-1 1/4	5	3/8	7/8	5/8	5/8	3 7/8	4-5/8	5	7/16	2 1/16	7/8	7/8	3 1/8	4-5/8	1 1/2	
2	9 1/4	2	5	2 3/4	2 3/4	6 3/4	8-1 1/8	6	7/16	1	3/4	3/4	4 3/4	4-3/4	6	1/2	2 1/2	1	1	4 3/4	4-3/4	2	
2 1/2	10 1/2	2 1/4	5 5/8	3 1/8	3 1/8	7 3/4	8-1 1/4	7	7/16	1	3/4	3/4	5 1/2	4-3/4	7	9/16	2 3/4	1 1/8	1 1/8	5 1/2	4-3/4	2 1/2	
3	12	2 5/8	6 5/8	3 5/8	3 5/8	9	8-1 3/8	7 1/2	1/2	1 1/8	7/8	7/8	6	4-3/4	7 1/2	5/8	2 3/4	1 3/16	1 3/16	6	4-3/4	3	
4	14	3	7 1/2	4 1/4	4 1/4	10 3/4	8-1 5/8	9	1/2	1 1/8	7/8	7/8	7 1/2	8-3/4	9	1 1/16	3	1 5/16	1 5/16	7 1/2	8-3/4	4	
5	16 1/2	3 5/8	9	5 1/8	5 1/8	12 3/4	8-1 7/8	10	9/16	1 1/4	7/8	7/8	8 1/2	8-7/8	10	3/4	3 1/2	1 7/16	1 7/16	8 1/2	8-7/8	5	
6	19	4 1/4	10 3/4	6	6	14 1/2	8-2 1/8	11	9/16	1 1/4	1 1/4	1 1/4	9 1/2	8-7/8	11	1 3/16	3 1/2	1 9/16	1 9/16	9 1/2	8-7/8	6	
8	21 3/4	5	12 1/2	7	7	17 1/4	12-2 1/8	13	9/16	1 1/4	1 1/4	1 1/4	11 3/4	8-7/8	13 1/2	1 5/16	4	1 3/4	1 3/4	11 3/4	8-7/8	8	
10	26 1/2	6 1/2	16 1/2	9	9	21 1/4	12-2 5/8																

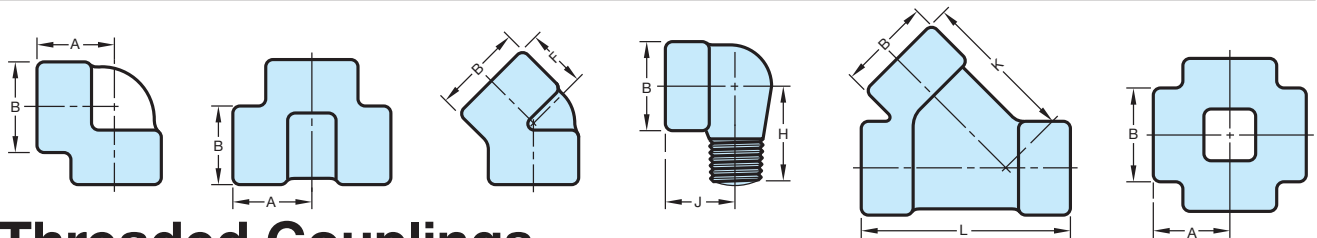
APPENDIX W (Continued)

**TABLE 31 THREADED FITTINGS AND THREADED COUPLINGS, REDUCERS, AND CAPS**

# Threaded Fittings—Class 2000, 3000, and 6000

DIMENSIONS (Inches)

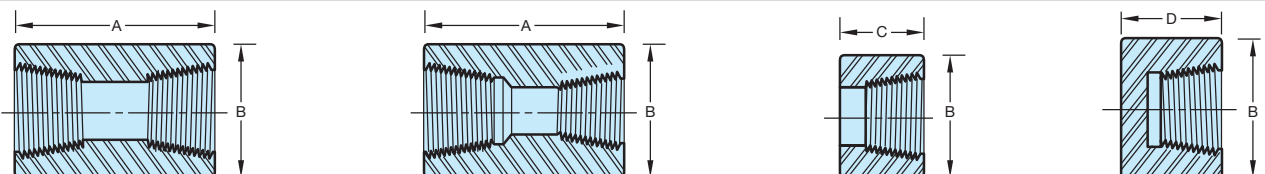
	NOMINAL PIPE SIZE	1/8	1/4	3/8	1/2	3/4	1	1 1/4	1 1/2	2	2 1/2	3	4
		Class 2000	A B F		7/8 29/32 3/4	3 1/32 1 1/16 3/4	1 1/8 1 5/16 1	1 5/16 1 9/16 1 1/8	1 1/2 1 27/32 1 1/4	1 3/4 2 7/32 1 5/16	2 2 1/2 1 3/8	2 3/8 3 1/32 1 11/16	3 3 11/16 2 1/16
Class 3000	A B F H	7/8 29/32 3/4 1 1/4	3 1/32 1 1/16 3/4 1 1/4	1 1/8 1 5/16 1 1 1/2	1 5/16 1 9/16 1 1/8 1 5/8	1 1/2 1 27/32 1 1/4 1 7/8	1 3/4 2 7/32 1 5/16 2 1/4	2 2 1/2 1 3/8 2 5/8	2 3/8 3 1/32 1 11/16 2 15/16	2 1/2 3 11/32 1 3/4 3 5/16	3 1/4 4 2 1/16	3 3/4 4 3/4 2 1/2	4 1/2 6 3 1/8
	J K L	7/8	7/8 1 7/8 2 11/16	1 2 1/8 3	1 1/8 2 9/16 3 9/16	1 3/8 3 4 1/8	1 3/4 3 1/2 4 13/16	2 3 15/16 5 3/8	2 1/8 4 1/4 6 7/16	2 1/2 5 6 5/8			
Class 6000	A B F H	3 1/32 1 1/16 3/4 1 1/4	1 1/8 1 5/16 1 1 1/2	1 5/16 1 9/16 1 1/8 1 5/8	1 1/2 1 27/32 1 1/4 1 7/8	1 3/4 2 7/32 1 5/16 2 1/4	2 2 1/2 1 3/8 2 5/8	2 3/8 3 1/32 1 11/16 2 15/16	2 1/2 3 11/32 1 3/4 3 5/16	3 1/4 4 2 1/16	3 3/4 4 3/4 2 1/2	4 3/16 5 3/4 3 1/8	4 1/2 6 3 1/8
	J K L	7/8	1 2 9/16 3 9/16	1 1/8 3 4 1/8	1 1/8 3 1/2 4 13/16	1 3/4 3 15/16 5 3/8	2 4 3/4 6 7/16	2 1/8 5 6 5/8	2 1/2				



# Threaded Couplings, Reducers and Caps—Class 3000 and 6000

DIMENSIONS (Inches)

Class 3000	NOMINAL PIPE SIZE	1/8	1/4	3/8	1/2	3/4	1	1 1/4	1 1/2	2	2 1/2	3	4
	A	1 1/4	1 3/8	1 1/2	1 7/8	2	2 3/8	2 5/8	3 1/8	3 3/8	3 5/8	4 1/4	4 3/4
	B	3/4	3/4	7/8	1 1/8	1 3/8	1 3/4	2 1/4	2 1/2	3	3 5/8	4 1/4	5 1/2
	C	5/8	11/16	3/4	15/16	1	1 3/16	1 5/16	1 9/16	1 11/16	1 13/16	2 1/8	2 3/8
	D	15/16	1	1	1 1/4	1 7/16	1 5/8	1 3/4	1 3/4	1 7/8	2 3/8	2 9/16	2 11/16
Class 6000	A	1 1/4	1 3/8	1 1/2	1 7/8	2	2 3/8	2 5/8	3 1/8	3 3/8	3 5/8	4 1/4	4 3/4
	B	7/8	1	1 1/4	1 1/2	1 3/4	2 1/4	2 1/2	3	3 5/8	4 1/4	5	6 1/4
	C	5/8	11/16	3/4	15/16	1	1 3/16	1 5/16	1 9/16	1 11/16	1 13/16	2 1/8	2 3/8
	D	1	1 1/16	1 1/16	1 5/16	1 1/2	1 11/16	1 13/16	1 7/8	2	2 1/2	2 11/16	2 15/16



Courtesy Bonney Forge.



**APPENDIX X  
VALVE SPECIFICATIONS**

**CRANE**



No. 438

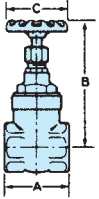
**GATE VALVES  
CLASS 125  
1/4" to 3"**

**Non-Rising Stem  
Screwed Bonnet  
Solid Wedge Disc**

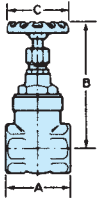
**No. 438, Threaded**

**RATINGS**

Temp. F.	Psi Non-Shock
-20 to 150°	200
200	185
250	170
300	155
350	140
406	125
450	120



## Weights and Dimensions



Valve N.P.S.	Weight—Pounds	Dimensions—Inches		
		A	B	C
1/4	.6	1.64	3.44	1.75
3/8	.6	1.64	3.44	1.75
1/2	1.0	1.90	3.75	2.06
3/4	1.4	2.14	4.38	2.75
1	2.1	2.47	4.88	2.75
1 1/4	3.1	3.08	5.63	3.06
1 1/2	4.2	3.11	6.44	3.63
2	6.2	3.39	7.50	4.50
2 1/2	11.3	4.25	9.06	5.00
3	16.0	4.59	9.69	5.00

"B" dimension is with valve open

**CRANE**



No. 1



No. 2

**GLOBE AND  
ANGLE VALVES  
CLASS 125  
1/8" to 3"**

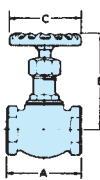
**Screwed Bonnet**

**Globe  
No. 1, Threaded**

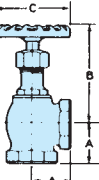
**Angle  
No. 2, Threaded**

**RATINGS**

Temp. F.	Psi Non-Shock
-20 to 150°	200
200	185
250	170
300	155
350	140
406	125
450	120



## Weights and Dimensions



Valve N.P.S.	Weight—Pounds		Dimensions—Inches			
	No. 1	No. 2	A		B	C
			No. 1	No. 2		
1/8	.3	.3	1.44	.75	2.75	1.75
1/4	.4	.4	1.63	.81	3.00	1.75
3/8	.5	.4	1.88	.94	3.25	2.03
1/2	1.0	.8	2.19	1.13	3.75	2.75
3/4	1.4	1.4	2.69	1.38	4.25	2.75
1	2.2	2.0	3.19	1.63	5.00	3.00
1 1/4	3.3	3.0	3.69	1.81	5.50	3.72
1 1/2	4.7	4.5	4.19	2.06	6.25	4.50
2	7.6	7.6	5.13	2.50	7.50	5.00
2 1/2	11.6	—	6.06	—	7.50	5.00
3	19.5	—	7.06	—	9.25	6.00

"B" dimension is with valve open

APPENDIX X (Continued)

CRANE

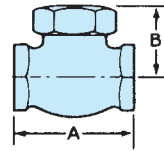


**LIFT CHECK VALVES CLASS 300**  
1/4" to 3"

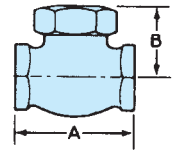
No. 366E Threaded

RATINGS Non-Shock

Temp. F.	Psi 1/4"-2"	Psi 2 1/2"-3"
-20-150°	1000	600
200	920	560
250	830	525
300	740	490
350	650	450
400	560	410
450	480	375
500	390	340
550	300	300



**Weights and Dimensions**

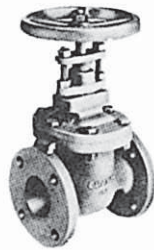


Valve N.P.S.	Weight—Pounds	Dimensions—Inches	
		A	B
1/4	0.4	1.82	1.00
3/8	0.6	2.00	1.12
1/2	0.9	2.50	1.38
3/4	1.5	2.94	1.88
1	2.6	3.50	2.00
1 1/4	4.2	4.06	2.38
1 1/2	5.4	4.62	2.62
2	10.8	5.75	3.25
2 1/2	15.6	6.88	3.88
3	24.0	8.00	4.50

CRANE

**WEDGE GATE VALVES CLASS 125**  
2" to 48"

Non-Rising Stem



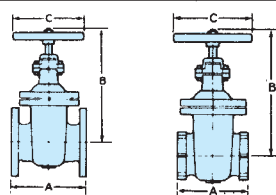
No. 461

**Bronze Trim**  
No. 460, Threaded  
No. 461, Flanged  
**All Iron**  
No. 473, Flanged

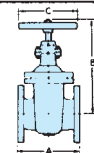
RATINGS

Temp. F.	Psi, Non-Shock		
	2 to 12"	14 to 24"	30 to 48"
-20 to 150°	200	150	150
200	190	135	115
225	180	130	100
250	175	125	85
275	170	120	65
300	165	110	50
325	155	105	
350	150	100	
375	145	*	
400	140	*	
425	130	*	
450	125	*	

\*Use Crane 150-pound steel valves.



**Weights and Dimensions**



Valve N.P.S.	Weight—Pounds			Dimensions—Inches			
	460	461	473	Threaded		Flanged	
				A	A	B	C
2	25	30	30	5.38	7.00	11.31	8.0
2 1/2	31	40	40	6.62	7.50	12.40	8.0
3	44	56	56	7.00	8.00	13.25	8.0
4	71	90	90	8.00	9.00	16.31	10.0
5	—	126	—	—	10.00	18.00	10.0
6	—	152	152	—	10.50	20.69	12.0
8	—	260	260	—	11.50	24.12	14.0

Valve N.P.S.	Weight—Pounds	Dimensions—Inches		
		A	B	C
10	475	13.00	33.00	20.0
12	680	14.00	36.50	20.0
14	850	15.00	40.50	20.0
16	1280	16.00	47.25	22.0
18	1480	17.00	50.25	24.0
20	1840	18.00	54.75	24.0
24	2860	20.00	65.00	30.0
30	On Request	24.00	76.00	36.0
36	On Request	28.00	85.00	42.0
42	On Request	33.00	106.00	42.0
48	On Request	36.00	111.25	42.0

APPENDIX X (Continued)

CRANE



No. 353

**GLOBE AND  
ANGLE  
VALVES  
CLASS 125  
2" to 10"**

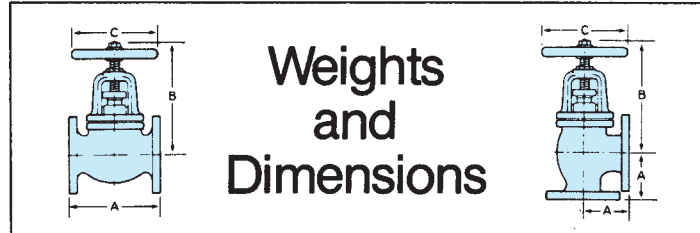
Outside Screw & Yoke  
Bronze Trim

Globe  
No. 351, Flanged

Angle  
No. 353, Flanged

RATINGS

Temp. F.	Psi, Non-Shock	Temp. F.	Psi Non-Shock
-20 to 150°	200	325	155
200	190	350	150
225	180	375	145
250	175	400	140
275	170	425	130
300	165	450	125



**Weights  
and  
Dimensions**

Valve N.P.S.	Weight—Pounds		Dimensions—Inches				
	351	353	351	353	351	353	C
			A	A	B	B	
2	34	32	8.00	4.00	11.12	11.00	8.00
2½	40	38	8.50	4.25	11.50	11.50	8.00
3	57	54	9.50	4.75	13.25	12.75	9.00
4	95	88	11.50	5.75	15.50	15.00	10.00
5	126	—	13.00	—	17.50	—	10.00
6	176	158	14.00	7.00	19.50	19.50	12.00
8	344	—	19.50	—	25.00	—	16.00
10	570	—	24.50	—	30.50	—	18.00

"B" dimension is with valve open.

CRANE



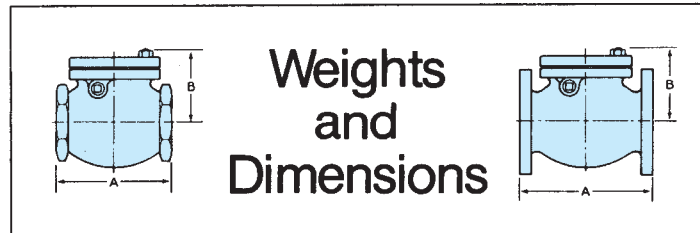
No. 373

**SWING CHECK  
VALVES  
CLASS 125  
2" to 24"**

Bolted Cap

Bronze Trim  
No. 372, Threaded  
No. 373, Flanged

All Iron  
No. 373½, Flanged



**Weights  
and  
Dimensions**

Valve N.P.S.	Weight—Pounds			Dimensions—Inches		
	372	373	373½	Threaded A	Flanged A	B
2	18	25	25	6.12	8.00	4.50
2½	22	34	34	7.25	8.50	5.38
3	29	44	44	8.00	9.50	5.88
4	54	75	75	9.25	11.50	6.62
5	—	103	—	—	13.00	7.75
6	—	127	127	—	14.00	8.25
8	—	230	230	—	19.50	10.25
10	—	510	510	—	24.50	11.60
12	—	695	695	—	27.50	13.60
14	—	875	—	—	31.00	15.75
16	—	1410	—	—	34.00	17.00
18	—	1540	—	—	38.50	17.40
20	—	1940	—	—	38.50	19.50
24	—	3000	—	—	51.00	20.50

RATINGS

Temp. F.	Psi, Non-Shock	
	Sizes 2"-12"	Sizes 14"-24"
-20 to 150°	200	150
200	190	135
225	180	130
250	175	125
275	170	120
300	165	110
325	155	105
350	150	100
375	145	—
400	140	—
425	130	—
450	125	—

Courtesy Crane Co.

TABLE 32 WROUGHT STEEL PIPE<sup>a</sup> AND TAPER PIPE THREADS<sup>b</sup>—  
AMERICAN NATIONAL STANDARD

All dimensions are in inches except those in last two columns.

Nominal Pipe Size	D Outside Diameter of Pipe	L <sub>c</sub> Normal Engagement by Hand Between External and Internal Threads	L <sub>e</sub> Length of Effective Thread	Nominal Wall Thickness										Length of Pipe, Feet, per Square Foot External Surface <sup>d</sup>	Length of Standard Weight Pipe, Feet, Containing 1 cu. ft. <sup>d</sup>										
				10		20		30		40		60 <sup>c</sup>				80		100		120		140		160	
				Sched.	Sched.	Sched.	Sched.	Sched.	Sched.	Sched.	Sched.	Sched.	Sched.			Sched.	Sched.	Sched.	Sched.	Sched.	Sched.	Sched.	Sched.	Sched.	Sched.
1/8	.405	27.0	.1615	.2639	...	...	...	...	.068	...	...	...	.095	...	...	...	...	...	...	...	...	...	9.431	2,533.800	
1/4	.540	18	.2278	.4018	...	...	...	...	.088	...	...	...	.119	...	...	...	...	...	...	...	...	...	7.073	1,383.8	
3/8	.675	18	.240	.4078	...	...	...	...	.091	...	...	...	.126	...	...	...	...	...	...	...	...	...	5.658	754.36	
1/2	.840	14	.320	.5337	...	...	...	...	.109	...	...	...	.147	...	...	...	...	...	...	...	...	...	4.547	473.91	
3/4	1.050	14	.339	.5457	...	...	...	...	.113	...	...	...	.154	...	...	...	...	...	...	...	...	...	3.637	270.03	
1	1.315	11.5	.400	.6828	...	...	...	...	.133	...	...	...	.179	...	...	...	...	...	...	...	...	...	2.904	166.62	
1 1/4	1.660	11.5	.420	.7068	...	...	...	...	.140	...	...	...	.191	...	...	...	...	...	...	...	...	...	2.301	96.275	
1 1/2	1.900	11.5	.420	.7235	...	...	...	...	.145	...	...	...	.200	...	...	...	...	...	...	...	...	...	2.010	70.733	
2	2.375	11.5	.436	.7565	...	...	...	...	.154	...	...	...	.218	...	...	...	...	...	...	...	...	...	1.608	42.913	
2 1/2	2.875	8	.682	1.1375	...	...	...	...	.203	...	...	...	.276	...	...	...	...	...	...	...	...	...	1.328	30.077	
3	3.500	8	.766	1.2000	...	...	...	...	.216	...	...	...	.300	...	...	...	...	...	...	...	...	...	1.091	19.479	
3 1/2	4.000	8	.821	1.2500	...	...	...	...	.226	...	...	...	.318	...	...	...	...	...	...	...	...	...	.954	14.565	
4	4.500	8	.844	1.3000	...	...	...	...	.237	...	...	...	.337	...	...	...	...	...	...	...	...	...	.848	11.312	
5	5.563	8	.937	1.4063	...	...	...	...	.258	...	...	...	.375	...	...	...	...	...	...	...	...	...	.686	7.199	
6	6.625	8	.958	1.5125	...	...	...	...	.280	...	...	...	.432	...	...	...	...	...	...	...	...	...	.576	4.984	
8	8.625	8	1.063	1.7125	...	...	...	...	.322	.277	.250	.277	.406	.500	.594	.719	.812	.906	.443	.443	.443	.443	.443	2.878	
10	10.750	8	1.210	1.9250	...	...	...	...	.365	.307	.250	.307	.500	.594	.719	.844	1.000	1.125	.355	.355	.355	.355	.355	1.826	
12	12.750	8	1.360	2.1250	...	...	...	...	.406	.330	.250	.330	.562	.688	.844	1.000	1.125	1.312	.299	.299	.299	.299	.299	1.273	
14 OD	14.000	8	1.562	2.2500	.250	.312	.375	.438	.500	.375	.312	.375	.594	.750	.938	1.094	1.250	1.406	.273	.273	.273	.273	.273	1.065	
16 OD	16.000	8	1.812	2.4500	.250	.312	.375	.438	.500	.375	.312	.375	.656	.844	1.031	1.219	1.438	1.594	.239	.239	.239	.239	.239	.815	
18 OD	18.000	8	2.000	2.6500	.250	.312	.375	.438	.562	.500	.312	.438	.750	.938	1.156	1.375	1.562	1.781	.212	.212	.212	.212	.212	.644	
20 OD	20.000	8	2.125	2.8500	.250	.375	.500	.594	.688	.594	.375	.500	.812	1.031	1.281	1.500	1.750	1.969	.191	.191	.191	.191	.191	.518	
24 OD	24.000	8	2.375	3.2500	.250	.375	.562	.688	.969	1.219	1.531	1.812	2.062	2.344	2.622	2.906	3.190	3.474	.159	.159	.159	.159	.159	.358	

<sup>a</sup> ANSI/ASME B36.10M–1995.

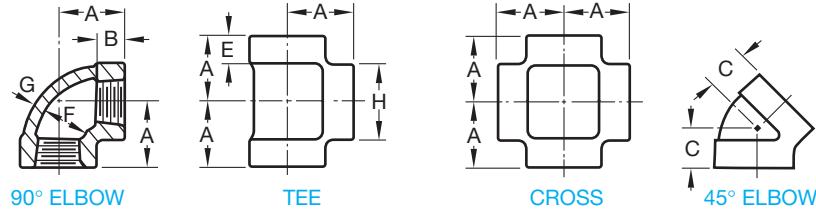
<sup>b</sup> ANSI/ASME B1.20.1–1983 (R1992).

<sup>c</sup> Refer to 813.22 and Fig. 13.20.

<sup>d</sup> Calculated values for Schedule 40 pipe.

APPENDIX X (Continued)

**TABLE 33 CAST IRON PIPE SCREWED FITTINGS,<sup>a</sup>  
125 LB—AMERICAN NATIONAL STANDARD**



DIMENSIONS OF 90° AND 45° ELBOWS, TEES, AND CROSSES (STRAIGHT SIZES)

All dimensions given in inches.

Fittings that have right- and left-hand threads shall have four or more ribs or the letter L cast on the band at end with left-hand thread.

Nominal Pipe Size	Center to End, Elbows, Tees, and Crosses A	Center to End, 45° Elbows C	Length of Thread, Min. B	Width of Band, Min. E	Inside Diameter of Fitting F		Metal Thickness G	Diameter of Band, Min. H
					Max.	Min.		
1/4	.81	.73	.32	.38	.58	.54	.11	.93
3/8	.95	.80	.36	.44	.72	.67	.12	1.12
1/2	1.12	.88	.43	.50	.90	.84	.13	1.34
3/4	1.31	.98	.50	.56	1.11	1.05	.15	1.63
1	1.50	1.12	.58	.62	1.38	1.31	.17	1.95
1 1/4	1.75	1.29	.67	.69	1.73	1.66	.18	2.39
1 1/2	1.94	1.43	.70	.75	1.97	1.90	.20	2.68
2	2.25	1.68	.75	.84	2.44	2.37	.22	3.28
2 1/2	2.70	1.95	.92	.94	2.97	2.87	.24	3.86
3	3.08	2.17	.98	1.00	3.60	3.50	.26	4.62
3 1/2	3.42	2.39	1.03	1.06	4.10	4.00	.28	5.20
4	3.79	2.61	1.08	1.12	4.60	4.50	.31	5.79
5	4.50	3.05	1.18	1.18	5.66	5.56	.38	7.05
6	5.13	3.46	1.28	1.28	6.72	6.62	.43	8.28
8	6.56	4.28	1.47	1.47	8.72	8.62	.55	10.63
10	8.08 <sup>b</sup>	5.16	1.68	1.68	10.85	10.75	.69	13.12
12	9.50 <sup>b</sup>	5.97	1.88	1.88	12.85	12.75	.80	15.47

<sup>a</sup> From ANSI/ASME B16.4-1992.

<sup>b</sup> This applies to elbows and tees only.

## APPENDIX Y

### PVC PIPE DIMENSIONS IN INCHES

PVC PIPE DIMENSIONS IN INCHES					
Schedule 40 Dimensions					
Nominal Pipe Size	O.D.	Average I.D.	Minimum Wall Thickness	Nominal Weight/Ft.	Maximum Water Pressure PSI
1/8"	0.405	0.249	0.068	0.051	810
1/4"	0.540	0.344	0.088	0.086	780
3/8"	0.675	0.473	0.091	0.115	620
1/2"	0.840	0.602	0.109	0.170	600
3/4"	1.050	0.804	0.113	0.226	480
1"	1.315	1.029	0.133	0.333	450
1-1/4"	1.660	1.360	0.140	0.450	370
1-1/2"	1.900	1.590	0.145	0.537	330
2"	2.375	2.047	0.154	0.720	280
2-1/2"	2.875	2.445	0.203	1.136	300
3"	3.500	3.042	0.216	1.488	260
3-1/2"	4.000	3.521	0.226	1.789	240
4"	4.500	3.998	0.237	2.118	220
5"	5.563	5.016	0.258	2.874	190
6"	6.625	6.031	0.280	3.733	180
8"	8.625	7.942	0.322	5.619	160
10"	10.750	9.976	0.365	7.966	140
12"	12.750	11.889	0.406	10.534	130
14"	14.000	13.073	0.437	12.462	130
16"	16.000	14.940	0.500	16.286	130
18"	18.000	16.809	0.562	20.587	130
20"	20.000	18.743	0.593	24.183	120
24"	24.000	22.544	0.687	33.652	120

Courtesy Harvel Plastics, Inc. and ASTM.

## APPENDIX Y (Continued)

PVC PIPE DIMENSIONS IN INCHES (CONTINUED)					
Schedule 80 Dimensions					
Nominal Pipe Size	O.D.	Average I.D.	Minimum Wall Thickness	Nominal Weight/Ft.	Maximum Water Pressure PSI
1/8"	0.405	0.195	0.095	0.063	1230
1/4"	0.540	0.282	0.119	0.105	1130
3/8"	0.675	0.403	0.126	0.146	920
1/2"	0.840	0.526	0.147	0.213	850
3/4"	1.050	0.722	0.154	0.289	690
1"	1.315	0.936	0.179	0.424	630
1-1/4"	1.660	1.255	0.191	0.586	520
1-1/2"	1.900	1.476	0.200	0.711	470
2"	2.375	1.913	0.218	0.984	400
2-1/2"	2.875	2.290	0.276	1.500	420
3"	3.500	2.864	0.300	2.010	370
3-1/2"	4.000	3.326	0.318	2.452	350
4"	4.500	3.786	0.337	2.938	320
5"	5.563	4.768	0.375	4.078	290
6"	6.625	5.709	0.432	5.610	280
8"	8.625	7.565	0.500	8.522	250
10"	10.750	9.493	0.593	12.635	230
12"	12.750	11.294	0.687	17.384	230
14"	14.000	12.410	0.750	20.852	220
16"	16.000	14.213	0.843	26.810	220
18"	18.000	16.014	0.937	33.544	220
20"	20.000	17.814	1.031	41.047	220
24"	24.000	21.418	1.218	58.233	210

## APPENDIX Z RECTANGULAR AND ROUND HVAC DUCT SIZES

This chart provides rectangular and round duct sizes for air flows between 100 and 50,000 cfm.

CFM (Cubic Feet per Minute)	Equivalent Rectangular Duct Sizes (Inches)	Equivalent Diameter Round Duct Sizes (Inches)	CFM (Cubic Feet per Minute)	Equivalent Rectangular Duct Sizes (Inches)	Equivalent Diameter Round Duct Sizes (Inches)
100	3 × 4	4	6000	14 × 20	19
200	3 × 7 4 × 5	5		15 × 18	
300	4 × 7 5 × 6	6	7000	12 × 26 16 × 20	20
400	4 × 9 5 × 7 6 × 6	7	8000	12 × 30 14 × 25	21
500	6 × 7	8	9000	12 × 34 15 × 25	22
750	5 × 12 6 × 10 7 × 8	9	10000	12 × 36 16 × 25 20 × 20	23
1000	7 × 10 8 × 9		12500	12 × 45 16 × 30 20 × 24	
1250	8 × 10 9 × 9	10	15000	16 × 36 18 × 30 23 × 25	26
1500	8 × 12 10 × 10	12	17500	16 × 40 20 × 32 25 × 25	28
1750	8 × 14 9 × 12 10 × 11	12	20000	16 × 45 20 × 35 25 × 28	30
2000	8 × 15 10 × 12	12	25000	16 × 55 20 × 43 25 × 38	32
2500	10 × 14 12 × 12	14	30000	20 × 50 30 × 32	34
3000	12 × 14	14	35000	20 × 55 30 × 35	36
3500	12 × 15	15	40000	25 × 48 30 × 40	38
4000	10 × 22 14 × 15	16	45000	25 × 25 32 × 40	40
4500	12 × 19 14 × 16	17	50000	32 × 45	42
5000	10 × 25 12 × 20 15 × 16	17		35 × 40	



**APPENDIX AA**  
**SPUR AND HELICAL GEAR DATA**

	Spur Gear Data	Suggested Number of Decimal Places
BASIC SPECIFICATIONS	NUMBER OF TEETH	
	DIAMETRAL PITCH	XX.XXXX
	PRESSURE ANGLE	XX°
	STANDARD PITCH DIAMETER	X.XXXX
	TOOTH FORM	
	ADDENDUM	.XXXX
	WHOLE DEPTH	.XXXX
	CALC. CIR. TOOTH THICKNESS ON STD. PITCH CIRCLE	.XXXX MAX. .XXXX MIN.
MANUFACTURING AND INSPECTION	GEAR TESTING RADIUS	X.XXXX MAX. X.XXXX MIN.
	AGMA QUALITY NUMBER	
	MAX. TOTAL COMPOSITE TOLERANCE	.XXXX
	MAX. TOOTH-TO-TOOTH COMPOSITE TOLERANCE	.XXXX
	MASTER GEAR SPECIFICATIONS	
	TESTING PRESSURE (OUNCES)	XX
	DIAMETER OF MEASURING PIN	.XXXX
	MEASUREMENT OVER TWO PINS (FOR SETUP ONLY)	X.XXXX MAX. X.XXXX MIN.
	OUTSIDE DIAMETER	X.XXX <sup>+.000</sup> - .00X
	MAX. ROOT DIAMETER	X.XXX
ENGINEERING REFERENCES	MATING GEAR PART NUMBER	
	NUMBER OF TEETH IN MATING GEAR	
	OPERATING CENTER DISTANCE	X.XXXX MAX. X.XXXX MIN.

	Helical Data	Suggested Number of Decimal Places	
BASIC SPECIFICATIONS	NUMBER OF TEETH		
	DIAMETRAL PITCH	XX.XXXX	
	NORMAL DIAMETRAL PITCH	XX.XXXX	
	NORMAL PRESSURE ANGLE	XX°	
	HELIX ANGLE	XX.XXXX°	
	HAND OF HELIX	L.H. OR R.H.	
	STANDARD PITCH DIAMETER	X.XXXX	
	TOOTH FORM		
	ADDENDUM	.XXXX	
	WHOLE DEPTH	.XXXX	
	CALC. NORMAL CIR. TOOTH THICKNESS ON STD. PITCH CIRCLE	.XXXX MAX. .XXXX MIN.	
	MANUFACTURING AND INSPECTION	MANUFACTURING AND INSPECTION	
		GEAR TESTING RADIUS	X.XXXX MAX. X.XXXX MIN.
		AGMA QUALITY NUMBER	
MAX. TOTAL COMPOSITE TOLERANCE		.XXXX	
MAX. TOOTH-TO-TOOTH COMPOSITE TOLERANCE		.XXXX	
MASTER GEAR SPECIFICATIONS			
TESTING PRESSURE (OUNCES)		XX	
DIAMETER OF MEASURING PIN		.XXXX	
MEASUREMENT OVER TWO PINS (FOR SETUP ONLY)		X.XXXX MAX. X.XXXX MIN.	
LEAD			
OUTSIDE DIAMETER	X.XXX <sup>+.000</sup> - .00X		
MAX. ROOT DIAMETER	X.XXXX		
ENGINEERING REFERENCES	ENGINEERING REFERENCES		
	MATING GEAR PART NUMBER		
	NUMBER OF TEETH IN MATING GEAR		
	OPERATING CENTER DISTANCE	X.XXXX MAX. X.XXXX MIN.	

## APPENDIX BB CADD DRAWING SHEET SIZES, SETTINGS, AND SCALE FACTORS

CADD DRAWING SHEET SIZES, SETTINGS, AND SCALE FACTORS			
Prototype Drawing Sheet Parameters			
Drawing Scale	D-size (34" × 22") Drawing Limits	C-size (22" × 17") Drawing Limits	B-size (17" × 11") Drawing Limits
1" = 1"	34,22	22,17	17,11
1/2" = 1"	68,44	44,34	34,22
1/4" = 1"	136,88	88,68	68,44
1/8" = 1"	272,176	176,136	136,88
1" = 1'-0"	408,264	264,204	204,132
3/4" = 1'-0"	544,352	352,272	272,176
1/2" = 1'-0"	816,528	528,408	408,264
3/8" = 1'-0"	1088,704	704,544	544,352
1/4" = 1'-0"	1632,1056	1056,816	816,528
3/16" = 1'-0"	2176,1408	1408,1088	1088,704
1/8" = 1'-0"	3264,2112	2112,1632	1632,1056
3/32" = 1'-0"	4352,2816	2816,2176	2176,1408
1/16" = 1'-0"	6528,4224	4224,3264	3264,2112

Prototype Drawing Scale Parameters			
Drawing Scale	Dimension Scale (DIMSCALE)	Linetype Scale (LTSCALE)	Inversion Scale of Border & Parts List Blocks
1" = 1"	1	.5	1 = 1
1/2" = 1"	2	1	1 = 2
1/4" = 1"	4	2	1 = 4
1/8" = 1"	8	4	1 = 8
1" = 1'-0"	12	6	1 = 12
3/4" = 1'-0"	16	8	1 = 16
1/2" = 1'-0"	24	12	1 = 24
3/8" = 1'-0"	32	16	1 = 32
1/4" = 1'-0"	48	24	1 = 48
3/16" = 1'-0"	64	32	1 = 64
1/8" = 1'-0"	96	48	1 = 96
3/32" = 1'-0"	128	64	1 = 128
1/16" = 1'-0"	192	96	1 = 192

APPENDIX BB (Continued)

CADD DRAWING SHEET SIZES, SETTINGS, AND SCALE FACTORS								
Architectural Sheet Size and Settings								
Paper Size (in.)	Approx. Drawing Area	Scale	Actual Sheet Limits	Approx. Drawing Limits	Text Height		Scale Factor	Ltscale
					1/8"	1/4"		
A 12 × 9	10 × 7.5	1" = 1'-0" 1/2" = 1'-0" 1/4" = 1'-0" 1/8" = 1'-0"	12' × 9' 24' × 18' 48' × 36' 96' × 72'	10' × 7.5' 20' × 15' 40' × 30' 80' × 60'	1.5 3.0 6.0 12.0	3.0 6.0 12.0 24.0	12 24 48 96	6 12 24 48
B 18 × 12	16 × 11	1" = 1'-0" 1/2" = 1'-0" 1/4" = 1'-0" 1/8" = 1'-0"	18' × 12' 36' × 24' 72' × 48' 144' × 96'	16' × 11' 32' × 20' 64' × 40' 128' × 80'				
C 24 × 18	22 × 16	1" = 1'-0" 1/2" = 1'-0" 1/4" = 1'-0" 1/8" = 1'-0"	24' × 18' 48' × 36' 96' × 72' 192' × 144'	22' × 16' 44' × 32' 88' × 64' 176' × 28'				
D 36 × 24	34 × 22	1" = 1'-0" 1/2" = 1'-0" 1/4" = 1'-0" 1/8" = 1'-0"	36' × 24' 72' × 48' 144' × 96' 288' × 192'	34' × 22' 68' × 44' 136' × 88' 272' × 176'				
E 48 × 36	46 × 34	1" = 1'-0" 1/2" = 1'-0" 1/4" = 1'-0" 1/8" = 1'-0"	48' × 36' 96' × 72' 192' × 144' 384' × 288'	46' × 34' 92' × 68' 184' × 136' 368' × 272'				

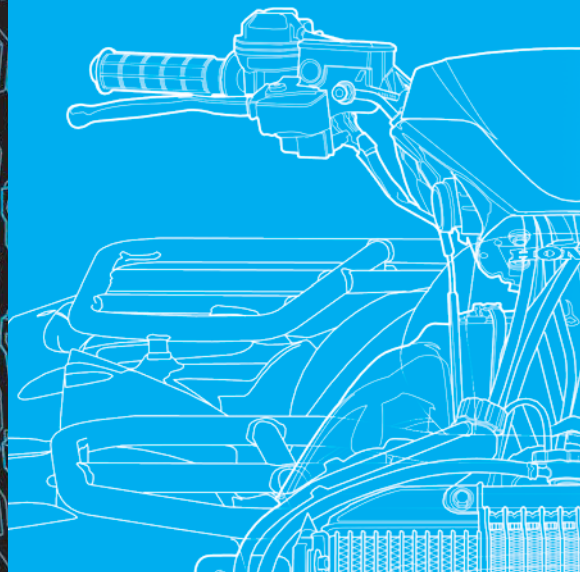
Mechanical Sheet Size and Settings								
Paper Size (in.)	Approx. Drawing Area	Scale	Actual Sheet Limits	Approx. Drawing Limits	Text Height		Scale Factor	Ltscale
					1/8"	1/4"		
A 11 × 8.5	9 × 7	2" = 1" 3/4" = 1" 1/2" = 1" 1/4" = 1"	5.5 × 4.25 14.67 × 11.33 22 × 17 44 × 34	4.5" × 3.5" 12" × 9.33" 18" × 14" 36" × 28"	.0625 .167 .25 .5	.125 .33 .5 1.0	.5 1.33 2 4	.25 .67 1 2
B 17 × 11	15 × 10	2" = 1" 3/4" = 1" 1/2" = 1" 1/4" = 1"	8.5 × 5.5 22.67 × 14.67 34 × 22 68 × 44	7.5" × 5" 20" × 13.33" 30" × 20" 60" × 40"				
C 22 × 17	20 × 15	2" = 1" 3/4" = 1" 1/2" = 1" 1/4" = 1"	11 × 8.5 29.33 × 14.67 44 × 34 88 × 68	10" × 7.5" 26.67" × 20" 40" × 30" 80" × 60"				
D 34 × 22	32 × 20	2" = 1" 3/4" = 1" 1/2" = 1" 1/4" = 1"	17 × 11 45.33 × 29.33 68 × 44 136 × 88	16" × 10" 42.67" × 26.67" 64" × 40" 128" × 80"				
E 44 × 34	42 × 32	2" = 1" 3/4" = 1" 1/2" = 1" 1/4" = 1"	22 × 17 58.67 × 45.33 88 × 68 176 × 136	21" × 16" 56" × 42.67" 84" × 64" 168" × 128"				

## APPENDIX BB (Continued)

CADD DRAWING SHEET SIZES, SETTINGS, AND SCALE FACTORS								
Civil Sheet Size and Settings								
Paper Size (in.)	Approx. Drawing Area	Scale	Actual Sheet Limits	Approx. Drawing Limits	Text Height		Scale Factor	Ltscale
					1/8"	1/4"		
A 11 × 8.5	9 × 7	1" = 10' 1" = 20' 1" = 30' 1" = 50'	110' × 85' 220' × 170' 330' × 255' 550' × 425"	90' × 70' 180' × 140' 270' × 210' 450' × 350'	15 30 45 75	30 60 90 150	120 240 360 600	60 120 180 300
B 17 × 11	15 × 10	1" = 10' 1" = 20' 1" = 30' 1" = 50'	170' × 110' 340' × 220' 510' × 330' 850' × 550'	150' × 100' 300' × 200' 450' × 300' 750' × 500'				
C 22 × 17	20 × 15	1" = 10' 1" = 20' 1" = 30' 1" = 50'	220' × 170' 440' × 340' 660' × 510' 1100' × 850'	200' × 150' 400' × 300' 600' × 450' 1000' × 750'				
D 34 × 22	32 × 20	1" = 10' 1" = 20' 1" = 30' 1" = 50'	340' × 220' 680' × 440' 1020' × 660' 1700' × 1100'	320' × 200' 640' × 400' 960' × 600' 1600' × 1000'				
E 44 × 34	42 × 32	1" = 10' 1" = 20' 1" = 30' 1" = 50'	440' × 340' 880' × 680' 1320' × 1020' 2200' × 1700'	420' × 320' 840' × 640' 1260' × 960' 2100' × 1600'				



# GLOSSARY



## A

**Acme** A thread system used especially for feed mechanisms.

**Acoustical liner** An HVAC liner placed inside a duct to help reduce the sound caused by air moving through the duct.

**Active device** An electronic component that contains voltage or current sources, such as a transistor and integrated circuit.

**Actual local size** Any cross-sectional measurement at any two adjacent points.

**Actual mating size** The smallest distance between two parallel planes within which the actual surface features are contained.

**Actual produced size** The measured size after production.

**Actual size** The measured size of a feature or part after manufacturing; includes the actual local size and the actual mating size.

**Adaptive parts** In CADD assemblies, parts that modify automatically if other parts change.

**Addendum (spur gear)** The radial distance from the pitch circle to the top of the tooth.

**Addendum angle (bevel gear)** The angle subtended by the addendum.

**Additive process** Process that takes place on a board that is covered with a chemically etched material that will accept copper.

**Adhesion** Force that holds together the molecules of unlike substances when the surfaces come in contact.

**Adjacent views** Two adjoining views aligned by projection.

**Advanced research** Research used to determine if there are areas of technology currently not utilized.

**AGMA quality number** Classification of gears based on the accuracy of the maximum tooth-to-tooth and total composite tolerances allowed.

**Agonic line** Line of zero declination.

**Air-supply registers** See Diffusers.

**Air-to-air heat exchanger** Heat-recovery ventilation device that pulls stale, polluted, warm air from the living or working space through a duct system and transfers the heat in that air to the fresh cold air being pulled into the structure.

**Aligned dimensioning** Format that requires that all numerals, figures, and notes be aligned with the dimension lines so they can be read from the bottom for horizontal dimensions and from the right side for vertical dimensions.

**Aligned section** The cutting plane is staggered to pass through offset features of an object.

**Alignment charts** Charts designed to graphically solve mathematical equation values using three or more scaled lines.

**Allowance** The tightest possible fit between two mating parts.

**Alloys** A mixture of two or more metals.

**Alumina** Any of several forms of aluminum oxide, which occurs naturally.

**Alumina refining process** Process that extracts alumina from bauxite, an aluminum ore.

**Aluminum** Corrosion-resistant, lightweight, easily cast metal that conducts heat and electricity, may be easily extruded, and is very malleable.

**American National Standard taper pipe threads** Standard threads used on pipes and pipe fittings.

**American National threads** Threads similar to Unified threads but with flat roots.

**Amplifier (AMP)** Device that allows an input signal to control power; capable of having an output signal greater than the input signal.

**Analysis** Examination and evaluation of important information to select the best course of action from various alternatives.

**Anchor bolt** Bolt embedded in concrete and used to hold structural members in place.

**Angle of projection block** Specification for how to interpret a drawing according to the method of view projection.

**Angle of repose** Run-to-rise ratio of highway cut and fill.

**Angle valve** A special type of globe valve that creates a 90° direction change in the pipe.

**Angles** Corner formed by intersection of two lines; sized in degrees (°). Components of a degree are minutes (') and seconds ("). There are 60 minutes (') in 1 degree and 60 seconds (") in 1 minute: 1° = 60', 1' = 60".

**Angles (structural)** Structural steel components that have an L shape.

**Angular contact ball bearings** Bearings that support a heavy thrust load and a moderate radial load.

**Angular dimension line** Dimension line drawn as an arc with the center of the arc from the vertex of the angle.

**Angularity** Condition of a surface, center plane, or axis at any specified angle from a datum plane or axis. An angularity geometric tolerance zone is established by two parallel planes or cylindrical zones at any specified basic angle other than 90° to a datum plane, a pair of datum planes, or an axis.

**Animation** Process of making drawings or models move and change according to a sequence of predefined images.

**Annealing** Softening of steel under certain heating and cooling conditions and techniques.

**Apparent intersection** Condition in which lines or planes *look* as if they may be intersecting but may not actually be intersecting.

**Application block** Optional information block that contains information such as next assembly; used for drawings of a detail part or assembly of a component of a larger assembly.

**Application list (AL) number** System of words used to name things in a discipline, the list of names, features or terms, and part and assembly designation data presented in a separate list.

**Arc** Part of the circumference of a circle; can be identified by a radius, an angle, or a length.

**Archive** To store something permanently for safekeeping.

**Arrow method** An alternate practice for providing removed and sectional views.

**Arrowheads** Used to cap dimension lines and leader line ends.

**As-built drawings** Drawings developed from existing items or products.

**Aspect ratio** Relationship between the length and width of a duct.

**Assembly** Grouping of one or more design components. Components can include part models and subassemblies. Also referred to as an *assembly drawing*.

**Assembly constraints** Constraints that establish geometric relationships and positions between components, define the desired movement between components, and identify relationships between the transitioning path of a fixed component and a component moving along the path. *See also* Mates.

**Assembly drawing** Mechanical drafting drawing that shows how the parts of a product go together.

**Assembly drawing (printed circuit board)** Complete engineering drawing, including components, assembly, and fastening or soldering specifications, and a parts list or bill of materials.

**Assembly files** Files used to create assemblies and subassemblies and to reference multiple part and subassembly files.

**Associative dimension** A CADD dimension associated with an object. The dimension value updates automatically when the object changes.

**Attribute** *See* Text (CADD).

**Automatic pencil** Pencil with a lead chamber that, at the push of a button or tab, advances lead from the chamber to the writing tip when a new piece of lead is needed.

**Auxiliary view** View that is required when a surface is not parallel to one of the principal planes of projection; the auxiliary projection plane

is parallel to the inclined surface so that the surface may be viewed in its true size and shape.

**Axis** (1) The thread axis of a screw thread is the centerline of the cylindrical thread shape. (2) Centerline of a cylindrical feature.

**Azimuth** Clockwise measurement of the angle of a line measured from the north or its reference meridian.

## B

**Back solve** Provided force data, software calculates design criteria such as shaft size, hole size, and material.

**Backsight** In surveying, the rod reading behind the level toward the point of beginning.

**Backward compatible** When new parts function in previously manufactured versions of products.

**Ball bearing** Friction reducer where balls roll in two grooved rings.

**Ball valve** Sealing mechanism inside a ball requiring one quarter turn to function.

**Balloon** Circle placed on a drawing with a part identification number inside the circle. Each balloon is connected to its related part with a leader line. The balloon part identification number correlates to the same number identifying the part in the parts list. The parts list identifies every part in the assembly.

**Band saw** Saw used to cut a wide variety of materials.

**Bars (structural)** Smallest structural steel products; manufactured in round, square, rectangular, flat, or hexagonal cross sections.

**Base circle (cam)** Smallest circle tangent to the cam follower at the bottom of displacement.

**Base circle diameter (spur gear)** Diameter of a circle from which the involute tooth is generated.

**Baseline dimensioning** Dimensioning system in which each dimension originates from a common surface, plane, or axis.

**Basic dimension** Numerical value used to describe the theoretically exact size, profile, orientation, or location of a feature or datum target. It is the basis from which permissible variations are established by tolerances on other dimensions, in notes, or in feature control frames.

**Basic size** *See* Specified dimension.

**Bead chains** Commonly used chains for control mechanisms for light-duty, low-power applications.

**Beams** Horizontal structural members used to support roof or wall loads.

**Bearing (civil)** Measurement of the angle of a line measured from either the north or south meridian (whichever is nearer).

**Bearing (mechanical)** Mechanical device that reduces friction between two surfaces.

**Bearing angle** Angle of a line that is always 90° or less and is identified either from the north or the south.

**Bearing codes** Codes used by bearing manufacturers as a coding systems for the identification and ordering of different bearing products.

**Bearing of a line** Angular relationship of the horizontal projection of the line relative to the compass; expressed in degrees.

**Bearing pressure (structural)** Normally, the number of pounds per square foot of pressure the soil is engineered to support.

**Bearing seal** A rubber, felt, or plastic seal on the outer and inner ring of a bearing. Generally, it is filled with a special lubricant by the manufacturer.

**Bearing shield** Metal plate on one or both sides of a bearing; serves to retain the lubricant and keep the bearing clean.

**Bell and spigot** Pipe connection in which one end of a piece of pipe has a bell-shaped opening and the other end is tapered or notched to fit into the bell.

**Bell crank** Link pivoted near the center that oscillates through an angle.

**Belt** Used to transmit power from one shaft to another smoothly, quietly, and inexpensively.

**Belt drive** Transmits power between rotating shafts.

**Belt drive ratio** Relationship between the drive and driven pulleys.

**Belt velocity** Speed a belt travels in feet per minute (fpm) for a given application.

**Bench mark (civil)** Name for a known point with a known elevation that is part of the geodetic control system; also called **monument**.

**Benchmarking** Engineering design analysis of a product; the starting point establishes the benchmark. When redesigning or making desired changes, one reanalyzes to determine the difference from the benchmark condition to the revised condition.

**Bend (or bent)** Metal being formed using a stake, brake, folder, die, roller, or similar tool.

**Bend allowance** Amount of extra material needed for a bend to compensate for compression during the bending process.

**Bending** Accomplished by forming metal between dies and changing it from flat stock to a desired contour.

**Bend relief** Typically added to a sheet metal part to relieve stress or tearing that occurs when a portion of a piece of material is bent.

**Bend tangent line** Line where flat surface of a part is tangent to the bend radius.

**Bend transition (sheet metal)** Change made between the adjacent surfaces at a bend when the edge of one surface extends beyond the edge of the other surface.

**Bevel** Term used to denote the slope of beams (as in structural engineering).

**Bevel gear** Used to transmit power between intersecting shafts; takes the shape of a frustum of a cone.

**Bevel groove weld** Created when one piece is square and the other piece has a beveled surface.

**Bias** Voltage applied to a circuit element to control the mode of operation.

**Bidding requirements** Construction documents issued to bidders for the purpose of providing construction bids.

**Bilateral tolerance** Tolerance in which variation is permitted in both directions from the specified dimension.

**Bill of materials (BOM)** In piping, indicates exact size and specifications for each fitting. *See also* Parts list.

**Billet (piping)** Section of steel used for rolling into bars, pipe, and rods.

**Bit** Binary digit that can be either on or off.

**Bitmap** An image of any kind, such as a picture, drawing, text character, or photo, composed of a collection of tiny individual dots.

**Blacksmithing (smithing)** *See* Hand forging.

**Blanking** Process of producing a sheet metal part by cutting its entire outside edge in a die with one stroke of the stamping press.

**Blind hole** When a hole does not go through; the depth must be specified.

**Block diagram** Simplified version of the schematic diagram. Simplified symbols exhibit a minimum of detail of the component and generally no connections at individual terminals.

**Blow molding process** Process commonly used to produce hollow products such as bottles, containers, receptacles, and boxes. This process works by blowing hot polymer against the internal surfaces of a hollow mold.

**Blueprint** Contact chemical-printing process of a drawing or other image copied on paper with white lines on a blue background. Also refers to diazo prints, even though they are not true blueprints.

**Body** That portion of a screw thread shaft that is left unthreaded.

**Bolt** Threaded fastener with head on one end; designed to hold two or more parts together with a nut or threaded feature.

**Bolt circle** Holes located in a circular pattern.

**Bore** To enlarge a hole with a single pointed machine tool in a lathe, drill press, or boring mill.

**Boss** Cylindrical projection on the surface of a casting or forging.

**Bottoming tap** Used when threads are needed to the bottom of a blind hole.

**Bottom-up design** Design approach that brings individual components together to form an assembly.

**Bow's notation** System of notation used to label a vector system. A letter is given to the space on each side of the vector, and each vector is then identified by the two letters on either side of it, read in a clockwise direction.

**Brainstorming** Problem-solving method that allows individuals to voice their thoughts and ideas regarding the specific topic, problem, or project at hand.

**Brass** Widely used alloy of copper and zinc.

**Break** Machine used to bend sheet metal in a cold forging process.

**Break corner** Slight relief on a sharp corner.

**Break line** Used to shorten length of a long object or part or to provide a partial view of a feature.

**Brinell test** Performed by placing a known load, using a ball of a specified diameter, in contact with the material surface. Diameter of the resulting impression in the material is measured and the Brinell hardness number (BHN) is then calculated.

**Broken-out section** Portion of a part broken away to clarify an interior feature; no associated cutting-plane line.

**Bronze** Alloy of copper and tin.

**Building section** Used to show relationship between plans and details previously drawn.

**Burr** Rough edge left by a cutting tool or other operation.

**Bus** Aluminum or copper plate or tubing that carries electrical current.

**Bushing** Replaceable lining or sleeve used as a bearing surface.

**Bus layout** Drawing used by construction crews when building current-carrying portion of a substation.



**Butterfly valve** Disc mounted on a stem that is turned one quarter to open and close.

**Buttress threads** Threads designed for applications where high stress occurs in one direction along the thread axis.

**Butt weld** Form of pipe manufacture in which the seam of a pipe is a welded flat-faced joint. Also, a form of welding in which two pieces of material are “buted” against each other and welded.

**Byte** Eight binary digits; roughly, one character.

## C

**Cabinet oblique drawing** Form of oblique drawing in which receding lines are drawn at half scale and usually at a 45-degree angle from horizontal.

**Cable assembly** Assemblies drawn to scale with dimensions and a parts list that is coordinated with the drawing by identification balloons.

**Cable diagram** Drawing associated with multiconductor systems. A multiconductor is a cable or group of insulated wires put together in one sealed assembly.

**Cable harness diagram** See Cable assembly.

**Caburization** Process in which carbon is introduced into a metal by heating to a specified temperature range while in contact with a solid, liquid, or gas material consisting of carbon.

**CAD** See Computer-aided design.

**CAD/CAM** See Computer-aided design/computer-aided manufacturing.

**CADD** See Computer-aided design and drafting.

**CAE** See Computer-aided engineering.

**CAGE code** Five-number code assigned by the Defense Logistic Service Center (DLSC) to all Department of Defense contractors. CAGE stands for Commercial and Government Entity. The CAGE Information report also contains contact information for the vendor.

**Calendering process** Process generally used to create products such as vinyl flooring, gaskets, and other sheet products. This process fabricates sheet or film thermoplastic or thermoset plastics by passing the material through a series of heated rollers.

**CAM** See Computer-aided manufacturing.

**Cam** Machine part used to convert constant rotary motion into timed irregular motion.

**Cam displacement diagram** Similar to a graph representing the cam profile in a flat pattern of one complete 360° revolution of the cam.

**Cam follower** Specialized type of device designed to follow movement.

**Cam motion** Base point from which to begin cam design. There are four basic types of motion: simple harmonic, constant velocity, uniform accelerated, and cycloidal.

**Cam profile** Actual contour of a cam.

**Cap screws** Fine-finished machine screws generally used without a nut.

**Capacitance** Property of an electric circuit to oppose a change in voltage.

**Capacitor** Electronic component that opposes a change in voltage and stores electronic energy; consists of two metal plates with wire connectors separated by an insulator.

**Carat** Refers to the purity of gold, where 1/24 gold is one carat.

**CAQC** See Computer-aided quality control.

**Cartesian coordinate system** Measurement system that uses numerical coordinates to locate points in space according to distances measured in the same unit of length from three intersecting axes.

**Cartographer** Person who draws maps of geographical areas to show natural and construction features, political boundaries, and other features.

**Case hardening** The hardening of the surface layer of the metal.

**Cast iron** Primarily an alloy of iron and 1.7% to 4.5% carbon, with varying amounts of silicon, manganese, phosphorus, and sulfur.

**Casting** Producing an object or part by pouring molten metal into a mold.

**Catalog feature** Existing feature or set of features created and stored in a catalog for use in other models; also known as a *library feature*.

**Cathode ray tube (CRT)** Specialized vacuum tube in which images are produced when an electron beam strikes a phosphorescent surface. In a computer display, the CRT is similar to the picture tube in a television.

**Cavaller oblique drawing** Form of oblique drawing in which receding lines are drawn true size or full scale. Usually drawn at an angle of 45° from horizontal.

**CE** See Concurrent engineering.

**Center** The exact middle of a circle.

**Centerline** Line used to show and locate the center of a circles or an arc and used to represent the center axis of a circular or symmetrical form.

**Center line of bend (CLB)** Line placed half the distance between bend tangents.

**Central forced-air system** Among the most common systems for climate heating and air-conditioning; circulates air from living spaces through or around heating or cooling devices.

**Central processing unit (CPU)** Processor and main memory chips in a computer. Although the CPU is just the processor, it generally is used to refer to the computer.

**Centrifugal casting** Process in which a mold revolves rapidly while molten metal is poured into the cavity.

**Chain dimensioning** When dimensions are established from one point to the next; also known as *point-to-point dimensioning*.

**Chain drives** Drives that transmit power between rotating shafts.

**Chain line** Thick lines of alternatively spaced long and short dashes used to indicate that the portion of the surface next to the chain line receives specified treatment.

**Chain pitch** Distance from the center of one pin to the center of the other pin in one link.

**Chamfer** Angular relief at the last thread of a thread screw that allows the thread to more easily engage with a mating part; slight surface angle used to relieve a sharp corner.

**Change order** See Engineering change order.

**Chart drawings** Drawing used when a particular part or assembly has one or more dimensions that change, depending on the specific application.

**Checker** Person who is responsible for checking drawings for content and accuracy. See also Drafting checker.

- Check valves** Valves that prevent backflow by closing when the fluid stops flowing.
- Chemical machining** Process that uses chemicals to remove material accurately.
- Chilled cast iron** Results from rapidly chilled gray iron castings; an outer surface of white cast iron.
- Chip** Extremely small components as inseparable assemblies of an integrated circuit.
- Chordal addendum (spur gear)** The height from the top of the tooth to the line of the chordal thickness.
- Chordal thickness (spur gear)** The straight line thickness of a gear tooth on the pitch circle.
- Chromium steel** Basis for stainless steel; used where corrosion and wear resistance is required.
- Chuck** Material to be turned in a lathe is held in this holding device.
- CIM** *See* Computer-integrated manufacturing.
- Circle** Closed curve with all points along the curve at equal distances from a point called the *center*. The circle has a total of 360°.
- Circular pattern (CADD)** Copies and organizes a feature around an imaginary circle a designated number of times; places each feature a specified distance from the other.
- Circular pitch (spur gear)** Distance from a point on one tooth to the corresponding point on the adjacent tooth measured on the pitch circle.
- Circular runout** Provides control of single circular elements of a surface (GD&T).
- Circular thickness (spur gear)** Length of an arc between the two sides of a gear tooth on the pitch circle.
- Circularity** Form tolerance characterized by any given cross section taken perpendicular to the axis of a cylinder or cone or through the common center of a sphere (GD&T). The circularity geometric tolerance is formed by two concentric circles.
- Circumference** Distance around a circle on the circle edge.
- Circumscribed polygon** Measured from the polygon flats.
- Cire perdue** *See* Investment casting.
- Classes of threads** Designation of the amount of tolerance and allowance specified for a thread.
- Clearance fit** Condition when, because of the limits of dimensions, there is always a clearance between mating parts.
- Clearance (spur gear)** Radial distance between the top of a tooth and the bottom of the mating tooth space.
- Closed loop** When a robot is constantly monitored by position sensors; the movement of the robot arm must always conform to the desired path and speed.
- Close running fits** Intended chiefly for running fits on accurate machinery with moderate surface speeds and journal pressures where accurate location and minimum play is desired.
- Close sliding fits** Intended for accurate location of parts that must assemble without perceptible play.
- CNC** *See* Computer numerical control.
- CNC program** A sequential list of machining operations in the form of a code that is used to machine a part as needed. *See also* Computer numerical control.
- Coaxial** Means two or more cylindrical shapes that share a common axis.
- Coaxial features** Features that have a common axis such as counterbores, countersinks, and counterdrills.
- Coded section lines** Lines used to represent specific material section line symbols in a sectional view.
- Code of ethics** Formal document that states an organization's values and the rules and principles that employees are expected to follow.
- Coil** (1) In electronics, a conductor wound on a form or in a spiral; contains inductance. (2) One 360° revolution of the wire used to make the spring.
- Coincident** Geometric construction that specifies two points sharing the same position.
- Cold rolled steel (CRS)** Additional cold forming of steel after initial hot rolling; cleans up hot formed steel.
- Cold saws** Saws used for precision cutoff operations, to cut saw kerfs, and to slit metal, among other manufacturing uses.
- Collaborative engineering** Cooperative exchange of resources; for example, information, and ideas among a virtual team focused on an engineering-intensive project and having an overall common creative purpose.
- Collet** Device that holds material to be turned in a lathe.
- Columbium** Metallic element used in nuclear reactors because it has a very high melting point—4380°F (2403°C)—and is resistant to radiation.
- Command** Specific instruction issued to a computer by an operator. The computer performs a function or task in response to a command.
- Compass** Manual drafting instrument used to draw circles and arcs.
- Component** Individual parts and subassemblies used to create an assembly.
- Composite** Two or more materials bonded together by adhesion.
- Composite positional tolerancing** Allowance used when it is desirable to permit the location of a pattern of features to vary within a larger tolerance than the positional tolerance specified for each feature.
- Composite tolerance** Combination of more than one geometric tolerance applied to the same feature.
- Compression length** Maximum recommended design length for a spring when compressed; also called *solid length*.
- Compression molding** Process that uses a specific amount of material that is heated and placed in a closed mold where additional heat and pressure are applied until the material takes the desired shape.
- Compression spring** Spring that releases its energy and returns to its normal form when compressed.
- Compressive** Pushing toward the point of currency, as in forces that are compressed.
- Computer** Device that receives input, stores and manages data, and provides output.
- Computer animation** Animation made by defining or recording a series of still images in various positions of incremental movement that appear as unbroken motion when played back.
- Computer numerical control (CNC)** Control of a process or machine by encoded commands that are commonly prepared by a computer; also known as *numerical control (NC)*.
- Computer-aided design (CAD)** Process that uses computers for designing; also referred to as *computer-aided drafting*.
- Computer-aided design/computer-aided manufacturing (CAD/CAM)** System in which a part is designed on a computer and

transmitted directly to a computer-driven machine tool that manufactures the part.

**Computer-aided design and drafting (CADD)** Process of using a computer with CADD software for design and drafting applications.

**Computer-aided engineering (CAE)** Method of using computers in design, analysis, and manufacturing of a product, process, or project.

**Computer-aided manufacturing (CAM)** Uses computers to assist in creating or modifying manufacturing control data, plans, or operations and to operate machine tools.

**Computer-aided quality control (CAQC)** System of information on the manufacturing process and quality control collected by automatic means while parts are being manufactured. This information is fed back into the system and compared to the design specifications or model tolerances.

**Computer-integrated manufacturing (CIM)** Brings together all the technologies in a management system, coordinating CADD, CAM, CNC, robotics, and material handling from the beginning of the design process through product packaging and shipment. The computer system is used to control and monitor all the elements of the manufacturing system.

**Concentric** Two or more circles sharing the same center.

**Concentricity** Tolerance used to establish a relationship between the axes of two or more cylindrical features of an object; establishes a median point to axis control.

**Concrete** Mixture of Portland cement, sand, gravel (stones, crushed rock), and water.

**Concrete block** A cement block or foundation block. A concrete block is a rectangular concrete form used in construction. Also called a *concrete masonry unit (CMU)*.

**Concrete masonry unit (CMU)** See Concrete block.

**Concrete slab details** Details drawn to provide information of the intersections of the concrete slabs.

**Concrete slab plan** Plan drawn to outline the concrete used to construct a floor.

**Concurrent engineering (CE)** An integrated approach to design, production, and customer service that emphasizes the advantages of simultaneous, or concurrent, product design by employing individuals from various areas of the business in the up-front concept and design phase, with special emphasis on customers and their needs.

**Concurrent forces** Forces that act on a common point.

**Conductor traces (lines)** Lines that connect the pads to complete the circuit design. Design characteristics of conductors.

**Conduit detail drawings** Drawings that coordinate with the layout by providing construction details and the locations of various fittings, junction boxes, and brackets.

**Cone distance (bevel gear)** The slant height of the pitch cone.

**Coned disk spring** Conically shaped spring washer for use as a compression spring.

**Constant force spring** Spring made of strip spring material similar to a spiral torsion spring. The inner end is normally not fastened, so it is free to rotate.

**Constant velocity motion** Used for the feed control of some machine tools when the follower must rise and fall at a uniform rate. Also known as *straight line motion*.

**Constraint** (1) A condition, such as a specific size, shape, or requirement that defines and restricts a design and must be satisfied in order to achieve a successful design. (2) In CADD, geometric characteristics and dimensions that control the size, shape, and position of model geometry. Also called a *parameter*.

**Construction document** Drawing and written specifications prepared and assembled by architects and engineers for communicating the design of a project and administering the construction contract.

**Construction line** Very lightly drawn nonreproducing line used for the layout of a drawing.

**Container** In CADD, any source of drawing content or other information accessible by a disk, folder, file, or URL.

**Continuation sheet title block** Block that includes, at a minimum, the drawing number, scale, sheet size, CAGE code, and sheet number.

**Contour flange** A sheet metal feature that uses an open profile to create linear sheet metal fabrications.

**Contour interval** Distance in elevation between contour lines.

**Contour line** Line that denotes a series of connected points at a particular elevation.

**Contour roll** Sheet metal feature that uses an open profile rolled around an axis to create a curved sheet metal feature.

**Contract documents** These are legal requirements that become part of the construction contract.

**Control charting techniques** Techniques that use the natural variation of a process to determine how much the process can be expected to vary if it is operationally consistent.

**Control limit** See Upper control limit (UCL) and Lower control limit (LCL).

**Controlled radius** Term applied when the limits of the radius tolerance zone must be tangent to the adjacent surfaces.

**Control valve** Valve used when complex processes used in industry demand instantaneous control and adjustment of flow, pressure, and temperature.

**Conventional breaks** Used when a long object of constant shape throughout its length requires shortening.

**Cope** Second or upper half of the pattern forming a sand casting.

**Coplanar forces** Forces that all lie in the same plane.

**Coplanar profile** GD&T tolerance used when it is desirable to treat two or more separate surfaces that lie on the same plane as one surface.

**Coplanar surfaces** Two or more surfaces on a part that are on the same plane.

**Copper** Metallic element that is easily rolled and drawn into wire, has excellent corrosion resistance, is a great electrical conductor, and has better ductility than any metal except for silver and gold.

**Copper pipe** An expensive corrosion-resistant pipe that has good heat-transfer properties but a low melting point.

**Copyright** The legal rights given to an author of an original work such as writing, music, or art.

**Core** A hole or cavity in a casting that helps to reduce the amount of material removal later or that establishes a wall thickness.

**Core print** Place for positioning the core in the mold when casting.

**Corner relief** Material cut away from a corner to relieve stress and help in the forming process.

**Counterbore** To cylindrically enlarge a hole; generally allows the head of a screw or bolt to be recessed below the surface of an object.

**Counterdrill** Machined hole that looks similar to a countersink-counterbore combination.

**Countersink** Used to recess the tapered head of a fastener below the surface of an object.

**Coupling circuitry** Connections between electronic components.

**Course (civil)** Refers to each element or line of a traverse.

**Crank** Link, usually a rod or bar, that makes a complete revolution around a fixed point.

**Creativity** The ability to produce through imaginative skill, to make or bring into existence something new, to form new associations, and to see patterns and relationships between diverse information.

**Crest** The top of external threads and the bottom of internal threads.

**Cross-functional team approach** In engineering design, when everyone is involved in cooperation as a team rather than when one person or group does something and then passes the completed portion on to the next person or group.

**Cross-helical gears** Gears that provide for nonintersecting right angle shafts with low load-carrying capabilities; also called *right-angle helical gears* or *spiral gears*.

**Cross-reference zoning** Used to indicate the location of a section back to the viewing location on a previous page.

**Crown backing (bevel gear)** The distance between the cone apex and the outer tip of the gear teeth.

**CRT** See Cathode ray tube.

**Cursor** (1) Small rectangle, underline, or set of crosshairs that indicates current location on a video display screen. (2) Handheld input device used in conjunction with a digitizer.

**Curve data (civil)** Any measurements or features used to create a road layout. The following terms are used in curve data: curve radius (R), curve length (L), and included angle of the curve ( $\Delta$ ).

**Curved line** Line that can be in the form of an arc with a given center and radius or an irregular curve without a defined radius.

**Curve length** Distance from one endpoint of a curve to the other endpoint along the circumference.

**Cut** Refers to any process, such as shearing, punching, laser jet, water jet, or similar process that is used to remove material.

**Cutting** Process performed when a die penetrates a material to create a hole of a desired shape and depth or to remove material by cutting away.

**Cutting-plane lines** Thick lines used to identify where a sectional view is taken.

**Cycloidal** From the word *cycloid*, a curved line generated by a point on the circumference of a circle as the circle rolls along a straight line.

**Cycloidal motion** The most popular cam profile development for smooth-running cams at high speeds.

**Cylindrical elbows** Devices used to make turns or corners in ductwork.

**Cylindrical roller bearings** Bearings that have a high radial capacity and assist in shaft alignment.

**Cylindricity** Form tolerance not referenced to a datum and identified by a tolerance zone that establishes two perfectly concentric cylinders within which the actual surface must lie.

## D

**Dardelet thread** Thread form primarily used in situations where a self-locking thread is required.

**Data** Defined as information represented in a formal manner suitable for communication, interpretation, or processing.

**Data list (DL)** A tabulation of all engineering drawings, associated lists, specifications, standards, and subdata lists related to the item for which the data list applies.

**Data set (dataset)** A collection of data, usually presented in tabular form.

**Datum** Theoretically exact point, axis, or plane derived from the true geometric counterpart of a specified datum feature. The origin from which the location or geometric characteristics of features of a part are established.

**Datum feature** Actual feature of the part that is used to establish a datum.

**Datum feature simulator** Opposite shape of the datum feature.

**Datum plane** Theoretically exact plane established by the simulated datum of the datum feature.

**Datum precedence** Precedence established by the order of datum identification placement in the feature control frame.

**Datum reference frame (DRF)** Three selected datum features that are perpendicular to each other.

**Datum targets** Designated points, lines, or surface areas that are used to establish the datum reference frame.

**DC biasing** Basic circuitry that makes any electronic device function.

**Declination** Line that goes downward from its origin; assigned negative values.

**Dedendum (spur gear)** Radial distance from the pitch circle to the bottom of the tooth.

**Dedendum angle (bevel gear)** Angle subtended by the dedendum.

**Default** Action automatically taken by computer software unless an operator specifies differently.

**Deflection** Movement from free length to the solid length in a compression spring, and the movement of a spring from free position to maximum open position in an extension spring.

**Deformed reinforcing** Reinforcing bars with raised ridges to hold better in concrete.

**Degrees of freedom** Number of coordinates it takes to exclusively control the position of a part.

**Deliverables** Include engineering or construction drawings or CADD files, prototypes, life cycle plans, installation manuals, and instruction guides, service and maintenance manuals, manufacturing process specifications, product support equipment, materials, spare parts, customer training plans, and a final project report.

**Delta angle ( $\Delta$ )** Included angle of a curve.

**Delta note** Specific note placed with general notes and keyed to the drawing with a delta symbol ( $\Delta$ ). Also known as a *flag note*.

**Depth of thread** Distance between the crest and root of a thread as measured perpendicular to the axis.

**Derived components** Catalog features that can contain a complete model consisting of several features or even multiple parts.

**Descriptive geometry** Drafting method used to study 3-D geometry with 2-D drafting applications, where planes of projections analyze and describe the true geometric characteristics.

**Design drawings** Drawings that contain all the details required to prepare structural drawings.

**Design HP** Takes into account the type of service and the efficiency of a particular machine.

**Design specifications** Include competitive product investigation, customer research, expected life or warranty, and certification requirements. Established during concept phase, give guidelines to the project team and help identify what constitutes a successful design. Examples of these activities include competitor testing, performance goals and life goals, certification requirements, voice of the customer, and design input from the product description or business case. These technical specifications are then communicated in a document called the design specification.

**Destructive test (DT)** Uses application of a specific force on the weld until the weld fails.

**Detachable chain** Lightest, simplest, and least expensive of all chains; capable of transmitting power up to 25 HP at low speeds.

**Detail assembly** Product shown with its component parts assembled in a manufacturer's catalog or on its Web site that shows the details of parts combined on the same sheet with an assembly of the parts.

**Detail drawing** (1) Manufacturing drawing of an individual part that contains all of the views, dimensions, and specifications necessary to manufacture the part. (2) HVAC drawing used to clarify specific features of an HVAC plan. (3) Structural drawing showing in a condensed form the final results of structural designing. Drawings, general notes, schedules, and specifications serve as instructions to the contractor. (4) Drawings of individual parts of an assembly.

**Detail view** Structural view that can be used in situations where it is necessary to show more detail than is displayed in the existing view.

**Detailed representation (threads)** Used in special situations that require a pictorial display of threads such as in a sales catalog or a display drawing because they represent the appearance of the actual thread form.

**Detailer** Term sometimes used to describe a drafter in the structural drafting discipline.

**Diameter** Distance across a circle measured through the center. A diameter dimension is represented on a drawing with the  $\varnothing$  symbol.

**Diametral pitch** Refers to gear tooth size; has become the standard for tooth size specifications; ratio equal to the number of teeth on a gear per inch of pitch diameter.

**Diaphragm valve** Diaphragm of rubber, neoprene, butyl, silicone, or other flexible material used in place of a disc or other type of sealing mechanism.

**Diazo** Printing process that produces blue, black, or brown lines on various media (other resultant colors are also produced with certain special products). The print process is a combination of exposing an original in contact with a sensitized material exposed to an ultraviolet light and then running the exposed material through an ammonia chamber to activate the remaining sensitized image to form the desired

print. This is a fast and economical method of making prints was once commonly used in drafting.

**Die** (1) Machine tool used to make external threads. (2) Any casting, forging, or sheet metal device used to produce a desired shape, form, or finish to a material.

**Die casting** Injection of molten metal into a steel or cast iron die under high pressure.

**Differential relays** Provide a switching connection between a circuit with two different voltage values.

**Diffusers (air-supply registers)** Ducts connected to openings that put warm air (WA) or cold air (CA) in the room.

**Digital product definition datasets** Computer files that completely define a product.

**Digital prototype** Computer-generated model or original design that has not been released for production.

**Digital prototyping** Method of using CADD to help solve engineering design problems and provide digital models for project requirements.

**Digitize** To put into digital form used by a computer.

**Digitizer** An electronically sensitized flat board or tablet that serves as a drawing surface for the input of graphics data. Draw or trace images using the digitizer and select commands and symbols from a menu attached to it. Also known as a *graphics tablet*.

**Digitizing** Method of transferring hard-copy drawing information from a digitizer into a computer.

**Dihedral angle** Angle formed by two intersecting planes.

**Dimension** Numerical value, values, or mathematical expression provided in appropriate units of measure and used to define form, size, orientation, or location of a feature or part.

**Dimension lines** Lines that indicate length of a dimension. Thin lines capped on the ends with arrowheads and broken along the length, providing a space for the dimension numeral. The gap between the dimension line and the dimension numeral varies but is commonly .06 in. (1.5 mm). This standard varies with architectural drafting.

**Dimension origin** Symbol used when the dimension between two features must clearly identify from which feature the dimension originates.

**Dimension style (CADD)** Presets many dimension characteristics to control the appearance of dimension elements.

**Dimensional accuracy points** Set of four equally spaced points located in a rectangular pattern within the drawing border to establish a means of dimensioning horizontally, vertically, or diagonally across a drawing to validate dimensional accuracy.

**Dimensional constraints (CADD)** Measurements that numerically control the size or location of geometry.

**Dimensional lumber** Wood construction members that have been planed and cut to standardized width and depth specified in inches or millimeters.

**Dimensioning and tolerancing block** Used to specify the general dimensioning and tolerancing specifications found on a drawing.

**Dimension text** Text displaying dimension value, normally .12 in. (3 mm) high, centered in the space provided in the dimension line.

**Dimetric drawing** Pictorial drawing in which two axes form equal angles with the plane of projection. These can be greater than  $90^\circ$  but less than  $180^\circ$  and cannot have an angle of  $120^\circ$ . The third axis may have an angle less or greater than the two equal axes.

**Diode** Simplest semiconductor device.

**Dip** Slope of a stratum.

**Direct dimensioning** Dimensioning applied to control the specific size or location of one or more features.

**Direct numerical control (DNC)** The CAD/CAM system is electronically connected to the machine tool. This electronic connection is called *networking*. This direct link requires no additional media such as paper, floppy disks, CDs, or tape to transfer information from engineering to manufacturing.

**Directional relays** Relays that operate only when current flows in one direction.

**Displacement diagram** A graph; the curve on the diagram is a graph of the path of the cam follower. In the case of a drum cam displacement diagram, the diagram is actually the developed cylindrical surface of the cam.

**Displacement (linkage)** Combination of the stroke and piston diameter determines the piston displacement, or the total movement of the cam follower in one 360° rotation of the cam.

**Dividers** Used to transfer dimensions or to divide a distance into a number of equal parts.

**Documentation** Instruction manuals, guides, and tutorials provided with any computer hardware and software system.

**Documents** General term that refers to all drawings and written information related to a project.

**Double bend (sheet metal)** Bend between two parallel faces that are not coplanar.

**Double lead** (1) Thread that engages two pitches when rotated 360°. (2) Worm that advances two pitches with each revolution.

**Double pitch roller chain** Chain designed mostly for situations with long center distances such as conveyors.

**Double-row ball bearings** Bearings that can be used where shaft alignment is important.

**Dovetail** Slot with angled sides that can be machined at any depth and width.

**Dowel pin** Cylindrical fastener used to retain parts in a fixed position or to keep parts aligned.

**Draft** Taper on the surface of a pattern for castings or the die for forgings, designed to facilitate removal of the pattern from the mold or the part from the die. Often 7–10 degrees but depends on the material and the process.

**Drafter** Person who prepares detailed drawings of objects that will be manufactured or built.

**Drafting** Graphic language using lines, symbols, and notes to describe objects to be manufactured or built.

**Drafting checker** Person who takes a completed drawing from a drafter and evaluates it for proper standards, technical details, and accuracy for product design and dimensioning applications.

**Drafting machine** Machine that mounts to the table or board and has scales attached to an adjustable head that rotates for drawing angles. When locked in a zero position, the scales allow drawing horizontal and vertical lines and perpendicular lines at any angle of orientation.

**Drag** First or lower half of the pattern forming a sand casting.

**Drag and drop** Computer term referring to an activity by which operations are performed by moving an icon of an object with a mouse

into another file, window, or icon. Files can be copied or moved by dragging a desired item from one location and dropping it in another location.

**Drawing area cursor** Often displayed as a crosshair but can be shown as a wand or point, depending on the CADD program or applications.

**Drawing content** All of the objects, settings, and other elements that make up a drawing.

**Drawing dimensions** In CADD, dimensions that are placed as alternatives or in addition to model dimensions to fully describe a drawing.

**Drawings** Drawings depend on the specific requirements of the construction project and constitute plan views, elevations, sections, details and also schedules that have a detailed list of components, items, or parts to be furnished in the project.

**Drill** Tool used to machine new holes or enlarge existing holes in material.

**Drilling drawing** Used to provide size and location dimensions for trimming a printed circuit board.

**Drilling machine** Commonly used to machine drill holes; often referred to as a *drill press*.

**Drum cam** Cylinder with a groove on its surface. As the cam rotates, the follower moves through the groove, producing a reciprocating motion parallel to the axis of the camshaft. Also called *cylindrical cam*.

**Drum plotter** Graphics pen plotter that can accommodate continuous feed paper or in which sheet paper or film is attached to a sheet of flexible material mounted to a drum. The pen moves in one direction and the drum in the other.

**Dryseal pipe thread** Form based on the NPT thread; with some modifications and greater accuracy of manufacture, it can make a pressure-tight joint without a sealer.

**Duct** Sheet metal, plastic, or other material pipe designed as the passageway to convey air from the HVAC equipment to the source. Also called *ductwork*.

**Ductility** The ability to be stretched, drawn, or hammered without breaking.

**Dumb solids (CADD)** Created using basic solid modeling methods; contain very little, if any, information about specific parameters, dimensions, constraints, part history, or features. Only fundamental volume information, such as length, width, and height, are stored in dumb solids. Also known as *basic solids*.

**Dusting brush** Brush designed to remove eraser particles from a drawing.

**Dwell** Exists when the follower is constant, not moving either up or down.

**Dynamic load** Type of load that changes in the direction or degree of force during operation.

**Dynamics** Branch of physics that studies the motion of objects and the effects of the forces that cause motion.

**Dynamic seals** Seals such as packings that contact the moving parts of the machinery.

## E

**Easement** Legal right of access over land owned by another for the purpose of access, egress, utilities, or other designated uses.

**Eccentric circles** Circles having different centers.

**ECO** See Engineering change order.

**ECR** See Engineering change request.

**Electrical circuits** Circuits that provide the path for electrical flow from a source through system components and connections and back to the source.

**Electrical conduit** Electric wires that provide power are resting inside pipes.

**Electrical drafting** Drafting that deals with concepts and symbols that relate to high-voltage applications from the production of electricity in power plants through distribution to industry and homes.

**Electrical relays** Magnetic switching devices.

**Electrochemical machining (ECM)** Process in which a direct current is passed through an electrolyte solution between an electrode and the workpiece.

**Electrodischarge machining (EDM)** Process in which material to be machined and an electrode are submerged in a fluid that does not conduct electricity, forming a barrier between the part and the electrode. A high-current, short-duration electrical charge is then used to remove material.

**Electrolysis** Depositing metal on another material through the action of an electric current.

**Electron beam (EB)** Beam generated by a heated tungsten filament and used to cut or machine very accurate features in a part.

**Electronic design automation (EDA) or electronic computer-aided design (ECAD)** Group of software tools for designing electronic systems such as printed circuit boards and integrated circuits.

**Electronic drafting** Drafting oriented toward the design of electronic circuitry for radios, computers, and other low-voltage equipment.

**Electronics** Control of electrons for use in devices that are dependent on low voltage, amperage, and signal paths.

**Element** Any line, group of lines, shape, or group of shapes and text that is so defined by a computer operator.

**Elementary diagrams** Diagrams that provide the detail necessary for engineering analysis and operation or maintenance of substation equipment.

**Elevation symbol** Commonly used symbol on structural drawings to give the elevation of locations from a known zero elevation.

**Elevations** See Exterior elevations.

**Ellipse** Circle seen at an angle. Oval shape that contains two centers of equal radius.

**End milling cutters** Cutters designed to cut on the end and sides of the cutting tool.

**Engineered wood products** A variety of products that have been designed to replace conventional lumber and provide many advantages such as reducing industry dependence on natural lumber.

**Engineering change documents** Documents used to initiate and implement a change to a production drawing; engineering change request (ECR) and engineering change notice (ECN) are examples.

**Engineering change order (ECO) or change order (CO)** Written notification of change that is accompanied by a drawing representing the change.

**Engineering change request (ECR)** Document used to initiate a change in a part or assembly.

**Engineering drawing** Common language of engineering, describing the process of creating drawings for any engineering or architectural application. A graphic language using lines, symbols, and notes to describe objects for manufacture or construction. Also known as *drafting*, *engineering drafting*, *mechanical drawing*, *mechanical drafting*, *technical drawing*, and *technical drafting*.

**Engineering map** A large-scale map showing the information necessary for planning an engineering project.

**Entity** See Element. Also referred to as *object*.

**Equilibrant** Vector that is equal in magnitude to the resultant and has the opposite direction and sense.

**Equilibrium** When a vector system has a resultant of zero, the system is said to be in equilibrium.

**Eradicating fluid** Chemical primarily used with ink on film or to remove lines from sepia (brown) prints.

**Erasing shield** Thin metal or plastic sheets with a number of differently shaped holes and designed to erase small unwanted lines or areas.

**Erection assemblies** Like a general assembly but with dimensions and fabrication specifications commonly included.

**Ergonomics** Science of adapting the work environment to suit the needs of the worker.

**Etched process** Process that results in circuits on a printed circuit board.

**Ethics** Rules and principles that define right and wrong conduct.

**Excavation** Removing earth for construction purposes.

**Execution phase** Phase that begins when a company is ready to invest in the final production of a product.

**Existing product research** Common approach to the design of new and updated products based on existing product research. Also involves redesign of a current product.

**Exploded assembly** Pictorial assembly showing all parts removed from each other and aligned along axis lines.

**Exploded technical illustration** Illustration showing the parts of an assembly placed apart with trail lines showing how the parts fit together; each part is identified with a balloon correlated to a parts list.

**Exporting** Process of transferring electronic data from a database, such as a drawing file, to a different format used by another program.

**Extension lines** Thin lines used to establish the extent of a dimension, starting with a small offset of .06 in. (1.5 mm) from the object and extending .12 in. (3 mm) past the last dimension line.

**Extension springs** Springs that release their energy and return to normal form when extended.

**Exterior elevations** Drawings that show the external appearance of a building. An elevation is drawn at each side of the building to show the relationship of the building to the final grade, location of openings, wall heights, roof slopes, exterior building materials, and other exterior features.

**Extreme form variation** When the form of a feature can vary between the upper and lower limits of a size dimension.

**Extruding** With metal, shaping it by forcing it through a die. Used with plastic to make continuous shapes such as moldings, tubing, bars, angles, hose, weather stripping, films, and any product that has a constant cross-sectional shape. This process creates the desired continuous shape by forcing molten plastic through a metal die.

## F

**Fabrication drawings** See Shop drawings.

**Face angle (bevel angle)** The angle between the top of the teeth and the gear axis.

**Face gear** A combination of bevel gear and spur pinion or of bevel gear and helical pinion.

**Failure mode effect analysis (FMEA)** Technique used to determine possible failures and ways to eliminate them.

**Fair curve** Smooth curve without sharp changes in direction over any portion of its length.

**Fall** When the follower is moving downward.

**Farad** Unit measure of capacitance.

**Fault condition** Short circuit that is a zero resistance path for electrical current flow.

**FDM** See Fused deposition modeling.

**FEA** See Finite element analysis.

**Feature** General term applied to describe a physical portion of a part.

**Feature control frame (GD&T)** Displays characteristic, geometric tolerance, modifiers, and datum reference for an individual feature.

**Feature of size** One cylindrical or spherical surface, a circular element, or a set of two opposed elements or opposed parallel plane surfaces, each of which is associated with a size dimension.

**Feature pattern** In CADD, an arrangement of copies of existing features, generating occurrences of the features.

**Federal Supply Code for Manufacturers (FSCM)** Five-digit numerical code used on all drawings that produce items used by the federal government.

**Feed lines** Lines that run from a component to trunk lines. The lines are identified by code letter, number, or combination of letter and number at the point where each line leaves the component.

**Felt seals** Used where economical cost, lubricant absorption, filtration, low friction, and a polishing action are required. See also Wool seals.

**Ferrous metals** Metals that contain iron such as cast iron and steel.

**Field weld** Weld that is performed on the job site (the field) rather than in a fabrication shop.

**File management** Methods and processes of creating a management system and then storing, retrieving, and maintaining files within guidelines of the computer system.

**File server** Computer in a network with a large storage space that provides a central location for all drawing and document files, so only one working copy of each file exists. All other computers connect to the file server to provide access to the stored files.

**File template** File that stores standard file settings and objects for use in a new file. Each new file uses all of the settings and content included in the file template.

**Filled plastics** Plastics in which a material has been added to improve mechanical properties.

**Fillet** Curve formed at the interior intersection between two or more surfaces.

**Fillet weld** Weld formed in the internal corner of the angle formed by two pieces of metal.

**Find number** See Identification number.

**Finite element analysis (FEA)** Process of applying the finite element method (FEM) to solve mathematical equations related to engineering design problems, such as structural and thermal problems.

**Fire clay** Specific type of clay used in ceramics manufacturing, especially fire brick.

**First-angle projection** Projection type commonly used in Europe and other countries of the world.

**Fit** For screw threads, identifies a range of thread tightness or looseness.

**Fixture** Device for holding work in a machine tool.

**Flag note** Specific note placed with general notes and keyed to the drawing with a delta symbol ( $\Delta$ ) and thus sometimes known as a *delta note*.

**Flange** (1) A thin rim around a part. (2) In piping, the component that creates a bolted connection point in welded pipe. (3) In sheet metal, a feature added to a part to reinforce or stiffen a part edge or to provide a surface for fastening or welding.

**Flange weld** Weld used on light-gage metal joints where the edges to be joined are flanged or flared.

**Flare-bevel groove weld** Weld commonly used to join flat parts to rounded or curved parts.

**Flare-V groove weld** Weld commonly used to join two rounded or curved parts.

**Flaring** Method for joining soft copper pipe and tubing.

**Flask** Entire box used in sand casting; made up of the cope and drag.

**Flat belts** Belts typically used where high-speed applications are more important than power transmission and when long center distances are necessary.

**Flat pattern** Process of converting a hollow object into its true flat geometric form; a 2-D drawing representing the final unfolded part.

**Flat springs** Arched or bent flat-metal shapes designed so when placed in machinery they cause tension on adjacent parts.

**Flat-bed plotter** Pen plotter in which the drawing surface (bed) is oriented horizontally and paper or film is attached to the surface by a vacuum or an electrostatic charge. The pen moves in both the X- and Y-directions.

**Flat-faced follower** Cam follower used in situations in which the cam profile has a steep rise or fall.

**Flatness** Form tolerance in which a tolerance zone establishes the distance between two parallel planes within which the surface must lie.

**Flat wire compression spring** See Wave spring.

**Floating fastener** An application in which two or more parts are assembled with fasteners, such as bolts and nuts, and all parts have clearance holes for the fasteners.

**Floor-plan lighting layout** Provides location and identification of lighting fixtures and circuits.

**Floppy disk** Thin, circular, magnetic storage medium encased in a cover. It comes in 8", 5-1/4", and 3-1/2" sizes.

**Flowchart** Used to show organizational structure, steps, or progression in a process or system.



**Flow diagram** Chart-type drawing that illustrates the organization of a system in a symbolic format.

**Flush contour weld** Weld in which the weld surface is flush with the contour of the material being welded.

**Fly-through** Movement as if a camera is a helicopter flying through an area. *See also* Walk-through.

**FMEA** *See* Failure mode effect analysis.

**Foam molding** Similar process to casting but uses a foam material that expands during the cure to fill the desired mold. The foam molding process can be used to make products of any desired shape or to make sheets of foam products.

**Fold line** Reference line of intersection between two reference planes in an orthographic projection.

**Follower** Reciprocating device whose motion is produced by contact with the cam surface. Also known as a *cam follower*.

**Font** Specific typeface such as Helvetica or Gothic.

**Footing** Lowest member of the foundation system used to spread the loads of the structure across supporting soil.

**Force fit** *See* Interference fit.

**Foreshortened line** Line that appears shorter than its actual length because it is at an angle to the line of sight.

**Foresight** In surveying, the rod reading taken forward to the rod from the transit.

**Forge welding** Metals joined together under extreme pressure. Material welded in this manner is very strong.

**Forging** Process of shaping malleable metals by hammering or pressing between dies that duplicate the desired shape.

**Formaldehyde** Pollution-causing chemical compound used in glues and in construction materials such as plywood, particleboard, carpet, furniture, and components of certain insulations.

**Form tolerances** Tolerances that specify a zone in which the dimensioned feature, the feature's line elements, the feature's derived median plane, or the feature's derived median line must be controlled.

**Foundation** System used to support building loads; usually made up of walls, footings, and piers. In many areas, the term *foundation* is used to refer to the footing.

**Foundation details** Details that are drawn to provide information on the concrete foundation at the perimeter walls and the foundation and pedestals at the center support columns.

**Foundation plan** Plan that shows the supporting system for the walls, floor, and roof.

**Founding** The pouring of molten metal into a hollow or wax-filled mold. Commonly known as *casting*.

**Four-bar linkage** Most commonly used linkage mechanism. Contains four links: a fixed link called the *ground link*, a pivoting link called a *driver*, another pivoted link called a *follower*, and a *coupler*, or link between the driver and follower.

**Free-body diagram** Diagram that isolates and studies a part of the system of forces in an entire structure.

**Free-form fabrication process** Process that uses a computer model that is traced in thin cross sections to control a laser that deposits layers of liquid resin or molten particles of plastic material to form a desired shape. Using the laser to fuse several thin coatings of powder polymer to form the desired shape is also an option for this process. This process is often referred to by the trade name Stereolithography.

**Free running fits** Fits intended for use where accuracy is not essential, where large temperature variations are likely to be encountered, or where both conditions exist.

**Free state variation** Distortion of a part after removal of forces applied during manufacture.

**FSCM** *See* Federal Supply Code for Manufacturers.

**Full auxiliary view** View that shows the true size and shape of an inclined surface and all the other features of the object projected onto the auxiliary plane.

**Full section** Section view in which the cutting plane extends completely through an object.

**Fully constrained** In CADD, a design in which objects have no freedom of movement.

**Function keys** Extra keys on an alphanumeric keyboard that can be utilized in a computer program to represent different commands and functions. The active commands for function keys may change several times in a program.

**Fused deposition modeling (FDM)** Type of rapid prototyping (RP) or rapid manufacturing (RM) technology commonly used within engineering design. The FDM technology is marketed exclusively by Strata-sys Inc. *Also see* Rapid prototyping.

## G

**Gage** Device used to establish or obtain measurements or to inspect a part or parts when verifying matching features.

**Garner spring** Long, close coil extension spring with hook or ring ends so the ends can be joined forming a large loop.

**Gaskets** Made from materials that prevent leakage and access of dust contaminants into the machine cavity.

**Gate** Part of an electronic system that makes the electronic circuit operate; permits an output only when a predetermined set of input conditions are met.

**Gate valve** Valve used exclusively to provide on-off service in a pipe.

**G-code** Computer code used to establish primary machine tool operations such as tool moves.

**Gear** Cylinder or cone with teeth on its contact surface; used to transmit motion and power from one shaft to another.

**Gear and bearing assemblies** Assembly that shows the parts of a complete mechanism as they appear when assembled.

**Gear drives** Drives that transmit power between rotating shafts.

**Gear ratio** The relationship between any two mating gears. This relationship is the same between any of the following: RPMs, number of teeth, and pitch diameters of the gears.

**Gear train** Drive formed when two or more gears are in contact.

**General arrangement (GA) drawing** Scale drawing that provides plan, elevation, and section views and shows equipment, fittings, dimensions, and notes.

**General assembly** Contains features including multiviews, auxiliary views, detail views, and section view selection as needed for a specific product. Each part is identified with a balloon containing a number keyed to a parts list that identifies every part in the assembly.

**GD&T** Geometric dimensioning and tolerancing.

**General arrangement (GA) drawings** *See* Piping drawings.

**General notes** Notes placed separate from specific views and that relate to an entire drawing.

**General tolerance** See Unspecified tolerances.

**Generation** The number of times a copy of an original drawing is reproduced and used to make other copies.

**Geometric characteristic symbols** Symbols used in geometric dimensioning and tolerancing to provide specific controls related to the form of an object, the orientation of features, the outlines of features, the relationship of features to an axis, or the location of features.

**Geometric constraints** In CADD, characteristics applied to restrict the size or location of geometry.

**Geometric constructions** Methods that can be used to draw various geometric shapes or to perform drafting tasks related to the geometry of product representation and design.

**Geometric dimensioning and tolerancing** It is the dimensioning and tolerancing of individual features of a part where the permissible variations relate to characteristics of form, profile, orientation, runout, or the relationship between features.

**Geometric tolerance** General term applied to the category of tolerances used to control form, profile, orientation, location, and runout.

**GHG** See Greenhouse gas.

**Ghost** Line that seems to have been eliminated but still shows on a print.

**Gigabyte (GB)** One billion bytes of data.

**Globe valve** See Regulating valve.

**Glulam beams (GLB)** See Laminated beams.

**Gold** Commonly hardened by adding copper when used for coins and jewelry. Gold coins, for example, are 90% gold and 10% copper.

**Go-no-go gage** Instrument that determines whether a part feature simply passes or fails inspection. No effort is made to determine the exact degree of error.

**Grade of a line** Way to describe the inclination of a line in relation to the horizontal plane. The percent grade is the vertical rise divided by the horizontal run multiplied by 100.

**Grade slope** Percentage given to show amount of slope.

**Graphical kinematic analysis** Process of drawing a particular mechanism in several phases of a full cycle to determine various characteristics of the mechanism.

**Graphical user interface (GUI)** Provides on-screen features that allow interaction with a software program.

**Graphics tablet** See Digitizer.

**Gray iron** Popular casting material for automotive cylinder blocks, machine tools, agricultural implements, and cast iron pipe.

**Great circle** One of an infinite number of circles from any point on Earth that is described by longitude and latitude.

**Green building** Practice of creating structures and using processes that are environmentally responsible and resource efficient throughout a building's life cycle, including site selection and preparation, design, construction, operation, maintenance, renovation, and deconstruction. Also known as *green construction* and *sustainable building*.

**Greenhouse effect** Heat accumulation that occurs when Earth's atmosphere traps solar radiation. Caused by gases such as carbon dioxide, water vapor, and methane that allow incoming sunlight to pass through but trap the heat radiated back from Earth's surface.

**Greenhouse gas (GHG)** Calculation, inventory building, and emissions measurement. GHGs are gases in an atmosphere that absorb and emit radiation, the basic cause of the greenhouse effect.

**Green sand** Specially refined sand that is mixed with specific moisture, clay, and resin; these work as binding agents during the molding and pouring procedures.

**Green technology** Evolving technology that uses methods and materials to develop techniques that are friendly or friendlier to the environment than past methods and material.

**Grid** In electronics, a network of equally spaced parallel lines running vertically and horizontally on a glass or polyester film sheet.

**Grid lines** Pattern of thin, equally spaced perpendicular lines drawn at an exact scale across the face of a drawing to confirm dimensional accuracy.

**Grinding** Process generally used when a smooth, accurate surface finish is required. Extremely smooth surface finishes can be achieved by honing or lapping.

**Grinding machine** Uses a rotating abrasive wheel rather than a cutting tool to remove material.

**Groove welds** Welds commonly used to make edge-to-edge joints; used in corner joints, T-joints, and joints between curved and flat pieces.

**Ground grid** Substation grounding system.

**Ground plane** Continuous conductive area used as a common reference point for circuit returns, signal potentials, shielding, and heat sinks.

**GUI** See Graphical user interface.

**Gunter's chain** A 66-foot-long chain invented by Edmund Gunter and made of 100 links; used in surveying.

## H

**Half section** Section used typically for symmetrical objects; the cutting-plane line actually cuts through one quarter of the part. The sectional view shows half of the interior and half of the exterior at the same time.

**Hand forging** Ancient method of forming metals into desired shapes. Method of heating metal to a red color and then beating it into shape is called *smithing* or, more commonly, *blacksmithing*.

**Haptic interface** A device that relays the sense of touch and other physical sensations.

**Hard copy** Physical drawing or text created on paper or some other media by a printer or plotter.

**Hard disk drive** Internal and primary storage device found in most computers. A hard disk drive is a sealed unit and typically stores software and user-defined files.

**Hard metric conversion** Conversion unit calculated as closely as possible to or exactly the same as the inch equivalent.

**Hardware** Physical components of a computer system, such as the computer, monitor, keyboard, mouse, and printer.

**Headers** Horizontal structural members provided over an opening to support an overhead load.

**Heat pump** Forced-air central heating and cooling system that operates using a compressor and a circulating liquid gas refrigerant; works best in moderate climates.

**Heat-treating** Process of heating and cooling steel using specific controlled conditions and techniques. When steel is initially formed and allowed to cool naturally, it is fairly soft.

**Heating, ventilating, and air-conditioning (HVAC)** System made up of mechanical equipment such as a furnace, heat exchanger, evaporator coil, and ductwork.

**Heavy bearings** Bearings often designed for special service where extra heavy shock loads are required. Also designed to accommodate radial loads, thrust loads, or a combination of loading requirements.

**Heavy drive fits** Fits suitable for heavy steel parts or for shrink fits in medium sections.

**Height of instrument (HI)** In surveying, calculation of the level, which is one factor needed to determine elevation.

**Helical gears** Gears with teeth cut at an angle, allowing more than one tooth to be in contact.

**Helical torsion springs** Designed to provide resistance or to exert a turning force in a plane at 90° to the axis of the coil.

**Helix direction** Direction of a twist used to create a spring; can be specified as right hand or left hand.

**Hem** Extra material on a pattern used for strength and connection at the seams.

**Henry** Unit measurement of inductance.

**Herringbone gear** Double helical gear without space between the two opposing sets of teeth.

**HI** See Height of instrument.

**Hidden line** Line that represents an invisible edge on an object. Hidden lines are thin lines drawn .01 in. (0.3 mm) thick.

**High-carbon steel** Steel with 0.6% to 1.50% carbon; can be hardened by heat-treating but is difficult to forge, machine, or weld.

**High-speed steel** Steel with alloy and hardness characteristics that are improved for cutting tools requiring deep cutting at high speed.

**Highway diagram** Simplified or condensed representation of a point-to-point, interconnecting wiring diagram for an electrical circuit. See also Wireless diagram.

**Highways** See trunk lines.

**Hole table** Common form of tabular dimensioning that specifies the size and location of holes using a table.

**Hone** Method of finishing a hole or other surface to a desired close tolerance and fine surface finish using an abrasive.

**Honing** Fine abrasive process often used to establish a smooth finish inside cylinders.

**Hot-water system** System in which water is heated as it circulates around the combustion chamber of a fuel-fired boiler and then circulated through pipes to radiators or convectors in rooms.

**Hot-rolled steel (HRS)** Steel that is formed into shape by pressure between rollers or by forging when in a red-hot state.

**Hub** The lugs or shoulder projecting from one or both faces of some gears.

**HVAC** See Heating, ventilating, and air-conditioning.

**Hybrid CADD modeling** Software programs that incorporate the functionality of wireframe, surface, basic, and parametric solid modeling. Hybrid modeling systems are often described as separate CADD applications.

**Hydroforming** This is a process by which high-pressure hydraulic fluid is applied to ductile metals to form a specified shape.

**Hydronic radiant floor heating** System of plastic or metal tubes and pipes laid within a floor that carries hot water into specific rooms or zones, dispersing the heat through the floor surface.

**Hypertext** Computer-based text-retrieval system that allows access to specific locations in Web pages or other electronic documents by clicking on links within the pages or documents.

**Hypoid gears** Gears that have the same design as bevel gears except the gear shaft axes are offset and do not intersect.

**IC** See Integrated circuit.

**Identification number** Number used to key parts from an assembly drawing to a parts list. Also called a *find number* or an *item number*.

**Idler** Device often used to help maintain constant tension on a belt.

**I-joint** Joint generally made of softwood veneers such as fir or pine that are bonded together or solid wood to make the top and bottom flanges.

**IK** See Inverse kinematics.

**IML** See Inside mold line.

**Inclination** Line that goes upward from its origin; assigned positive values.

**Included angle** (1) For screw threads, angle between the flanks (sides) of the thread. (2) Angle formed between the center and end-points of an arc.

**Inductance** Property in an electronic circuit that opposes a change in current flow or where energy is stored in a magnetic field as in a transformer.

**Inductor** See coil.

**Industrial design (ID) team** Flexible team of highly skilled and creative people who have extensive product knowledge and experience.

**Infrastructure** Structures, facilities, and services required for an economy to function, such as buildings, roads and bridges, water-supply and sewer systems, and power-supply and telecommunication systems.

**In-house** Refers to any operations conducted in a company's own facility instead of being outsourced.

**Injection molding** Process of injecting molten plastic material into a mold that is in the form of a desired part or product.

**Inkjet plotter** Plotting device that sprays tiny droplets of ink from a cartridge onto print paper to form dot-matrix images.

**Innovation** Process of transforming a creative idea into a tangible product, process, or service.

**Inorganic materials** Includes carbon, ceramics, and composites.

**Input** Entering information into a computer that the computer acts on in some way. Can come from devices such as a keyboard, mouse, or similar input device or from a digitizer.

**Inscribed polygon** Measured from the polygon corners.

**Inside mold line (IML)** Line representing intersection of the projected inside surfaces of a formed feature.

**Integrated circuit (IC)** When all of the components of a schematic are made up of one piece of semiconductor material.

**Integrated product development (IPD)** Process by which a product is designed and developed to satisfy all of the conditions it will encounter in its product life.

**Intellectual property** As taken from the World Intellectual Property Organization Web site (www.wipo.int), is divided into two categories: industrial property and copyright. Industrial property includes inventions (patents), trademarks, and industrial designs. Copyright includes literary and artistic works such as novels, poems, plays, films, and musical works and artistic works such as drawings, paintings, photographs, sculptures, and architectural designs.

**Intelligence** Parametric concept; occurs as a result of a software program's ability to store and manage model information. This information includes knowledge of every model characteristic such as calculations, sketches, features, dimensions, geometric parameters, when each piece of the model was created, and all other model history and properties.

**Interchangeability** Parts manufactured identically within given tolerances. Interchangeable parts are produced to specifications that ensure they are so nearly identical that they will fit into any product for which they are designed.

**Interface** Items that allow a user to input data to and receive output from a computer system.

**Interference fit** Condition that exists when, because of the limits of the dimensions, mating parts must be pressed together. Also known as *force fit* or *shrink fit*.

**Internet** Worldwide network of communication between computers.

**Interpolate** To make an approximation between existing known values.

**Intersecting lines** When lines are intersecting, the point of intersection is a point that lies on both lines.

**Intersecting shafting gears** Gears that allow for a change in direction of motion from the gear to the pinion.

**Intranet** Communication links between computers within a company or organization.

**Invention disclosure** Process that establishes an idea with a written dated document securing the design as yours.

**Inverse kinematics (IK)** Method used to control how solid objects move in an assembly.

**Invert elevation (IE)** The lowest elevation of the inside of a sewer pipe at a particular station.

**Inverted tooth silent chain** Chain used where high speed and smooth, quiet operation are required in rigorous applications.

**Inverter** Appliance used to convert independent DC power into standard household AC current.

**Investment casting** Also called *cire perdue* or *lost-wax* casting. A wax pattern is coated with a ceramic paste. The shell is allowed to dry and is then baked in an oven to allow the wax to melt and flow out. The empty ceramic mold has a cavity that is the same shape as the precision wax pattern. This cavity is then filled with molten metal.

**Involute curve** Spiral curve generated by a point on a chord as it unwinds from the circle.

**Involute spline** Spline similar to the curved teeth found on spur gears.

**IPD** See Integrated product development.

**Irregular curves** In manual drafting, curves that have no constant radii. Also known as *French curves*.

**Isogonic chart** Chart that shows isogonic lines.

**Isogonic lines** Lines that show how many degrees to the east or west the magnetic north or south pole is from the true north or south pole.

**Isometric drawing** Form of pictorial drawing in which all three drawing axes (X, Y, and Z) form equal angles (120°) with the plane of projection.

**Isometric lines** Three principal axes of an isometric drawing and any line on or parallel to them. These lines can all be measured.

**Isometric sketch** Sketch that provides a 3-D pictorial representation of an object.

**Item** Term used to any material, part, unit, or product.

**Item number** See Identification number and Find number.

## J

**J groove weld** Weld used when one piece is a square cut and the other piece is in a J-shaped groove.

**Jig** Device used to guide a machine tool in the machining of a part or feature.

**JIT** See Just-in-time.

**Joint** Connection point between two links.

**Joists** Horizontal structural members used in repetitive patterns to support floor and ceiling loads.

**Joystick** Graphics input device composed of a lever mounted in a small box that allows the user to control the movement of the cursor on a video display screen.

**Justify** To align the margins or edges of text along a straight line. For example, left-justified text aligns along an imaginary left border.

**Just-in-time (JIT)** Inventory approach that seeks to improve return on investment by reducing raw material and production inventory and related costs.

## K

**Kaizen** A continuous improvement activity.

**Kaizen event** An event that brings all owners and members of a process together to conduct a formal review of the process, seeks feedback from the group, gains support from team members, and works toward process improvements that can help the organization achieve better results by improving existing processes within a company.

**KBE** See Knowledge-based engineering.

**Kerf** Groove created by the cut of a saw.

**Key** Machine part used as a positive connection for transmitting torque between a shaft and a hub, pulley, or wheel. The key is placed in position in a keyseat, which is a groove or channel cut in a shaft. The shaft and key are then inserted into a hub, wheel, or pulley, where the key mates with a groove called a *keyway*.

**Keyboard** Input device that allows a user to give written instructions to a computer.

**Keyseat** Groove or channel cut in a shaft.

**Keyway** A groove in a hub, wheel, or pulley where a shaft and key are inserted and mate.

**K-factor** In sheet metal, a ratio of material thickness to the location of the neutral line after bending forces are applied.

**Killed steel** Steel that is degassed and deoxidized before solidification; used for forging, heat-treating, and difficult stampings.

**Kinematics** Study of motion without regard to the forces causing the motion.

**Kinetics** Element of physics that deals with the effects of forces that cause motion in mechanisms such as linkages, cams, and gears.

**Knife-edged follower** Follower used for only low-speed and low-force applications.

**Knowledge-based engineering (KBE)** Use of computer models to simulate the best-known engineering processes.

**Knurling** Cold forming process used to uniformly roughen a cylindrical or flat surface with a diamond or straight pattern.

## L

**Labyrinth** Seal made of a series of spaced strips that are connected to the seal seat, making it difficult for the lubrication to pass. Name *labyrinth* means maze.

**Lag screw** Screw designed to attach metal to wood or wood to wood.

**Laminated beams** Beams manufactured from smaller, equally sized members glued together to form a larger beam. Also known as *lam beams* and *glulam beams*.

**Laminated veneer lumber (LVL)** Engineered structural member manufactured by bonding wood veneers with an exterior adhesive.

**LAN** See Local area network.

**Lancing** Stamping press operation that forms a single-line cut part-way across a sheet without removing material.

**Lapping** Process of creating a very smooth surface finish using a soft metal impregnated with fine abrasives or fine abrasives mixed in a coolant that floods over the part during the lapping process.

**Lap weld** Form of pipe manufacture in which the seam of the pipe is an angular “lap.”

**Large-scale integration (LSI)** The inclusion of more circuits on a single small IC chip.

**Laser** Device that amplifies focused light waves and concentrates them in a narrow, very intense beam. Term is an acronym for light amplification by stimulated emission of radiation.

**Laser machining** When materials are cut or machined by laser with instant temperatures as high as 75,000°F (41,649°C).

**Lathe** Machinery that cuts material by turning cylindrically shaped objects. The material to be turned is held between two rigid supports called *centers* or in a holding device called a *chuck* or a *collet*.

**Latitude** Parallel lines around Earth that do not intersect. The equator is the longest line of latitude.

**Lay** Describes basic direction or configuration of the predominant surface pattern in a surface finish.

**Layer** Element of a CADD drawing that allows a user to separate objects into logical groups for formatting and display purposes.

**Layering process** In plastic composites, combines alternating layers of polymer resin with reinforcing material such as glass. The number of layers determines the desired thickness.

**Layout** In CADD, can show various views of the model, a title block, border, and other annotations such as general notes. In addition, the layout includes page setup information such as paper size and margins and plotter configuration data.

**Layouts** Created in CADD using the Layout tab at the bottom of the drawing area in an environment called *paper space*.

**LCL** See Lower control limit.

**Lead** For a screw thread, the distance that the thread advances axially in one revolution of the worm or thread.

**Leader line** Thin line used to connect a specific note to a feature on a drawing. The leader line can be at any angle between 15°–75°, with 45° preferred. There is a short, horizontal shoulder between .12 and .24 in. (3–6 mm) centered where the line meets the note.

**Lead time** Time interval between the initiation and completion of a production process.

**Lean manufacturing** Production practice that eliminates waste in all departments and in all phases from design through manufacturing and to marketing and distribution.

**Least material condition (LMC)** Lower limit for an external feature and the upper limit for an internal feature.

**Leadership in Energy and Environmental Design (LEED)** An internationally recognized green building certification system, providing third-party verification that a building or community was designed and built using strategies aimed at improving performance in areas such as energy savings, water efficiency, CO<sub>2</sub> emissions reduction, improved indoor environmental quality, and stewardship of resources and sensitivity to their impacts.

**Left-hand thread** Thread that engages with a mating thread by rotating counterclockwise or with a turn to the left when viewed toward the mating thread.

**Leveling** Process of determining elevation using backsight and foresight.

**Lever** Link that moves back and forth through an angle; also known as a *rocker*.

**Life cycle engineering** Engineering that includes evaluation of the entire life of a product at the beginning of the design process.

**Lift check valve** Valve that operates by gravity and is available in horizontal and vertical models.

**Light bearings** Bearings generally designed to accommodate a wide range of applications involving light to medium loads combined with relatively high speeds.

**Light drive fits** Fits that require light assembly pressures and that produce more or less permanent assemblies.

**Light-duty chains** Chains designed for application in low-power situations such as equipment control mechanisms for computers and printers or appliance controls.

**Lighting fixture schedule** List of the light fixtures used in a building.

**Light pen** Video display screen input device. A light-sensitive stylus connected to the terminal by a wire enables a user to draw or select menu options directly on-screen.

**Limit dimensioning** Lists extreme values of a tolerance.

**Limits** Largest and smallest possible boundaries of a dimension to which a feature can be made in relation to the tolerance of the dimension.

**Limits of a size** Dimension that determines the allowed variation in the size of a feature.

**Linear bearings** Bearings designed for thrust loads.

**Line balloon** Symbol in which pipe specification numbers are placed.

**Line contrast** Variation in thickness of lines on a drawing.

**Line of sight** Imaginary straight line from the eye of an observer to a point on the object being observed. All lines of sight for a particular view are assumed to be parallel and are perpendicular to the projection plane involved.

**Links** Defined as any rigid element of a mechanism. Also known as *linkages*.

**LMC** See Least material condition.

**Loading extension** Extended distance to which an extension spring is designed to operate.

**Lobed ring seal** Seal with rounded lobes that provide additional sealing forces over the standard O-ring seal.

**Local area network (LAN)** Network system that connects computers and peripherals within an office or company.

**Local notes** Notes connected to specific features in the views of a drawing. Also commonly called *specific notes* because they are specific to a feature.

**Locational clearance fits** Fits intended for parts that are normally stationary but that can be freely assembled or disassembled.

**Locational fits** Fits that provide rigid or accurate location, as with interference fits, or provide some freedom of location, as with clearance fits.

**Locational interference fits** Fits used where accuracy of location is of prime importance and for parts requiring rigidity and alignment with no special requirements for bore pressure.

**Locational transition fits** Compromise between clearance and interference fits.

**Location dimensions** Dimensions that provide the relationships of an object's features.

**Location tolerances** Tolerances used to locate features from datums or to establish coaxiality or symmetry, including position, concentricity, and symmetry.

**Locator** Fully assembled view of a product, usually shown in the upper left of the page, with an exploded subassembly.

**Logic circuit** Computer-oriented circuit in which the schematic becomes a cross between a flow diagram and a schematic diagram.

**Logic diagram** Type of schematic that is used to show the logical sequence in an electronic system.

**Longitude** Meridians of Earth that run from the north pole to the south pole. Lines of longitude are basically the same length.

**Loose running fits** Fits used where wide commercial tolerances may be necessary, together with an allowance, on an external member.

**Lost-wax casting** See Investment casting.

**Lower control limit (LCL)** The lowest expected variation of the sample averages in the SPC system.

**LSI** See Large-scale integration.

**Lug** Feature projecting out from the body of a part, usually rectangular in cross section.

**LVL** See Laminated veneer lumber.

## M

**Machine forging** Mechanical forging, including upset, swaging, bending, punching, cutting, and welding.

**Machine screw** Thread fastener used for general assembly of machine parts.

**Machine tools** Power-driven tools, such as lathes, drills, and mills.

**Machining** General term used to define the process of removing excess or unwanted material with machine tools for rough or finish turning, boring, drilling, milling, or other processes.

**Machinist** Person who specializes in machining.

**Magnetic declination** Degree difference between magnetic azimuth and true azimuth.

**Major diameter** Distance on an external thread from crest to crest through the axis. For an internal thread, the major diameter is measured from root to root across the axis.

**Malleable** Ability to be hammered or pressed into shape without breaking.

**Management science** See Operations management.

**Manual drafting** Traditional drafting practice using pencil or ink on a medium such as paper or polyester film with the support of drafting instruments and equipment.

**Manufacturing cell** Group of different machines doing work on products that have similar shapes and processing requirements.

**Markups** Drawing revisions.

**Master pattern** One-to-one scale circuit pattern used to produce a printed circuit board.

**Material boundary symbols** Symbols that establish the relationship between the size of the feature within its given dimensional tolerance and the geometric tolerance.

**Material condition symbols** Symbols that establish the relationship between the size of the feature within its given dimensional tolerance and the geometric tolerance.

**Materials science** Study of the fundamental properties and characteristics of materials and material applications.

**Mates** Used in the CADD assembly environment; link individual components together to create an assembly.

**Matte** Nonglossy, slightly textured surface on drafting media.

**Maximum material condition (MMC)** Given the limits of a dimension, the situation in which a feature contains the most material possible. The largest limit for an external feature and the smallest limit for an internal feature.

**Maxwell diagram** Combination vector diagram used to analyze the forces acting in a truss.

**M-code** Computer code used to establish miscellaneous machine tool operations such as tool changes and coolant settings.

**Mechanical drafting** Form of drafting used by the manufacturing industry (its name is derived from mechanisms). Construction industry also uses mechanical drafting, but the term refers to drafting heating, ventilating, and air-conditioning (HVAC) systems, which is the mechanical portion of an architectural project. See also Engineering drawing.

**Mechanical engineer** (1) In HVAC, consulting engineer. (2) In manufacturing, an engineer who designs manufactured products.

**Mechanical joint** Pipe connection that modifies of the “bell and spigot” in which flanges and bolts are used with gaskets, packing rings, or grooved pipe ends to provide a seal.

**Mechanical pencil** Pencil that requires a manually inserted piece of writing lead (graphite); also referred to as *lead holder*.

**Mechanical spring** Elastic body whose mechanical function is to store energy when deflected by a force and to return the equivalent amount of energy on being released.

**Mechanical systems** Residential and commercial structures with heating, ventilating, and air-conditioning (HVAC) systems.

**Mechanics** Study of mechanisms as part of physical sciences.

**Mechanism** Combination of two or more machine members that work together to perform a specific motion.

**Media** Material such as paper and polyester film on which drawings are created.

**Medium bearings** Bearings of heavier construction than light bearings that provide a greater radial and thrust capacity. They are also able to withstand greater shock than light bearings.

**Medium carbon steel** Steel that is harder than mild steel and yet remains easy to forge and machine; contains 0.3% to 0.6% carbon.

**Medium drive fits** Fits suitable for ordinary steel parts or for shrink fits on light sections.

**Medium running fits** Fits intended for high running speeds, heavy journal pressures, or both.

**Melt through** Term that refers to the weld melting through the bottom of the weld or the opposite side of where the weld is being applied.

**Metal grain** Predominant direction of crystals in a metal.

**Metal injection molding (MIM)** Powder metallurgy process that can produce very complex parts. Process injects a mixture of powder metal and a binder into a mold under pressure. The molded product is then sintered to create properties in the metal particles that are close to a casting.

**Metallurgist** Person who performs metallurgy applications.

**Metallurgy** Part of materials science that studies the physical and chemical behavior of metals and alloys.

**Metes and bounds systems** System of describing portions of land by using lengths and boundaries.

**Metrics** Term frequently used in engineering to stand for product requirements such as weight, dimensions, operation performance criteria, comfort, and other physical factors included in a design.

**Metric thread** International Organization for Standardization thread specifications that are similar to the Unified thread form.

**Micro** Term meaning millionth; represented by symbol  $\mu$ .

**Microfilm** Film on which printed materials are photographed at greatly reduced size for ease of storage.

**Mild steel (MS)** Steel low in carbon content (less than 0.3%) and commonly used for forged and machined parts; it cannot be hardened.

**Milling machine** One of the most versatile machine tools using a rotary cutting tool to remove material from the work. The two general types of milling machines are horizontal and vertical mills.

**MIM** See Metal injection molding.

**Minimum required annular ring** Smallest part of the circular strip of conductive material surrounding a mounting hole that meets design requirements.

**Minor diameter** Dimension from root to root through the axis on an external thread and measured across the crests through the center for an internal thread.

**Mirrored feature** Mirrors an existing feature across a plane in a CADD drawing.

**Miter gears** Same as bevel gears, except both the gear and pinion are the same size and are used when shafts must intersect at 90° without speed reduction.

**MMC** See Maximum material condition.

**Mobile computers** Small computer that are light enough to use on a lap. Commonly called *laptop* or *notebook computers*.

**Model** Various objects such as lines, circles, and text that make up the bulk of a CADD drawing.

**Model dimensions** Model CADD parameters, such as dimensional constraints and feature specifications, that are available to use as dimensions in a drawing.

**Modeling failure** The result of dimensions or geometric controls that are impossible to apply to the CADD model. Overconstrained and modeling failure situations must be resolved before a featured and fully parametric model can be created. A sketch or model also cannot contain enough parameters.

**Model space** The environment in AutoCAD in which drawings and designs are created.

**Modified constant velocity motion** Type of motion designed to help reduce the abrupt change at the beginning and end of the motion period. Can be adjusted to accomplish specific results by altering the degree of modification.

**Mold** Form made to pour or inject material to produce a desired shape.

**Molded lip packings** Packings that provide sealing as a result of the pressure generated by a machine fluid.

**Molded ring seals** Seals placed in a groove that provide a positive seal between the shaft and bearing or bushing. Types of molded ring seals include labyrinth, O-ring, and lobed ring.

**Monodetail drawing** Drawing of a single part on one sheet.

**Mortar** Combination of cement, sand, and water used to bond masonry units together.

**Mouse** Pointing and input device that allows a user to control the movement of the screen cursor and make selections on-screen.

**Movable datum target** Symbol used to indicate that the datum target is not fixed at its basic location and is free to translate.

**MS** See Mild steel.

**Multiaxis milling machining** CNC machine tools that move in four or more directions to allow the manufacturing of complex parts with curved features.

**Multiconductor** Cable or group of insulated wires put together in one sealed assembly.

**Multidetail drawing** Drawing of several parts on one sheet.

**Multifunctional** Being able to perform a variety of operations based on a program and its tools.

**Multilayer boards** Circuit boards printed on both sides; most of the components are on one side, and the circuitry is on the other.

**Multilayer sandwich boards** Many thin boards laminated together, with the components on one or both sides of the external layers.

**Multiview drawing** Drawing that represents the shape of an object using two or more views.

**Multiview projection** Views of an object as projected on two or more picture planes in orthographic projection.

## N

**Nails** Fasteners used in the fabrication of wood-to-wood members; sized by the term *penny* and denoted by lowercase letter d.

**Natural rubber** A material that starts as the sap from some trees.

**NC** See Numerical control.

**Neck** Groove around a cylindrical part.

**Needle roller bearings** Bearings with small rollers that are designed for the highest load-carrying capacity of all rolling element bearings with shaft sizes less than 10 in.

**Needle valve** Valve with fine threads that allow it to be adjusted exactly to achieve accurate throttling.

**Nesting blanks** Arrangement of sheet metal patterns on sheet stock to minimize scrap during the stamping process.

**Network** Communication or connection system that allows each computer to link to other computers, printers and plotters, data-storage devices, and other equipment.

**Nodular cast iron** Cast iron created with special processing procedures. Addition of magnesium- or cerium-bearing alloys results in cast iron with spherically shaped graphite rather than flakes as in gray cast iron.

**Nominal pipe size (NPS)** Value used for sizing pipe; inside pipe diameter.

**Nominal size** Size designation for a commercial product.

**Nomograph** Graphic representation of the relationship between two or more variables of a mathematical equation.

**Nonassociative dimension** CADD dimension linked to point locations, not objects; does not update when an object changes.

**Nondestructive (NDS) testing** Tests for potential defects in welds; they do not destroy or damage the weld or the part.

**Nondirectional relays** Relays that operate when current flows in either direction.

**Nonferrous metals** Metals that do not have iron content—for example, copper and aluminum.

**Nonintersecting shaft** Gears with shafts that are at right angles but do not intersect.

**Nonisometric lines** (1) Lines that appear either longer or shorter than they actually are. (2) Any lines not on or parallel to the three isometric axes.

**Nonprecision chains** Chains that do not have as high a degree of precision between the sprocket and chain links.

**Nonuniform rational B spline (NURBS)** Mathematics used by most surface modeling CADD systems to produce accurate curves and surfaces.

**Normalizing** Process of heating steel to a specific temperature and then allowing the material to cool slowly by air, bringing the steel to a normal state.

**Normal plane** Plane surface that is parallel to any primary projection plane.

**Notes** Type of dimension that generally identify the size of a feature or features with written specifications that are more detailed than numerical values.

**NPS** See Nominal pipe size.

**Numerical control (NC)** System of controlling a machine tool by means of numeric codes that direct the commands for the machine movements; computer numerical control (CNC) is a computer command control of the machine movement.

**NURBS** See Nonuniform rational B spline.

**Nut** Element that is tightened on a bolt or bolt head and that can be tightened into a threaded feature.

## O

**Oblique drawing** Form of pictorial drawing in which the plane of projection is parallel to the front surface of the object and the receding angle is normally 45°.

**Oblique line** Straight line that is not parallel to any of the six principal planes.

**Oblique plane** Plane inclined to all of the principal projection planes.

**Offset section** When a cutting plane is offset through staggered interior features of an object to show those features in section as if they were in the same plane.

**Offset sidebar** Least expensive precision chain designed to carry heavier loads.

**Ohm** Unit measurement of resistance.

**One-line diagram** Simple way for electrical engineers and drafters to communicate the design of an electrical power substation.

**Open-loop robotic system** System that does not constantly monitor the position of a tool while a robot arm is moving.

**Operational amplifier (OPAMP)** High-gain amplifier created from an integrated circuit.

**Operations management** Use of mathematics and optimization techniques to prioritize a project portfolio. Management science or operations management use a mathematical process in which a business or engineering solution is simulated to determine optimum results. Also known as *management science*.

**Optical disk drive** Thin disk coated with plastic that stores data as tiny pits etched in the surface. A laser reads digital impulses and transforms the data into audio or digital information.

**O-ring seal** Most commonly used seal because of its low cost, ease of application, and flexibility.

**Orthographic projection** Any projection of the features of an object onto an imaginary plane called a *plane of projection*.

**Output** Information that a computer sends to a receiving device such as a monitor, plotter, or printer.

**Outside diameter (spur gear)** Overall diameter of a gear; equal to the pitch diameter plus two times the addendum.

**Outside mold line (OML)** Short thin-line segment representing the intersection of the projected outside surfaces of a formed feature.



**Outsourcing** Sending elements of a project to subcontractors for completion.

**Overconstrained** In CADD, a design that contains too many constraints; not possible within a parametric model.

**Overlay drafting** Creating several drawings containing different information on the same outline.

## P

**P&ID** See Process and instrumentation diagram.

**Pads** Circuit-termination locations where electronic devices are attached to printed circuit boards. Also called *lands*.

**Panel elevations** Used when exterior elevations do not clearly show information about items located on or in walls.

**Panel plan** Plan used in tilt-up construction to show the location of panels.

**Paper space** Environment in AutoCAD in which a final drawing is plotted to scale. Also known as *paper layout*.

**Parallel bar** Device that slides up and down a drafting board to allow horizontal lines to be drawn.

**Parallelism** Condition of a surface or center plane equidistant from a datum plane or axis.

**Parallel lines** Lines equidistant throughout their length; if they were to extend indefinitely, they would never cross.

**Parallelogram** Quadrilateral form with parallel sides.

**Parameter-driven assembly** Element that allows changes made to individual parts to be reproduced automatically as changes are made in a CADD assembly and assembly drawing.

**Parameters** Geometric characteristics and dimensions that control the size, shape, and position of model geometry in CADD. Also called *constraints*.

**Parametric** Method of using parameters and constraints to drive object size and location to produce designs with features that adapt to changes made to other features.

**Parametric design** Design that enables a user to enter certain values or information that software uses to create or change drawings based on this input.

**Parametric solid modeling** Developing solid models in CADD that contain parameters (controls), limits, and checks that allow the user to easily and effectively make changes and updates. This way, when the size, shape, and location of model geometry are described with specific parameters, they can be easily modified to explore alternative design options.

**Parcel of land** Area of land often referred to as a *plot*, *lot*, or *site*. This parcel typically has its boundary lines established by a legal description that contains specific information about location, property line lengths, and bearings using one or more methods used to describe land.

**Part** Item, product, or element of an assembly.

**Partial auxiliary view** Auxiliary view that shows only the true size and shape of an inclined surface.

**Partial view** View that can be used when symmetrical objects are drawn in limited space or when there is a desire to simplify complex views.

**Parting line** (1) Separation between a mold or die components. (2) A line on the drawing that represents the mating surfaces between the mold or die components.

**Parting plane** Plane that represents the mating surfaces of a die or mold.

**Parts list (PL)** Identifies every part in an assembly; a tabulation of all parts and materials used in a product.

**Patent** Grant of a property right to the inventor of an invention issued by the United States Patent and Trademark Office.

**Patent research** A popular form of intellectual property investigation.

**Pattern** In casting and forging, a form made of wood, metal, or other material around which a material is placed to make a mold.

**Pattern development (sheet metal)** Process based on laying out geometric forms in true size and shape flat patterns.

**Pattern features** In CADD, developed using an existing feature or group of features such as extrusions or holes.

**Patternmaker** Person who makes a pattern for casting and forging applications.

**PC** See Printed circuit.

**PCB** See Printed circuit board.

**PDM** See Product data management.

**Pen plotters** Printers that use liquid ink, felt, or roller-tip pens to reproduce the computer image on plotter bond paper, vellum, or polyester film.

**Penny** Weight classification for nails based on the number of pounds per 1000 nails.

**Pentagon** Five-sided polygon. Each side of a regular pentagon is equal and interior angles are all 108°.

**Perfluorocarbons (PFCs)** Group of powerful greenhouse gases with long atmospheric lifetimes; the greatest volume is emitted from industrial processes.

**Period** For the cam cycle, a segment of follower operations such as rise, dwell, and fall.

**Peripheral** An external computer hardware device that uses the computer to perform functions that the computer cannot handle.

**Permanent casting** Refers to a process in which a mold can be used many times.

**Perpendicular lines** Lines that intersect at a 90° angle.

**Perspective drawing** A form of pictorial drawing in which vanishing points are used to provide the depth and distortion that is seen with the human eye. Perspectives can be drawn using one, two, and three vanishing points.

**PF** See Powder forging.

**PFD** See Process flow diagram.

**Phantom lines** Thin lines made of one long and two short dashes that are alternately spaced.

**Phase gate design process** Idea that an imaginary gate at the end of each phase must be opened by completion of one or more tasks before one can continue.

**Philadelphia rod** Long pole with numbers and graduated sections that is used in surveying to determine elevation and distance.

**Photocopy printer** Machine for photographically reproducing written, printed, or graphic material, especially by xerography.

**Photodrafting** Combines photography with line work and lettering on a drawing.

**Pictorial** Related to pictures and representations by painting, drawing, or photograph. The intent of such drawings is for the image to look realistic.

**Pictorial assembly** Assembly used to display a pictorial rather than multiview representation of a product.

**Pictorial diagram** Diagram that represents the electrical circuit as a 3-D drawing.

**Pictorial drawing** Form of drawing that shows an object's depth. Three sides of the object can be seen in one view.

**Pie chart** Chart in which portions of a circle represent specific quantities or entities.

**Piercing point** Point where a particular line intersects a plane.

**Pilot relay** Systems controlled by communication devices and designated by the type of communication circuit or function of the relay system.

**Pinion gear** When two gears are mating, the smaller and usually driving gear.

**Pin numbers** External connectors that can be attached to other circuitry.

**Pintle and welded steel chains** Combination design between a detachable and an offset sidebar roller chain.

**Pipe drafting** Specialized field of pipe and fittings in several planes (depth) in an orthographic view.

**Pipe fittings** Fittings that allow a pipe to change direction and size and that provide for branches and connections.

**Pipelines** Large-diameter pipes that carry crude oil, water, petroleum products, gases, coal slurries, and a variety of liquids across hundreds of miles. Also known as *transportation piping*.

**Piping** Term that can refer to any kind of pipe used in a wide range of applications.

**Piping detail** Drawing that can be drawn for any connection, application, or installation that cannot be readily distinguished from other piping drawings.

**Piping drawings** Scale drawings that provide plans, elevations, and section views with all equipment, fittings, dimensions, and notes. Also known as *general arrangement (GA) drawings*.

**Piping isometric** Pictorial drawing that illustrates pipe runs in three-dimensional form.

**Piping specification** Subset of piping components that has been selected to meet the criteria for a set of given conditions, mainly design and operating pressures and temperatures, as well as the composition of the material being transported.

**Pitch** (1) A distance of uniform measure determined at a point on one unit to the same corresponding point on the next unit; used in threads, springs, and other machine parts. (2) For springs, one complete helical revolution or the distance from a point on one coil to the same corresponding point on the next coil. (3) For welds, the distance from one point on a weld length to the same corresponding point on the next weld when the weld is given in lengths spaced a given distance apart. (4) For a worm, the distance from one tooth to the corresponding point on the next tooth measured parallel to the worm axis; equal to the circular pitch on the worm gear.

**Pitch angle (bevel gear)** Angle between an element of a pitch cone and its axis.

**Pitch diameter** (1) For a belt, the effective diameter of the pulley, which is used to establish the speed ratio. (2) For a bevel gear, the diameter of the base of the pitch cone. (3) For a screw thread, a diameter measured from a point halfway between the major and minor diameter through the axis to a corresponding point on the opposite side. (4) For a spur gear, the diameter of an imaginary pitch circle on which a gear tooth is designed. Pitch circles of two spur gears are tangent.

**Pitch line** (1) For a belt, the only portion that does not change length as the belt bends around the pulley. The pitch line is used to determine the pitch diameter of the pulley. (2) For a rack, the line that is tangent to the pitch diameter on the gear pinion.

**Pixel** Acronym for *picture (pix) element (el)*. The number of pixels determines the resolution of the screen or the crispness of the image.

**PL** See Parts list.

**Placed features** CADD features added to existing features without using a sketch. Also known as *built-in*, *added*, or *automated* features.

**Plain bearing** Bearing based on a sliding action between mating parts; also called *sleeve* or *journal bearings*.

**Plane** Surface that is neither curved nor warped. Surface on which any two points may be connected by a straight line, and the straight line will always lie completely within the surface.

**Plane geometry** In its most basic definition, the geometry of 2-D objects.

**Plane of projection** Imaginary plane used in orthographic projection.

**Plastic** Any complex, organic, polymerized compound capable of being formed into a desired shape by molding, casting, or spinning. Have two types of structure: thermoplastic and thermoset. Also called *polymers*.

**Plastic resin identification codes** Numbers with arrows around them that indicate the type of plastic from which an item is made.

**Plat** Tract of land showing building lots.

**Plate cam** Cam in the shape of a plate or disk. The motion of the follower is in a plane perpendicular to the axis of the camshaft.

**Plated-through holes** Holes that have conductive material plated on the inside wall to form a conductive connection between layers of the circuit board.

**Plates** Flat pieces of steel of various thickness used at the intersection of different members and for the fabrication of custom connectors.

**Platinum** Element that is more rare and more expensive than gold. Industrial uses include applications that require corrosion resistance and a high melting point.

**PLM** See Product life cycle management.

**Plot device** Printer, plotter, or alternative plotting system to which a drawing is sent to create a hard copy.

**Plot plan** Plan that is drawn like a map, showing the relationship between the elements of the substation in correct orientation to compass direction.

**Plotting** The layout or drafting of a traverse by establishing the endpoints of bearings that enclose the traverse. In this sense, plotting should not be confused with plotting a drawing, such as making a hard copy when using a CADD system.

**Plotting (drawing)** In CADD, creating a hard copy of a drawing using a plotter.

**Plug tap** A tap with threads tapered to within five threads from the end. The plug tap can be used to completely thread through material or thread a blind note if full threads are not required all the way to the bottom.

**Plug valve** A valve with an opening that can be either rectangular or round and requires only a one-quarter turn to open and close. Also known as a *cock valve*.

**Plug weld** Weld made in a hole in one piece of metal that is lapped over another piece of metal.

**Plumbing** Refers to small-diameter pipes within residences that carry water, gas, and wastes.

**Plus-minus dimensioning** Dimensioning that uses a bilateral or unilateral tolerance format, depending on the application.

**Plywood** Wood composed of three or more layers of thin veneer sheets; the grains of the sheets are placed at 90° to each other and bonded together with glue.

**Plywood lumber beams** Engineered wood products that are made to precise specifications in size and nailing requirements for specific applications.

**Point of beginning (POB)** Any point that has been determined to be the beginning of a survey.

**Pocket pointer** Portable sharpener for mechanical pencils.

**Polar charts** Charts designed by establishing polar coordinate scales where points are determined by an angle and distance from a center or pole.

**Polar coordinate dimensions** Using combined angular and linear dimensions to locate features from planes, centerlines, or center planes.

**Polar coordinates** In CADD, a point located using the distance from a fixed point at a given angle. Can be an absolute polar coordinate measured from the origin or relative polar coordinates measured from the previous point. When preceded by the @ symbol, a polar coordinate is measured from the previous point. If the @ symbol is not included, the coordinate is located relative to the origin. When entering a polar coordinate in AutoCAD, the < symbol separates the two values and establishes that a polar or angular increment follows.

**Polyester film** High-quality drafting material with excellent reproduction, durability, and dimensional stability; also known by the trade name Mylar®.

**Polyester leads** For drawing on polyester drafting film. Also known as *plastic leads*.

**Polygonal modeling** Basic form of surface modeling that produces lower-quality surfaces without precise curvature control.

**Polygons** Enclosed figures such as triangles, squares, rectangles, parallelograms, and hexagons.

**Polyhedron** Solid formed by plane surfaces. The surfaces are referred to as *faces*.

**Polymerization** Process of joining two or more molecules to form a more complex molecule with physical properties that are different from the original molecules.

**Positive drive belts** Belts that have a notched underside that contacts a pulley with the same design on the circumference.

**Postprocessor** Integral piece of software that converts a generic CAM system tool path into usable CNC machine code (G-code).

**Postmortem review** Process used to assess the effectiveness of the project, project management, the product development process, and the project team.

**Postproduction review** Review conducted no more than 12 months after the start of production. Point when a company looks at the cost and profit margin and determines if the product does what was expected in the marketplace.

**Powder forging (PF)** Powder metallurgy process that places formed metal particles in a closed die where pressure and heat are applied.

**Powder metallurgy (PM)** Process that takes metal-alloyed powders and feeds them into a die, where they are compacted under pressure to form a desired shape. The compacted metal is then removed from the die and heated at temperatures below the metal's melting point.

**Power hacksaw** Saw used to cut a wide variety of materials.

**Power supply plan** Plan used to show all electrical outlets, junction boxes, and related circuits.

**Precast concrete** Forming a concrete component off-site at a fabrication plant and transporting it to a construction site.

**Precious metals** Metals of high value, including gold, silver, and platinum.

**Precision chains** Chains designed for smooth, free-running operation at high speeds and high power.

**Precision running fits** Fits that are as close as can be expected to run freely and are intended for precision work at slow speeds and light journal pressures.

**Predictive engineering** Engineering that uses a computer software prototype, rather than a physical prototype, and tests the function and performance of a product.

**Preproduction build** When a limited number of products are manufactured and assembled to validate the manufacturing process and to check final product conformance.

**Press break** Machine tool used to make bends in sheet metal.

**Pressure angle** Direction of pressure between contacting gear teeth. Determines the size of the base circle and the shape of the involute spur gear tooth, commonly 20°.

**Pressure regulators** Regulators used in steam processes that require a constant flow at a steady rate.

**Prestressed concrete** Concrete in which steel cables, wires, or bars are placed and held in tension as the concrete is poured around them.

**Primary auxiliary views** Views that are adjacent to and aligned with a principal view.

**Prime circle** Circle with a radius equal to the sum of the base circle radius and the roller cam follower radius.

**Prime meridian** Line of longitude that is given the zero-degree designation and from which all other lines of longitude are measured.

**Printed circuit (PC)** Electronic circuit printed on a board that forms the interconnection between electronic devices.

**Printed circuit artwork** An accurate, scaled, and undimensioned drawing used to produce the master pattern from which the actual board is manufactured.

**Printed circuit board (PCB)** A flat plate or base of insulating material containing a pattern of conducting material that becomes an electrical circuit when components are attached.

**Printer** Device that receives data from the computer and converts it into alphanumeric or graphic printed images.

**Prism** Geometric solid object with ends that are polygons of the same size and shape and sides that connect the same corresponding corners of the ends.

**Process and instrumentation diagram (P&ID)** Nonscale schematic diagrams that include more details about the instrumentation schematics to be used in the plant than found in a PFD.

**Process flow diagram (PFD)** Nonscale schematic diagram that illustrates the layout and composition of a system using symbols.

**Process piping** Piping used to transport fluids between storage tanks and processing equipment.

**Process vessels** Storage tanks found in a piping installation.

**Product bill of materials** Document created to determine the cost of a complete product. The bill of materials is used to get quotes through buyers or directly from suppliers and to estimate the cost of manufactured parts within a company or from subcontractors who make the parts for the product. Helps organize the manufacturing process.

**Product data management (PDM)** Process of organizing and monitoring data related to a product such as a drawing, model, specification, or other associated document.

**Product definition dataset** Collection of one or more computer files that provides graphical or textual presentations for the physical and functional description of an item.

**Product description and business case** Formal document that specifies the features, pricing, and costs of a new product.

**Product life cycle** Complete life of a product, including these stages: idea, planning and development, introduction to the marketplace, sales buildup, maximum sales, declining sales, and withdrawal from the marketplace.

**Product life cycle management (PLM)** Method of managing the entire life cycle of a product from the initial concept through development and manufacture to discontinuance or replacement.

**Profile** (1) Depiction of what a section of land (or utility pipe, etc.) looks like in elevation. (2) Geometric tolerances that control the form, orientation, or location of straight lines or surfaces, arcs, and irregular curves. Can be characterized as the outline of an object represented either by an external view or a cross section through the object. (3) A line that is parallel to the profile projection plane; its projection appears in true length in the profile view.

**Profile of a line** In GD&T, tolerance is a two-dimensional or cross-sectional geometric tolerance that extends along the length of the feature.

**Profile of a surface** In GD&T, tolerance is used where it is desired to control the entire surface as a single feature.

**Profile tolerance** Specifies a uniform boundary along the true profile within which the elements of the surface must lie.

**Projected tolerance zone** Position tolerance zone specified as the distance the fastener extends into the mating part, the thickness of the part, or the height of a press-fit stud.

**Projection line** Straight line at 90° to the fold line that connects the projection of a point in a view to the projection of the same point in the adjacent view.

**Projection plane** An imaginary surface on which the view of an object is projected and drawn. This surface is imagined to exist between the object and the observer.

**Project portfolio** Compilation of all potential new projects that are under consideration for implementation.

**Project portfolio management** Methodology that management uses to select projects for execution and the order in which they are completed.

**Proportional dividers** Manual drafting dividers used to reduce or enlarge an object without using mathematical calculations or scale manipulations.

**Prototype** Model or original design that has not been released for production.

**Public land system** Land divided by a rectangular system of surveys in which the main subdivisions are townships and sections.

**Pulleys** Wheels constructed with a groove in their circumference to match the shape of the belt and thus transmit power to the belt.

**Punching** (1) When a die penetrates a material to create a hole of a desired shape and depth; (2) to remove material by cutting away.

**Punch press** Machine used for punching and stamping.

**Purchase parts** See Standard parts.

**Pyramid prism** Prism with a regular polygon-shaped base and sides that meet at a single point called the *vertex*.

**Pythagorean theorem** States that the sum of the squares of two sides of a triangle equals the square of the hypotenuse:  $a^2 + b^2 = c^2$ .

## Q

**Quadrilaterals** Four-sided polygons that can have equal or unequal sides or interior angles.

**Quality function deployment (QFD)** Product and service planning process that starts and ends with input from customers. Customer feedback is the driving force behind the development requirements for a new or revised product or service. Also known as *voice of the customer (VOC)*.

**Quench** To cool suddenly by plunging into water, oil, or other liquid.

## R

**RA** See Return-air register.

**Rack** Straight bar with gear teeth used to convert rotary motion to reciprocating motion. Theoretically, a spur gear with an infinite pitch diameter.

**Radial element** Line element on the contour of a radial surface.

**Radial load** Load distributed around a shaft.

**Radial motion** Exists when path of motion forms a circle, the diameter of which is perpendicular to the center of a shaft; also known as *rotational motion*.

**Radiant heating and cooling systems** Systems that function on the basis of providing a comfortable environment by means of controlling surface temperatures and minimizing excessive air movement within the space.

**Radius (R)** Distance from the center of a circle to its circumference; always one-half the diameter.

**Radon** Naturally occurring radioactive gas that breaks down into compounds that can cause cancer when large quantities are inhaled over long periods of time.

**Random-access memory (RAM)** Most common memory used by software to perform necessary tasks while a computer is running.

**Rapid prototyping (RP)** Process of creating a physical and functional model from a computer-generated 3-D model using a rapid prototyping machine (also known as a *3-D printer*). RP machines are available that build prototypes from various materials such as paper and liquid polymer. Some manufactures use RP machines to build actual parts. *See also* Free-form fabrication process.

**Raster** Electron beam that generates a matrix of pixels.

**Rated horsepower** Horsepower specified on a driver motor.

**Ratio scales** Special scales referred to as *logarithmic* and *semilogarithmic*.

**Reaction injection molding process** Process used to fabricate large parts such as automobile dashboards and fenders. Polymer chemicals are mixed together under pressure and then poured into the mold where they react and expand to fill the mold.

**Real time** A computer program that creates events that are represented in time exactly as they occur.

**Ream** To enlarge a hole slightly with a machine tool called a *reamer* to produce greater accuracy.

**Rebar** Steel reinforcing bars used in reinforced concrete.

**Rebar schedules** Charts placed next to the detail that key to the drawing information about the rebar used in the detail.

**Rectangular coordinate dimensioning** Use of linear dimensions to locate features from planes, centerlines, and center planes.

**Rectangular coordinate dimensioning without dimension lines** Type of dimensioning that includes only extension lines and text aligned with the extension lines. Each dimension represents a measurement originating from datums or coordinates (*X*-, *Y*-, *Z*-axes).

**Rectangular pattern** CADD feature that copies and organizes an element into a designated number of rows and columns and places the features a specified distance apart from each other.

**Rectangular system of surveys** System of describing the land that is part of a public land survey. Each survey uses townships, sections, quarter sections, and so on to describe a particular piece of land.

**Rectilinear charts** Charts that are set up on a horizontal and vertical grid where the vertical axis identifies the quantities or values related to the horizontal values; also known as *line charts*.

**Reference arrow method** Alternate technique for placing the cutting- and viewing-plane lines.

**Reference designations** Tie components directly with the schematic drawing. A reference designation is a letter (or letters) identifying a component.

**Reference features** CADD construction points, lines, and surfaces that create reference elements anywhere in space to help position and generate additional features. Also known as *work features* and *reference geometry*.

**Reflected ceiling plan** Layout of a proposed suspended ceiling system.

**Refractory** Nonmetallic material that retains its strength under high temperatures.

**Refrigeration** Process based on the principle that a liquid changing to vapor absorbs large amounts of heat.

**Regular polygon** Polygon with equal sides and equal internal angles.

**Regular polyhedron** Solid object constructed of regular polygon surfaces.

**Regulating valve** Valve in which fluid travels in an S pattern, allowing the valve to maintain a close control on the flow and achieve a tight, positive shutoff. Also known as a *globe valve*.

**Regulatory approval** Part of the execution phase in which established institutions—normally, not-for-profit and for consumer protection—test a product with varying levels of intensity, depending on the product's purpose.

**Reinforced concrete** Concrete poured around steel bars placed in forms.

**Reinforced plastic** *See* Composite.

**Related part method** Use of phantom lines to show a part or parts that are next to the part being detailed.

**Related views** Two views adjacent to the same intermediate view.

**Release documentation** (1) Documentation that has made the transition from the development phase to the execution phase; (2) changes in documentation that occur between revisions of a product.

**Relief** Slight groove between perpendicular surfaces to provide clearance between the surfaces for machining.

**Relief valve** *See* Safety valve.

**Removed section** Sectional view taken from the location of the section cutting plane and placed in any convenient location of the drawing; generally labeled in relation to the cutting plane.

**Reprogrammable** When a robot's operating program can be changed to alter the motion of its arm or tooling.

**Research and development (R&D)** First phase used to determine the feasibility of new products or the evolution of existing products using creativity, market research, product research, and prototype development.

**Resin transfer molding** Process of placing reinforcing material into a mold and then pumping resin into the mold.

**Resistors** Components that contain resistance to the flow of electric current.

**Resolution** Number of pixels per square inch of a monitor; one element that determines image quality.

**Retaining rings** Rings available as fasteners to provide a stop or shoulder for holding bearings or other parts on a shaft or used internally to hold a cylindrical feature in a housing.

**Return-air register (RA)** Opening into which air flows from a room and into a return duct.

**Reverse engineering** Process of converting an existing physical product into drawings or digital models; involves discovering the technological principles of a device, object, or system through analysis of its structure, function, and operation.

**Revision** When parts are redesigned or revised for any reason and a drawing is changed.

**Revision cloud** Cloudlike circle around a change.

**Revision history block** Block that records changes to the drawing; located in the upper-right corner of sheet borderlines, although some companies use other placements. Also called the *revision block*.

**Revision status of sheets block** Block that appears on the first sheet of multiple-sheet drawings and records the revision status of each drawing. This block is not required on single-sheet drawings.

**Revolution** Alternate method for solving descriptive geometry problems in which the observer remains stationary and the object is rotated to obtain various views.

**Revolved section** Sectional view established by revolving 90° in place into a plane perpendicular to the line of sight; generally used to show the cross section of a part or feature that has consistent shape throughout the length.

**Rib** Thin metal section between parts that reinforce while reducing weight in a part.

**Right angle** Angle of 90 degrees.

**Right angle helical gears** See Cross-helical gears.

**Right triangles** Triangles with certain unique geometric characteristics. Two internal angles equal 90° when added. The side opposite the 90° angle is called the *hypotenuse*.

**Right-hand thread** Thread that engages with a mating thread by rotating clockwise or with a turn to the right when viewed looking toward the mating thread.

**Right-of-way** Refers to an easement or deeded strip of land for construction and maintenance of features such as roads, utilities, or other uses. Includes the surface, underground, and overhead space at the designated strip of land.

**Rim board** Board used to cap the ends of the I-joist construction just like the rim joist used in conventional framing systems.

**Rimmed steel** Steel cast with little or no degasification; has applications where sheets, strips, rods, and wires with excellent surface finish or drawing requirements are needed.

**Rise** Vertical movement when a cam is rotating and the follower is moving upward.

**Rivet** Metal pin with a head used to fasten two or more materials together.

**Robot** Reprogrammable multifunctional manipulator designed to move material, parts, tools, or specialized devices through variable programmed motions for the performance of a variety of tasks. This process is called *robotics*.

**Rocker** Link that moves back and forth through an angle; also known as a *lever*.

**Rocker arm** Different from a rocker because it has a pivot point near the center and oscillates through a given angle.

**Rockwell hardness test** Performed using a machine that measures hardness by determining the depth of penetration of a spherically shaped device under controlled conditions.

**Rolled thread** Thread forms used for screw shells of electric sockets and lamp bases.

**Roller bearing** Bearing composed of two grooved rings and a set of rollers. The rollers are the friction-reducing element.

**Roller follower** Feature that works well at high speeds, reduces friction and heat, and keeps wear to a minimum.

**Roll form** Form that creates a curved sheet metal feature in a linear application on flat material or around an axis.

**Roof drainage plan** Plan that shows the elevations of a roof and provides for adequate water drainage; generally associated with low slope and flat roofs.

**Roof framing details** Details required to show the construction methods used at various member intersections in the building.

**Roof framing plan** Showing major structural components in plan view that occur at the roof level.

**Root** The bottom of external and the top of internal screw threads.

**Root diameter (spur gear)** Diameter of a circle coinciding with the bottom of the tooth spaces.

**Root opening (weld)** Given distance that two pieces of metal are spaced apart.

**Rotational bearings** Bearings used for radial loads.

**Rotational molding process** Process typically used to produce large containers such as tanks, hollow objects such as floats, and other similar types of large, hollow products. Works by placing a specific amount of polymer pellets into a metal mold.

**Round** Two or more exterior surfaces rounded at their intersection.

**RP** See Rapid prototyping.

**Rubber** Elastic hydrocarbon polymer that occurs naturally as a milky emulsion known as *latex* in the sap of some plants but that can also be produced synthetically.

**Runner** Passageway for molten metal to be poured into the cavity of a casting.

**Running and sliding fits** Fits intended to provide a similar running performance with suitable lubrication allowance throughout their range of sizes.

**Runout** (1) In GD&T, a combination of controls that can include the control of circular elements of a surface, the control of the cumulative variations of circularity, the control of variations in perpendicularity and flatness, and straightness, coaxiality, angularity, taper, and profile of a surface. (2) In multiviews, characteristics of intersecting features determined by locating the line of intersection between the mating parts. (3) For screw threads, refers to circular runout of major or minor cylinders with respect to the pitch cylinder. Also see *Vanish*.

## S

**Safety valve** Valve that keeps pressures at or below a given point. Also called a *relief valve*.

**Sand casting** Most commonly used method of making castings. There are two general types of sand castings: green sand and dry sand molding.

**Sandpaper block** or **sanding block** Piece of sandpaper stapled to a wooden paddle.

**Saw machine** Machine that can be used (1) as a cutoff tool to establish the length of material for further machining or (2) to perform certain machining operations such as cutting a narrow slot called a *kerf*.

**Scale** Instrument with a system of ordered marks at fixed intervals used as a reference standard in measurement. A scale establishes a proportion used to determine the dimensional relationship of an actual object to the representation of the same object on a drawing.

**Scale factor** Reciprocal of the drawing scale; used in the proper scaling of various objects such as text, dimensions, and graphic patterns.

**Scanning** Method of reproducing existing hard copy drawings in the form of computer drawings.

**Schedules** HVAC charts of materials or products that include size, description, quantity used, capacity, location, vendors' specifications, and any other information needed to construct or finish the system.

**Schedule tracking** Establishing a system that prioritizes and organizes work to be done through manufacture, assembly, packaging, and shipping of a product.

**Schematic diagram** Drawing of a series of lines and symbols that represent the electrical current path and components of a circuit. Provides the basic circuit connection information for electronic products or substations.

**Schematic representations (threads)** Showing threads as symbols rather than as they actually look.

**Schematic wiring diagram** Diagram that combines the simplicity of a schematic diagram with the completeness of a wiring diagram.

**Screen cursor** On-screen symbol used to point and select on-screen; usually an arrow, box, or crosshair.

**Screw machine** Type of lathe that is specialized for the automated mass production of small parts.

**Screw thread insert** Helically formed coil of diamond-shaped wire made of stainless steel or phosphor bronze.

**Screw threads** Common terminology for threads that are used as fasteners. Helical or conical spirals formed on the external surface of a shaft or internal surface of a cylindrical hole.

**Sealed bearing** Bearing with seals made of rubber, felt, or plastic placed on the outer and inner rings of the bearing.

**Seam** Line formed when two or more edges come together.

**Seam weld** Another type of resistance weld that is a continuous weld made between or on overlapping members.

**Seamless pipe** Pipe created by piercing a solid billet and rolling the resulting cylinder to the required diameter.

**Secondary auxiliary view** View that is adjacent to and projected from a primary auxiliary view or from another secondary auxiliary view.

**Secondary** or **second-generation original** Print of an original drawing that can be used as an original.

**Section line** Thin line used in the view of a section to show where the cutting-plane line has cut through material.

**Sectional view** View used to describe the interior portions of an object that are otherwise difficult to visualize. Interior features that are described using hidden lines are not as clear as if they are exposed for viewing as visible features.

**Sectioning** Process of creating a sectional view.

**Section** See Sectional view.

**Self-clinching fastener** Any device, usually threaded, that displaces the material around a mounting hole when pressed into a properly sized drilled or punched hole.

**Self-clinching nut** Nut that features thread strengths greater than those of mild screws; is commonly used wherever strong internal threads are needed for component attachment or fabrication assembly.

**Self-clinching spacers and standoffs** Devices used when components must be spaced or stacked away from a panel.

**Self-clinching stud** Externally threaded self-clinching fastener that is used where the attachment must be positioned before being fastened.

**Self-tapping screw** Screw designed for use in situations where the mating thread is created by the fastener.

**Semiconductor** Device that provides a degree of resistance in an electronic circuit; types include diodes and transistors.

**Semipictorial wiring diagram** Two-dimensional images of components in a diagram form for use in electrical or electronic applications.

**Sepias** Diazo materials used to make secondary originals.

**Service factor (belts)** Value determined by the type of machinery, number of hours of daily operation, and type of driven unit.

**Service mark** Same as a trademark except that it identifies and distinguishes the source of a service rather than a product.

**Set of structural drawings** Representative drawings that may include a floor plan, a foundation plan and details, a concrete slab plan and details, a roof framing plan and details, a roof drainage plan, building section(s), exterior elevations, and a panel plan, elevations, and wall details. Not all complete sets of structural drawings contain the same number of sheets or type of information.

**Set of working drawings** See Working drawing.

**Set screws** Screws used to help prevent rotary motion and to transmit power between two parts such as a pulley and shaft.

**Shale** Fine-grained rock composed of flakes of clay minerals and tiny fragments of other minerals such as quartz.

**Shaper** Machine used primarily to produce horizontal, vertical, or angular flat surfaces. Generally becoming out of date and rapidly being replaced by milling machines.

**Sharp-V thread** Although not commonly used, a thread that fits and seals tightly.

**Sheaves** Same as pulleys except that sheaves are generally the drive and pulleys are the driven.

**Sheet metal drafting** Drafting found in any industry where flat material is used for fabrication into desired shapes.

**Shield** Metal plate on one or both sides of a bearing. Act to keep the bearing clean and retain lubricant.

**Shop drawings** Drawings that break each individual component of a structural engineering drawing down into its fabrication parts.

**Shrink fit** See Interference fit.

**Silk screen artwork** Separate sheet of circuit board artwork containing component outlines and orientation symbols.

**Silver** Metallic element often alloyed with 8% to 10% copper for use in jewelry and coins.

**Simple harmonic motion** Motion that can be used for high-speed applications if the rise and fall are equal at 180°.

**Simplified representations** Easy and quickly drawn representations that clearly describe threads.

**Simulated datum** Point, axis, line, or plane consistent with or resulting from processing or inspection equipment such as a surface plate, inspection table, gage surface, or mandrel.

**Simulated datum axis** Axis of a perfectly cylindrical inspection device that contacts the datum feature surface.

**Simulation** Refers to the use of a computer-generated system to represent behavior of a proposed system.

**Single-layer board** Board that contains all printed wiring on one side with the components on the opposite side.

**Single lead** (1) Thread that engages one pitch when rotated 360°. (2) Worm feature that advances one pitch with every revolution.

**Single limit** Limit used when a specified dimension cannot be any more than the maximum or less than the minimum given value.

**Single-row ball bearings** Bearings designed primarily for radial loads, although they can accept some thrust loads.

**Sintering** Heating process used in plastic molding and powder metallurgy that forms a bond between the plastic or metal powder particles.

**Site plan** See Plot plan.

**Six Sigma** Business management strategy originally developed in 1981 by Motorola, USA. Seeks to improve the quality of process outputs by identifying and removing causes of defects and minimizing manufacturing variables by using quality management methods. Creates special network of people within a company who are experts in the use of these methods.

**Size dimensions** Dimensions placed directly on a feature to identify a specific size; may be connected to a feature in the form of a note.

**Sketch** In CADD, 2-D or 3-D geometry that provides the profile or guide for developing sketched features.

**Sketched features** CADD features built from sketches such as extrusions, revolutions, sweeps, and lofts.

**Sketching** Freehand drawing without the aid of drafting equipment.

**Skew lines** Lines that are neither parallel nor intersecting.

**Slab** Concrete floor system, typically made of poured concrete at ground level.

**Slack side** Belt on the top of a drive.

**Slider** Link that moves back and forth in a straight line.

**Slider crank** Linkage mechanism that is commonly used in machines such as engine pistons, pumps, and clamping devices where a straight line motion is required.

**Sliding fits** Fits that are intended to move and turn easily but are not intended to run freely and, in larger sizes, may seize with small temperature changes.

**Slope angle** Angle in degrees that the line makes with the horizontal plane.

**Smelters** Facilities that do smelting, the process of melting or fusing ores in order to separate the metallic components.

**Socket weld** Form of pipe connection in which a plain-end pipe is slipped into a larger opening or “socket” of a fitting. One exterior weld is required, so no weld material protrudes into the pipe.

**Soft copy** Electronic data file of a drawing or model.

**Soft metric conversion** Preferred metric construction standard that rounds off dimensions to convenient metric modules.

**Software** Program or instructions that enable a computer to perform specific functions to accomplish a task.

**Software piracy** Unauthorized copying of software.

**Solder** Alloy of tin and lead.

**Soldered connection** Connection created by heating solder until it melts into a joint and hardens as it cools.

**Solder mask** Polymer coating to prevent the bridging of solder between pads or conductor traces on a printed circuit board. Also called *solder resist mask*.

**Solder paste** Paste that holds or glues components in place on the surface of a printed circuit board.

**Solid height** Maximum compression possible in a spring.

**Solid imaging** See Free-form fabrication process and Rapid prototyping.

**Solid length** See Compression length.

**Solid modeling** Design and engineering process in which a 3-D model of an actual part is created on-screen as a solid part showing no hidden features.

**Solid models** Model in CADD that contains information about object edges, the intersection of those edges and surfaces, and data about object volume and mass.

**Solid phase forming process** Process used to make plastic products with detailed shapes. Works by placing material into an initial hot die where it takes the preliminary shape. As the material cools, a die that matches the shape of the desired product forms the final shape.

**Solid primitives** In CADD, objects such as boxes, cones, spheres, and cylinders that are combined, subtracted, and edited to produce a final model.

**Space diagram** Drawing of a vector system that shows the correct direction and sense but is not drawn to scale.

**Span** Horizontal distance between two supporting members.

**SPC** See Statistical process control.

**Specification** (1) Exact statement describing the characteristics of a particular aspect of a project. (2) Any written information or instructions included in a drawing or with a set of drawings that gives all necessary information not shown in the drawing field, including such items as quality requirements; manufacturer name, type, part number, and details for purchase parts or material applications and finishes; and instructions defining the manner in which work is to be done. When possible, specifications are commonly included with the general notes. (3) Documents that accompany the drawings and contain all pertinent written information.

**Specific notes** See Local notes.

**Specified dimension** Part of the dimension from which limits are calculated.

**Specified tolerance** Tolerance applied directly to a dimension.

**Specs** Commonly used term to refer to specifications.

**Sphere** Three-dimensional ball shape. All points on the surface of a sphere are equidistant from the center.

**Spherical radius** Element preceded by the symbol SR, which is the radius of a sphere.

**Spherical roller bearings** Bearings that offer the best combination of high load capacity, tolerance to shock, and alignment and are used on conveyors, transmissions, and heavy machinery.

**Spindle** A rotating shaft.

**Spiral gears** See Cross-helical gears.

**Spiral torsion spring** Spring made by winding flat spring material into a coil in the form of a spiral.

**Spline** (1) With gears, one of a series of keyways cut around a shaft and mating hole; generally used to transfer power from a shaft to a hub while allowing a sliding action between the parts. (2) In geometry, a curve that uses a series of control points and other mathematical principles to define the curve's location and form.



**Split pattern** Form used in sand casting; sand is pounded or pressing sand around the form to create a specific shape.

**Spool drawing** Drawing usually drawn in 2-D or orthographically; shows all of the pipe and fittings needed to assemble a segment of piping.

**Spool sheets** Assembly drawings that contain complete dimensions and a bill of materials (BOM) that indicates the exact size and specifications for each fitting.

**Spot welding** Process of resistance welding in which base materials are clamped between two electrodes and a momentary electric current produces the heat for welding at the contact spot.

**Spotface** Used to provide a flat bearing surface for a washer face or bolt head.

**Spring** Mechanical device, often in the form of a helical coil or flat, that yields by expansion or contraction because of pressure, force, or applied stress.

**Spring index** Ratio of the average coil diameter to the wire diameter.

**Sprockets** Toothed wheels in chain drive applications that mate with a chain to transmit power from one shaft to another.

**Sprue** Passageway for molten metal to be poured into the cavity of a casting.

**Spur gear** Simplest, most common type of gear used to transmit motion between parallel shafts. Its teeth are straight and parallel to the shaft axis.

**Square groove weld** Weld applied to a butt joint between two pieces of metal.

**Square thread** Thread with a longer pitch than a Unified thread; developed as a thread that would effectively transmit power.

**Stadia** Technique of measuring distance using a Philadelphia rod and level.

**Stainless steels** High-alloy chromium steels that have excellent corrosion resistance and contain at least 10.5% chromium; some classifications have between 4% and 30% chromium.

**Stamping** Process that produces sheet metal parts by the quick downward stroke of a ram die that is in the desired shape.

**Stamping press** Metalworking machine tool used to shape or cut metal by deforming it with a die.

**Standard parts** Items that can be purchased from an outside supplier more economically than they can be manufactured; also known as *purchase parts*.

**Standards** Guidelines that specify drawing requirements, appearance, and techniques, operating procedures, and record-keeping methods.

**Static load** Type of load that maintains the same direction and degree of force during operation.

**Statics** Study of physics dealing with nonmoving objects acting as weight.

**Static sealing** Refers to stationary devices that are held in place and stop leakage by applied pressure. Static seals such as gaskets do not come in contact with the moving parts of the mechanism.

**Station point** In surveying, a fixed point from which measurements are made.

**Statistical process control (SPC)** Method of monitoring a process quantitatively and using statistical signals to either change a process or leave it alone.

**Statistical tolerancing** The assignment of tolerances to related dimensions in an assembly based on the requirements of statistical process control.

**Steel** Metal alloy of iron containing 0.8% to 1.5% carbon.

**Steel alloys** Alloys used to increase such properties as hardness, strength, and resistance to corrosion, heat, and wear.

**Steel castings** Used for machine parts where the use requires heavy loads and the ability to withstand shock.

**Steel pipe** Commonly used structural element for columns and bracing.

**Steel studs** Lightweight, noncombustible, corrosion-resistant framing for interior partitions and load-bearing exterior walls as high as four stories.

**Stereolithography** See Free-form fabrication process and Rapid prototyping.

**Stitch lines** Lines used to indicate the location of a stitching or sewing process.

**Stock size** Commercial or premanufactured size such as a particular size of square, round, or hex steel bar.

**Storage device** Component that contains or accepts media on which computer files are kept temporarily or permanently.

**Storage** Refers to disks and drives that allow an operator to store programs, drawing files, symbols, and data.

**Storyboarding** Process by which the key events of an animation are sketched out.

**Straight line segment** Line of any given length.

**Straight line motion** See Constant velocity motion.

**Straightness** Condition in which an element of a surface or an axis is in a straight line.

**Stressed skin panels** Panels that use solid lumber or engineered lumber stringers and headers with a plywood skin on the top and bottom.

**Stretch-out line** Typically, the beginning line on which measurements are made and the pattern development is established.

**Stroke** Distance the slider in a linkage travels from extreme left to extreme right position.

**Structural engineer** Works with architects and building designers to engineer the structural components of a building.

**Structural engineering drawings** Drawings that show in condensed form the final results of structural designing. Drawings, general notes, schedules, and specifications serve as instructions to a contractor.

**Structural tees** Tees produced from W, S, and M steel shapes.

**Structural tubing** Tubing manufactured in square, rectangular, and round cross-sectional configurations.

**Subassembly** Assembly that is added to another assembly.

**Subdivision** Tract of land divided into residential lots.

**Substation** The part of an electrical transmission system where electricity is switched or transformed from a very high voltage to a conveniently usable form for distribution to homes or businesses.

**Supervisory control relays** Relays used to check, monitor, or control other devices.

**Supply chain** Network of company relationships that support materials, information, and funds flowing from the supplier of a firm's supplier to its customer's customer. Also called *value chain*.

**Surface** Outer boundary of an object that connects to edges and vertices.

**Surface charts** Designed to show values represented by the extent of a shaded area; also known as *area charts*.

**Surface finish** Refers to the roughness, waviness, lay, and flaws of a machine surface.

**Surface model** CADD model that contains information about object edges, vertices, and surfaces.

**Surface mount technology (SMT)** Where the traditional component lead through is replaced with a solder paste to hold the electronic components in place on the surface of the printed circuit board; takes up to less than one-third of the space of conventional PC boards.

**Surface texture or surface finish** Intended condition of material surface after manufacturing processes have been implemented. Surface texture includes such characteristics as roughness, waviness, lay, and flaws.

**Sustainable design** Concept of developing products, structures, and services that are environmentally and socially responsible and economically practical. *See also* Green building.

**Sustainability** Refers to something that can last or is able to be maintained for long periods of time without damaging the environment or without depleting a resource.

**Swaging** Forming metal by using concave tools or dies that result in a reduction in material thickness.

**Swing check valve** Valve with an inner disc that operates by gravity or disc weight.

**Symbol library** Collection of symbols that can be used on any drawing.

## T

**Table** Arrangement of rows and columns to organize data for easier reading.

**Tabular** Refers to anything, such as a list, arranged in table form. Tabular lists can be parametrically associated to the documents from which they are created. For example, an item on a drawing can be associated to the list, and any change made to one automatically effects the other.

**Tabular dimensioning** Form of rectangular coordinate dimensioning without dimension lines in which size and location dimensions from datums or coordinates (*X*-, *Y*-, *Z*-axes) are given in a table identifying features on the drawing.

**Tail** Line added to a welding symbol when it is necessary to designate the welding specification, procedures, or other supplementary information needed to fabricate the weld.

**Tangent** Straight or curved line that intersects a circle or arc at one point only and is always 90° relative to the center.

**Tangent plane** Plane that contacts the high points of a specified feature surface.

**Tap** Machine tool commonly used to cut internal threads.

**Tap drill** Drill used to make a hole in material before tapping.

**Taper** Conical shape on a shaft or hole or the slope of a plane surface.

**Tapered roller bearings** Bearings used in gear reducers, steering mechanisms, and machine tool spindles.

**Taper pin** Pin used for parts that have to be taken apart frequently or where removal of straight dowel pins can cause excessive hole wear.

**Taper tap** Tap generally used to start a thread. The threads are tapered to within ten threads from the end.

**Tap set** Made of a taper tap, plug tap, and bottoming tap.

**Technical illustration** Involves use of a variety of artistic and graphic arts skills and a wide range of media in addition to pictorial drawing techniques.

**Technical pen** Pen that functions on capillary action, with a needle acting as a valve to allow ink to flow from a storage cylinder through a small tube, which is designed to meter the ink so a specific line width is created. Also known as a *technical fountain pen*.

**Tempering** Process of reheating normalized or hardened steel to a specified temperature, followed by cooling at a predetermined rate to achieve certain hardening characteristics.

**Template** (1) In manual drafting, plastic sheets with very accurate shapes are cut out and used as stencils for drawing shapes. (2) In undimensioned drawings, a dimensionally stable tool that is a full-size reproduction defining the true profile of the part. (3) For CADD, *see* File template.

**Tensile forces** Forces that pull away.

**Tensile strength** Ability to be stretched.

**Terminal unit** In HVAC, an air valve that has a heating coil, with the valve opening and closing based on the heat requirement for that particular terminal unit as determined by the controlling thermostat.

**Text** In CADD, lettering; also called *attributes*.

**Text editor** Area provided by the text system where type is entered and adjusted.

**Thermoforming of plastic** Process used to make all types of thin-walled plastic shapes. The process works by taking a sheet of material and heating it until it softens and sinks down by its own weight into a mold that conforms to the desired final shape. Vacuum pressure is commonly used to suck the hot material down against the mold.

**Thermoplastic** Plastic material can be heated and formed by pressure. On reheating, the shape can be changed.

**Thermoset** Plastics that are formed by heat and pressure into permanent shapes that cannot be altered after curing.

**Thermostat** Automatic mechanism for controlling the amount of heating or cooling given by a central or zoned heating or cooling system.

**Third-angle projection** Method of view arrangement commonly used in the United States.

**Thread** Part of a screw thread represented by one pitch.

**Threaded fasteners** Any thread form that can be used to fasten two or more features or parts together.

**Threaded rod** External thread can be machined on a fastener such as a hexagon head bolt or on a shaft without a head.

**Thread form** Design of a thread determined by its profile.

**Thread insert** *See* Screw thread insert.

**Thread note** Information that clearly and completely identifies a thread.

**Thread series** Groups of common major diameter and pitch characteristics determined by the number of threads per inch.

**Threads per inch** Number of threads measured in 1 in. The reciprocal of the pitch in inches.

**Three-dimensional (3-D)** Object having width, height, and depth dimensions.

**Three-dimensional (3-D) printing** Creates parts by printing successive layers of material; least-expensive PR process. *See also* Stereolithography.

**Thrust bearings** Bearings designed for use only in thrust load situations.

**Thrust loads** Lateral loads that apply force to the end of a shaft.

**Ties (structural)** Ties that are wrapped around vertical steel in a column or placed horizontally in a wall or slab to help keep the structure from separating; also keep rebar in place while the concrete is being poured into forms.

**Tight side (belt)** Belt normally on the bottom of the drive when the driver and driven shafts are in horizontal alignment.

**Tilt-up construction** Construction method that uses formed wall panels that are lifted or tilted into place.

**Timing** The regulation of occurrence, rate, or coordination of a mechanism such as the synchronization of a cam's rotation to achieve a desired effect.

**Titanium** Metallic element with many uses in the aerospace and jet aircraft industries because it has the strength of steel, the approximate weight of aluminum, corrosion resistance, and heat resistance up to 800°F (427°C).

**Tolerance** Total permissible variation in a size or location dimension.

**Tolerance stacking** When the tolerance of each dimension builds on the next. Also called *tolerance buildup*.

**Tool** Specially designed and built manufacturing aid, normally in production, that is used to assist an operator in the manufacture of specific parts.

**Tool design** Involves kinematics, machining operations, machine tool function, material handling, and material characteristics. Also known as *jig and fixture design*.

**Tool palettes** In CADD, similar to floating toolbars; contain often-used block symbols and patterns that can be used in a drawing. Toolbars contain various buttons that activate commands. Tool palettes are customizable with blocks and patterns to suit specific needs.

**Tool runout** Distance a tool can go beyond the required full thread length.

**Top-down design** Design approach in which an assembly controls or produces individual components.

**Topography** The physical description of land surface showing its variation in elevation and locating other features.

**Torque** Turning force around an axis.

**Torsion** Twisting forces placed on a feature.

**Torsion bar spring** Straight bar or rod used to provide resistance to a twisting movement around a longitudinal axis.

**Torsion springs** Springs designed to transmit energy by a turning or twisting action.

**Total quality management (TQM)** Philosophy that calls for the integration of all organizational activities to achieve the goal of serving customers.

**Total runout** In GD&T, provides a combined control of surface elements used to control the combined variations of circularity, straightness, coaxiality, angularity, taper, and profile when applied to surfaces constructed around and at right angles to a datum axis.

**Toyota production system (TPS)** System that recognizes the interaction between people and technology in the workplace.

**Trackball** Input device consisting of a smooth ball mounted in a small box. A portion of the ball protrudes above the top of the box and is rotated with the hand to move the on-screen cursor.

**Trademark** A word, phrase, symbol or design or a combination of words, phrases, symbols or designs that identifies and distinguishes the source of the goods or services of one party from those of others.

**Transfer molding** Similar to compression molding for thermoset plastic products. In this process, the material is heated and then forced under pressure into a mold.

**Transistors** Semiconductor devices in conducting and resisting electron flow; used to transfer or amplify an electronic signal.

**Transit line (civil)** Any line of a survey established by a transit or other surveying instruments.

**Transition piece** Duct component that provides a change from square or rectangular to round; also known as a *square to round*.

**Translation** In CADD, occurs when converting data from one system's file format to another's format; often necessary when sharing CADD data with others, such as consultants, manufactures, and vendors.

**Translational motion** Linear motion.

**Traverse** In surveying, a series of lines with directions and lengths that are connected at station points.

**Triangle** Geometric figure formed by three intersecting lines creating three angles.

**Triangulation** Technique used to lay out the true size and shape of a triangle with the true lengths of the sides; used in pattern development on objects such as the transition piece.

**Trilinear chart** Chart designed in the shape of an equilateral triangle; used to show the interrelationship between three variables on a three-dimensional diagram.

**Trimetric drawing** Type of pictorial drawing in which all three principal axes do not make equal angles with the plane of projection.

**True azimuth** Azimuth measured from the actual north or south pole.

**True geometry view** View that shows the actual true size and shape of an object.

**True length** When the line of sight is perpendicular to a line.

**True position** In GD&T, the theoretically exact location of a feature established by basic dimensions.

**True profile** In GD&T, the actual desired shape of the object is the basis of the profile tolerance and should be defined by basic dimensions in most applications.

**True size and shape** When the line of sight is perpendicular to a surface or feature.

**Trunk lines** Wiring lines merge at convenient locations into this main line, which runs horizontally or vertically between component symbols. Also called *highways*.

**Tubing** Small-diameter pipe that is often flexible, thus eliminating the need for many common fittings.

**Tungsten** Element that has been used extensively as the filament in lightbulbs because of its high melting point and ability to be drawn into very fine wire.

**Turning point** In surveying, the point at which the Philadelphia rod is placed and measured.

**Turret** Device used in mass-production manufacturing where one machine setup must perform several operations.

**Turret lathe** Lathe designed to carry several cutting tools in place of the lathe tailstock or on the lathe carriage.

**Two-dimensional (2-D)** View having only width and height, width and length, or height and length dimensions.

## U

**UCL** See Upper control limit.

**Ultrasonic machining** Process in which a high-frequency mechanical vibration is maintained in a tool designed to a desired shape; also known as *impact grinding*.

**Underconstrained** A CADD design that includes constraints that are not enough to size and locate all geometry.

**Undercut** Neck machined in which an external thread meets a fastener head or larger diameter shaft. The undercut is used to eliminate the possibility of a machine radius at the head and to allow for a tight fit between the thread and the head when assembled.

**Undimensioned drawings** Engineering drawings that are created to an exact scale from which a designed part and associated tooling are produced directly by photographic processes or other processes.

**Unidirectional dimensioning** Dimensioning that requires all numerals, figures, and notes to be lettered horizontally and read from the bottom of the drawing sheet.

**Unified numbering system (UNS)** Identification numbering system for commercial metals and alloys.

**Unified threads** Most common threads used on threaded fasteners.

**Uniform accelerated motion** Constant acceleration for the first half of the rise and constant deceleration for the second half of the rise.

**Uniform resource locator (URL)** Internet address usually consisting of an access protocol (http), domain name (www.delmarlearning.com), and, optionally, the path to a file or resource found on a server—for example, http://www.delmarlearning.com.

**Unilateral tolerance** Tolerance in which variation is permitted in only one direction from a specified dimension.

**Universal milling machine** Machine with table action that includes X-, Y-, and Z-axis movement plus angular rotation. Looks much the same as other milling machines but has the advantage of additional angular table movement.

**UNLESS OTHERWISE SPECIFIED** Statement often placed with notes to remind a reader that a given specification generally applies but can be modified by other information provided on the drawing or in other documents.

**UNS** See Unified numbering system.

**Unspecified tolerances** Tolerances applied to dimensions on a drawing that is read without tolerances. The tolerances for these dimensions relate to general tolerances found in a note or in the title block.

**Upper control limit (UCL)** The higher expected variation of the sample averages in the SPC system.

**Upset** Forging metal used to form a head or enlarged end on a shaft by pressure or hammering between dies.

**Upset forging** Process of forming metal by pressing along the longitudinal dimension to decrease length while increasing width.

**URL** See Uniform resource locator.

**USB flash drive** Compact and easy-to-use device similar in use to a computer hard drive. USB flash drives can be slipped into a pocket or put on a keychain for ultimate portable storage, providing complete freedom and mobility. Drives currently can hold up to two gigabytes of data, or about three times the content of a standard compact disc. Great for storing personal information and can be used instead of a computer's hard drive.

## V

**Vacuum bag forming** Using vacuum pressure to force a thin layer of sheet-reinforced polymer around a mold.

**Value** Any necessary activity or process that a customer is willing to pay for the resulting product.

**Value chain** See Supply chain.

**Valve** Any mechanism such as a gate, ball, flapper, or diaphragm used to regulate the flow of fluids through a pipe.

**Vanish thread** That portion of the incomplete thread that is not fully formed at root or at crest and root. Vanish is produced by the chamfer at the starting end of the thread forming tool. Also referred to as a *partial thread*, *washout thread*, or *thread runoff*.

**Variables** Value that varies.

**V belts** Most commonly used belts. Have a wide range of applications and operating conditions.

**Vector analysis** Branch of mathematics that includes the manipulation of vectors.

**Vector diagram** Vector system drawing in which vectors are drawn with the correct magnitude and sense and to scale.

**Vector quantity** Quantity that requires both magnitude and direction for its complete description.

**Vellum** Drafting paper with translucent properties that is specially designed to accept pencil or ink.

**Vent holes** Established in a casting to allow for gases, impurities, and metal to escape from the cavity.

**Verification** The process of determining whether the results of an analysis fulfill design requirements.

**Vernier** or **vernier scale** Small, movable auxiliary graduated scale attached parallel to a main graduated scale, calibrated to indicate fractional parts of the subdivisions of the larger scale, and used on certain precision instruments to increase accuracy in measurement.

**Vertex** Point where lines or edges intersect.

**V groove weld** Weld formed between two adjacent parts when the side of each part is beveled to form a groove between the parts in the shape of a V.

**View tools** Tools that allow a view of a drawing in a variety of ways but that do not actually modify the size, location, or shape of drawing objects. Do not confuse zoom or any other view tool with the commands used to edit a drawing.

**Viewing-plane line** Represents the location of where a view is established.

**Virtual** Something that appears to have the properties of a real or actual object or experience.

**Virtual condition** In GD&T, the combined maximum material condition and geometric tolerance, which is a boundary that takes into consideration the combined effect of feature size at MMC and geometric tolerance.

**Virtual design** Design form in which work is stored in a file in which the information remains integrated, up to date, and easy to manage.

**Virtual reality (VR)** A world that appears to be a real world, having many of the properties of a real or actual world.

**Virtual team** Team in which members are not physically together but are connected by distance communication technologies such as videoconferencing and e-mail.

**Viscosity** Internal friction of a fluid; measure of its resistance to flow.

**Visible line** Line that describe the visible surface or edge of the object. Visible lines are also called *object lines* or *outlines*.

**Visualization** Process of recreating a three-dimensional image of an object in a person's mind.

**Voice of the customer (VOC)** Customer feedback as the driving force behind the development requirements for a new or revised product or service.

**Volute spring** Conically shaped compression spring made of rectangular cross-section material.

**VR** See Virtual reality.

**Vulcanization** Heating material in a steel mold to form a desired shape.

## W

**Walk-through** Characterized as a camera in a computer program that is set up like a person walking through a building, around a product or building, or through a landscape. See also Fly-through.

**Wall details** Show the connection points of concrete panels used in tilt-up construction and connection details at the walls for other types of structures.

**Washer** Flat, disc-shaped object with a center hole that allows a fastener to pass through.

**Waste** Any activity that consumes time, resources, or space but does not add any value to the product or service.

**Water-jet cutting** Computer-controlled water jet (55,000 psi) used on composite materials and thin metals.

**Wave spring** Also known as *flat wire compression spring*, these springs have an overall length and operating height significantly less

than that of standard compression springs, and they can reduce the size of an assembly by as much as 50%.

**Wave solder** Common method of attaching components to printed circuit boards. A wave of molten solder is passed over the noncomponent side of the board, making all solder connections. A polymer coating, called a *solder mask* or *solder resist mask*, is applied to the board, covering all conductors except pads, connector lands, and test points. Solder masks are used to prevent the bridging of solder between pads or conductor traces, to cut down on the amount of solder used, and to reduce the weight of the board.

**Web** See Rib.

**Weld-all-around** Symbol attached to the reference line at the junction of the leader when a welded connection must be performed all around a feature.

**Welded pipe** Pipe formed from plate steel. The edges are welded together in a lap weld or a butt weld.

**Welded wire reinforcement** Steel wires spaced a specified distance apart in a square grid and welded together.

**Welding** Process of joining two or more pieces of like metals by heating the material to a temperature high enough to cause softening or melting.

**Welding specification** Detailed statement of the legal requirements for a specific classification or type of product.

**Weld length** Length of a weld that is not continuous.

**Weldment** An assembly of parts welded together.

**Weld symbol** Indicates type of weld; part of the welding symbol.

**Weld tolerance** Applied to a welding symbol tail by placing the tolerance value and a note giving a reference to the weld feature where the tolerance is applied.

**White cast iron** Iron that is extremely hard, brittle, and has almost no ductility.

**Whitworth threads** Referred to as *parallel screw threads*; primarily used for replacement parts.

**Whole depth (spur gear)** Full height of the tooth. It is equal to the sum of the addendum and the dedendum.

**Whole systems** Process through which the interconnections between systems are actively considered, and solutions are sought that address multiple problems at the same time.

**Wide area network (WAN)** A network system that connects computers all over the world.

**Wireform** Three-dimensional form in which all edges and features show as lines, thus resembling a wire construction.

**Wire list (WL)** List of tabular data and instructions used to establish wiring connections.

**Wireframe model** Most basic CADD model; contains only information about object edges and vertices.

**Wireless diagram** Similar to highway diagram except that interconnecting lines are omitted. The interconnection of terminals is provided by coding.

**Wiring diagram** Type of schematic that shows all interconnections of a system's components; also referred to as a *point-to-point interconnecting wiring diagram*.

**Wood frame construction** Construction that uses dimensional lumber nailed together to form a supporting framework and covered with a variety of surfacing materials. Also referred to as *light-frame construction*.

**Wood screw** Screw designed to attach metal to wood or wood to wood.

**Wool seals** Used where economical cost, lubricant absorption, filtration, low friction, and a polishing action are required. *See also* Felt seals.

**Work features** In CADD, construction points, lines, and surfaces that create reference elements anywhere in space to help position and generate additional features.

**Working depth (spur gear)** Distance that a tooth occupies in the mating space. It is equal to two times the addendum.

**Working drawing** Complete set of detail drawings, subassemblies, assembly, parts list or bill of materials, and written specifications related to a product.

**Working drawing assembly** *See* Detail assembly.

**Worm gears** Gears used to transmit power between nonintersecting shafts. The worm is like a screw and has teeth similar to the teeth on a rack. The teeth on the worm gear are similar to the spur gear teeth but are curved to form the teeth on the worm.

## X

**Xerography** Dry photographic or photocopying process in which a negative image formed by a resinous powder on an electrically charged plate is electrically transferred to and fixed as positive on a paper or other copying surface.

## Z

**Zero declination** Places on Earth where a compass points exactly toward the true north or south pole.

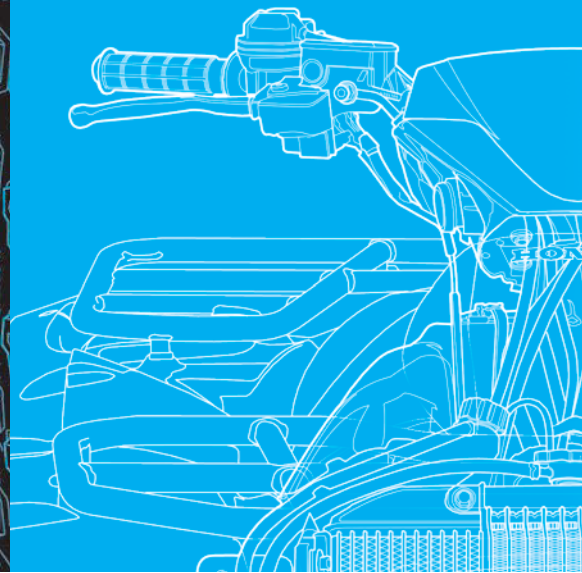
**Zip drive** Removable storage device that securely stores computer data magnetically. Zip drives and Zip disks are durable, portable, easy-to-use, and extremely efficient. One 250-MB Zip disk can store the same amount of data as 173 floppy disks. Zip disks are available in 100-MB, 250-MB, and 750-MB formats.

**Zoned system** HVAC system that allows for one or more heaters and one thermostat per room.

**Zoning** System of numbers along the top and bottom and letters along the left and right margins of a drawing; used to make reading and locating items easier.



# INDEX



Page numbers in *italics* indicate figures.

## A

- ABR. *See* Polyacrylic rubber (ABR)  
Abrasive saw, 144  
ABS. *See* Acrylonitrile-butadiene-styrene (ABS)  
AC (alternating current) circuits  
  elementary diagrams, 814  
ACC. *See* American Chemistry Council (ACC)  
Acetal, 127  
Acetate, 127  
Acme thread, 396, 404  
Acorn nuts, 417  
Acoustical liner (AL), 1044  
Acrylics, 127  
Acrylic-styrene-acrylonitrile (ASA), 127  
Acrylonitrile-butadiene-styrene (ABS), 127  
  for pipe, 877  
Active device, 832  
Actual local size, 320  
Actual mating size, 320–21  
Actual size, 320–21  
Actuator, 891  
Acute angle, 220  
Adaptive parts, 109  
ADDA. *See* American Design Drafting/Digital Design Association (ADDA)  
Addendum formula, 697, 698, 704, 706  
Addendums to contracts, 914, 979  
Additive process, 844–45  
Adhesion, 122  
Adjacent views, 266  
Advanced research, 1135–36  
Aeronautical drafter, 15  
AGMA. *See* American Gear Manufacturers Association (AGMA)  
Agonic line, 1075  
A hubs, 692  
AIA. *See* American Institute of Architects (AIA)  
AIA CAD Layer Guidelines, 1016  
Air-conditioning circuit and cycle diagram, 1017  
Air-duct calculators, 1044–45  
Air-duct sizing formulas, 1045, 1064  
Airflow analysis, 994  
Air-handling unit (AHU), 1044  
Air supply registers, 1016–17  
Air terminals, 1044  
Air-to-air heat exchangers, 1020  
AISC. *See* American Institute of Steel Construction (AISC)  
AISC/AWS standards  
  prequalified welded joints, 765  
AISI. *See* American Iron and Steel Institute (AISI)  
AISI/SAE steel numbering system, 123–24, 132  
AL. *See* Application list (AL)  
Alberta Energy Utility Board, 874  
Alberti Battista, Leon, 11  
Alcoa, 1021  
Algor® software, 116  
Alibre, Inc., 73  
Alibre Design, 73  
Alibre Personal Edition, 73  
Aligned dimensioning, 326  
  and piping drawings, 900  
Aligned sections, 446  
Alkyds, 128  
All around dimensioning symbol, 325  
All over dimensioning symbol, 325  
Allowance, 355. *See also* Tolerances  
  defined, 321  
  for metric threads, 404  
Alloy cast iron, 123  
Alloys  
  commonly used in manufacturing, 123, 124–25  
  section lines for, 202  
  selection of, 131–32  
  Unified Numbering System for, 125–26  
All-weather driveway surfaces, 1103  
Alternate view placement, 259  
Aluminum  
  basic features, 124–25  
  in green construction, 971  
  section lines for, 202  
  selection of, 131–32  
*Aluminum for Future Generations*, 126  
American Chemistry Council (ACC)  
  plastic resin identification codes, 129  
  plastics selection guidelines, 129–31  
American Design Drafting/Digital Design Association (ADDA), 28  
  chapters, 28  
  employment center, 29  
  history of, 28  
  professional certification, 28  
American Gear Manufacturers Association (AGMA), 692, 696  
American Institute of Architects (AIA), 94, 1016  
American Institute of Steel Construction (AISC), 765  
American Iron and Steel Institute (AISI), 123  
American National screw thread, 393  
American National Standards Institute (ANSI), 1144  
American National Standard taper pipe threads, 396–97, 403  
American National thread form, 395  
American Society for Quality (ASQ), 1134  
American Society of Mechanical Engineers (ASME) standards. *See* ASME standards  
American Water Works Association (AWWA), 877  
American Welding Society (AWS), 765  
  drafting standards, 30  
AMP. *See* Amplifier (AMP)  
Amplifier (AMP), 836, 838  
Analysis of EDA software tools, 850  
Analytic geometry, 11  
Analyzing working drawings, 620–27  
Anchor bolts, 942, 972, 975  
Anchors, wood to masonry, 947, 956  
Angle of projection block, 58, 59  
Angle of repose, 1091, 1110, 1111  
Angles  
  basic features, 220  
  bisecting, 228  
  dimensioning, 335  
  of oscillation in four-bar linkages, 681  
  structural steel, 963  
Angle valves, 888, 889  
Angular contact ball bearings, 709  
Angular dimension line, 324



- Angular dimensions, 329  
 Angularity tolerances, 511–12  
 Angular perspective. *See* Two-point perspective  
 Angular surfaces, dimensioning, 335  
 Angular units, on engineering drawings, 329  
 Animation(s), 84–86  
   e-learning, 86  
   engineering, 85–86  
   entertainment, 86  
   storyboarding, 86  
   techniques, 86  
 Annealing, 124  
 Annotations (electronic), 835  
 ANSI. *See* American National Standards Institute (ANSI)  
 ANSI/ASME standards  
   pipe sizes and wall thickness, 878–79  
   welding symbols, 748  
 ANSI/ISA standards  
   piping symbols, 907  
 ANSI standards  
   gear drawings, 693, 696  
 Ant backlash spring, 424  
 Apparent overlap, 553  
 Application block, 61  
 Application list (AL), 612  
 Applications  
   job, 26  
   patent, 31–32  
 ArchiCAD, 74  
 Architectural drafters, 15, 16  
 Architectural electrical symbols, 820, 821–22  
 Architectural lettering styles, 208–9, 209  
 Architect's scale, 49–50  
 Archive drawings, storage of, 64  
 Arc length symbol, 325  
 Arcs, 223  
   CADD commands for, 226  
   concentric, 227  
   dimensioning, 336–37  
   drawing, 233  
   isometric, 187, 570  
   showing in multiviews, 262–66  
   sketching, 179–80, 187  
 Argon (CADD software), 73  
 Arm drafting machine, 13, 45  
 ARRAY command, 401  
 Arrowheads, 324, 330  
   on dimension and leader lines, 324  
   rules for, 199–200, 200  
   in welding symbols, 750, 755, 757–59  
 Arrowless dimensioning, 381  
 Arrow side of welded joint, 755, 757  
 ASA. *See* Acrylic-styrene-acrylonitrile (ASA)  
 As-built drawings, 620  
 Ashlar-Vellum, 73  
 ASME codes and standards  
   piping and pipelines collection, 876  
   slip-on pipe flanges, 885  
 ASME drafting standards, 29  
 ASME/ISO standards  
   multiview drawings, 249  
 ASME standards, 319–20, 349, 362, 574  
   dimension symbols, 325  
   electrical and electronic drawing, 811, 842  
   engineering change documentation, 599, 614  
   fasteners and springs, 393  
   lettering, 207  
   line, 54–57  
   line conventions, 193–94, 194  
   pictorial drawings, 563  
   undimensioned drawings, 780, 792  
   unit, 47  
 Aspect ratio, 1044  
 ASQ. *See* American Society for Quality (ASQ)  
 Assemblies  
   constraints, 108  
   defined, 987  
   model creation, 108  
   parameter-driven, 109  
   welded, 749  
 Assembly drawings, 444, 597, 603–04  
   basic features, 603  
   CADD tools and options, 614  
   defined, 603  
   detail assembly, 605–06  
   erection assembly, 606, 609  
   gear and bearing, 715–16  
   general assembly, 605  
   layout assembly, 604–05, 606  
   and parts list, 611, 622  
   pictorial assembly, 607, 610  
   printed circuit, 844, 846  
   for screwdriver, 622, 623, 624  
   subassembly, 606–07  
   types of, 604–07  
 Assembly files, 106  
 Assembly models, 615  
 Associated Lists, 811  
 Association Connecting Electronics Industries (IPC), 842, 843  
 Associative dimension, 347–48  
 Assumed azimuth, 1074  
 ASTM standards, 123, 938, 967  
   manufacturing metals, 122  
   steel pipes, tubes, and fittings, 877  
 AT symbol, 943  
 Attribute, defined, 207  
 Attributes, with symbols in CADD, 901  
 AutoCAD, 71, 73, 97  
   assembly drawing tools, 614  
   detail drawing tools, 601  
   detailed thread representations with, 401  
   DIMLIN command, 345  
   drawing aids in, 268  
   enlargements in, 269  
   geometric tolerancing with, 548–52  
   MLEADER command, 406  
   REVLOUD command, 916, 985  
   schematic thread representations with, 400  
   XLINE command, 267  
 AutoCAD DesignCenter, 101  
 Autodesk, Inc., 73  
 Autodesk Algor Simulation, 73  
 Autodesk Ecotect, 993, 995  
 Autodesk Green Building Studio, 993, 994, 995  
 Autodesk Inventor, 73, 116, 117  
 Autodesk Inventor Fusion, 627  
 Autodesk Revit, 73  
 Autodesk Seek free Web service, 1061–63  
 Autodesk Vault, 73  
 Autodesk® Seek, 848, 917–18, 997  
 Automatic cutter compensation, 146  
 Automatic pencil, 41  
 Automotive design drafter, 15  
 Automotive industry  
   plastics selection, 129–31  
 Auxiliary sections, 448  
 Auxiliary views, 292  
   analysis and review, 300–01, 302  
   CADD applications, 304–06  
   curves plotting in, 297  
   descriptive geometry and, 302  
   dimensioning, 344–45  
   enlargements, 297  
   full view, 293  
   layout process, 292, 302–03  
   location on different sheets, 298  
   math applications, 307  
   partial view, 293, 295  
   professional perspective, 307  
   removed views, drawing, 297, 298  
   rotated, 298–99  
   secondary, 299–300, 301  
   visualization, 295–96  
 AWS. *See* American Welding Society (AWS)  
 AWWA. *See* American Water Works Association (AWWA)  
 Axes  
   creating for isometric sketches, 184  
   of pyramids, 222  
 Axial forces, defined, 930  
 Axis (thread), 394  
 Axis datums. *See* Datum axis  
 Axis geometric control, 495–96  
 Axis perpendicularity, 498  
 Axis straightness  
   effect of RFS on, 496  
   tolerances, 504  
 Axonometric projection, 563  
   types of, 566  
 Azimuth  
   measuring, 1073–74  
   traverses, 1076–77
- ## B
- Babbitt  
   section lines for, 202  
 Backflow valves, 890  
 Backsight, 1079  
 Back solving, 1143  
 Backward compatible, 1144  
 Ball bearings, 709  
 Balloons, 575, 610  
   identification numbers in, 607, 715  
   to identify engineering changes, 613  
   leaders styles for, 610  
   piping notes in, 909  
   with page identification, 612  
 Ball valves, 887, 888  
 Band saw, 144  
 Bars (steel), 963  
 Base circle, 684  
   diameter, 697, 699

- Base features in solid modeling, 107
  - Baseline, 1083
    - dimensioning, 332
  - Basic dimensions, 321, 479, 485
  - Basic Facts about Registering a Trademark*, 32
  - Basic size, 358
  - Basic solid models, 104
  - Bead chain, 736
  - Beams
    - compass, 42
    - defined, 928
  - Bearing (direction)
    - of electrical supply lines, 817
    - expressing, 1074, 1075
  - Bearings, 709
    - bore, 710
    - codes, 710
    - dimensions, 711
    - drawing, 710
    - with gear assemblies, 643–44, 715–16
    - lubrication requirements of, 713
    - major types, 709–10, 710–11
    - mountings, 715
    - numbering system, 711
    - oil grooving of, 713
    - pressures, 936
    - selection, 710
    - symbols for, 710
  - Beginning points, 1075, 1078
  - Begin vertical curve point, 1091
  - Bell and spigot connections, 880
  - Bell Crank, 680
  - Belt drive ratio, 734
  - Belt drives, 727
    - advantages of, 728
    - basic purpose, 728
    - common configurations, 728, 729
    - design, 730, 731
    - length calculation, 741
    - selecting, 730–34
    - types, 728–29, 730
  - Belt length, 741
  - Belts, 728
    - and belt drives, 728
    - defined, 728
    - flat belts, 729
    - positive drive belts, 729, 730
    - types, 728
    - V-belts, 728–29
  - Belt velocity, 734
  - Benches, 1110
  - Bench marking. *See* Existing product research
  - Bench marks (BM), 1078
    - finding distance and elevation from, 1079, 1080
    - symbol for, 1078
  - Bend allowance, 776, 782
    - calculating, 782–85
    - defined, 782
  - Bend angle, bend allowance and, 782
  - Bend, defined, 777
  - Bend diagrams (rebars), 943, 948
  - Bend facets, 786
  - Bending
    - corner to round, sheet metal, 786
    - metal, 138
    - precision sheet metal, 782–87
    - process, bend allowance and, 782
  - Bend instructions, 780
  - Bend radius, bend allowance and, 782
  - Bend relief, 786
  - Bend table, 780, 782
  - Bend tangent line, 780
  - Bend transition, 785
  - Bentley Systems, Inc., 73
  - BE pipe. *See* Beveled end (BE) pipe
  - Beveled end (BE) pipe, 879
  - Bevel gears, 694–95, 704–05
  - Bevel groove welds, 753–54
  - B hubs, 692
  - Bias, 832
  - Bidding requirements, defined, 929
  - Bilateral tolerances, 321, 351, 532, 534
  - Bill of materials. *See also* Parts list (PL)
    - guidelines for, 608, 612
    - on pipe spool sheets, 910
  - BIM. *See* Building information modeling (BIM)
  - Binocular Omni-Orientation Monitor (BOOM), 91
  - Binocular overlap, 91
  - Bisecting lines and angles, 228, 229
  - Bitmap images, 407
  - Black belts, 1134
  - Blacksmithing, 138
  - Blanking, 791
    - chemical, 145
  - Blind flanges, 885, 886
  - Blind holes, 147, 395, 411
  - BLOCK command, 766
  - Block diagram
    - electrical, 811
    - electronic, 827–28, 829
  - Blocks, 1084
    - of subdivisions, 1084
  - Block shading, 584
  - Block technique, 181–83, 182
  - Blow molding, 154–55
  - Blue-line prints. *See* Diazo prints
  - Blueprint, 13, 62
  - BM. *See* Bench marks (BM)
  - Board, 13
  - Body of thread, 394
  - Bolt circles, 196–97, 197
  - Bolted connections, specifying, 967
  - Bolts and nuts, 408, 409
  - Bond beams, 947, 950
  - Boolean operation, 104
  - BOOM. *See* Binocular Omni-Orientation Monitor (BOOM)
  - Border, 57
  - Bores
    - of bearings, 710
    - of gears, 692
  - Boring techniques, 148
  - Bosses, 149, 150
  - Bottoming taps, 395, 411
  - Bottom-up assembly, 108
  - Boundary
    - defined, 449
  - Bow compass, 42
  - Bow dividers, 43
  - Box, developing, 1046, 1047
  - Box beams, 955, 959
  - Box method, 584–85
    - of isometric construction, 568–69
    - sketching circles, 176–77
  - Brainstorming, 39
  - Brass, 125, 202
  - Braze welding, 747
  - Brazing, 746–47, 881
  - Brazolet, 884
  - BREAK, 453
  - Break corner, 151, 264
  - Breaking chain, 1079
  - Break lines, 332, 334, 336
    - in partial views, 257, 258
    - types, 203
  - Break symbol
    - for a cylindrical solid shape, 452
    - for a cylindrical tubular shape, 452
  - Bridges and culverts standards, 1103
  - Brinell hardness test, 124
  - Broken-out sections, 448, 603
  - BROKEN VIEW, 453
  - Bronze
    - for bearings, 709
    - composition of, 125
    - section lines for, 202
  - Building design, analyzing, 913, 995
  - Building information modeling (BIM), 992
  - Building life cycle, 987
  - Building sections. *See also* Sections
    - functions in structural drawings, 976, 978, 979
  - Burrs, 151, 350
  - Bus, 817
  - Bushings, 709, 885
  - Business management strategy, 1133
  - Bus layout drawing, 817–19
  - Butterfly valves, 888, 889
  - Buttress thread forms, 396
  - Butt-welded steel pipe, 877
  - Butt welding, 879
  - Butyl rubber, 128
  - Butyrate, 127
- C**
- CAB. *See* Cellulose-acetatebutyrate (CAB)
  - Cabinet oblique drawing, 576, 578
  - Cable assemblies
    - electrical drafting, 813, 814
  - Cable diagrams
    - electrical drafting, 813
  - Cable harness diagrams. *See* Cable assemblies
  - CAD. *See* Computer-aided design (CAD); Computer-aided drafting (CAD)
  - CAD/CAM integration, 87, 164
  - CAD/CAM systems, 64, 87
    - elements of, 164
  - CADD. *See* Computer-aided design and drafting (CADD)
  - CADD/CAM, dimensioning for, 381–82
  - Cadence Design Systems, Inc., 850
  - CAE. *See* Computer-aided engineering (CAE)
  - CAGE code, 58

- Calculation, bend allowance, 782–85  
 Calendering process, 155  
 Camber, in glu-lam beams, 953  
 Cam design, 691  
 Cam displacement diagrams, 684, 691, 692  
   CADD applications, 691  
   creating, 684–87  
   development of, 687  
   as guide to manufacturing, 687–88  
 Cam followers, 684  
 Cam manufacturing, 691  
   CADD applications, 691  
 Cam profiles, 687, 688, 691  
   CADD applications, 691  
 Cam roller followers, 684  
 Cams  
   basic design features, 682  
   creating profiles for, 687–88  
   displacement diagram creation,  
     684–87  
   importance of understanding, 717  
   sketching, 182  
   types of, 683  
 CAM system. *See* Computer-aided  
 manufacturing (CAM) system  
 Cantilever beams, 958  
 Capacitance, 835  
 Capacitor, 829, 835  
 Caps, pipe, 883, 885  
 Cap screws, 409, 410, 417  
 CAQC. *See* Computer-aided quality  
 control (CAQC)  
 Carat, 125  
 Carbon steel pipe, 877  
 Carburization, 124  
 Careers  
   engineering drawing, 14–25  
   ethics, 30–31  
   finding employment, 26–27, 37  
   in related areas, 118  
 Carpal tunnel syndrome, 112–13  
 Cartesian coordinate system, 11, 225  
 Cartographer, 15  
 Cartographic drafter, 15  
 Case hardening, 124  
 Casting drafters, 15  
 Casting drawing and design, 361,  
   363, 364, 366  
   draft, 362  
   fillets and rounds in casting, 362  
   shrinkage allowance, 362  
 Castings  
   major types, 135–37  
   simulating in solid models, 166  
   steel, 123  
   thermoset plastic, 157  
 Cast iron  
   for pipe, 877  
   section lines for, 202  
   types, 122–23  
 Catalogs, 622, 623  
 Catalog feature, 107, 108  
 Cathode, 830  
 CATIA, 73–74  
 Cavalier oblique projection, 576, 578  
 CAVE. *See* Cave Automatic Virtual  
 Environment (CAVE)  
 Cave Automatic Virtual Environment  
 (CAVE), 91, 92  
 CE. *See* Concurrent engineering (CE)  
 Cellulose, 127  
 Cellulose-acetatebutyrate (CAB)  
   for pipe, 877  
 Cementing pipe, 881  
 Center dashes, 324  
 Center distance  
   for belt drives, 728, 729  
   for chain drives, 728, 735, 737  
   spur gear formula, 697  
 Centerline method  
   sketching circles, 177, 177–78  
 Center line of bend (CLB), 780  
 Centerlines, 324  
   as connection lines in exploded  
     assemblies, 575  
   as extension line, 198, 324, 343  
   dimensioning, in wood frame  
     construction, 960  
   of isometric construction, 569–70  
   in piping drawings, 895  
   precedence in multiviews, 266, 318  
   rules for, 196–97  
   spacing and offset, 324  
 Center plane datums. *See* Datum  
 center plane  
 Centers, lathe, 140, 141  
 Central forced-air systems, 1016–17  
 Centrifugal casting, 136  
 Ceramics, 122  
 Certification, 25  
 Chain, 1079  
   classification and types, 734  
 Chain dimensioning, 331–32  
 Chain drives, 727, 734  
   advantages of, 728  
   classification and types, 734  
   design, 737  
   light-duty chain, 736  
   nonprecision chains, 736  
   precision chains, 734–36  
   roller chain drive selection, 737–41  
   sprockets, 734, 735  
 Chain lines, 203, 204  
 Chain pitch, 735  
 Chamfers, 150  
   dimensioning, 335  
   showing in multiviews, 262–63  
   thread, 394, 398, 411  
 Champions, 1133  
 Change Manager, 627–28  
 Change Manager Environment, 627  
 Change order (CO), 616–18, 619, 624, 1038  
 Chart drawings, 327  
 Checker, 59  
 Check valves, 890  
 Chemical blanking, 145  
 Chemical machining, 145, 147  
 Chemical milling, 145  
 Chilled cast iron, 122  
 Chip, 837  
 Chlorofluorocarbon (CFC)  
   refrigerants, 1022  
 Chloroprene rubber, 128–29  
 Chlorosulfonated polyethylene (CSM), 129  
 Chopped fiber spraying, 158, 159  
 Chordal addendum, 697, 698  
 Chordal thickness, 697, 698  
 Chromium steel, 123  
 C hubs, 692  
 Chucks, lathe, 140–41  
 CIM. *See* Computer-integrated  
 manufacturing (CIM)  
 Circles  
   basic properties, 222–23  
   CADD commands for, 226  
   concentric, 227  
   dimensioning, 321  
   drawing, 223, 226  
   finding distances between, 629  
   isometric, 186, 570  
   in perspective drawings, 582–83  
   prime, 688–89  
   showing in multiviews, 262–66  
   sketching, 176–79, 177, 178  
 Circle tangent, drawing, 223  
 Circle templates, 44  
 Circuit, 811. *See also* Electrical drafting  
 Circularity tolerance, 505–07  
 Circular pattern, 107–8  
 Circular pitch, 697, 703  
 Circular runout, 544, 545  
 Circulator, 1018  
 Circumference, 222  
 Circumscribed circle, 221  
 Circumscribed polygons, 230  
 Cire perdue technique, 137  
 Civil CADD technician, 14  
 Civil drafters, 15–16, 17, 1072  
 Civil drafting, 1072  
   CADD applications, 1113–17  
   contour lines, 1107–09  
   cut and fill, 1091, 1092  
   distance and elevation, 1078–82  
   grading plans, 1095–98, 1099, 1100,  
     1101, 1110–11, 1112  
   green technology application, 1117–19  
   math applications, 1120  
   plotting traverses, 1077–78  
   property descriptions, 1082–83  
   property lines, laying out, 1103–07  
   site design considerations, 1101–03  
   site plan basics, 1092–95, 1100  
   site plan layout, 1100–01  
   site profiles, 1109–10  
   starting, 1084–91, 1092  
   survey, 1073–77  
 Civil engineer' scales, 47–49  
 Civil engineering drafter, 14  
 Civil engineering drawings  
   contour lines, 1086  
   direction concepts, 1073–75  
   highway layout, 1087–92  
   property descriptions, 1082–83  
   starting, 1084–86  
   surveying basics, 1075–76  
 Civil piping, 869  
 Classes of threads, 394  
 Clay pipe, 878  
 CLB. *See* Center line of bend (CLB)  
 Cleaning manual drafting equipment, 41  
 Clearance fits, 355, 358

- Clearance in spur gears, 697
- Closed-loop robotic systems, 163
- Closed traverses, 1075–76, 1077
- Close running fits, 357
- Close sliding fits, 357
- Cluster gears, 694, 701  
drawing, 701, 702
- CNC. *See* Computer numerical control (CNC)
- CNC program, 87, 164. *See also* Computer numerical control (CNC) systems
- CO. *See* Change order (CO)
- Coatings, dimensioning with, 361
- Coaxial features, position tolerancing, 519–21, 522, 523
- Cobalt (CADD software), 73
- Cock valves, 887
- CoCreate, 75
- Coded section lines, 202, 443–44
- Codes  
plastic resin identification codes, 129  
welding, 765
- Coils, 423, 829, 835
- Cold air (CA), 1016–17
- Cold-rolled steel (CRS), 123
- Cold saws, 144, 145
- Collaborative engineering, 1152
- Collets, lathe, 140–41
- Collision detection testing, 1028
- Color-coding, 1029
- Color gamut, 91
- Columbium, 125
- Column reinforcing, 938
- Commercial construction, specifications for, 986–88
- Commercial drafter, 16
- Commercial electrical plans, 819–21, 823, 824
- Compass-bearing traverses, 1076, 1077, 1078
- Compasses, 42  
beam compass, 42  
bow compass, 42  
emulating with hand, 178
- Component terminal holes, 842–43
- Composite positional tolerancing, 517–19, 520, 521
- Composite profile tolerance, 543
- Composites, 122, 158  
manufacturing, 158, 159
- Compression length (springs), 423, 424
- Compression molding, 157, 158, 159
- Computer-aided design (CAD), 8, 10. *See also* Computer-aided design and drafting (CADD)  
defined, 70  
sustainable-design practices, 116–17
- Computer-aided design and drafting (CADD), 10, 13, 14  
3-D digitizers with, 915  
adding text, 210–11  
animation, 84–86  
assembly drawing tools, 614, 615–16, 622  
auxiliary views, 304–06  
basic techniques, 93–101  
cam and gear design tools, 692  
cam displacement diagrams, 691  
cam manufacturing, 691  
cam profiles, 691  
in CIM systems, 161, 162  
common geometric constructions, 224–25  
computer-aided engineering, 84  
computer-aided manufacturing, 87  
computer-integrated manufacturing, 88, 88  
computer numerical control, 87–88  
constraints, 69  
creating springs, 429  
defined, 70  
design vs. industrial design, 1139  
design formats, 75–79  
design planning, 112  
detail drawing tools, 601  
dimensioning with, 345–47  
drafters and, 14  
in drafting/designing of precision sheet metal, 783  
drawing accuracy with, 304  
drawing and editing, 93, 94  
drawing springs, 428  
drawings templates, 99, 100–101  
ergonomics, 112–14  
factors, 75–76  
fastener symbol libraries, 421–22  
fastener tools, 422  
file management, 101  
file-referencing tools, 97  
geometric tolerancing with, 547–52  
graphical user interface (GUI), 72  
hardware, 71  
interface, 72  
layers for HVAC drawings, 1043  
lift hook, 69, 70  
line-drawing techniques, 204–6  
line standards and layers, 93, 94, 95–96  
major applications in industry, 79–88  
manual drafting and, 40  
manufacturing materials applications, 133–34  
MCAD software, 72  
mechanism design features, 683  
vs. microfilm, 64  
multiview tools and options, 267–69, 275  
note placement, 350  
operator, 14  
parts libraries, 33–34  
peripheral equipment, 71  
pictorial drawings with, 585–87  
piping models, 914–15  
piping symbols, 900, 901–2, 901–7  
plotting considerations, 98, 99–100  
productivity with, 112–14  
product life cycle management, 73, 79  
program, 445  
property line layout tools, 1106  
prototyping, 80–84  
reusability of, 33–34  
reusing content, 96–97  
revision cloud tools, 916, 984, 985  
site plan tools, 1113–17  
sketching, 187–91  
skill standards, 30, 111–12  
software manufacturers, 73–75  
software products, 71, 72–75  
solid modeling techniques, 104–11  
sprockets, 735  
standards, 111–12  
structural drafting tools, 983  
surface modeling techniques, 102–3  
sustainable-design considerations, 115  
symbols, 96–97  
technical illustration, 88  
technician, 14  
terrain model, 1115  
thread notes, 406, 408  
thread representations, 407  
three-dimensional illustration  
capabilities, 588–89  
tolerancing with, 360–61  
two-dimensional drawings, 71, 76, 77  
virtual reality, 89–93  
web-based collaboration, 79–80  
welding drawings with, 766, 767  
workstation, 71, 72, 113
- Computer-aided design and drafting (CADD), software programs  
drawing screw heads with, 417  
for drawing screw thread representations, 398  
fastener tools, 422  
spring creation tools, 429
- Computer-aided drafting (CAD), 8, 10
- Computer-aided engineering (CAE), 84  
in CIM systems, 163  
electronics, 849
- Computer-aided manufacturing (CAM)  
system, 87, 163. *See also* CAD/CAM systems
- Computer-aided quality control (CAQC), 163
- Computer-integrated manufacturing (CIM), 88, 161, 162–64
- Computer numerical control (CNC)  
systems, 691, 796  
in CIM systems, 163  
machining considerations in, 146  
role in CAD/CAM systems, 87–88, 164
- Computers in engineering drawings, 10.  
*See also* Computer-aided design and drafting (CADD)
- Concentric arcs, 227
- Concentric circles, 223, 227
- Concentricity tolerances, 529–30, 531
- Concentric reducer, 881, 883
- Concept phase of phase gate design process, 1137–40  
design specification, 1140  
industrial design, 1137, 1139  
quality function deployment (QFD), 1139–40
- Concept review, 1140
- Concrete  
construction methods, 936–47, 948, 950, 951, 952  
section lines for, 202  
weight and cubic yard calculations, 998
- Concrete masonry unit, 945–47
- Concrete pipe, 878

- Concrete slabs  
 defined, 936  
 plan, 972, 975  
 specifying in drawings, 943, 972, 975
- Concurrent engineering (CE), 1134
- Conductor lines. *See* Conductor traces
- Conductor traces  
 printed circuits, 840, 841
- Conductor width and spacing, on printed circuits, 842
- Conduit layout and detail drawings,  
 819, 820
- Coned disk, 425
- Cone distance, 704, 705
- Cone pattern development, truncated, 1051
- Cones  
 dimensioning, 335–36  
 developing, 1050–51
- Confusing symbols, 832
- Congruency, of geometric shapes, 998
- Conical features  
 dimensioning, 335–36  
 profile of, 543
- Conical taps, 1037
- Connecting rod, 680
- Connecting traverses, 1075–76, 1077
- Connection lines, 575  
 in exploded assemblies, 575
- Connection methods, industrial piping,  
 879–81
- Connectors  
 in foundation plans, 972, 975  
 joist and beam, 956, 958  
 in structural design, 966–69
- Consider ease of recycling, 1152
- Constant force spring, 426
- Constant velocity motion, 685
- Constraints, 69, 105, 348  
 for geometric construction, 225  
 levels, 105, 106  
 to lines, 204–5, 205
- Construction documents, defined, 929
- Construction drafter, 14
- Construction drawings, 929
- Construction lines  
 with auxiliary views, 305–06  
 basic features, 195  
 to create multiview layouts, 273, 274  
 sketching circles with, 176–77  
 use in CADD, 267, 268
- Construction methods  
 concrete block, 945–47, 950, 951, 952  
 engineered wood products, 953, 955,  
 959, 960  
 importance of understanding, 936  
 laminated beam, 950, 953, 957,  
 958, 959  
 poured and precast concrete, 936–42,  
 947, 948, 952  
 steel structures, 960–966  
 timber frame, 947–48, 950, 953–960  
 wood frame systems overview, 947
- Construction specifications, 986
- Content, process *versus*, 118
- Continuation sheet title block, 59
- Continuity of welds, 762
- Continuous reinforcing, 158, 159
- Continuous stave wood pipe, 878
- Continuous-White layer, 94
- Contour flange, 787
- Contour interval, 1092
- Contour lines, 1086, 1093, 1107–09  
 drawing, 1086, 1107–09  
 topographic concepts, 1092
- Contours  
 defined in civil engineering, 1086  
 dimensioning, 337–38  
 showing in multiviews, 262–66
- Contract documents, defined, 929
- Contractor drawing, 1028
- Control charting, 165, 169
- Control joints, 976
- Controlled radius (CR), 337  
 defined, 322  
 dimensioning, 322, 325
- Control limits, 165–66
- Control points, 102  
 in closed traverses, 1075  
 survey, 1107
- Control valves, 891  
 body and damper symbols, 906
- Conventional breaks, 452–53
- Conventional machining  
 prototyping by, 84
- Conventional tolerancing, 476
- Coordinate method, 582, 584–85  
 of isometric construction, 568–69
- Coordinate systems, 1073, 1074
- Copes, 135
- Coplanar bends, 785
- Coplanar profile tolerance, 542
- Coplanar surface datums, 487–88
- Coplanar surfaces, 542
- Copper alloys, 125, 202
- Copper pipe, 877
- Copper tubing, 877
- Copyright, 31, 1141
- Cores, casting, 135–36
- Cork, section lines for, 202
- Corner relief, 787
- Corrosive fluids, protecting valves from, 889
- Cosine, 1079
- Cotangent, 1079
- Counterbores  
 dimensioning, 325, 339–40  
 drawing, 148, 149  
 specifying for bolted connections, 968
- Counterdrill, 148, 149  
 dimensioning, 340
- Countersink  
 dimensioning, 325, 340  
 drawing, 148, 149
- Coupler, 680
- Coupling circuitry, 832
- Couplings (pipe), 882, 885
- Coupolet, 884
- Courses, 1075, 1077–78
- Cover sheet, 1029
- CR. *See* Controlled radius (CR)
- Cradle-to-cradle design, 1021
- Cranks, 680
- Creativity in design, 1147–49  
 principles of, 1148–49
- Crest (threads), 394
- Crossed helical gears, 695
- Cross fittings, 881, 883, 885
- Cross-functional team approach, 1135
- Cross-reference zoning, 298, 456
- Crown backing, 704, 705
- CRS. *See* Cold-rolled steel (CRS)
- CSM. *See* Chlorosulfonated polyethylene (CSM)
- Cubes, 186
- Cubic feet per minute (CFM), effect on duct sizing, 1040
- Cul-de-sacs, 1104
- Cumulative trauma disorder, 112
- Curve data, 1087
- Curved line, 219
- Curve length, 1087
- Curves. *See also* Arcs; Irregular curves  
 in auxiliary views, 297  
 in civil drafting plan views, 1087–88  
 in civil drafting profile views, 1091  
 in perspective drawings, 582–83  
 in property lines, 1103–04  
 in surface modeling, 102
- Cushion sections, in V-belts, 729
- Customer focus, 1152
- Cut, 777
- Cut and fill drawing, 1091, 1092, 1110,  
 1112. *See also* Grading plans
- Cutsheet, 1029, 1031
- Cutting line, 1088
- Cutting metal, 138
- Cutting-plane line, 200, 200–201, 440–42,  
 1088  
 in highway profile drawings, 1088  
 precedence in multiviews, 266  
 structural drafting practices, 931, 932
- Cycles (cam), 684
- Cycloidal motion, 686
- Cylinder intersecting cone, 1058, 1060–61
- Cylinder pattern development, truncated,  
 1048–49
- Cylindrical break lines, 203
- Cylindrical elbows, 1050
- Cylindrical features  
 intersections in isometric drawings, 570  
 position tolerancing for, 513  
 showing in multiviews, 262, 265
- Cylindrical roller bearings, 710
- Cylindrical shapes, dimensioning of, 334
- Cylindricity tolerance, 507

## D

- Dardelet thread forms, 396, 397
- Dassault Systèmes, 73
- Data list (DL), 612
- Datum axis, 488–89
- Datum center plane, 490–92
- Datum dimensioning  
 best for CNC, 146
- Datum features, 477  
 coaxial, 489  
 defined, 478  
 simulators, 478–79, 499  
 symbols for, 478, 480, 488, 490
- Datum precedence, 499–501

- Datum reference frame (DRF), 479, 481, 482
  - Datums, 375
    - defined, 321, 477
    - selecting, 553
  - Datum targets, 483–87
    - locating, 485–87
    - symbols for, 483
  - Da Vinci, Leonardo, 10–11
  - DC (direct current) circuits
    - elementary diagrams, 814
  - DC biasing, 832
  - Dead ends, 1103
  - Decimal Inch Drawing Sheet Size and Format*, 811
  - Decimal inches, 327
  - Decimal points, 327–28
    - on drawings, 207
  - Decking, 960
  - Declination
    - magnetic, 1074
  - Dedendum, 697
  - Dedendum angle, 704
  - Default dimension styles, 348–49
  - Default text styles, 210
  - Defects
    - minimizing, 165
    - waste, 1132, 1133
  - Deferred tangency, 236
  - Deflection, 423
  - Deflection-angle traverses, 1076, 1077
  - Deformed steel bars, 936, 937
  - Degree of curve, 1087
  - Degrees of freedom, 481–82
  - Deliverables, 1150
  - Delta, 351, 1039
  - Delta angle, 1087, 1104
  - Delta note. *See also* Flag notes
    - pipe drawings, 915
    - in structural drafting, 984, 985
  - Deming, W. Edwards, 1133
  - Depth dimensioning symbols, 325
  - Depth of threads, 394
  - Derived components, 108
  - Descartes, René, 11
  - Descriptive geometry, 11, 267
    - auxiliary views and, 302
  - Design documentation, 1144
  - Design drafter, 14, 628
  - Design drawings, 930
  - Designer's tools, 377–78
  - Design for everything (DfX), 1152
  - Design plan, 112
  - Design sketches, 620
  - Design specification, 1140
  - Destructive testing of welds, 762–63
  - Detachable chain, 736
  - Detail assembly drawings, 605–06
  - Detail drafter, 18, 20
  - Detail drawings, 598, 620–22, 1037
    - CADD tools and options, 601
    - conduit, 819, 820
    - coordination with sections in structural drafting, 934, 936, 972
    - defined, 597
    - of DRIVER, 622
    - electrical grounding, 819
    - foundations, 972
    - of HANDLE, 621, 622
    - layout process in structural drafting, 990
    - manufacturing information, 599
    - monodetail drawing, 599
    - multidetail drawings, 599
    - pipng, 910, 911
    - roof framing, 972, 977
    - sheet layout, 599
    - springs, 426
    - steps in making, 599
    - threads, 400–03
  - Detailed representation of threads, 397
  - Detailed spring representation, 426
  - Detailer, 1028. *See also* Detail drafter
    - defined, 928
  - DETAIL VIEW command, 271
  - Detail views
    - in multiview drawings, 258–59
  - Development phase of phase gate design process, 1140–44
  - DfX. *See* Design for everything (DfX)
  - Dial indicator, 545
  - Diameter nominal (DN), 909
  - Diameters, 222
    - defined, 321
    - dimensioning symbols, 325
  - Diametral pitch, 342, 696, 698, 703
  - Diaphragm symbols, 906
  - Diaphragm valves, 889
  - Diazo prints, 62
  - Diazo reproduction, 62
  - Die, 786
  - Die casting, 137
  - Dies (thread), 152, 361, 395, 394
  - Differential relays, 817
  - Diffusers, 1016
  - Digital product definition datasets, 111
  - Digital prototyping, 81
  - Dimension
    - defined, 321
  - Dimensional accuracy points, 793, 794
  - Dimensional constraint line, 204–5, 205
  - Dimensional constraints, 348, 105
  - Dimensional lumber, defined, 947
  - Dimensional stability of drafting media, 50
  - Dimensioning, 315. *See also* Geometric tolerance
    - ASME standards, 319–20, 349, 362
    - associative dimension, 347–48
    - auxiliary views, 344–45
    - basics, 320
    - with CADD, 345–47
    - for CADD/CAM, 381–82
    - casting drawings, 361–62, 363, 364
    - characteristics and definitions, 320–23
    - CNC options, 146
    - combined casting and machining drawing, 363, 366
    - components, 324
    - constraints, 348
    - dimension origin, 344, 345
    - excluded from assembly drawings, 603
    - forging, design, and drawing, 363, 368–69
    - fundamental concepts, 323, 327–34
    - in general notes, 349–51
    - good practices, 334–38
  - ISO 9000 Quality Systems Standard, 378–79
  - in isometric drawings, 573–74
  - jig and fixture design, 378
  - location dimensions, 342–44
  - machined features, design and drafting of, 373
  - machined surfaces, 370–73
  - machining allowance, 362–63
  - machining drawing, 363, 365
  - maximum and minimum dimensions, 361
  - notes for machined features, 338–42
  - phantom lines, on machining allowance and draft angles, 363, 367
  - in piping drawings, 900, 908
  - plastic part manufacturing, drawings for, 369–70
  - platings and coatings, dimensions applied to, 361
  - rules for multiviews, 302–03, 315–19
  - site plan layout, 1104–06
  - style setting, 348–49
  - symbols, 325
  - threads, 404–05
  - tolerancing and, 351–61
  - tool design, 373–78
- Dimensioning and Tolerancing*, 47, 59
- Dimensioning and tolerancing block, 59–60
- Dimensioning fundamentals, 327
  - arrowheads, 330
  - baseline dimensioning, 332
  - chain dimensioning, 331–32
  - cylindrical shapes, dimensioning, 334
  - decimal points, 327–28
  - dimensioning units, 327
  - dimension lines and numerals, 330–31
  - dimension line spacing, 330
  - direct dimensioning, 332–34
  - fractions, 329–30
  - layout standards and specifications, 328
  - metric and inch units, 328–29
  - square features, dimensioning, 334
  - stagger adjacent dimensions, 334
  - symmetrical objects, dimensioning, 334
- Dimensioning systems, 326
  - aligned dimensioning, 326
  - chart drawings, 327
  - rectangular coordinate dimensioning without dimension lines, 326–27
  - tabular dimensioning, 327
  - unidirectional dimensioning, 326
- Dimensioning units, 327
- Dimension lines
  - AutoCAD features, 345
  - defined, 297, 324
  - and numerals, 330–31
  - rules for, 198
  - spacing of, 330
  - structural drafting practices, 930–31, 932
- Dimension numerals, 324, 330–31
- Dimension origin symbols, 325, 344, 345
- Dimension styles, 348–49
- Dimension text, 324
- Dimetric projection, 563, 574
- DIMLIN command, 345

Diode, 830  
 Direct-angle traverses, 1076  
 Direct dimensioning, 332–34  
 Directional relays, 817  
 Directional survey drafters, 16  
 Direct surface modeling, 103  
 Discontinuity of welds, 762–63  
 Displacement diagram, 684  
   CADD tools and options, 692  
   creating, 684–87  
   as guide to manufacturing, 687–88  
 Displacement of cams, 681, 683, 684  
 Display functions, 269  
 Distances, surveying, 1078–82  
 Distribution, electricity, 814  
 DIVIDE command, 1049, 1051  
 Dividers, 43  
   bow dividers, 43  
   proportional dividers, 43  
 DL. *See* Data list (DL)  
 DN. *See* Diameter nominal (DN)  
 Documents, defined, 929  
 DOE-2, energy modeling program, 993  
 Dot-to-dot method, 175, 175–76  
 Double bend, 785  
 Double helical gears, 694  
 Double-lap seams, 1046  
 Double lead worms, 705  
 Double-line drawing, 899, 900  
 Double pitch roller chain, 735  
 Double-row ball bearings, 709  
 Dovetails, 151  
 Dowel pins, drawing, 418  
 Downloading, on beams, 958  
 Down spouts, 976  
 Draft angles  
   in casting drawings, 362  
   in forging drawings, 363  
   phantom lines on, 363, 367  
 Drafter, 14. *See also* Drafting  
   CADD and, 14  
   defined, 14  
   industries working for, 14  
 Drafting. *See also* Engineering drawing  
   ADDA and, 28–29  
   CADD and, 10, 13, 14  
   careers in, 14–25  
   computer use overview, 10  
   defined, 8, 193  
   electrical. *See* Electrical drafting  
   electronic. *See* Electronic drafting  
   equipments, 13  
   fields, 14–25  
   finding employment, 26–27, 37  
   history, 10–14  
   manual. *See* Manual drafting  
   mechanical, 8  
   precision sheet metal, 776–808. *See also*  
     Precision sheet metal  
   salaries, 27–28  
   standards, 29–30  
   ties with manufacturing, 168  
 Drafting furniture, manual drafting, 41  
 Drafting geometry, 219  
 Drafting machine, 13, 45–46  
   arm, 13  
   arm drafting machine, 45

  track, 13  
   track drafting machine, 46  
 Drafting pencils, manual drafting, 41–42  
 Drafting technician, 14  
 Drafting templates, 101  
 Draftsperson, 14  
 Drags, 135  
 Drawing accuracy, 304  
 Drawing aids, 204–5  
 Drawing and editing, 618–19  
   with CADD, 93, 94  
 Drawing area, calculating, 316  
 Drawing content  
   extracting, 109  
   reusing, 96–97  
 Drawing dimensions, 361  
 Drawing lines, 204–6  
 Drawing planning process, 39–40  
   preparing a drawing, 40  
   problem-solving process, 39–40  
   research techniques, 39–40  
 Drawing revisions  
   revision clouds, 1038–39  
 Drawing scales, 46–47  
 Drawing sections, 451  
 Drawing sheets  
   piping, 910, 914  
   for structural drafting, 933, 934  
 DRF. *See* Datum reference frame (DRF)  
 Drill, 147  
 Drilled holes, 147  
 Drill fixtures, 375  
 Drilling drawings, 844, 845  
 Drilling machine, 140  
 Drill jigs, 375  
 DRIVER, 622  
   detail drawing of, 622  
 Drivers, in four-bar linkages, 680  
 Driveways, 1102–03, 1104, 1106  
 Drum cams, 690  
 Dry sand molding, 135  
 Dryseal American National Standard Taper  
   Pipe Thread, 413  
 Dryseal pipe thread, 413  
 Dual purpose, 1022  
 Ductalator, 1045  
 Ductility, 122  
 Duct sizing, 1039–40  
   effect of an acoustical liner on, 1044  
   effect of aspect ratio on, 1044  
   effect of velocity (FPM) on, 1040, 1044  
   effect of volume (CFM) on, 1040  
 Ductwork  
   defined, 1016  
 Dumb solid models, 104, 105  
 Durability of drafting media, 50  
 Dwell (cam), 682, 684  
 Dwg101–3Dim layer, 94  
 Dxf file, 1064  
 Dynamic load spring application, 425  
 Dynamics, 679  
 Dynamic sealing of bearings, 713

## E

Earth, section lines for, 202  
 Easements, 1088, 1102

E-business, 1152  
 Eccentric circles, 223  
 Eccentric reducer, 881, 883  
 ECM. *See* Electrochemical machining (ECM)  
 ECN. *See* Engineering change notice (ECN)  
 ECN number, 618–19  
 ECO. *See* Engineering change order (ECO);  
   Epichlorohydrin rubber (ECO)  
 Economic efficiency, 1132  
 Ecosystem, green technology application  
   in, 1117  
 ECR. *See* Engineering change request (ECR)  
 EDA. *See* Electronic design automation  
   (EDA)  
 Edge views, 296  
 Editing  
   with CADD, 93, 94  
   parametric models, 108–9  
 EDM. *See* Electrodischarge machining  
   (EDM)  
 Education, 22–23, 25  
 Elastomers, 127, 128–29  
 Elbolet, 881, 884  
 Elbows, 881, 883, 885  
 E-learning animations, 86  
 Electrical circuits, 811  
 Electrical conduit, 870  
 Electrical drafters, 16, 18  
 Electrical drafting. *See also* Drafting  
   overview, 810  
   residential and commercial, 819–21,  
     822–24, 824  
   standards, 810–11, 842  
   substation design, 814–19, 820  
   types of diagrams, 811–13, 814  
 Electrical relays, 817  
 Electric-cable diagrammer, 16  
 Electricity  
   distribution, 814  
   generation, 814. *See also* Wind power,  
     electricity generation from  
   transmission, 814  
 Electric windings, 202  
 Electrochemical machining (ECM), 145  
 Electrodischarge machining (EDM), 145,  
   1079, 1080  
 Electrolysis, 844  
 Electron beam (EB) machining, 145  
 Electronic computer-aided design  
   (ECAD). *See* Electronic design  
   automation (EDA)  
 Electronic design automation (EDA), 850  
 Electronic drafters, 17, 19  
 Electronic drafting. *See also* Drafting  
   block diagrams, 827–28, 829  
   operational amplifiers and integrated  
     circuit schematics, 836–38, 839, 840  
   overview, 810, 827  
   pictorial drawings, 846, 847  
   printed circuits, 838, 840–46  
   schematic diagram, 828–36  
   standards, 810–11, 842  
 Electronic plots, 98  
 Electronics, 827  
 Electronics industry  
   plastics selection, 130, 131  
 Electronic theodolites, 1081

- Elementary diagrams, 814
    - AC (alternating current) circuits, 814
    - DC (direct current) circuits, 814
  - Elevation reading, 1081
  - Elevations
    - contour lines, 1086, 1107–08
    - pipng, 909–10
    - in structural drawings, 976, 979, 980, 981
    - surveying, 1078–82
  - Elevation symbol, 972, 977
  - Elimination, waste, 1133
  - Ellipses, 44
    - in auxiliary views, 297
    - drawing techniques, 236–37, 237
    - for inclined circles in multiviews, 263
    - isometric, 571
    - sketching, 180, 186
  - Ellipse templates, 44–45
    - isometric, 44–45
  - Elliptical arc, drawing, 237
  - Employment
    - ADDA Employment Center, 29
    - drafting careers, 14–25
    - ethics in, 30–31
    - seeking, 26–27, 37
  - End milling cutters, 142, 143
  - End-result specifications, 986
  - End thrust, 694
  - End types (springs), 423
  - End vertical curve point, 1091
  - Engineering wood products, 953, 955, 959, 960
  - Engineering animations, 85–86
  - Engineering calculations, structural
    - drawings from, 928–29
  - Engineering change notice (ECN), 616–18, 619, 626
  - Engineering change order (ECO), 616–18, 619, 624, 1038, 1150
  - Engineering change request (ECR), 615–16, 618, 624–27, 1150
  - Engineering copiers. *See* Photocopy printers
  - Engineering design process
    - after full production, 1147
    - concept phase, 1137–40
    - creativity and innovation, 1147–49
    - deliverables, 1150
    - development phase, 1140–44
    - execution phase, 1144–47
    - impact of change on, 1149–50
    - implementing, 1134–37
    - overview, 1131
    - responds to changes in engineering, 1150–51
    - systems approach, 1130–31
  - Engineering drafter, 19, 20
  - Engineering drafting, 8–10, 19
  - Engineering drawing, 8–10, 319
    - careers, 14–25
    - computers in, 10
    - drawing planning process, 39–40
    - early practices, 10
    - education, 22–23, 25
    - history, 10–13
    - pioneers, 10–12
    - qualification, 25
    - wrench, 2–7, 3–7
  - Engineering maps, 1084, 1085
  - Engineering sketches. *See also* Sketching
    - analyzing, 620
    - creating detail drawings from, 218, 292, 299–300, 315–19
    - isometric drawings from, 562
    - structural drawings from, 928–29
  - Enlargements
    - for auxiliary views, 297
    - CADD tools and options, 269, 271
    - in multiview drawings, 258–59
  - Entertainment, 86
  - Environmentally friendly product, 1151
  - EPDM. *See* Ethylene propylene diene monomer (EPDM)
  - Epichlorohydrin rubber (ECO), 129
  - EPM. *See* Ethylene propylene rubber (EPM)
  - Equal bilateral tolerance, 351
  - Equilateral triangles, 220, 221
  - Erasability of drafting media, 50
  - Erasers, 42
  - Erection assembly drawings, 606, 609
  - Ergonomics, 112–14
  - Etched process, 844–45
  - Ethyl cellulose, 127
  - Ethylene propylene diene monomer (EPDM), 129
  - Ethylene propylene rubber (EPM), 129
  - Evapotranspiration, 1118
  - Exaggerated vertical scales, 1089
  - Excavation, 936
  - Execution phase of phase gate design
    - process, 1144–47
  - Executive leadership, 1133
  - Exercises, 113–14
  - Existing product research, 1136–37, 1143
  - Expander flanges, 886
  - Explicit modeling, 105
  - Exploded assembly, 575
  - Exploded pictorial drawing, 575, 576, 577
  - Exploded technical illustrations, 607
  - Exporting, 98
  - Extension lines, 908
    - point established by, 324, 338
    - rules for, 198
  - Extension springs, 423
  - Exterior elevations, 976, 979, 980, 981
  - External arcs, 234
  - External features, maximum material
    - condition, 321, 322
  - External reference system, 97
  - External spur gears, 694
  - External threads
    - basic features, 152–53
    - components of, 394
    - designing, 411–12
    - dimensioning, 404
  - Extreme attitude variation, 513, 514
  - Extreme form variation, 356, 494
  - Extreme positional variation, 513
  - Extrusion, 124, 154, 155
- F**
- Fabrication drawings, 966
  - Fabrication methods, 969
  - Fabrics
    - section lines for, 202
  - Face angle, 704
  - Face cams, 683
  - Face gear, 695
  - Faces
    - defined, 188
    - of gears, 692
    - of polyhedrons, 222
  - Face width, 704
  - Facilities drafter. *See* Commercial drafter
  - Facings of pipe flanges, 886–87
  - Failure mode effect analysis (FMEA), 1142
  - Fakespace, Inc., 91
  - Fall (cam), 684
  - Farad, 835
  - Fasteners, 392. *See also* Threads
    - cap screws, 417
    - detailed threads, drawing, 400–03
    - dowel pins, drawing, 418
    - hexagon head, 416–17
    - keys, keyways, and keyseats, 419–20
    - lag screws, 414
    - nuts, drawing, 417–18
    - positional tolerancing of, 523–26, 527
    - retaining rings, 419
    - rivets, 420, 421
    - screw heads, 416–17
    - screw thread fasteners, 393–94
    - screw threads, measuring, 406
    - self-clinching, 415–16
    - self-tapping screws, 414
    - symbol libraries for, 421
    - taper pins, 418–19
    - thread-cutting tools, 395
    - thread design guidelines, 410–14
    - threaded fasteners, 408–09
    - thread forms, 395–97
    - thread inserts, 414, 415
    - thread notes, 403–05
    - thread representations, 397–400
    - washers, drawing, 418
    - wood screws, 414
  - Fault condition, 819
  - FDM. *See* Fused deposition modeling (FDM)
  - FEA. *See* Finite element analysis (FEA)
  - FEA software. *See* Finite element analysis (FEA) software
  - Feature-based solid modeling, 104
  - Feature control frames, 487, 502, 503, 504, 517, 531
  - Feature of size, 321
  - Feature pattern, 107
  - Feature-relating control, 517
  - Features
    - defined, 321
  - Feed lines, 812
  - Feet per minute (FPM), effect on duct
    - sizing, 1040, 1044
  - Felts, section lines for, 202
  - Felt seals, 715
  - FEM. *See* Finite element method (FEM)
  - Ferrous metals, 122, 126
  - FFF. *See* Free-form fabrication (FFF)
  - Fiberglass-reinforced pipe (FRP), 877
  - Fibers
    - section lines for, 202



- Field notes (survey), 1082, 1107, 1108  
 Field welds, 759  
 Field work, importance to pipe drafting, 919  
 Filament winding, 158, 159  
 File management, 101  
 File naming, 101  
 File-referencing tools, 97  
 File templates, 29  
 Filled-in arrowheads, 330  
 Filled plastics, 706  
 Fillets  
   basic features, 151  
   in casting drawings, 362  
   in forging dies, 363  
   pictorial drawing techniques, 584  
   showing in multiviews, 264, 265  
   tangent arc applications, 223  
 FILLET tool, 627  
 Fillet welds, 745, 751–52  
 FIM. *See* Full indicator movement (FIM)  
 Find number, 612  
 Finished drawings, creating from rough sketches, 174  
 Finite element analysis (FEA), 163, 1143  
 Finite element analysis (FEA) software, 69, 74  
 Finite element method (FEM), 69  
 Firebreaks, 1103  
 Fire clay for pipe, 878  
 Firefighting water supply, 1103  
 Fire ratings, 953  
 Fire safety zone, 1103  
 First-angle projection, 251, 254  
 Fits  
   for bearings, 711  
   selection of, 356  
   threads, 394  
   types, 356–59  
 Fittings (pipe), 881–85, 900  
 Fitting-to-fitting, 909  
 Fixed fastener, 524–26, 527  
 Fixed-value device, 830  
 Fixtures  
   application examples, 374  
   assembly drawing, 374  
   basic features, 160, 161  
   components, 375  
   drawings, 162  
   types, 375–76  
 Flag notes, 351, 1039  
 Flame cutting, 747  
 Flanged connections, 879, 880  
 Flanges (piping), 885–87  
 Flanges, 787–88  
   of steel beams, 963, 964  
 Flange welds, 754, 757  
 Flare-bevel groove weld, 753–54, 760  
 Flare-V groove welds, 753, 760  
 Flaring connection, 881  
 Flask handler design, 717  
 Flasks, casting, 135  
 Flat belts, 729  
 Flat-faced follower, 684  
 Flatness tolerance, 505  
 Flat patterns  
   defined, 777, 1016  
   sheet metal part, 777, 778  
 Flat spring, 424  
 Flat wire compression springs, 424–25  
 Floating fastener, 418, 524, 526  
 Floor plan  
   laying out, 988–89  
   lighting layout, 821, 822  
   in structural drawings, 972, 973  
 Flow valve symbols, 907  
 Fluoroelastomers (FPM), 129  
 Fluoroplastics, 127  
 Flush contour welds, 754, 755  
 Flush hubs, 692  
 Fly-through, 89–90  
 FMEA. *See* Failure mode effect analysis (FMEA)  
 Foam molding, 157, 158  
 Foil, 776  
 Folded-down form, 832  
 Folding, prints, 62  
 Fold lines  
   defined, 250  
   to establish auxiliary views, 294, 296  
 Followers  
   cam, 682, 687  
   in four-bar linkages, 680  
 Fonts, defined, 207  
 Footings  
   purpose of, 936  
   specifying in drawings, 944, 972, 975  
 Force fits, 357  
 Foreshortening  
   in dimetric projections, 574  
   in isometric drawings, 590  
   in multiview drawings, 249, 250, 267  
   need for auxiliary views with, 293  
 Foresight, 1079  
 Forged pipe, 877  
 Forge welding, 138  
 Forging, 3  
   drafters, 15  
   drawing and design for, 363, 368–69  
   machining compared, 139  
   major types, 137–38  
   simulating in solid models, 166  
 Formaldehyde, 1020  
 Formal plate cam drawing, 688, 689  
 Forms concrete, 936  
 Form tolerances, 504–07  
 Formulas, gear, 698, 704, 706  
 Foundation, building, 936  
 Foundation plans and details  
   laying out, 989  
   in structural drawings, 972, 975  
 Four-Bar Linkage, 680, 681  
 Four-center method, 186  
 Fourth generation reproduction, 63  
 FPM. *See* Fluoroelastomers (FPM)  
 Fractions, 329–30  
   on drawings, 208  
 Free-form fabrication (FFF), 156, 157  
 Free length of springs, 424  
 Free running fits, 357  
 Free state variation, 506  
 French curves, 45  
 Front elevations, 979  
 Front views  
   criteria for selecting, 254–55, 255  
   visualization from, 294  
 FRP. *See* Fiberglass-reinforced pipe (FRP)  
 Full indicator movement (FIM), 544  
 Full sections, 444  
   assembly drawings in, 603, 604, 606  
   in isometric drawings, 571  
 Functional elements, defined, 987  
 Functioning prototype, 1140–41  
 Fused deposition modeling (FDM), 81, 160
- ## G
- Gaps between dimension lines and numbers, 324  
 Garter spring, 426  
 Gasket drawings, 256, 257  
 Gaskets, 713, 880  
 Gas metal arc welding, 747, 748  
 Gas tungsten arc welding, 747, 748  
 Gates  
   in design process, 1137, 1140, 1144, 1147  
   electronic, 837  
 Gate valves, 887, 888  
 Gauge, 776  
 G-codes, 88, 146, 164  
 GD&T. *See* Geometric dimensioning and tolerancing (GD&T)  
 Gear and bearing assemblies, 715–16  
 Gear drives  
   advantages over belt and chain drives, 728  
 Gear ratios, 702  
 Gears, 691, 692  
   basic features, 692  
   data, 702  
   designing and drawing, 696–702, 705–06  
   drawing, 698  
   importance of understanding, 717  
   plastic, 706–08  
   spline options, 692–93  
   spline tolerances, 696  
   structures, 692  
   types of, 693–94  
 Gear trains, 691, 702–03  
 General arrangement (GA) drawings. *See* Pipe drawings  
 General assembly drawings, 605  
 General notes, 349–51  
   defined, 320  
   surface finish in, 371  
 General oblique drawing, 576, 578  
*General Tolerances*, 29  
 General tolerances, 353  
 Generation, electricity, 814  
   from wind power, 825–27. *See also* Wind power, electricity generation from  
 Generations of drawing copies, 63  
*Generic Standard on Printed Circuit Board Design*, 842  
 Geological drafters, 17  
 Geometric characteristic symbols, 501–02  
 Geometric constraint line, 204, 205  
 Geometric constraints, 105, 225, 348

- Geometric constructions  
 basic shapes, 220–24  
 with CADD, 224–25  
 common types, 224–30  
 defined, 219  
 ellipses, 236–37, 237  
 polygon, 230–33  
 similarity and congruency, 998  
 tangents, 233–36
- Geometric continuity, 102
- Geometric dimensioning and tolerancing (GD&T), 476  
 additional symbols, 502, 503  
 axis control, 495–96  
 CADD applications, 547–52  
 combined controls, 544  
 datum precedence and material condition, 499–501  
 datums, 477–92  
 feature control frame symbol, 502  
 form tolerances, 504–07  
 geometric characteristic symbols, 501–02  
 least material condition (LMC), 498–99  
 material condition and material boundary symbols, 492–93  
 math applications, 555  
 maximum material condition (MMC), 496–98  
 orientation tolerances. *See* Orientation tolerances  
 perfect form boundary, 494, 495  
 profile tolerance, 532–44  
 regardless of feature size (RFS), 494, 495  
 regardless of material boundary (RMB), 494, 499  
 runout, 544–46  
 size, limits of, 494  
 specifying independency, 546, 547  
 surface control, 494  
 symbols, 477
- Geometric tolerance  
 definition of, 321
- Geometric Tolerance dialog box (AutoCAD), 548, 550, 551, 552
- Geometry  
 analytic, 11  
 descriptive, 11
- GEOPACK Civil Engineering Suite, 73
- Geophysical drafters, 18
- Giant crossbow, 11
- Girts, 962
- GL. *See* Ground line (GL)
- Glass, section lines for, 202
- Glass box principle, 248, 250–52, 294
- Glass pipe, 878
- Glider, 10, 11
- Globe valves, 888
- Gluing pipe, 881
- Glulam beams (GLB), 953, 957, 959
- Gold, 125
- Google Earth, 74, 189, 190, 191
- Google Inc., 74
- Google SketchUp, 74, 188, 189
- Gothic lettering, 207
- Grades, 1103
- Grade slope, 1091
- Grading plans, 1091, 1095–98, 1099, 1100, 1101, 1110–11, 1112
- Grain of material, bend allowance and, 782
- Graphical Symbols for Diagrams*, 810
- Graphical user interface (GUI)  
 CADD, 72
- Graphic Symbols for Electrical and Electronic Diagrams*, 810–11, 814
- GRAPHISOFT, 74
- Graphite (CADD software), 73
- Graticule, 1073
- Gravel under slab, 936
- Gray cast iron, 122
- Great circles, 1073, 1074
- Green belts, 1134
- Green buildings  
 aluminum in, 971  
 defined, 969  
 guidelines, 970  
 steel in, 970–71
- Green Building Rating System™, 969
- Green construction, defined, 970
- GreenFormat, 988
- Green sand, 135
- Green technology, 1021
- Green technology application, 1117–19, 115–17
- Grid, 841–42
- Grid azimuth, 1074, 1075
- Grid lines, 792–93
- Grid survey method, 1107, 1108
- Grid system (printed circuit), 841–42
- Grinding machine, 140
- Grooves  
 in bearings, 713  
 dimensioning, 342  
 indicating in welding symbols, 758–59, 760
- Groove welds, 753–54
- Ground grid, 819
- Grounding layout and detail drawings, 819
- Ground line (GL), 578
- Ground plane, 843
- Grouped objects, dimensioning, 347
- Grout joint, 946
- Guide for the Preparation of Patent Drawings*, 32
- Gunter's chain, 1079
- Gutters, 976
- ## H
- Half coupling, 882, 885
- Half sections, 444–45, 571
- Hammerhead turnarounds, 1104
- Hand-compass method of sketching circles, 178
- Hand drafting. *See* Manual drafting
- Hand forging, 138
- HANDLE, detail drawing of, 621, 622
- Hangers  
 joist and beam, 956, 959  
 piping, 894, 895, 896, 897, 898
- Haptic interface, 91–92
- Hard copy, 62, 98
- Hardening of steel, 124
- Hard metric conversion, 908
- Hardness testing, 124
- Hardware  
 CADD workstation, 71
- HATCH command, 449
- Head Chainman, 1079
- Headers, defined, 955
- Head mounted display (HMD), 90–91
- Healthy soil, 1119
- Heating, ventilating, and air-conditioning (HVAC) systems  
 Heat pump system, 1019
- Heat treating, 124
- Heavy bearings, 710
- Heavy drive fits, 357
- Heavy timber construction, 948, 950, 955
- Height of the instrument (HI), 1079
- Heliarc®, 747
- Helical gears, 694
- Helical springs, 423
- Helical torsion springs, 424
- Helix direction (springs), 424
- Hem, 1046
- Hems, sheet metal, 788
- Henry, 835
- Herringbone gear, 694
- Hexagon head fasteners, 416–17
- Hexagons  
 dimensioning, 336
- Hex head bolt, 417
- Hex nuts, 416, 418
- HI. *See* Height of the instrument (HI)
- Hidden features, 255, 316, 335
- Hidden lines, 317. *See also* Sections overview, 195, 196  
 excluded from assembly drawings, 603  
 excluded from auxiliary views, 295  
 precedence in multiviews, 266, 318  
 rules for, 195–96, 196
- High-carbon steel, 123
- High-performance HVAC and green technology, 1021–22  
 innovation, 1022  
 viability, 1022
- High-pressure side of the system, 1044
- High-speed steel, 123
- Highway diagrams. *See* Highway wiring diagrams
- Highway layout, 1087–91, 1092
- Highways, 812
- Highway wiring diagrams  
 electrical drafting, 812
- History-based modeling, 627
- History-based solid models, 104, 105. *See also* Parametric solid modeling
- HL. *See* Horizon line (HL)
- HMD. *See* Head mounted display (HMD)
- Holding fixtures. *See* Drill fixtures
- Holes  
 location dimensioning, 343  
 position tolerancing, 515, 517  
 printed circuit board, 842–43, 844  
 showing in multiviews, 263  
 size dimensioning, 338–39, 343  
 for standard bolts, 968  
 threaded, 410–11
- Hole sizes, 338

- Hole table, 780, 782  
Honing, 140  
Horizon line (HL), 578  
Horizontal band saw, 144  
Horizontal lines, sketching, 175–76  
Horizontal mills, 142  
Horsepower (HP), 737  
Hot gas welding, 881  
Hot-rolled steel (HRS), 123  
Hot-water system, 1018  
Housing fits, 711–12  
HP. *See* Horsepower (HP)  
HRS. *See* Hot-rolled steel (HRS)  
Hubs of gear, 692  
  types of, 692  
HVAC CADD software, 1041–42  
HVAC contract drawing, 1026  
  from an engineering sketch, 1022, 1025–28  
  an HVAC contract drawing, 1028–29  
HVAC drawings, 1022  
HVAC models, 1044  
HVAC plans, 1041–42  
HVAC symbols, 1022, 1023–24  
HVAC symbols specifications  
  detail drawings, 1037  
  pictorial drawings, 1038  
  schedules, 1037–38  
  section drawings, 1037  
  written specifications, 1032, 1036–37  
HVAC systems and components, 1016  
  drafters, 18, 20  
Hydraulic flask handler design, 717  
Hydrochlorofluorocarbons (HCFCs), 1022  
Hydroforming, 139  
Hydronic radiant heating, 1019  
Hydrozoning, 1119  
Hypoid gears, 695  
Hypotenuse, 919  
  defined, 221
- I**
- IAI. *See* International Aluminum Institute (IAI)  
IC. *See* Integrated circuit (IC)  
ID. *See* Industrial design (ID); Inside diameter (ID)  
*Identification Coding and Application of Hook-up and Lead Wire*, 836  
Identification numbers  
  electronics, 836  
  in working drawings, 607–08, 612, 715  
Idlers, 730  
IEC. *See* International Electrotechnical Commission (IEC) standards  
IEEE. *See* Institute of Electrical and Electronics Engineers (IEEE)  
IIE. *See* Institute of Industrial Engineers (IIE)  
I-Joists, 955, 959, 960  
IK. *See* Inverse kinematics (IK)  
Illustrated parts breakdowns. *See* Exploded technical illustrations  
IML. *See* Inside mold line (IML)  
IMSI/Design, LLC, 74  
Inch dimensions, 329  
Inch tolerances  
  specified and unspecified, 352–53  
Inch units  
  on engineering drawings, 329  
Incident solar radiation analysis, 995, 996  
Inclined lettering, 208  
Inclined planes  
  circles and arcs on, 263–64  
Included angles (thread), 394  
Included angles, 1104  
In-control processes, 165  
Index contours, 1086, 1109  
Indoor combustion, 1019–20  
Inductance, 829, 835  
Inductor, 829, 835  
Industrial design (ID), 589  
  in concept phase, 1137, 1139  
  defined, 1137  
  vs. modified CADD, 1139  
Industrial process-pipe drafter, 18–19, 20  
Industrial property, 1141  
Information Age of Technology, 1131  
Information grouping, 608  
Infrastructure, defined, 73  
In-house, 1029  
  operations, 1141  
Injection molding, 139, 153–54  
Injuries, preventing, 112–13  
Inline followers, 684  
Innovation in design, 1147–49  
Inorganic materials in manufacturing, 122  
INOVATE, 74  
In-place creation, 108  
Input  
  defined, 71  
Inscribed circle, 221  
Inscribed polygons, 230  
Inside diameter (ID), 877  
Inside mold line (IML), 780, 782  
Inspection fixtures, 376  
Inspection processes, 165–66  
Institute of Electrical and Electronics Engineers (IEEE), 810–11, 814, 831  
Institute of Industrial Engineers (IIE), 1134  
Instrument/function symbols, 905  
Insulation, section lines for, 202  
Integrated circuit (IC), 837  
Integrated product development (IPD), 1134  
Intellectual properties, 30–31, 1141–42  
Intelligence in parametric modeling, 105, 563  
Intelligent worlds, 93  
Interchangeability, 12  
Interface  
  CADD, 72  
  defined, 188  
Interference fits, 355–56, 358  
Intergraph, 74  
Interior elevations, 979, 981  
Intermediate contours, 1086, 1109  
Intermittent fillet weld, 761  
Internal features, maximum material condition, 321, 322  
Internal integrated circuit schematics, 837  
Internal spur gears, 694  
Internal threads  
  basic features, 153  
  components of, 394  
  dimensioning, 404  
International Aluminum Institute (IAI), 126  
International Electrotechnical Commission (IEC) standards  
  electrical and electronic drafting, 810, 842  
International Organization for Standardization, 378  
International System of Units, 327  
Internet, 64  
  project collaboration via, 79–80  
  value-added applications of, 1152  
Intersecting cylinders, 1056–57  
Intersecting lines, 219, 220  
Intersecting prisms, 1056  
Intersecting shafting gears, 694  
Intersection  
  in isometric drawings, 570–71  
  in section, 447  
Intervals, contour, 1092  
Intranet, 64  
Invention disclosure, 1141  
Inventor Open Fusion DWG command, 627  
Inventory waste, 1132, 1133  
Inverse kinematics (IK), 85–86  
Inverted tooth silent chain, 736  
Invert elevation of sewer lines, 1091  
Inverter, 826  
Investment casting, 137  
Involute curve, 696, 698  
Involute spline, 693  
Ionomers, 127  
IPC. *See* Association Connecting Electronics Industries (IPC)  
IPD. *See* Integrated product development (IPD)  
IRONCAD, 74  
Irregular curves  
  for manual drafting, 45  
  parallel, 227  
  in perspective drawings, 583  
Irregular shapes, sketching, 182, 183  
Irrigation system, 1119  
ISO 2768 general tolerances, 354  
ISO 9000, 378–79  
ISO drafting Standards, 29–30  
IsoDraw, 572  
Isogonic lines, 1074–75, 1076  
Isometric arcs, 570  
  sketching, 187  
Isometric circles, 570  
Isometric construction techniques, 568–74  
  box method, 568–69  
  centerline method, 569–70  
  coordinate method, 568–69  
  intersections, 570–71  
  isometric dimensioning, 573–74  
  isometric sections, 571, 572  
  isometric spheres, 572, 573  
  isometric threads, 572  
Isometric dimensioning, 573–74  
Isometric drawings, 563, 567  
  isometric projections versus, 566–68  
  pictorial, 607

piping, 874, 875, 910, 912–13  
 types of, 568  
 Isometric ellipses, 571  
   sketching, 186  
   templates, 44–45  
 Isometric lines, 185, 186, 567  
 Isometric planes, 567  
 Isometric projections, 567–68  
   and isometric drawings, 566–68  
 Isometric scale, 567–68  
 Isometric sections, 571, 572  
 Isometric sketches  
   calculating pipe lengths from, 868–69  
   from crude sketches, 562  
   techniques for creating, 184–87  
 Isometric spheres, 572, 573  
 Isometric threads, 572  
 Isosceles triangle, 220–21, 221  
 ISO thread specifications, 396  
 Item, 612  
 Item numbers. *See* Identification numbers

## J

J groove welds, 754  
 Jig and fixture design, 160, 161, 162, 373,  
   378. *See also* Tool design  
 Jigs, 160, 161  
 JIT. *See* Just-in-time (JIT)  
 Jobs  
   engineering drawing careers, 14–25  
   in related areas, 118  
   seeking, 26–27, 37  
   workplace ethics, 30–31  
 Joints  
   in concrete slabs, 976  
   industrial piping, 880, 881  
   welded types, 762  
 Joists, floor, 939  
 Journal bearings, 709  
 Justification, for text objects, 211  
 Just-in-time (JIT), 1132

## K

Kaizen event, 1131  
 KBE. *See* Knowledge-based engineering  
   (KBE)  
 Kerfs, 143, 151  
 Keyboards, 113  
 KeyCreator, 74  
 Keys, 152, 419–20, 692  
 Keyseats  
   defined, 152  
   dimensioning, 341  
   drawing, 152, 419–20  
 Keyways  
   defined, 152  
   dimensioning, 341  
   drawing, 152, 419–20  
   of gears, 692–93  
 K factor, 783, 785  
 Killed steel, 124  
 Kilohms, 835  
 Kinematics, 679

Kinetics, 679  
 Knife-edged follower, 684  
 Knowledge-based engineering  
   (KBE), 1134  
 Knurling, 153, 341–42  
 Knurl pitch, 342  
 Kubotek Corporation, 74

## L

Labels  
   electronic schematics, 832–33, 835,  
   835, 836  
 Labyrinth seals, 714  
 Lag screws, 414  
 Laminated beam construction, 950, 953,  
   957, 958, 959  
 Laminated veneer lumber, 955, 959, 960  
 Lancing, 789  
 Land parcels, 1082  
 Land relief pictorials, 1093  
 Landscape drafters, 19, 21  
 Lands of printed circuits, 840, 841  
 Lap-joint flange, 885, 886  
 Lapping, 140  
 Lap-welded steel pipe, 877  
 Large-scale integration (LSI), 838, 839  
 Lasers  
   cutting and machining with,  
   145, 147, 341  
 Laterals (piping), 881, 885  
 Latex, 127  
 Lathes, 140–41, 395  
 Latitude, 1073  
 Latrolet, 881, 884  
 Lay, 371  
 Layers (CADD), 205–6  
   in composites, 158, 159  
   construction lines on, 195  
   drawing techniques, 93, 94, 95–96  
   used in industrial applications, 93, 94  
 Layout assembly drawings, 604–05, 606  
 Layouts  
   for auxiliary views, 302–03  
   CADD steps, 304  
   for detail drawings, 601, 604  
   details and sections in structural  
   drafting, 936  
   electronic schematics, 832, 834  
   for multiviews, 267, 272–74, 275  
   for pictorial drawings, 584–85  
   piping drawings, 916, 917  
   precision sheet metal, 777–82  
   printed circuit, 843  
   site plans, 1100–01, 1102,  
   1104–06, 1107  
   for structural drafting, 988–89  
 Layout space, 98, 272–73  
 LCA. *See* Life Cycle Assessment  
   (LCA) tools  
 Lead  
   section lines for, 202  
 LEADER command, 766  
 Leader line  
   for balloons, 607  
   rules for, 199

  use in dimensioning, 318, 324, 335  
   in welding symbols, 749, 750, 755,  
   757–59  
 Leadership in Energy and Environmental  
   Design (LEED™) program,  
   969–71, 1019  
   green building guidelines, 970  
 Lead grades, 41, 42  
 Leads, 394, 706  
 Lead time, 3  
 Leaf, 776  
 Lean manufacturing, 377, 1132–33  
   goals of, 1132–33  
 Lean production. *See* Lean manufacturing  
 Least material boundary (LMB), 493  
 Least material condition (LMC),  
   355, 493  
   defined, 321  
   geometric tolerancing with, 498–99  
   positional tolerance at, 515  
 Leather  
   section lines for, 202  
 LEED™. *See* Leadership in Energy and  
   Environmental Design (LEED™)  
   program  
 Left-hand threads, 394  
 Legibility, of lettering, 209  
 Lettering  
   defined, 207  
   in detail views, 258–59  
   on engineering drawings, 207  
   format, 54, 57  
   legibility, 209  
   numbers, 207–8  
   standards and practices, 328  
   structural drafting practices, 933  
   style overview, 208–9  
   styles in CADD, 210–11  
 Leveling, 1079, 1082  
 Levels, 680, 1079  
 Library feature, 107, 108  
 Life Cycle Assessment (LCA) tools, 115  
 Life cycle engineering, 1134  
 Life safety system, 1022  
 Lift check valves, 890  
 Lift hook, 69, 70  
 Light bearings, 710  
 Light drive fits, 357  
 Light-duty chain, 736  
 Lighting fixture schedule, 821, 823  
 Limits  
   dimensioning, 351, 352, 353  
   of feature size, 494, 553  
 Limits of dimension  
   defined, 322  
 Line  
   ASME standards, 54–57  
 Linear bearings, 709. *See also* Bearings  
 Linear patterns, 108  
 Line balloons, 909  
 LINE command, 205  
 Line contrast, 193  
 Line-contrast shading, 583  
*Line Conventions and Lettering*, 54, 194  
 Line drawing format, 205–6  
 Line element perpendicularity, 511  
 Line of intersection, 1055–56

- Lines  
 ASME standards, 193–94, 194  
 CADD drawing techniques, 204–6  
 characteristics of, 219–20  
 constraints, 204–5, 205  
 dividing equally, 229  
 drawing, 223, 225–26  
 format for drawing, 205–6  
 parallel, 227  
 perpendicular, 227–28  
 precedence in multiviews, 266  
 profile of, 532–36, 537, 538, 539  
 sketching, 175–76, 180–81  
 structural drafting practices, 930–932  
 types, 194–204  
 used in dimensioning, 198, 324
- Line shading, 583–84
- Line standards  
 CADD drawing techniques, 93, 94, 95–96
- Line tangent  
 drawing, 223
- Line weights  
 ASME standards, 193–94, 194  
 defined, 195
- Linkages, 679  
 defined, 679  
 importance of understanding, 717  
 symbols for, 679–80  
 types of, 680
- Liquid crystal polymers, 127
- List numbers, 1028
- List of materials. *See* Bill of materials; Parts list (PL)
- Lithium-ion battery, 1136
- LMB. *See* Least material boundary (LMB)
- LMC. *See* Least material condition (LMC)
- Load capacities (road), 1103
- Loading extension of springs, 424
- Lobed ring seals, 714, 715
- Local meridians, 1073
- Local notes, 320
- Locating tolerance zone, 543
- Locational fits, 357  
 clearance fits, 357  
 interference fits, 357  
 transition fits, 357
- Location dimensions, 320, 342–44  
 holes, locating, 343  
 multiple features, of nearly same size, 344  
 polar coordinate dimensioning, 343  
 polar orientation, locating multiple tabs in, 344  
 rectangular coordinate dimensioning, 343  
 repetitive features, dimensioning, 343–44  
 for structural steel, 966
- Location tolerances, 512–28
- Logic circuits, 837
- Logic diagrams, 838
- Long-axis isometric drawing, 568
- Longitude, 1073
- Loop traverses, 1075–76, 1077
- Loose running fits, 357
- Lost-wax casting, 137
- Lot and block system, 1082, 1083–84
- Lots, 1082, 1084, 1096
- Lowercase lettering, 208
- Lower control limits, 166, 351
- Low-pressure side of the system, 1044
- LSI. *See* Large-scale integration (LSI)
- Lubrication, 713–14  
 bend allowance and, 782
- Lugs, 149, 150
- Lumber, standard callouts, 955, 960
- ## M
- Machined features, 338  
 counterbore, dimensioning, 339–40  
 countersink/counterdrill, 340  
 design and drafting of, 373  
 holes, dimensioning, 338–39  
 keyseats and keyways, dimensioning, 341  
 knurls, dimensioning, 341–42  
 multiple features, dimensioning, 340, 341  
 necks and grooves, dimensioning, 342  
 slots, dimensioning, 340–41  
 spotface, dimensioning, 340
- Machined surfaces, 370–73
- Machine forging, 138, 139
- Machinery's Handbook*, 132, 776  
 fastener head information, 417  
 gear data, 692  
 purchase part information, 614  
 steel data, 124  
 thread forms, 404, 413
- Machinery's Handbook*, *ASME Handbook*, 782
- Machines  
 drafting. *See* Drafting machine  
 screws, 408, 409  
 tangency design and drafting application for, 234, 235  
 tools versus, 374–75
- Machining allowance, 362–63  
 phantom lines on, 363, 367
- Machining drawing, 363, 365, 366
- Machining fixtures, 375
- Machining processes  
 basic features created by, 147–53  
 chemical and electronic methods, 145, 147  
 cost considerations in design, 168  
 defined, 140  
 simulating in solid models, 167  
 tool design for, 160, 161, 162, 373–78  
 tools for, 140–45
- Magma Design Automation, 850
- Magnesium, section lines for, 202
- Magnetic azimuth, 1074–75
- Magnetic declination, 1074–75, 1076
- Magnetic poles, 1074–75
- MAJOR DIA, 523
- Major diameter (thread), 394
- Major subdivisions, 1095, 1097, 1101
- Male-and-female facings, 887
- Malleable cast iron, 123
- Malleable iron  
 section lines for, 202
- Management science. *See* Operations management
- Manganese, 123
- Manual drafting, 8  
 CADD and, 40  
 compasses, 42  
 dividers, 43
- erasers, 42  
 irregular curves, 45  
 machines, 45–46  
 media, 50–53  
 overview, 40  
 pencils, 41–42  
 pens, 42  
 reproduction methods, 43  
 scales for, 46–50. *See also* Scales  
 sheet sizes for, 53–54, 55–56  
 templates, 44–45  
 triangles, 43–44
- Manual of Steel Construction*, 963
- Manufacturing. *See also* Machining processes  
 CAD/CAM systems, 164  
 CADD applications, 133–34  
 castings, 135–37  
 cells, 163  
 computer-integrated, 161, 162–64  
 drafter's role in providing specifications for, 596  
 forgings, 137–38, 139  
 hydroforming, 139  
 metallurgy, 126  
 metals commonly used in, 122–26  
 plastic fabrication processes, 153–59  
 powder metallurgy, 139–40  
 process simulating in models, 166–67  
 product development sequence, 122  
 rapid prototyping, 160  
 stamping, 138–39  
 statistical process control, 165–66  
 tool design, 160, 161, 162, 373–78
- Marble  
 section lines for, 202
- Margin drawing number block, 61
- Marine drafter, 19
- Marketing, 1135
- Markups, 891
- Master black belts, 1134
- MasterFormat, 987
- MasterFormat 2004 Edition: Numbers and Titles*, 1036–37
- MasterFormat™: Master List of Numbers and Titles for the Construction Industry*, 1036
- Master patterns, 841
- Material boundary symbols, 492, 493
- Material condition, 492–93  
 datum precedence and, 499–501  
 location tolerances and, 515
- Material Condition dialog box (AutoCAD), 549
- Material list number, 1029
- Materials. *See also* Manufacturing  
 metallurgy, 126  
 metals, 122–26  
 plastics and polymers, 126–29  
 selection, 131–32  
 simulating in solid models, 166–67
- Materials science, 126
- Math applications  
 belt and chain drives, 741  
 distance between tangent circles, 629  
 length of a connecting rod, 718  
 for projected areas, 307  
 rounding numbers, 555

- MathCAD, 75
- Maximum dimensions, 361
- Maximum material boundary (MMB), 493
- Maximum material condition (MMC), 355, 493, 494
- defined, 322
  - geometric tolerancing with, 496–98
  - of internal and external features, 321, 322
  - positional tolerance at, 513
  - zero positional tolerance at, 529
- MCAD software. *See* Mechanical computer-aided design (MCAD) software
- M-codes, 88, 164
- Measurement lines, 180–81, 181
- Mechanical computer-aided design (MCAD) models, 627
- Mechanical computer-aided design (MCAD) software, 72
- Mechanical drafter, 19, 22
- Mechanical drawing/drafting, 8, 20, 22, 25.
- See also* Engineering drawing
- Mechanical engineer, 1016
- Mechanical engineer's scale, 50, 52
- Mechanical joint connections, 880, 881
- Mechanical/optical principles (MOD), 1079, 1080
- Mechanical spring, 421
- Mechanical systems, 1016
- Mechanics, 679
- Mechanisms, 679
- CADD applications, 683
  - in daily lives, 679
- Media for manual drafting, 50–53
- Media for undimensioned drawings, 793
- Medium bearings, 710
- Medium-carbon steel, 123
- Medium drive fits, 357
- Medium running fits, 357
- Megahelion™ drive, 116
- Melamine formaldehyde, 128
- Melt through, 759–60
- Mentor Graphics, Inc., 850
- MEP Modeler, 74
- Meridians, 1073, 1083
- Metal buildings, 961–62
- Metal injection molding (MIM), 139
- Metallurgy, 126
- Metals
- castings, 135–37
  - commonly used in manufacturing, 122–26
  - forgings, 137–38
  - section lines for, 202
  - stamping, 138–39
  - Unified Numbering System for, 125–26
- Metes and bounds system, 1082, 1083
- Method specifications, defined, 986
- Methyl pentenes, 127
- Metric dimensions
- in piping drawings, 908–9
- Metric Drawing Sheet Size and Format*, 811
- Metric fits, 358
- Metrics, 1140
- in piping, 909
- Metric scale, 47, 48
- Metric symbols/names
- rules for writing, 908–9
- Metric threads, 404
- forms, 396
- Metric tolerances
- specified and unspecified, 353–54
- Metric units
- on engineering drawings, 329
  - expressing on a piping drawing, 908
- Metric welded wire reinforcement, 938
- Metric welding symbol, 758
- Microfilm, 62–64
- alignment arrows, 61
  - vs. CADD, 64
- Micro-Station PowerDraft, 73
- MicroStation software, 73
- Mild steel, 123
- MIL-HDBK/MIL-STD. *See* Military defense handbook/standard (MIL-HDBK/MIL-STD)
- Military (MIL) standards, on line
- thicknesses, 194
- Military defense handbook/standard (MIL-HDBK/MIL-STD), 836
- Military identification systems, 836
- Millimeter dimensions, 329
- Millimeters, 327
- Milling
- chemical, 145
  - dimensioning slots for, 340–41
  - machine, 142–43
- Milwaukee Electric Tool Corporation, 1135
- MIM. *See* Metal injection molding (MIM)
- Minimum and maximum slopes, 1101
- Minimum dimensions, 361
- Minimum required annular ring, 843
- Minor diameter (thread), 394
- Minor subdivisions, 1095, 1096–97
- Minus draft method, 370
- Minutes, in surveying, 1073
- MIRROR command, 401
- Mirrored features, 108
- Mistake-proofing, 377
- Mitered elbow, 881, 884
- Miter gears, 694
- Miter joint, 787–88
- Mitre lines, 251
- defined, 183
- MLEADER command, 406
- MMB. *See* Maximum material boundary (MMB)
- MMC. *See* Maximum material condition (MMC)
- MOD. *See* Mechanical/optical principles (MOD)
- Model, sheet metal part, 779–80, 781, 789–90
- Model dimensions, 360–61
- Models, piping, 910, 914, 914–15
- Model sections, 450–51
- Model sketches, 187–88
- Model Space (AutoCAD), 601
- Model space, 98
- Model text, 212
- Modified constant velocity motion, 685, 686
- Modifiers, 492
- Modular construction, 835
- Moisture, 1019–20
- Mold, 361
- drafters, 15
- Molded lip packings, 714
- Molded plastic gears, 707
- accuracy of, 708
  - advantages, 707
  - disadvantages, 708
- Molded ring seals, 714
- Molybdenum, 123
- Moment, defined, 930
- Moment of inertia, defined, 930
- Monge Gaspard, Frenchman, 11
- Monitor ergonomics, 113
- Monodetail drawing, 599
- advantages, 599
  - CADD tools and options, 601
  - example, 598
- Mortar joints, 946, 951
- Motion blur, 91
- Motion waste, 1132, 1133
- Motorola, 1133
- Mountings for bearings, 715
- Mount St. Helens, 1086
- Movable datum target symbol, 490, 491
- MOVE command, 401
- Multiaxis milling machinings, 143
- Multiconductor systems, 813
- Multidetail drawings, 599
- Multifunctional robotics, 163
- Multilayer boards, 842
- Multilayer sandwich boards, 842
- Multiple bends, sheet metal, 785
- Multiple features, 344, 486, 515–19
- dimensioning, 340, 341
  - of same size, 344
- Multiple-strand chains, 734–35
- Multiview drawings, 11
- defined, 250
  - sheet metal part, 777–78
- Multiviews. *See also* Auxiliary views
- CADD tools and options, 267–71
  - creating from engineering sketches, 292, 299–300, 315–19
  - elements of, 250–52
  - first-angle projection basics, 254
  - layout process, 267, 272–74, 275
  - line precedence, 266
  - projecting contours, circles, and arcs, 262–66
  - sketching, 183, 183–84
  - third-angle projection basics, 252–53, 254
  - view selection for, 254–62
- Mylar®, 52
- ## N
- Nailed connections, 968
- NAND gate, 837
- National Pipe Taper Fuel (NPTF), 413
- National Standard taper pipe threads (NPT), 413, 909
- Natural rubber, 128
- Naturescaping, 1118
- NCS. *See* United States National CAD Standard (NCS)
- NC system. *See* Numerical control (NC) system
- Necks, 152
- dimensioning, 342

Needle roller bearings, 710  
 Needle valves, 888–89  
 Neoprene, 128–29  
 Nesting blanks, 791–92  
 Nests, 1064  
 Net cross-sectional dimensions (lumber), 957  
 Net inside area (NIA), 1044  
 Neutral axis, 782  
 Neutral zone, 782  
 Nipolet, 884  
 Nitrate, 127  
 Nitrile rubber, 129  
 Nodular cast iron, 123  
 Nominal pipe size (NPS), 397, 877, 878  
 Nominal sizes  
   defined, 322  
   lumber, 955  
 Nonassociative dimension, 348  
 Nondestructive testing of welds, 763, 764  
 Nondirectional relays, 817  
 Nonferrous metals, 122, 124–26  
 Nonintersecting shafting gears, 695  
 Nonisometric lines, 185, 185–86, 567  
 Nonparallel holes, 521, 523  
 Nonprecision chains, 736  
   detachable chain, 736  
   pintle and welded steel chains, 736  
 Nonprovisional patent applications, 31–32  
 Nonservo systems, 163  
 Non-uniform rational basis spline  
   (NURBS), 102  
 Normalizing, 124  
 Notes  
   as dimensions, 320  
   in piping drawings, 900, 908, 909  
   surface finish in, 371  
   with threads, 403  
 Not-to-scale dimension, 619  
 NPS. *See* Nominal pipe size (NPS)  
 NPT. *See* National Standard taper pipe  
   threads (NPT)  
 NPTF. *See* National Pipe Taper Fuel (NPTF)  
 NREL. *See* United States Department of  
   Energy National Renewable Energy  
   Laboratory (NREL)  
 Numbered symbols, 1037–38  
 Number of teeth, 698, 706  
 Numerical control (NC) system, 87. *See also*  
   Computer numerical control (CNC)  
   system  
 NURBS. *See* Non-uniform rational basis  
   spline (NURBS)  
 Nuts, 408, 409  
   drawing, 417–18  
   self-clinching, 415  
   types of, 409  
 NX, 75  
 Nylon, 127

## O

Object lines, 195  
   precedence in multiviews, 266, 318  
   structural drafting practices, 930–31  
 Object-Red layer, 94  
 Oblique drawing, 563, 576, 578  
 Oblique prism, 222  
 Oblique surface, 299, 300, 301  
 Observation platform design, 998  
 Obtuse angle, 220  
*Occupational Outlook Handbook*, 14, 22  
 Occupational overuse syndrome, 112  
 Occupations  
   engineering drawing careers, 14–25  
   finding employment, 26–27, 37  
   in related areas, 118  
   workplace ethics, 30–31  
 OD. *See* Outside diameter (OD)  
 OEE. *See* Overall equipment  
   effectiveness (OEE)  
 Offset cam follower, 688, 689  
 Offset cone, developing, 1051–52  
 Offset sections, 445–46  
 Offset sidebar roller chain, 736  
 Ogee, 2  
 Ogee curves, 235–36, 236  
 Ohms, 835  
 Oil and gas drafter, 19  
 Oil grooving of bearings, 713  
 Oil viscosities, 713  
 OML. *See* Outside mold line (OML)  
 One-line diagram, 814  
 One-pipe hot-water system, 1018  
 One-point perspective, 578–79, 580  
 One sigma process, 1133  
 One-view drawings, 256–57  
 On-off valves, 887, 888  
 OP AMP. *See* Operational amplifier (OP AMP)  
 Open arrowheads, 330  
 Open-loop robotic systems, 163  
 Open traverses, 1075, 1076  
 Operational amplifier (OP AMP), 836–37  
 Operations management, 1135  
 Optical theodolites, 1081  
 Orientation tolerances, 507  
   angularity, 511–12  
   concentricity tolerances, 529–30, 531  
   location, 512–28  
   parallelism, 507–09  
   perpendicularity, 509–11  
   symmetry tolerance, 530–31, 532  
   virtual condition, 513, 528–29, 530, 531  
 Orifice flanges, 886  
 Orifice plate, 886  
 O-ring seal, 714  
 Orthographic projections  
   defined, 249  
   sketching. *See* Multiviews sketching  
 Oscillation angles in four-bar linkages, 681  
 Other side of welded joint, 755, 757  
 Outline section line, 201, 201–2  
 Outlining projects, 219  
 Out-of-control processes, 165, 166, 169  
 Output  
   defined, 71  
 Outside diameter (OD), 710  
   bearings, 710–11  
   in gear structure, 692  
   pipe, 877  
   spur gear formula, 698  
 Outside mold line (OML), 782  
 Overall equipment effectiveness (OEE), 1133  
 Overflow drains, 976

Overlapping tolerance controls, 553  
 Overlay system, 205–6  
 Overlubrication of bearings, 713  
 Overprocessing waste, 1132, 1133  
 Overproduction waste, 1132, 1133  
 Overtakes, 1037  
 Oxyacetylene welding, 746  
 Oxyfuel welding, 746  
 Oxygen gas welding, 746–47  
 Ozalid dry prints. *See* Diazo prints

## P

P&ID. *See* Process and instrumentation  
   diagram (P&ID)  
 Packaging industry  
   plastics selection, 130  
 Packings, 713–14  
 Pads  
   drawing, 150  
   of printed circuits, 840, 841  
 Page identification  
   balloons with, 612  
 Page numbering systems, 933–35  
 Panel connections, concrete  
   construction, 940, 941  
 Panel elevations, 979, 982  
 Panelized roof systems, 947, 954, 955  
 Panel plan, 979, 982  
 Paper space, 98  
 Parallel bar, 13, 43  
 Parallelism tolerances, 507–09  
 Parallel lines, 219, 220, 227  
 Parallelograms, 221  
 Parallel perspective. *See* One-point  
   perspective  
 Parallels (geographic), 1073  
 Parallel shafting gears, 694  
 Parameter-driven assemblies, 109  
 Parameters  
   defined, 105  
   editing, 108–9  
 Parametric solid modeling, 563  
   assembly drawing tools with, 615  
   assembly modeling, 108  
   auxiliary views from, 306  
   creating 2-D drawings from, 270  
   dimensioning and tolerancing, 360  
   editing, 108–9  
   extracting drawing content, 109  
   overview, 104  
   part model elements, 107–8  
   simulating materials and processes in,  
     166–67  
   in structural drafting, 983  
   welding process options, 767  
   work environments, 105–7  
 Parametric Technology Corporation, 74–75  
 Parcels, 1082, 1084  
 Part files, 106  
 Partial auxiliary view, 293  
 Partial datum surface, 487  
 Partial views  
   in multiview drawings, 257, 258  
 Parting lines, 362  
 Parting plane, 362

- Part models  
elements, 107–8
- Parts, precision sheet metal, 777
- Parts libraries, 33–34
- Parts list (PL), 612. *See also* Bill of materials  
assembly drawing and, 622  
CADD tools, 615  
guidelines for, 622  
keying to working drawings, 605, 715–16  
with printed circuit board drawings,  
844, 846  
and working drawings, 597, 608–12
- Passive VR, 90
- Patches, 102
- Patent drafters, 19
- Patent research, 1141
- Patents, 31–32  
applying for, 31–32
- Pattern development, 1045  
defined, 1016  
of a truncated pyramid, 1052
- Pattern-locating control, 517
- PC. *See* Point of curve (PC)
- PCB. *See* Printed circuit board (PCB)
- PDCA. *See* Plan-do-check-act (PDCA) cycle
- PDM. *See* Product data management (PDM)
- Pedestal footings, 972, 975
- PEEK. *See* Polyetheretherketone (PEEK)
- Pencils, 41–42  
for sketching, 175
- Penetration of welds, 759, 760
- Penny classifications (nails), 968
- Pens, 42
- Percentage calculations, 768
- Perfect form boundary, 494, 495
- Periods (cam), 684
- Peripheral equipment  
CADD workstation, 71
- Permanent casting, 137
- Perpendicular bisector, 228
- Perpendicularity tolerances, 509–11
- Perpendicular lines, 219, 220, 227–28
- Perspective drawing, 565, 578, 579  
types of, 578
- Petroglyphs, 10
- PF. *See* Powder forging (PF)
- PFD. *See* Process flow diagram (PFD)
- Phantom lines, 203, 335, 363, 368, 374  
for contours in multiview drawings,  
264, 265  
drawing a detailed coil spring  
representation using, 427  
for drawing sheet metal part, 778  
on machining allowance and draft angles,  
363, 367
- Phase gate design process, 1137–47  
concept phase, 1137–40  
development phase, 1140–44  
execution phase, 1144–47
- Phenolics, 128
- Philadelphia rod, 1079
- Photocopy printers, 62
- Photodrafting, 846
- Photogrammetrists, 20
- PI. *See* Point of intersection (PI)
- Pickoff jig, 376
- Pickoff number, 1029
- Pictograms, 10
- Pictorial assembly drawings, 607, 610
- Pictorial drawings, 562, 563, 565, 566, 1038  
CADD applications, 585–87  
for catalogs, 622, 623  
circles and curves, 582–83  
from crude sketches, 562  
defined, 250  
dimetric projection, 574  
electrical drafting, 811  
electronics, 846, 847  
exploded, 575, 576, 577  
isometric, 566–68  
isometric construction techniques,  
568–74  
land relief, 1093  
layout for 584–85  
long-axis isometric drawing, 568  
oblique methods, 576, 578  
one-point perspective, 578–79, 580  
overview, 563  
perspective, 578, 579  
regular isometric drawing, 568  
reverse isometric drawing, 568  
shading techniques, 583  
solid models in, 563, 565  
in structural drafting, 991  
technical illustration, 565, 566  
three-dimensional illustration  
capabilities, 588–89  
three-dimensional visualization tools,  
563, 565  
three-point perspective, 580–82  
trimetric projection, 574–75  
two-point perspective, 580  
uses of, 566
- Picture plane (PP), 578
- PID. *See* Punch ID (PID)
- Piece numbers, 1028
- Pilaster, 947, 952, 953
- Pilot hole  
calculating depth, 410–11  
for nailing, 968  
specifying for pipe thread, 413
- Pilot relay system, 817
- Pinions, 691, 692, 696, 703
- Pin numbers, 837
- Pins, 257, 418–19
- Pintle and welded steel chains, 736
- Pipe assemblies, 910, 913
- Pipe drafter, 20, 23
- Pipe drafting  
drawing sheets, 910, 914  
elements of, 870, 872, 891–910  
layout technique, 916, 917  
revisions, 914, 915–16
- Pipe drawings  
elements of, 872–74, 875
- Pipe fitters, 910, 913
- Pipelines, 869
- Pipe support symbols, 904
- Pipe threads, designing, 412–14
- Piping  
applications, 869–70  
ASME codes and standards, 876  
connection methods, 879–81  
defined, 869  
detail drawing, 910, 911  
drafting activities, 870, 872, 891–910  
drawing revisions, 914, 915–16  
drawing sheets, 910, 914  
drawings types, 872–74, 875  
fittings, 881–85  
flanges, 885–87  
metrics in, 909  
sizes and wall thickness, 878  
specification, 893, 894  
types of pipe, 876–78  
valves, 887–91
- Piping elevations, 909–10
- Piping isometrics, 874, 875
- Piping models  
CADD, 914–15  
miniature assemblies, 910, 914
- Piston, 681
- Pitch  
of springs, 424  
of thread, 394  
of welds, 760–61  
worm gear formula, 706
- Pitch angle, 704
- Pitch cone, 704
- Pitch diameter, 729  
bevel gear formula, 704  
spur gear formula, 697, 703  
of thread, 394  
worm gear formula, 706
- Pitch gage, 406
- Pitch line, 703  
of V-belts, 729
- Pivoted followers, 684
- Pixel density, 91
- PL. *See* Parts list (PL)
- Placed features, 107
- Plain bearings, 709
- Plain end (PE) preparation, 879
- Plain wire, 938
- Plan and profile, 1109
- Planar surfaces, 542
- Plan-do-check-act (PDCA) cycle, 1133
- Plane geometry  
defined, 219
- Plane of projection, 249
- Planned unit development, 1094–95, 1097
- Plans  
defined, 930  
piping, 892, 894
- Plan views (highway layout), 1087–88
- Plastic gears, 706–08
- Plastic part manufacturing, drawings for,  
369–70
- Plastic resin identification codes, 129
- Plastics  
major types, 122, 126–29  
manufacturing processes, 153–59  
for pipe, 877  
reusability of, 130  
section lines for, 202  
selection applications, 129–31  
as sustainable material, 130  
using, 130
- Plate, 776
- Plate cams, 684, 687
- Plated-through holes, 842–43



- Plates (steel), 962–63, 964  
 Platings, dimensioning with, 361  
 Platinum, 125  
 Plats, 1084, 1085, 1095–96, 1102. *See also*  
 Subdivision plats  
 PLM. *See* Product life cycle management  
 (PLM)  
 PLM system. *See* Product life cycle  
 management (PLM) system  
 Plot device, 98  
 Plot plan, 1091, 1092  
 drawings, 817  
 Plots, electronic, 98  
 Plots of land, 1082  
 Plotters, 114  
 Plotting, 1077  
 CADD, 98, 99–100  
 Plotting traverses, 1077–78  
 Plug, 885  
 Plug taps, 395  
 Plug valves, 887, 888  
 Plug welds, 745, 754, 755  
 Plumbing, 869  
 Plumbing drafter, 20, 23  
 Plus draft method, 370  
 Plus/minus dimensioning, 351, 353  
 Plywood, specifying in drawings, 960  
 Plywood lumber beams, 955, 959  
 PM. *See* Powder metallurgy (PM)  
 Point of beginning, for traverses, 1075,  
 1077, 1078  
 Point of curve (PC), 1087  
 Point of intersection (PI), 1088, 1091  
 Point of reverse curve (PRC), 1087  
 Point of tangency (PT), 1087  
 Points established by extension lines,  
 324, 338  
 Point-to-point dimensioning. *See* Chain  
 dimensioning  
 Point-to-point interconnecting wiring  
 diagrams. *See* Wiring diagram  
 Polar coordinate dimensioning, 343  
 Polar coordinate dimensions, 197  
 Polar orientation  
 locating multiple tabs in, 344  
 Poles, true versus magnetic, 1074–75  
 Polyacrylic rubber (ABR), 129  
 Polyallomers, 127  
 Polyamide, 127  
 Polyarylate, 127  
 Polybutadiene, 129  
 Polycarbonates, 128  
 Polyester film, 52–53  
 Polyetheretherketone (PEEK), 128  
 Polyethylene (PE) pipe, 877  
 Polyethylene, 128  
 Polygonal modeling, 102  
 Polygons  
 dimensioning, 336  
 guide to constructing, 230–33  
 regular, 221–22  
 Polyhedrons, 222  
 Polyimides, 128  
 Polyisoprene, 129  
 Polymerization, 126  
 Polymers. *See also* Plastics  
 major types, 122, 126–29  
 Polyphenylene oxide (PPO), 128  
 Polyphenylene sulfide (PPS), 128  
 Polypropylene, 128  
 Polystyrene, 128  
 Polysulfide rubber, 129  
 Polysulfones, 128  
 Polyurethane, 129  
 Polyvinyl chloride (PVC), 128  
 for pipe, 877  
 Pop safety valve, 890  
 Porcelain  
 section lines for, 202  
 Portfolios, 589  
 Positional tolerance zone, 514, 522  
 Positional tolerancing, 512, 513, 522, 530  
 based on the surface of a hole, 513, 514  
 of coaxial features, 519–21, 522  
 of fasteners, 523–26, 527  
 at least material condition, 515  
 locating symmetrical features, 531, 532  
 at maximum material condition, 513  
 at regardless of feature size, 514–15  
 Positive drive belts, 729, 730  
 Positive work habits, 113  
 Postmortem review, 1147  
 Postprocessors, 87, 164  
 Postproduction review, 1147  
 Posture, 113  
 Poured concrete construction, 936–45,  
 946–49, 950  
 Poured-in-place concrete, 938–39  
 Powder forging (PF), 140  
 Powder metallurgy (PM), 139–40  
 Power hacksaw, 144  
 Power substation design drawings,  
 814–19, 820  
 Power-supply plan, 821, 823  
 PP. *See* Picture plane (PP)  
 PPO. *See* Polyphenylene oxide (PPO)  
 PPS. *See* Polyphenylene sulfide (PPS)  
 PRC. *See* Point of reverse curve (PRC)  
 Precast concrete  
 beam drawing, 946  
 manufacturing methods, 939–41  
 panel drawings, 943, 945, 948  
 slab drawing, 947  
 Precedence of lines in multiviews, 266  
 Precious metals, 125  
 Precision chains, 734–36  
 double pitch roller chain, 735  
 inverted tooth silent chain, 736  
 offset sidebar roller chain, 736  
 roller chain, 734–35  
 Precision running fits, 357  
 Precision sheet metal. *See also* Sheet metal  
 bending, 782–87  
 CADD in drafting/designing of, 783  
 dimensioning applications, 792–95  
 drafting, 776–808  
 layout, 777–82  
 overview, 776–77  
 Predictive engineering, 163, 1152  
 Prefabricated steel structures, 961–62  
 Preparing a drawing, 40  
 Preproduction build, 1144  
 Prequalified fillet welds  
 sizes for, 752  
 Prequalified welded joints, 765  
 Press break, 786  
 Pressure angle spur gears, 696, 697  
 Pressure regulating valve, 891  
 Prestressed concrete structures, 940–41, 942  
 Primary auxiliary views, 299  
 Primary datum, 479, 481  
 Prime circles in cam profiles, 688–89  
 Prime meridian, 1073  
 Principal plane, 780  
 Print, 13  
 Printed circuit board (PCB), 810, 838, 840.  
*See also* Printed circuits  
 Printed circuit-board artwork, 841  
 Printed circuits, 838, 840–46  
 design and layout, 838–41  
 preparation, 844–45  
 scale, 842  
 Prisms  
 basic features, 222  
 Problem-solving process, 39  
 Process, content *versus*, 118  
 Process and instrumentation diagram  
 (P&ID), 870, 872  
 Process flow diagram (PFD), 870, 871  
 Process notes, 604, 605, 622  
 Process piping, 869  
 equipment symbols, 903  
 Process vessels, 874  
 ProConcrete, 73  
 Product bill of materials, 1142  
 Product catalog, 622  
 Product data management (PDM), 79  
 Product description/business case, 1135  
 Product development sequence, 122  
 Production sample inspection, 1144, 1147  
 Product life cycle, 131, 1147  
 Product life cycle management (PLM)  
 system, 1134  
 for CADD, 73, 79  
 Product release level, 1144  
 Products, precision sheet metal, 777  
 Pro/ENGINEER, 74  
 Profile form and orientation tolerance  
 zone, 543  
 Profile of a surface tolerance. *See* Surface  
 profiles  
 Profiles, 1087, 1109  
 through grading plans, 1095, 1099  
 highway layout, 1088–91  
 for map, 1088  
 steps in creating, 1088–89, 1109–10  
 Profile tolerance, 532–44  
 Progressive dies, 376  
 Projected areas  
 math application for, 307  
 Projected tolerance zone, 526–28, 529  
 Projection, 563  
 Projection, multiview  
 CADD tools and options, 270–71  
 first-angle, 251, 254  
 orthographic, 249  
 plane of, 249  
 third-angle, 251  
 Project leader, 1135  
 Project outlines, 219  
 Project plan, 1137

Project portfolio, 1135  
 Project portfolio management, 1135  
 Project termination, 1137  
 ProjectWise, 73  
 Property descriptions, 1082–84  
 Property identification standards, 1103  
 Property line layout, 1103–07  
 Propionate, 127  
 Proportional dividers, 43  
 Proportions, in sketching, 180  
 Proprietary product specification, 981  
 Prototypes, 620  
 Prototypes/prototyping, 80–84  
   conventional machining, 84  
   digital prototyping, 81  
   overview, 80–81  
   rapid injection molding, 82, 83  
   rapid prototyping, 81–82  
   subtractive rapid prototyping, 82, 83  
 Protractors, plotting traverses with, 1077–78  
 Provisional patent applications, 32  
 PT. *See* Point of tangency (PT)  
 Public-land system, 1082  
 Pulleys, 692, 728  
 Punch ID (PID), 796, 797  
 Punching, 138  
   process, 341  
 Punch press, 138  
 Purchase parts, 1141. *See also* Standard parts  
   defining, 598  
   describing, 612–14  
   gears as, 692  
 Purchasing departments, 596  
 Purlins, 947, 962  
 PVC. *See* Polyvinyl chloride (PVC)  
 Pyramid  
   developing, 1052  
   pattern development of a truncated, 1052  
 Pyramid prisms, 222, 223  
 Pythagorean theorem, 868–69, 919

## Q

QFD. *See* Quality Function Deployment (QFD)  
 Quadrilaterals, 221  
 Qualification requirements, 25  
 Quality control  
   in CIM systems, 163  
   conventional systems, 165–66  
   ISO 9000 standards, 378–79  
   statistical process control, 165–66, 169  
 Quality control charts, 121, 165, 166  
 Quality function deployment (QFD), 1139–40  
 Quality improvement, 165–66, 169, 1132  
 Quarters of township sections, 1083

## R

Rack and pinion, 696, 703, 704  
 Radial loads, 709  
 Radial survey, 1107  
 Radiant heating and cooling systems, 1018–19  
 Radiation, 1107

Radius (R), 1087  
   of a circle, 223  
   of curves in civil drafting, 1087  
   defined, 322  
   dimensioning, 322, 325  
   for turning in driveways, 1102, 1103  
 Radon, 1020  
 Raised face (RF) flanges, 887  
 Random controlled decking, 960  
 Ranges, township location by, 1083  
 Rapid injection molding, 82, 83  
 Rapid prototyping (RP), 3  
   as manufacturing process, 160  
   overview of tools for, 81–82  
   subtractive, 82, 83  
 Ratios (gear and drive), 703, 706  
 RE. *See* Reverse engineering (RE)  
 Reaction injection molding, 157  
 Reamed holes, 147  
 Reamer, 147  
 Rear chainman, 1079  
 Rebar  
   ASTM standards, 938  
   bend diagrams, 943, 948  
   defined, 937  
   specifying in drawings, 943–44, 975  
 Rebar schedules, 972, 975  
 Rectangle, drawing, 232–33  
 Rectangular, developing, 1046, 1047  
 Rectangular coordinate dimensioning, 197, 326–27, 343  
   sheet metal part, 778–79, 780  
 Rectangular patterns, 108  
 Rectangular system, 1082, 1083  
 Recycle symbol, 168  
 Recycling  
   in construction industry, 970–71  
   plastics, 129  
 Redline, 624  
 Redraws, 620  
 Reducers (pipe), 881, 883, 885  
 Reducing elbow, 881, 883  
 Reducing flanges, 886  
 Reducing laterals, 883  
 Reducing tee, 881, 883  
 Reference arrow method, 200–201, 298–99, 455  
   for removed views, 261  
 Reference designations, 828–29  
*Reference Designations for Electrical and Electronic Parts and Equipment*, 811  
 Reference dimension, 331, 332  
   defined, 322  
   symbols, 325  
 Reference features, 108  
 Reference lines, defined, 250  
   in welding symbols, 749, 750, 755, 757–59  
 Refinement of size, 553  
 Reflected ceiling plan, 824  
 Refractories, 122, 202  
 Refrigeration, 1017  
 drafter, 18  
 Regardless of feature size (RFS), 493, 494, 495, 514–15, 525  
 Regardless of material boundary (RMB), 493, 494, 499

Registration marks, 793, 795  
 Regular isometric drawing, 568  
 Regular polygons, 221–22, 230–33, 231  
 Regular polyhedrons, 222  
 Regular right cylinder, developing, 1048  
 Regular solids, 222  
 Regulating valves, 888–89  
 Regulatory approval, 1144  
 Reinforced concrete, 937  
 Reinforced concrete block construction, 945–47, 950–952, 953  
 Reinforced thermoset plastics (RTP), 128, 158  
 Reinforcing cords in V-belts, 729  
 Related part method, 261–62  
 Related views, 266  
 Relations, 105  
 Relay types, 817  
 Release documentation, 1144  
 Relief valves, 890, 891  
 Removed sections, 454–55  
 Removed views, 260–61  
 Repetitive features  
   location dimensioning, 343–44  
 Repetitive movement injury, 112  
 Repetitive strain injuries, 112  
 Reproduction methods, manual drafting, 43  
 Reprogrammable robotics, 163  
 Research  
   advanced, 1135–36  
   existing product, 1136–37  
 Research and development (R&D), 122, 604  
 Research techniques, 39–40  
 Residential electrical plans, 819–20, 821–23  
 Resin transfer molding, 158, 159  
 Resistors, 830, 832, 835  
 Retaining rings, 419  
 Return-air (RA) register, 1017  
 Reusability of CADD, 33–34  
 Reusability of plastics, 130  
 Reusing drawing content, in CADD, 96–97  
 REVCLLOUD command, 916, 985, 1041  
 Reverse engineering (RE), 74–75, 915  
 Reverse isometric drawing, 568  
 Revision clouds, 1038–39  
   piping drawings, 915–16  
   in structural drafting, 984–85  
 Revision history block, 60  
 Revision letter, 618, 626  
 Revision notes, 915, 985  
 Revisions  
   piping drawings, 914, 915–16  
   structural drafting, 984–85  
 Revision status notation, 55, 56, 61  
 Revision status of sheets block, 60–61  
 Revolved section, 453–54  
 Rework, 1132  
 RFC. *See* Running and Sliding Fits (RFC)  
 RFS. *See* Regardless of feature size (RFS)  
 Ribbed floors, 938, 940  
 Right angle helical gears, 695  
 Right angles, 220  
   defined, 227  
 Right-hand thread, 394  
 Right-of-ways, 1088  
 Right prisms, 222  
   developing, 1046, 1047

- Right triangles, 221  
 constructing, 231, 232
- Rim board, 955
- Rimmed steel, 124
- Ring-type joint (RTJ) flange, 887
- Rise (cam), 684
- Rise, for highway layouts, 1091
- Rivets, 420, 421
- RMB. *See* Regardless of material boundary (RMB)
- Road clearances, 1103
- Road load capacities, 1103
- Roadway layout, 1072
- Robotics, 163
- Rock, section lines for, 202
- Rocker arms, 680
- Rockers, 680
- Rockwell hardness test, 124
- Rolled thread forms, 396, 397
- Roller bearings, 709, 710
- Roller chain, 734–35
- Roller chain drive selection, 737–41
- Roller followers, 684
- Roll form, 788, 789
- Rolling element bearings, 709–10
- Roof coverings in wildfire zones, 1103
- Roof drainage plan, 972–76, 978
- Roof drains, 976
- Roof framing plan and details, 972, 977, 989
- Roof systems (wood frame), 947, 954, 955
- Root angle, 704
- Root diameter, 697
- Root of thread, 394
- Root openings of welds, 753
- ROTATE, 448
- Rotated views, 262
- Rotational bearings, 709. *See also* Bearings
- Rotational degrees of freedom, 481, 482
- Rotational molding process, 155–56
- Rotation arrow method, 298–99
- Roughness of surfaces, 372
- Rough sketches, 174, 272, 273, 292, 315, 316. *See also* Sketching
- Round, tangent arc applications, 223
- Rounded curves  
 showing in multiviews, 264, 265
- Rounds  
 basic features, 151  
 in casting drawings, 362  
 in forging dies, 363  
 pictorial drawing techniques, 584  
 showing in multiviews, 264, 265
- RP. *See* Rapid prototyping (RP)
- RTJ flange. *See* Ring-type joint (RTJ) flange
- RTP. *See* Reinforced thermoset plastics (RTP)
- Rubber  
 basic features, 127  
 section lines for, 202  
 synthetic types, 128–29
- Rubber-band line, 204, 205
- Run, for highway layouts, 1091
- Runners, casting, 135
- Running and Sliding Fits (RFC), 356–57
- Runout  
 defined, 410  
 showing in multiviews, 264–66
- threads, 394  
 tolerancing for, 544–46
- Runs, in pipe fittings, 881
- Rural fire department access, 1102–03
- S**
- SAE. *See* Society of Automotive Engineers (SAE)
- Safety precautions, 1102–03
- Safety valves, 890
- Sand, section lines for, 202
- Sand casting, 135, 136
- Saving drawings, 101
- Saw machines, 143–44
- SBR. *See* Styrene butadiene rubber (SBR)
- Scale factor, 98
- Scalene triangle, 221
- Scales  
 architect's, 49–50, 51  
 civil engineer's, 47–49  
 defined, 46  
 in detail views, 258–59  
 drawing, 46–47  
 exaggerated in civil drafting, 1089  
 isometric 567–68  
 mechanical engineer's, 50, 51, 52  
 metric, 47, 48  
 of piping isometrics, 910  
 of printed circuit drawings, 1089  
 selecting, 990  
 shapes, 46  
 for site plans, 1100  
 for sketching, 180–81
- Schedules, 930, 1037–38
- Schedule tracking, 1144
- Schematic diagrams, 809  
 electrical drafting, 811  
 electronic, 828–36  
 springs, 426  
 substations, 814  
 threads, 400
- Schematic representations of threads, 397
- Schematic spring representations, 426
- Schematic wiring diagram  
 electrical drafting, 812
- Screwdriver  
 assembly drawing for, 622, 623, 624
- Screwdriver symbol, 830
- Screwed connections, 879, 880
- Screwed pipe fittings, 881, 882, 885
- Screw heads, 416–17
- Screw machine, 142
- Screw threads, 152, 393, 394  
 inserts, 415  
 in isometric drawings, 572  
 measuring, 406  
 standards and terminology, 393–94
- Scupper, 976
- S curves, 235–36, 236
- Sealed bearings, 709–10
- Sealing methods, 713
- Seamless forged steel fittings, 881
- Seamless pipe, 877
- Seams, 1046  
 sheet metal, 788
- Seam welds, 754, 756–57
- Search for solution multipliers, 1130
- Seats of valves, 887
- Secondary auxiliary views, 299–300, 302
- Secondary datum, 481
- Secondary originals, 63
- Second generation reproduction, 63
- Seconds, in surveying, 1073
- Sectional view identification, 440–42
- Sectional views on different sheets, locating, 455–56
- Section drawings, 1037
- Sectioning, 449–50  
 defined, 440
- Section lines, 442–44  
 in isometric drawings, 571  
 rules for, 201–3
- Sections, 1083. *See also* Building sections  
 assembly drawings in, 603, 604, 606  
 coordination with details in structural drafting, 934, 935, 974  
 cutting-plane and section lines, 201  
 defined, 440  
 in isometric drawings, 571  
 laying out, 990  
 piping, 893–96, 894, 909–10  
 of townships, 1083
- Seismograph drafter, 18
- Self-clinching fasteners, 415–16, 416
- Self-clinching nuts, 415
- Self-clinching spacers and standoffs, 415
- Self-clinching studs, 415–16
- Self-locking nuts, 417
- Self-locking thread, 396, 397
- Self-tapping screws, 414
- Sellers, Coleman, 11
- Semiconductor, 830
- Semimetallic gaskets, 880
- Sempictorial wiring diagram, 846, 847
- Separation walls, 953
- Serdynski, David P., 1135
- Service mark, 32
- Servo systems, 163
- Setbacks, 1105
- Set screws, 409, 410, 692
- Sewer lines, 1089
- Shading, 1118
- Shading analysis, 988
- Shading techniques, 583–84
- Shaft fits, 352, 711
- Shaft shoulder and housing shoulder  
 dimension, 712–13
- Shale  
 for pipe, 878
- Shape descriptions, 250
- Shapers, 145
- Sharp-V thread forms, 396
- Shear forces, defined, 930
- Sheaves, 727, 728
- Sheet layout planning, 599
- Sheet metal. *See also* Precision sheet metal  
 defined, 776  
 flanges, 787–88  
 hems, 788  
 material application in drafting of, 791–92  
 model, 779–80, 781, 789–90  
 parts, 777  
 products, 777

- roll form, 788, 789
- seams, 788
- Sheet metal blanks, 1064
- Sheet metal drafting, 1045
- Sheet metal pattern design, 1061
- Sheet metal punch, 796–97
- Sheet sizes
  - for manual drafting, 53–54, 55–56
  - setting up in CADD, 275
  - for site plans, 1100
  - for structural drafting, 998
- Shielded metal arc welding, 747
- Shields, for ball bearings, 709
- Shop drawings, 966, 1028
- Short break line
  - on metal shape, 452
  - on wood shape, 452
- Shoulders
  - of leader lines, 324
  - of shafts and housings, 712–13
- Shrinkage allowance, 362
- Shrink fits, 357. *See also* Interference fit
- Siemens Corporation, 75
- Silicones, 129
- Silk screen artwork, 843–44
- Silver, 125
- Similarity of geometric shapes, 998
- Simple harmonic motion, 684–85
- Simplified representation of thread, 397–98, 398–400
- Simulated datum axis, 488, 489
- Simulated datums, 478, 479
- Simulation, 850
- Single- and double-line HVAC plans, 1031–32
- Single composite pattern, 516
- Single-lap seam, 788, 1046
- Single-layer boards, 842
- Single lead worms, 705
- Single-line drawing, 895, 899
- Single-row ball bearings, 709
- Single span straight beams, 953, 957
- Single-stroke Gothic lettering, 207
- Sintering, 139, 158
- Site analysis plan, 1094, 1096
- Site plan, 1091, 1092, 1093, 1094
  - CADD applications, 1113–17
  - checklist, 1107
  - contour line placement, 1106–07
  - designing, 1101–03
  - electric substations, 817
  - elements of, 1092–93, 1094, 1095
  - layout, 1100–01, 1102, 1104–06, 1107
  - metrics in, 1100
  - planned unit development, 1094–95, 1097
  - profiles, 1109–10
  - site analysis plan, 1094, 1096
  - topography, 1092, 1093
- Site profiles, 1109–10, 1111
- Sites, 1082
- SI units, 327
- Six Sigma, 377, 1133–34
- Size description, 267
- Size dimensions, 320
- Size features, 321
- Size, of electronic symbols, 830, 831, 838, 840
- Sketched features, in solid modeling, 107
- Sketching. *See also* Engineering sketches
  - arcs, 179–80
  - block technique for, 181–83, 182, 183
  - CADD, 187–91
  - circular lines, 176–79, 177, 178
  - electronic schematics, 832, 834
  - ellipses, 180, 181
  - irregular shapes, 182, 183
  - measurement lines in, 180–81, 181
  - multiview layouts, 183–84, 267, 272–75
  - overview, 174–75
  - in planning process, 218
  - proportions and scales for, 180–81
  - quality of, 175
  - straight lines, 175–76
  - tools and materials, 175
- Sketch tools (CADD), 187–91
- Skystream 3.7, 825–26
- SLA. *See* Stereolithography (SLA)
- Slabs (concrete)
  - defined, 936
  - specifying in drawings, 944, 972, 976
- Slack side idlers, 730
- Slate, section lines for, 202
- Sleeve bearings, 709
- Slider cranks, 681
- Sliding fits, 357
- Slip-on pipe flanges, 885, 886
- Slope
  - dimensioning symbol, 325
  - in site design, 1101
- Slots, 525, 532
  - dimensioning, 340–41
- Slotted features, locating, 521–22, 524
- Slot welds, 754, 755
- Sludge, 889
- Small bore piping, 895
- Small circles, 176, 197
- Smart HVAC systems, 1021
- SmartMarine 3-D, 74
- SmartSketch, 74
- SMD. *See* Surface-mounted devices (SMD)
- Smithing, 138
- Smoothness of drafting media, 50
- Society of Automotive Engineers (SAE), 123, 692
  - steel numbering applications, 124, 132
- Society of the Plastics Industry, Inc., 129
- Socket-welded connection, 879
- Socketlet, 884
- Soft copy, 98
- Soft gaskets, 880
- Soft metric conversions, 908
- Software, 10
  - CADD, 71–75
  - piracy, 31
- Solar heating integrated with radiant system, 1019
- Solar tracker, 1151
- Solar tracking equipment, 116
- Solder, 746, 880
- Soldered connection, 880
- Soldering, 746
- Solder mask, 842, 844
- Solder paste, 845
- Solder resist mask, 842, 844
- SolidEdge, 75
- Solid Enginieria Ltd, 1151
- Solid height of springs, 424
- Solid length (springs), 424
- Solid models. *See also* Parametric solid modeling
  - dimensioning and tolerancing, 360
  - multiview drawings from, 270
  - overview, 78–79
  - as pictorial models, 563, 565
  - simulating materials in, 166
  - techniques for, 104–9
- Solid object 3-D printing, 160, 161
- Solid phase forming process, 156
- SolidWorks, 74, 110
- Solvent welding pipe connections, 881
- Sound insulation, section lines for, 202
- Sound liner, 1031
- Source reduction, 1021
- Southwest Windpower, 825
- SP. *See* Station point (SP)
- Spacers, self-clinching, 415
- Spaces, dividing equally, 230
- Spacing, of letters, 209, 210
- Span, between floor supports, 939
- SPC. *See* Statistical process control (SPC)
- Specific area flatness, 505
- Specifications, 351
  - defined, 986
  - lumber, 955, 960
  - welding, 765
- Specific notes, 349
- Specific tolerance dimensions, 353
- Specified dimension, 351
  - defined, 322
- Specified inch tolerance, 352–53
- Specified metric tolerance, 353–54
- Specs (piping), 893, 894
- Spheres, 223, 572, 573
- Spherical diameter
  - dimensioning, 325
- Spherical features, position tolerancing of, 523, 526
- Spherical radius
  - dimensioning, 325
- Spherical roller bearings, 710
- Spiral gears, 695
- Spiral torsion spring, 424
- Splines, 102, 152, 692–93, 785
- Spool drawings, 874, 875, 910, 913
- Spotfaces, 148, 149, 150
  - dimensioning, 325, 340
- Spot welding, 754, 756
- Spring data, 426
- Spring index, 422
- Springs
  - characteristics, 423
  - coned disk, 425
  - constant force, 426
  - detailed representation, 426–27
  - flat, 424
  - garter, 426
  - mechanical, 421
  - schematic representations, 426, 428
  - specifications, 426
  - terminology, 423–24
  - torsion, 424
  - volute, 425
  - wave, 424–25

- Sprockets, 734, 735  
 CADD applications, 735
- Spur gears, 694, 696, 697, 698, 699, 702, 703–04
- Square features and symbol, dimensioning of, 334
- Square groove welds, 753
- Square-head bolts, 417
- Squares, drawing, 232–33
- Square shape dimensioning symbol, 325
- Square thread form, 396
- Square to round, 1052–53
- S-shaped curve design, 2
- STA. *See* Stations (STA)
- Stacking, 331
- Stadia technique, 1079, 1080
- Stagger adjacent dimensions, 334
- Stainless steels, 123
- Stamping press, 791
- Stampings, 138–39, 167–68
- Standard ANSI fits  
 description of, 356–57  
 designation of, 356  
 establishing dimensions for, 357, 358
- Standard ANSI/ISO Metric Limits and Fits, 357–59
- Standard General Requirements for Electronic Equipment*, 836
- Standard line-fitting symbols, 904
- Standard parts, 598. *See also* Purchase parts
- Standards. *See also* ANSI standards  
 CADD, 111–12  
 drafting, 29–30  
 ISO 9000, 378–79  
 screw threads, 393–94
- Standoffs, 415
- Static load spring application, 425
- Static pressure (SP) classifications, 1028–29
- Statics, 679
- Static sealing of bearings, 713
- Station point (SP), 578, 1075
- Stations (STA), 1079, 1107  
 finding distance and elevation from, 1079–82, 1107–08
- Statistical process control (SPC), 165–66, 169, 354
- Statistical tolerancing, 325, 354, 355
- Steam tracing, 877
- Steel  
 building structures with, 960–66  
 in green construction, 969–71  
 for pipe, 877  
 properties and types, 123–24  
 reinforcing bars, 937, 938  
 section lines for, 202  
 springs, 421
- Steel alloys, 123
- Steel castings, 123
- Steel deck systems, 938, 939
- Steel-framed structures, 962
- Steel pipe, 964
- Steel stud construction, 960–61
- Steel tubing, 877
- Stereolithography (SLA), 81, 160
- Stick electrode welding, 747
- Stipple shading, 584
- Stitch lines, 204
- Stock size  
 defined, 322
- Storage  
 CADD devices, 101  
 defined, 71  
 original drawings, 63–64
- Storyboarding, 86
- Straight angles, 220
- Straight laterals, 883
- Straight line segment, 219
- Straight line motion, 685, 686
- Straight lines, 175–76
- Straight line shading, 584
- Straightness tolerance, 504
- Straight taps, 1037
- Straight tee, 881, 883
- Street elbow, 885
- Stress analysis (gear), 708
- Stressed skin panels, 955, 960
- Stretching exercises, 113–14
- Stretch-out line, 1046
- Stroke, 681
- Structural drafters, 20, 23
- Structural drafting. *See also* Construction methods  
 basic drawing layout steps, 988–90  
 commercial construction specifications, 986–88  
 complete drawing sets, 972–79  
 for concrete block construction, 945–47, 950–952, 953  
 for concrete construction, 936–45, 945–47, 948  
 construction specifications, 986  
 engineered wood products, 953, 955, 959–60  
 from engineering calculations, 928–29  
 heavy timber construction, 948, 950, 955  
 laminated beam construction, 950, 953, 957–59  
 lettering on, 933  
 line work on, 930–32  
 revisions, 984–85  
 standards, 930  
 steel structures, 960–66  
 wood construction overview, 947–60, 953–56  
 working drawing organization, 933–36
- Structural engineering  
 defined, 930
- Structural steels, 962–65
- Structural Steel Shapes*, 962
- Structural tees, 963
- Stub-end flanges, 885, 886
- Studs, self-clinching, 415–16
- Styrene butadiene rubber (SBR), 129
- Subassemblies, 835  
 defined, 106  
 welded, 749  
 working drawings for, 606–07
- Subdivision plans, 1084, 1095–98
- Subdivision plats  
 describing, 1084  
 examples, 1083, 1084
- Substation, 814  
 design drawings, 814–19, 820
- Subtractive rapid prototyping, 82, 83
- Supervisory control relays, 817
- Supplementary welding symbols, 750, 751
- Supply chain integration, 1152
- Supports (piping), 894, 895, 897.  
*See also* Hangers
- Surface condition, bend allowance and, 782
- Surface finishes, 371–72, 713  
 characteristics of, 372–73  
 defined, 153, 370–71  
 of shafts and housings, 713  
 surface roughness, 372  
 surface waviness, 372
- Surface geometric control, 494, 495
- Surface models  
 overview, 77–78  
 techniques for, 102–3
- Surface-mounted devices (SMD), 845–46
- Surface profiles, 536–42. *See also* Tolerances
- Surface roughness, 372
- Surfaces, creating, 102–3
- Surface straightness tolerance, 504
- Surface texture, 370. *See also* Surface finishes
- Surface waviness, 372
- Survey information, 1072
- Surveying  
 bearings, 1074  
 direction concepts, 1073–75  
 distance and elevation, 1078–82  
 grid azimuth, 1075  
 magnetic azimuth, 1074–75  
 plotting traverses, 1077–78  
 traverse types, 1075–77  
 true azimuth, 1073–74
- Surveyors' map, 1100, 1102
- Sustainability, 1021  
 defined, 115, 131
- Sustainable buildings, defined, 969
- Sustainable CAD, 116–17
- Sustainable design, 115–17  
 analysis for, 992  
 opportunity, 992  
 in practice, 992
- Sustainable energy, use, 992
- Sustainable material, use, 992–93
- Sustainable water, use, 992
- Swaging, 138, 881
- Sweepolet, 884
- Swing check valves, 890
- Switch symbols, 820, 822
- Symbol dialog box (AutoCAD), 548, 549
- Symbol libraries  
 creating and using, 33–34  
 for fasteners, 421  
 piping, 900, 901–2, 901–7  
 welding symbols in, 766
- Symbols  
 bearings, 710  
 break lines, 203  
 CADD, 96–97  
 datum features, 478, 480, 481, 488, 490  
 datum target, 483–87  
 dimensioning, 325  
 electric power systems, 815–16  
 electronics, 829–32  
 elevation, 972, 977  
 feature control frame, 487–88

first-angle projection, 254  
 geometric tolerancing, 477, 501, 502  
 integrated circuit, 837  
 linkages, 679–80  
 material condition, 492, 493, 496  
 metric fits, 358  
 nondestructive tests, 763–64  
 piping, 900, 901–2, 901–7  
 recycle symbol, 168  
 sizes, 830, 831, 838, 840  
 symmetry, 531  
 third-angle projection, 254  
 welding, 745, 749–51, 752, 766  
*Symbols for Mechanical And Acoustical Elements As Used In Schematic diagrams*, 811  
 Symbols library  
   CADD, 97  
 Symmetrical features  
   position tolerancing, 531  
 Symmetrical objects, dimensioning of, 334  
 Symmetrical shape  
   dimensioning, 325  
 Symmetry geometric tolerance, 530–32  
 Symmetry symbol, 197, 198  
 Synerject LLC, 89  
 Synopsys, Inc., 850  
 Synthetic rubbers, 128–29  
 Systems, defined, 983  
 Systems approach to engineering design, 1130–31

**T**

T&C pipe. *See* Threaded and coupled (T&C) pipe  
 Table movements (milling machine), 143  
 Tables, 780, 782  
 Tabular, 612  
 Tabular dimensioning, 327  
 Tags, 901, 1028  
 Tails in welding symbols, 749, 750  
 Tangent arcs  
   drawing, 233  
 Tangent circles, distance between, 629  
 Tangents  
   construction, 233–36  
   defined, 179, 224  
   design and drafting applications, 233–36  
 Tap drill (thread), 394  
 Tapered roller bearings, 710  
 Taper pins, 418–19  
 Taper pipe threads, 413–14  
 Taper taps, 395, 411  
 Taps (thread), 394, 395  
 Taps, 153  
   defined, 1037  
 Tap set, 395  
 Tax incentives for wind power generators, 826  
 Team, 1132  
 Technical drafting/drawing. *See* Engineering drawing  
 Technical illustration, 88  
   pictorial drawings versus, 565, 566  
 Technical illustrators, 20, 22, 23–24, 24, 589  
 Tektronix parts library, 33–34

Telerobotics, 90  
 Tempering, 124  
 Templates, 44–45  
   creating and using, 99, 100–101  
   defined, 99  
   drawings, 99, 100–101  
   undimensioned drawing, 792  
 Tensile strength, 122  
 Tensile stress, 938, 939  
 Terminal, 842  
 Terminal pads, 841, 843  
 Terminal units, 1018  
 Terrain model, 1115  
 Tertiary datum, 481  
 Text. *See also* Lettering  
   adding with CADD, 210–11  
   for dimensioning, 324  
   locating, 211  
   model, 212  
   styles, 210, 211  
 Text editor, 210  
*The Architect's Handbook of Professional Practice*, 935  
 Theodolites, 1079, 1081  
 Thermal insulation, section lines for, 202  
 Thermofforming of plastic, 156  
 Thermoplastic elastomers (TPE), 129  
 Thermoplastic polyesters, 128  
 Thermoplastic rubbers (TPR), 128  
 Thermoplastics  
   common types, 127–28  
   defined, 122  
   manufacturing processes, 153–57  
   for pipe, 877  
 Thermoset plastics  
   applications, 128  
   common types, 128  
   defined, 122  
   manufacturing processes, 157–58  
 Thermostat, 1016, 1021  
 Thickness, bend allowance and, 782  
 Thin materials, section drawings of, 202  
 Third-angle projection, 251  
   elements of, 252–53, 254  
 THL. *See* True-height lines (THL)  
 Thorson, Troy, 1135  
 Thread design guidelines, 410–14  
   external threads, designing, 411–12  
   pipe threads, designing, 412–14  
   threaded holes, designing, 410–11  
 Threaded and coupled (T&C) pipe, 879  
 Threaded fasteners, 408–09  
   bolts and nuts, 408, 409  
   cap screws, 409, 410  
   machine screws, 408, 409  
   set screws, 409, 410  
 Threaded holes, designing, 410–11  
 Threaded rods, 153  
 Thread form, 394  
 Thread inserts, 414, 415  
 Thread notes, 403–05, 406  
   Acme thread, 404  
   CADD, 406, 408  
   in drawings, 404–05, 406  
   metric threads, 404  
   Unified and American National threads, 403

Threads, 394  
   detailed drawings, 400–03  
   drawing, 152–53  
   forms of, 395–97  
   in isometric drawings, 572  
   measuring, 406  
   metric, 404  
   position tolerancing, 523  
   representations, 397–400  
   schematic diagrams, 400  
   simplified representation of, 398–400  
   standards and terminology, 393–94  
   tools for cutting, 395  
   types, 152–53  
   Unified and American National threads, 403  
   worm gear formula, 706  
 Thread series, 394  
 Threads per inch, 394  
 Thredolet, 884  
 3-D digitizers, 915  
 Three-dimensional illustration capabilities, 588–89  
 3-D model, 13, 14  
 3-D printer, 3  
 3-D printing, 81–82, 160, 161  
 Three-dimensional solid models, 78–79  
   multiview drawings from, 270  
 Three-dimensional surface models, 77–78  
 Three-dimensional visualization tools, 563, 565  
 Three-dimensional wireframe models, 76, 77  
 3ds Max, 73  
 Three-hinged arch beams, 953, 957  
 Three-point perspective, 578, 580–82  
 Through-the-window VR. *See* Passive VR  
 Thrust bearings, 709  
 Thrust loads, 709  
 Ties, 938  
 Tight side idlers, 730  
 TIG welding. *See* Tungsten inert gas welding (TIG) welding  
 Tilt-up precast concrete, 941–42  
 Timing, 682  
 Titanium, 125, 202  
 Title blocks, 57–59  
   general notes in, 350  
 Tobacco smoke, 1020  
 Tolerances. *See also* Geometric tolerance  
   for bearings, 710–11  
   buildup, 331  
   defined, 323, 351  
   and drawing specifications, 696  
   of gear teeth, 696–98  
   for metric threads, 404  
   undimensioned drawings, 793  
   welding, 762  
 Tolerance zones, misinterpreting, 553  
 Tolerancing applications, 351  
   allowance, 355  
   CADD applications, 360–61  
   clearance fits, 355  
   extreme form variation, 356  
   fits, types of, 356–59  
   inch tolerances, specified and unspecified, 352–53  
   interference fits, 355–56

- Tolerancing applications (*continued*)  
 maximum and least material conditions, 355  
 metric tolerances, specified and unspecified, 353–54  
 single limits, 352  
 statistical tolerancing, 354, 355
- Tongue-and-groove decking, 960  
 Tongue-and-groove facings, 887  
 Tool-and-die design drafter, 22  
 Tool design, 160, 161, 162, 373  
 designer's tools, 377–78  
 process, 374–77  
 Tool offset, 164  
 Tool path displays, 382  
 Tool process, 374–77  
 Tool runout, 411  
 Top-down assembly, 108  
 Topographical drafter, 16  
 Topography, on site plans, 1092, 1093  
 Torsion, 424, 765  
 Torsion bar spring, 424  
 Total indicator reading (TIR). *See* Full indicator movement (FIM)  
 Total quality management (TQM), 1134  
 Total runout, 544–45  
 Total station theodolites, 1081  
 Townships, 1083  
 Toyota production system (TPS), 1132  
 TPE. *See* Thermoplastic elastomers (TPE)  
 TPR. *See* Thermoplastic rubbers (TPR)  
 TPS. *See* Toyota production system (TPS)  
 TQM. *See* Total quality management (TQM)  
 Track drafting machine, 13, 46  
 Trademarks, 32–33  
 Trails, in exploded assemblies, 575  
 Trammel method, 178, 178–79  
 Transfer molding, 157  
 Transferring, triangles, 229  
 Transistors, 832  
 Transition fits, 358  
 Transition piece, 786  
 Transition piece development, 1054  
 Transition piece pattern development, drawing, 1052–55  
 Transit lines, 1087  
 Transits, 1079, 1081  
 Transit stations, 1107  
 Transit theodolites, 1081  
 Translational degrees of freedom, 481, 482  
 Transmission, electricity, 814  
 Transmitter symbols, 202  
 Transparency of drafting media, 51  
 Transportation piping, 869  
 Transportation waste, 1132, 1133  
 Travel of angled pipe, finding, 919  
 Traverses, 1075–77  
 Traverse stations, 1075  
 Triangles, 43–44  
 basic features, 220–21  
 guide to constructing, 231  
 transferring, 229  
 Triangulation, 231, 1053  
 curve-to-curve, 1055  
 TRIM command, 401  
 Trimetric projection, 563, 574–75  
 True azimuth, 1073–74  
 True geometry view, defined, 249  
 True-height lines (THL), 579  
 True poles, magnetic poles versus, 1074–75  
 True position, 512  
 True Y fittings, 881  
 Truncated cylinder pattern development, 1048–49  
 Truncated prism pattern development, 1047–48  
 Truncated pyramid, pattern development of a, 1052  
 Truncated solids defined, 222  
 Trunk lines, 812  
 Truss roof system, 947, 954  
 T-slot, 153  
 Tubing  
 copper, 877  
 steel, 877  
 structural, 963–64  
 Tudor arch beams, 953, 957  
 Tungsten, 123, 125  
 Tungsten carbide, 125  
 Tungsten inert gas welding (TIG) welding, 747  
 TurboCAD, 74  
 Turnarounds, 1104  
 Turning aprons, 1102  
 Turning points, 1079–80  
 Turnouts, 1103  
 Turret lathes, 141  
 Two-dimensional drawings  
 overview, 71, 76, 77  
 creating from parametric solid models, 270  
 Two-pipe hot-water system, 1018  
 Two-point perspective, 578, 580  
 Two single-segment feature control frames, 517, 519  
 Two-view drawings, 256  
 Typical cross sections, 976, 978
- ## U
- U.S. Green Building Council (USGBC), 969, 971, 992, 1019  
 U groove welds, 754  
 UL. *See* Underwriters Laboratories (UL)  
 Ultrasonic machining, 145  
 Unconstrained line, 204, 205  
 Undercuts, 153  
 Underwriters Laboratories (UL), 1144  
*Undimensioned Drawings*, 780, 792, 842  
 Undimensioned drawings, 792, 1061  
 ASME standard, 780, 792  
 media used for, 793  
 tolerances, 793  
 Unequal bilateral tolerance, 351  
 Unequally disposed profile tolerance, 538, 540–41  
 Unidirectional dimensioning, 326  
 Unified and American National threads, 403  
 Unified Inch Screw Threads, 394  
 Unified Numbering System (UNS), 125–26  
 Unified Screw Threads Metric Translation, 394  
 Unified thread form, 395  
 Unified Thread Series, 393
- Uniform accelerated motion, 685–86  
 UniFormat, uniform classification system, 987–88  
 Uniform classification system, 987–88  
 Unilateral profile tolerance, 534–36, 538, 539, 540–41  
 Unilateral tolerance, 323, 351, 534  
 Unions, for screwed pipe, 882, 885  
 United States (U.S.) customary units, 327  
 United States Department of Energy National Renewable Energy Laboratory (NREL), 825  
 United States National CAD Standard (NCS), 30, 112  
 Unit flatness, 505  
 Units  
 conventional standards and practices, 327, 328–29  
 electronics, 835–36  
 in site plans, 1097  
 in surveying, 1079  
 in welding symbols, 751  
 Unit straightness, 504  
 Universal milling machines, 143  
 Universal recycle symbol, 168  
 UNS. *See* Unified Numbering System (UNS)  
 Unsaturated polyesters, 128  
 Unsectioned features, 446–47  
 Unspecified inch tolerance, 352–53  
 Unspecified metric tolerance, 353–54  
 Unspecified tolerances, 59  
 Uploading, on beams, 955  
 Upper control limits, 166, 351  
 Upset forging, 138  
 Urea formaldehyde, 128  
 User interface, 188  
 USGBC. *See* U.S. Green Building Council (USGBC)  
 Utility Scale Solar, Inc., 116  
 Utility services drawings, 1089–91
- ## V
- V28™ Lithium-Ion Sawzall, 1135  
 Vacuum bag forming, 158, 159  
 Value, 1132  
 Value chain integration, 1152  
 Value numbers, 836  
 Valve actuator symbols, 901, 902  
 Valves (piping), 887–91, 900, 901, 902  
 Vanadium alloy, 123  
 Vanishing point left (VPL), 578, 580  
 Vanishing point right (VPR), 578, 580  
 Vanishing point vertical (VPV), 578  
 Vanish thread, 394  
 Variable air volume (VAV)  
 box, 1044  
 units, 1018  
 Variable resistors, 830  
 Variable-value device, 830  
 Variation, 166  
 V-belts, 728  
 basic features, 728–29  
 common configurations, 729  
 drive design, 731–34  
 Vellum, 52

- Ventilation  
 air-to-air heat exchangers, 1020  
 sources of pollutants, 1019–20
- Verification, 850
- Vertex, defined, 222
- Vertical band saw, 144
- Vertical curve, 1091  
 point, 1091
- Vertical mills, 142
- Vertical scales, exaggerated, 1089
- Vertical uppercase Gothic, 13
- Vertices, defined, 76
- V groove welds, 753
- Vicinity map, 1094, 1097
- View enlargements  
 for auxiliary views, 297  
 CADD tools and options, 269, 271  
 in multiview drawings, 258–59
- Viewing-plane lines, 200, 200–201, 297, 298
- View selection, 254–62
- Virtual, defined, 74
- Virtual Building software, 74
- Virtual condition, 513, 528–29, 530, 531
- Virtual reality (VR)  
 applications, 89–90  
 opportunities, 93  
 passive, 90  
 tools for, 90–93
- Virtual team, 1152
- Virtual worlds, 92–93
- Viscosity, 713
- Visible lines, 195
- Visual engineering, 1152
- VOC. *See* Voice of the customer (VOC)
- Voice of the customer (VOC), 1139
- Volute spring, 425
- VPL. *See* Vanishing point left (VPL)
- VPR. *See* Vanishing point right (VPR)
- VPV. *See* Vanishing point vertical (VPV)
- VR. *See* Virtual reality (VR)
- VRML. *See* Web-enabled virtual reality modeling language (VRML)
- Vulcanization, 128, 158
- W**
- Waffle floors, 938, 940
- Waiting-time waste, 1132, 1133
- Walk-throughs, 89
- Wall details, 979, 982
- Warm air (WA), 1016–17
- Washers, drawing, 418
- Waste  
 defined, 1133  
 elimination, 1133  
 lean manufacturing and, 1133  
 Toyota production system (TPS) and, 1132
- Water, section lines for, 202
- Water jet cutting, 144–45
- Water Pik, Inc., 110–11
- Wave solder, 842
- Wave spring, 424–25. *See also* Flat wire compression springs
- Waviness of surfaces, 372
- Web-based collaboration, 79–80
- Web-browser plug-in, 92–93
- Web-enabled virtual reality modeling language (VRML), 92–93
- Web site research, 1065
- Weld-all-around symbol, 760, 761
- Welded connections, 968
- Welded pipe, 877  
 fittings, 881
- Welded wire reinforcement (WWR), 937–38
- Welding  
 advantages, 745–46  
 drawing elements for, 748–51  
 forge method, 138  
 importance of understanding, 768  
 indicating locations for, 755, 757–59  
 overview, 745  
 penetration, length, and other information, 759–62  
 pipe connection by, 879  
 processes, 746–48  
 specifications, 765  
 tests of, 762–64  
 weld design guidelines, 765  
 weld types, 751–55
- Welding fixtures, 375
- Welding jigs. *See* Welding fixtures
- Welding ring, 881, 882
- Weld length and pitch, 760–61
- Weldments, 749
- Weld-neck flanges, 885, 886
- Weldolets, 881, 884
- Weld symbols, 749–50, 751
- White cast iron, 122
- White metal  
 section lines for, 202
- Whitworth screw threads, 394
- Whitworth thread form, 396
- Whole depth, 697, 706
- Whole-systems approach to engineering design, 1130–31
- Wide-mouth taps, 1037
- Widths of bearings, 710–11, 713
- Wildfire zones, 1103  
 roof coverings in, 1103
- Windchill, 75
- Windows, in reinforced concrete walls, 952
- Wind power, electricity generation from, 825–27  
 remote installations, 826, 827  
 residential electricity generation, 825–26  
 tax incentives, 826
- Wireframe models, 76, 77
- Wire list (WL), 612
- Wire reinforcement, 937–38, 943
- Wiring diagram  
 electrical drafting, 811, 812  
 semipictorial, 846, 847
- WL. *See* Wire list (WL)
- Wood, section lines for, 202
- Wood frame construction, 947–60  
 anchoring to masonry, 947, 956  
 engineered wood products, 953, 955, 959–60  
 heavy timber, 948, 950, 955  
 laminated beam, 950, 953, 957–58  
 overview, 947  
 standard callouts, 957–60
- Wood pipe, 878
- Wood screws, 414
- Wool seals, 715
- Work features, 108
- Work habits, 113
- Working depth, spur gear formula, 697
- Working drawing, 596  
 analysis, 620–27  
 assembly drawings, 603–04, 605  
 change order (CO), 616–18, 619  
 coordination in structural drafting, 933–36  
 detail assembly, 605–06  
 detail drawings, 598–99  
 drawings, editing, 618–19  
 engineering change notice (ECN), 616–18, 619  
 engineering change order (ECO), 616–18, 619  
 engineering change redraw, 620  
 engineering change request (ECR), 615–16  
 erection assembly, 606, 609  
 general assembly, 605  
 identification numbers in, 607–08, 715–16  
 layout assembly, 604–05, 606  
 overview, 597  
 parts lists for, 608–12  
 pictorial assembly, 607, 610  
 from prototype, 620  
 purchase parts, 612–14  
 subassembly, 606–07
- Work results, 986
- Workstation, 71, 72, 113
- World Wide Web, 92–93
- Worm gears, 695, 705–06, 707  
 basic features, 695  
 designing and drawing, 706
- Wrench, 2–7, 3–7
- X**
- Xenon (CADD software), 73
- Xeriscaping, 1118
- Xerography, 62
- XLINE command, 267
- Y**
- Yellow belts, 1134
- Y turnarounds, 1104
- Z**
- Zero geometric tolerance, 512
- Zero positional tolerance, 513–14  
 at maximum material condition (MMC), 529, 531
- Zinc, section lines for, 202
- Zoned control system, 1018
- Zoning, 57
- Zuken, Inc., 850